

NOTES:
 1. UNLESS OTHERWISE SPECIFIED:
 a) RESISTANCE IS IN OHMS, $\pm 5\%$, 1/8W.
 b) CAPACITANCE IS IN μF .
 2. DIFFERENCE BETWEEN TYPES IS SHOWN IN TABLE I.

TABLE I										
TYPE	USED WITH INTERFACE	JW1	JW2	JW3	U7	U9	U11	U15	Y2	R6
796617-1	RS-232C/LOGGING	1-2	1-4	N/A	N/U	N/U	N/U	N/U	N/U	N/U
-2	MIL-STD-188C/LOGGING	2-3	1-2	N/A	N/U	N/U	N/U	N/U	N/U	N/U
-3	WJ-9073-2 COAX	1-4	N/A	1-2	N/U	LH0002	SN75140	N/U	N/U	20 $\frac{1}{4}$ W
-4	WJ-9073-2 FIBER OPTIC	1-4	N/A	2-3	SN75453P	N/U	N/U	N/U	N/U	N/U
-5	TAPE LOGGING	1-2	1-5	N/A	N/U	N/U	N/U	TCM3105	4.4336MHz	N/U
-6	WJ-9075 COAX	3-4	1-3	1-2	N/U	LH0002	SN75140	N/U	N/U	47 $\frac{1}{4}$ W

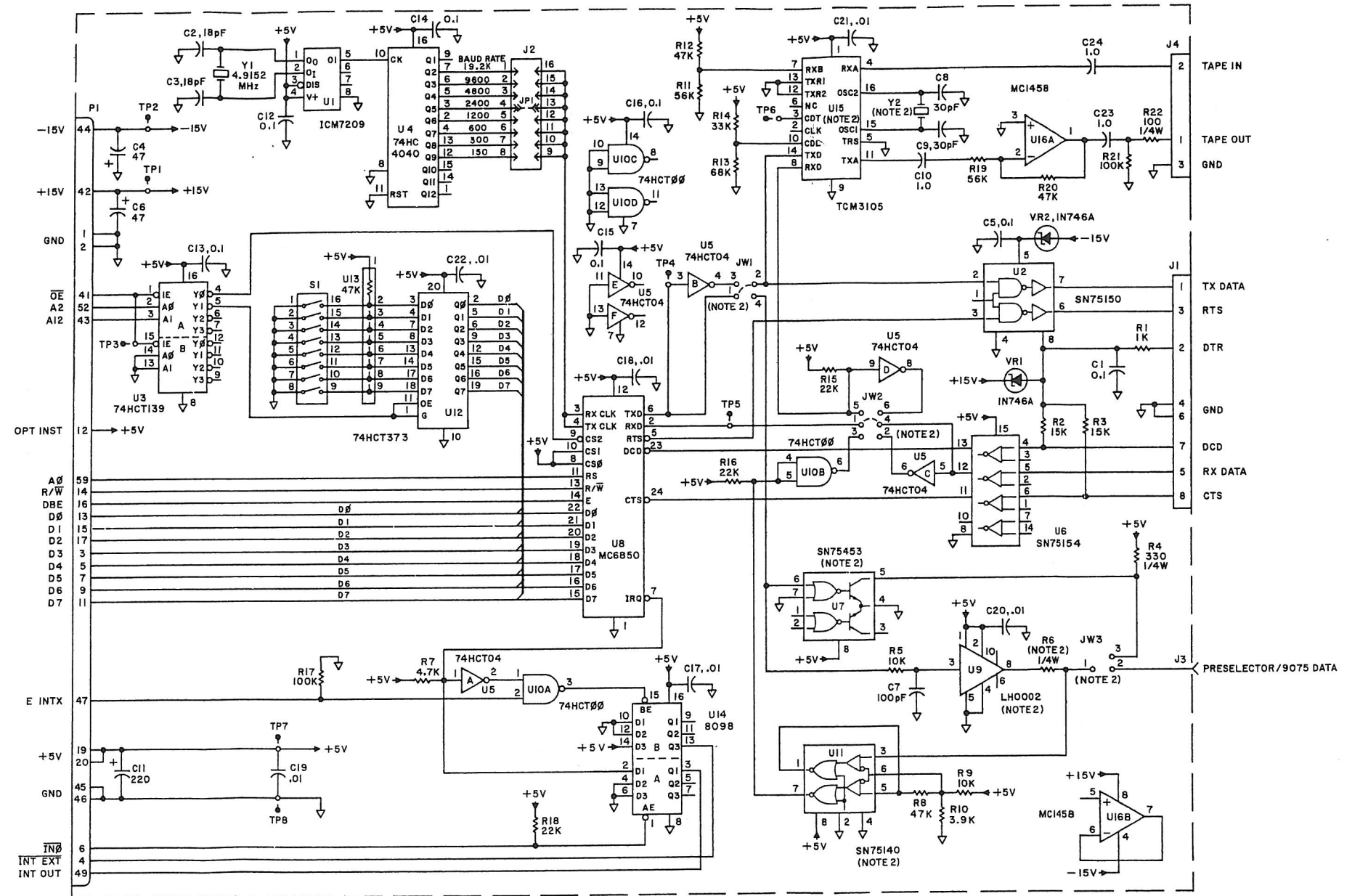

Figure R-5. Type 796617-1, Serial Interface RS-232 Schematic Diagram 580723 (C)

NOTE:
 1. TYPE 796617-1, SCHEM 580723
 USE ON (S1) SERIES RECEIVERS.

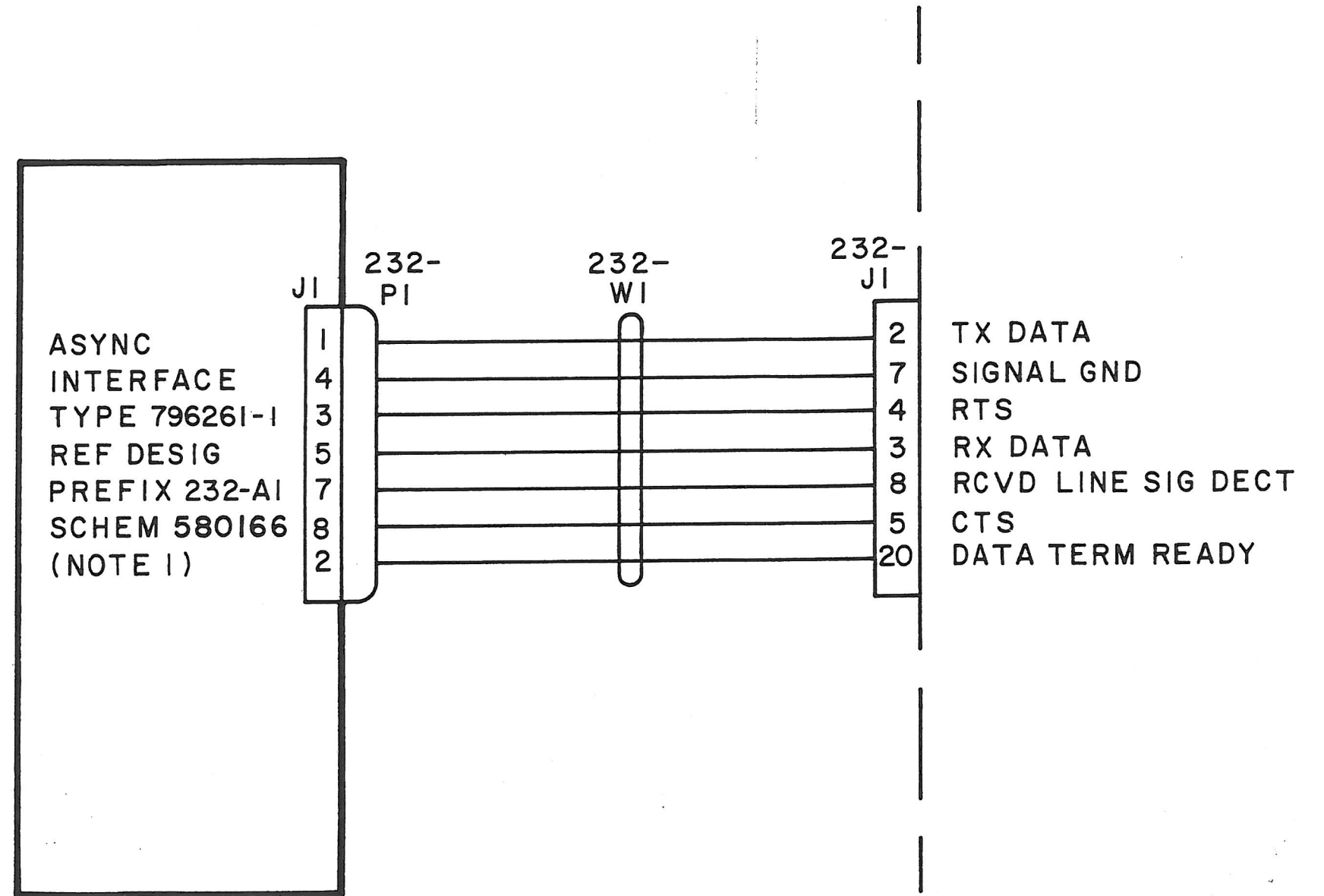

Figure R-6. Type WJ-861XB(S1) RS-232 Interface Bus Schematic Diagram 290320 (E)