

**INSTRUCTION MANUAL
FOR THE
WJ-9205 SIGNAL MONITOR**



WATKINS-JOHNSON

INSTRUCTION MANUAL
FOR THE
WJ-9205 SIGNAL MONITOR

WATKINS-JOHNSON COMPANY
700 QUINCE ORCHARD ROAD
GAITHERSBURG, MARYLAND 20878

October 1989

WARNING

This equipment utilizes voltages which are potentially dangerous and may be fatal if contacted. Exercise extreme caution when working with the equipment with any protective cover removed.

PROPRIETARY STATEMENT

This document and subject matter disclosed herein are proprietary items to which Watkins-Johnson Company retains the exclusive right of dissemination, reproduction, manufacture and sale.

This document is provided to the individual or using organization for their use alone in the direct support of the associated equipment unless permission for further disclosure is expressly granted in writing.

**WJ-9205 SIGNAL MONITOR
REVISION A CHANGE 1**

TITLE: INSTRUCTION MANUAL FOR THE WJ-9205 SIGNAL MONITOR

MANUAL DATE: October 1989

**CHANGE 1
DATE:** February 1990

APPLICABILITY: All units.

**CHANGES/ERRATA
INFORMATION:** Changes refer to updates of the manual to cover design modifications. Errata refer to corrections or clarifications of information in the manual.

**CHANGE 1
SUMMARY:** This change provides additional information for the Remote Mnemonics Table.

ERRATA:

page 2-15

Add the following remote mnemonic after STS?.

ASCII	HEX	DEC	Description
STV(a)	C5	197	Stores selected trace to memory

**WJ-9205 SIGNAL MONITOR
REVISION A CHANGE 2**

TITLE: INSTRUCTION MANUAL FOR THE WJ-9205 SIGNAL MONITOR

MANUAL DATE: October 1989

**CHANGE 1
DATE:** May 1990

APPLICABILITY: All units.

**CHANGES/ERRATA
INFORMATION:** Changes refer to updates of the manual to cover design modifications. Errata refer to corrections or clarifications of information in the manual.

**CHANGE 2
SUMMARY:** This change corrects information in the Remote Mnemonics Table.

ERRATA:

page 2-2

Replace Figure 2-1 with the following:

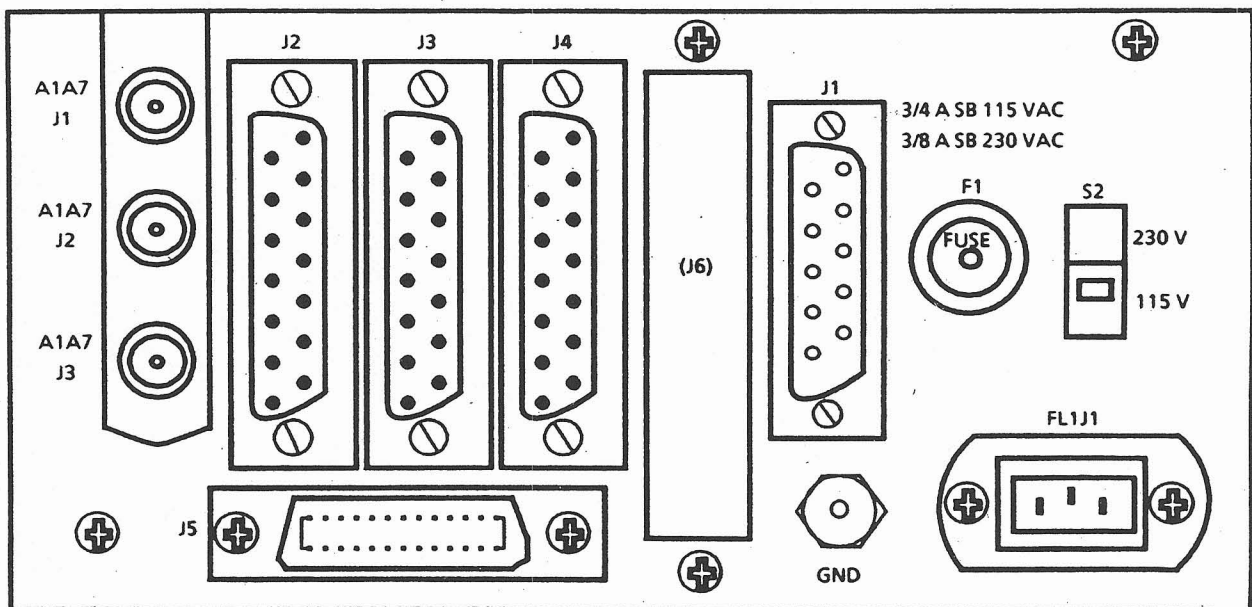

Figure 2-1. WJ-9205 Signal Monitor, Rear Panel Connectors

page 2-14

Change the description of INP(a) to the following:

Requests the hardware error.

Selects the input source.

1-3 = receiver inputs

4 = memory

5 = X-Y

0 = no input selected (off)

page 2-15

Change the description of SP? to the following:

Requests the selected span width (0-7)

Change the description of STS? to the following:

Requests device status

0 = not used

1 = power up

2 = hardware error

3 = operation or mode change

4 = not used

5 = command error (ERR23)

6 = SRQ set by this unit

7 = not used

**WJ-9205 SIGNAL MONITOR
REVISION A CHANGE 3**

TITLE: INSTRUCTION MANUAL FOR THE WJ-9205 SIGNAL MONITOR

MANUAL DATE: October 1989

**CHANGE 3
DATE:** May 1990

APPLICABILITY: All units.

**CHANGES/ERRATA
INFORMATION:** Changes refer to updates of the manual to cover design modifications. Errata refer to corrections or clarifications of information in the manual.

**CHANGE 3
SUMMARY:** This change corrects the WJ-9205 specifications and the Log/IF Detector performance test.

ERRATA:

page 1-3 Change the following specifications:

Attenuator	0 to 70 dB nominal, 0 to 60 dB in 10 dB steps
Vertical Display	70 dB Logarithmic
Sensitivity	-100 dBm input for minimum discernible signal

page 4-9

Change step 8 to the following:

8. Reset the signal monitor SPAN to 2.M. Set the signal generator output level to produce a response at the top graduation on the CRT. The level should be -27 dBm (± 2 dBm). Note the exact output level reading of the signal monitor. This reading is the reference level for the remaining graduation marks. Reduce the signal generator output until the display is at the next lower graduation mark. This level should be 10 dBm (± 2 dBm) lower than the previous graduation mark. Continue to reduce the signal generator output until the display is at the next lower graduation mark. For each of the remaining graduation marks, the output level should continue to decrease in multiples of 10 dBm lower than the reference level of -27 dBm (± 2 dBm). The first graduation mark is the reference level as noted above; the second graduation mark is 10 dBm (± 2 dBm) lower than the reference level; the third graduation mark is 20 dBm (± 2 dBm) lower than the reference level; etc.

TABLE OF CONTENTS

SECTION I

GENERAL DESCRIPTION

<u>Paragraph</u>		<u>Page</u>
1.1	Electrical Characteristics	1-1
1.2	Mechanical Characteristics	1-1
1.3	Equipment Supplied	1-2
1.4	Equipment Required But Not Supplied	1-2

SECTION II

INSTALLATION AND OPERATION

<u>Paragraph</u>		<u>Page</u>
2.1	Unpacking and Inspection	2-1
2.2	Installation	2-1
2.2.1	Connector Signals	2-1
2.2.1.1	Power Input (FL1J1)	2-1
2.2.1.2	Line Fuse (F1)	2-1
2.2.1.3	X-Y Input/Output (J1)	2-1
2.2.1.4	Receiver #1 Interface Connector (J2)	2-3
2.2.1.5	Receiver #2 Interface Connector (J3)	2-3
2.2.1.6	Receiver #3 Interface Connector (J4)	2-3
2.2.1.7	Remote Control (J5) (Optional)	2-3
2.2.1.8	Serial Data Port (J6) (Optional)	2-3
2.2.1.9	Receiver #1 IN (A1A7J1)	2-3
2.2.1.10	Receiver #2 IN (A1A7J2)	2-3
2.2.1.11	Receiver #3 IN (A1A7J3)	2-3
2.3	Equipment Malfunctions	2-4
2.4	Operation	2-4
2.4.1	Controls and Indicators (Standard Local Operation)	2-6
2.4.1.1	Push On/Off Power Switch	2-6
2.4.1.2	INTENSITY Control	2-6
2.4.1.3	TRACE Control	2-6
2.4.1.4	INPUT Selector	2-8
2.4.1.5	SPAN Control	2-8
2.4.1.6	RBW Control	2-9
2.4.1.7	ATTENUation Selector	2-9
2.4.1.8	PRESET Control	2-9
2.4.1.9	STORE Control	2-9
2.4.1.10	SHIFT Control	2-10
2.4.1.11	Voltage Selector Switch (S2)	2-11
2.4.1.12	Display	2-12

TABLE OF CONTENTS (Continued)

SECTION II

INSTALLATION AND OPERATION (Continued)

<u>Paragraph</u>		<u>Page</u>
2.5	Remote Operation	2-12
2.5.1	General Description	2-13
2.6	Errors	2-16
2.6.1	Local Operation	2-16
2.6.2	Remote Operation	2-16
2.7	Preparation for Reshipment	2-17

SECTION III

CIRCUIT DESCRIPTION

<u>Paragraph</u>		<u>Page</u>
3.1	General	3-1
3.2	Detailed Circuit Description	3-2
3.2.1	Type 796534-1 Microprocessor (A1A1)	3-2
3.2.2	Type 796537-1 Input/Output (A1A4)	3-5
3.2.3	Type 796535-1 Data Acquisition (A1A2)	3-8
3.2.4	Type 796536-1 Digital Refreshed Display/Timing Control (A1A3)	3-10
3.2.5	Type 796561-1 Input Control (A1A7)	3-12
3.2.6	Type 796562-1 Frequency Converter/Sweep (A1A8)	3-14
3.2.6.1	Type 796540-1 First LO/First Converter/Auto Center (A1A8A1)	3-15
3.2.6.2	Type 796541-1 Second LO/Second Converter (A1A8A2)	3-17
3.2.6.3	Type 796542-1 Second IF/RBW (A1A8A3)	3-18
3.2.6.4	Type 796790-1 Second IF/2 kHz RBW (A1A9) (Optional)	3-19
3.2.7	Type 796577-1 LOG IF Amplifier/Detector (A1A10)	3-20
3.2.8	Type 796538-1 Remote Interface Board (A1A5) (Optional)	3-21
3.2.9	Type 796539-1 Keyboard Display (A4)	3-21
3.2.10	Type 796782-1 High Voltage Power Supply/Video (A2)	3-23
3.2.10.1	Type 796545-1 High Voltage Power Supply/ Deflection Amplifier (A2A1)	3-23
3.2.11	Type 796771-1 Low Voltage Power Supply (A3)	3-25

TABLE OF CONTENTS (Continued)

SECTION IV

MAINTENANCE

<u>Paragraph</u>		<u>Page</u>
4.1	General	4-1
4.2	Cleaning and Lubrication	4-1
4.3	Inspection for Damage or Wear	4-1
4.4	Test Equipment Required	4-1
4.5	Troubleshooting and Fault Isolation Procedures	4-2
4.6	Performance Tests	4-3
4.6.1	Low Voltage Power Supply Performance Test	4-3
4.6.2	High Voltage Power Supply/Deflection AMP Performance Test	4-4
4.6.3	Microprocessor Performance Test	4-5
4.6.4	Keyboard and Display Performance Test	4-5
4.6.5	Sweep Width and Centering Performance Test	4-6
4.6.6	Input/Output Control Performance Test	4-7
4.6.7	LOG/IF Detector Performance Test	4-8
4.6.8	Input Attenuator Performance Test	4-9
4.6.9	Second IF/2 kHz RBW (A1A9) Performance Test (Optional)	4-10
4.6.10	Remote Interface (A1A5) Performance Test (Optional)	4-10
4.7	Alignment Procedures	4-11
4.7.1	Microprocessor (A1A1) Alignment	4-11
4.7.2	DRD/Timing Controller (A1A3) Alignment	4-11
4.7.3	High Voltage Power Supply (A2) Alignment	4-12
4.7.4	Frequency Converter (A1A8) Alignment	4-14
4.7.4.1	Second LO/Second Converter (A1A8A2) Alignment	4-15
4.7.4.2	Second IF/RBW (A1A8A3) Alignment	4-15
4.7.4.3	First LO/First Converter/Auto Centering (A1A8A1)	4-16
4.7.5	LOG IF AMP/Detector (A1A10) Alignment	4-16

SECTION V

REPLACEMENT PARTS LIST

<u>Paragraph</u>		<u>Page</u>
5.1	Unit Numbering Method	5-1
5.2	Reference Designation Prefix	5-1
5.3	List of Manufacturers	5-1
5.4	Parts List	5-4
5.5	Type WJ-9205 Signal Monitor (Main Chassis)	5-6
5.5.1	Type 796533-1 Motherboard Assembly (A1)	5-7
5.5.1.1	Type 796534-1 Microprocessor Assembly (A1A1)	5-8
5.5.1.2	Type 796535-1 Data Acquisition Assembly (A1A2)	5-10

TABLE OF CONTENTS (Continued)

SECTION V

REPLACEMENT PARTS LIST (Continued)

<u>Paragraph</u>		<u>Page</u>
5.5.1.3	Type 796536-1 DRD/Timing Controller Assembly (A1A3)	5-13
5.5.1.4	Type 796537-1 Input/Output Assembly (A1A4)	5-15
5.5.1.5	Type 796538-1 Remote Interface Assembly (Optional) (A1A5)	5-17
5.5.1.6	Type 796561-1 Input Control Assembly (A1A7)	5-18
5.5.1.6.1	Type 796500-1 Input Selector/Step Attenuator Assembly (A1A7A1)	5-19
5.5.1.6.2	Type 796544-1 Input Filter Assembly (A1A7A2)	5-21
5.5.1.7	Type 796562-1 Frequency Converter/Sweep Assembly (A1A8)	5-22
5.5.1.7.1	Type 796540-1 First LO/First Converter/ Auto Centering Assembly (A1A8A1)	5-23
5.5.1.7.2	Type 796541-1 Second LO/Second Converter Assembly (A1A8A2)	5-27
5.5.1.7.3	Type 796542-1 Second IF/RBW (10 kHz) Assembly (A1A8A3)	5-29
5.5.1.8	Type 796790-1 Second IF/2 kHz RBW Assembly (Optional) (A1A9)	5-31
5.5.1.8.1	Part 381939-1 Second IF/2 kHz RBW P.C. Board	5-32
5.5.1.9	Type 796577-1 LOG IF Amplifier/Detector Assembly (A1A10)	5-33
5.5.1.9.1	Type 796506-2 LOG IF/Detector Assembly (A1A10A1)	5-34
5.5.2	Type 796782-1 High Voltage Power Supply/Video (A2)	5-37
5.5.2.1	Type 796545-1 High Voltage Power Supply/ Deflection Amplifier Assembly (A2A1)	5-38
5.5.3	Type 796771-1 Low Voltage Power Supply Assembly (A3)	5-41
5.5.4	Type 796539-1 Keyboard Display Assembly (A4)	5-42

LIST OF TABLES

SECTION I

<u>Table</u>		<u>Page</u>
1-1	WJ-9205 Signal Monitor, Specifications	1-3

SECTION II

<u>Table</u>		<u>Page</u>
2-1	Table of Connectors	2-2
2-2	Table of Controls and Indicators	2-4
2-3	Error Messages	2-11
2-4	Remote Mnemonics	2-14

TABLE OF CONTENTS (Continued)

LIST OF TABLES (Continued)

SECTION III

<u>Table</u>		<u>Page</u>
3-1	Device Address Selection	3-4
3-2	Interrupts	3-8

SECTION IV

<u>Table</u>		<u>Page</u>
4-1	Test Equipment Required	4-1
4-2	WJ-9205 Troubleshooting Table	4-2
4-3	Low Voltage Power Supply Voltages	4-4
4-4	Pushbutton Performance Verification	4-5
4-5	SPAN and Sweep Width	4-7
4-6	WJ-9205 Signal Monitor Alignment Settings	4-11

LIST OF ILLUSTRATIONS

SECTION I

<u>Figure</u>		<u>Page</u>
1-1	WJ-9205 Signal Monitor	1-0
1-2	Outline Drawing of the WJ-9205 Signal Monitor	1-4

SECTION II

<u>Figure</u>		<u>Page</u>
2-1	WJ-9205 Signal Monitor, Rear Panel Connectors	2-2
2-2	WJ-9205 Signal Monitor, Front Panel Controls and Indicators	2-5
2-3	CRT Displays for Different Traces	2-7
2-4	Test Pattern CRT Display	2-10
2-5	Configuration of IEEE-488 Data Bus	2-12

TABLE OF CONTENTS (Continued)

LIST OF ILLUSTRATIONS (Continued)

SECTION III

<u>Figure</u>		<u>Page</u>
3-1	WJ-9205 Signal Flow Block Diagram	3-2
3-2	Microprocessor Block Diagram	3-3
3-3	Input/Output Block Diagram	3-6
3-4	Data Acquisition Block Diagram	3-8
3-5	DRD/Timing Control Block Diagram	3-10
3-6	Input Control Block Diagram	3-12
3-7	Input Select/Step Attenuator Block Diagram	3-13
3-8	Input Filter Block Diagram	3-14
3-9	Frequency Converter/Sweep Assembly Block Diagram	3-15
3-10	First LO/First Converter/Auto Centering Block Diagram	3-16
3-11	Second LO Converter Block Diagram	3-18
3-12	Second IF/RBW Block Diagram	3-18
3-13	Optional Second IF/2 kHz RBW Block Diagram	3-19
3-14	LOG IF Detector Block Diagram	3-20
3-15	Remote Interface Block Diagram	3-22
3-16	High Voltage Power Supply Block Diagram	3-24
3-17	Low Voltage Power Supply Block Diagram	3-26

SECTION IV

<u>Figure</u>		<u>Page</u>
4-1	Power Supply Performance Test, Equipment Connections	4-4
4-2	Input/Output Performance Test, Equipment Connections	4-7
4-3	LOG/IF Detector Performance Test, Equipment Connections	4-8
4-4	DRD/Timing Control Alignment, Equipment Connections	4-12
4-5	Typical Test Waveform	4-13
4-6	X-Y Alignment, Equipment Connections	4-14
4-7	Converter/LOG Detector Alignment, Equipment Connections	4-15

SECTION V

<u>Figure</u>		<u>Page</u>
5-1	WJ-9205 Signal Monitor, Front View	5-0
5-2	WJ-9205 Signal Monitor, Rear View	5-0
5-3	WJ-9205 Signal Monitor, Top View	5-5

TABLE OF CONTENTS (Continued)

LIST OF ILLUSTRATIONS (Continued)

SECTION VI

SCHEMATICS

<u>Figure</u>		<u>Page</u>
6-1	Type 796533-1, Motherboard Assembly (A1)	
	Schematic Diagram 580534 (Sheet 1 of 2)	6-1
6-1	Type 796533-1, Motherboard Assembly (A1)	
	Schematic Diagram 580534 (Sheet 2 of 2)	6-3
6-2	Type 796534-1, Microprocessor Assembly (A1A1)	
	Schematic Diagram 580474	6-5
6-3	Type 796535-1, Data Acquisition Assembly (A1A2)	
	Schematic Diagram 580508	6-7
6-4	Type 796536-1, DRD/Timing Controller Assembly (A1A3)	
	Schematic Diagram 580521	6-9
6-5	Type 796537-1, Input/Output Assembly (A1A4)	
	Schematic Diagram 580551	6-11
6-6	Type 796538-1, Remote Interface Board (A1A5) (Optional)	
	Schematic Diagram 580560	6-13
6-7	Type 796561-1, Input Control Assembly (A1A7)	
	Schematic Diagram 381158	6-15
6-8	Type 796500-1, Input Selector/Step Attenuator Assembly (A1A7A1)	
	Schematic Diagram 480755	6-17
6-9	Type 796544-1, Input Filter Assembly (A1A7A2)	
	Schematic Diagram 381196	6-19
6-10	Type 796562-1, Frequency Converter/Sweep Assembly (A1A8)	
	Schematic Diagram 480970	6-21
6-11	Type 796540-1, First LO/First Converter/Auto Centering Assembly (A1A8A1), Schematic Diagram 580511	6-23
6-12	Type 796541-1, Second LO/Second Converter Assembly (A1A8A2)	
	Schematic Diagram 380992	6-25
6-13	Type 796542-1, Second IF/RBW (10 kHz) Assembly (A1A8A3)	
	Schematic Diagram 480881	6-27
6-14	Type 796790-1, Second IF/2 kHz RBW Assembly (A1A9) (Optional)	
	Schematic Diagram 481466	6-29
6-15	Type 796577-1, LOG IF Amplifier/Detector Assembly (A1A10)	
	Schematic Diagram 381088	6-31
6-16	Type 796506-2, LOG IF/Detector Assembly (A1A10A1)	
	Schematic Diagram 580454	6-33
6-17	Type 796782-1, High Voltage Power Supply/Video (A2)	
	Schematic Diagram 381891	6-35
6-18	Type 796545-1, High Voltage Power Supply/Deflection Amplifier Assembly (A2A1), Schematic Diagram 580528	6-37

TABLE OF CONTENTS (Continued)

LIST OF ILLUSTRATIONS (Continued)

SECTION VI

SCHEMATICS (Continued)

<u>Figure</u>		<u>Page</u>
6-19	Type 796771-1, Low Voltage Power Supply Assembly (A3) Schematic Diagram 381840	6-39
6-20	Type 796539-1, Keyboard Display Assembly (A4) Schematic Diagram 580502	6-41
6-21	Type WJ-9205 Signal Monitor, Main Chassis Schematic Diagram 480791	6-43

SECTION I

GENERAL DESCRIPTION

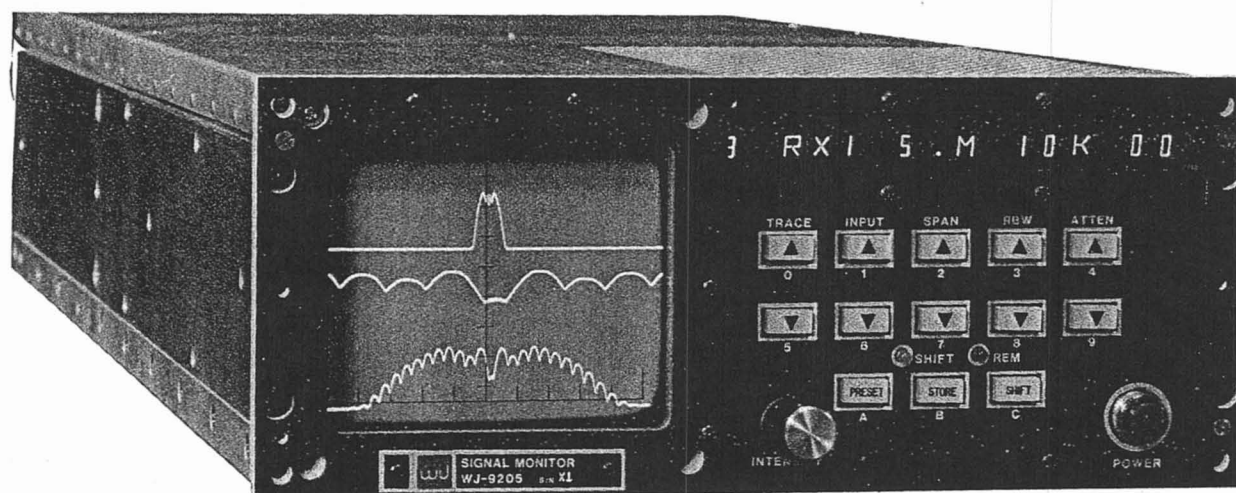

Figure 1-1. WJ-9205 Signal Monitor

SECTION I**GENERAL DESCRIPTION****1.1 ELECTRICAL CHARACTERISTICS**

The WJ-9205 Signal Monitor is designed as a companion unit for the WJ-8615D VHF/UHF Receiver, but may also be used with other receivers having a 21.4 MHz IF output. It utilizes the latest state-of-the-art technology to provide a wide range of monitoring and signal analysis capabilities. The monitor contains its own low- and high-voltage regulated power supplies, and operates from 115 or 230 Vac through its fused input. When operating the WJ-9205 Signal Monitor with WJ-8615D receivers, whose operating frequencies have been extended beyond 500 MHz, an additional input to the signal monitor for each extended receiver must be connected. This interface cable consists of two 15-socket D-type connectors that link pins 2 and 6 of the receiver's AUX connector (J11) to pins 2 and 6 of the signal monitor's RECEIVER #1, RECEIVER #2, or RECEIVER #3 connectors (J2, J3, or J4, respectively). This cable provides a TTL LOW signal when the receiver is operating within its normal frequency range or a TTL HIGH when it is operating within its extended frequency range. This indicates when the signal monitor must compensate with spectrum inversion associated with the frequency extension process.

The signal monitor has microprocessor based control circuitry to provide non-flickering digitally refreshed displays of one, two or three traces, while monitoring the sweep and signal circuitry to provide virtually adjustment-free operation. Common adjustments such as sweep rate and centering are performed automatically to display an optimum trace.

The WJ-9205 Signal Monitor accepts inputs from up to three receivers and displays spectrum traces for up to three inputs simultaneously, within 2.5 MHz above and below the receiver tuned frequency, on its 4.0 inch (diagonal) CRT. An accurate logarithmic range of 70 dB is provided for signal display. From the front panel controls or by the IEEE-488 remote interface, the signal monitor may be programmed to display one, two or three traces, with independently selected display parameters for each trace channel. Each trace is individually programmed for frequency span, display resolution, signal attenuation and signal source. Any of the input sources can be assigned to any of the traces and the frequency span may be set for spans ranging from 50 kHz to 5 MHz in a 1-2-5 calibrated sequence and 0 Hz. The standard resolution bandwidth of the display is 10 kHz, with a second selectable resolution bandwidth available as an option.

Where detailed signal analysis is required, multiple traces, each programmed with different display parameters, may be assigned to the same input source. With a broad frequency span assigned to one trace, a wideband overview of the entire input spectrum (up to 5 MHz) may be viewed. The remaining traces may then be set for narrower frequency spans to provide more detailed narrowband traces.

One 9-pin D-type connector is provided on the rear panel of the signal monitor which permits a large screen X - Y display monitor to be used with the WJ-9205.

1.2 MECHANICAL CHARACTERISTICS

The WJ-9205 Signal Monitor is housed in a 3.5 inch high by 8.25 inch wide package which extends 20 inches into a standard 19-inch equipment rack. It may be mounted together

with a WJ-8615D Receiver, a second signal monitor, or a half-rack blank panel. The combined package mounts into a standard 19-inch equipment cabinet using the supplied mounting kit.

The main chassis top, bottom, front, rear and internal compartment panels are constructed of aluminum. With the exception of the ac input voltage selector switch (S2), all switches, controls and indicators are on the front panel of the unit.

1.3 EQUIPMENT SUPPLIED

The equipment supplied consists of the WJ-9205 Signal Monitor, detachable line cord, three 15-pin connectors, one 9-pin connector, and a 3/4 amp or 3/8 amp slo-blow fuse. Additional equipment supplied includes an alignment tool, five extender boards and an extender cable to permit troubleshooting and/or maintenance procedures.

1.4 EQUIPMENT REQUIRED BUT NOT SUPPLIED

To obtain full use of the signal monitor, one or more WJ-8615D receivers should be utilized. However, the signal monitor may be used with other manufacturer's receivers, providing a pre-filtered 21.4 MHz IF signal is available. One coaxial cable with BNC connectors is needed for each WJ-8615D Receiver connected to the signal monitor. Up to three (3) separate receivers can be monitored. Specifications are given in Table 1-1.

Table 1-1. WJ-9205 Signal Monitor, Specifications

Cathode Ray Tube (CRT)	4-inch Diagonal Screen, P-31 Phosphor Standard (Short Persistence)
Sweep Span	0 Hz and 50 kHz to 5 MHz (1-2-5 sequence)
Sweep Rate	Automatic, 25 ms - 200 ms
Sweep Linearity	10%
Resolution Bandwidth	10 kHz, approximately (second optional front panel selectable resolution Bandwidths available)
Input:	
Input Impedance	50 Ohms Nominal
Input Frequency	21.4 MHz, ± 2.5 MHz
Input VSWR	1.5:1 or less
Input Level Maximum	+20 dBm without damage
Attenuator	0 - 70 dB in 10 dB calibrated steps
Vertical Display	Logarithmic, 70 dB calibrated
Centering Control	Automatic
Sensitivity	100 dBm input for minimum discernible signal
Third Order Intercept	+15 dBm typical
LO Radiation	-80 dBm maximum
Input Supply Voltage	115/230 Vac, $\pm 10\%$, 48-420 Hz
Power Consumption	Approximately 40 watts
Temperature Range:	
Operating	0°C to 50°C
Nonoperating	-20°C to 80°C
Dimensions:	
Width	8.25 inches (20.9 cm)
Height	3.5 inches (8.9 cm)
Depth	20 inches (50.8 cm)
Weight	18 lbs. (8.2 Kg), approximately

SECTION II
INSTALLATION AND OPERATION

SECTION II

INSTALLATION AND OPERATION

2.1 UNPACKING AND INSPECTION

Examine the shipping carton for damage before unpacking the equipment. If the carton exterior appears to be damaged, attempt to have the carrier's agent present during the unpacking of the equipment. If this is not possible, and if equipment damage is evident, retain all packing material and shipping containers for the carrier's inspection. Also, verify that the equipment supplied is as listed on the packing slip. Contact the Watkins-Johnson Company, Communication Electronics Technology Division, Gaithersburg, Maryland or your Watkins-Johnson representative with details of any discrepancy or shortage.

2.2 INSTALLATION

The WJ-9205 Signal Monitor is designed to mount in one half of a standard equipment rack. The unit occupies 3.5 inches of vertical rack space and extends 20 inches into the rack. Do not depend solely on the front panel mountings to support the unit. Use an approved type of slide, such as Johnathon Type QD110, or other hardware to support the monitor in the equipment rack.

Access to the rear panel is recommended so that input and output connections can be changed conveniently, if desired. The rear panel connections are described in Table 2-1. As a reference for the rear panel connectors, see Figure 2-1.

NOTE

Before applying power to the unit, verify that the selected line voltage for the system matches the utilized line voltage.

2.2.1 CONNECTOR SIGNALS

2.2.1.1 Power Input (FL1J1) — The power input connector provides the ac power input to the signal monitor. It will support line voltages of 115 Vac or 230 Vac as determined by the setting of the line voltage selector switch (S2). In either position, the power line frequency may range from 48 - 420 Hz.

2.2.1.2 Line Fuse (F1) — The line fuse and fuse housing provide a 3/4 amp slo-blow fuse for 115 Vac or a 3/8 amp slo-blow fuse for 230 Vac power input.

2.2.1.3 X-Y Input/Output (J1) — This 9-socket D-type connector provides for the X and Y axis of the signal monitor display to be connected to an external monitor. It also permits using the WJ-9205 as an X-Y Monitor with an external X-Y Input Source, such as a WJ-9206 Signal Monitor or a WJ-8617B Receiver with the signal monitor option (Option A) installed.

Table 2-1. Table of Connectors

Connector	Type	Function
FL1J1 Power Input F1 Fuse	3 Prong Slo-Blow	Power Input 115/230 Vac $\pm 10\%$, 48 - 420 Hz Houses 3/4 amp for 115 Vac or 3/8 amp for 230 Vac
J1 X-Y IN/OUT	9 Pin D	Connects X and Y axis of the Signal Monitor display to an external monitor.
J2 Interface RCVR #1	15 Pin D	Interface Connector for Receiver #1
J3 Interface RCVR #2	15 Pin D	Interface Connector for Receiver #2
J4 Interface RCVR #3	15 Pin D	Interface Connector for Receiver #3
J5 Remote Control	IEEE-488	Remote Control Port (Optional)
J6 Serial Data Port	RS-232 or RS-422	Future expandability. (Not presently used.)
A1A7J1 IF IN RCVR #1	BNC	Provides 50 ohm input to a 21.4 MHz IF signal from Receiver #1
A1A7J2 IF IN RCVR #2	BNC	Provides 50 ohm input to a 21.4 MHz IF signal from Receiver #2
A1A7J3 IF IN RCVR #3	BNC	Provides 50 ohm input to a 21.4 MHz IF signal from Receiver #3

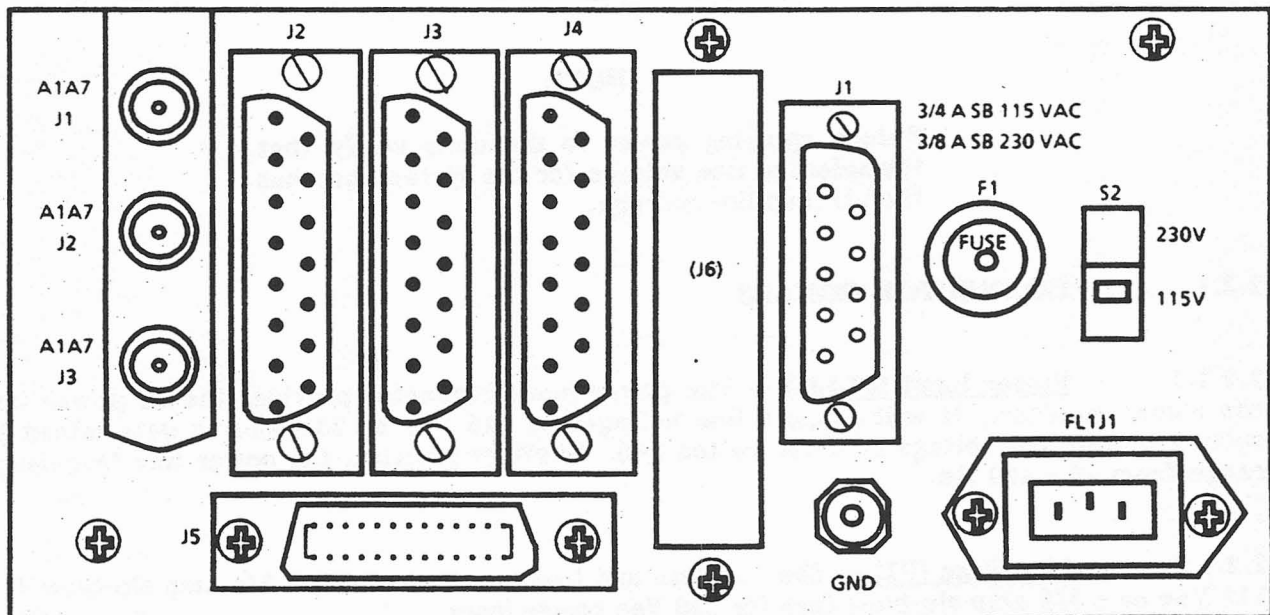

Figure 2-1. WJ-9205 Signal Monitor, Rear Panel Connectors

2.2.1.4 **Receiver #1 Interface Connector (J2)** — This 15-pin D-type connector is used to connect Receiver #1 to the Signal Monitor when Receiver #1 is a WJ-8615D Receiver whose frequency range has been extended to 500 MHz. Figure 2-1 depicts the pin configuration. As shown, pin 1 is the bottom pin of the left column and pin 9 is the bottom pin of the right column. Pin 6 accepts a HIGH or LOW TTL signal. Pin 2 is ground. See paragraph 1.4.

2.2.1.5 **Receiver #2 Interface Connector (J3)** — This 15-pin D-type connector is used to connect Receiver #2 to the Signal Monitor when Receiver #2 is a WJ-8615D Receiver whose frequency range has been extended to 500 MHz. Figure 2-1 depicts the pin configuration. As shown, pin 1 is the bottom pin of the left column and pin 9 is the bottom pin of the right column. Pin 6 accepts a HIGH or LOW TTL signal. Pin 2 is ground. See paragraph 1.4.

2.2.1.6 **Receiver #3 Interface Connector (J4)** — This 15-pin D-type connector is used to connect Receiver #3 to the Signal Monitor when Receiver #3 is a WJ-8615D Receiver whose frequency range has been extended to 500 MHz. Figure 2-1 depicts the pin configuration. As shown, pin 1 is the bottom pin of the left column and pin 9 is the bottom pin of the right column. Pin 6 accepts a HIGH or LOW TTL signal. Pin 2 is ground. See paragraph 1.4.

2.2.1.7 **Remote Control (J5) (Optional)** — This IEEE-488 type multipin connector provides the control interfacing between the WJ-9205 Signal Monitor and a suitable external computer or other remote controlling device using a standard IEEE-488-1978 remote interface. The installation of the interface cables at this connector must comply with the specifications set forth by the IEEE-488-1978 Standard, as deviation from this standard could result in unreliable bus operation. The interface connection may be installed in a STAR or DAISY CHAIN configuration.

2.2.1.8 **Serial Data Port (J6) (Optional)** — The RS-232 or RS-422 Port slot is available on the rear panel to provide for future expandability of the WJ-9205 Signal Monitor. This port is not presently supported by the standard Signal Monitor and requires additional software to be installed for it to be utilized. This option may be included at the time of purchase or the connector and required software can be installed later.

2.2.1.9 **Receiver #1 IN (A1A7J1)** — This BNC type connector provides a 50 ohm input impedance to a 21.4 MHz IF signal from Receiver #1, and is selected by pressing the INPUT up arrow or down arrow key on the front panel to display RX1 in the window.

2.2.1.10 **Receiver #2 IN (A1A7J2)** — This BNC type connector provides a 50 ohm input impedance to a 21.4 MHz IF signal from Receiver #2, and is selected by pressing the front panel INPUT up arrow or down arrow key to display RX2 in the window.

2.2.1.11 **Receiver #3 IN (A1A7J3)** — This BNC type connector provides a 50 ohm input impedance to a 21.4 MHz IF signal from Receiver #3, and is selected by pressing the INPUT up arrow or down arrow key on the front panel to display RX3 in the window.

2.3 EQUIPMENT MALFUNCTIONS

The WJ-9205 Signal Monitor was thoroughly inspected, tested, and factory adjusted for optimum performance prior to shipment. If any malfunctions are encountered after following the recommended installation procedures, **paragraph 2.2**, verify that the inter-unit cables are installed properly and that the correct input signals are present at the proper jacks. Maintenance and troubleshooting of the unit can be aided utilizing the procedures outlined in **Section IV** of this manual. Contact your Watkins-Johnson representative or the Watkins-Johnson Company, Communication Electronics Technology Division, Gaithersburg, Maryland prior to undertaking any corrective maintenance action, to prevent the possibility of voiding the warranty.

2.4 OPERATION

The WJ-9205 Signal Monitor provides a visual indication of spectrum for the 21.4 MHz IF signals from one, two or three separate receivers simultaneously on its 4.0 inch (diagonal) CRT. Operation is controllable from the front panel controls or via its IEEE-488 remote interface and a suitable controller. The various switches, controls and indicators used on the monitor during local operation are discussed in the following paragraphs. **Table 2-2** lists the controls and indicators. With the exception of the ac input voltage selector switch, all controls and indicators are on the front panel of the unit. See **Figure 2-2** as a reference for the location of the front panel controls and indicators.

Table 2-2. Table of Controls and Indicators

Control/Indicator	Description
<u>Controls</u>	
POWER	Applies power to the Signal Monitor.
INTENSITY	Adjust CRT Trace Brightness.
TRACE	Selects Trace number 1, 2 or 3.
INPUT	Selects input source: Receiver #1, Receiver #2, Receiver #3, Memory, X-Y or turns the trace off.
SPAN	Selects the Frequency Span. (0 to 5 MHz in 1-2-5 sequence.)
RBW	Selects 10 kHz Resolution Bandwidth or second other optional resolution Bandwidth.
ATTEN	Selects the amount of attenuation.
PRESET	Recalls previously stored parameters.
STORE	Stores in memory the present displayed parameters and the associated image.
SHIFT.	Redefines the keypad for special functions. See paragraph 2.4.1.10 .
Voltage Selector (S2)	Located on the rear panel, selects either 115 Vac or 230 Vac Input.

Table 2-2. Table of Controls and Indicators (Continued)

Control/Indicator	Description
Indicators	
Digital Display	These LEDs display the selected parameters: Trace, Input, Span, RBW and Attenuation. In addition, they indicate failure conditions.
SHIFT	This LED indicates that the SHIFT key has been pressed to enable shifted functions, refer to paragraph 2.4.1.10 for a description of these functions.
REM	This LED indicates when unit is in remote control. Remote control is selected by pressing the SHIFT key and then pressing the STORE key. Refer to paragraph 2.4.1.10.

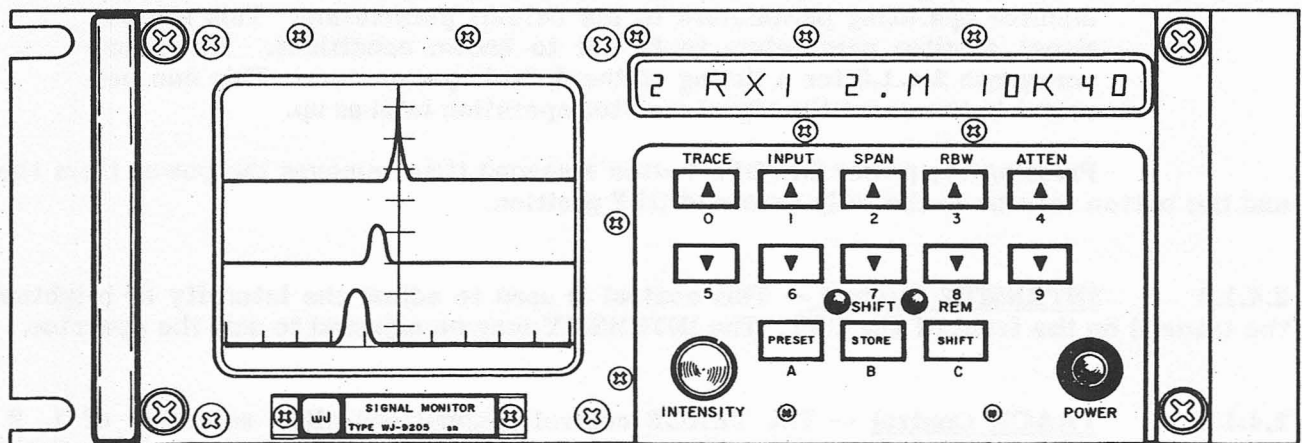

Figure 2-2. WJ-9205 Signal Monitor, Front Panel Controls and Indicators

2.4.1 CONTROLS AND INDICATORS (STANDARD LOCAL OPERATION)

The keyboard consists of ten buttons labeled 0 to 9, as shown in **Figure 2-2**. Buttons 0 to 4 have up arrows imprinted on them, while buttons 5 to 9 have down arrows. Each button pair (0-5, 1-6, 2-7, 3-8, 4-9) causes the value in the display directly above the buttons to cycle either up or down the number of times the button is pressed. The top buttons (0 to 4) cause the number to get larger or the display to cycle up. The bottom buttons (5 to 9) cause the number to get smaller or the display to cycle down.

When the button being pressed causes the data being displayed to reach its limit (either up or down), pressing the button any further does not effect the display, but causes an audible tone.

2.4.1.1 Push On/Off POWER Switch - This pushbutton switch applies power to the unit. Pressing the button a second time removes the power from the unit.

During the power up sequence, pressing the A or B pushbutton allows the unit to respectively perform the IEEE-488 address check (if installed), or set the default parameters listed in **paragraph 2.4.1.8**. These functions can be selected by pressing the pushbutton for the desired operation during the power up sequence.

A — Pressing this pushbutton during the signal monitor power up sequence enables the IEEE-488 address to be viewed or changed. When enabled, the IEEE-488 address is visible on the signal monitor front panel display as: **488 ADR XX .DCML** (XX=00 to 31). With this displayed on the front panel, pressing any two numbers changes the 488 address to the value of the new number. Pressing a third digit allows the new 488 address to be changed again. Pressing the A (PRESET) pushbutton enters the displayed 488 address as the signal monitor IEEE-488 address. If an invalid 488 address is selected, pressing the A key sets the 488 address to 01.

B — Pressing this key in during the power up sequence sets the signal monitor operating parameters to the default parameters. This allows signal monitor parameters to be set to known conditions. Refer to **paragraph 2.4.1.8** for a listing of the default parameters. This can be useful in the event the signal monitor operation latches up.

Pressing the power ON/OFF button a second time removes the power from the unit and the button returns to the fully extended OFF position.

2.4.1.2 INTENSITY Control — This control is used to adjust the intensity or brightness of the trace(s) on the front of the CRT. The INTENSITY may be adjusted to suit the operator.

2.4.1.3 TRACE Control — The TRACE control pushbuttons allow selection of 1, 2 or 3 Trace(s) to be displayed on the CRT. The vertical space on the CRT is divided evenly by the number of traces selected to be displayed. A single trace occupies the full screen and is calibrated with a gradicule. Selection of two or three traces respectively occupies 1/2 and 1/3 screen displays on the CRT. Refer to **Figure 2-3** for the CRT display for the different number of traces.

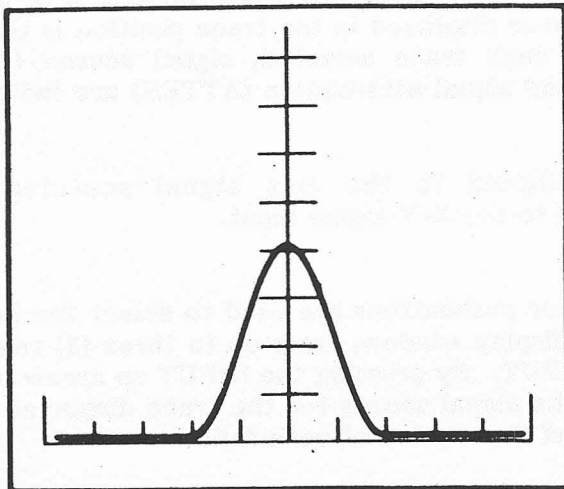

One Trace

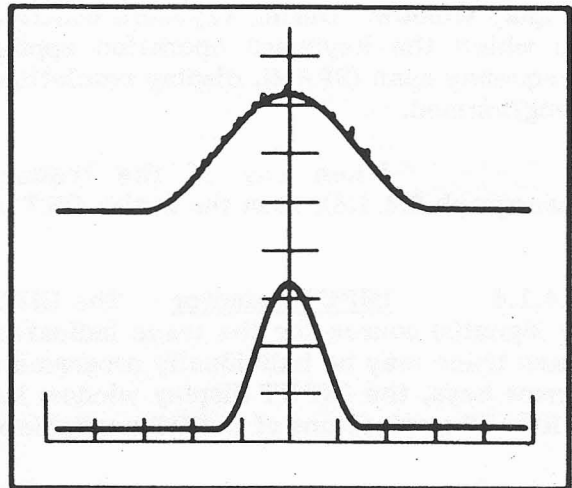

Two Traces

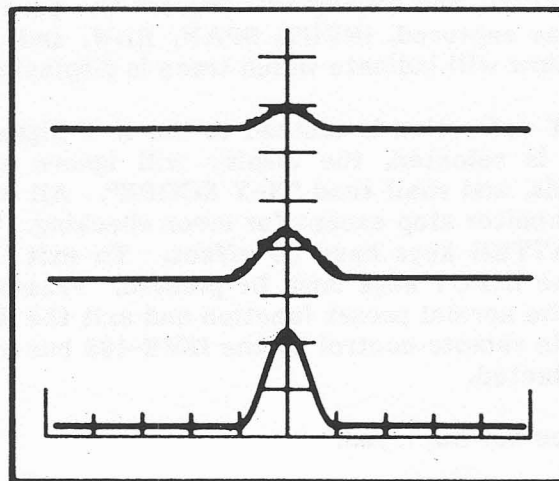

Three Traces

Figure 2-3. CRT Displays for Different Traces

Pressing the TRACE up arrow or down arrow keys enters the value 1, 2 or 3 in the display window. During keyboard control, the number displayed in the trace position is the trace to which the keyboard operation applies. For each trace selected, signal source (INPUT), frequency span (SPAN), display resolution (RBW) and signal attenuation (ATTEN) are individually programmed.

When any of the traces are assigned to the X-Y signal sourcing input (paragraph 2.4.1.4), then the entire CRT is devoted to the X-Y signal input.

2.4.1.4 INPUT Selector — The INPUT selector pushbuttons are used to select the receiver IF signal(s) source for the trace indicated in the display window, from up to three (3) receivers. Each trace may be individually programmed for INPUT. By pressing the INPUT up arrow or down arrow keys, the INPUT display window indicates the signal source for the trace displayed on the CRT. The selections of INPUT available and a brief description of each follow:

RX1 — IF Signal from Receiver #1 is selected.

RX2 — IF Signal from Receiver #2 is selected.

RX3 — IF Signal from Receiver #3 is selected.

M-Z — Stored Frame of Data in memory is selected. When in M-Z mode for INPUT, the display will present the parameters under which the data was captured, INPUT, SPAN, RBW, and ATTEN. The trace display window will indicate which trace is displaying the M-Z data.

X-Y — CRT deflection is sourced to the X-Y Signal Inputs. When the X-Y mode is selected, the display will ignore the arrangement of display fields, and shall read "X-Y SCOPE". All internal functions of the signal monitor stop except for error checking. The TRACE, SPAN, RBW and ATTEN keys have no effect. To exit 'X-Y SCOPE' mode, either of the INPUT keys must be pressed. Pressing the PRESET key will cause the normal preset function and exit the X-Y mode. The unit can be put in remote control by the IEEE-488 bus even if 'X-Y SCOPE' has been selected.

OFF — Trace not displayed.

2.4.1.5 SPAN Control — The SPAN control pushbuttons are used to select the frequency span of the trace shown in the display window. Each trace may be individually programmed for frequency span. By pressing the SPAN up arrow or down arrow key, the width of the trace is incremented or decremented from 0 kHz to 5 MHz. The LED display window, above the keys, shows the selected frequency span. The choices are: 000, 50 kHz, .1 MHz, .2 MHz, .5 MHz, 1. MHz, 2. MHz and 5. MHz. Choosing a span of 000 provides a center tuned frequency of 21.4 MHz. A span of 000 can be used to observe modulation on a received signal.

2.4.1.6 **RBW Control** — The RBW control pushbuttons are used to select the Resolution Bandwidth of the trace shown in the display window. Each trace may be programmed individually, when the optional second Resolution Bandwidth has been installed, by pressing the up arrow or down arrow button to the desired selection. Without this option installed, the standard unit utilizes 10 kHz as the only selection. Pressing the increment or decrement buttons will result in an audible tone and the display will warn "OPTION NOT INST".

2.4.1.7 **ATTENUATION Selector** — The Attenuation selector pushbuttons provide attenuation of incoming signals in 10 dB steps. Each trace may be individually programmed for the level of attenuation. By pressing the ATTEN up arrow or down arrow key, the attenuation of the signal is incremented or decremented in 10 dB steps. The LED display window, directly above the keys, displays the selected level of attenuation. The attenuation range available is: 0 dB, 10 dB, 20 dB, 30 dB, 40 dB, 50 dB, 60 dB and 70 dB. Note that the attenuation is performed to the actual incoming signal(s), so the trace is also reduced in amplitude by the amount of attenuation selected.

2.4.1.8 **PRESET Control** — The PRESET control button causes the signal monitor operating parameters to be reset to parameters stored in sustained memory. If no preset parameters have been entered or if sustained memory is lost, the signal monitor will be set to the following default parameters:

<u>Trace</u>	<u>Single Trace</u>
Input Source	Receiver #1
Span	5 MHz
RBW	10 kHz
Attenuation	0 dB
488 Address	Determined by switch setting

To store operating parameters in memory, first set the signal monitor to the desired status. Next, press the SHIFT key and then press the PRESET key. The operating parameters present at the time the SHIFT and PRESET keys were pressed are now stored in sustained memory. This allows operating parameters to be changed and then by pressing the PRESET key to return to a known preset operating status.

2.4.1.9 **STORE Control** — The STORE control key causes the Signal Monitor to store the current input frame and parameters selected for the INPUT (RCVR #1, RCVR #2, or RCVR #3) from any of the three traces. This data is stored in the display memory. Only one frame and its associated parameters can be stored in memory at any one time. When a new input is selected for memory, the memory contents are overwritten so that only the last stored selection remains in memory. The stored frame and parameters can be recalled and displayed on any trace by selecting the M-Z INPUT.

When the INPUT for a trace is switched to M-Z (where Z can be equal to Z, 1, 2, or 3), the stored input frame and parameters will be displayed. M-Z indicates that the memory has been cleared and no INPUT or parameters have been stored in memory. M-1 indicates the frame and parameters stored were stored for the RCVR #1 input. M-2 indicates that the stored frame and parameters were those selected for the RCVR #2 input. M-3 indicates that the frame and parameters stored were those selected for RCVR #3.

2.4.1.10 SHIFT Control — The SHIFT control button is used, along with one other button, to allow additional functions to be selected. Pressing the SHIFT key illuminates the SHIFT LED on the signal monitor front panel. When this LED is illuminated, the SHIFT function is enabled. Pressing a second key enables the selected SHIFT function. After pressing the second key, the SHIFT LED is extinguished indicating that the SHIFT function has been performed. The following list describes the various SHIFT functions.

SHIFT/STORE — Pressing the SHIFT key and then pressing the STORE key allows the operator to toggle between local control and remote control. When remote control is selected the REM LED illuminates. In local control, the LED is extinguished. The current control mode is maintained in battery sustained memory.

SHIFT/PRESET — Pressing the SHIFT pushbutton and then pressing the PRESET pushbutton causes the current operating parameters of each trace to be stored in memory. Once stored, the parameters for each trace can be changed as desired. Then by pressing PRESET, all three signal monitor traces are set to the parameters stored in memory.

SHIFT/1 — Pressing the SHIFT and then the 1 pushbuttons causes the CRT to temporarily display a known test pattern on the selected trace display. The test pattern is a series of four ramp waveforms. Refer to Figure 2-4 for the ramp waveform.

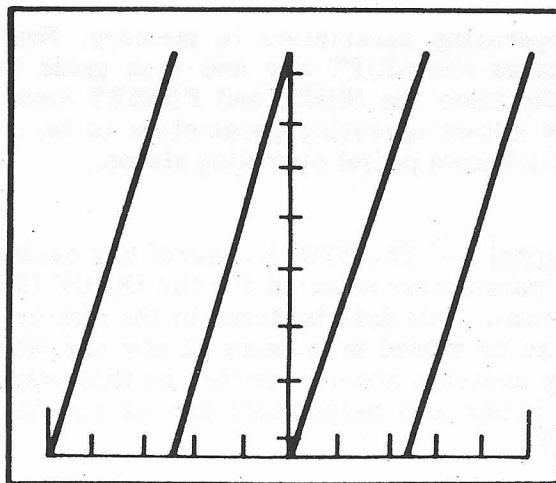

Figure 2-4. Test Pattern CRT Display

SHIFT/2 — Pressing the SHIFT and then the 2 keys cause any existing error messages to be displayed on the front panel display. An error condition is indicated on the front panel via the presence of decimal points in place of blank spaces. The decimal points disappear when the SHIFT/2 keys are pressed and the error codes are displayed. Refer to Table 2-3 for the list of error messages. SHIFT/2 has no effect if no error conditions exist.

Table 2-3. Error Messages

Message	Cause of Error
DRD FAILURE	DRD not interrupting
-15 V LOW	-15 Vdc supply voltage too low
-15 V HIGH	-15 Vdc supply voltage too high
DA FAILURE	Data acquisition not interrupting
+5 V LOW	+5 Vdc supply voltage too low
+5 V HIGH	+5 Vdc supply voltage too high
NO LOCK-VCO	VCO fails to lock
+8 V LOW	+8 Vdc supply voltage too low
+8 V HIGH	+8 Vdc supply voltage too high
+15 V LOW	+15 Vdc supply voltage too low
+15 V HIGH	+15 Vdc supply voltage too high
488 SELF TEST	IEEE-488 fails self test
RAM FAILURE	Sustained memory test failure
EPROM CKSUM	EPROM fails checksum comparison
2K V LOW	-2K Vdc supply voltage too low
-2K V HIGH	-2K Vdc supply voltage too high
OPTION NOT INST	An Option must be installed before the requested function can be performed
POWER UP	Power has been applied to the unit
UNKNOWN COM	Unimplemented 488 command
COM ERROR	488 Command error
INVALID PAR	Invalid 488 Request

NOTE

If an error has been sent to the display, the error message is not repeated unless the power is cycled off and on again or unless the SHIFT/2 keys are pressed. Decimal points are visible in the display until the error is cleared.

2.4.1.11 Voltage Selector Switch (S2) — The voltage selector switch, located on the rear panel, permits selection of either 115 Vac or 230 Vac line voltage input. Set the voltage selector switch in the voltage position closest to the line voltage utilized. Both the 115 V and 230 V position will support line voltages ranging from ±10% of the stated line voltage. In either position, the power line frequency may range from 48 to 420 Hz.

2.4.1.12 **Display** — An alphanumeric 16 character LED display provides visual indication of working parameter conditions. Refer to **Figure 2-2** for a typical alphanumeric display. The display is viewed through a display window which is located above the keypad on the front panel and divided into five fields. The display indicates the parameter setting: **TR** (Trace), **INPUT**, **SPAN**, **RBW** (Resolution Bandwidth), and **ATTEN** (Attenuation). The display is also used to display messages such as the product number, software version (**WJ-9205-X.X.X**) and to alert the operator of failure conditions. The position of each part of the display and spacing of the display is as follows:

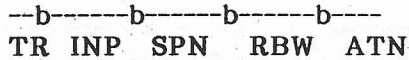

2.5 **REMOTE OPERATION**

The IEEE-488 Remote Interface provides talk and listen capabilities between the signal monitor and external equipment, such as calculators, minicomputers or other IEEE-488 equipped controlling devices. The data is transferred between units in a bit-parallel, byte-serial form, utilizing sixteen interconnection lines. These lines consist of eight bi-directional data bus lines, three data byte transfer lines and five management lines. Data or address information is transferred between devices, utilizing the data bus lines. Refer to **Figure 2-5** for the pin configuration of the standard IEEE-488 Data Bus.

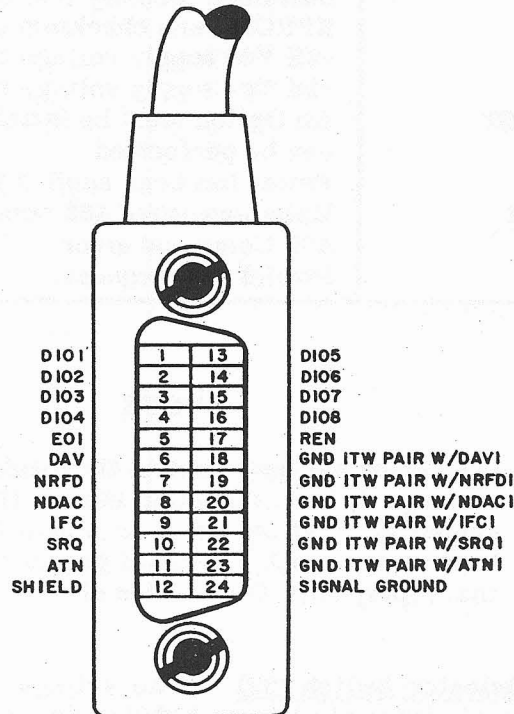

Figure 2-5. Configuration of IEEE-488 Data Bus

The data byte transfer lines indicate the availability and validity of the information on the data bus lines; if the devices are ready to accept data; and if the data has been accepted. The interface management lines specify whether the data bus lines are carrying data or address information; request service; clear the interface; and indicate the end of a transfer sequence. The capabilities of the IEEE-488 Interface include:

<u>Function Description</u>	<u>IEEE-488-1978 Subsets</u>
● Source handshake	(SH1)
● Acceptor handshake	(AH1)
● Basic talker with serial poll	(T6)
● Basic listener with serial poll	(L4)
● Service request	(SR1)
● Device clear	(DC1)

Essentially, this means that the monitor can talk or listen when commanded by the controller. It can also issue a service request notifying the controller when it needs service.

Two types of data transfer are supported on the WJ-9205 Signal Monitor. One type of data transfer on the IEEE-488 interface bus is ASCII. This type of transfer utilizes ASCII mnemonics to control the monitor. The termination may be CR, LF (Carriage Return, Line Feed) or LF (Line Feed) or EOI (End or Identify) set on the last character of the transfer. These mnemonics may be strung together using a semicolon. Another type of data transfer supported by the WJ-9205 Signal Monitor is binary. This type of data transfer allows single information bytes to control the monitor. In the binary operation, a command or group of commands must end with EOI (End or Identify) set on the last byte of the command. Commands may not be strung together with a semicolon or terminated with CR (Carriage Return) or LF (Line Feed). The ASCII operation format tends to be self-documenting and easy to understand. Binary, on the other hand, lessens the number of bytes that must be transferred and has a faster execution speed. In the ASCII format, the message consists of a series of data bytes that form one of the mnemonics listed in Table 2-4. Each byte is one ASCII character of the mnemonic. When the mnemonic contains a variable value, the mnemonic is followed by a number representing that value. Each digit of the number is applied as a separate ASCII character. In the binary format, the mnemonic is one 8-bit byte containing the hexadecimal code corresponding to the mnemonic. When a variable value is to be included in the message, it is sent as one or more additional data bytes, representing the binary or hexadecimal value. During ASCII operation, only ASCII commands are valid and only ASCII responses are returned. In binary operation, only binary commands are valid and only binary responses are returned.

2.5.1 GENERAL DESCRIPTION

The command columns of Table 2-4 depict messages that can be sent to the WJ-9205 Signal Monitor as an active listener. Responses are messages returned when the monitor is an active talker. ASCII messages may be sent with embedded spaces or any combination of upper and lower case characters. In the binary mode, no blanks are allowed in the binary message. The system starts in ASCII mode and enters the binary mode by the receipt of the BIN command. The binary command 55 (HEX) (85 decimal) returns the system to the ASCII mode of operation.

In addition to the mnemonics, the monitor responds to the 488 defined commands of SDC (selected device clear) and DCL (device clear). These commands cause the monitor to do a power up reset, including clearing the message buffers and sending an SRQ.

Table 2-4. Remote Mnemonics

Command			Response			Description
ASCII	HEX	DEC	ASCII	HEX	DEC	
ATT(a)	7E(b)					Selects the input attenuation in 10 dB increments (0-7). Requests the input attenuation setting returns 0-7 for X0-70 dB of attenuation.
ATT?	80		ATT(a)	7E(b)		
BW(a)	4E(b)	78(b)				Selects the bandwidth slot (1-8). Requests the selected bandwidth slot (1-8).
BW?	9E	80	BW(a)	4E(b)	78(b)	
BWC?	9E	158	BWC(c)	9E(bb)	158(bb)	Requests the selected bandwidth size. ASCII returns are up to 4 digits max (in kHz), 9999 is the highest value and represents 9.9 MHz. Binary returns a 2-byte binary number (in kHz) with 65536 kHz as the highest value and represents 65 MHz.
CLH	C0	192				Re-enables reporting of hardware error(s) previously reported.
CLR	51	81				Select the default parameters, clears display RAM, clears program RAM, does not issue an SRQ.
ERR?	65(b)	101	ERR(a)	65(b)	101(b)	Requests the remote interface error.
HER?	C3	195	HER(aaaa)	C3(bbbb)	195(bbbb)	Requests the hardware error.
INP(a)	4B(b)	75				Selects the input source 1-3= receiver inputs 4 = memory 8 = X-Y 0 = no input selected (off)
INP?	4D	77	INP(a)	4B(b)		Requests the selected input source.
LLO	F9	249				Selects local lockout.
LLO/	FA	250				Returns to local control mode.
LLO?	FB	251				Requests lockout status.
			LLO	F9	249	In local lockout.
			LLO/	FA	250	In local control.

Table 2-4. Remote Mnemonics (Continued)

Command			Response			Description
ASCII	HEX	DEC	ASCII	HEX	DEC	
MSK(b)	BD(b)	189				Sets the device status mask. Each status byte bit may be masked off separately by writing a binary "1" in the corresponding location. <u>Bit</u> D7 Not Used D6 SRQ D5 Command Error (ERR 23) D4 Not Used D3 Operation or Mode Change D2 Hardware Error D1 Power Up D0 Not Used
RMT	81	129				Selects remote control mode.
RMT/	82	130				Selects local control mode.
RMT?	83	131				Requests control mode.
			RMT	81	129	In remote mode.
			RMT/	82	130	In local mode.
SP(a)	BA	186				Selects the span (0-7) 0 = autocenter
SP?	BC	188	SP(a)	BC(b)	186(b)	Requests the selected span width MHz = nnnM kHz = nnnK
STS?	92	146	STS(a)	92(b)	146(b)	Requests device status 0 1 = power up 2 = hardware error 3 = remote interface error 4 = busy 5 = busy 6 = SRQ set by this unit
STV(a)	C5	197				Stores selected trace to memory
TRC(a)	0C(b)	12				Selects the trace # (1-3).
TRC?	0E	14				Requests the trace #.
			TRC(a)	0C(b)	12	
VER?	0	0				Requests equipment type and software revision level.
			VER 9205	-X.X.X		

NOTES: a = ASCII number followed by a delimiter
 b = a single Binary number
 c = 4 bytes of ASCII data representing a number
 s = a string of messages separated by ; in response to a single query

2.6 ERRORS

2.6.1 LOCAL OPERATION

Should an error occur that is associated with the signal monitor during local operation, the display window will indicate the last error condition that has been reported. A list of the error numbers, conditions and display messages are found in Table 2-3. Pressing the SHIFT key and then pressing the 2 key causes the last error condition to be displayed. Pressing these two keys until no more errors are displayed, clears the error buffer and returns the signal monitor display to normal.

2.6.2 REMOTE OPERATION

During remote operation, errors are identified when either the ERR? or HER? query is sent. The ERR? query requests the signal monitor to send the status of the last remote or communication error. The signal monitor responds with an error response as: ERR X (X = 1- 7). The value of X is as follows:

<u>Value</u>	<u>Cause of Error</u>
1	Input buffer over run
4	Invalid argument or Out of range
6	"?" or "/" invalid for command
7	Invalid mnemonic or binary command

The response to the hardware error query (HER?) uses the following format: HER X1, X2, X3, X4. Where X is a decimal value (0-255) of a binary code. The following list indicates the byte, bit value, and corresponding error condition.

Byte X1

<u>Bit</u>	<u>Value</u>	<u>Error Condition</u>
0	1	DRD Failure
1	2	15V Line Low
2	4	15V Line High
3	8	DA Failure
4	16	5V Line Low
5	32	5V Line High
6	64	VCO Unlocked
7	128	+8V Line Low

Byte X2

<u>Bit</u>	<u>Value</u>	<u>Error Condition</u>
0	1	+8V Line High
1	2	+15V Line Low
2	4	+15V Line High
3	8	UART Self-test Failed
4	16	488 Self-test Failed
5	32	Not Used
6	64	RAM Failure
7	128	PROM Checksum Failed

Byte X3

<u>Bit</u>	<u>Value</u>	<u>Error Condition</u>
0	1	-2kV Line Low
1	2	-2kV Line High
2	4	Option Not Installed
3	8	Software Failure
4	16	Not Used
5	32	Not Used
6	64	488 Execution Error
7	128	488 Command Error

Byte X4

<u>Bit</u>	<u>Value</u>	<u>Error Condition</u>
0	1	488 Invalid Request
1	2	
2	4	
3	8	
4	16	(Bits 1-7 are not presently used.)
5	32	
6	64	
7	128	

2.7 PREPARATION FOR RESHIPMENT

If the unit must be prepared for reshipment, the packaging methods should follow the pattern established in the original shipment. If retained, the original materials can be reused to a large extent, or at least provide guidance for the repackaging effort.

SECTION III
CIRCUIT DESCRIPTION

SECTION III

CIRCUIT DESCRIPTION

3.1 GENERAL

The WJ-9205 Signal Monitor is a multi-trace, microprocessor-controlled signal monitor. The WJ-9205 provides from one to three signal traces with selectable resolution bandwidths. Signal activity displayed on the signal monitor traces are automatically centered and optimized. The signal monitor circuits can be divided into three sections: the RF section, the digital section, and the power/display section. These sections are interconnected via the Motherboard assembly (A1). The Motherboard provides the electrical and physical connections required for the signal monitor operation.

The WJ-9205 Signal Monitor is designed to provide a signal display for up to three WJ-8615 Receivers. The following paragraphs describe the path a signal takes through the signal monitor. This signal path is shown on Figure 3-1.

Received 21.4 MHz IF signals are applied to one of three BNC connectors (A1A7J1-A1A7J3) on the signal monitor rear panel. These connectors provide a 50 ohm impedance for the received signals. Signals at these connectors are directed to the Input Control assembly (A1A7). Signals applied to the Input Control module are applied to the Input Select/Step Attenuator (A1A7A1). This module determines which input signal is to be processed. The selected signal can be attenuated from 0 dB to 70 dB in 10 dB steps before being applied to the Input Filter assembly (A1A7A2).

Input Filter assembly (A1A7A2) provides isolation and low-pass filtering of the selected input signal. From the Input Filter assembly the signal is directed to the Frequency Converter/Sweep assembly (A1A8). The input signal is applied to J1 of the First LO/First Converter/Auto Center subassembly (A1A8A1). This subassembly mixes the RF signal from the Input Filter assembly with the 118.1 MHz First LO, producing a 96.7 MHz First IF. The First IF is bandpass filtered before being applied to the Second LO/Second Converter (A1A8A2). The Second LO/Second Converter low-pass filters the First IF signal before it is mixed with an 86 MHz signal, producing the 10.7 MHz Second IF. The Second IF is applied to the Second IF/10 kHz RBW subassembly (A1A8A3). This subassembly bandpass filters the 10.7 MHz Second IF before amplifying the IF signal. After amplification, the Second IF is again bandpass filtered, providing the video resolution bandwidth before being directed to the LOG IF Amplifier/Detector (A1A10). Post filtered 10.7 MHz Second IF signals are low-pass filtered before being buffered and applied to the successive detector network. The output of the successive detector network is amplified and applied to the LOG amplifier. The output voltage (0 to 5 Vdc) is applied to the display section to provide the vertical deflection for the CRT.

Control of the signal monitor operation is provided via the digital section. The digital section contains the operating program, the microprocessor, and the display memory storage. The Microprocessor assembly (A1A1) contains the operating program (stored in EPROM), the microprocessor and the bus controller devices. The microprocessor controls the signal monitor operation using the operating program stored in EPROM. The operating status of the signal monitor is stored in RAM. Timing for signal monitor operations is provided by the Microprocessor assembly. Data to and from the Microprocessor assembly pass through the Input/Output assembly (A1A4). Front panel control data, display data, synthesizer data, resolution bandwidth data, input selection, and attenuation selection all pass through the Input/Output assembly. Data is directed through the Input/Output module to the proper assembly.

The Data Acquisition assembly (A1A2) provides the 1024 data points the signal monitor uses to produce the video trace. The signal level at each of the 1024 data points is determined and converted from an analog level to a digital word and stored in the DRD (digitally refreshed display) memory. Digital Refreshed/Display Timing Control assembly (A1A3) stores 1024 discrete data points in memory. These data points are used to produce the video display.

The High Voltage Power Supply/Video assembly (A2) provides the voltages required to operate the CRT (cathode ray tube). Voltages provided by the High Voltage Power Supply include the filament voltage, the cathode voltage, the accelerator voltage, the high voltage sample voltage, and the horizontal and vertical voltages.

The Low Voltage Power Supply (A3) provides the supply voltages used by the other signal monitor assemblies.

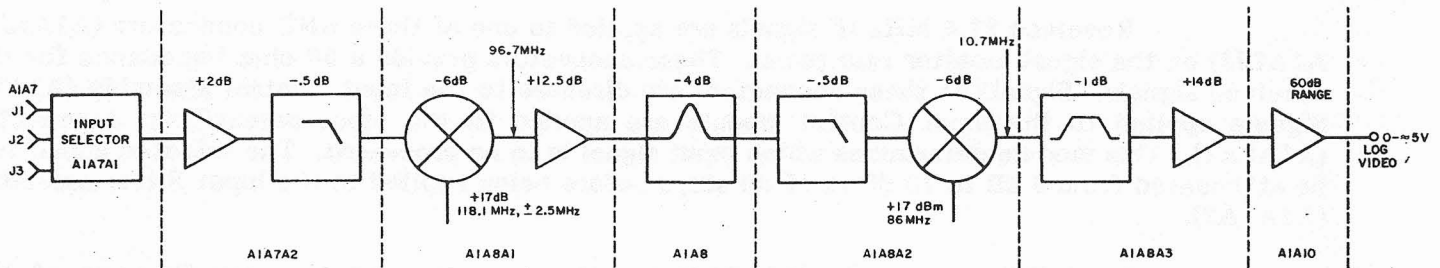

Figure 3-1. WJ-9205 Signal Flow Block Diagram

3.2 DETAILED CIRCUIT DESCRIPTION

3.2.1 **TYPE 796534-1 MICROPROCESSOR (A1A1)**

Refer to Figure 6-2 for the Type 795634-1 schematic diagram. The reference designation for the Microprocessor module is A1A1. Refer to Figure 3-2 for the Microprocessor block diagram.

The Microprocessor module (A1A1) contains the signal monitor operating software, the memory storage, and the software program for the signal monitor operation. Microprocessor U8 controls the operation of the signal monitor via the address bus lines (A0-A15) and the data bus lines (DI/O0-DI/O7). Using the address lines, the microprocessor selects one device on the bus to receive data from (read) or send data to (write). This allows the microprocessor to control the signal monitor operations. The logic level of the microprocessor read/write line (pin 36) determines whether the device addressed is written to or read from. When this line is High, the selected device is read from and when the line is Low, the device is written to. The microprocessor internally divides the 5.24 MHz oscillator frequency by four, producing a clock

frequency of 1.31 MHz. Two clock outputs are provided from the microprocessor, the quadrature clock (Q) and the enable clock (E). These clocks are used to establish and synchronize timing throughout the signal monitor circuits.

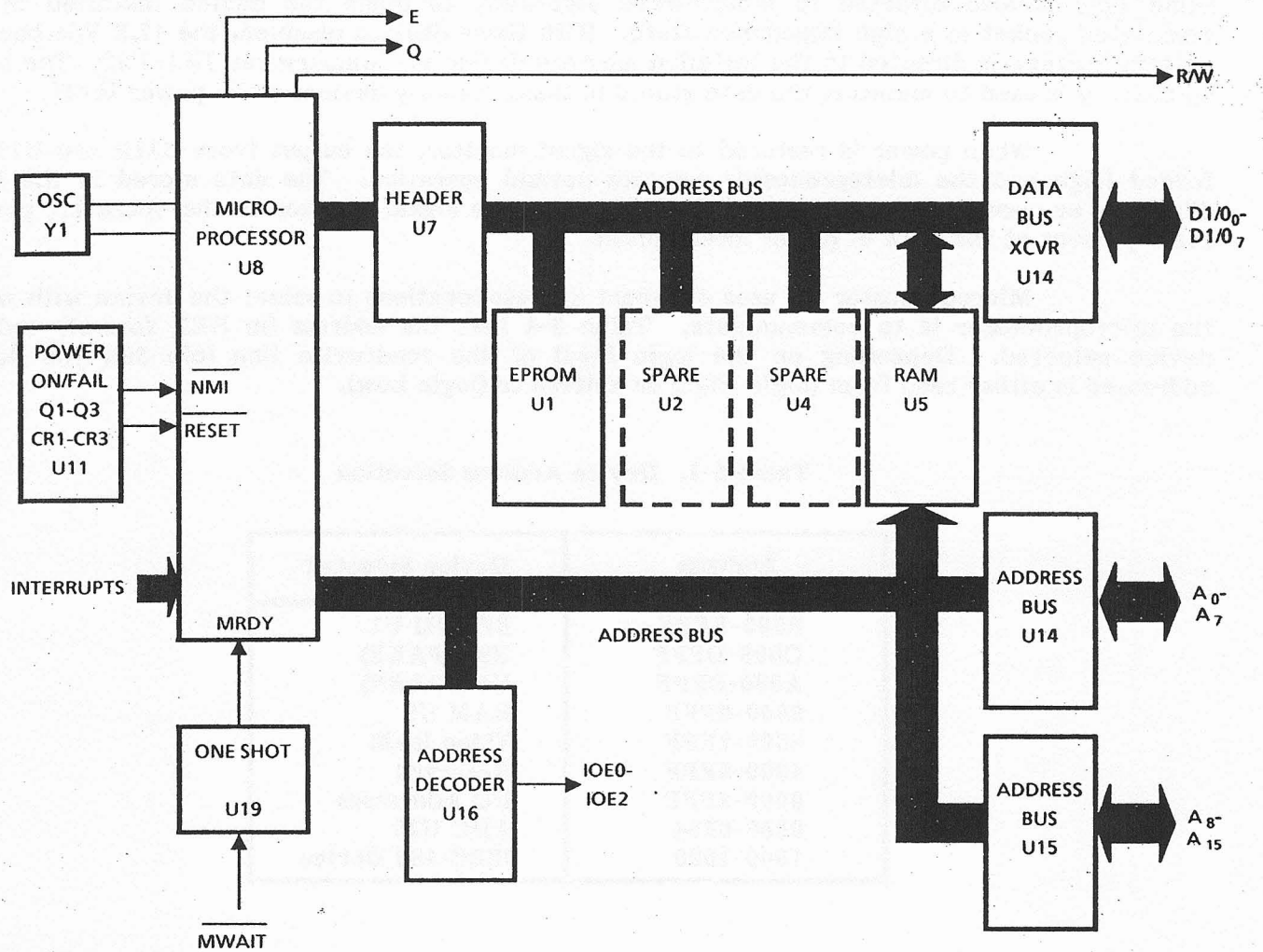

Figure 3-2. Microprocessor Block Diagram

The signal monitor operating program is contained in Erasable Programmable Read Only Memory (EPROM) U1. This device contains the operating software used to control the signal monitor operation. Random Access Memory (RAM) U5 stores the current signal monitor operating status. It also maintains the signal monitor operating status present at the time power is turned off. RAM memory is maintained via back-up battery BT1 and its associated circuitry.

When power is turned off, the +5 Vdc supply voltage drops below the accepted level. The change in voltage is sensed by the power up/down circuit (Q1-Q3, CR1-CR3, U11, and their associated components). When the supply voltage drops below the level established by R7, the power up/down circuit forces the output of U11E and U11F Low. This Low is applied to the NMI (non-maskable interrupt) and the RESET lines of microprocessor U8, halting its operation. This same Low is also directed to jumperwires JW5-JW7, to place the device installed in the associated socket in a high impedance state. With these devices disabled, the +2.8 Vdc back-up battery voltage is directed to the installed memory device via jumperwires JW1-JW3. The back-up battery is used to maintain the data stored in these memory devices while power is off.

When power is restored to the signal monitor, the output from U11E and U11F is forced High and the microprocessor resumes normal operation. The data stored in the RAM device is accessed by the microprocessor, returning the signal monitor to the operating parameters present at the time of power interruption.

Microprocessor U8 uses different address locations to select the device with which the microprocessor is to communicate. Table 3-1 lists the address (in HEX format) and the device selected. Depending on the logic level of the read/write line (pin 36), the device addressed is either read from (logic High) or written to (logic Low).

Table 3-1. Device Address Selection

Address	Device Selected
E000-FFFF	EPROM U1
C000-DFFF	U2 (SPARE)
A000-BFFF	U4 (SPARE)
8000-8FFF	RAM U5
6000-7FFF	Video RAM
4000-5FFF	Reserved
0000-3FFF	I/O Addresses
0080-0084	ADC U15
1000-1020	IEEE-488 Device

Address bus lines A0-A15 are connected to EPROM U1, RAM U5 (EPROM and RAM), address decoder U16, and bus drivers U14 and U15. Address decoder U16 further decodes the address, allowing five address lines to select one of eight devices. Bus drivers U13-U15 provide the required output level to drive the other modules connected to the address bus. The address bus lines are connected, via the Motherboard, to other modules within the signal monitor (SM). This allows the microprocessor to communicate with the other modules, providing overall control of the signal monitor operation.

Reading the following address locations, the microprocessor can determine the operating status of the signal monitor.

<u>Read Address</u>	<u>Parameter Checked</u>
0088	Keyboard Input
0089	Resolution Bandwidth
008A	Interrupt Status

Using the following write addresses, the microprocessor can update the parameters located in the addressed memory location. After the microprocessor writes to the address, data can be sent to change the current parameter.

<u>Write Address</u>	<u>Parameter Addressed</u>
0090	Lock/Hold
0091	Reset Clock
0092	Reset Keyboard
0098	Input Selector/Attenuator
0099	Resolution Bandwidth
009A	Synthesizer
009B	LED Display Position
009C	LED Display Data
009D	LED Display Controller
009E	Interrupt Mask
0800-080C	Video Display Data

Inactive data and address bus lines are pulled High via pull-up resistors U3, U6, and U9. The pull-up resistors prevent the bus lines from being loaded by inactive lines.

Flip-flop U19 acts as a pulse stretcher, introducing a time delay that allows the optional IEEE-488 module time to process data from slower devices that may be on the external IEEE-488 bus.

3.2.2 TYPE 796537-1 INPUT/OUTPUT (A1A4)

The reference designation for the Input/Output module (I/O) is A1A4. Refer to **Figure 6-5** for the Type 796537-1 I/O module schematic diagram. Refer to **Figure 3-3** for the Input/Output block diagram.

Signal monitor data and control signals pass through the I/O (Input/Output) module. The Input/Output module provides the interface between the different sections and modules. Signals passing through the I/O module include front panel display data, pushbutton data, address data, remote commands, interrupts, resolution bandwidth (RBW) data, input selection, and attenuator control. Audible beeper LS1 is located on this module. The beeper produces an audible tone when an invalid parameter is attempted to be entered or when a parameter is attempted to be set beyond its limit.

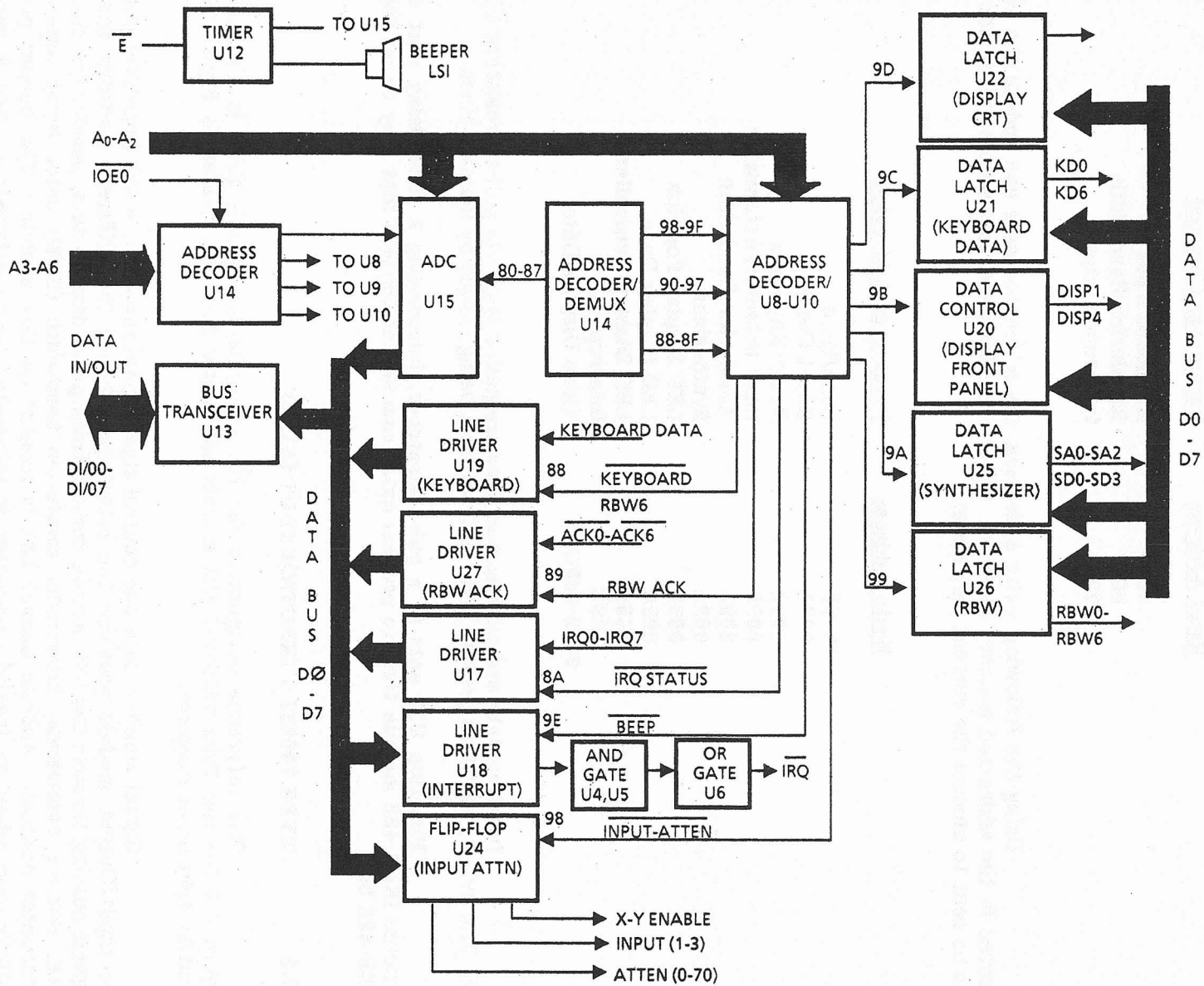

Figure 3-3. Input/Output Block Diagram

Data is transferred to or from the I/O module via the eight data bus lines (DI/O0-DI/O7). Data is applied to the I/O module data bus via connector P1 pins 7-14. Bi-directional data transceiver U13 provides the necessary bus drive level. The logic level of the read/write line (connector P1 pin 36) determines the direction of data flow through U13. With the read/write line Low, external data is applied from the data bus to the I/O module. When the read/write line is High, data is directed out of the I/O module onto the data bus.

Address select lines A0-A6 determine which device on the I/O module is enabled. Address lines A0-A2 are used to select one of the eight inputs of analog-to-digital converter U15 and enable one of the eight outputs from decoder/demultiplexers U8-U10. Address lines A3-A6 are used to select the different outputs of decoder/demultiplexer U14. Outputs from U14 determine which device (U8-U10) is enabled.

Outputs from decoder/demultiplexers U8-U10 are used to latch data to or from hardware interface registers or to reset interrupt flip flops. The following list indicates the output enabled, the device selected, the interrupt to be reset, data to be read or updated, and the function performed.

<u>Output</u>	<u>Device Selected</u>	<u>Data Updated</u>	<u>Function</u>
U8 Y0	Octal Buffer U19	Keyboard	Read
U8 Y1	Octal Buffer U27	RBW Acknowledge	Read
U8 Y2	Octal Buffer U17	IRQ Status	Read
U9 Y0	Buffer/Driver U11B	Lock/Hold	Read
U9 Y1	Buffer/Driver U11A	Timer Reset	Write
U9 Y2	Buffer/Driver U7A	Keyboard IRQ Reset	Reset
U10 Y0	Buffer/Driver U24	Input/Attenuation	Reset
U10 Y1	Buffer/Driver U26	RBW Selection	Write
U10 Y2	Buffer/Driver U25	Synth. Address/Data	Write
U10 Y3	Buffer/Driver U20	Display Address	Write
U10 Y4	Buffer/Driver U21	Display Data	Write
U10 Y5	Buffer/Driver U22	Display Control and Beeper	Write
U10 Y6	Buffer/Driver U18	Interrupt Enable Mask	Write

Analog-to-digital converter (ADC) U15 is used to perform the internal BITE testing of the power supplies. If any of the tested voltages are out of tolerance, an error code is generated and the failed voltage is temporarily displayed on the front panel. The digital output from U15 is present on the data bus after conversion is completed.

The timer, lock detect, and the interrupts (connector P1 pins 60-67) are sent to line driver U17 and to AND gates U4 and U5. Interrupts from the remote interfaces, data acquisition, the keyboard, or the digitally refreshed display (if enabled) cause an interrupt (IRQ) to be output (connector P1 pin 44), to the microprocessor. The interrupt indicates that a status change has occurred. Microprocessor A1A1 U8 directs the IRQ chip U17 to output IRQ data to DI/O0 through DI/O7 (P1, pins 7 through 14). The microprocessor then reads these data lines to interpret what device caused the interrupt. Table 3-2 lists the interrupt and the function causing the interrupt to be set.

Table 3-2. Interrupts

Interrupt	Cause of Interrupt
IRQ 0	Keyboard pushbutton pressed
IRQ 1	DRD refresh complete
IRQ 2	Data acquisition cycle complete
IRQ 3	IEEE-488 remote I/O message
IRQ 4	Remote serial message
IRQ 5	Synthesizer lock detector
IRQ 6	Waiting for slower device
IRQ 7	Not used

3.2.3 TYPE 796535-1 DATA ACQUISITION (A1A2)

Refer to Figure 6-3 for the Type 796535-1 Data Acquisition assembly schematic diagram. The reference designation for the Data Acquisition assembly is A1A2. Refer to Figure 3-4 for the Data Acquisition block diagram.

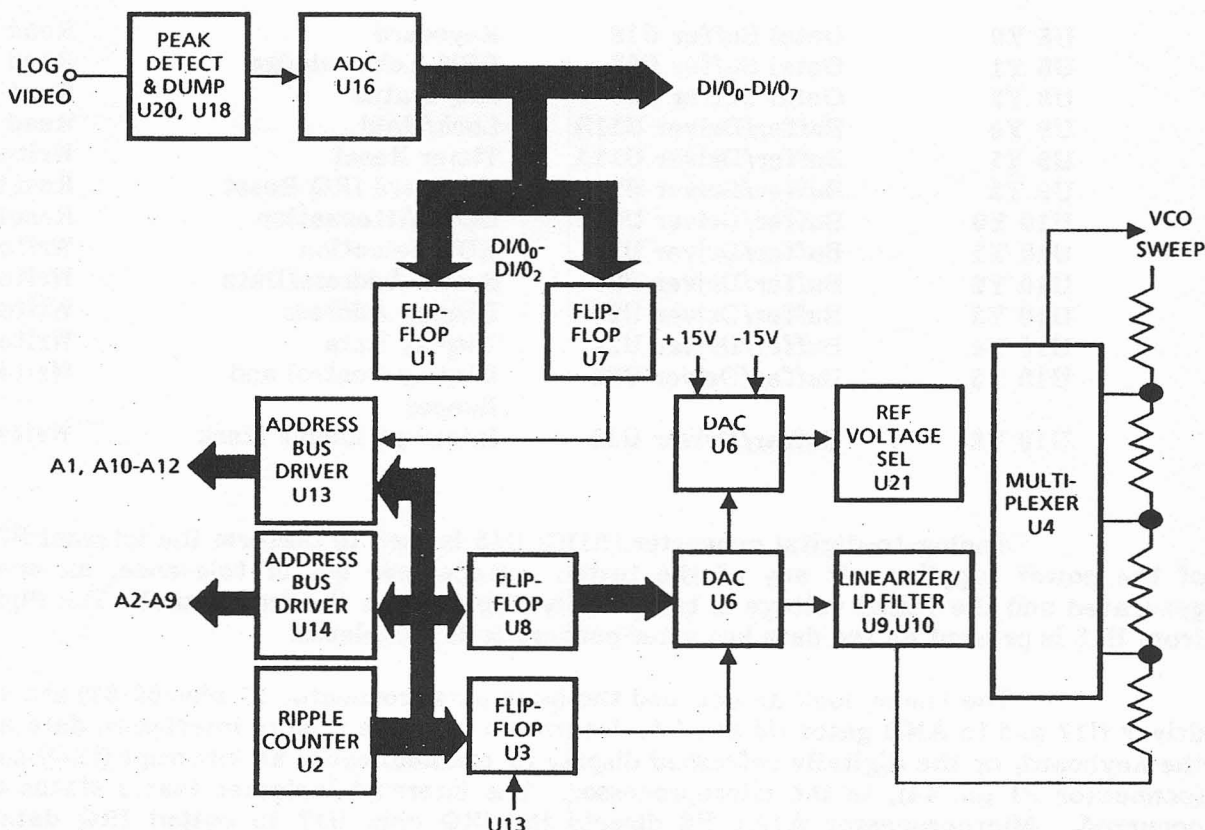

Figure 3-4. Data Acquisition Block Diagram

The Data Acquisition assembly is composed of three major circuits: the peak detect and dump circuit, the ramp generator circuit, and the sweep generator circuit.

Operation of the Data Acquisition assembly is initiated by the microprocessor. Microprocessor assembly A1A1 sets the RST DA line (connector P1 pin 59) Low. This Low resets flip-flop U15A, which in turn resets binary counter U2. When U2 is reset, it begins counting up. At a count of 1024, an output pulse is present at Q11. This output pulse clocks U15A. With U15A clocked, its output changes state. This causes IRQ1 to be sent to the I/O module, indicating that data acquisition is complete and also resets U2. U2 begins counting up again when clocked by a Low on connector P1 pin 58 (ADDR INC). When U2 is clocked, it provides the sweep address and counts up to a count of 1024. Clocked outputs from U2 are applied to line drivers U13 and U14 and to flip-flops U3 and U8. Pulses from U3 and U8 are directed to digital-to-analog converter (DAC) U6. Analog voltage outputs from DAC U6 are amplified by U10A and low pass filtered before being applied to the voltage divider network (R13-R19). This voltage divider network provides the eight signal monitor sweep spans from 0 to 5 MHz. The VCO SWEEP output from U4 is routed to the Frequency Converter Sweep Assembly (A1A8).

The reference voltage for DAC U6 is either positive (+5 Vdc) or negative (-5 Vdc). Polarity of the reference voltage selection is determined by the position of jumperwire JW1. Connecting JW1 to the Y output of U21 selects the positive reference voltage. Connecting JW1 to the Y* output selects the negative reference voltage.

NOTE

On the WJ-8615 Receiver, a sweep reversal is encountered at frequencies above 500 MHz. To accommodate this sweep reversal the DAC reference voltage is reversed in the WJ-9205 Signal Monitor.

IN1 and IN2 are used to select the input source. Depending on the logic level at connector P2 pins 11 and 12, one of the three input sources is selected. The selected source is indicated via a Low at connector P2 pin 10, 9, or 8 for source 1, 2, or 3 respectively.

The LOG VIDEO signal at connector P2 pin 4 is amplified by U20A before being applied to electronic switch U18. Amplifier U20 (A and B), switch U18 (A and B), and their associated components form the peak detect and dump circuit. The input LOG VIDEO, from the LOG IF, is a voltage from 0 Vdc to slightly less than 5 Vdc.

The peak detect and dump circuit samples 1024 discrete data points and produces peak output for each data point. The peak voltage output is directed to analog-to-digital converter U16. U16 converts each peak data point to an 8-bit data word. Output data from U16 is present on the data input/output bus (DI/O0-DI/O7). This data is then stored in the digitally refreshed display (DRD) memory. Data lines DI/O0-DI/O2 are also applied to flip-flops U1 and U7. Data is sent to U1 to select the signal monitor sweep span. The data applied to U7 is directed to line drive U13 and onto the address bus.

3.2.4 TYPE 796536-1 DIGITAL REFRESHED DISPLAY/TIMING CONTROL (A1A3)

Refer to Figure 6-4 for the Type 796536-1 Digital Refreshed Display/Timing Control schematic diagram. The reference designation for the DRD/Timing Control is A1A3. Refer to Figure 3-5 for the DRD/Timing Control block diagram.

Digital Refreshed Display/Timing Controller A1A3 provides the memory storage for the video display and provides the timing circuits to produce the video display. Data and address information is received via connector P1 pins 7-30. The data bus connects U9, U15, U17, U20, and U24 together. The address bus interconnects U2, U3, U14, and U18. Using the address lines, the microprocessor enables one device on the address bus at a time. Address lines A1-A3 are used to enable one of seven outputs from U14. When the DRD/Timing Control module is written to, a Low from connector P1 pin 31 is present at OR gate U19B and at decoder/demultiplexer U14. With U14 pin 5 also Low, address lines A1-A3 determine which output from U14 is enabled. The enabled output from U14 is a logic Low. The Low is directed to the associated device as a clock or other control input. The following list indicates the output from U14 and the device affected by the output.

* Indicates Active Low Signal

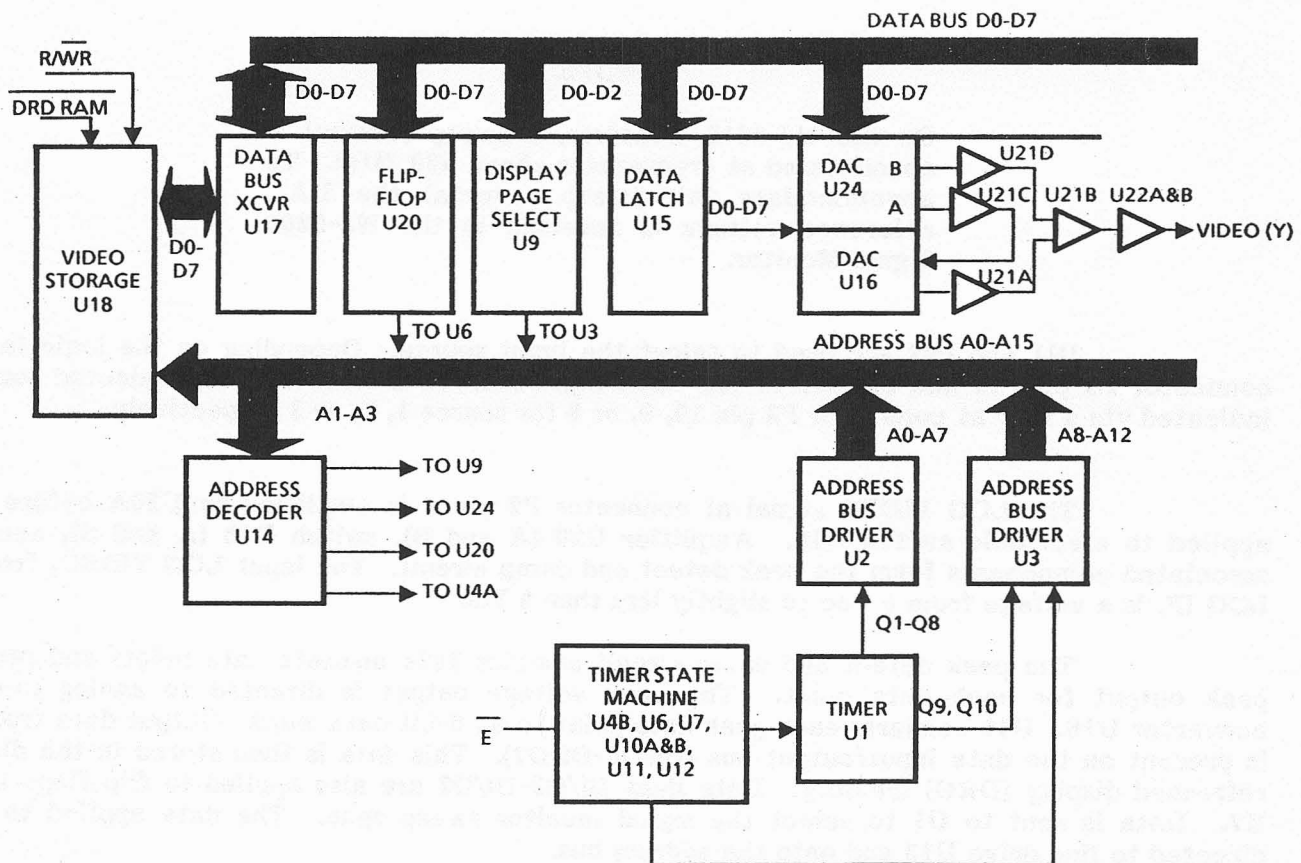

Figure 3-5. DRD/Timing Control Block Diagram

<u>Output</u>	<u>Function</u>	<u>Device Affected</u>
Y0	Clock	Flip-flop U9
Y1	Write Enable	DAC U24
Y2	Clock	Flip-flop U20
Y3	Reset	Flip-flop U4A
Y4	Reset	Flip-flop U15 (A1A2)
Y5	Interrupt	Line drive U17 (A1A4)
Y6	Clock	Flip-flop U1 (A1A2)
Y7	Grounded	None

Data from the data bus is directed through line driver U17. With a Low on U17 pin 1, data is directed from the B ports to the A ports. This allows data to be stored in memory device U18. U18 stores the 1024 data points for the video image. Each data point is written into U18 and stored. Once the data has been stored, the microprocessor writes to the DRD RAM address (6000-7FFF). With the DRD RAM line Low (connector P1 pin 49) and the read (RD) line Low, U18 directs data stored in its memory to line driver U17. The video data is directed through U17 onto the data bus.

Video data is directed to display page selector U9, to flip-flop U15 and to DAC U24. U9 is used to display the video signal for the selected trace. Display selected data from U9 is applied through U3 onto the address bus by a Low to High transition of the Q output from flip-flop U10B. The Low-to-High transition from U10B also clocks data from the data bus through U15 to DAC U16. Digital-to-analog converter U16 converts the digital video data to an analog voltage. This analog voltage is applied to either the inverting or noninverting input of U21B.

Video data present at the inputs of DAC U24 are converted to an analog voltage when the Y1 output from U14 is Low. When this occurs, U24 writes to either the A output or the B output. The output written to is determined by address line A0. Output A from U24 provides the reference voltage for DAC U16. Output B provides the other analog voltage input for U21B. The output from U21B is low pass filtered via U22A and U22B and their associated components before being applied to connector P2 pins 11 and 12 as the VIDEO (Y) for the CRT display. The SWEEP (X) output at connector P2 pins 7 and 8 is generated when the Y3 output from U14 is Low. The Low from U14 resets flip-flop U4A, clocking U27A. The Q output from U27A is directed out connector P1 pin 61 as the interrupt request. The output from U27A is directed to amplifier U22D and also to transistor Q1. From Q1, the output voltage is amplified by U23A and U23B before being applied out connector P2 pins 7 and 8 as the SWEEP (X) output for the CRT display.

Timing for the video display is provided by: U4B, U7, U6, U12, U11, U10A, and U10B. These devices form the timing control circuit. The timing circuit is initiated via the enable (E*) clock (connector P2 pin 38) being applied to counter U7. U7 starts counting up to a count of 1024. Outputs from U7 are directed to multiplexer U6, decoder/demultiplexer U12, and flip-flop U11. Data bus lines D0-D7 at U20 are used to select an input to U6 from counter U7. The output from U6 is sent through U11 to set flip-flop U10B. Other outputs from U11 are used to clock binary counter U1 or cause the Data Acquisition module (A1A2) to HOLD (connector P1 pin 58) or DUMP (connector P1 pin 57) the analog voltage level at the input to ADC U16.

3.2.5 TYPE 796561-1 INPUT CONTROL (A1A7)

Refer to Figure 6-7 for the Type 796561-1 Input Control assembly schematic diagram. The reference designation for the Input Control assembly is A1A7. Refer to Figures 3-6 thru 3-8 for the Input Control block diagram.

The Input Control assembly contains the Input Select/Step Attenuator (A1A7A1) and the Input Filter (A1A7A2). The Input Select/Step Attenuator (A1A7A1) selects the input signal source (J1 thru J3), which is the IF input from the receivers, for display on the signal monitor CRT. It also provides from 0 to 70 dB of attenuation of the received signal. Output signals from the Input Select/Step Attenuator are applied to the Input Filter module (A1A7A2). The Input Filter provides low pass filtering of the received input signal.

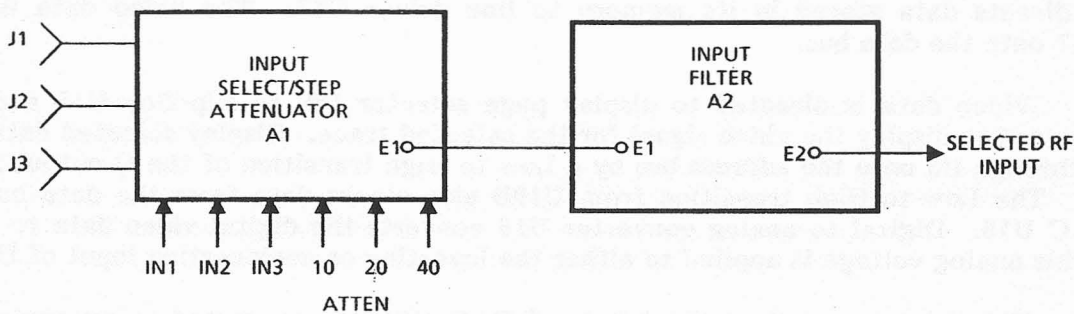

Figure 3-6. Input Control Block Diagram

Refer to Figure 6-8 for the Type 796500-1 Input Selector/Step Attenuation Assembly schematic diagram. The IF signals from the rear panel connectors (J1-J3) are capacitively coupled to a diode switching network. As shown on the block diagram (Figure 3-7) the input selection is controlled by signals IN1 thru IN3. To select INPUT 1 (J1), a Low logic level is applied to the input (pin 9 of connector P1). Refer to the following list for the INPUT selection.

Input Selection	E# of Input	Voltage Levels		
		IN1(E7)	IN2(E6)	IN3(E5)
A1A7J1	E11	L	H	H
A1A7J2	E12	H	L	H
A1A7J3	E14	H	H	L

The selected input is coupled by capacitor C29 to a three-step attenuation circuit. The attenuation circuits are switched in or out by the 10 dB(E4), 20 dB(E3), and 40 dB(E2) control signals. As shown by Figure 3-7, The 10 dB signal at E4 is used to switch the 10 dB attenuation circuit. A logic Low bypasses the attenuation resistor network and when E4 is High, the RF input is routed through the 10 dB attenuator. When E3 is Low, the 20 dB attenuation network is bypassed and when E3 is High, the input signal is routed through the 20 dB attenuator. When E2 is Low, the 40 dB attenuation network is bypassed and when E2 is High the input signal is routed through the 40 dB attenuator.

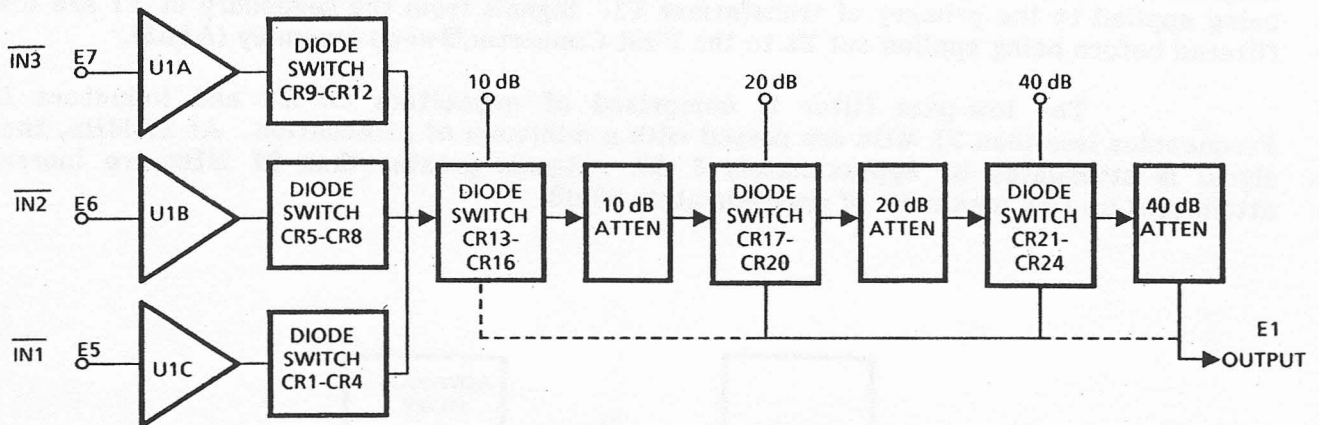

Figure 3-7. Input Select/Step Attenuator Block Diagram

For the example shown on Figure 3-7, E4 and E2 are both Low and results in the input signal being attenuated by 50 dB. The following list indicates the logic levels required to select attenuation levels from 10 dB to 70 dB.

Attenuation (in dB)	Logic Levels		
	E4	E3	E2
0	L	L	L
10	H	L	L
20	L	H	L
30	H	H	L
40	L	L	H
50	H	L	H
60	L	H	H
70	H	H	H

To select 10 dB of attenuation, a logic level High is applied to E4 (connector P1 pin 10). This logic level is resistively coupled to the inverting input of amplifier U2A and the noninverting input of amplifier U2D. A logic level High at E4 is inverted to a Low through U2A, reverse biasing CR13 and CR15. The logic level from E4 through U2D forward biases diodes CR14 and CR16. This directs the input signal through the 10 dB resistive network (comprised of R39, R40, R41). The input signal is capacitively coupled from one attenuator section to the next. Selecting an attenuation greater than 10 dB enables another section, or a combination of the three sections.

Whether attenuated or not, the selected INPUT signal is directed from E1 of A1A7A1 to E1 of the Input Filter (A1A7A2). Refer to Figure 6-9 for the Input Filter schematic diagram. The input signal is capacitively coupled to isolation, buffer amplifiers Q1 and Q2 before being applied to the primary of transformer T1. Signals from the secondary of T1 are low pass filtered before being applied out E2 to the First Converter/Sweep assembly (A1A8).

The low-pass filter is comprised of capacitors C1-C5 and inductors L1-L4. Frequencies less than 27 MHz are passed with a minimum of attenuation. At 27 MHz, the input signal is attenuated by approximately 3 dB. Signals greater than 27 MHz are increasingly attenuated up to a maximum of approximately 50 dB.

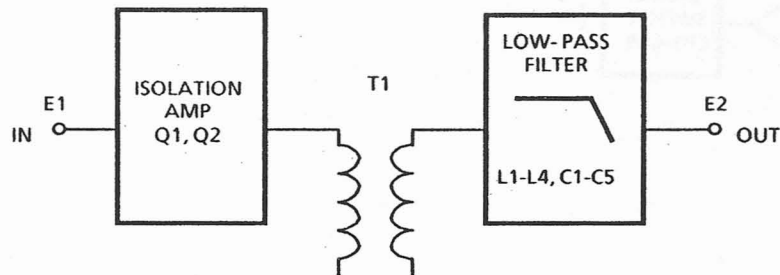

Figure 3-8. Input Filter Block Diagram

3.2.6 TYPE 796562-1 FREQUENCY CONVERTER/SWEEP (A1A8)

Refer to Figure 6-10 for the Type 796562-1 Frequency Converter schematic diagram. The reference designation for the Frequency Converter/Sweep assembly is A1A8. Refer to Figure 3-9 for the Frequency Converter/Sweep Assembly block diagram.

The Frequency Converter/Sweep assembly is comprised of three subassemblies and a bandpass filter. The three subassemblies are the First LO/First Converter/Auto Centering, the Second LO/Second Converter, and the Second IF/RBW. These subassemblies receive the selected IF input and mix the 21.4 MHz RF with the 118.1 MHz First LO frequency to produce the 96.7 MHz First IF. The First IF is bandpass filtered before being mixed with 86 MHz to produce the 10.7 MHz Second IF. The Second IF is bandpass filtered, providing a resolution bandwidth (RBW) of 10 kHz.

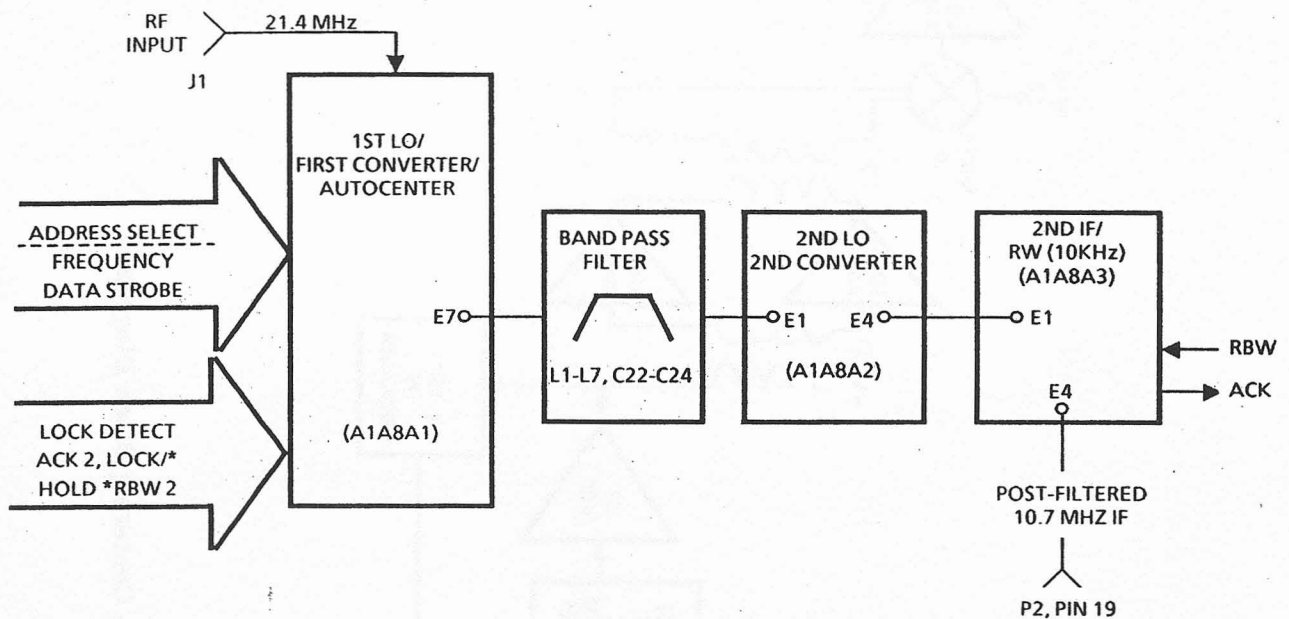

Figure 3-9. Frequency Converter/Sweep Assembly Block Diagram

3.2.6.1 Type 796540-1 First LO/First Converter/Auto Centering Assembly (A1A8A1)

Refer to Figure 6-11 for the Type 796540-1 First LO/First Converter/Auto Centering schematic diagram. The reference designation for the First LO/First Converter/Auto Centering assembly is A1A8A1. Refer to Figure 3-10 for the First Converter/Auto Centering block diagram.

Selected input IF signals from E2 of the Input Filter assembly (A1A7A2) are routed directly from E6 (RF IN) to double balanced mixer U5. The other input to U5 is the synthesized 118.1 MHz. The output from mixer U5 is the 96.7 MHz First IF.

The synthesized frequency is determined by the phase-locked-loop (PLL) frequency synthesizer U8. PLL frequency synthesizer U8 uses a 5 MHz crystal oscillator (Y1) for a reference frequency. Input data (E9-E16) determines the preset division ratio of the two internal dividers and selects the internal latches. This data is used to preset the two internal dividers ($\div A$ and $\div N$) in U8.

The frequency at pin 3 (f_{IN}) is from the voltage controlled oscillator (VCO). Transistor Q1, transmission line DL1, variable capacitance (varicap) diodes CR2-CR5, and the associated components form the VCO. The transmission line oscillator produces the 118.1 MHz (± 2.5 MHz) VCO frequency. The output VCO frequency is amplified by U2 before being applied to divide by 10/11 prescaler U9. From U9, the VCO frequency is applied to PLL frequency synthesizer U8.

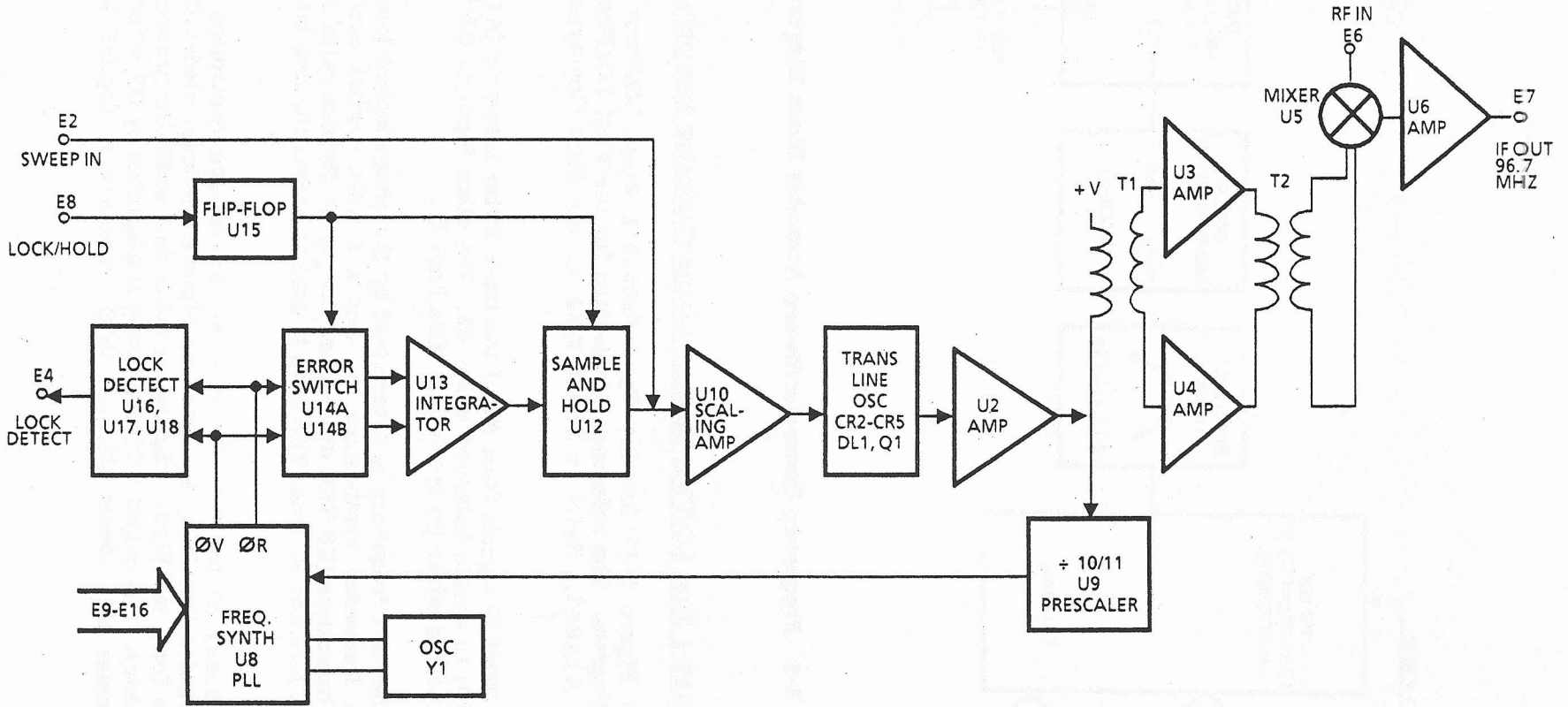

Figure 3-10. First LO/First Converter/Auto Centering Block Diagram

U8 divides the input VCO frequency and compares it with the divided crystal oscillator frequency. When both frequencies are the same, a lock condition exists. During a lock condition, the phase detector outputs (pins 16 and 17) from U8 are essentially High. Applying a logic High level to the lock detector circuit (composed of U16, U17, U18, and the associated components) provides the LOCK DETECT output for the microprocessor. A High at the LOCK DETECT indicates that the frequency is centered. Phase detector outputs from U8 are also directed to the error switch circuit (composed of U14A, U14B, and the associated components). From the error switch, the error signal is routed through integrator U13 to the sample and hold circuit (composed of U12 and C35). The error voltage from U13 is applied to U12, causing capacitor C35 to charge to the value of the error voltage. The output from the sample and hold amplifier (U12) is applied through scaling amplifier U10 to variable capacitance (varicap) diodes CR2-CR5. The error voltage is used to vary the capacitance of the diodes. Changing the capacitance of the varicap diodes tunes the VCO frequency. Changing the VCO frequency reduces the phase detector (U8) output. When the phase detector error output is zero, the VCO is locked on frequency.

Lock/hold flip-flop U15A is used to reset or hold the error voltage output from U12. When the microprocessor receives the LOCK DETECT, a HOLD is sent to U15A. This HOLD causes the error switch (U14A and B) to appear open, allowing C35 to hold the error voltage level that produced the lock. When the VCO is locked, the sweep is started. The signal at SWEEP IN is resistively coupled through U10 and linearizer diodes CR6-CR9 before being applied to the VCO. The VCO signal is amplified by the LO driver amplifier (composed of U2, T1, U3, U4, T2, and the associated components). The LO driver circuit provides a drive level of +17 dBm for the 118.1 MHz (± 2.5 MHz) LO.

U5 mixes the RF input with the LO VCO, producing the 96.7 MHz First IF. The mixer output is amplified by U6 before being directed out E7. The IF OUT from E7 is band-pass filtered (L1-L7 and C19-C24) before being applied to the Second LO/Second Converter (A1A8A2).

3.2.6.2 Type 796541-1 Second LO/Second Converter (A1A8A2)

Refer to Figure 6-12 for the Type 796541-1 schematic diagram. The reference designation for the Second LO/Second Converter is A1A8A2. Refers to Figure 3-11 for the Second LO converter block diagram.

The 96.7 MHz First IF input at E1 is low pass filtered (C7-C9, L2, and L3), attenuated 3 dB, and then applied as one input to mixer U4. The other input to mixer U4 is 86 MHz from the third overtone crystal oscillator. The crystal oscillator (composed of Y1, Q1, L1 and the associated components) produces an 86 MHz signal that is applied to the LO driver. Oscillator outputs are applied to the LO driver circuit (composed of U1, T1, U2, and U3) for amplification before being transformer coupled across T2. From T2, the oscillator signal is attenuated 3 dB (by R13-R15) before being mixed by U4. Mixer U4 produces the 10.7 MHz Second IF. The 10.7 MHz Second IF is directed out E4 to the Second IF/10 kHz RBW subassembly (A1A8A3).

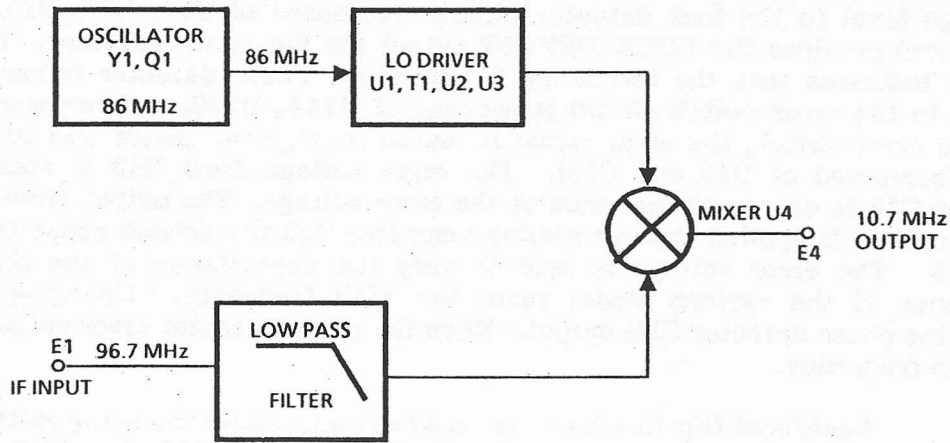

Figure 3-11. Second LO Converter Block Diagram

3.2.6.3 Type 796542-1 Second IF/RBW (A1A8A3)

Refer to Figure 6-13 for the Second IF/RBW (10 kHz) schematic diagram. The reference designation for the Type 796542-1 Second IF/RBW subassembly is A1A8A3. Refer to Figure 3-12 for the Second IF/RBW block diagram.

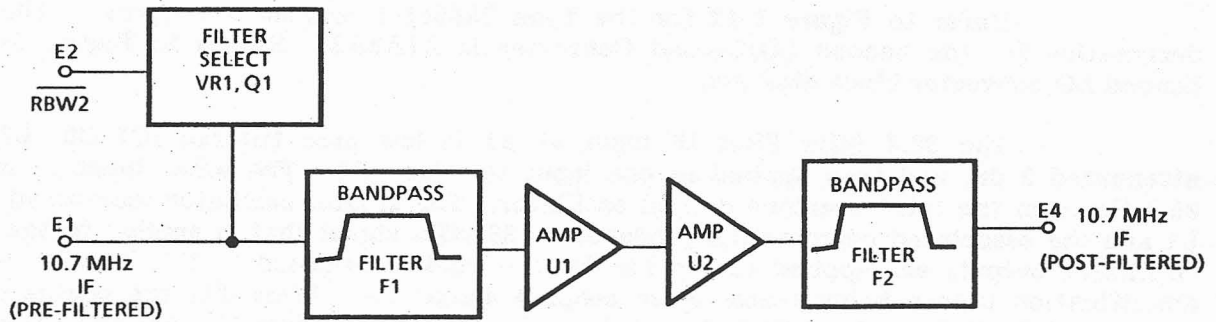

Figure 3-12. Second IF/RBW Block Diagram

The pre-filtered 10.7 MHz Second IF at E1 is attenuated 3 dB before being capacitively coupled across C1. For the pre-filtered 10.7 MHz IF to be filtered, the logic level at E2 (RBW 2) must be Low. Transistor Q1 then conducts forward biasing switching diodes CR1 and CR2 which allows the 10.7 MHz IF to be filtered through bandpass filter FL1 before being amplified by U1 and U2. After amplification, the IF signal is bandpass filtered through FL2 before being coupled to E4. From E4, the post-filtered 10.7 MHz IF is directed to connector P2 pin 19. From P2 pin 19 the IF signal is directed to the optional Second IF A1A9 and to the LOG IF Amplifier/Detector A1A10.

3.2.6.4 Type 796790-1 Second IF/2 kHz RBW (A1A9) (Optional)

Refer to Figure 6-14 for the Second IF/2 kHz RBW schematic diagram. The reference designation for the Type 796790-1 Optional Second IF/RWB 2 kHz subassembly is A1A9. Refer to Figure 3-13 for the optional Second IF/2 kHz RBW block diagram.

The pre-filtered 10.7 MHz IF signal is routed from the Frequency Converter/Sweep Assembly to the Second IF/2 kHz RBW input at E1. The optional Second IF/2 kHz RBW circuits are enabled by a Low logic level at the control signal input (E2). The switch control operational amplifier U1 is configured as a comparator and the Low level input causes its output to go to +15 volts. This positive voltage turns on the transistor amplifier Q1 as soon as the cutoff threshold voltage at the base of transistor Q1 is exceeded. When Q1 is turned on, the amplifiers U2 and U3 are supplied with power and the PIN diodes CR1 and CR2 are forward biased.

Once the Second IF/2 kHz RBW circuits have been activated, the unfiltered IF signal is coupled through PIN diode CR1 to the first amplifier stage U2. The input is also routed through a variable attenuator pad consisting of resistors R18, R19, and R20. This attenuator pad can be adjusted by R19 from approximately 3 dB to 6 dB. Amplifier U2 drives the bandpass filter through a fixed 5 dB pad consisting of resistors R13, R14, and R16. This pad isolates the filter from any mismatch caused by the variable attenuator pad. The signal is amplified by amplifier U3 and coupled through the PIN diode output switch CR2 to the LOG IF Amplifier/Detector (A1A10).

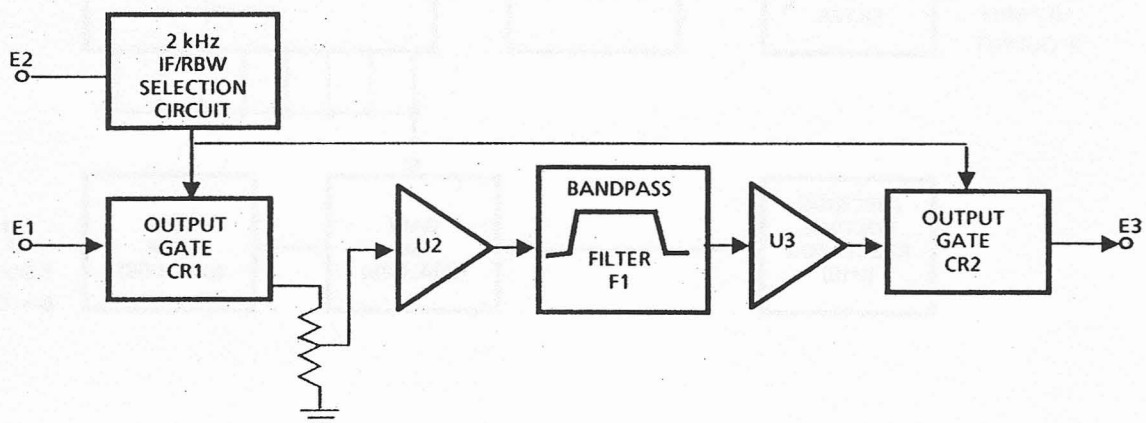

Figure 3-13. Optional Second IF/2 kHz RBW Block Diagram

When the Second IF/2 kHz RBW assembly is not selected, a High logic level on the select line RBW0 causes the output of the comparator U1 to be below the threshold voltage that keeps transistor switch turned off. As a result a negative voltage is applied to the power/bias line for the Second IF/2 kHz RBW circuits. This reverse biasing of the PIN switch diodes ensures that there is minimal interaction with the selected Resolution Bandwidth operation.

3.2.7 TYPE 796577-1 LOG IF AMPLIFIER/DETECTOR (A1A10)

Refer to Figure 6-15 for the LOG IF Amplifier/Detector schematic diagram. The reference designation for the Type 796577-1 LOG IF Amplifier/Detector is A1A10. Refer to Figure 3-14 for the LOG IF/Detector block diagram.

LOG IF Detector A1A10A1 (Type 796505-2) is located on the LOG IF Amplifier Detector assembly (A1A10). The post-filtered 10.7 MHz IF signal enters the LOG IF Detector (A1A10A1) at E1. Refer to Figure 6-16 for the LOG/IF/Detector schematic diagram. The IF signal is low pass filtered before being buffered by Q1 and applied to successive detectors U1-U7. Each successive detector provides approximately 11 dB of gain control before saturating. Combined the detectors provide more than 77 dB of gain range. The RF output of each stage (pin 3) is coupled to the input (pin 6) of the next stage. The detected outputs (pin 4) are tied together and applied to the summer/amplifier circuit (composed of U8, and U9). The output voltage from U9B is present at E7 as the Y OUTPUT. This output voltage is from 0 to approximately 5 Vdc and is determined by the input signal level. The output voltage from the successive detectors is also applied to the linearizer and is directed through U9A. The Y output is routed to the peak detect and dump circuit on the data acquisition assembly (A1A2).

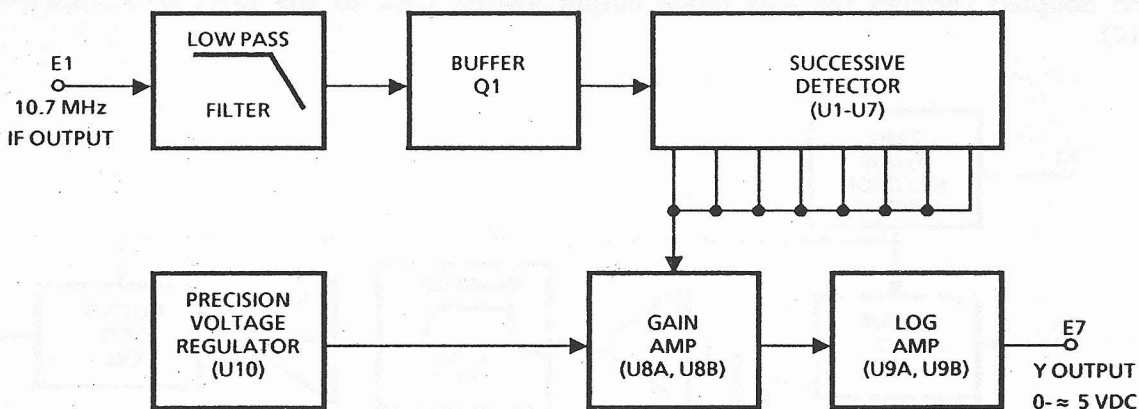

Figure 3-14. LOG IF Detector Block Diagram

3.2.8 TYPE 796538-1 REMOTE INTERFACE BOARD (A1A5) (OPTIONAL)

Refer to **Figure 6-6** for the Remote Interface Board (A1A5) schematic diagram. Refer to **Figure 3-15** for the Remote Interface block diagram.

The Remote Interface Board (A1A5) is an optional unit that provides talk and listen capabilities between the signal monitor and external controlling devices. The data is transferred between the units in a bit-parallel, byte serial form utilizing sixteen interconnecting lines. These lines consist of eight bi-directional data bus lines, three data byte transfer lines and five management lines. Data or address information is transferred between devices utilizing the data bus lines.

The data byte transfer lines indicate: the availability and validity of the information on the data bus lines, if the devices are ready to accept data, and if the data has been accepted. The interface management lines indicate: specify whether the data bus lines are carrying address information, request service, clear the interface or indicate the end of a transfer sequence. The capabilities of the IEEE-488 interface and the command format are described in **paragraph 2.5**.

As shown on the block diagram **Figure 3-15**, the address and data bus as well as the read/write control signal (R/W*) are input from the microprocessor to the General Purpose Interface Bus (GPIB) processor U3 and the address decoder U6, U8, and address switch S1. When the units address is received from the microprocessor or the controller during remote operation, data is transferred to and from the data bus by GPIB transceiver U1. In a similar manner, the management control lines are handled by the GPIB transceiver U4. Through microprocessor to microprocessor communications the signal monitor operation can be controlled and monitored by remote control devices. The remote control interface module includes expansion circuits for future implementation of RS-232C and RS-449 interface capabilities.

3.2.9 TYPE 796539-1 KEYBOARD DISPLAY (A4)

Refer to **Figure 6-20** for the Keyboard Display schematic diagram. The reference designation for the Type 796539-1 Keyboard Display is A4.

Keyboard Display circuitry consists of the key encoder (U5), the alphanumeric displays (U1-U4), the pushbuttons (S1-S13), and the two LEDs (DS1 and DS2).

Pressing one of the front panel pushbuttons (S1-S13) momentarily completes the contact between the X and Y inputs of key encoder U5. When a pushbutton is pressed, encoder U5 forces the DATA AVAL line (connector P1 pin 6) High. With this line High, the microprocessor reads the data at the DATA OUT (connector P1 pins 1-5). The microprocessor uses this data to update the displayed information. Writing new data to the Keyboard Display is accomplished via writing the new data onto the keyboard data bus (KD0-KD6).

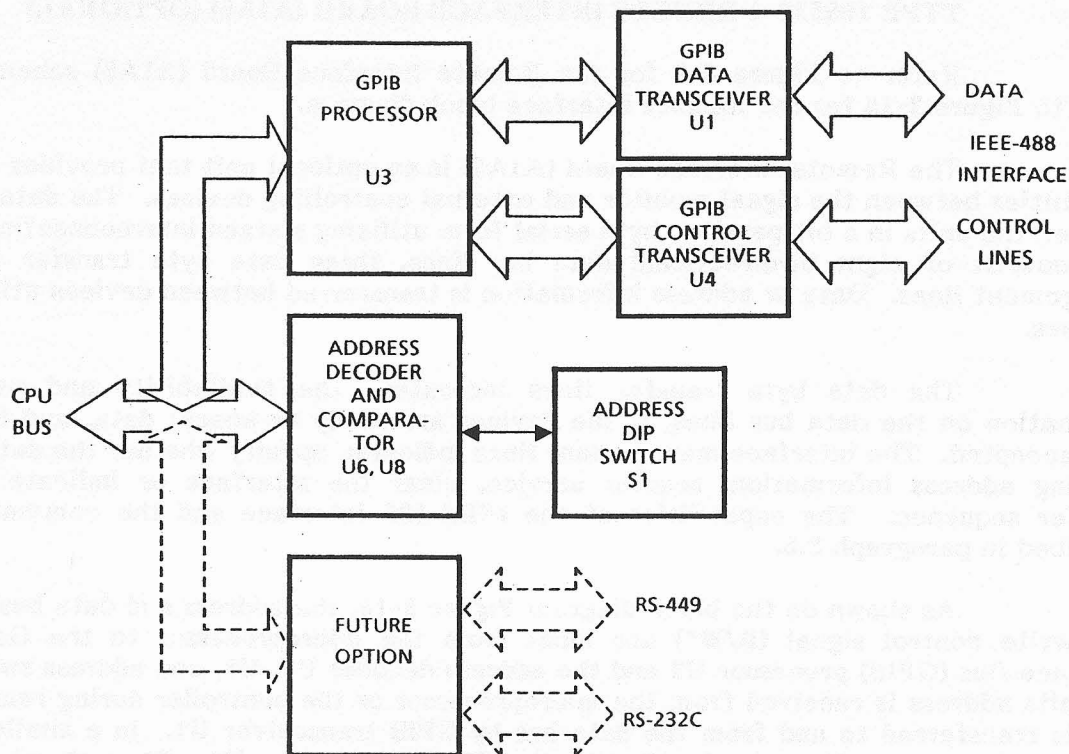

Figure 3-15. Remote Interface Block Diagram

Alphanumeric displays U1-U4 are four character, sixteen-segment displays. Logic levels at KA0 and KA1 determine to which display digit the data is written. When both KA0 and KA1 are Low, the far right digit (DG0) is selected. The following list indicates the digit select (A0 and A1) logic level to select the different display drivers (DG0-DG3).

A0	A1	DG3	DG2	DG1	DG0
L	L	---	---	---	SEL
L	H	---	---	SEL	---
H	L	---	SEL	---	---
H	H	SEL	---	---	---

Microprocessor control of the CLEAR, CUE, CURSR, CE, and WR lines allows the microprocessor to update data in the selected display digit. Using the digit select lines and the control lines, data on the keyboard data bus lines updates the front panel display. DISP1-DISP4 are used to select the display driver selected for updating. When the BLANK line is Low, the front panel display is blanked.

LED indicator DS1 is used to indicate the control status (Local or Remote) of the signal monitor. When DS1 is illuminated the signal monitor is in remote control. This allows a suitable controller to remotely operate the signal monitor. When this LED is extinguished, the signal monitor is in local control. This allows the front panel pushbuttons to control the signal monitor operation.

LED indicator DS2 illuminates to indicate the SHIFT function has been selected for the front panel pushbuttons. Refer to **Section II** for an explanation of the SHIFT operation. Pressing the SHIFT key illuminates the SHIFT LED and enables the Shift operation.

3.2.10 TYPE 796782-1 HIGH VOLTAGE POWER SUPPLY/VIDEO (A2)

Refer to **Figure 6-17** for the High Voltage Power Supply/Video schematic diagram. The reference designation for the High Voltage Power Supply/Video assembly is A2.

This assembly contains Cathode Ray Tube (CRT) V1 and the High Volt Power Supply/Deflection Amplifier (A2A1). The CRT provides the video display for the sweep trace(s). The High Volt Power Supply/Deflection Amplifier provides the voltages and controls for producing the video display.

3.2.10.1 Type 796545-1 High Voltage Power Supply/Deflection Amplifier (A2A1)

Refer to **Figure 6-18** for the High Voltage Power Supply/Deflection Amplifier schematic diagram. The reference designation for the High Voltage Power Supply/Deflection Amplifier assembly is A2A1. Refer to **Figure 3-16** for the High Voltage Power Supply block diagram.

This assembly produces the voltages necessary to provide a display on the CRT. Voltages for the CRT are produced by the 2 kV circuit (composed of U4, Q1, Q2, T1, and CR3-CR6). The -15 Vdc is inductively coupled via L1 to pulse width modulator U4 and to the source of HEXFETs Q1 and Q2. U4 is used to generate non-overlapping in-phase and out-of-phase squarewaves to drive FETs Q1 and Q2. The squarewaves are used to control the conduction of the FETs.

U5B, Q3, Q4, and their associated components form a linear regulator. The regulator compares a -5 Vdc sample from the -2 kV output with the -5 Vdc reference. The -5 Vdc reference is applied through R7 to the inverting input of U5B. The high voltage reference sample taken from the tap of R20 (approximately -5 Vdc) is applied to the noninverting input of U5B. U5B compares the two input voltages and produces an output correction voltage. This voltage is coupled via R8 to the base of transistor Q3. The collector output of Q3 is applied directly to the base of Q4.

The output voltage from U5B drives Q3, which in turn drives Q4. The output of Q4 varies the voltage at pin 5 of the primary of transformer T1. It is this voltage that regulates the -2 kV.

The same high voltage sample applied to U5B is also applied to U3A and U3B. Buffered -5 Vdc from U3B is applied across R79 to U3A. U3A inverts the high voltage sample to a +5 Vdc. This voltage is used for the HV SAMPLE used during BITE testing.

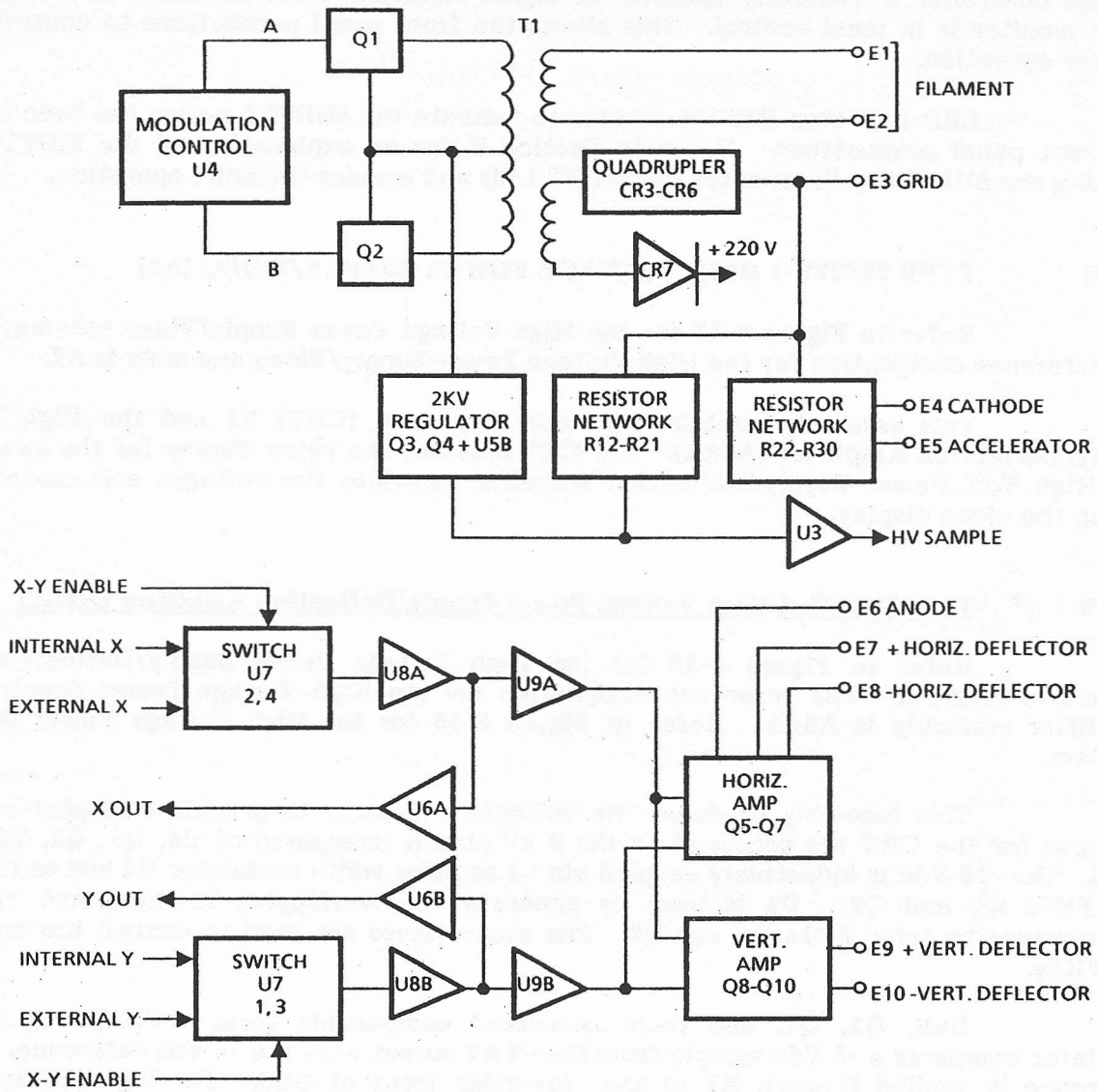

Figure 3-16. High Voltage Power Supply Block Diagram

The high voltage sample at amplifier U3B is decreased by a factor of 1/2 through U3A (a gain of -.5). The 2.5 V at E11 is directed to the Input/Output module (A1A4) as the reference voltage for the HV test voltage.

The 500 V at pin 1 of the secondary of T1 is quadrupled (x4) via diodes CR3-CR6 and capacitors C15 and C16. The resultant -2,000 Vdc is resistively coupled via R11 out E3 to the GRID of the CRT. The same voltage applied to E3 is reduced through voltage dividers to provide the high voltage sample (R12-R21), the CATHODE voltage, and ACCELERATION voltage (R22-R30) at E4 and E5 respectively. Diodes CR1 and CR2 fullwave rectify the voltage across E14 and E16, producing the 6.3 Vdc FILAMENT voltage. Diode CR7 halfwave rectifies the voltage at E2 producing +220 Vdc for biasing the deflection driver circuits.

Depending on the switch setting of U7, an external XY source is used or, signals from the DRD module (A1A3) are used to produce the X and Y deflections for the CRT. The selected X or Y source from connector P1 is directed through the closed switch contacts of U7 to amplifier U8. The logic level at connector P1 pin 14 determines whether the external or internal XY source is selected. The X signal is amplified by U8A and resistively coupled to U9A and U6A. From U9A the signal is applied to the base of transistor Q5. The output of U6A is applied to the rear panel X OUTPUT. The Y signal from U8B is resistively coupled to U9B and U6B. The amplified signal from U9B is applied to the base of Q8. From U6B, the signal is applied to the rear panel Y OUTPUT.

X and Y signals from U9A and U9B, respectively, are applied to differential amplifiers Q5 and Q6 (for the X signal) and Q8 and Q9 (for the Y signal). Along with constant current amplifiers Q7 and Q10, the differential amplifiers provide approximately +120V output for the horizontal deflectors and the vertical deflectors for the CRT.

3.2.11 TYPE 796771-1 LOW VOLTAGE POWER SUPPLY (A3)

Refer to **Figure 6-19** for the Low Voltage Power Supply schematic diagram. The reference designation for the DC Power Supply is A3. Refer to **Figure 3-17** for the DC Power Supply block diagram.

The Low Voltage Power Supply is composed of a full-wave bridge rectifier (U1), a half-wave rectifier (CR1, CR2) and four voltage regulators (U2-U5) and supplies +15V, -15V, +8V, and +5V operating voltages to both the analog and digital circuits of the Signal Monitor.

Input AC power (50-400 Hz) is applied through line filter F11, POWER switch S1, Voltage Selector Switch S2, and power transformer T1. Switch S2 is set to either 115 Vac or 230 Vac position depending on the line voltage to be used and adapts the connects to the primary of the step-down power transformer T1.

One of the two secondary windings of transformer T1 supplies the ac voltage to the full-wave bridge rectifier U1. Both negative and positive rectified output voltages are provided by U1. The positive voltage is filtered by capacitor C8 and input to the +15 volt regulator U2. The regulated +15 voltage is routed to the signal monitor circuits through inductor L1 from pin 5 of power supply connector P1.

The negative output from bridge rectifier U2 is filtered by capacitor C9 and input to the -15 volt regulator U3. The regulated -15 voltage is routed to the signal monitor circuits through inductor L2 from pin 1 of power supply connector P1.

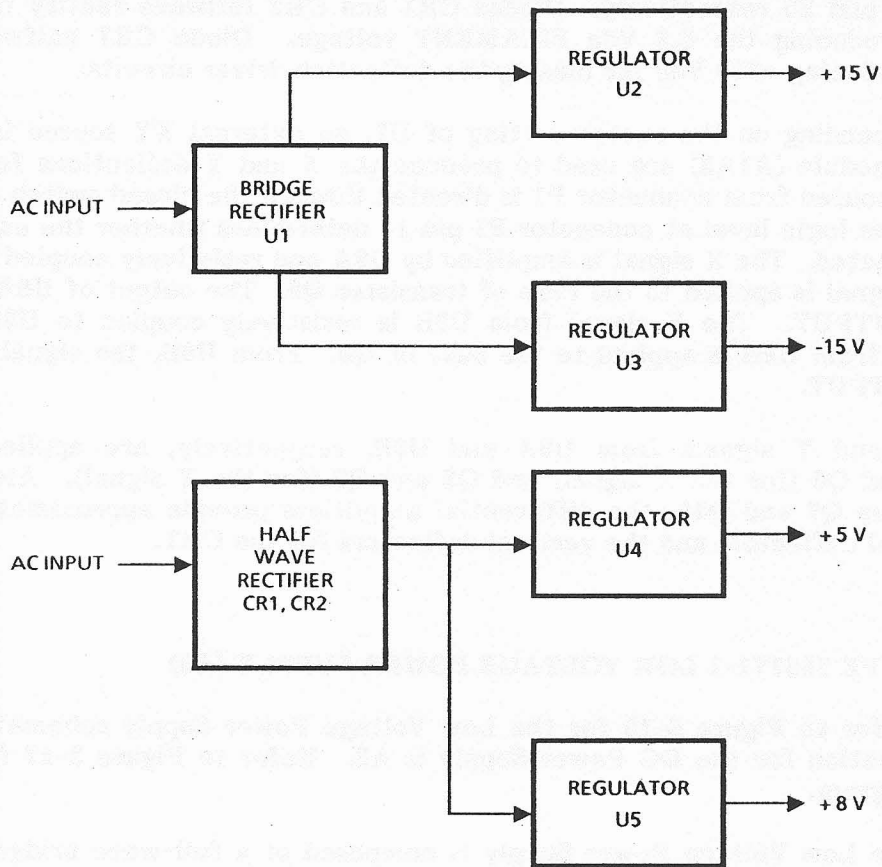

Figure 3-17. Switching Power Supply Block Diagram

The other secondary winding of transformer T1 supplies the ac voltage to the half-wave rectifiers CR1 and CR2. The positive voltage from the rectifier is filtered by capacitors C10 and C11 and applied to voltage regulators U4 and U5. The regulated +5 volt output from regulator U4 is routed through inductor L3 and is available at pin 3 of connector P1.

The regulated +8 volt output from regulator U5 is routed through inductor L4 and is available at pin 4 of connector P1.

SECTION IV
MAINTENANCE

SECTION IV
MAINTENANCE

4.1 GENERAL

The WJ-9205 Signal Monitor has been designed to operate for extended periods of time with a minimum of routine maintenance. Cleaning, inspection and performance tests should be performed at regular intervals, consistent with the facility's normal maintenance scheduling and after repairs have been completed.

4.2 CLEANING AND LUBRICATION

The unit should be kept free of dust, moisture, grease, and other foreign material to ensure trouble-free operation. Low pressure air can be used, if available, to remove accumulated dust from the interior of the unit. A clean, dry cloth or soft bristled brush may also be used to remove the accumulation of dust. No lubrication of this unit is required.

4.3 INSPECTION FOR DAMAGE OR WEAR

Many existing or potential troubles can be detected by making a thorough visual inspection of the unit. For this reason, as a first step, a complete visual inspection should be made whenever the unit is inoperative. First, inspect mechanical parts, such as pin connectors and interconnecting cables for looseness, wear, and signs of deterioration. Inspect plug-in modules and subassemblies to ensure that they are properly installed, in their appropriate connector slot, and making good electrical contact. Finally, electrical components that show visible signs of deterioration, such as overheating, discoloration, or "sweating" should be carefully checked for proper operation. In addition, a thorough inspection of the associated circuitry should be made to verify proper operation. Often times, damage due to overheating is the result of other, less apparent problems in the circuit.

4.4 TEST EQUIPMENT REQUIRED

The test equipment listed in Table 4-1, or equivalent equipment is required to perform the following troubleshooting procedures, performance tests, and alignment procedures.

Table 4-1. Test Equipment Required

Equipment	Description	Type
Autotransformer	Variable	W5MT3W General Radio
Digital Voltmeter	High Impedance	8050A Fluke
Signal Generator	20 Hz-1024 MHz	8640B Hewlett-Packard
Spectrum Analyzer	100 Hz-1.5 GHz	8568B Hewlett-Packard
Oscilloscope	100 MHz Dual Trace	465B Tektronix
AC Power Source	45 Hz-10 kHz	400V Elgar
Volt/Power Meter	Volt/Ammeter	501A Elgar
Signal Monitor	21.4 MHz IF Out	WJ-9205
Computer Controller	82937A IEEE-488	85 Hewlett-Packard
Test Tape	Remote Control Tape	RCS-30026 WJ

4.5 **TROUBLESHOOTING AND FAULT ISOLATION PROCEDURES**

Troubleshooting of this unit can be performed by placing the unit in its normal operating mode and observing its operation during various operating conditions. To eliminate the possibility of external conditions causing the suspected problem, use the equipment listed in **Table 4-1** to inject the required signal and monitor the result.

The following performance tests, and the Troubleshooting Table (**Table 4-2**) are provided as an aid for localizing the cause of a malfunction to a particular subassembly or module within the unit. Refer to the block diagrams (in **Section III**) and the schematic diagrams (in **Section VI**) to aid in the troubleshooting.

NOTE

To prevent possible damage to the unit circuitry, turn power off before removing or installing any subassembly or module.

Table 4-2. WJ-9205 Troubleshooting Table

Symptom	Probable Cause	Corrective Action
Unit totally inoperative. No display or output.	Fuse F1 blown	Locate and correct cause of blown fuse. Replace blown fuse.
	Defective power switch	Verify proper operation of switch S1. Replace if defective.
	Failed Low Voltage Power Supply (A3)	Refer to paragraph 4.6.1.
	Defective I/O module (A1A4)	Refer to paragraph 4.6.6.
Display dim	Set for 230 Vac operation with 115/Vac applied to the unit	Set voltage select switch (S2) for proper line voltage.
No display on CRT	Faulty Sweep module (A1A8)	Verify proper operation of A2A1.
	Defective High Voltage Power Supply (A2)	Verify proper operation A2.
	Faulty CRT	Verify proper CRT operation.
	All three Inputs are OFF	Select the desired input.
Only a dot displayed on CRT	X-Y Mode selected	Connect external monitor. Select a receiver input.

Table 4-2. WJ-9205 Troubleshooting Table (Continued)

Symptom	Probable Cause	Corrective Action
Signal amplitude is nonlinear	Faulty LOG/IF Det (A1A10)	Verify proper LOG/IF operation. Refer to paragraph 4.6.7.
Unable to select different inputs	Defective Input Control (A1A7)	Refer to paragraph 4.6.6.
Attenuation inoperative	Defective Input Control (A1A7)	Refer to paragraph 4.6.8.
Extra decimal points on display	Failed Bite	Determine which test failed by pressing SHIFT key and then the 2 key, observe front panel display.
Front panel push-buttons inoperative	Defective keypad or faulty Keyboard Display module (A4)	Verify operation of keyboard. Refer to paragraph 4.6.4.
	In Remote Control mode	Verify front panel LED labeled REM is extinguished.
Lights but does not respond (latched up)	Faulty Data in Memory	Turn power on again and press the B key during the power up sequence.

4.6 PERFORMANCE TESTS

The following performance test procedures may be used for periodic performance testing, as an aid in troubleshooting, or as a unit performance test after repairs have been completed. These procedures should be performed only by skilled technicians familiar with the unit and with the tests being performed.

4.6.1 LOW VOLTAGE POWER SUPPLY PERFORMANCE TEST

1. Prior to connecting power to the signal monitor, ensure switch S2 is set to the 115 Vac position.
2. Connect the test equipment as illustrated in Figure 4-1 and set the auto transformer to the minimum output voltage position.
3. Turn the signal monitor power switch to the on position and slowly increase the voltage on the auto transformer toward 115 Vac. Ensure the power consumption does not exceed 45 watts at 115 Vac (less than 500 mA).

4. With a line voltage setting of 115 Vac on the auto transformer, measure the Low Voltage Power Supply voltages with the digital voltmeter. Refer to Table 4-3 for the test point, the voltage, and the specified tolerance.

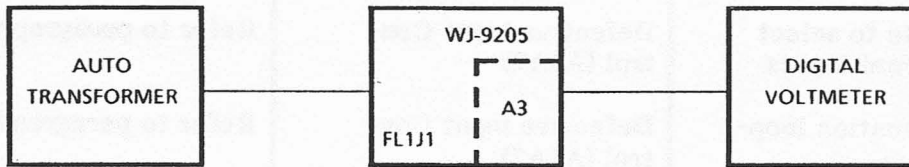

Figure 4-1. Power Supply Performance Test, Equipment Connections

Table 4-3. Low Voltage Power Supply Voltages

Test Point	Supply	Voltage (Tolerance)
A3E5	+15 Vdc	+15 (±0.1 Vdc)
A3E1	-15 Vdc	-15.4 (±1.0 Vdc)
A3E4	+8 Vdc	+8.1 (±0.3 Vdc)
A3E3	+5 Vdc	+5.0 (±0.25 Vdc)

5. Slowly decrease the auto transformer output voltage until the front panel display fails to operate properly. (A span of .5M begins to break up and become unstable.) Verify the auto transformer output voltage is less than or equal to 103.5 Vac. Various BITE error messages are visible on the front panel display.
6. Disconnect the test equipment.

4.6.2 HIGH VOLTAGE POWER SUPPLY/DEFLECTION AMP PERFORMANCE TEST

1. Verify the presence of a sweep trace on the CRT. The displayed trace on the CRT indicates that the High voltage power supply is functioning.

2. Rotate the front panel INTENSITY control knob and verify that at minimum intensity (max CCW) the trace is not visible and at the maximum intensity (max CW) the trace is of adequate intensity and does not expand or lose its focus.

4.6.3 MICROPROCESSOR PERFORMANCE TEST

Microprocessor operation is indicated by the proper functioning of the signal monitor.

4.6.4 KEYBOARD AND DISPLAY PERFORMANCE TEST

1. Apply 115 Vac line voltage to the signal monitor FL1J1 and turn the signal monitor on.
2. Observe the front panel Alphanumeric display.
 - a. Verify that all segments of each LED is illuminated and are approximately the same brightness.
 - b. Verify the front panel display temporarily indicates the unit type and software version as: **WJ 9205 - X.X.X**
 - c. Press each of the keys on the front panel to verify the mechanical and electrical operation of the key and its associated function, as listed in Table 4-4.

Table 4-4. Pushbutton Performance Verification

Function	Range	Sequence
TRACE INPUT	1-3 OFF-XY	1, 2, 3 OFF, RX1, RX2, RX3, M-Z, X-Y
SPAN	000-5M	000, 50k, .1M, .2M, .5M, 1.M, 2.M, 5.M
RBW	10 KHz	10 KHz, OPTION NOT INST (if option is not installed)
ATTEN	0-70	0, 10, 20, 30, 40, 50, 60, 70

- d. Set the signal monitor operating parameters as follows:

TRACE 1
INPUT M-Z
TRACE 2 OFF
TRACE 3 OFF

- e. Press the SHIFT key and then the 1 key. Observe that the calibration ramp is displayed on the CRT. Observe that the ramps are relatively linear, continuous, and without gaps in the trace.
- f. Press the INPUT key until 1 is displayed on the display. Press the STORE key.
- g. Press the INPUT key until M-1 is displayed on the front panel. Verify that the test ramp is not stored in memory.
- h. Set the trace parameters as follows:

```
TRACE 1
INPUT RX1
SPAN .1M
ATTEN 10
```

```
TRACE 2
INPUT RX2
SPAN .5M
ATTEN 30
```

```
TRACE 3
INPUT RX3
SPAN 2M
ATTEN 50
```

- i. Press the SHIFT key and the PRESET key to store the set parameters in memory.
- j. Select each of the three traces again and set them all to OFF.
- k. Press the PRESET key and verify that the parameters set in Step h are displayed for each TRACE.

4.6.5

SWEEP WIDTH AND CENTERING PERFORMANCE TEST

- 1. Connect the test equipment as illustrated in Figure 4-2. Set the signal generator for a 21.4 MHz, -90 dBm, CW output.
- 2. Set the signal generator as follows:

```
TRACE 1 (TRACE 2 and 3 OFF)
INPUT RX1
SPAN 50K
ATTEN 0
```

- 3. Observe the displayed trace on the CRT. Verify that it is symmetrical and centered on the SM display.

4. Tune the signal generator frequency until the displayed response is centered over the lowest frequency graduation on the display graticule. Note the signal generator frequency.
5. Tune the signal generator frequency until the displayed response is centered over the highest frequency graduation on the display graticule. Note the frequency of the signal generator.
6. Repeat Steps 4 and 5 for each signal monitor SPAN. Refer to Table 4-5 for the SPAN and the associated sweep width. The tolerance for each SPAN is 10% of the selected SPAN.

Table 4-5. SPAN and Sweep Width

SPAN	Low Frequency	High Frequency	Tolerance
.05M	21.375 MHz	21.425 MHz	±10%
.1M	21.350 MHz	21.430 MHz	±10%
.2M	21.300 MHz	21.500 MHz	±10%
.5M	21.150 MHz	21.600 MHz	±10%
1.M	20.900 MHz	21.900 MHz	±10%
2.M	20.400 MHz	22.400 MHz	±10%
5.M	18.900 MHz	23.900 MHz	±10%

4.6.6

INPUT/OUTPUT CONTROL PERFORMANCE TEST

1. Connect the equipment as illustrated by the solid line in Figure 4-2. Set the signal generator for a 21.4 MHz, -40 dBm, CW output signal.

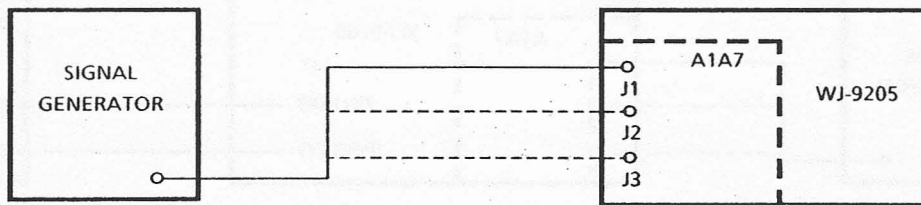

Figure 4-2. Input/Output Performance Test, Equipment Connections

2. Select TRACE 1 and INPUT 1 on the signal monitor and observe the level displayed on the CRT.
3. Move the signal generator output to A7J2 and select approximately the same level as observed in Step 2.
4. Move the signal generator output to A7J3 and select INPUT 3. Verify that the observed level is approximately the same level as observed for Steps 2 and 3.
5. Reconnect the signal generator output to A7J1. Select INPUTS 2 and 3 while observing the displayed trace. Verify that feed-through from INPUT 1 is visible on the other displayed traces.

4.6.7 LOG/IF DETECTOR PERFORMANCE TEST

1. Set the signal monitor controls as follows:

TRACE 1
 INPUT 1
 SPAN 5.M
 ATTEN 0

2. Connect the equipment as illustrated by the solid lines in Figure 4-3. Set the oscilloscope inputs for 0.1 volts/division and for X-Y operation.
3. Set the signal generator output to 21.4 MHz and adjust the output level until the peak of the displayed signal is at the top graduation on the CRT display. Note the signal generator output level.

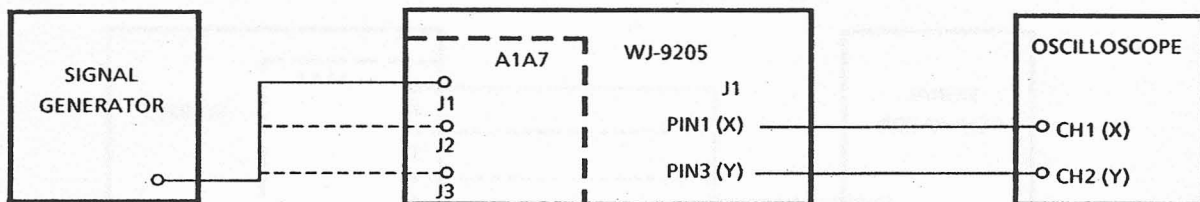

Figure 4-3. LOG/IF Detector Performance Test, Equipment Connections

4. Tune the signal generator from 18.9 MHz to 23.9 MHz while observing the oscilloscope position of the highest and lowest variations.
5. Retune the signal generator to the position of the greatest peak deviation, then tune the signal generator to the position of the greatest negative deviation.
6. Adjust the signal generator output level to move the minimum deviation to the same level as the greatest peak deviation. The difference between the two levels should not exceed 2 dB.
7. Disconnect the oscilloscope X-Y connection from J1 of the signal monitor.
8. Reset the signal monitor SPAN to 2.M. Set the signal generator output level to produce a response at the top graduation on the CRT. The level should be -27 dBm (± 2 dB). The following list indicates the signal generator output level and the graduation mark. Reduce the signal generator output until the display is at the next lower graduation mark.

<u>Graduation</u>	<u>Output Level (± 2 dB)</u>
Top	-27 dBm
2nd	-37 dBm
3rd	-47 dBm
4th	-57 dBm
5th	-67 dBm
6th	-77 dBm
7th	-87 dBm
8th	-97 dBm

9. Reduce the signal generator output level until the display on the CRT is barely visible (minimum amplitude). Verify the signal generator output is at least -100 dBm.

4.6.8

INPUT ATTENUATOR PERFORMANCE TEST

1. Connect the test equipment as illustrated in Figure 4-2. Set the signal generator for 21.4 MHz, CW, with an output level to produce a signal on the CRT at the top graduation with 0 dB attenuation.
2. Use the ATTN increment key to select 10 dB of attenuation. Verify the display on the CRT has decreased approximately one graduation mark.
3. Repeatedly increase the amount of signal monitor attenuation, while observing the CRT display. For each 10 dB increase in attenuation, the display amplitude should drop approximately one graduation.

4.6.9 SECOND IF/2 kHz RBW (A1A9) PERFORMANCE TEST (OPTIONAL)

1. Connect the test equipment as shown in **Figure 4-8**.
2. Set the signal monitor to the parameters listed in **Table 4-6**.
3. Set the signal generator to provide a -50 dBm, CW signal at 21.4 MHz.
4. Select the optional resolution bandwidth from the signal monitor front panel.
5. Verify that the IF filter response has narrowed to 2 kHz and that the level is within 1 dBm of that for the 10 kHz RBW.
6. Tune the signal generator down in frequency and verify that the signal level drops -3 dB.
7. Tune the signal generator up in frequency and verify that the signal level drops -3 dB.

4.6.10 REMOTE INTERFACE (A1A5) PERFORMANCE TEST (OPTIONAL)**NOTE**

The test tape program used for this test addresses the Signal Monitor at IEEE-488 remote address of 26. Refer to **Section 2** and set the address to 26.

1. Connect the cable from the HP-85 computer controller to the remote interface connector J5 on the rear panel of the Signal monitor.
2. Load the file "9205SM" from the test tape RCS-30026. On the HP-85, press RUN.
3. Follow the prompts displayed on the computer controller CRT, and verify that the Signal Monitor operates accordingly.

4.7 ALIGNMENT PROCEDURES

The following alignment procedures should be performed only after the signal monitor failed a performance test or after a module has been repaired or replaced.

WARNING

Exercise extreme care when aligning this unit with the protective covers removed. Potentially lethal voltages are used in this unit.

4.7.1 MICROPROCESSOR (A1A1) ALIGNMENT

1. Locate adjustment R7 and rotate fully counterclockwise (CCW).
2. Observe the signal monitor CRT display and verify that it is blanked.
3. Slowly rotate R7 clockwise (CW) until the signal monitor resumes normal operation, indicated by an audible tone and the power-up display sequence being performed.
4. Rotate R7 one-eighth (1/8) of a turn in the same direction (CW).

4.7.2 DRD/TIMING CONTROLLER (A1A3) ALIGNMENT

1. Set the WJ-9205 Signal Monitor to the parameters listed in Table 4-6.

Table 4-6. WJ-9205 Signal Monitor Alignment Settings

Parameter	Setting
TRACE	1 (Selected) 2 and 3 OFF
INPUT	RX1
SPAN	50K
RBW	10K
ATTEN	0

2. Connect the test equipment as illustrated in Figure 4-4 and place the A1A3 assembly on its extender board.
3. Set the signal generator to 21.4 MHz with a -50 dBm CW output level.

4. Set the oscilloscope vertical input for DC coupling and a sensitivity of 1 VOLT/DIV.
5. Adjust R7 for a centered, symmetrical sweep as displayed on the CRT.

NOTE

To properly align the DRD/Timing Control assembly, the High Voltage Power Supply/Deflection Amplifier (A2A1) must first be properly aligned.

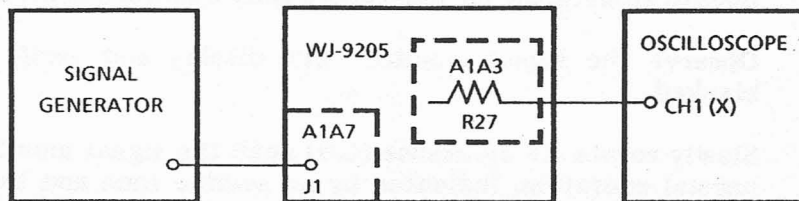

Figure 4-4. DRD/Timing Control Alignment, Equipment Connections

4.7.3 HIGH VOLTAGE POWER SUPPLY (A2) ALIGNMENT

CAUTION

Due to potentially lethal voltages contained on this assembly, extreme caution is necessary when aligning this assembly. Use only the insulated alignment tool when aligning this assembly.

1. Set the signal monitor to the parameters listed in Table 4-6. Refer to Figure 4-5 for a typical test waveform display.
2. Press the SHIFT/1 pushbutton combination to display the sawtooth test pattern on the CRT.
3. Set the INPUT to M-Z and press the STORE pushbutton to store the test pattern in memory.
4. Adjust R25 and R50 for a clear, sharp waveform trace on the CRT display.

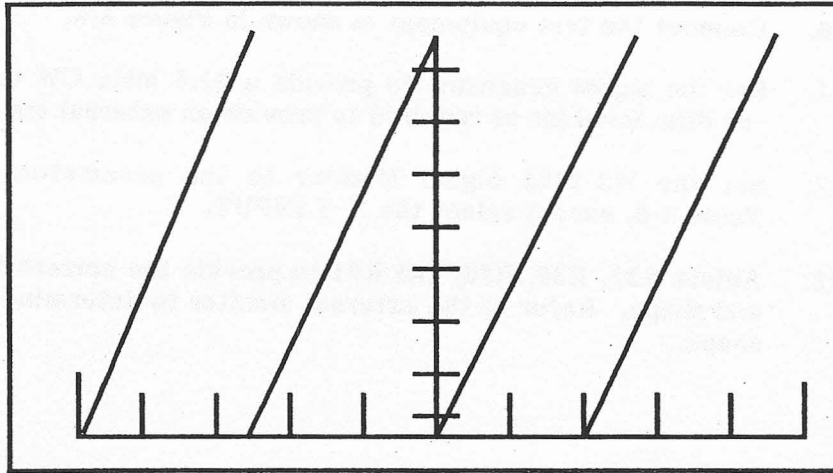

Figure 4-5. Typical Test Waveform

5. Adjust R45 to center the sawtooth transition (between the 2nd and 3rd ramp) at the center of the CRT display (on the vertical graticule).
6. Adjust R43 to produce a slight overscan at either end of the CRT trace. When properly adjusted, the first sawtooth ramp begins slightly to the left of the first horizontal graticule marker and the end of the last ramp extends slightly to the right of the last horizontal graticule marker.
7. Adjust R74 until the start of the sawtooth ramps is at the baseline (the horizontal graticule line).
8. Adjust R64 until the top of the second sawtooth ramp is at the very top of the vertical graticule.
9. Adjust R70 and R80 to rotate the CRT vertical and horizontal axes for a level and square test pattern display. When properly adjusted, all of the ramp waveforms begin at the horizontal graticule line and are centered on the CRT display.

NOTE

The high voltage adjustment (R20) is a factory adjustment and is set correctly during alignment.

Alignment steps 10 to 13 are performed when an external monitor (WJ-9205, WJ-9206 or a similar unit) is connected to rear panel connector J1.

10. Connect the test equipment as shown in **Figure 4-6**.
11. Set the signal generator to provide a 21.4 MHz CW output at a -50 dBm level (or as required to provide an external trace).
12. Set the WJ-9205 Signal Monitor to the parameters listed in **Table 4-6**, except select the X-Y INPUT.
13. Adjust R37, R39, R56, and R61 to provide the correct image size and shape. Refer to the external monitor to determine the signal shape.

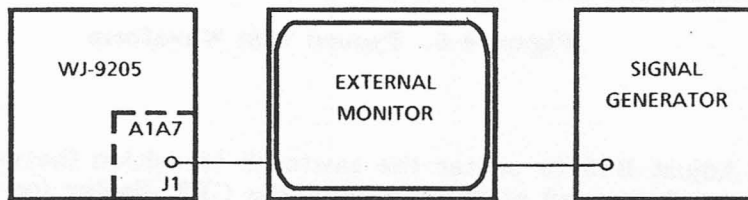

Figure 4-6. X-Y Alignment, Equipment Connections

4.7.4

FREQUENCY CONVERTER (A1A8) ALIGNMENT

1. Set the signal monitor to the parameters listed in **Table 4-6**, remove the assembly covers, and place the A1A8 assembly on the proper extender board.
2. Connect the test equipment as illustrated in **Figure 4-7**.
3. Set the signal generator to provide a -50 dBm CW signal at 21.4 MHz.
4. Observe the signal displayed on the CRT while adjusting C19, C20, and C21 to produce the maximum signal amplitude with the best symmetrical shape.

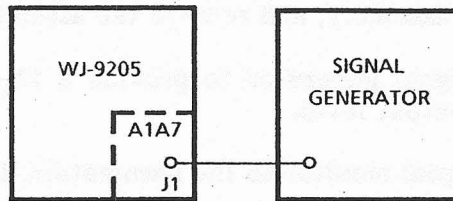

Figure 4-7. Converter/LOG Detector Alignment, Equipment Connections

4.7.4.1 Second LO/Second Converter (A1A8A2) Alignment

1. Connect the test equipment as shown in **Figure 4-7**.
2. Remove the covers from the A1A8 assembly and place the assembly on the extender board for alignment.
3. While observing the CRT display, rotate L1 through its tuning range. Note the inductor tuning position range when the CRT display is not blanked.
4. Set L1 to the midpoint of the adjustment range that produces a display on the CRT.

4.7.4.2 Second IF/RBW (A1A8A3) Alignment

1. Connect the test equipment as shown in **Figure 4-7**.
2. Remove the covers from the A1A8 module and place the module on its extender board.
3. Set the signal monitor to the parameters listed in **Table 4-6**.
4. Set the signal generator to provide a -50 dBm, CW signal at 21.4 MHz.
5. Adjust L3, L4, L7, and L8 for a smooth filter waveform response. **Note:** the waveform may not necessarily be centered on the signal monitor display.

4.7.4.3 First LO/First Converter/Auto Centering (A1A8A1)

1. Connect the test equipment as illustrated in **Figure 4-7**, extend the A1A8 assembly, and remove the assembly covers.
2. Set the signal generator to provide a 21.4 MHz CW signal at a -50 dBm output level.
3. Set the signal monitor to the parameters listed in **Table 4-6**.
4. Adjust C12 to center the signal on the CRT display (at the vertical graticule).
5. Connect an oscilloscope probe to pin 5 of U12 (A1A8A1) and adjust C13 for a 0 Vdc indication on the oscilloscope.
6. Set the signal monitor for a SPAN of 5 MHz.
7. Set the signal generator to provide an 18.9 MHz -80 dBm CW signal.
8. Set the signal monitor to the parameters listed in **Table 4-6**, except select the 5M SPAN.
9. Adjust R44 to align the signal response with the last horizontal graticule marker. (The signal may be on the left or the right, depending on the jumperwire selection on DRD/Timing Controller A1A3.)
10. Tune the signal generator to 23.9 MHz.
11. Observe that the signal is at the opposite end of the displayed trace.
12. Adjust R44 to reduce the difference between the marker position and the last graticule marker by one-half.
13. Repeat steps 7 through 12 until the interaction between the signal position and the end markers is minimum, producing a calibrated 5 MHz display.

4.7.5 LOG IF AMP/DETECTOR (A1A10) ALIGNMENT

1. With no equipment connected to the signal monitor, set the signal monitor to the parameters listed in **Table 4-6**.
2. Adjust R34 until noise starts to become visible on the horizontal trace.
3. Connect the test equipment as illustrated in **Figure 4-7**.

4. Set the signal generator to produce a -27 dBm, 21.4 MHz, CW signal.
5. Adjust R30 to set the signal peak at the top vertical marker.
6. Set the signal generator output level to -97 dBm.
7. Adjust L6 and L8 to produce the greatest signal amplitude.
8. Adjust R2 until the signal peak is at the eighth (bottom) vertical graticule marker.
9. Set the signal generator output level at -27 dBm and readjust R30 to set the signal peak at the top marker again.
10. Repeat steps 4 through 9 until the signal amplitude varies from the top marker (for a -27 dBm input) to the bottom marker (for a -97 dBm input).

SECTION V

REPLACEMENT PARTS LIST

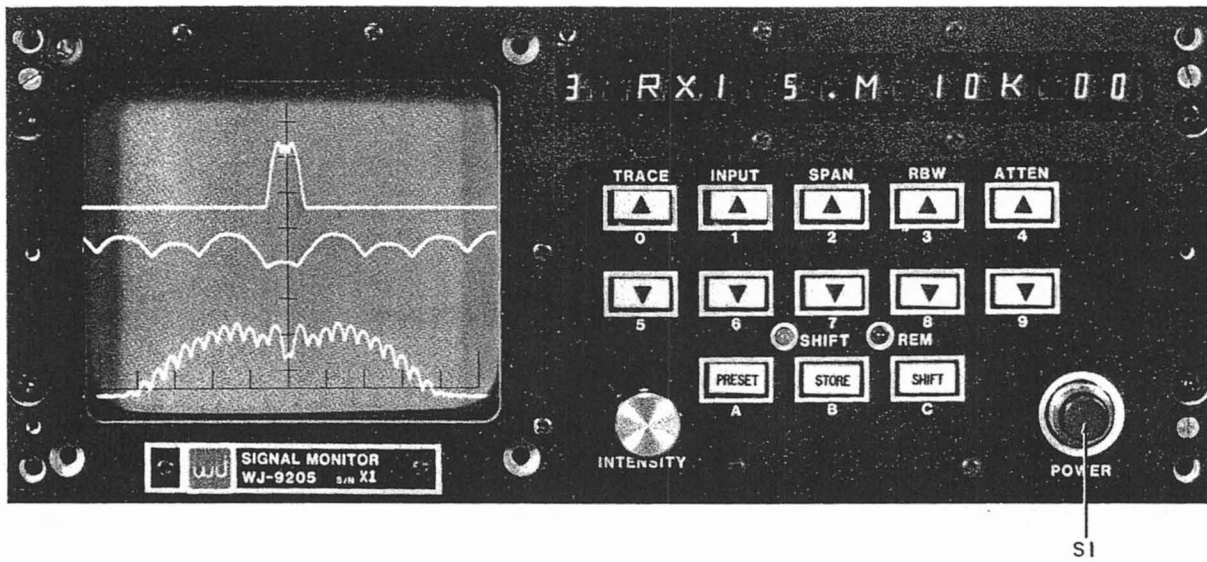

Figure 5-1. WJ-9205 Signal Monitor, Front View

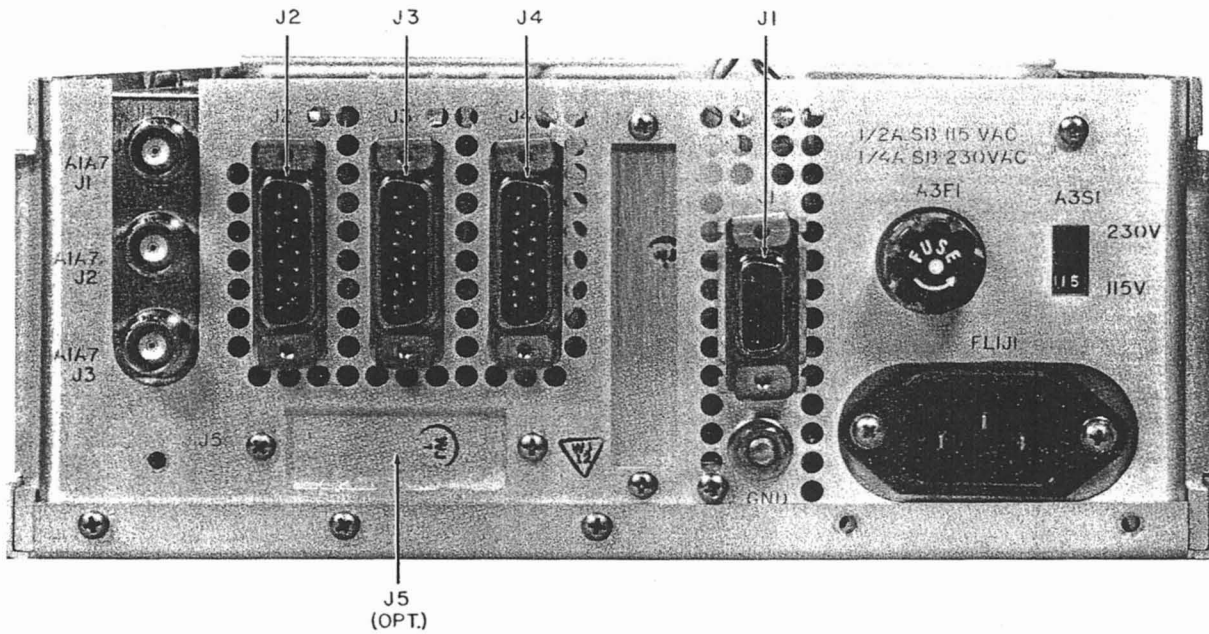

Figure 5-2. WJ-9205 Signal Monitor, Rear View

SECTION V

REPLACEMENT PARTS LIST

5.1 UNIT NUMBERING METHOD

The method of numbering used throughout the unit is assigning reference designations (electrical symbol numbers) to identify: assemblies, subassemblies, modules within a subassembly, and discrete components. An example of the unit numbering method used is as follows:

Subassembly Designation A1

Identify from right to left as:

R1 Class and No. of ItemFirst (1) resistor (R) of
first (1) subassembly (A)

On the main chassis schematic, components which are an integral part of the main chassis have no subassembly designations.

5.2 REFERENCE DESIGNATION PREFIX

The use of partial reference designations are used on the equipment and on the manual illustrations. This partial reference designation consists of the component type letter(s) and the identifying component number. The complete reference designation may be obtained by placing the proper prefix before the partial reference designation. Reference designation prefixes are included on the drawings and illustrations in the figure titles (in parenthesis).

5.3 LIST OF MANUFACTURERS

<u>Mfr. Code</u>	<u>Name and Address</u>	<u>Mfr. Code</u>	<u>Name and Address</u>
00681	Catalyst Research Corp. 1421 Clarkview Road Baltimore, MD 21209	02114	Amperex Electronics Corp. 5083 Rings Highway Saugerties, NY 12477
00779	AMP Inc. P.O. Box 3608 Harrisburg, PA 17105	04597	Projects Unlimited Inc. 3680 Wyse Road P.O. Box 14538 Dayton, OH 45414
01121	Allen-Bradley Company 1201 South Second Street Milwaukee, WI 53204	04713	Motorola, Inc. 5005 East McDowell Road Phoenix, AZ 85008
01295	Texas Instruments, Inc. 13500 North Central Expressway Dallas, TX 75231	05245	Components Corporation 2857 North Halstead Street Chicago, IL 60657

REPLACEMENT PARTS LIST

WJ-9205

<u>Mfr. Code</u>	<u>Name and Address</u>	<u>Mfr. Code</u>	<u>Name and Address</u>
07263	Fairchild Semi-Conductor Corp. 464 Ellis Street Mt. View, CA 94040	19505	Applied Engineering Products 1475 Whalley Ave. New Haven, CT 06525
09021	Airco Electronics Bradford, PA 16701	22526	Berg Electronics, Inc. Route 83 New Cumberland, PA 17070
09353	C&K Components, Inc. 103 Morse Street Watertown, MA 02172	23936	Pamotor Division W.J. Prudy Co. 770 Airport Blvd. Burlington, CA 94010
11711	General Instrument Corp. Rectifier Division Hicksville, NY 11802	24355	Analog Devices, Inc. P.O. Box 280 Norwood, MA 02062
13103	Thermalloy Company 2021 W. Valley View Lane Dallas, TX 75234	25088	Siemens America, Inc. 186 Wood Avenue S. Iselin, NJ 08830
14632	Watkins-Johnson Company 700 Quince Orchard Road Gaithersburg, MD 20878	25120	Piezo Technology, Inc. P.O. Box 7877 2400 Diversified Way Orlando, FL 32804
14752	Electro Cube Inc. 1710 S. Del Mar Drive San Gabriel, CA 91776	27014	National-Semi Conductor Corp. 2950 San Ysidro Way Santa Clara, CA 95051
15542	Mini-Circuits Lab. 2913 Quentin Road Brooklyn, NY 11229	27264	Molex Inc. 2222 Wellington Court Lisle, IL 60532
15912	T/B Ansley Electronics 4371 Valley Blvd. Los Angeles, CA 90065	28480	Hewlett-Packard Company 1501 Page Mill Road Palo Alto, CA 94304
17856	Siliconix, Incorporated 2201 Laurelwood Road Santa Clara, CA 95050	29990	American Technical Ceramics Industries 1 Norden Lane Huntington Station, NY 11746
18324	Signetics Corporation 811 East Argues Avenue Sunnyvale, CA 94086	31745	Rogers Corporation Williams Field and Dobson Road P.O. Box 700 Chandler, AZ 85224

<u>Mfr. Code</u>	<u>Name and Address</u>	<u>Mfr. Code</u>	<u>Name and Address</u>
33095	Spectrum Control Inc. 152 E. Main Street Fairview, PA 16415	61892	NEC Electronics USA Inc. 1 Natrick Executive Pk. Natricks, MA 01760
4W715	Linear Technology 1630 McCarthy Blvd. Milpitas, CA 95035	62786	Hitachi America 1800 Bering Drive San Jose, CA 95122
51642	Centre Engineering Inc. 2820 E. College Avenue State College, PA 16801	7W259	Tel Cal Corporation 9108 Mayflower Avenue El Paso, TX 79925
52648	Plessy Semi-Conductors 1641 Kaiser Irvine, CA 92714	71279	Cambridge Thermionic Corp. 445 Concord Avenue Cambridge, MA 02138
52673	KSW Electronics Corp. South Bedford Street Burlington, MA 01803	71400	Bussman Division of McGraw Edison Co. P.O. Box 14460 St. Louis, MO 63178
54473	Matsushita Elec. Corp. One Panasonic Way P.O. Box 1501 Secaucus, NJ 07094	71785	TRW Electronics Components 1501 Morse Avenue El Grove Village, IL 60007
55027	Q-Bit Corporation 311 Pacific Avenue Palm Bay, FL 32905	73138	Beckman Instruments, Inc. 2500 Harbor Blvd. Fullerton, CA 92634
56289	Sprague Electronic Company Marshall Street North Adams, MA 01248	75915	Littlefuse, Inc. 800 E Northwest Highway Des Plaines, IL 60016
59660	Tusonix Inc. 2155 N. Forbes Blvd. Suite 107 Tucson, AZ 85745	76493	Bell Industries, Inc. P.O. Box 5825 19070 Reyes Avenue Compton, CA 90024

<u>Mfr. Code</u>	<u>Name and Address</u>	<u>Mfr. Code</u>	<u>Name and Address</u>
8K838	Varo P.O. Box 469013 1000 N. Shilak Garland, TX 75046-9013	81350	Joint Army-Navy Specifications
80058	Joint Electronics Type Designation Systems	81483	International Rectifier Corp. 9220 Sunset Blvd. Los Angeles, CA 90054
80131	Electronics Industries Assoc. Washington, DC 20036	82389	Switch Craft, Inc. 555 North Elston Avenue Chicago, IL 60630
81073	Grayhill, Inc. 561 Hill Grove Avenue P.O. Box 10373 LaGrange, IL 60525	91293	Johanson Mfg. Company P.O. Box 329 Boonton, NJ 07005
81349	Military Specifications	96906	Military Standards
		99800	Delevan Electronics Division 270 Quaker Road East Aurora, NY 14052

5.4 PARTS LIST

The following parts lists contain all the electrical components used in the unit, along with mechanical parts which may be subject to unusual wear or damage. When ordering replacement parts from the Watkins-Johnson Company, specify the unit type and serial number. Also include the reference designation and the description of each item ordered. The list of manufacturers, provided in **paragraph 5.3**, and the manufacturer's part number, provided in **paragraph 5.5**, are supplied as a guide to aid the user of the equipment while in the field. The parts listed may not necessarily be identical with the parts installed in the unit. The parts listed in **paragraph 5.5** will provide for satisfactory unit operation.

Replacement parts may be obtained from any manufacturer provided that the physical characteristics and electrical parameters of the replacement item are compatible with the original part. In the case where components are defined by a military or industrial specification, a vendor which can provide the necessary component is suggested as a convenience to the user.

NOTE

As improvements in semiconductors are made, it is the policy of Watkins-Johnson to incorporate them in proprietary products. As a result, some transistors, diodes and integrated circuits which are installed in the unit may not agree with the parts lists or schematic diagrams of this manual. However, substitution of the semiconductor devices listed in this manual may be substituted with satisfactory results.

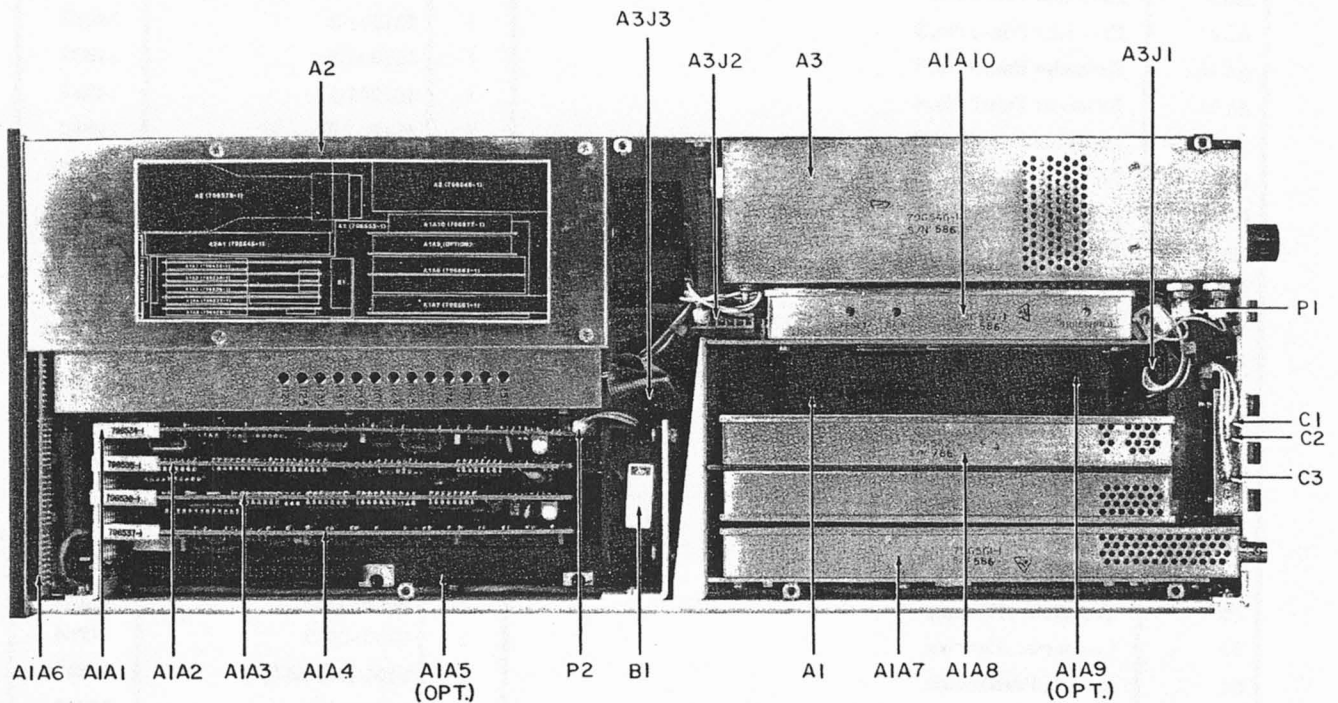

Figure 5-3. WJ-9205 Signal Monitor, Top View

5.5 TYPE WJ-9205 SIGNAL MONITOR

MAIN CHASSIS

REF DESIG	DESCRIPTION	QTY PER ASSY	MANUFACTURER'S PART NO.	MFR. CODE	RECM VENDOR
	Revision C				
A1	Motherboard Assembly	1	796533-1	14632	
A2	High Voltage Power Supply/Deflect Amplifier	1	796782-1	14632	
A3	Low Voltage Power Supply Assembly	1	796771-1	14632	
A4	Keyboard Display Assembly	1	796539-1	14632	
AI-1	Cord, AC Line	1	17600	16428	
AI-8	Extender Board No. 1	1	381200-1	14632	
AI-9	Extender Board No. 2	1	381200-2	14632	
AI-10	Extender Board No. 3	1	381200-3	14632	
AI-11	Extender Board No. 4	1	381201-1	14632	
AI-12	Extender Board No. 5	1	381201-2	14632	
B1	Blower Fan	1	814	23936	
C1	Filter	3	4101-000	59660	
C2	Same as C1				
C3	Same as C1				
F1	Fuse, 3/4 Amp, Slo-Blow	1	MDL 3/4	71400	
FL1	Filter, Power Line	1	1EF1	05245	
FL2	Filter Box	1	281499-1	14632	
J1	Connector, Filtered	1	842925-3	00779	
J2	Connector, Plug	3	205206-1	00779	
J3	Same as J2				
J4	Same as J2				
P1	Connector, Plug	1	65043-025	22526	
P2	Connector, Housing	1	09-50-7031	27264	
P3	Connector, Housing	1	09-50-3091	27264	
S1	Switch, Pushbutton	1	8161-S-H-Z3-Q-E	09353	
S2	Switch, Slide	1	46256LFR	82389	
T1	Transformer Power	1	841337	14632	
XF1	Fuseholder	1	342004	75915	

5.5.1 TYPE 796533-1 MOTHERBOARD ASSEMBLY

REF DESIG PREFIX A1

REF DESIG	DESCRIPTION	QTY PER ASSY	MANUFACTURER'S PART NO.	MFR. CODE	RECM VENDOR
	Revision D1				
A1	Microprocessor Assembly	1	796534-1	14632	
A2	Data Acquisition Assembly	1	796535-1	14632	
A3	DRD/Timing Controller Assembly	1	796536-1	14632	
A4	Input/Output Assembly	1	796537-1	14632	
A5	Remote Interface Assembly (Optional)	1	796538-1	14632	
A6	Not Used				
A7	Input Control	1	796561-1	14632	
A8	Frequency Converter, Sweep	1	796562-1	14632	
A9	Second IF Assembly (Optional)	1	796790-1	14632	
A10	Log IF/Detector Assembly	1	796577-1	14632	
C1	Capacitor, Electrolytic, Tantalum: 27 μ F, 10%, 35 V	2	CS13BF276K	81349	
C2	Same as C1				
C3	Capacitor, Electrolytic, Tantalum: 100 μ F, 20%, 20 V	3	196D107X0020TE4	56289	
C4	Same as C3				
C5	Same as C3				
J1	Header, Modified	1	281508-1	14632	
J2	Connector, Modified	1	281388-3	14632	
J3	Connector, Receptacle	1	87215-8	00779	
J4	Connector, Modified	1	281388-1	14632	
J5	Header Assembly	1	609-3427	15912	
R1	Resistor, Fixed, Film: 68 Ω , 5%, 1/4 W	2	CF1/4-68 OHMS/J	09021	
R2	Same as R1				
XA1	Header Assembly	5	5189-18-84	00779	
XA2 Thru XA5	Same as XA1				
XA6	Not Used				
XA7	Header Assembly	6	5189-18-82	00779	
XA8 Thru XA10	Same as XA7				
XA2B	Header Assembly	2	5189-18-81	00779	
XA3B	Same as XA2B				
XA4B	Header Assembly	1	5189-18-83	00779	
XA8B	Same as XA7				
XA9B	Same as XA7				

5.5.1.1 Type 796534-1 Microprocessor Assembly

REF DESIG PREFIX A1A1

REF DESIG	DESCRIPTION	QTY PER ASSY	MANUFACTURER'S PART NO.	MFR. CODE	RECM VENDOR
	Revision B1				
BT1	Battery	1	1935-DE	00681	
C1	Capacitor, Ceramic, Disc: .1 μ F, 20%, 50 V	2	34475-1	14632	
C2	Capacitor, Electrolytic, Tantalum: 22 μ F, 20%, 10 V	1	196D226X0010JE3	56289	
C3	Capacitor, Micro-Q, Dip: .03 μ F, 50 V	3	1R0GUQ01A	31745	
C4	Same as C1				
C5	Same as C3				
C6	Capacitor, Ceramic, Monolithic: 27 pF, \pm 2%, 100 V	2	150-100-NPO-270G	51642	
C7	Same as C6				
C8					
Thru C10	Not Used				
C11	Capacitor, Micro-Q, Dip: .03 μ F, 50 V	2	1R0GUQ08A	31745	
C12	Capacitor, Micro-Q, Dip: .03 μ F, 50 V	4	1R0GUQ04A	31745	
C13					
Thru C15	Same as C12				
C16	Capacitor, Micro-Q, Dip: .03 μ F, 50 V	1	1R0GUQ02A	31745	
C17	Capacitor, Ceramic, Disc: .01 μ F, 20%, 50 V	1	34453-1	14632	
C18	Capacitor, Ceramic, Disc: 0.47 μ F, 10%, 50 V	1	8131-050-X7RO-474K	59660	
C19	Same as C11				
C20	Capacitor, Electrolytic, Tantalum: 47 μ F, 10%, 20 V	1	CS13BE476K	81349	
C21	Same as C3				
C22	Capacitor, Ceramic, Monolithic: 470 pF, \pm 2%, 100 V	1	150-100-NPO-471G	51642	
CR1	Diode	1	1N748A	80131	
CR2	Diode	1	1N4449	80131	
CR3	Diode	1	5082-2800	28480	
P1	Receptacle Assembly	1	66527-036	22526	
Q1	Transistor	2	2N4403	80131	
Q2	Transistor	1	2N4401	80131	
Q3	Same as Q1				
R1	Resistor, Fixed, Film: 47 k Ω , 5%, 1/4 W	5	CF1/4-47K/J	09021	
R2					
Thru R5	Same as R1				
R6	Resistor, Fixed, Film: 5.6 k Ω , 5%, 1/4 W	1	CF1/4-5.6K/J	09021	
R7	Resistor, Trimmer, Film: 1 k Ω , 10%, 1/2 W	1	62PAR1K	73138	
R8	Resistor, Fixed, Film: 1.0 k Ω , 5%, 1/4 W	1	CF1/4-1K/J	09021	
R9	Resistor, Fixed, Film: 470 k Ω , 5%, 1/4 W	1	CF1/4-470K/J	09021	
R10	Resistor, Fixed, Film: 10 k Ω , 5%, 1/4 W	1	CF1/4-10K/J	09021	
R11	Resistor, Fixed, Film: 22 k Ω , 5%, 1/4 W	2	CF1/4-22K/J	09021	
R12	Resistor, Fixed, Film: 1.0 M Ω , 5%, 1/4 W	1	CF1/4-1M/J	09021	
R13	Same as R11				
R14	Resistor, Fixed, Film: 470 Ω , 5%, 1/4 W	1	CF1/4-470 OHMS/J	09021	

REF DESIG PREFIX A1A1

REF DESIG	DESCRIPTION	QTY PER ASSY	MANUFACTURER'S PART NO.	MFR. CODE	RECM VENDOR
R15	Resistor, Fixed, Film: 2.2 k Ω , 5%, 1/4 W	2	CF1/4-2.2K/J	09021	
R16	Same as R15				
U1	Programmed EPROM	1	841236	14632	
U2	Not Used				
U3	Resistor, Network: 100 k Ω , 2%, 1/8 W	3	L10-1C104	73138	
U4	Not Used				
U5	Integrated Circuit, RAM	1	HM6264LP-12	62786	
U6	Same as U3				
U7	DIP Shunt	1	1-435704-0	00779	
U8	Integrated Circuit	1	MC6809P	04713	
U9	Same as U3				
U10	Integrated Circuit	1	SN74ALS32N	01295	
U11	Integrated Circuit	1	MM74HC14N	27014	
U12	Integrated Circuit	2	MM74HC00N	27014	
U13	Integrated Circuit	1	MM74HCT245N	27014	
U14	Integrated Circuit	3	MM74HCT244N	27014	
U15	Same as U14				
U16	Integrated Circuit, PROM	1	841279	14632	
U17	Same as U12				
U18	Same as U14				
U19	Integrated Circuit	1	SN74LS221N	01295	
Y1	Crystal, Quartz	1	CR64/4 5.24 MHz	80058	

5.5.1.2 Type 796535-1 Data Acquisition Assembly

REF DESIG PREFIX A1A2

REF DESIG	DESCRIPTION	QTY PER ASSY	MANUFACTURER'S PART NO.	MFR. CODE	RECM VENDOR
	Revision D1				
C1	Capacitor, Ceramic, Disc: .47 μ F, 20%, 50 V	11	34452-1	14632	
C2 Thru C4	Same as C1				
C5	Capacitor, Electrolytic, Disc: .1 μ F, 20%, 50 V	5	34475-1	14632	
C6	Same as C5				
C7	Capacitor, Ceramic, Monolithic: 1000 pF, \pm 2%, 100 V	1	150-100-NPO-102G	51642	
C8	Capacitor, Electrolytic, Tantalum: 100 μ F, 20%, 20 V	2	196D107X0020TE4	56289	
C9	Same as C8				
C10	Capacitor, Electrolytic, Tantalum: 22 μ F, 20%, 10 V	2	196D226X0010JE3	56289	
C11	Same as C1				
C12	Capacitor, Electrolytic, Tantalum: 4.7 μ F, 20%, 35 V	4	196D475X0035JE3	56289	
C13	Same as C12				
C14	Same as C1				
C15	Same as C5				
C16	Same as C5				
C17	Capacitor, Micro-Q, Dip: .03 μ F, 50 V	6	1R0GUQ04A	31745	
C18	Same as C17				
C19	Same as C17				
C20	Same as C1				
C21	Capacitor, Electrolytic, Tantalum: 18 μ F, 10%, 20 V	3	196D186X9020KE3	56289	
C22	Not Used				
C23	Same as C17				
C24	Same as C12				
C25	Same as C1				
C26	Capacitor, Ceramic, Monolithic: 330 pF, \pm 2%, 100 V	1	150-100-NPO-331G	51642	
C27	Same as C1				
C28	Capacitor, Ceramic, Monolithic: 22 pF, \pm 2%, 100 V	1	100-100-NPO-220G	51642	
C29	Same as C17				
C30	Same as C1				
C31	Same as C21				
C32	Same as C12				
C33	Same as C1				
C34	Same as C21				
C35	Same as C5				
C36	Same as C17				
C37	Capacitor, Ceramic, Disc: 1000 pF, 10%, 200 V	1	CK05BX102K	81349	
C38	Capacitor, Ceramic, Disc: 3300 pF, 10%, 200 V	1	CK06BX332K	81349	
CR1	Diode	1	1N4449	80131	
P1	Receptacle Assembly	1	66527-036	22526	
P2	Receptacle Assembly	1	66527-006	22526	
R1	Resistor, Fixed, Film: 100 Ω , 5%, 1/4 W	9	CF1/4-100 OHMS/J	09021	

REF DESIG PREFIX A1A2

REF DESIG	DESCRIPTION	QTY PER ASSY	MANUFACTURER'S PART NO.	MFR. CODE	RECM VENDOR
R2 Thru R5	Same as R1				
R6	Resistor, Fixed, Film: 10 Ω , 5%, 1/8 W	1	CF1/8-10 OHMS/J	09021	
R7	Resistor, Fixed, Film: 1.0 k Ω , 1%, 1/10 W	6	RN55C1001F	81349	
R8 Thru R10	Same as R1				
R11	Same as R7				
R12	Same as R1				
R13	Resistor, Fixed, Film: 60.4 k Ω , \pm 1%, 1/10 W	1	RN55C6042F	81349	
R14	Resistor, Fixed, Film: 20 k Ω , 1%, 1/10 W	1	RN55C2002F	81349	
R15	Resistor, Fixed, Film: 10 k Ω , 1%, 1/10 W	4	RN55C1002F	81349	
R16	Resistor, Fixed, Film: 6.04 k Ω , 1%, 1/10 W	1	RN55C6041F	81349	
R17	Resistor, Fixed, Film: 2.0 k Ω , 1%, 1/10 W	1	RN55C2001F	81349	
R18 Thru R21 R22 Thru R24	Same as R7				
R25	Resistor, Fixed, Film: 39.2 k Ω , 1%, 1/10 W	1	RN55C3922F	81349	
R26	Resistor, Fixed, Film: 470 Ω , 5%, 1/4 W	1	CF1/4-470 OHMS/J	09021	
R27	Resistor, Fixed, Film: 47 k Ω , 5%, 1/8 W	6	CF1/8-47K/J	09021	
R28 Thru R32	Same as R27				
U1	Integrated Circuit	4	MM74HC374N	27014	
U2	Integrated Circuit	1	MM74HC4040N	27014	
U3	Same as U1				
U4	Integrated Circuit	1	MM74HC4051N	27014	
U5	Integrated Circuit	4	LM336Z-5.0	27014	
U6	Integrated Circuit	1	DAC1022LCN	27014	
U7	Same as U1				
U8	Same as U1				
U9	Integrated Circuit	1	L1007CN8	4W715	
U10	Integrated Circuit	2	MC34002P	04713	
U11	Same as U5				
U12	Integrated Circuit	1	DG301ACJ	17856	
U13	Integrated Circuit	2	MM74HC244N	27014	
U14	Same as U13				
U15	Integrated Circuit	1	MM74HC74N	27014	
U16	Integrated Circuit	1	ADC0820BCN	27014	
U17	Same as U5				
U18	Integrated Circuit	1	DG302CJ	17856	

REPLACEMENT PARTS LIST

WJ-9205

REF DESIG PREFIX A1A2

REF DESIG	DESCRIPTION	QTY PER ASSY	MANUFACTURER'S PART NO.	MFR. CODE	RECM VENDOR
U19	Same as U5				
U20	Same as U10				
U21	Integrated Circuit	1	MM74HC151N	27014	

5.5.1.3 Type 796536-1 DRD/Timing Controller Assembly

REF DESIG PREFIX A1A3

REF DESIG	DESCRIPTION	QTY PER ASSY	MANUFACTURER'S PART NO.	MFR. CODE	RECM VENDOR
	Revision D1				
C1	Capacitor, Electrolytic, Tantalum: 4.7 μ F, 20%, 35 V	5	196D475X0035JE3	56289	
C2	Capacitor, Electrolytic, Tantalum: 1 μ F, 20%, 35 V	2	196D105X0035HE3	56289	
C3	Capacitor, Ceramic, Monolithic: 10000 pF, \pm 2%, 100 V	1	300-100-NPO-103G	51642	
C4	Same as C2				
C5	Same as C1				
C6	Capacitor, Ceramic, Monolithic: 100 pF, \pm 2%, 100 V	2	200-100-NPO-101G	51642	
C7	Capacitor, Ceramic, Monolithic: 1000 pF, \pm 2%, 100 V	2	150-100-NPO-102G	51642	
C8	Capacitor, Ceramic, Monolithic: 470 pF, \pm 2%, 100 V	1	150-100-NPO-471G	51642	
C9	Same as C7				
C10	Capacitor, Ceramic, Monolithic: .01 μ F, \pm 5%, 100 V	1	150-100-X7R-103J	51642	
C11	Capacitor, Ceramic, Monolithic: 22 pF, \pm 2%, 100 V	2	100-100-NPO-220G	51642	
C12	Same as C11				
C13	Same as C6				
C14	Same as C1				
C15	Capacitor, Ceramic, Tantalum: 100 μ F, 20%, 20 V	2	196D107X0020TE4	56289	
C16	Same as C15				
C17	Capacitor, Micro-Q, Dip: .03 μ F, 50 V	7	1R0GUQ04A	31745	
C18 Thru C23	Same as C17				
C24	Capacitor, Electrolytic, Tantalum: 18 μ F, 10%, 20 V	1	196D186X9020KE3	56289	
CR1	Diode	3	1N4449	80131	
CR2	Same as CR1				
CR3	Same as CR1				
P1	Receptacle Assembly	1	66527-036	22526	
P2	Receptacle Assembly	1	66527-006	22526	
Q1	Transistor	1	2N3904	80131	
Q2	Transistor	1	2N3906	80131	
R1	Resistor, Fixed, Film: 470 Ω , 5%, 1/4 W	4	CF1/4-470 OHMS/J	09021	
R2	Resistor, Fixed, Film: 1.0 k Ω , 5%, 1/4 W	1	CF1/4-1K/J	09021	
R3	Resistor, Fixed, Film: 10 k Ω , 5%, 1/4 W	4	CF1/4-10K/J	09021	
R4	Same as R3				
R5	Resistor, Fixed, Film: 4.75 k Ω , 1%, 1/10 W	1	RN55C4751F	81349	
R6	Resistor, Fixed, Film: 10 k Ω , 1%, 1/10 W	6	RN55C1002F	81349	
R7	Resistor, Trimmer, Film: 50 k Ω , 10%, 1/2 W	1	62PAR50K	73138	
R8	Resistor, Fixed, Film: 130 k Ω , 5%, 1/4 W	1	CF1/4-130K/J	09021	
R9	Resistor, Fixed, Film: 22.1 k Ω , 1%, 1/10 W	1	RN55C2212F	81349	
R10 Thru R14	Same as R6				
R15	Resistor, Fixed, Film: 1.3 k Ω , 5%, 1/8 W	1	CF1/8-1.3K/J	09021	
R16	Resistor, Fixed, Film: 4.7 k Ω , 5%, 1/4 W	2	CF1/4-4.7K/J	09021	
R17	Same as R1				

REF DESIG PREFIX A1A3

REF DESIG	DESCRIPTION	QTY PER ASSY	MANUFACTURER'S PART NO.	MFR. CODE	RECM VENDOR
R18	Resistor, Fixed, Film: 2.2 k Ω , 5%, 1/4 W	3	CF1/4-2.2K/J	09021	
R19	Same as R18				
R20	Same as R1				
R21	Same as R3				
R22	Same as R3				
R23	Same as R18				
R24	Same as R16				
R25	Resistor, Fixed, Film: 27 k Ω , 5%, 1/4 W	1	CF1/4-27K/J	09021	
R26	Resistor, Fixed, Film: 47 Ω , 5%, 1/4 W	1	CF1/4-47 OHMS/J	09021	
R27	Same as R1				
R28	Resistor, Fixed, Film: 10 Ω , 5%, 1/4 W	1	CF1/4-10 OHMS/J	09021	
U1	Integrated Circuit	2	MM74HC4040N	27014	
U2	Integrated Circuit	2	MM74HC244N	27014	
U3	Same as U2				
U4	Integrated Circuit	3	MM74HC74N	27014	
U5	Integrated Circuit	1	MM74HC00N	27014	
U6	Integrated Circuit	1	MM74HC251N	27014	
U7	Same as U1				
U8	Voltage Regulator	1	LM78L12CZ	27014	
U9	Integrated Circuit	4	MM74HC374N	27014	
U10	Same as U4				
U11	Same as U9				
U12	Integrated Circuit	2	MM74HC138N	27014	
U13	Integrated Circuit	1	MM74HC08N	27014	
U14	Same as U12				
U15	Same as U9				
U16	Integrated Circuit	1	DAC1022LCN	27014	
U17	Integrated Circuit	1	MM74HC245N	27014	
U18	Integrated Circuit, RAM	1	HM6264LP-12	62786	
U19	Integrated Circuit	1	MM74HC32N	27014	
U20	Same as U9				
U21	Integrated Circuit	2	TL074CN	01295	
U22	Same as U21				
U23	Integrated Circuit	1	TL082ACP	01295	
U24	Integrated Circuit	1	AD7528JN	24355	
U25	Integrated Circuit	1	LM336Z-5.0	27014	
U26	Not Used				
U27	Same as U4				

5.5.1.4 Type 796537-1 Input/Output Assembly

REF DESIG PREFIX A1A4

REF DESIG	DESCRIPTION	QTY PER ASSY	MANUFACTURER'S PART NO.	MFR. CODE	RECM VENDOR
	Revision B1				
C1	Capacitor, Ceramic, Disc: .01 μ F, 20%, 50 V	1	34453-1	14632	
C2	Capacitor, Electrolytic, Tantalum: 4.7 μ F, 10%, 35 V	4	CS13BF475K	81349	
C3	Capacitor, Micro-Q, Dip: .03 μ F, 50 V	11	1R0GUQ04A	31745	
C4	Same as C2				
C5	Same as C3				
C6	Same as C2				
C7	Same as C3				
C8	Same as C2				
C9	Same as C3				
Thru C16	Same as C3				
CR1	Diode	1	5082-2800	28480	
CR2	Diode	1	1N4449	80131	
LS1	Alarm	1	AT-20K	04597	
P1	Receptacle Assembly	1	66527-036	22526	
P2	Receptacle Assembly	1	66527-030	22526	
R1	Resistor, Fixed, Film: 10 k Ω , 1%, 1/10 W	4	RN55C1002F	81349	
R2	Resistor, Fixed, Film: 200 k Ω , 1%, 1/10 W	2	RN55C2003F	81349	
R3	Same as R2				
R4	Resistor, Fixed, Film: 2.0 k Ω , 1%, 1/10 W	4	RN55C2001F	81349	
R5	Resistor, Fixed, Film: 100 k Ω , 1%, 1/10 W	1	RN55C1003F	81349	
R6	Same as R1				
R7	Resistor, Fixed, Film: 22.1 k Ω , 1%, 1/10 W	1	RN55C2212F	81349	
R8	Same as R4				
R9	Same as R4				
R10	Same as R1				
R11	Same as R4				
R12	Same as R1				
R13	Resistor, Fixed, Film: 470 Ω , 5%, 1/8 W	1	CF1/8-470 OHMS/J	09021	
U1	Integrated Circuit	1	LM336Z-5.0	27014	
U2	Integrated Circuit	1	MC1458N	18324	
U3	Integrated Circuit	1	MM74HC02N	27014	
U4	Integrated Circuit	2	MM74HC08N	27014	
U5	Same as U4				
U6	Integrated Circuit	1	MM74HC4078N	27014	
U7	Integrated Circuit	2	MM74HC74N	27014	
U8	Integrated Circuit	4	MM74HC138N	27014	
U9	Same as U8				
U10	Same as U8				
U11	Same as U7				

REPLACEMENT PARTS LIST

WJ-9205

REF DESIG PREFIX A1A4

REF DESIG	DESCRIPTION	QTY PER ASSY	MANUFACTURER'S PART NO.	MFR. CODE	RECM VENDOR
U12	Integrated Circuit	1	MM74HC4040N	27014	
U13	Integrated Circuit	1	MM74HC245N	27014	
U14	Same as U8				
U15	Integrated Circuit	1	ADC0809CCN	27014	
U16	Resistor, Network: 100 kΩ, 2%, 1/8 W	3	L10-1C104	73138	
U17	Integrated Circuit	3	MM74HC244N	27014	
U18	Integrated Circuit	7	MM74HC374N	27014	
U19	Same as U17				
U20					
Thru	Same as U18				
U22					
U23	Same as U16				
U24					
Thru	Same as U18				
U26					
U27	Same as U17				
U28	Same as U16				

5.5.1.5 Type 796538-1 Remote Interface Assembly (Optional)

REF DESIG PREFIX A1A5

REF DESIG	DESCRIPTION	QTY PER ASSY	MANUFACTURER'S PART NO.	MFR. CODE	RECM VENDOR
	Revision B1				
C1	Capacitor, Electrolytic, Tantalum: 4.7 μ F, 20%, 35 V	2	196D475X0035JE3	56289	
C2	Capacitor, Electrolytic, Tantalum: 22 μ F, 20%, 10 V	1	196D226X0010JE3	56289	
C3	Same as C1				
C4	Capacitor, Ceramic, Disc: .1 μ F, 20%, 50 V	11	34475-1	14632	
C5	Same as C4				
C6	Same as C4				
C7	Capacitor, Electrolytic, Tantalum: 2.2 μ F, 20%, 35 V	4	196D225X0035JE3	56289	
C8	Same as C7				
C9	Same as C4				
C10	Not Used				
C11	Not Used				
C12					
Thru C18	Same as C4				
C19	Same as C7				
C20	Same as C7				
CR1	Diode	1	1N4449	80131	
J1	Connector, Receptacle	1	86479-7	00779	
J2	Not Used				
P1	Receptacle Assembly	1	66527-036	22526	
R1	Resistor, Fixed, Film: 1.0 M Ω , 5%, 1/8 W	1	CF1/8-1M/J	09021	
R2	Resistor, Fixed, Film: 47 k Ω , 5%, 1/8 W	2	CF1/8-47K/J	09021	
R3	Same as R2				
S1	Switch/Dip	1	76PSB08S	81073	
U1	Integrated Circuit	1	841137-1	14632	
U2	Integrated Circuit	1	MM74HC04N	27014	
U3	Integrated Circuit, GPIB	1	PD7210C	61892	
U4	Integrated Circuit	1	841137-2	14632	
U5	Resistor, Network: 100 k Ω , 2%, 1/8 W	1	L10-1C104	73138	
U6	Integrated Circuit, Buffer	1	MM74HCT244N	27014	
U7	Not Used				
U8	Integrated DC Drive	1	MM74HCT138N	27014	
U9	Integrated Circuit	1	MM74HC32N	27014	
U10	Not Used				
U11	Not Used				
U12	Not Used				
U13	Not Used				
U14	Not Used				
U15	Not Used				
Y1	Not Used				

5.5.1.6 **Type 796561-1 Input Control Assembly**

REF DESIG PREFIX A1A7

REF DESIG	DESCRIPTION	QTY PER ASSY	MANUFACTURER'S PART NO.	MFR. CODE	RECM VENDOR
	Revision A				
A1	Input Selector/Step Attenuator Assembly	1	796500-1	14632	
A2	Input Filter 21.4 MHz Marker	1	796544-1	14632	
C1	Capacitor, Ceramic, Feedthru: 1000 pF, 500 V	11	54-794-009-102W	33095	
C2 Thru C11	Same as C1				
J1	Connector, Receptacle	3	UG1094U	80058	
J2	Same as J1				
J3	Same as J1				
P1	Receptacle Assembly	1	66527-010	22526	
P2	Connector, Plug	1	2005-1551-003	19505	

5.5.1.6.1 Type 796500-1 Input Selector/Step Attenuator Assembly

REF DESIG PREFIX A1A7A1

REF DESIG	DESCRIPTION	QTY PER ASSY	MANUFACTURER'S PART NO.	MFR. CODE	RECM VENDOR
	Revision B1				
C1	Capacitor, Ceramic, Disc: .01 μ F, 20%, 50 V	38	34453-1	14632	
C2 Thru C19	Same as C1				
C20	Capacitor, Electrolytic, Tantalum: 4.7 μ F, 20%, 35 V	1	196D475X0035JE3	56289	
C21 Thru C39	Same as C1				
CR1	Diode, Pin	24	KS3542	52673	
CR2 Thru CR24	Same as CR1				
L1	Coil, Fixed: 18 μ H, 10%	11	1025-50 (75084-15)	99800	
L2 Thru L11	Same as L1				
L12	Coil, Fixed, Molded: 4.7 μ H, 10%	2	1025-36 (75084-8)	99800	
L13	Same as L12				
R1	Resistor, Fixed, Film: 10 Ω , 5%, 1/4 W	6	CF1/4-10 OHMS/J	09021	
R2	Same as R1				
R3	Resistor, Fixed, Film: 10 k Ω , 5%, 1/4 W	7	CF1/4-10K/J	09021	
R4 Thru R6	Same as R3				
R7	Resistor, Fixed, Film: 2.2 k Ω , 5%, 1/4 W	1	CF1/4-2.2K/J	09021	
R8	Resistor, Fixed, Film: 47 Ω , 5%, 1/4 W	3	CF1/4-47 OHMS	09021	
R9	Resistor, Fixed, Film: 2.7 k Ω , 5%, 1/4 W	16	CF1/4-2.7K/J	09021	
R10	Same as R9				
R11	Same as R9				
R12	Same as R8				
R13 Thru R15	Same as R9				
R16	Same as R8				
R17 Thru R19	Same as R9				
R20	Same as R1				
R21	Same as R9				
R22 Thru R24	Same as R3				
R25 Thru R37	Not Used				
R38	Same as R9				
R39	Resistor, Fixed, Film: 27 Ω , 5%, 1/4 W	2	CF1/4-27 OHMS/J	09021	
R40	Resistor, Fixed, Film: 39 Ω , 5%, 1/4 W	5	CF1/4-39 OHMS/J	09021	

REPLACEMENT PARTS LIST

WJ-9205

REF DESIG PREFIX A1A7A1

REF DESIG	DESCRIPTION	QTY PER ASSY	MANUFACTURER'S PART NO.	MFR. CODE	RECM VENDOR
R41	Same as R39				
R42	Same as R9				
R43	Same as R9				
R44	Same as R40				
R45	Same as R1				
R46	Same as R40				
R47	Same as R9				
R48	Same as R9				
R49	Same as R40				
R50	Same as R1				
R51	Resistor, Fixed, Film: 82Ω, 5%, 1/4 W	1	CF1/4-82 OHMS/J	09021	
R52	Same as R1				
R53	Same as R40				
R54	Same as R9				
U1	Integrated Circuit	2	MC3403P	04713	
U2	Same as U1				
U3	Integrated Circuit	1	MC1458N	18324	

5.5.1.6.2 Type 796544-1 Input Filter Assembly

REF DESIG PREFIX A1A7A2

REF DESIG	DESCRIPTION	QTY PER ASSY	MANUFACTURER'S PART NO.	MFR. CODE	RECM VENDOR
	Revision A				
C1	Capacitor, Ceramic, Monolithic: 150 pF, $\pm 2\%$, 100 V	2	150-100-NPO-151G	51642	
C2	Capacitor, Ceramic, Monolithic: 240 pF, $\pm 2\%$, 100 V	2	150-100-NPO-241G	51642	
C3	Capacitor, Ceramic, Monolithic: 270 pF, $\pm 2\%$, 100 V	1	150-100-NPO-271G	51642	
C4	Same as C2				
C5	Same as C1				
C6	Capacitor, Ceramic, Disc: .01 μ F, 20%, 50 V	5	34453-1	14632	
C7	Same as C6				
C8	Capacitor, Electrolytic, Tantalum: 4.7 μ F, 20%, 35 V	2	196D475X0035JE3	56289	
C9	Same as C6				
C10	Same as C6				
C11	Same as C8				
C12	Same as C6				
L1	Inductor: .487 μ H, 1%	2	L10-0R487	7W259	
L2	Inductor: .464 μ H, 1%	2	L10-0R464	7W259	
L3	Same as L2				
L4	Same as L1				
L5	Coil, Fixed: 47 μ H, 10%	1	1025-60 (75085-3)	99800	
Q1	Transistor	2	U310	17856	
Q2	Same as Q1				
R1	Resistor, Fixed, Film: 47 Ω , 5%, 1/4 W	2	CF1/4-47 OHMS	09021	
R2	Resistor, Fixed, Film: 10 Ω , 5%, 1/4 W	2	CF1/4-10 OHMS/J	09021	
R3	Resistor, Fixed, Film: 1.2 k Ω , 5%, 1/4 W	2	CF1/4-1.2K/J	09021	
R4	Same as R3				
R5	Same as R2				
R6	Same as R1				
T1	Transformer	1	T9-1	15542	

5.5.1.7 Type 796562-1 Frequency Converter/Sweep Assembly

REF DESIG PREFIX A1A8

REF DESIG	DESCRIPTION	QTY PER ASSY	MANUFACTURER'S PART NO.	MFR. CODE	RECM VENDOR
	Revision A				
A1	First LO, First Converter, Auto Centering Assembly	1	796540-1	14632	
A2	Second LO, Second Converter Assembly	1	796541-1	14632	
A3	Second IF/RBW (10 kHz) Assembly	1	796542-1	14632	
C1	Filter: 1750 pF	18	4101-000	59660	
C2 Thru C18	Same as C1				
C19	Capacitor, Variable, Air: .8-10.0 pF, 250 V	3	5202 W/LOCK WASHER	91293	
C20	Same as C19				
C21	Same as C19				
C22	Capacitor, Ceramic, Monolithic: 15 pF, $\pm 2\%$, 100 V	2	100-100-NPO-150G	51642	
C23	Capacitor, Ceramic, Monolithic: 10 pF, $\pm 2\%$, 100 V	1	100-100-NPO-100G	51642	
C24	Same as C22				
J1	Connector, Receptacle, SMB	1	2012-7511-000	19505	
L1	Coil, Fixed, Gen Inductor: .178 μ H, 1%	3	L10-OR178	7W259	
L2	Same as L1				
L3	Same as L1				
L4	Coil, Fixed: .47 μ H	2	1025-12	99800	
L5	Same as L4				
L6	Coil, Fixed, 2.2 μ H, 10%	2	1025-28 (75084-4)	99800	
L7	Same as L6				
P1	Receptacle Assembly	2	66527-010	22526	
P2	Same as P1				

5.5.1.7.1 Type 796540-1 First LO/First Converter/
Auto Centering Assembly

REF DESIG PREFIX A1A8A1

REF DESIG	DESCRIPTION	QTY PER ASSY	MANUFACTURER'S PART NO.	MFR. CODE	RECM VENDOR
	Revision C1				
C1	Capacitor, Electrolytic, Tantalum: 18 μ F, 10%, 20 V	10	196D186X9020KE3	56289	
C2	Same as C1				
C3	Same as C1				
C4	Capacitor, Ceramic, Monolithic: 1000 pF, \pm 2%, 100 V	12	150-100-NPO-102G	51642	
C5	Capacitor, Ceramic, Monolithic: 470 pF, \pm 2%, 100 V	3	150-100-NPO-471G	51642	
C6	Capacitor, Ceramic, Chip: 47 pF, 2%, 500 V	1	ATC700B470GP500X	29990	
C7	Capacitor, Ceramic, Monolithic: 2200 pF, \pm 2%, 100 V	2	200-100-NPO-222G	51642	
C8	Capacitor, Ceramic, Disc: 1 μ F, 20%, 50 V	3	8131-050-651-105M	59660	
C9	Same as C8				
C10	Capacitor, Ceramic, Monolithic: 27 pF, \pm 2%, 100 V	2	150-100-NPO-270G	51642	
C11	Same as C10				
C12	Capacitor, Variable, Ceramic: 5-25 pF, 100 V	1	518-000A5-25	59660	
C13	Capacitor, Variable, Air: 1.0-10.0 pF, 250 V	1	8052	91293	
C14	Capacitor, Ceramic, Chip: 4.7 pF, \pm .25 pF, 500 V	1	ATC100B4R7CP500X	29990	
C15	Capacitor, Ceramic, Chip: 10 pF, 2%, 500 V	1	ATC700B100GP500X	29990	
C16	Capacitor, Ceramic, Chip: 24 pF, 5%, 500 V	1	ATC700B240JP500X	29990	
C17	Same as C1				
C18	Same as C1				
C19	Same as C4				
C20	Capacitor, Ceramic, Disc: .01 μ F, 20%, 50 V	2	34453-1	14632	
C21	Capacitor, Electrolytic, Tantalum: 220 μ F, 20%, 10 V	2	196D227X0010FE4	56289	
C22					
Thru C26	Same as C4				
C27	Same as C21				
C28					
Thru C30	Same as C4				
C31	Capacitor, Ceramic, Disc: .1 μ F, 20%, 50 V	1	34475-1	14632	
C32					
Thru C34	Same as C1				
C35	Capacitor, Polycarbonate: .22 μ F, 10%, 135 V	1	912A1C224K	14752	
C36	Same as C1				
C37	Same as C20				
C38	Same as C8				
C39	Same as C5				
C40	Same as C5				
C41	Same as C4				
C42	Same as C4				
C43	Same as C1				
C44	Capacitor, Ceramic, Monolithic: 47 pF, \pm 2%, 100 V	1	150-100-NPO-470G	51642	
C45	Same as C7				

REF DESIG PREFIX A1A8A1

REF DESIG	DESCRIPTION	QTY PER ASSY	MANUFACTURER'S PART NO.	MFR. CODE	RECM VENDOR
CR1	Diode	1	1N4005	80131	
CR2	Diode, Varicap: 26 pF-32 pF at 3 V	4	KV3901	52673	
CR3 Thru CR5	Same as CR2				
CR6	Diode	5	1N4449	80131	
CR7 Thru CR10	Same as CR6				
DL1A	Delay Line	2	281213-1	14632	
DL1B	Same as DL1A				
DL1C	Delay Line	1	281213-3	14632	
L1	Coil, Fixed: 2.2 μ H, 10%	2	1025-28 (75084-4)	99800	
L2	Coil, Fixed: 1.2 μ H, 10%	1	1025-22 (75084-1)	99800	
L3	Same as L1				
L4	Coil, Fixed: 47 μ H, 10%	1	1025-60 (75085-3)	99800	
L5	Coil, Fixed, Molded: 4.7 μ H, 10%	1	1025-36 (75084-8)	99800	
Q1	Transistor	1	U310	17856	
R1	Resistor, Fixed, Film: 4.7 Ω , 5%, 1/4 W	2	CF1/4-4.7 OHMS/J	09021	
R2	Resistor, Fixed, Film: 2.7 k Ω , 5%, 1/4 W	1	CF1/4-2.7K/J	09021	
R3	Resistor, Fixed, Film: 2.7 Ω , 5%, 1/4 W	1	CF1/4-2.7 OHMS/J	09021	
R4	Resistor, Fixed, Film: 5.11 k Ω , 1%, 1/10 W	1	RN55C5111F	81349	
R5	Resistor, Fixed, Film: 7.5 k Ω , 1%, 1/10 W	1	RN55C7501F	81349	
R6	Resistor, Fixed, Film: 10 Ω , 5%, 1/4 W	2	CF1/4-10 OHMS/J	09021	
R7	Resistor, Fixed, Film: 27 k Ω , 5%, 1/4 W	2	CF1/4-27K/J	09021	
R8	Resistor, Fixed, Film: 27 k Ω , 5%, 1/8 W	1	CF1/8-27K/J	09021	
R9	Resistor, Fixed, Film: 11 k Ω , 1%, 1/10 W	1	RN55C1102F	81349	
R10	Resistor, Fixed, Film: 11.5 k Ω , 1%, 1/10 W	1	RN55C1152F	81349	
R11	Resistor, Fixed, Film: 7.5 k Ω , 1%, 1/10 W	1	RN55C7501F	81349	
R12	Resistor, Fixed, Film: 13.3 k Ω , 1%, 1/10 W	1	RN55C1332F	81349	
R13	Resistor, Fixed, Film: 15 k Ω , 1%, 1/10 W	1	RN55C1502F	81349	
R14	Resistor, Fixed, Film: 3.83 k Ω , 1%, 1/10 W	1	RN55C3831F	81349	
R15	Resistor, Fixed, Film: 5.62 k Ω , 1%, 1/10 W	1	RN55C5621F	81349	
R16	Resistor, Fixed, Film: 221 Ω , 1%, 1/10 W	1	RN55C2210F	81349	
R17	Resistor, Fixed, Film: 47 Ω , 5%, 1/4 W	1	CF1/4-47 OHMS	09021	
R18	Resistor, Fixed, Film: 3.9 k Ω , 5%, 1/4 W	1	CF1/4-3.9K/J	09021	
R19	Resistor, Fixed, Film: 1.5 k Ω , 5%, 1/4 W	1	CF1/4-1.5K/J	09021	
R20	Resistor, Fixed, Film: 1.0 k Ω , 5%, 1/4 W	3	CF1/4-1K/J	09021	
R21	Resistor, Fixed, Film: 10 k Ω , 5%, 1/4 W	1	CF1/4-10K/J	09021	
R22	Resistor, Fixed, Film: 470 Ω , 5%, 1/4 W	3	CF1/4-470 OHMS/J	09021	
R23	Resistor, Fixed, Film: 68 Ω , 5%, 1/4 W	1	CF1/4-68 OHMS/J	09021	
R24	Same as R6				
R25	Resistor, Fixed, Film: 100 Ω , 5%, 1/4 W	2	CF1/4-100 OHMS/J	09021	

REF DESIG PREFIX A1A8A1

REF DESIG	DESCRIPTION	QTY PER ASSY	MANUFACTURER'S PART NO.	MFR. CODE	RECM VENDOR
R26	Resistor, Fixed, Film: 47 k Ω , 5%, 1/4 W	1	CF1/4-47K/J	09021	
R27	Resistor, Fixed, Film: 6.8 Ω , 5%, 1/4 W	2	CF1/4-6.8 OHMS/J	09021	
R28	Same as R27				
R29	Resistor, Fixed, Film: 22 Ω , 5%, 1/4 W	2	CF1/4-22 OHMS/J	09021	
R30	Same as R1				
R31	Resistor, Fixed, Film: 300 Ω , 5%, 1/4 W	2	CF1/4-300 OHMS/J	09021	
R32	Resistor, Fixed, Film: 18 Ω , 5%, 1/4 W	1	CF1/4-18 OHMS/J	09021	
R33	Same as R31				
R34	Same as R29				
R35	Resistor, Fixed, Film: 4.75 k Ω , 1%, 1/10W	1	RN55C4751F	81349	
R36	Resistor, Fixed, Film: 7.5 k Ω , 5%, 1/4 W	1	CF1/4-7.5K/J	09021	
R37	Resistor, Fixed, Film: 10 k Ω , 1%, 1/10 W	1	RN55C1002F	81349	
R38	Same as R25				
R39	Resistor, Fixed, Film: 9.09 k Ω , 1%, 1/10 W	1	RN55C9091F	81349	
R40	Resistor, Fixed, Film: 2.2 k Ω , 5%, 1/4 W	5	CF1/4-2.2K/J	09021	
R41	Resistor, Fixed, Film: 47.5 k Ω , 1%, 1/10 W	1	RN55C4752F	81349	
R42	Same as R22				
R43	Same as R22				
R44	Resistor, Trimmer, Film: 5 k Ω , 10%, 1/2 W	1	62PAR5K	73138	
R45	Resistor, Fixed, Film: 909 Ω , 1%, 1/10 W	1	RN55C9090F	81349	
R46	Same as R7				
R47	Same as R20				
R48	Same as R20				
R49	Resistor, Fixed, Film: 470 k Ω , 5%, 1/4 W	2	CF1/4-470K/J	09021	
R50	Same as R49				
R51	Same as R40				
Thru R54	Same as R40				
T1	Transformer	2	T2-1T	15542	
T2	Same as T1				
U1	Integrated Circuit	1	MC1723CP	04713	
U2	Integrated Circuit	1	MWA120	04713	
U3	Amplifier RF	2	MWA130	04713	
U4	Same as U3				
U5	Mixer, Balanced	1	TAK-3H	15542	
U6	Amplifier	1	QBH-137	55027	
U7	Voltage Regulator	1	UA78M05HC	07263	
U8	Integrated Circuit	1	MC145146P	04713	
U9	Integrated Circuit	1	SP8690B/DG	52648	
U10	Integrated Circuit	1	MC34002P	04713	
U11	Integrated Circuit	1	LM336Z-5.0	27014	
U12	Integrated Circuit	1	LF398AN	27014	

REF DESIG PREFIX A1A8A1

REF DESIG	DESCRIPTION	QTY PER ASSY	MANUFACTURER'S PART NO.	MFR. CODE	RECM VENDOR
U13	Integrated Circuit	1	LT1007CN8	4W715	
U14	Integrated Circuit	1	MM74HC32N	27014	
U15	Integrated Circuit	2	MM74HC74N	27014	
U16	Integrated Circuit	1	MM74HC04N	27014	
U17	Same as U15				
U18	Integrated Circuit	1	MM74HC132N	27014	
Y1	Crystal, Quartz	1	CR64U 5.000 MHz	80058	

5.5.1.7.2 Type 796541-1 Second LO/Second Converter Assembly REF DESIG PREFIX A1A8A2

REF DESIG	DESCRIPTION	QTY PER ASSY	MANUFACTURER'S PART NO.	MFR. CODE	RECM VENDOR
C1	Revision C Not Used				
C2	Capacitor, Electrolytic, Tantalum: 4.7 μ F, 20%, 35 V	3	196D475X0035JE3	56289	
C3	Capacitor, Ceramic, Monolithic: 1000 pF, \pm 2%, 100 V	7	150-100-NPO-102G	51642	
C4	Capacitor, Cermaic, Monolithic: 27 pF, \pm 2%, 100 V	1	150-100-NPO-270G	51642	
C5	Capacitor, Ceramic, Monolithic: 68 pF, \pm 2%, 100 V	1	200-100-NPO-680G	51642	
C6	Capacitor, Ceramic, Monolithic: 100 pF, \pm 2%, 100 V	1	200-100-NPO-101G	51642	
C7	Capacitor, Ceramic, Monolithic: 15 pF \pm 2%, 100 V	2	100-100-NPO-150G	51642	
C8	Capacitor, Ceramic, Monolithic: 47 pF, \pm 2%, 100 V	1	150-100-NPO-470G	51642	
C9	Same as C7				
C10	Same as C2				
C11 Thru C13	Same as C3				
C14	Same as C2				
C15 Thru C17	Same as C3				
L1	Coil, Variable: 0.135-0.165 μ H	1	558-7107-03	71279	
L2	Coil, Fixed, Molded: .1 μ H	2	1025-94	99800	
L3	Same as L2				
Q1	Transistor	1	U310	17856	
R1	Resistor, Fixed, Film: 47 Ω , 5%, 1/4 W	3	CF1/4-47 OHMS/J	09021	
R2	Resistor, Fixed, Film: 10 Ω , 5%, 1/4 W	4	CF1/4-10 OHMS/J	09021	
R3	Resistor, Fixed, Film: 220 Ω , 5%, 1/4 W	1	CF1/4-220 OHMS/J	09021	
R4	Resistor, Fixed, Film: 300 Ω , 5%, 1/4 W	4	CF1/4-300 OHMS/J	09021	
R5	Resistor, Fixed, Film: 18 Ω , 5%, 1/4 W	2	CF1/4-18 OHMS/J	09021	
R6	Same as R4				
R7	Resistor, Fixed, Film: 68 Ω , 5%, 1/4 W	1	CF1/4-68 OHMS/J	09021	
R8	Same as R2				
R9	Same as R1				
R10	Same as R1				
R11	Same as R2				
R12	Same as R2				
R13	Same as R4				
R14	Same as R5				
R15	Same as R4				
R16	Resistor, Fixed, Film: 47 Ω , 5%, 1/8 W	1	841296-33	14632	
T1	Transformer	2	T2-1T	15542	
T2	Same as T1				
U1	Amplifier RF	1	MWA-120	04713	
U2	Amplifier RF	2	MWA-130	04713	
U3	Same as U2				
U4	Mixer, Balanced	1	TAK-3H	15542	

REF DESIG PREFIX A1A8A2

REF DESIG	DESCRIPTION	QTY PER ASSY	MANUFACTURER'S PART NO.	MFR. CODE	RECM VENDOR
W1	Wire	1	281213-1	14632	
Y1	Crystal, Quartz	1	CR56/U 86.000 MHz	80058	
Z1	Balun	1	281179-1	14632	

5.5.1.7.3 Type 796542-1 Second IF/RBW (10 kHz) Assembly

REF DESIG PREFIX A1A8A3

REF DESIG	DESCRIPTION	QTY PER ASSY	MANUFACTURER'S PART NO.	MFR. CODE	RECM VENDOR
	Revision A				
C1	Capacitor, Ceramic, Disc: .1 μ F, 20%, 50 V	9	34475-1	14632	
C2	Same as C1				
C3	Same as C1				
C4	Capacitor, Ceramic, Monolithic: 27 pF, \pm 2%, 100 V	2	150-100-NPO-270G	51642	
C5	Capacitor, Ceramic, Monolithic: 6.8 pF, \pm 2%, 100 V	2	100-100-NPO-689C	51642	
C6	Same as C5				
C7	Same as C4				
C8					
Thru C10	Same as C1				
C11	Capacitor, Ceramic, Monolithic: 20 pF, \pm 2%, 100 V	2	100-100-NPO-200G	51642	
C12	Capacitor, Ceramic, Monolithic: 15 pF, \pm 2%, 100 V	2	100-100-NPO-150G	51642	
C13	Same as C12				
C14	Same as C11				
C15					
Thru C17	Same as C1				
C18	Capacitor, Ceramic, Disc: .47 μ F, 20%, 50 V	1	34452-1	14632	
CR1	Diode	2	5082-3188	28480	
CR2	Same as CR1				
FL1	Filter, Crystal	2	5261/UMB	25120	
FL2	Same as FL1				
L1	Coil, Fixed, Molded: 15 μ H, 10%	6	1025-48 (75084-14)	99800	
L2	Same as L1				
L3	Coil, Variable: 5.04 - 6.16 μ H	4	558-7107-22	71279	
L4	Same as L3				
L5	Same as L1				
L6	Same as L1				
L7	Same as L3				
L8	Same as L3				
L9	Same as L1				
L10	Same as L1				
Q1	Transistor	1	2N2907/JAN	81350	
R1	Resistor, Fixed, Film: 390 Ω , 5%, 1/4 W	2	CF1/4-390 OHMS/J	09021	
R2	Resistor, Fixed, Film: 56 Ω , 5%, 1/4 W	2	CF1/4-56 OHMS/J	09021	
R3	Same as R2				
R4	Same as R1				
R5	Resistor, Fixed, Film: 4.7 k Ω , 5%, 1/4 W	1	CF1/4-4.7K/J	09021	
R6	Resistor, Fixed, Film: 470 Ω , 5%, 1/4 W	1	CF1/4-470 OHMS/J	09021	
R7	Resistor, Fixed, Film: 300 Ω , 5%, 1/4 W	2	CF1/4-300 OHMS/J	09021	
R8	Same as R7				
R9	Resistor, Fixed, Film: 18 Ω , 5%, 1/4 W	1	CF1/4-18 OHMS/J	09021	

REF DESIG PREFIX A1A8A3

REF DESIG	DESCRIPTION	QTY PER ASSY	MANUFACTURER'S PART NO.	MFR. CODE	RECM VENDOR
U1	Amplifier	2	MWA-220	04713	
U2	Same as U1				
U3	Voltage Regulator: +5 V	1	UA78M05HC	07263	
VR1	Diode, Zener: 3.3 V	1	1N746A	80131	

5.5.1.8 Type 796790-1 Second IF/2 kHz RBW Assembly (Optional)

REF DESIG PREFIX A1A9

REF DESIG	DESCRIPTION	QTY PER ASSY	MANUFACTURER'S PART NO.	MFR. CODE	RECM VENDOR
A1	Revision A Second IF/2 kHz RBW, PC Board	1	381939-1	14632	
C1	Filter	4	4101-000	59660	
C2 Thru C4	Same as C1				

REPLACEMENT PARTS LIST

WJ-9205

5.5.1.8.1 Part 381939-1 Second IF/2 kHz RBW,
PC Board

REF. DESIG PREFIX A1A9A1

REF DESIG	DESCRIPTION	QTY PER ASSY	MANUFACTURER'S PART NO.	MFR. CODE	RECM VENDOR
	Revision B				
C1	Capacitor, Electrolytic, Tantalum: 4.7 μ F, 20%, 35 V	1	196D475X0035JE3	56289	
C2	Capacitor, Ceramic, Disc: .01 μ F, 20%, 50 V	9	34453-1	14632	
C3	Capacitor, Ceramic, Disc: 1 μ F, 20%, 50 V	2	8131-050-651-105M	59660	
C4	Same as C3				
C5 Thru C9	Same as C2				
C10	Capacitor, Ceramic, Disc: 1 μ F, 20%, 50 V	1	34475-1	14632	
C11 Thru C13	Same as C2				
CR1	Diode	2	5082-3188	28480	
CR2	Same as CR1				
FL1	Filter, Bandpass	1	92518	14632	
L1	Coil, Fixed, Molded: 15 μ H, 10%	3	1025-48 (75084-14)	99800	
L2	Not Used				
L3	Same as L1				
L4	Same as L1				
Q1	Transistor	1	2N2219A	04713	
R1	Resistor, Fixed, Film: 4.7 Ω , 5%, 1/4 W	2	CF1/4-4.7 OHMS/J	09021	
R2	Resistor, Fixed, Film: 2.2 k Ω , 5%, 1/4 W	2	CF1/4-2.2K/J	09021	
R3	Resistor, Fixed, Film: 1.0 k Ω , 5%, 1/4 W	1	CF1/4-1K/J	09021	
R4	Resistor, Fixed, Film: 220 k Ω , 5%, 1/4 W	1	CF1/4-220K/J	09021	
R5	Same as R1				
R6	Resistor, Fixed, Film: 330 Ω , 5%, 1/4 W	1	CF1/4-330 OHMS/J	09021	
R7	Same as R6				
R8	Resistor, Fixed, Film: 300 Ω , 5%, 1/4 W	1	CF1/4-300 OHMS/J	09021	
R9	Resistor, Fixed, Film: 4.7 Ω , 5%, 1/4 W	1	CF1/4-4.7 OHMS/J	09021	
R10	Resistor, Fixed, Film: 10 k Ω , 5%, 1/4 W	1	CF1/4-10K/J	09021	
R11	Resistor, Fixed, Film: 150 Ω , 5%, 1/4 W	1	CF1/4-150 OHMS/J	09021	
R12	Resistor, Fixed, Film: 130 Ω , 5%, 1/4 W	1	CF1/4-130 OHMS/J	09021	
R13	Resistor, Fixed, Film: 30 Ω , 5%, 1/4 W	1	CF1/4-30 OHMS/J	09021	
R14	Resistor, Fixed, Film: 180 Ω , 5%, 1/4 W	2	CF1/4-180 OHMS/J	09021	
R15	Same as R2				
R16	Same as R14				
R17	Resistor, Fixed, Film: 39 Ω , 5%, 1/4 W	1	CF1/4-39 OHMS/J	09021	
R18	Resistor, Fixed, Film: 18 Ω , 5%, 1/4 W	1	CF1/4-18 OHMS/J	09021	
R19	Resistor, Trimmer, Film: 50 Ω , 10%, 1/2 W	1	62PAR50	73138	
R20	Resistor, Fixed, Film: 240 Ω , 5%, 1/4 W	1	CF1/4-240 OHMS/J	09021	
U1	Integrated Circuit	1	TL081CP	01295	
U2	Amplifier	1	MWA-220	04713	
U3	Amplifier, RF	1	MWA120	04713	

5.5.1.9 **Type 796577-1 LOG IF Amplifier/Detector Assembly** REF DESIG PREFIX A1A10

REF DESIG	DESCRIPTION	QTY PER ASSY	MANUFACTURER'S PART NO.	MFR. CODE	RECM VENDOR
A1	Revision A LOG IF/Detector Assembly	1	796506-2	14632	
C1	Not Used				
C2	Not Used				
C3	Capacitor, Ceramic, Feedthru: 1000 pF, 500 V	4	54-794-009-102W	33095	
C4	Same as C3				
C5	Same as C3				
C6	Not Used				
C7	Same as C3				
P1	Receptacle Assembly	1	66527-010	22526	

5.5.1.9.1 Type 796506-2 LOG IF/Detector Assembly

REF DESIG PREFIX A1A10A1

REF DESIG	DESCRIPTION	QTY PER ASSY	MANUFACTURER'S PART NO.	MFR. CODE	RECM VENDOR
	Revision D1				
C1	Capacitor, Ceramic, Disc: .01 μ F, 20%, 50 V	15	34453-1	14632	
C2	Capacitor, Ceramic, Monolithic: 150 pF, \pm 2%, 100 V	1	150-100-NPO-151G	51642	
C3	Capacitor, Ceramic, Monolithic: 360 pF, \pm 2%, 100 V	1	150-100-NPO-361G	51642	
C4	Same as C1				
C5	Capacitor, Ceramic, Monolithic: 75 pF, \pm 2%, 100 V	1	200-100-NPO-750G	51642	
C6 Thru C9	Same as C1				
C10	Capacitor, Electrolytic, Tantalum: 4.7 μ F, 20%, 35V	8	196D475X0035JE3	56289	
C11	Capacitor, Ceramic, Disc: .022 μ F, 10%, 100 V	7	CK06BX223K	81349	
C12	Same as C1				
C13	Capacitor, Ceramic, Monolithic: 120 pF, \pm 2%, 100 V	2	200-100-NPO-121G	51642	
C14	Same as C1				
C15	Same as C11				
C16	Same as C1				
C17	Same as C11				
C18	Same as C1				
C19	Same as C10				
C20	Same as C11				
C21	Same as C1				
C22	Same as C13				
C23	Same as C1				
C24	Same as C11				
C25	Same as C1				
C26	Same as C10				
C27	Same as C11				
C28	Same as C1				
C29	Same as C11				
C30	Same as C1				
C31	Capacitor, Ceramic, Monolithic: 1500 pF, \pm 2%, 100 V	2	150-100-NPO-152G	51642	
C32	Same as C31				
C33	Same as C10				
C34	Same as C10				
C35	Capacitor, Ceramic, Monolithic: 1000 pF, \pm 2%, 100 V	1	150-100-NPO-102G	51642	
C36 Thru C38	Same as C10				
CR1	Diode	1	1N4449	80131	
L1	Coil, Fixed, Molded: 0.82 μ H, 10%	1	1025-18	99800	
L2	Coil, Fixed: 0.39 μ H, 10%	1	1025-10 (75083-8)	99800	
L3	Coil, Variable: 2.43-2.97 μ H	1	558-7107-18	71279	
L4	Coil, Fixed: 18 μ H, 10%	3	1025-50 (75084-15)	99800	

REF DESIG PREFIX A1A10A1

REF DESIG	DESCRIPTION	QTY PER ASSY	MANUFACTURER'S PART NO.	MFR. CODE	RECM VENDOR
L5	Same as L4				
L6	Coil, Variable: 1.98-2.42 μ H	2	558-7107-17	71279	
L7	Same as L4				
L8	Same as L6				
Q1	Transistor	1	U310	17856	
Q2	Transistor	1	2N2102	80131	
R1	Resistor, Fixed, Film: 1.5 k Ω , 5%, 1/4 W	3	CF1/4-1.5K/J	09021	
R2	Resistor, Variable, Film: 200 Ω , 10%, 1/2 W	1	62PAR200	73138	
R3	Resistor, Fixed, Film: 100 Ω , 5%, 1/4 W	2	CF1/4-100 OHMS/J	09021	
R4	Resistor, Fixed, Film: 10 Ω , 5%, 1/4 W	8	CF1/4-10 OHMS/J	09021	
R5	Resistor, Fixed, Film: 1.0 k Ω , 5%, 1/4 W	7	CF1/4-1K/J	09021	
R6	Same as R1				
R7	Same as R4				
R8	Same as R5				
R9	Resistor, Fixed, Film: 47 Ω , 5%, 1/4 W	4	CF1/4-47 OHMS/J	09021	
R10	Same as R4				
R11	Same as R5				
R12	Same as R9				
R13	Same as R4				
R14	Same as R5				
R15	Same as R1				
R16	Same as R4				
R17	Same as R5				
R18	Same as R9				
R19	Same as R4				
R20	Same as R5				
R21	Same as R9				
R22	Same as R4				
R23	Same as R5				
R24	Resistor, Fixed, Film: 4.7 k Ω , 5%, 1/4 W	2	CF1/4-4.7K/J	09021	
R25	Same as R3				
R26	Resistor, Fixed, Film: 10 k Ω , 1%, 1/10 W	2	RN55C1002F	81349	
R27	Same as R26				
R28	Resistor, Fixed, Film: 18.2 k Ω , 1%, 1/10 W	2	RN55C1822F	81349	
R29	Same as R28				
R30	Resistor, Trimmer, Film: 10 k Ω , 10%, 1/2 W	1	62PAR10K	73138	
R31	Resistor, Fixed, Film: 10 k Ω , 5%, 1/10 W	1	CF1/4-10K/J		
R32	Resistor, Fixed, Film: 51 k Ω , 5%, 1/4 W	1	CF1/4-51K/J	09021	
R33	Resistor, Fixed, Film: 5.1 k Ω , 5%, 1.4 W	1	CF1/4-5.1K/J	09021	
R34	Resistor, Trimmer, Film: 100 Ω , 10%, 1/2 W	1	62PAR100	73138	
R35	Same as R24				

REPLACEMENT PARTS LIST

WJ-9205

REF DESIG PREFIX A1A10A1

REF DESIG	DESCRIPTION	QTY PER ASSY	MANUFACTURER'S PART NO.	MFR. CODE	RECM VENDOR
R36	Resistor, Fixed, Film: 100 k Ω , 5%, 1/4 W	2	CF1/4-100K/J	09021	
R37	Same as R36				
R38	Resistor, Fixed, Film: 620 Ω , 5%, 1/4 W	1	CF1/4-620 OHMS/J	09021	
R39	Resistor, Fixed, Film: 100 k Ω , 1%, 1/10 W	1	RN55C1003F	81349	
R40	Resistor, Fixed, Film: 232 Ω , 1%, 1/10 W	1	RN55C2320F	81349	
R41	Resistor, Fixed, Film: 402 k Ω , 1%, 1/10 W	1	RN55C4023F	81349	
R42	Not Used				
R43	Resistor, Fixed, Film: 2.0 k Ω , 1%, 1/10 W	1	RN55C2001F	81349	
R44	Resistor, Fixed, Film: 12.1 k Ω , 1%, 1/10 W	1	RN55C1212F	81349	
R45	Resistor, Fixed, Film: 2.7 Ω , 5%, 1/4 W	2	CF1/4-2.7 OHMS/J	09021	
R46	Same as R45				
R47	Same as R4				
RA1	Heatsink	1	2225B	13103	
U1	Integrated Circuit	7	SL521C/CM	52648	
U2					
Thru U7	Same as U1				
U8	Integrated Circuit	2	TL082ACP	01295	
U9	Same as U8				
U10	Integrated Circuit: VR +6 V	1	MC1723CP	04713	

5.5.2 TYPE 796782-1 HIGH VOLTAGE POWER
SUPPLY/VIDEO

REF DESIG PREFIX A2

REF DESIG	DESCRIPTION	QTY PER ASSY	MANUFACTURER'S PART NO.	MFR. CODE	RECM VENDOR
A1	Revision B1 High Voltage Power Supply/Deflection Amplifier Assembly	1	796545-1	14632	
A1P1	Socket CRT	1	3B14	71785	
V1	Tube, CRT	1	481445-1	14632	

5.5.2.1 Type 796545-1 High Voltage Power Supply/
Deflection Amplifier Assembly

REF DESIG PREFIX A2A1

REF DESIG	DESCRIPTION	QTY PER ASSY	MANUFACTURER'S PART NO.	MFR. CODE	RECM VENDOR
	Revision B1				
C1	Capacitor, Electrolytic, Tantalum: 18 μ F, 10%, 20 V	9	196D186X9020KE3	56289	
C2 Thru C4	Same as C1				
C5	Capacitor, Ceramic, Monolithic: 5100 pF, \pm 2%, 100 V	1	300-100-NPO-512G	51642	
C6	Capacitor, Ceramic, Disc: .47 μ F, 20%, 50 V	2	34452-1	14632	
C7	Same as C6				
C8 Thru C10	Same as C1				
C11	Capacitor, Ceramic, Disc: .1 μ F, 20%, 50 V	1	34475-1	14632	
C12	Capacitor, Ceramic, Disc: .01 μ F, 20%, 50 V	1	34453-1	14632	
C13	Same as C1				
C14	Same as C1				
C15	Capacitor, Ceramic, Disc: 2200 pF, 20%, 3 KVDC	4	30GA-D22	56289	
C16	Same as C15				
C17	Capacitor, Electrolytic, Tantalum: 27 μ F, 10%, 35 V	1	196D276X9035TE4	56289	
C18	Same as C15				
C19	Same as C15				
C20	Capacitor, Ceramic, Disc: .01 μ F, 20%, 3 KVDC	1	30GAS10	56289	
C21	Capacitor, Myl, Dipped: .22 μ F, 20%, 400 V	1	B32234B6224M	25088	
C22	Capacitor, Ceramic, Disc: .01 μ F, 10%, 200 V	1	CK06BX103K	81349	
C23	Capacitor, Ceramic, Monolithic: 100 pF, \pm 2%, 100 V	2	200-100-NPO-101G	51642	
C24	Same as C23				
CR1	Diode	2	MR851	04713	
CR2	Same as CR1				
CR3	Diode, Rectifier	5	VA30X	8K838	
CR4 Thru CR7	Same as CR3				
L1	Inductor	2	5258	76493	
L2	Same as L1				
P1	Connector, Receptacle	1	609-2030	15912	
Q1	Transistor	2	IRF-822	81483	
Q2	Same as Q1				
Q3	Transistor	3	2N3904	80131	
Q4	Transistor	1	TIP30	04713	
Q5	Transistor	4	2N3439	80131	
Q6	Same as Q5				
Q7	Same as Q3				
Q8	Same as Q5				
Q9	Same as Q5				
Q10	Same as Q3				

REF DESIG PREFIX A2A1

REF DESIG	DESCRIPTION	QTY PER ASSY	MANUFACTURER'S PART NO.	MFR. CODE	RECM VENDOR
R1	Resistor, Fixed, Film: 1.5 k Ω , 5%, 1/4 W	2	CF1/4-1.5K/J	09021	
R2	Same as R1				
R3	Resistor, Fixed, Film: 3.65 k Ω , 1%, 1/10 W	1	RN55C3651F	81349	
R4	Resistor, Fixed, Film: 22.1 Ω , 1%, 1/10 W	1	RN55D22R1F	81349	
R5	Resistor, Fixed, Film: 1.0 k Ω , 5%, 1/4 W	4	CF1/4-1K/J	09021	
R6	Same as R5				
R7	Resistor, Fixed, Film: 27 k Ω , 5%, 1/4 W	2	CF1/4-27K/J	09021	
R8	Same as R5				
R9	Resistor, Fixed, Film: 330 Ω , 5%, 1/4 W	1	CF1/4-330 OHMS/J	09021	
R10	Same as R5				
R11	Resistor, Fixed, Film: 22 k Ω , 5%, 1/4 W	1	CF1/4-22K/J	09021	
R12	Resistor, Fixed, Film: 2.7M, 5%, 1/4 W	8	CF1/4-2.7M/J	09021	
R13 Thru R19	Same as R12				
R20	Resistor, Trimmer, Film: 20 k Ω , 10%, 1/2 W	2	62PAR20K	73138	
R21	Resistor, Fixed, Film: 43 k Ω , 5%, 1/4 W	1	CF1/4-43K/J	09021	
R22	Resistor, Fixed, Film: 47 k Ω , 5%, 1/4 W	4	CF1/4-47K/J	09021	
R23	Resistor, Variable, Composition: 500 k Ω , 10%, 1 W	1	72M1N048S504U	01121	
R24	Resistor, Fixed, Film: 1.5 M, 5%, 1/4 W	1	CF1/4-1.5M/J	09021	
R25	Resistor, Trimmer, Film: 1 M, 10%, 1/2 W	1	62PAR1M	73138	
R26	Resistor, Fixed, Film: 1.0 M, 5%, 1/4 W	5	CF1/4-1M/J	09021	
R27 Thru R30	Same as R26				
R31	Resistor, Fixed, Film: 620 Ω , 5%, 1/4 W	2	CF1/4-620 OHMS/J	09021	
R32	Same as R31				
R33	Resistor, Fixed, Film: 10 k Ω , 1%, 1/10 W	8	RN55C1002F	81349	
R34 Thru R36	Same as R33				
R37	Resistor, Trimmer, Film: 10 k Ω , 10%, 1/2 W	7	62PAR10K	73138	
R38	Resistor, Fixed, Film: 2.7 k Ω , 5%, 1/4 W	1	CF1/4-2.7K/J	09021	
R39	Same as R37				
R40	Resistor, Fixed, Film: 270 k Ω , 5%, 1/4 W	3	CF1/4-270K/J	09021	
R41	Resistor, Fixed, Film: 51.1 k Ω , 1%, 1/10 W	2	RN55C5112F	81349	
R42	Resistor, Fixed, Film: 5.11 k Ω , 1%, 1/10 W	1	RN55C5111F	81349	
R43	Same as R20				
R44	Resistor, Fixed, Film: 10 k Ω , 5%, 1/4 W	2	CF1/4-10K/J	09021	
R45	Same as R37				
R46	Resistor, Fixed, Film: 470 k Ω , 5%, 1/4 W	1	CF1/4-470K/J	09021	
R47	Resistor, Fixed, Film: 130 k Ω , 5%, 1/4 W	1	CF1/4-130K/J	09021	
R48	Resistor, Fixed, Film: 100 k Ω , 5%, 1/4 W	3	CF1/4-100K/J	09021	
R49	Same as R48				

REPLACEMENT PARTS LIST

WJ-9205

REF DESIG PREFIX A2A1

REF DESIG	DESCRIPTION	QTY PER ASSY	MANUFACTURER'S PART NO.	MFR. CODE	RECM VENDOR
R50	Resistor, Trimmer, Film: 500 k Ω , 10%, 1/2 W	1	62PAR500K	73138	
R51	Resistor, Fixed, Film: 3.01 k Ω , 1%, 1/10 W	2	RN55C3011F	81349	
R52	Same as R51				
R53	Same as R33				
R54	Resistor, Fixed, Film: 4.75 k Ω , 1%, 1/10 W	2	RN55C4751F	81349	
R55	Resistor, Fixed, Film: 1.82 k Ω , 1%, 1/10 W	1	RN55C1821F	81349	
R56	Same as R37				
R57	Resistor, Fixed, Film: 4.7 k Ω , 5%, 1/4 W	1	CF1/4-4.7K/J	09021	
R58	Same as R41				
R59	Same as R40				
R60	Same as R40				
R61	Same as R37				
R62	Same as R48				
R63	Same as R33				
R64	Same as R37				
R65	Same as R44				
R66	Resistor, Fixed, Film: 68 k Ω , 5%, 1/4 W	1	CF1/4-68K/J	09021	
R67	Same as R22				
R68	Same as R22				
R69	Same as R7				
R70	Resistor, Trimmer, Film: 100 k Ω , 10%, 1/2 W	2	62PAR100K	73138	
R71	Resistor, Fixed, Film: 1.5 k Ω , 1%, 1/10 W	2	RN55C1501F	81349	
R72	Same as R71				
R73	Resistor, Fixed, Film: 220 k Ω , 5%, 1/4 W	1	CF1/4-220K/J	09021	
R74	Same as R37				
R75	Same as R33				
R76	Same as R54				
R77	Resistor, Fixed, Film: 1.0 k Ω , 1%, 1/10 W	1	RN55C1001F	81349	
R78	Same as R33				
R79	Resistor, Fixed, Film: 20 k Ω , 1%, 1/10 W	1	RN55C2002F	81349	
R80	Same as R70				
R81	Same as R22				
T1	Transformer	1	381029-2	14632	
U1	Integrated Circuit	2	LM336Z-5.0	27014	
U2	Same as U1				
U3	Integrated Circuit	5	TL082ACP	01295	
U4	Integrated Circuit	1	SG3526N	04713	
U5	Same as U3				
U6	Same as U3				
U7	Integrated Circuit	1	DG303ACJ	17856	
U8	Same as U3				
U9	Same as U3				

**5.5.3 TYPE 796771-1 LOW VOLTAGE
POWER SUPPLY ASSEMBLY**

REF DESIG PREFIX A3

REF DESIG	DESCRIPTION	QTY PER ASSY	MANUFACTURER'S PART NO.	MFR. CODE	RECM VENDOR
	Revision B1				
C1	Capacitor, Ceramic, Disc: .01 μ F, 20%, 50 V	4	34453-1	14632	
C2	Capacitor, Electrolytic, Tantalum: 4.7 μ F, 20%, 35 V	4	196D475X0035JE3	56289	
C3	Same as C2				
C4	Same as C2				
C5 Thru C7	Same as C1				
C8	Capacitor, Electrolytic, Aluminum: 6800 μ F, -10 +30%, 25 V	4	ECE-T25R682SW	54473	
C9 Thru C11	Same as C8				
C12	Same as C2				
CR1	Diode	2	MR851	04713	
CR2	Same as CR1				
J1	Connector, Receptacle	1	09-72-2091	27264	
L1	Ferrite Choke	4	VK200-10-3B	02114	
L2 Thru L4	Same as L1				
R1	Resistor, Fixed, Film: 243 Ω , 1%, 1/10 W	1	RN55C2430F	81349	
R2	Resistor, Fixed, Film: 1.33 k Ω , 1%, 1/10 W	1	RN55C1331F	81349	
U1	Rectifier Assembly	1	KBL01	11711	
U2	Voltage Regulator: +15 V	1	LM340T-15	27014	
U3	Voltage Regulator: -15 V	1	LM320T-15	27014	
U4	Voltage Regulator: +5 V	1	LM340AT-5.0	27014	
U5	Voltage Regulator: +8 V	1	LM317T	27014	

5.5.4 TYPE 796539-1 KEYBOARD DISPLAY ASSEMBLY

REF DESIG PREFIX A4

REF DESIG	DESCRIPTION	QTY PER ASSY	MANUFACTURER'S PART NO.	MFR. CODE	RECM VENDOR
	Revision A				
C1	Capacitor, Electrolytic, Tantalum: 1.0 μ F, 10%, 35 V	1	CS13BF105K	81349	
C2	Capacitor, Ceramic, Disc: .01 μ F, 20%, 50 V	6	34453-1	14632	
C3 Thru C7	Same as C2				
C8	Capacitor, Ceramic, Disc: .1 μ F, 20%, 50 V	1	34475-1	14632	
DS1	Diode	1	HLMP-1301	28480	
DS2	Diode	1	HLMP-1503	28480	
P1	Connector, Plug	1	609-3401M	15912	
R1	Resistor, Fixed, Film: 470 Ω , 5%, 1/4 W	2	CF1/4-470 OHMS/J	09021	
R2	Same as R1				
S1 S2 Thru S5	Switch, Marked Same as S1	5	381035-1	14632	
S6 S7 Thru S10	Switch, Marked Same as S6	5	381035-2	14632	
S11	Switch, Marked	1	381035-3	14632	
S12	Switch, Marked	1	381035-4	14632	
S13	Switch, Marked	1	381035-5	14632	
U1 U2 Thru U4	Display, Alphanumeric Same as U1	4	HPDL-2416	28480	
U5	Integrated Circuit	1	MM74C923N	27014	

SECTION VI
SCHEMATIC DIAGRAMS

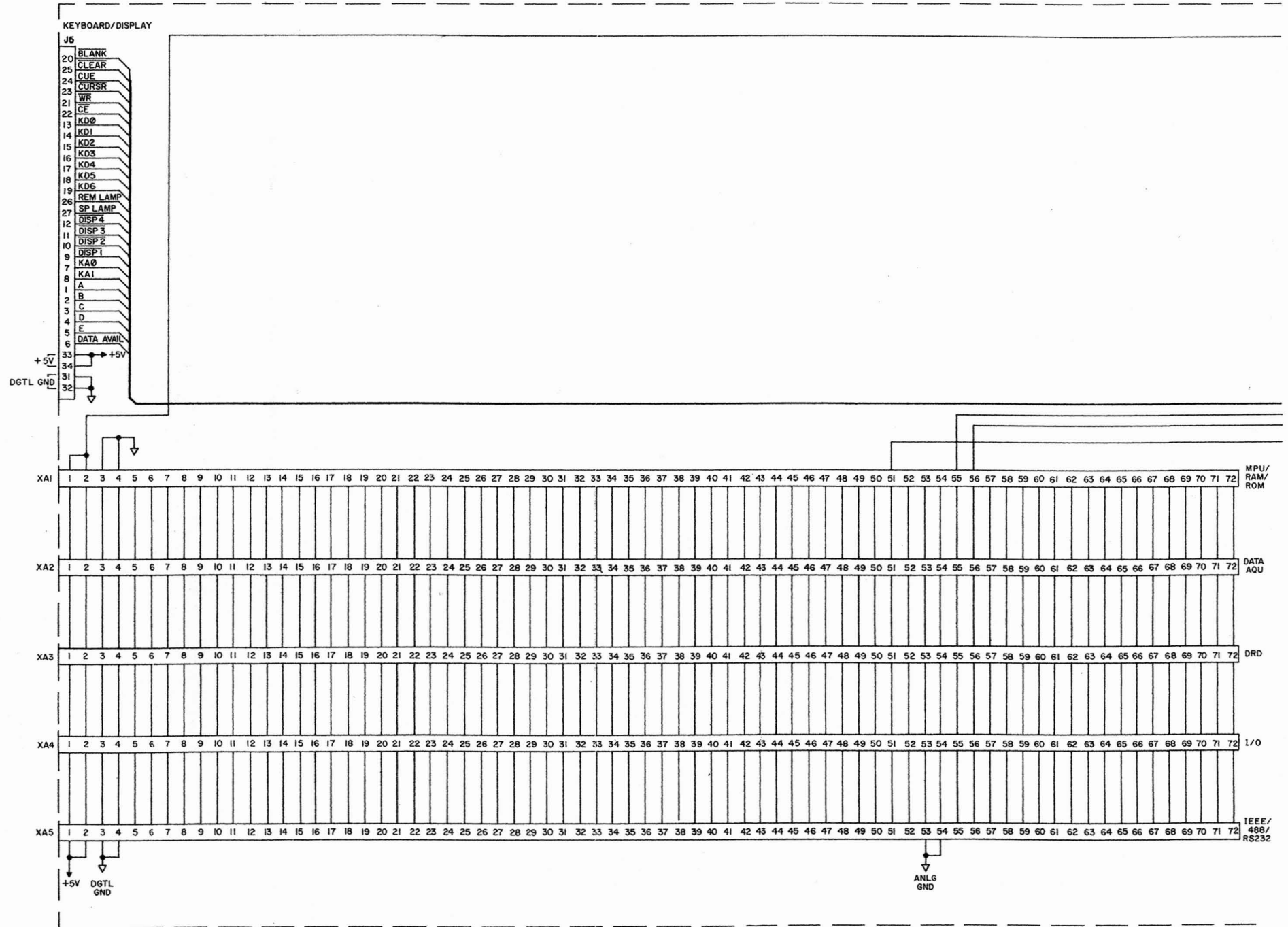

NOTES:
 I. UNLESS OTHERWISE SPECIFIED:
 a) CAPACITANCE IS IN μ F.
 b) RESISTANCE IS IN OHMS \pm

Figure 6-1. Type 796533-1, Motherboard Assembly (A1), Schematic Diagram 580534 (Sheet 1 of 2) (B)
 6-1

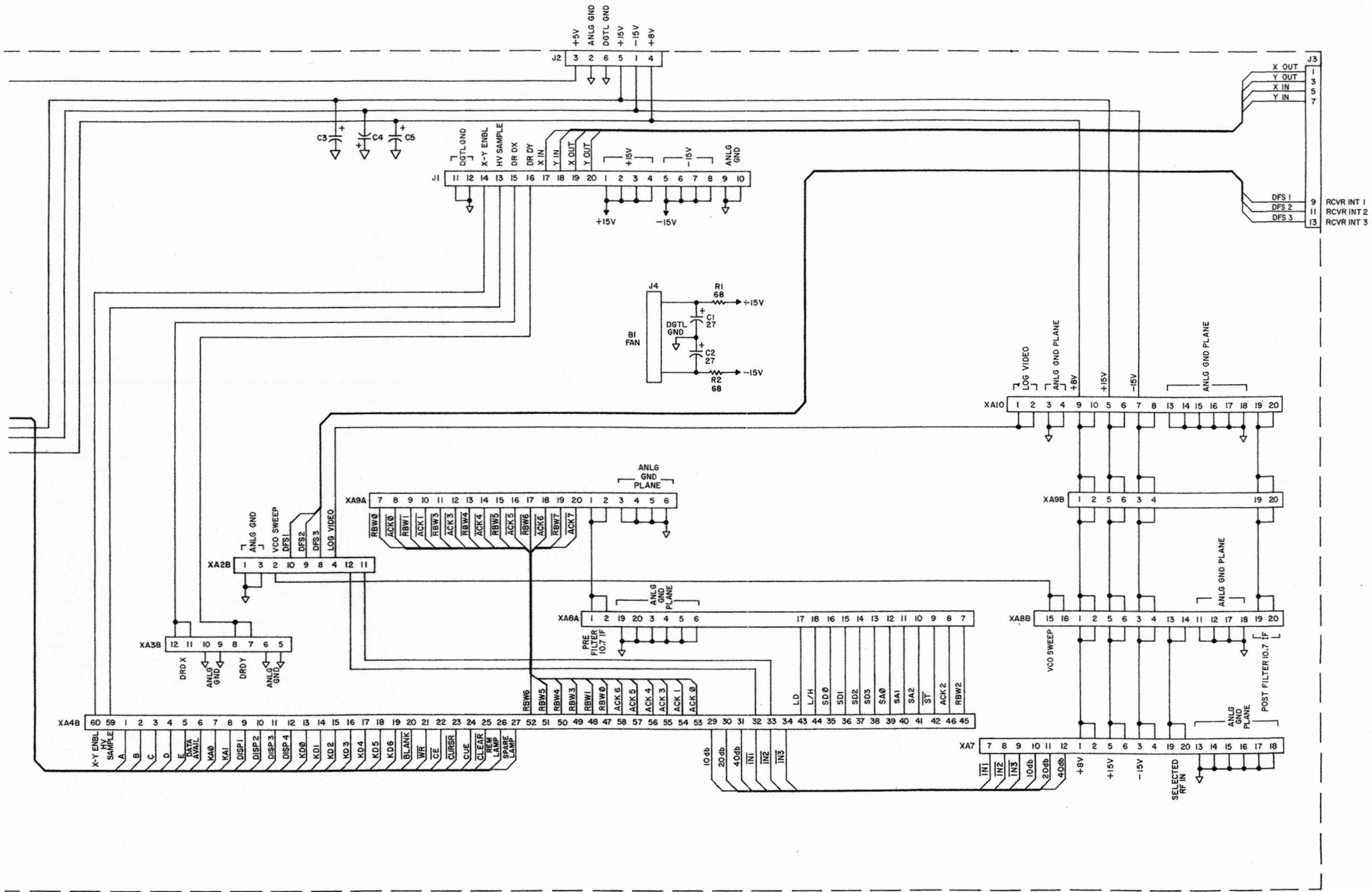

Figure 6-1. Type 796533-1, Motherboard Assembly (A1), Schematic Diagram 580534 (Sheet 2 of 2) (B)

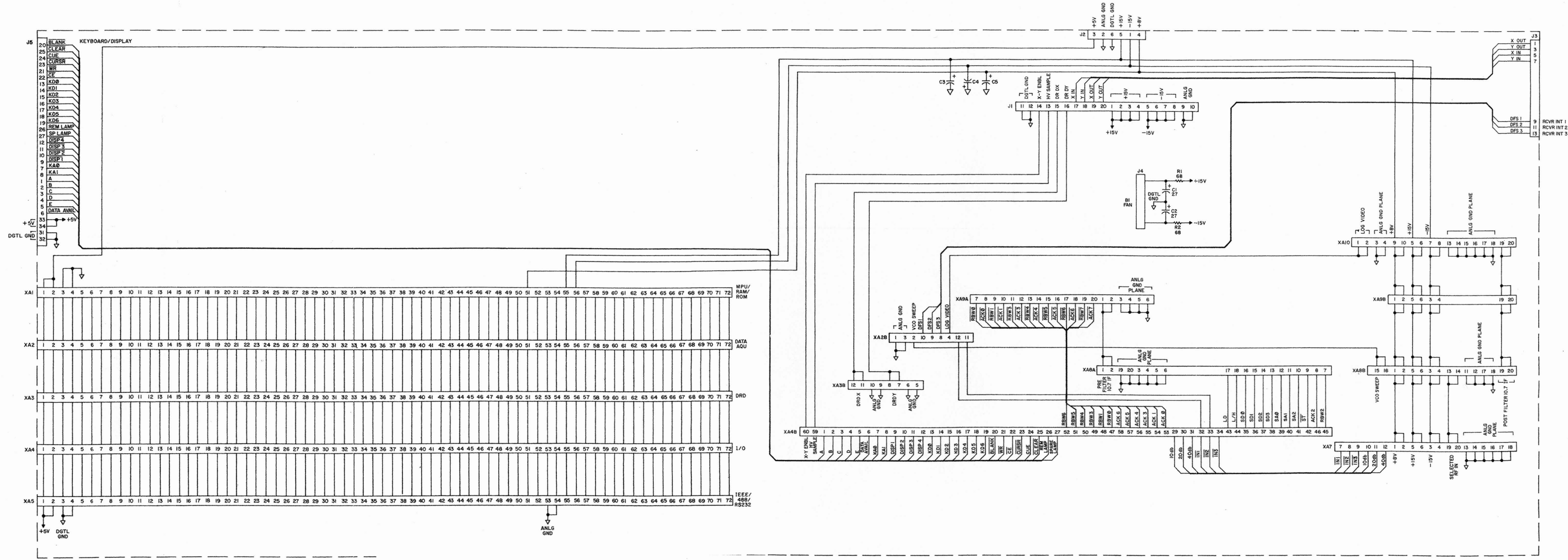

Figure 6-1. Type 796533-1, Motherboard Assembly (A1), Schematic Diagram 580534 (Sheet 1 of 2) (B) 6-1

Figure 6-1. Type 796533-1, Motherboard Assembly (A1), Schematic Diagram 580534 (Sheet 2 of 2) (B) 6-3

- NOTES:
 1. UNLESS OTHERWISE SPECIFIED:
 a) RESISTANCE IS IN OHMS, ±5%, 1/4W.
 b) CAPACITANCE IS IN µF.
 2. DIFFERENCE BETWEEN TYPE NUMBERS IS LISTED IN TABLE A.

TABLE A

TYPE	U1	U2	U4	U5	U6	JW1	JW2	JW3	JW4	JW5	JW6	JW7
796534-1	2764	N/U	N/U	6264LP		N/U	N/U	2-3	1-2	N/U	N/U	2-3
796534-2												

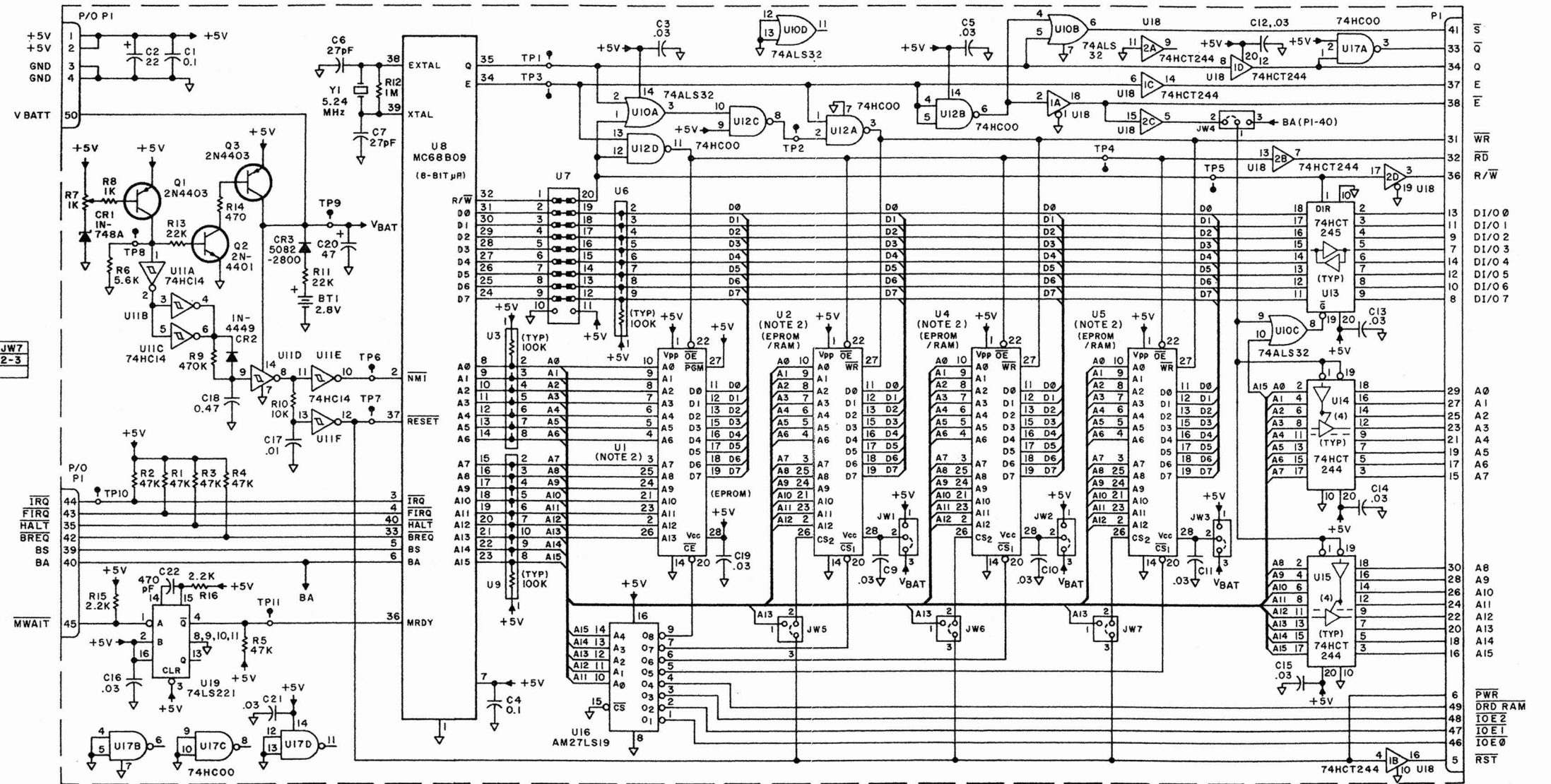

Figure 6-2. Type 796534-1, Microprocessor Assembly (A1A1), Schematic Diagram 580474 (A)

NOTES:
 1. UNLESS OTHERWISE SPECIFIED:
 a) CAPACITANCE IS IN μ F.
 b) RESISTANCE IS IN OHMS, 1/8W, 5%.
 2. PIN PI-58 IS SHOWN SEPARATED FOR FUNCTIONAL PURPOSES ONLY; ALL ARE TIED TOGETHER ON P.C. BOARD.

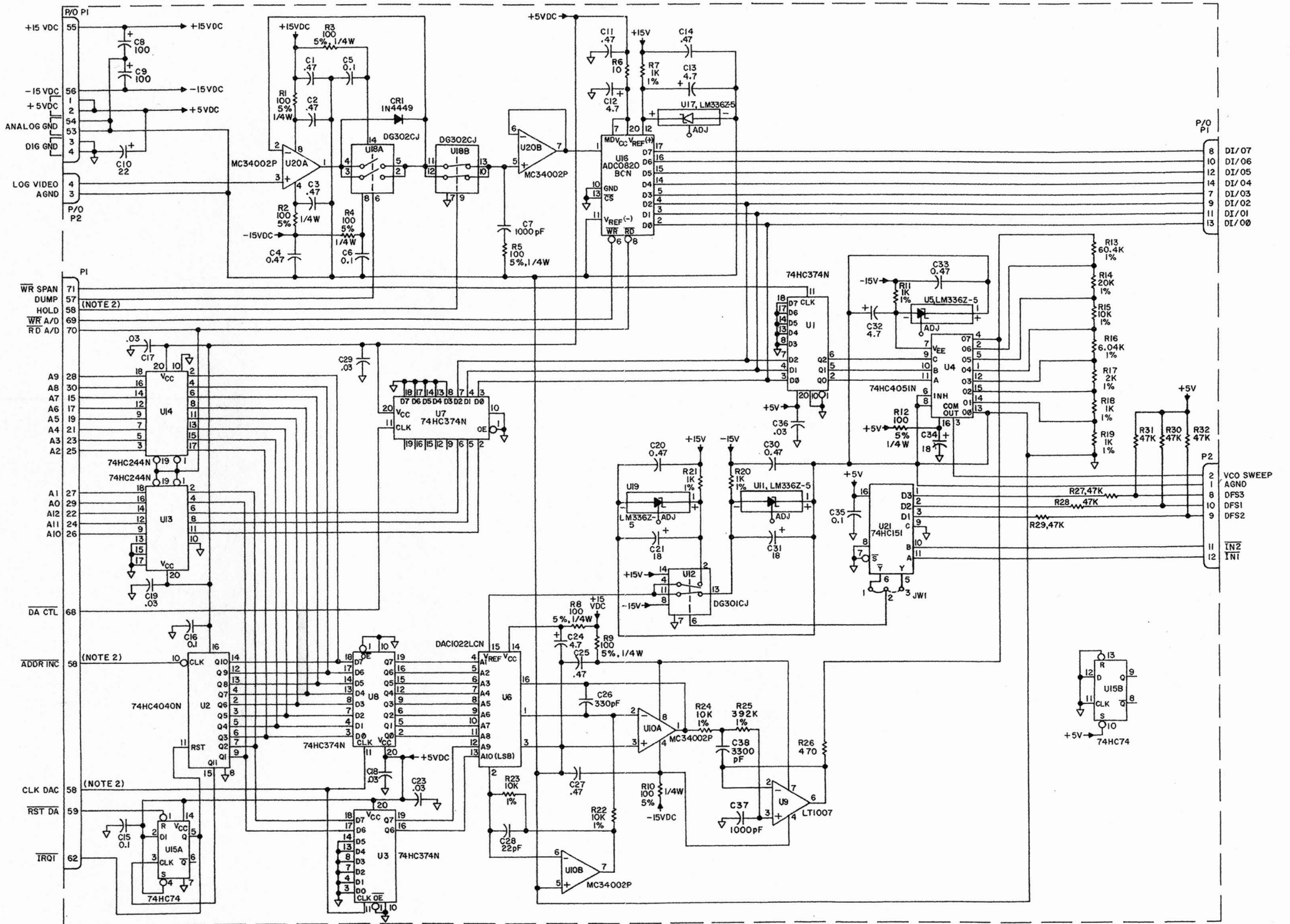

Figure 6-3. Type 796535-1, Data Acquisition Assembly (A1A2), Schematic Diagram 580508 (D)

NOTES:
 1. UNLESS OTHERWISE SPECIFIED:
 a) RESISTANCE IS IN OHMS, ±5%, 1/4W.
 b) CAPACITANCE IS IN μF.

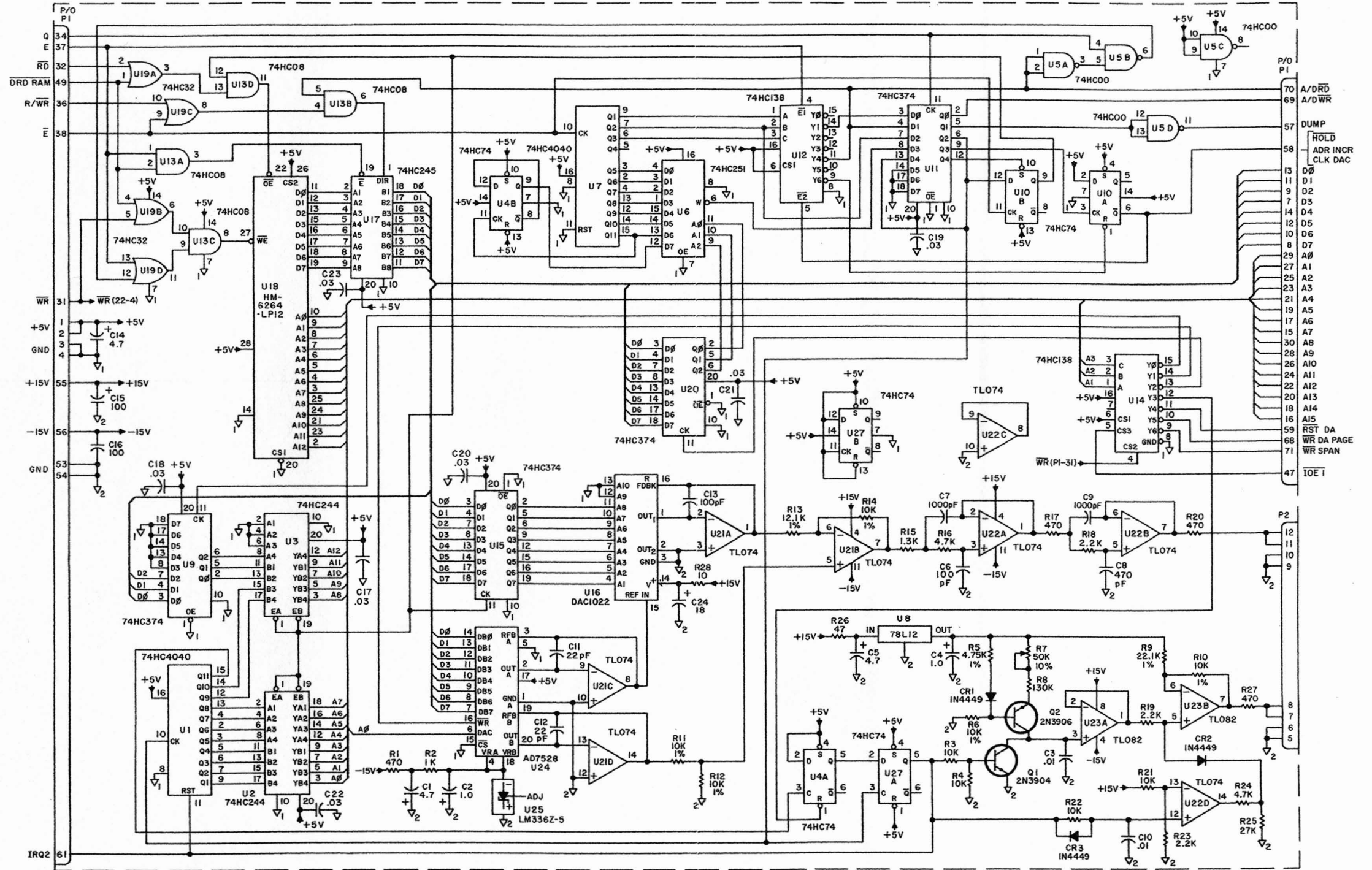

Figure 6-4. Type 796536-1, DRD/Timing Controller Assembly (A1A3), Schematic Diagram 580521 (C)

NOTES:
 1. UNLESS OTHERWISE SPECIFIED
 a) RESISTANCE IS IN OHMS, ± 1%, 1/10W.
 b) CAPACITANCE IS IN µF.

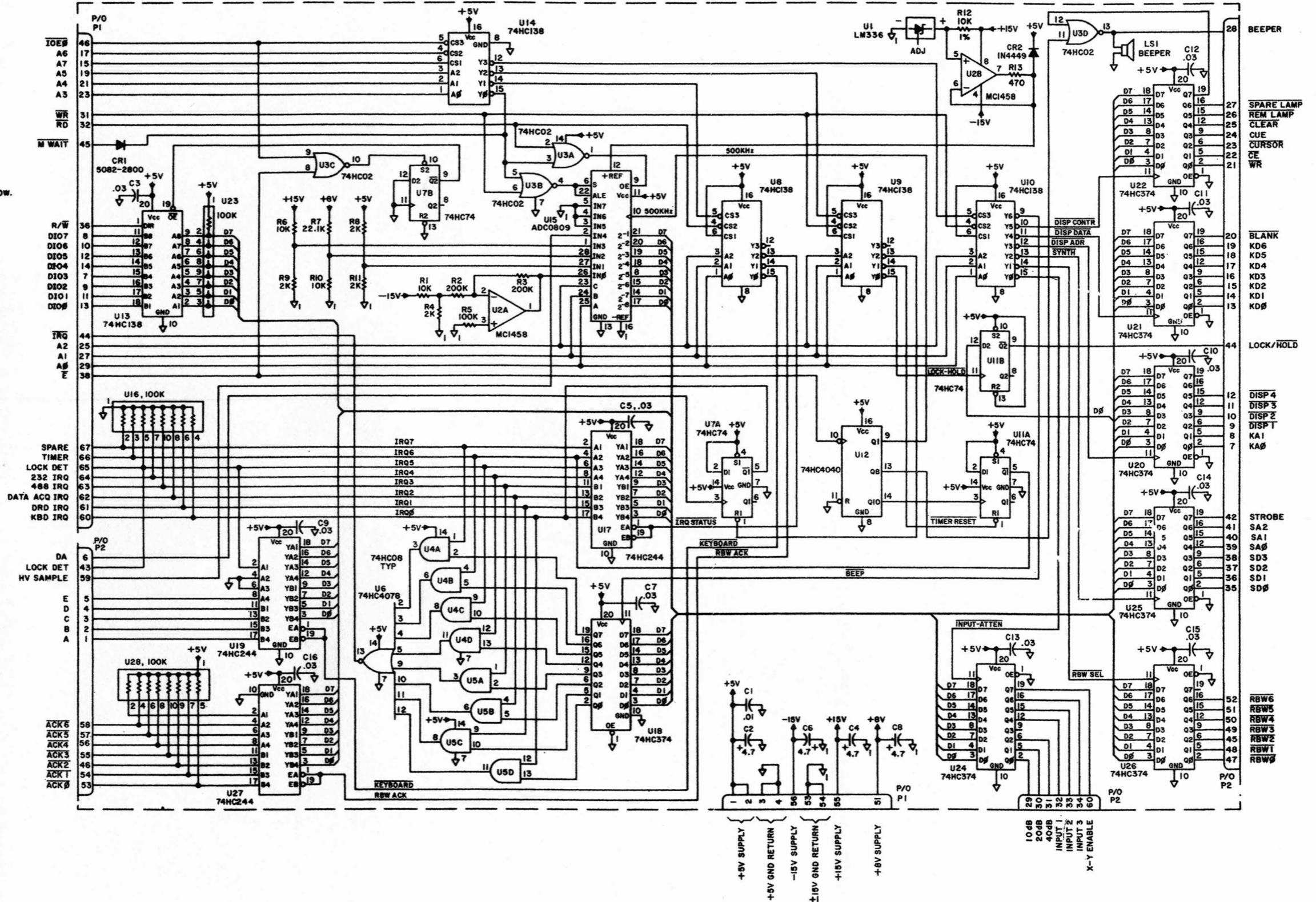

Figure 6-5. Type 796537-1, Input/Output Assembly (A1A4), Schematic Diagram 580551 (A)

- NOTES:
- 1. UNLESS OTHERWISE SPECIFIED:
 - a) RESISTANCE IS IN OHMS, ±5%, 1/4W.
 - b) CAPACITANCE IS IN μF.
 - 2 U7, U10-U15, C10, C11, Y1 NOT USED ON 796538-1.
 - 3 R1 OCCUPIES SAME HOLES AS C10 FOR 796538-1.

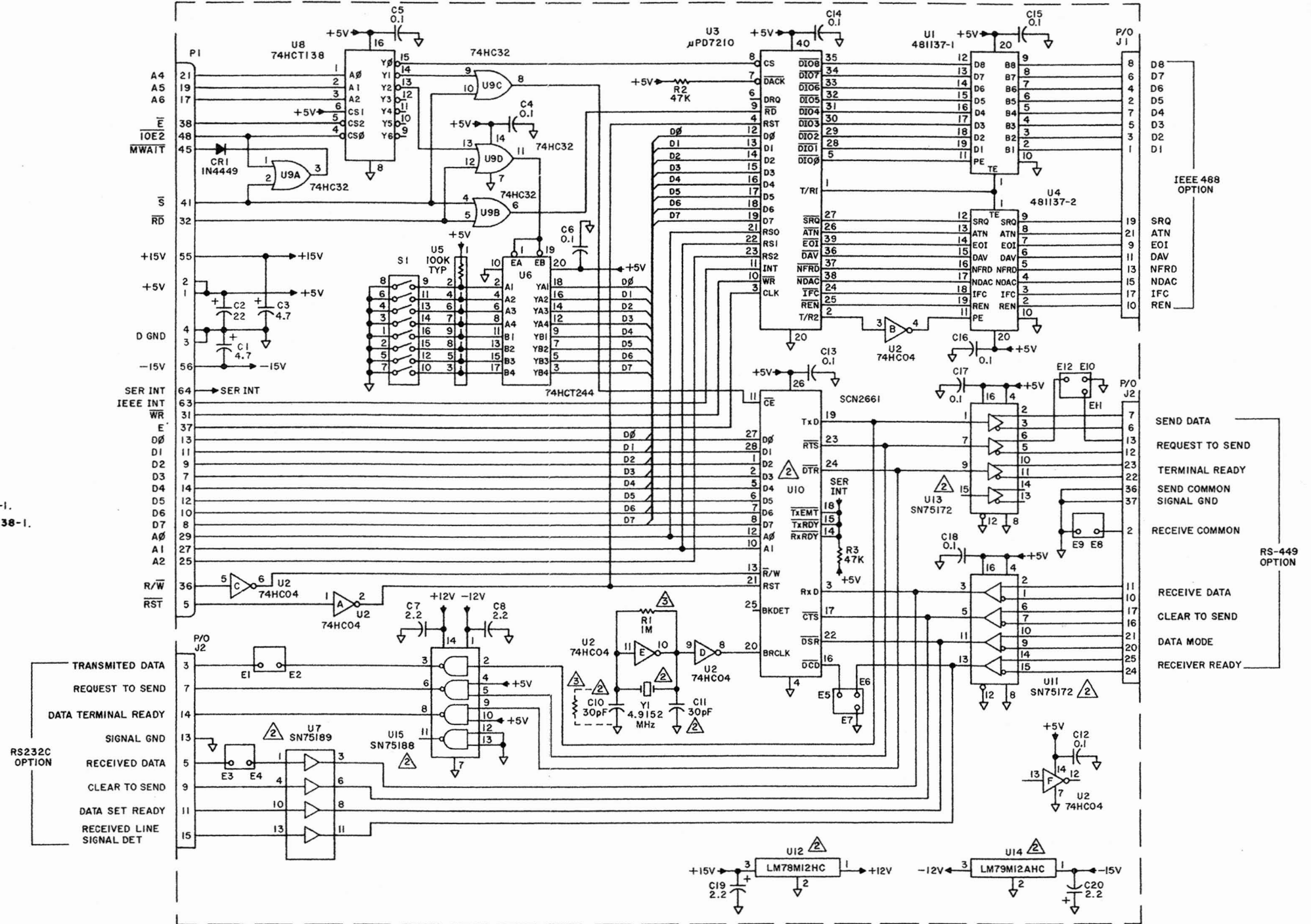

Figure 6-6. Type 796538-1, Remote Interface Board (A1A5), Schematic Diagram 580560 (B)

NOTES
 I. UNLESS OTHERWISE SPECIFIED:
 a) CAPACITANCE IS IN pF.

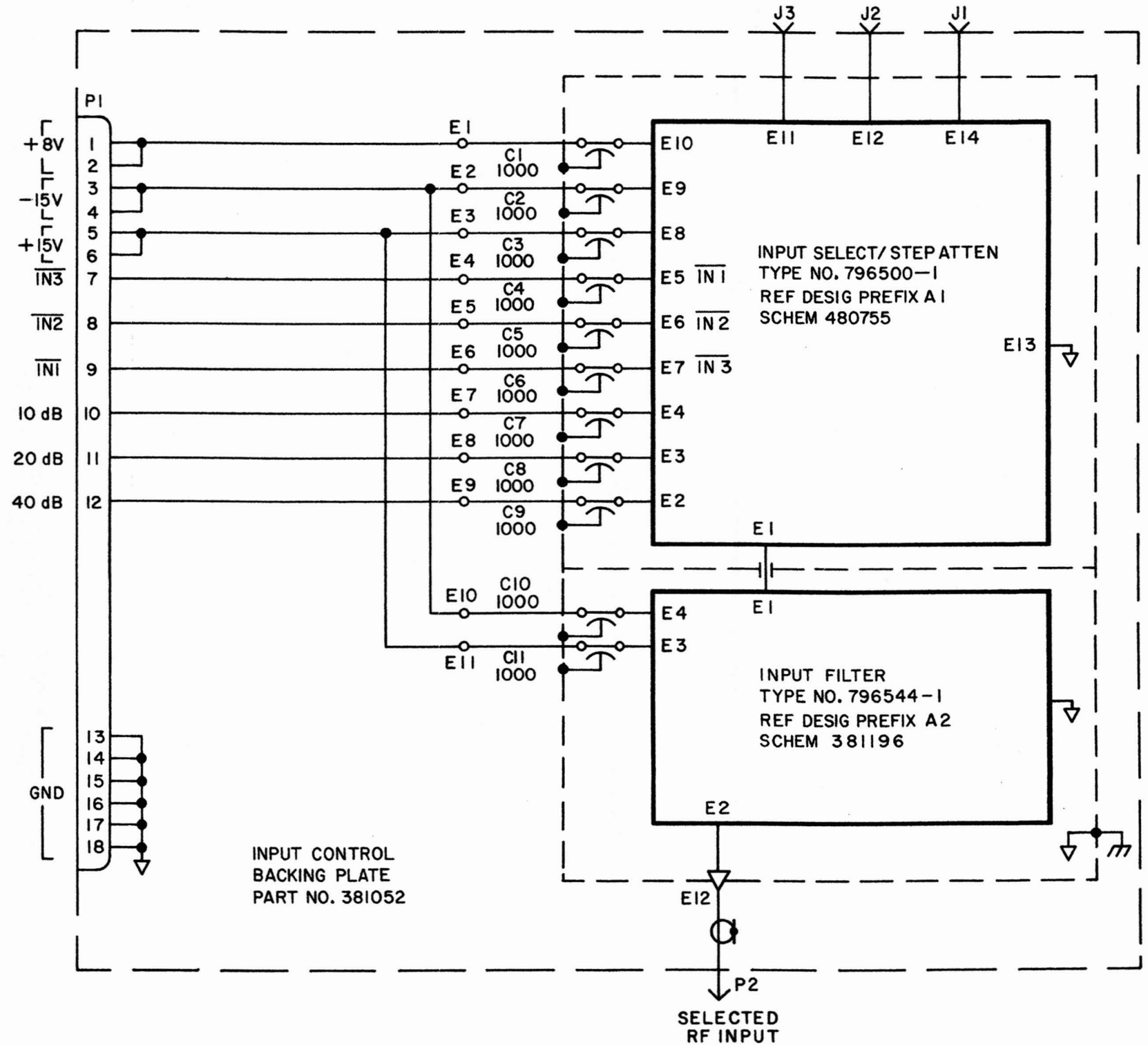

Figure 6-7. Type 796561-1, Input Control Assembly (A1A7), Schematic Diagram 381158 (A)

- NOTES: UNLESS OTHERWISE SPECIFIED:
 1. RESISTANCE IS IN OHMS, +5%, 1/4W.
 2. CAPACITANCE IS IN PF.
 3. INDUCTANCE IS IN UH.
 4. ALL DIODES ARE KS3542.

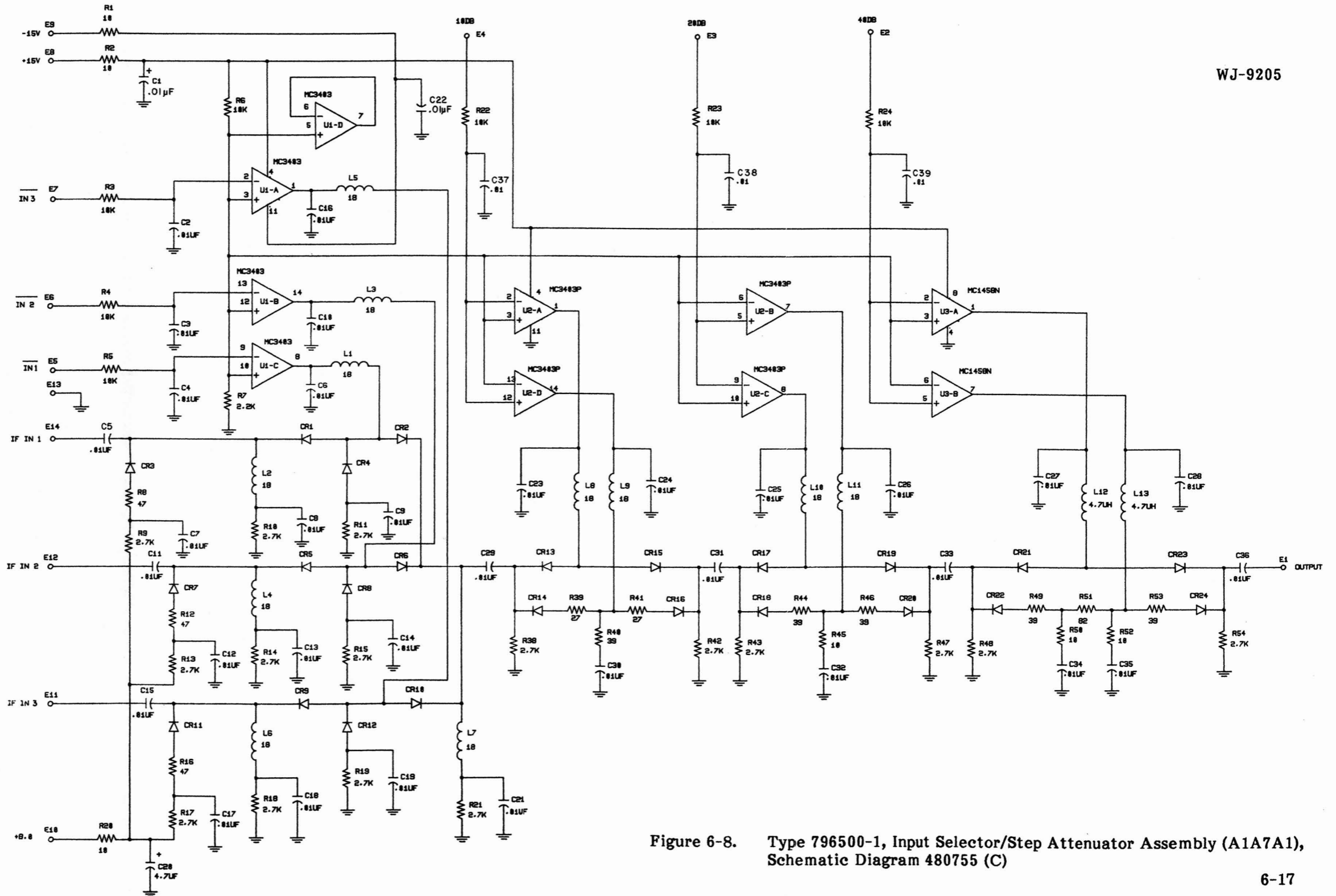

Figure 6-8. Type 796500-1, Input Selector/Step Attenuator Assembly (A1A7A1), Schematic Diagram 480755 (C)

NOTES:

I. UNLESS OTHERWISE SPECIFIED:

a) RESISTANCE IS IN OHMS $\pm 5\%$, 1/4 W

b) CAPACITANCE IS IN μF

c) INDUCTANCE IS IN μH

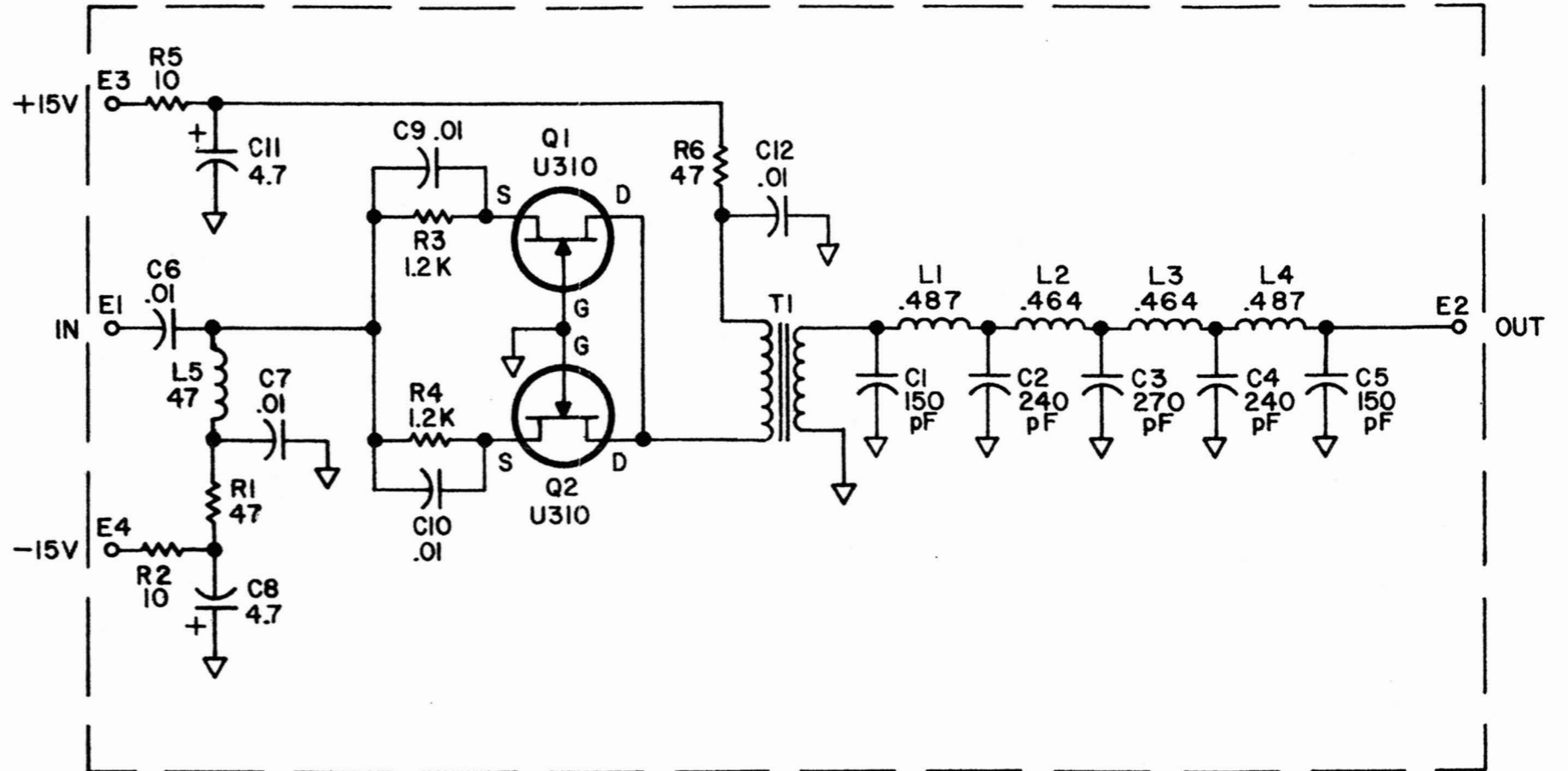

Figure 6-9. Type 796544-1, Input Filter Assembly (A1A7A2)
Schematic Diagram 381196 (A)

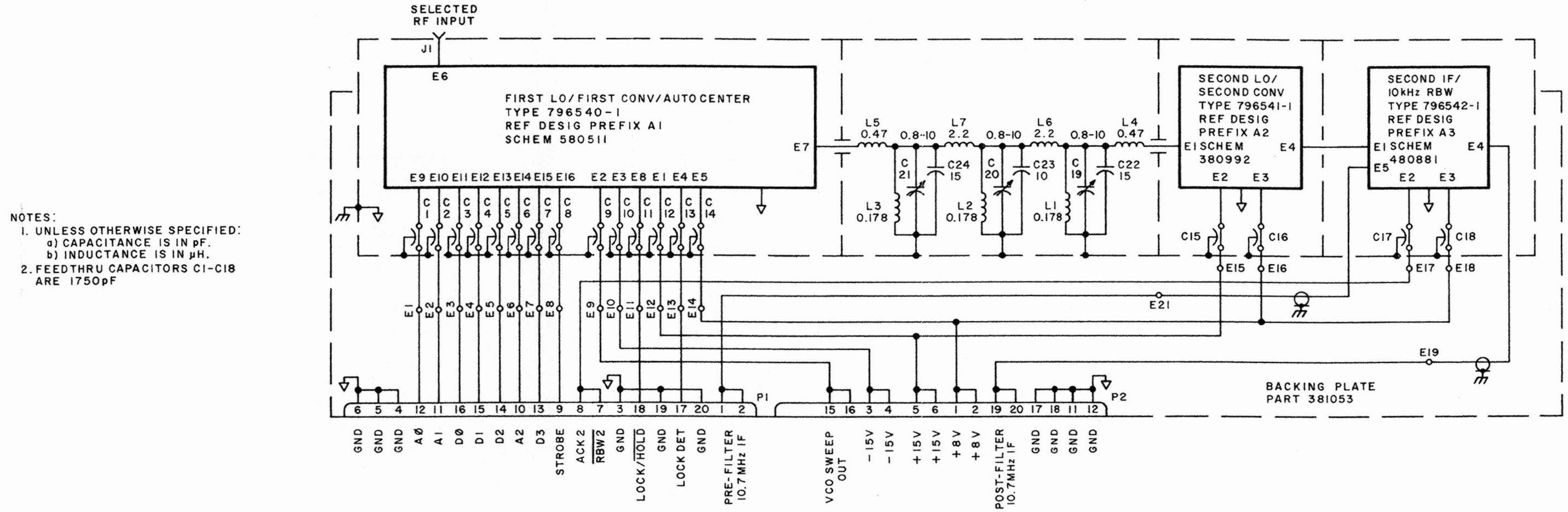

Figure 6-10. Type 796562-1, Frequency Converter/Sweep Assembly (A1A8), Schematic Diagram 480970 (A)

NOTES:
 1. UNLESS OTHERWISE SPECIFIED:
 a) RESISTANCE IS IN OHMS, ±5%, 1/4W; 1% ARE 1/10W.
 b) CAPACITANCE IS IN µF.
 c) INDUCTANCE IS IN µH.

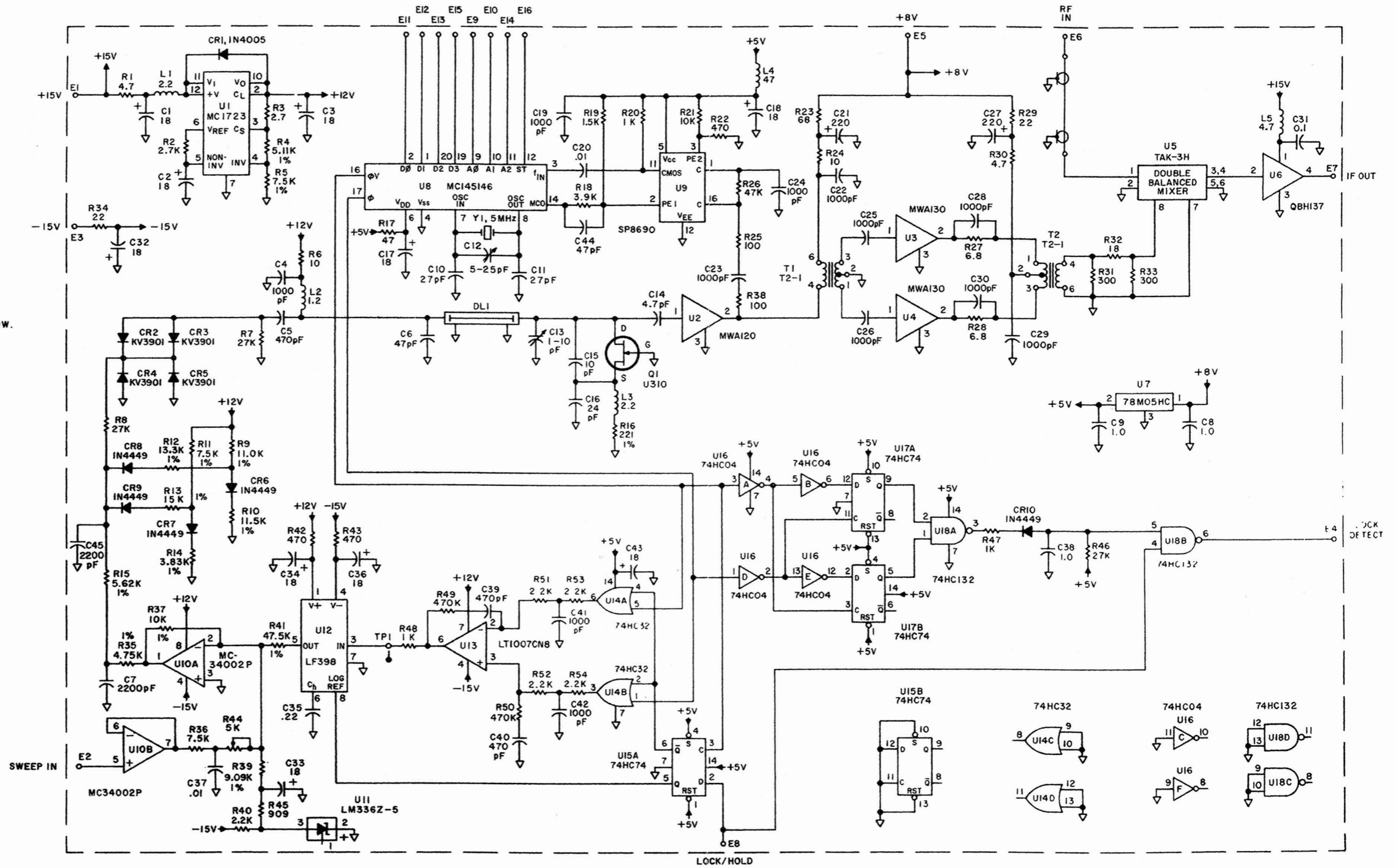
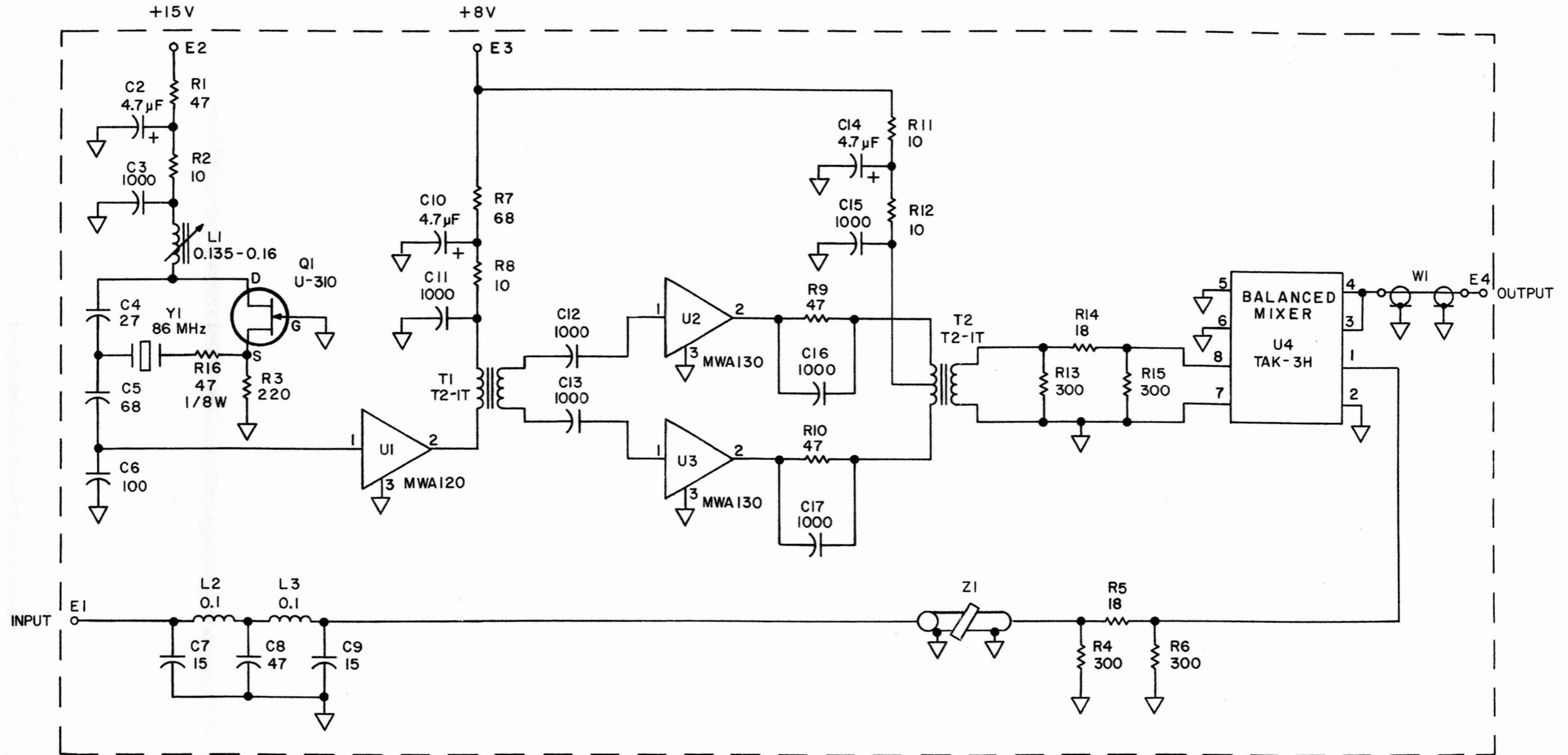

Figure 6-11. Type 796540-1, First LO/First Converter/Auto Centering Assembly (A1A8A1), Schematic Diagram 580511 (C)



NOTES:

- I. UNLESS OTHERWISE SPECIFIED:
 - a) RESISTANCE IS IN OHMS, $\pm 5\%$, 1/4 W.
 - b) CAPACITANCE IS IN pF.
 - c) INDUCTANCE IS IN μH .

Figure 6-12 Type 796541-1, Second LO/Second Converter Assembly (A1A8A2), Schematic Diagram 380992 (B)

NOTES:
 I. UNLESS OTHERWISE SPECIFIED:
 a) RESISTANCE IS IN OHMS, $\pm 5\%$, 1/4 W.
 b) CAPACITANCE IS IN μF .
 c) INDUCTANCE IS IN μH .

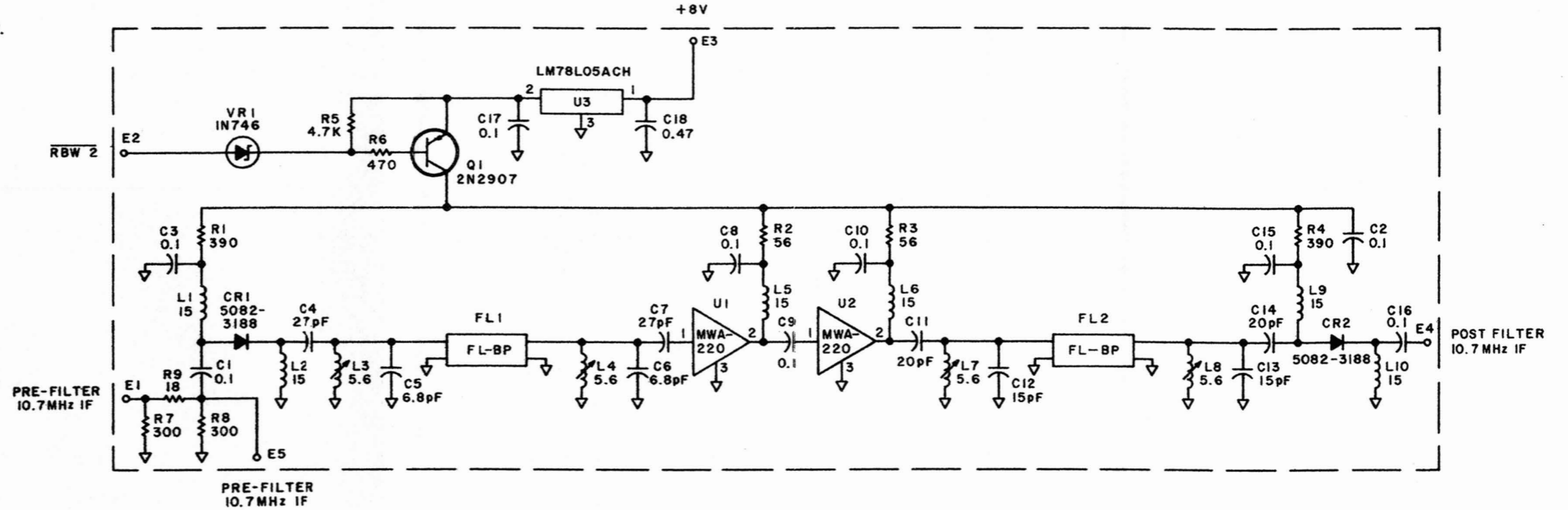
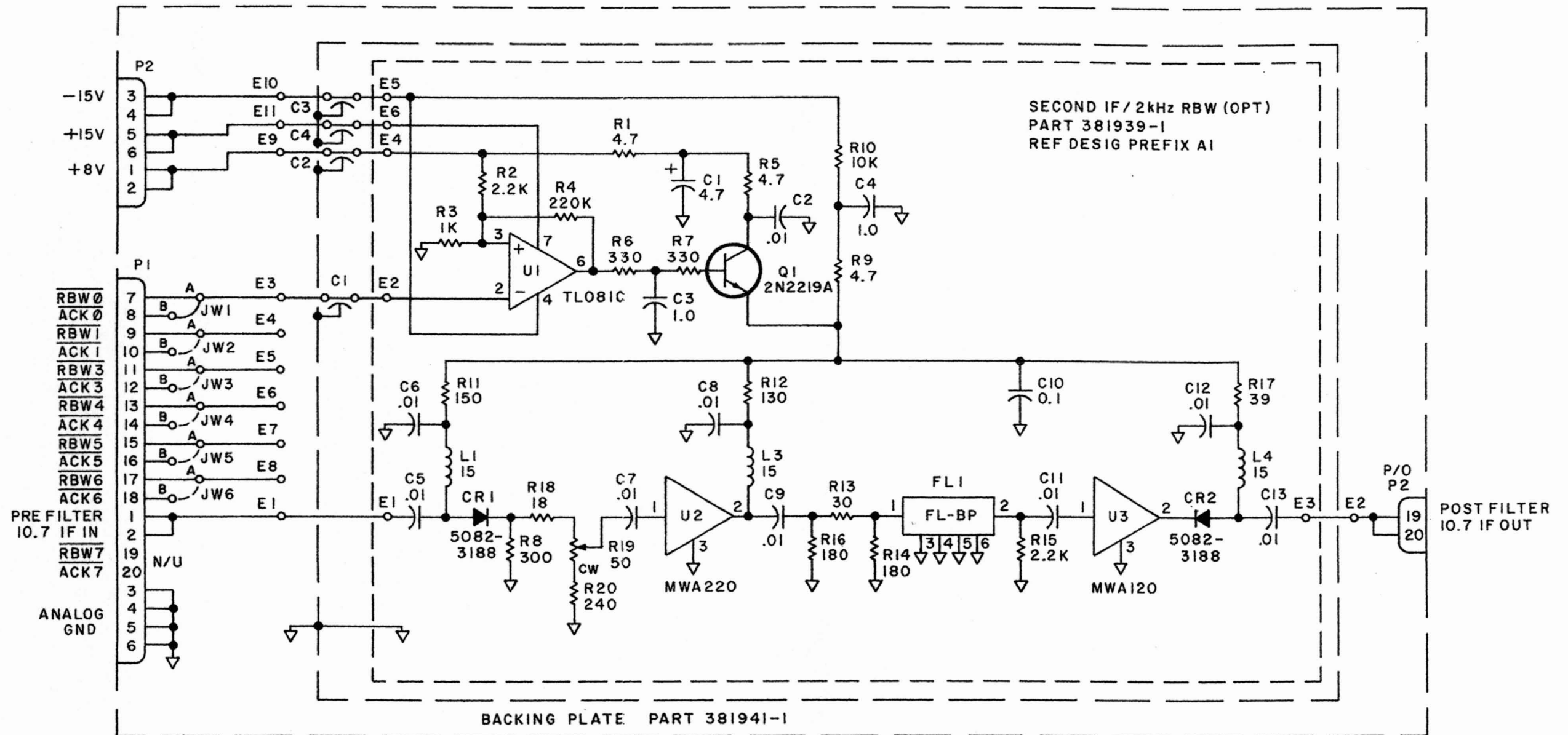

Figure 6-13. Type 796542-1, Second IF/RBW (10 kHz) Assembly (A1A8A3) Schematic Diagram 480881(A)



NOTES:

- I. UNLESS OTHERWISE SPECIFIED:
 - a) RESISTANCE IS IN OHMS, $\pm 5\%$, 1/4W.
 - b) CAPACITANCE IS IN μF .
 - c) INDUCTANCE IS IN μH .

Figure 6-14. Type 796790-1, Second IF/2kHz RBW Assembly (A1A9), Schematic Diagram 481466 (B)

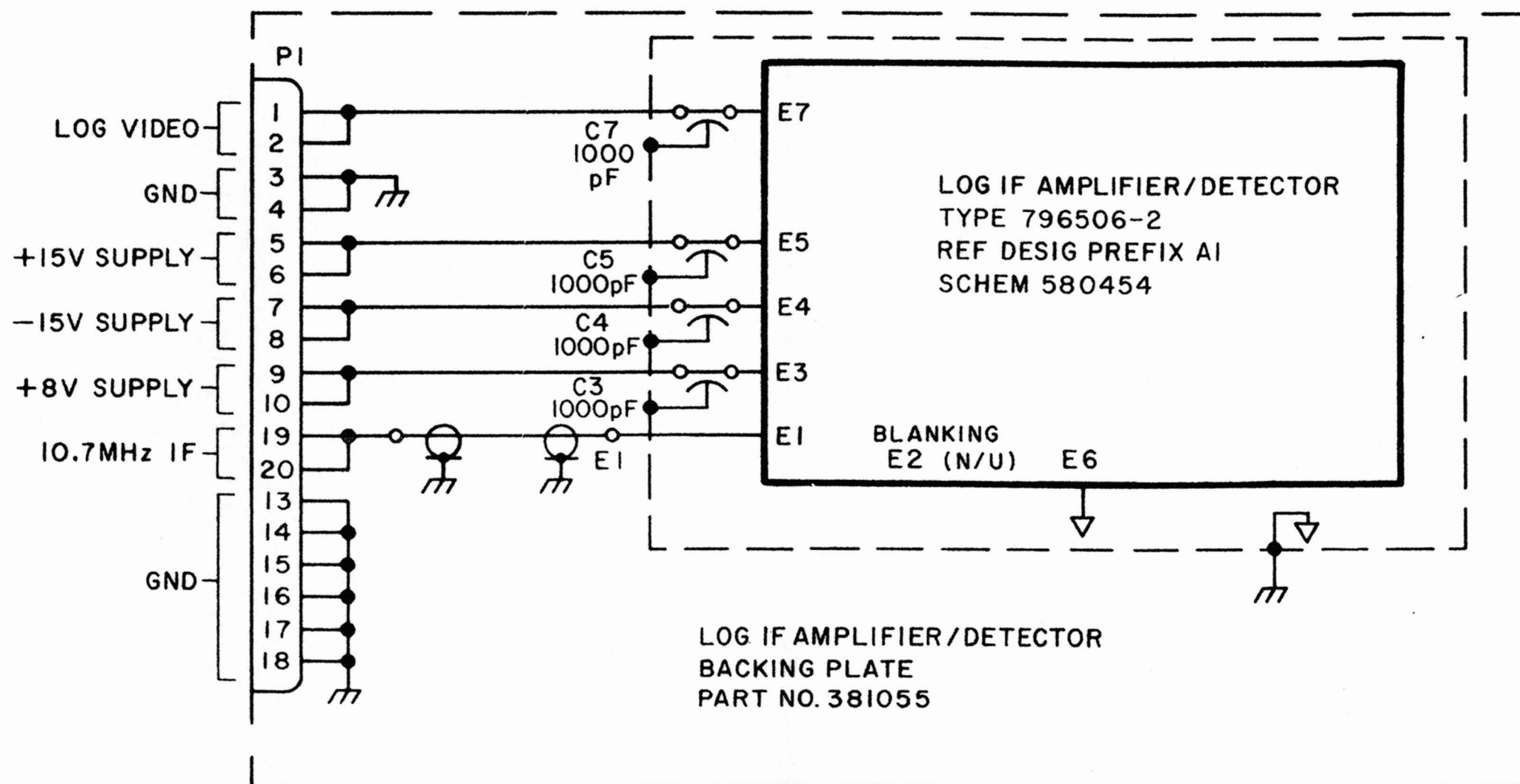
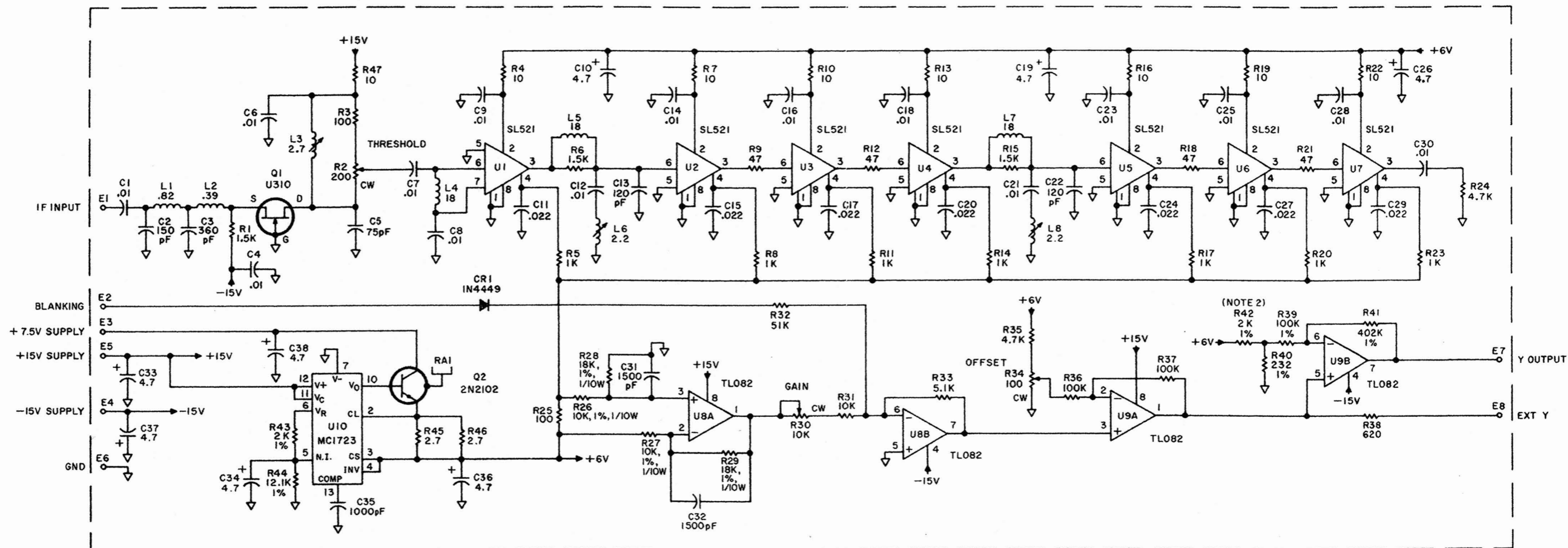

Figure 6-15. Type 796577-1, LOG IF Amplifier/Detector Assembly (A1A10), Schematic Diagram 381088 (A)



NOTES:

1. UNLESS OTHERWISE SPECIFIED:
 - a) RESISTANCE IS IN OHMS, $\pm 5\%$, 1/4W.
 - b) CAPACITANCE IS IN μF .
 - c) INDUCTANCE IS IN μH .
2. DWG IS SHOWN FOR 796506-1.
FOR 796506-2 OMIT R42.

Figure 6-16. Type 796506-2, LOG IF/Detector Assembly (A1A10A1), Schematic Diagram 580454 (C)

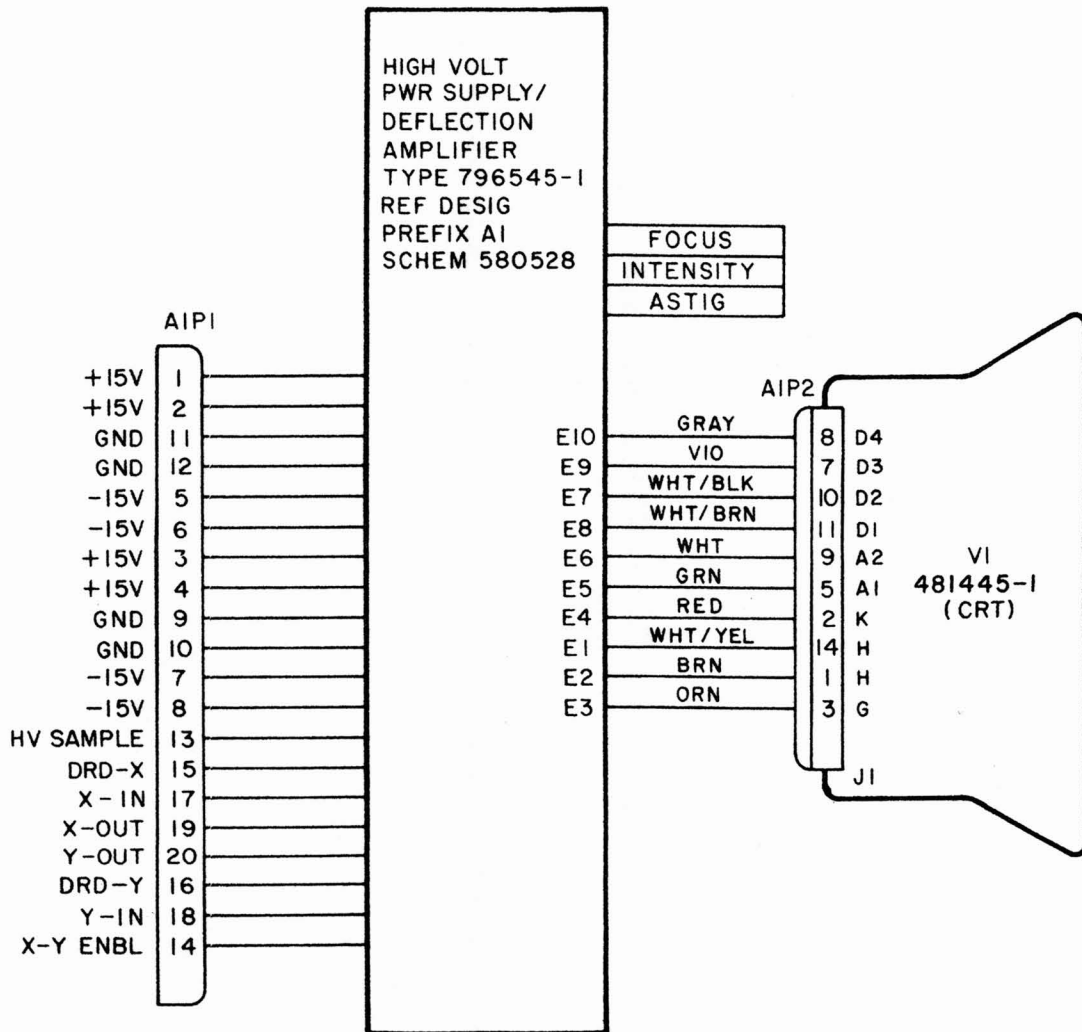
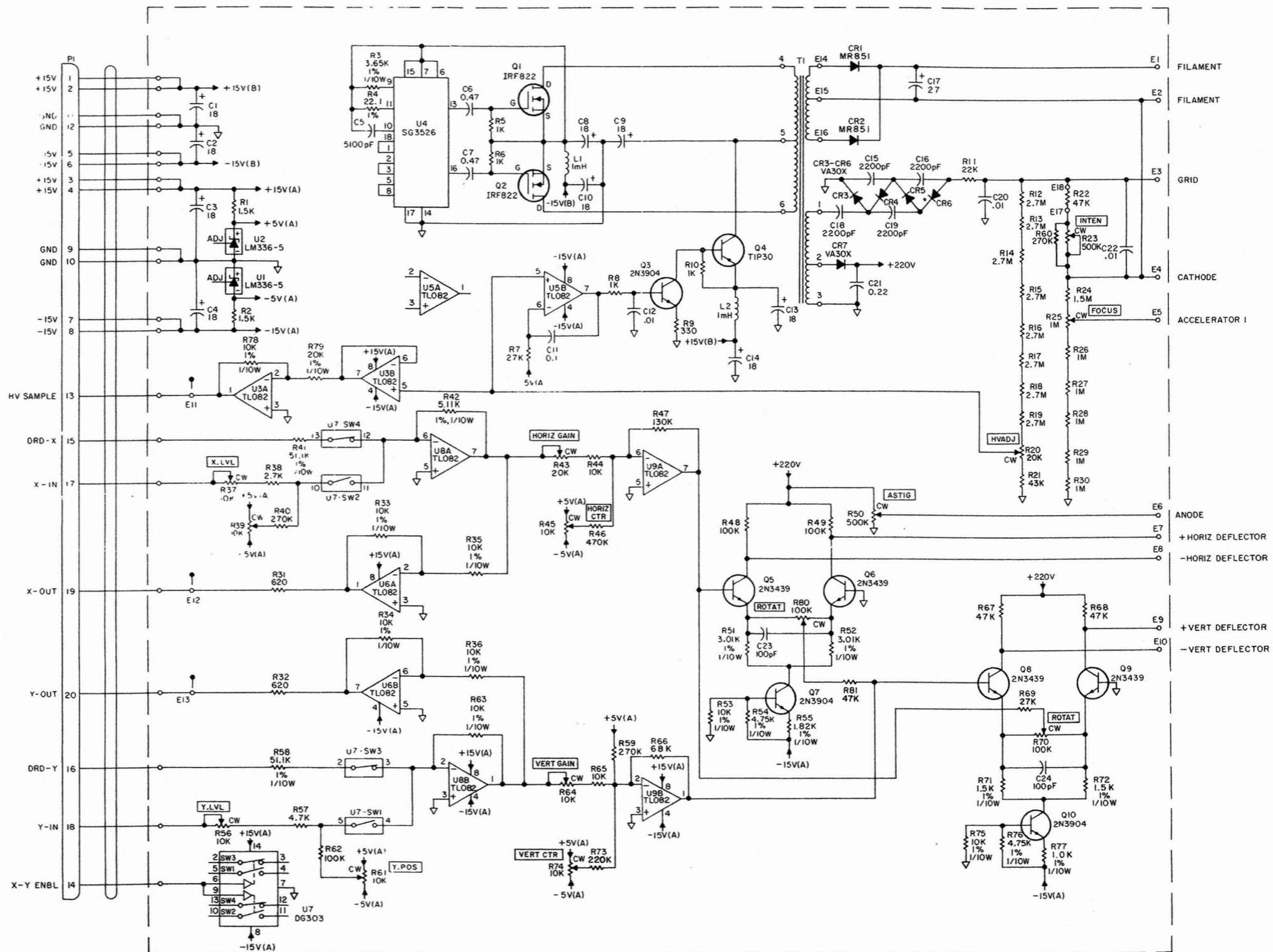
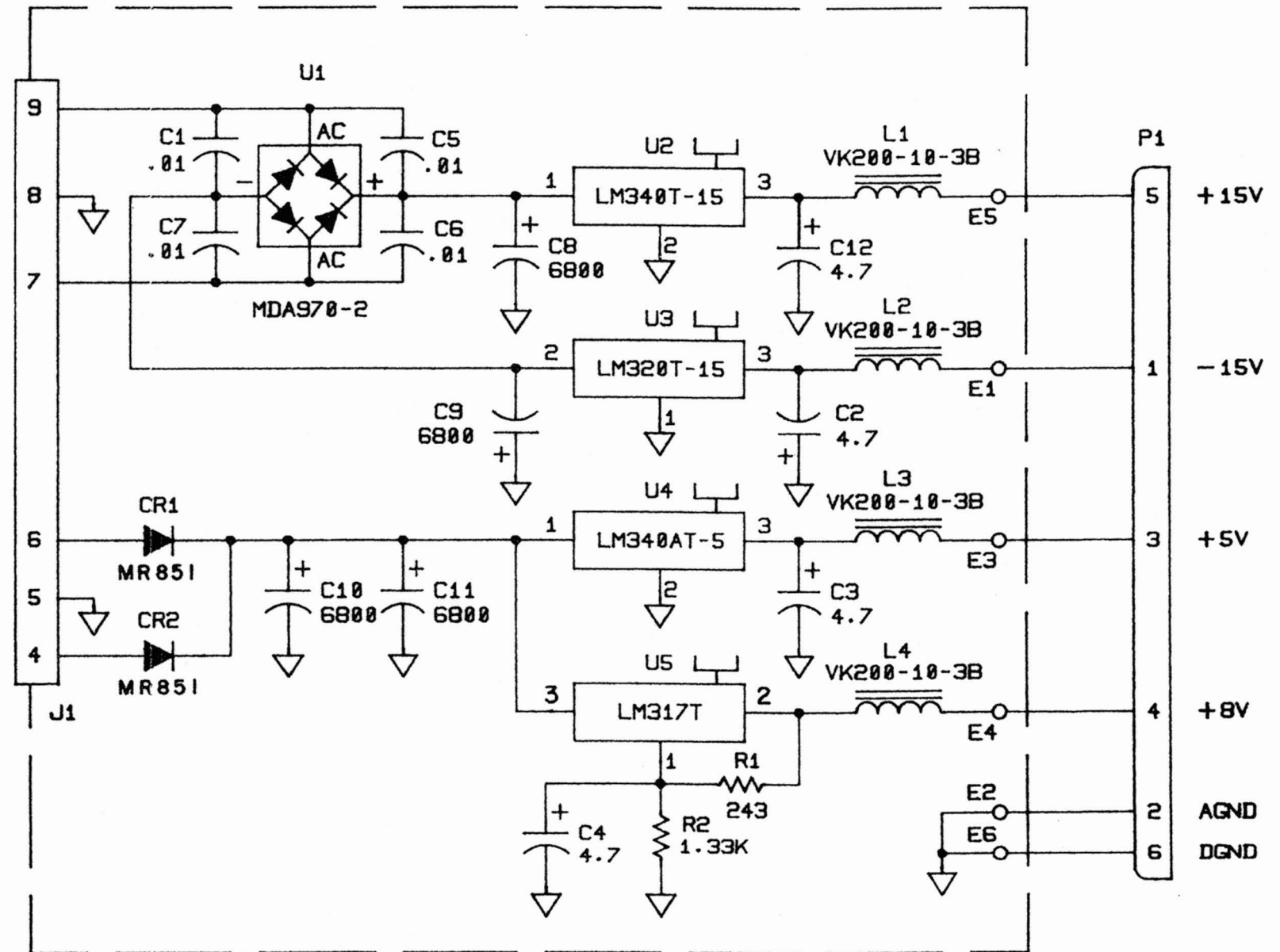

Figure 6-17. Type 796782-1, High Voltage Power Supply/Video (A2), Schematic Diagram 381891 (A)



NOTES:
 1. UNLESS OTHERWISE SPECIFIED:
 a) CAPACITANCE IS IN μ F.
 b) RESISTANCE IS IN OHMS, $\pm 5\%$, 1/4 W;
 VARIABLES ARE $\pm 10\%$, 1/2 W.

Figure 6-18. Type 796545-1, High Voltage Power Supply/Deflection Amplifier Assembly (A2A1), Schematic Diagram 580528 (A)



NOTES:

1. UNLESS OTHERWISE SPECIFIED:
 - A) RESISTANCE IS IN OHMS, $\pm 1\%$, 1/10W.
 - B) CAPACITANCE IS IN μF .

Figure 6-19. Type 796771-1, Power Supply (A3), Schematic Diagram 381840 (A)

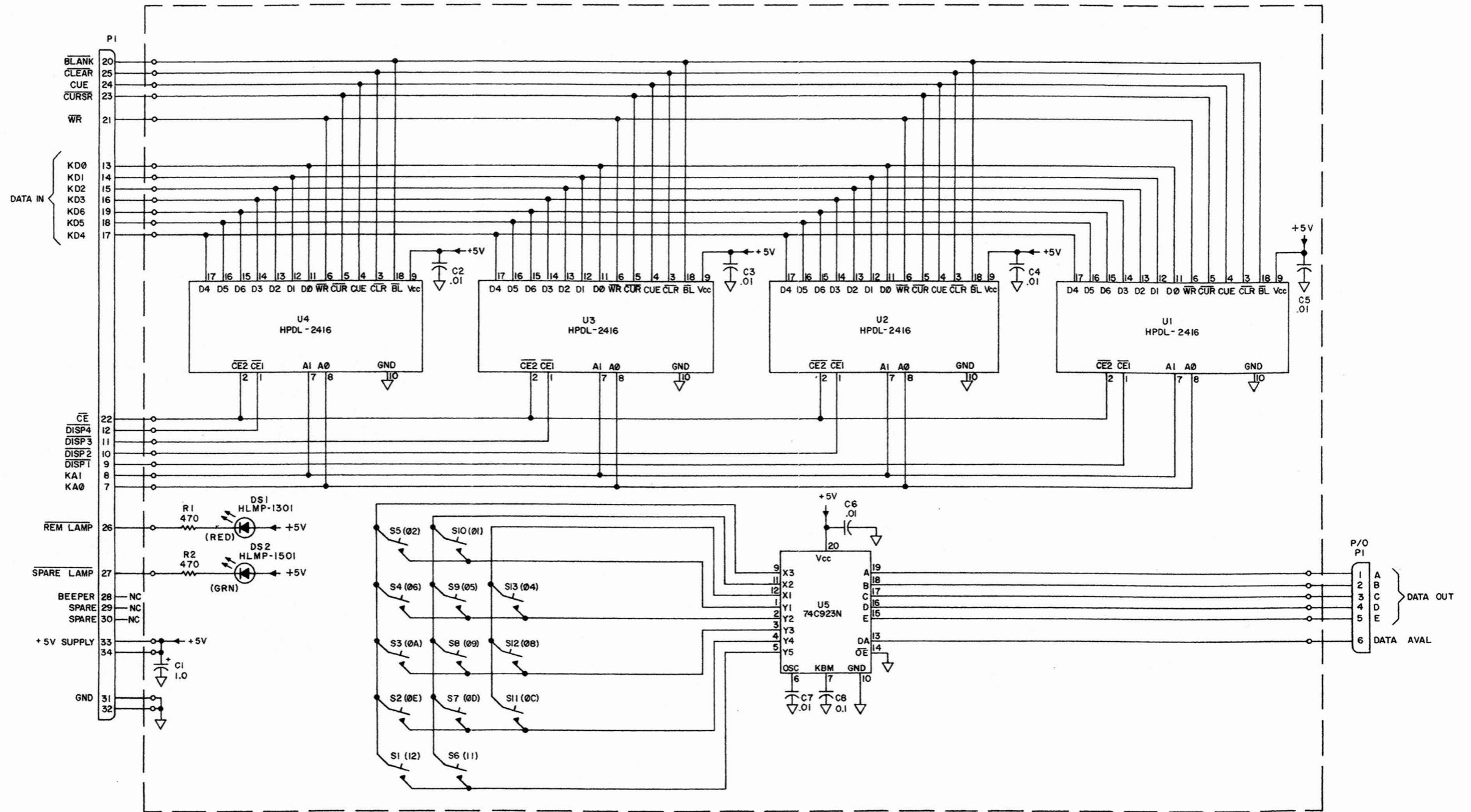

NOTES:
 1. UNLESS OTHERWISE SPECIFIED:
 a) RESISTANCE IS IN OHMS, ±5%, 1/4W.
 b) CAPACITANCE IS IN µF.

Figure 6-20. Type 796539-1, Keyboard Display (A4), Schematic Diagram 580502 (A)

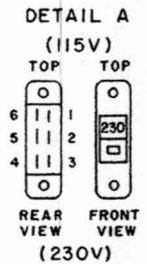
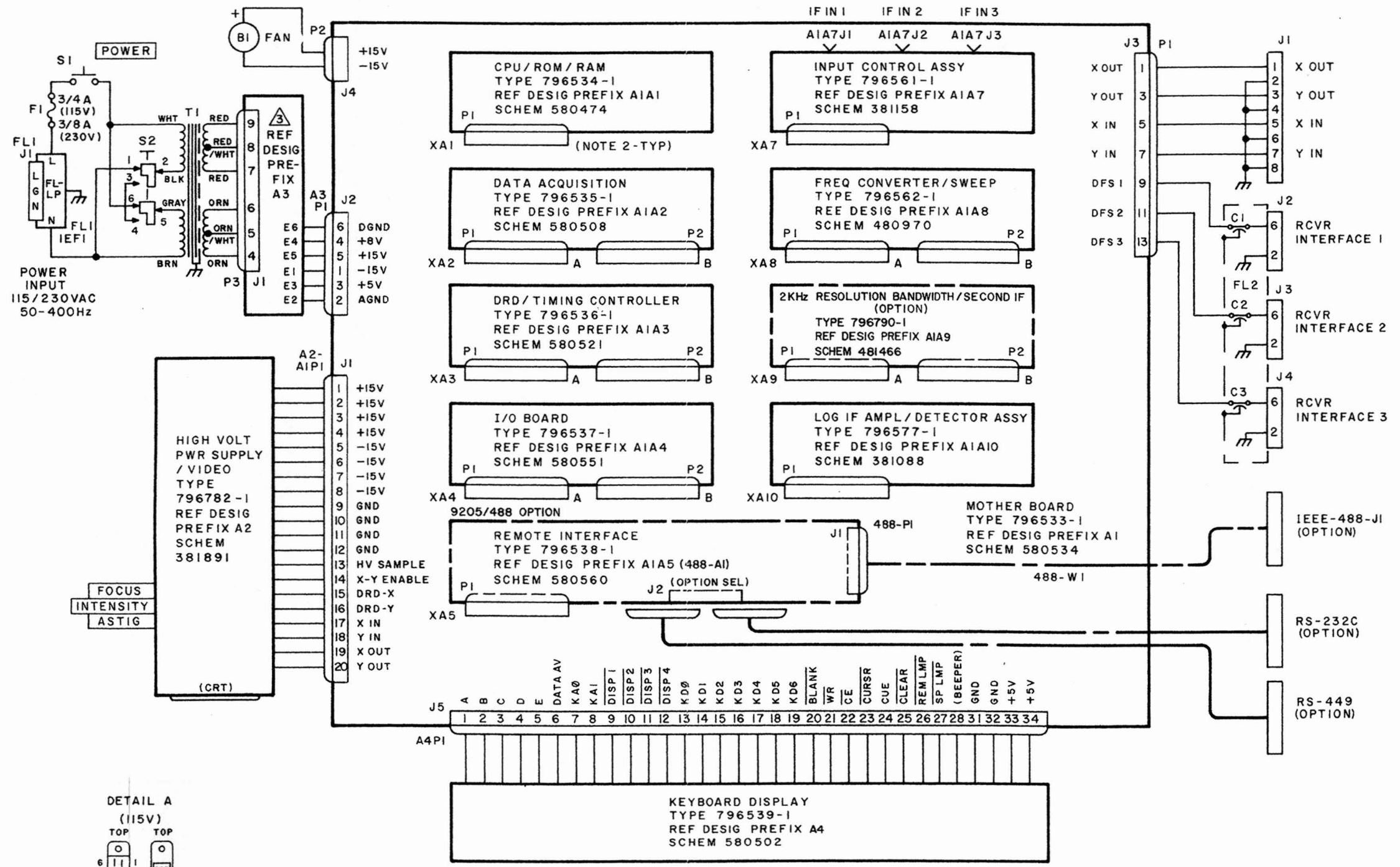

- NOTES:
1. DENOTES FRONT PANEL CONTROL.
 2. PINS/FUNCTIONS OF MODULES A1A1 THRU A1A10 ARE TO BE FOUND WITH EACH MODULE'S SCHEM.
 3. A3 MODULE: POWER SUPPLY TYPE 796771-1 SCHEM 381840
 4. PIN ARRANGEMENT IS SHOWN IN DETAIL A.

Figure 6-21. Type 9205 Signal Monitor, Main Chassis Schematic Diagram 480791 (A)

