

ARMY TM 11-5895-1303-24
NAVY EE162-NG-MMI-010/W110-RT1512G
AIR FORCE TO 31R2-4-562-2

UNIT, INTERMEDIATE DIRECT SUPPORT AND GENERAL SUPPORT MAINTENANCE MANUAL

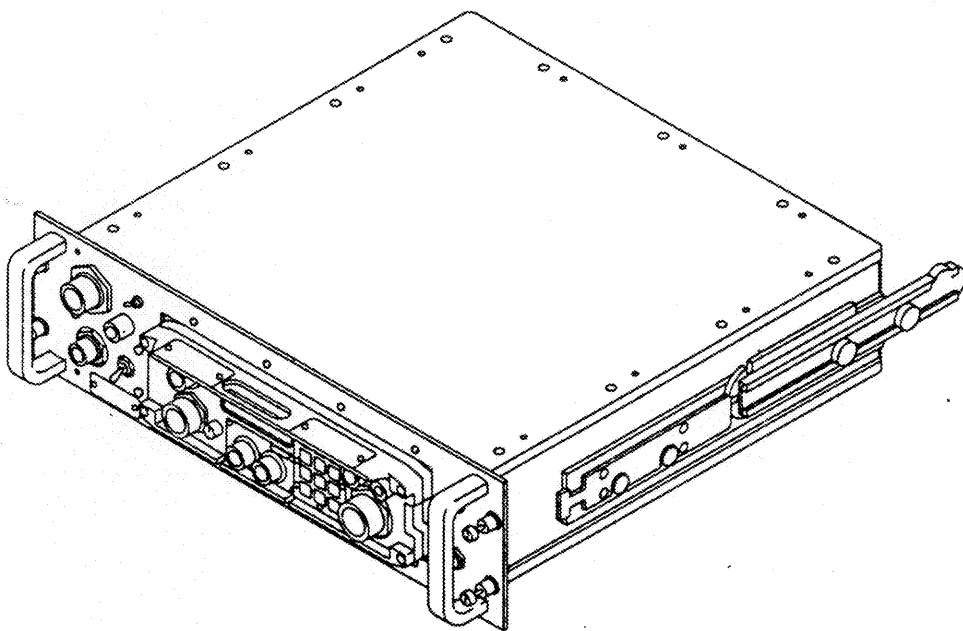

RECEIVER-TRANSMITTER RT-1512/G (NSN 5895-01-205-6148)

Distribution authorized to the Department of Defense and DOD contractors only for official use or for administration or operational purposes. This determination was made on 17 February 1989. Other requests for this document will be referred to Commander, US Army Communications-Electronics Command and Fort Monmouth, ATTN: AMSEL-LC-ME-P, Fort Monmouth, NJ 07703-5000.

DESTRUCTION NOTICE—Destroy by any method that will prevent disclosure of contents or reconstruction of the document.

HOW TO USE THIS MANUAL	III
EQUIPMENT DESCRIPTION AND DATA	1-3
UNIT MAINTENANCE	2-1
INTERMEDIATE DIRECT SUPPORT AND GENERAL SUPPORT MAINTENANCE	3-1
APPENDIXES	A-1
SUBJECT INDEX	I-1

DEPARTMENTS OF THE ARMY, THE NAVY, AND THE AIR FORCE

15 MAY 1989

TM 11-5895-1303-24
EE162-NG-MMI/W110-RT1512G
TO 31R2-4-562-2

Technical Manual
No. 11-5895-1303-24
Technical Manual
No. EE162-NG-MMI/W110-RT1512G
Technical Order
TO 31R2-4-562-2

DEPARTMENTS OF THE ARMY,
THE NAVY, AND THE AIR FORCE

Washington, DC, 15 May 1989

UNIT, INTERMEDIATE DIRECT SUPPORT AND
GENERAL SUPPORT MAINTENANCE MANUAL

RECEIVER-TRANSMITTER
RT-1512/G
(NSN 5895-01-205-6148)

REPORTING ERRORS AND RECOMMENDING IMPROVEMENTS

You can help improve this manual. If you find any mistakes or if you know of a way to improve the procedures, please let us know. Mail your letter, DA Form 2028 (Recommended Changes to Publications and Blank Forms) or DA Form 2028-2 located in back of this manual direct to: Commander, US Army Communications - Electronics Command and Fort Monmouth, ATTN: AMSEL-LC-ME-PS, Fort Monmouth, New Jersey 07703-5000.

For Air Force, submit AFTO Form 22 (Technical Order System Publication Improvement Report and Reply) in accordance with paragraph 6-5, Section VI, TO 00-5-1. Forward direct to prime SM-ALC/MMEDT McClellan AFB, CA 95652-5609.

For Navy, mail comments to the Commander, Space and Naval Warfare Systems Command, ATTN: SPAWAR PWM 152-4, Washington, DC 20363-5100.

In either case, a reply will be furnished direct to you.

	<u>Page</u>
HOW TO USE THIS MANUAL	iii
CHAPTER 1. INTRODUCTION	1-1
Section I. General Information	1-1
II. Equipment Description and Data	1-3
III. Principles Of Operation	1-11

	Page
CHAPTER 2. UNIT MAINTENANCE	2-1
Section I. Repair Parts, Special Tools; Test, Measurement, and Diagnostic Equipment (TMDE); Support Equipment	2-1
II. Service Upon Receipt	2-2
III. Preventive Maintenance Checks and Services (PMCS) ..	2-4
IV. Unit Troubleshooting	2-6
V. Unit Maintenance	2-8
VI. Preparation for Storage or Shipment	2-18
CHAPTER 3. INTERMEDIATE DIRECT SUPPORT AND GENERAL SUPPORT MAINTENANCE	3-1
Section I. Repair Parts, Special Tools; Test, Measurement, and Diagnostic Equipment (TMDE); and Support Equipment	3-1
II. Intermediate General Support Troubleshooting	3-2
III. Intermediate General Support Maintenance	3-79
APPENDIX A. REFERENCES	A-1
APPENDIX B. MAINTENANCE ALLOCATION CHART	B-1
APPENDIX C. EXPENDABLE/DURABLE SUPPLIES AND MATERIALS LIST	C-1
GLOSSARY	GLOSSARY-1
Section I. Abbreviations and Acronyms	GLOSSARY-1
Section II. Definitions of Unusual Terms ...	GLOSSARY-5
SUBJECT INDEX	INDEX-1

CAUTION



This equipment contains certain static-sensitive solid state devices which are subject to damage from electrostatic discharge. Effective control of electrostatic discharge is maintained only through continuous strict observance of the following maintenance procedures:

- **Any maintenance requiring disassembly of the equipment must be performed at an approved work station. The work station must include a grounded surface and grounded wrist strap in accordance with DOD-HDBK-263.**
- **All maintenance personnel must have completed training in the handling of static-sensitive devices before working on this equipment. Maintenance personnel must wear the grounded wrist strap and be at an approved work station when performing maintenance.**
- **The static-sensitive subassemblies or circuit cards must be stored in approved electrostatic free material when not installed in the equipment.**

**5****SAFETY STEPS TO FOLLOW IF SOMEONE IS THE VICTIM OF ELECTRICAL SHOCK****1****DO NOT TRY TO PULL OR GRAB THE INDIVIDUAL****2****IF POSSIBLE, TURN OFF THE ELECTRICAL POWER****3****IF YOU CANNOT TURN OFF THE ELECTRICAL POWER, PULL, PUSH, OR LIFT THE PERSON TO SAFETY USING A DRY WOODEN POLE OR A DRY ROPE OR SOME OTHER INSULATING MATERIAL****4****SEND FOR HELP AS SOON AS POSSIBLE****5****AFTER THE INJURED PERSON IS FREE OF CONTACT WITH THE SOURCE OF ELECTRICAL SHOCK, MOVE THE PERSON A SHORT DISTANCE AWAY AND IMMEDIATELY START ARTIFICIAL RESUSCITATION****NOTE: DON'T WAIT UNTIL AN ACCIDENT HAPPENS! READ ABOUT ARTIFICIAL RESPIRATION IN FM21-11. AIR FORCE PERSONNEL REFER TO AFOSH 127-50 AND AFOSH 127-66, CHAPTER 10.**

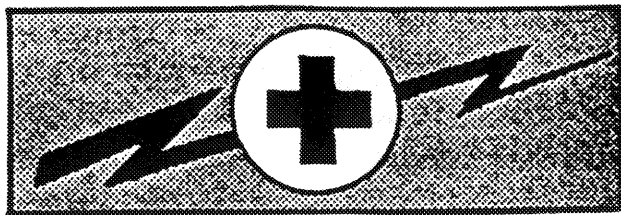
WARNING**HIGH VOLTAGE**

is used in the operation of this equipment

DEATH ON CONTACT

may result if personnel fail to observe safety precautions

Never work on electronic equipment unless there is another person nearby who is familiar with the operation and hazards of the equipment and who is competent in administering first aid. When the technicians are aided by operators, they must be warned about dangerous areas.

Whenever possible, the power supply to the equipment must be shut off before beginning work on the equipment. Take particular care to ground every capacitor likely to hold a dangerous potential. When working inside the equipment, after the power has been turned off, always ground every part before touching it.

Be careful not to contact high-voltage connections or 115 volt ac input connections when installing or operating this equipment.

Whenever the nature of the operation permits, keep one hand away from the equipment to reduce the hazard of current flowing through the body.

Warning: Do not be misled by the term "low voltage." Potentials as low as 50 volts may cause death under adverse conditions.

For Artificial Respiration, refer to FM 21-11.

WARNING

The Receiver-Transmitter RT-1512/G weighs more than 35 lbs.
Two persons are required to remove or install this unit.

1-6. PREPARATION FOR STORAGE OR SHIPMENT

a. Army. Before placing equipment into administrative storage, insure that equipment is operational. If operational put into storage using appropriate corrosion control techniques. When removing from storage, again perform operational tests and Unit PMCS, (if available) to determine mission capability.

b. Navy. Refer to NAVSUP PUB 503.

c. Air Force. Refer to AFM 66-267 (storage) and AFR 67-31 (shipment).

1-7. OFFICIAL NOMENCLATURE, NAMES, AND DESIGNATIONS

COMMON NAME	OFFICIAL NOMENCLATURE
RT Chassis assembly Electronic counter- countermeasures module (ECCM)	Receiver-Transmitter, RT-1512/G Chassis Assembly, A1, P/N A3024604 Controller, Receiver-Transmitter C-11670/G, A2, P/N A3023813
Frequency synthesizer	Frequency Synthesizer, A3, P/N A3024340
Reference oscillator	Reference Frequency Oscillator, A4, P/N A3024618
Audio sideband exciter	Audio Sideband Exciter Assembly, A5, P/N A3024629
RF amplifier exciter	RF Amplifier Exciter Assembly, A6, P/N A3024634
RF switch	RF Switch Assembly, A7, P/N A3024649
RF receiver	RF Receiver Assembly, A8, P/N A3024644
IF receiver	IF Receiver Assembly, A9, P/N A3024639
Audio receiver	Audio Receiver Assembly, A10, P/N A3024654
Power supply (PS) Motherboard (A1A1)	Power Supply Assembly, PS1, P/N A3024060 Module Interconnect CCA, A1A1, P/N A3024659
Chassis matrix board A1W3	Printed Cable Assembly, Flexible Interconnect, A1W3, P/N A3024609

Section II. EQUIPMENT DESCRIPTION AND DATA

1-8. EQUIPMENT CHARACTERISTICS, CAPABILITIES, AND FEATURES

a. Characteristics:

- The RT is a SSB receiving and transmitting radio operating in the 2.0000 to 29.9999 MHz frequency band.
- The RT is capable of upper or lower SSB operation and remote control operation.

1-8. EQUIPMENT CHARACTERISTICS, CAPABILITIES, AND FEATURES (Cont.)

a. Characteristics (Cont.):

- The RT has built-in test (BIT) circuits to isolate faults to the module level and provide BIT status to the system.

b. Capabilities and Features:

- The RT has a double conversion receiver with up-conversion to a narrow intermediate frequency (IF) to minimize spurious susceptibility.
- The transmitter (exciter) portion of the RT down-converts from a high IF to the desired frequency in the 2 to 30 MHz band to minimize transmitter spurious outputs.
- The RT provides for control of the RF output power level of the 400 watt power amplifier to within ± 1 dB through feedback to the RT.
- The RT provides output digital tuning information for antenna tuning and condition selection.
- The RT amplifies the modulated RF signal to a nominal 100 mW peak envelope power (PEP), when transmitting.
- The frequency synthesizer uses a multiple loop design which achieves settling times of 400 microseconds or less, with low phase noise and reduced broadband noise.

1-9. LOCATION AND DESCRIPTION OF MAJOR COMPONENTS

The RT is a HF SSB radio. It is rack mounted for use in several communications systems.

- ① ECCM Module A2. Is mounted, as an integral part of the RT, in the front of the RT. Provides ECCM operational control and display for the RT.
- ② Chassis Assembly A1. Provides for mounting and protection for the internal components of the RT.

1-9. LOCATION AND DESCRIPTION OF MAJOR COMPONENTS (Cont.)

NOTE: FOR DESCRIPTION AND PURPOSE OF FRONT PANEL CONTROLS, REFER TO OPERATOR TM FOR THE SYSTEM.

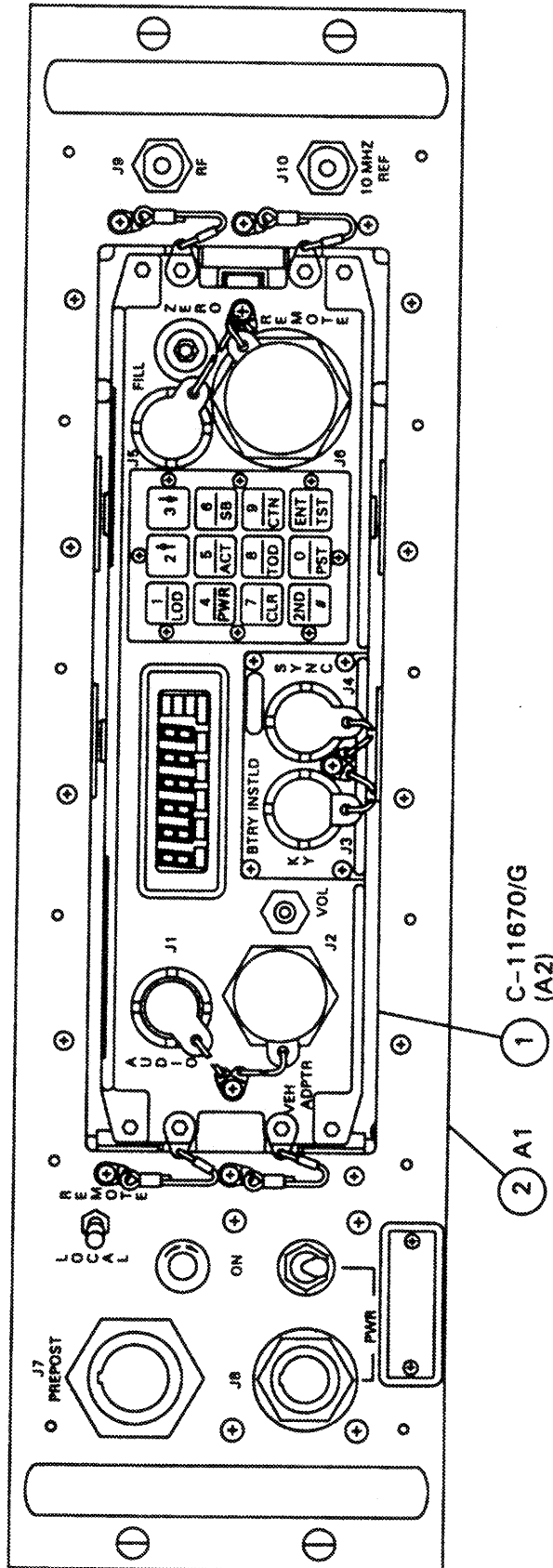

RECEIVER-TRANSMITTER FRONT PANEL VIEW

1-9. LOCATION AND DESCRIPTION OF MAJOR COMPONENTS (Cont.)

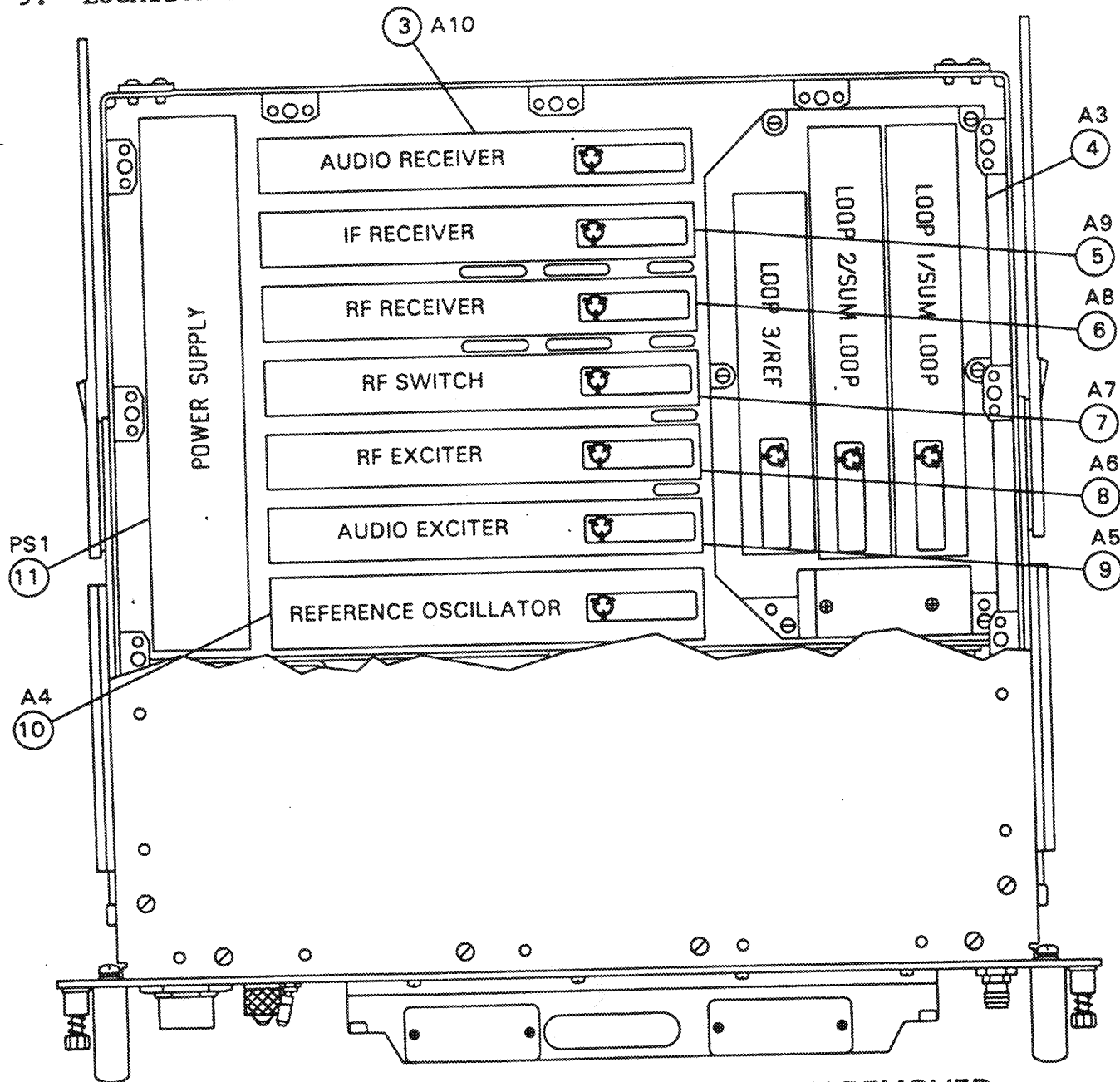

TOP VIEW OF RT WITH COVER PARTIALLY REMOVED

- ③ Audio Receiver A10. Contains circuitry to amplify and output the audio signal to ECCM module.
- ④ Frequency Synthesizer A3. Provides synthesized frequencies used to produce IF and upper or lower sideband operation.
- ⑤ IF Receiver A9. Contains circuitry to receive the IF signal and produce the audio signal.
- ⑥ RF Receiver A8. Contains circuitry to produce and amplify two levels of IF.

1-9. LOCATION AND DESCRIPTION OF MAJOR COMPONENTS (Cont.)

- ⑦ RF Switch A7. Provides for filtering and routing of the received and transmitted RF signals and inputs the RF BIT signal to the receiver circuits.
- ⑧ RF Amplifier Exciter A6. Contains circuitry for mixing the IF audio and a synthesized frequency to produce and amplify the desired RF signal for transmission.
- ⑨ Audio Sideband Exciter A5. Contains circuitry for modulating the audio signal to an IF signal for amplification.
- ⑩ Reference Oscillator A4. Provides the stable, accurate frequency required by the frequency synthesizer and RT operation. Also provides status information (BIT) when polled by the ECCM module.
- ⑪ Power Supply PS1. Provides the power requirements of the RT

1-10. IDENTIFICATION AND INSTRUCTION PLATES

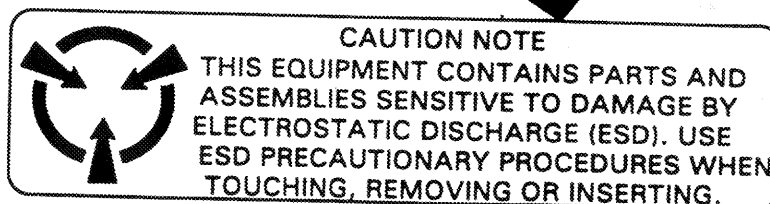
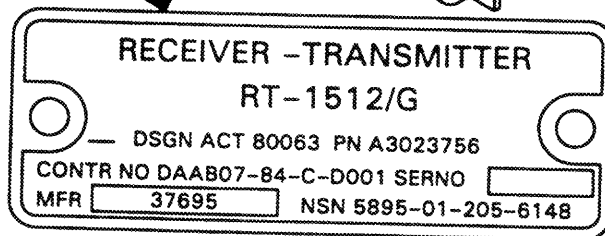
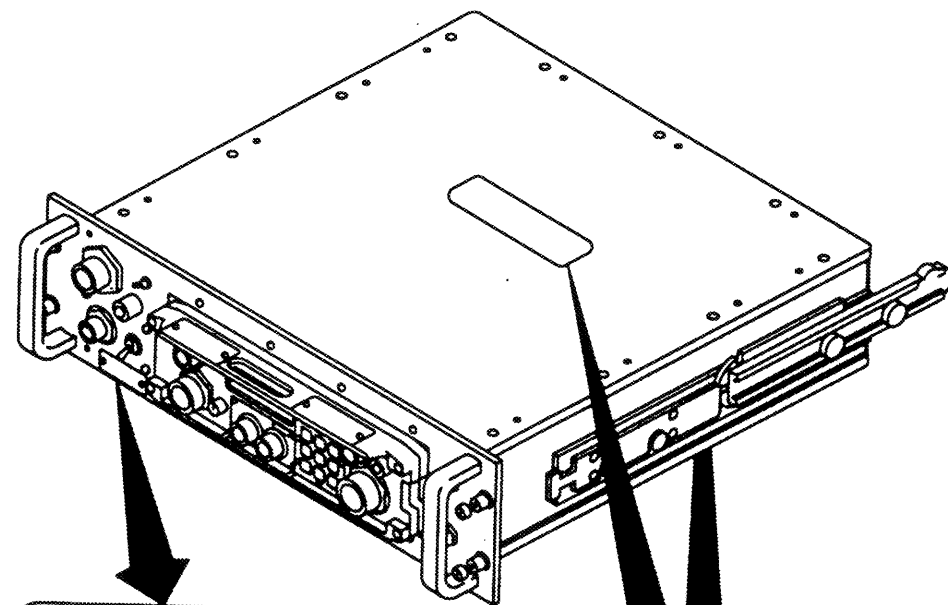

1-11. EQUIPMENT DATA

a. Technical Characteristics:

Frequency range 2.0000 to 29.9999 MHz
 Number of channels 280,000
 Channel spacing Selectable in 100 Hz steps,
 tunable in 100 Hz steps
 Communications Voice and data
 Modes ECCM, Non-ECCM, upper-sideband/
 lower-sideband (USB/LSB), data,
 voice, and CW
 Frequency stability ... 2 x 10⁶ Hz (2 parts per million
 (PPM)) over 6 months at all
 temperatures
 Input voltage 103 to 126 Vac, single-phase,
 47 to 440 Hz, 65 VA nominal
 Output power 100 mW PEP nominal
 Sensitivity (10 dB S+N/N) -110 dBm

Selectivity

<u>Attenuation</u>	<u>Upper Sideband</u>	<u>Lower Sideband</u>
3 dB	Carrier +300 to +3150 Hz	Carrier -300 to -3150 Hz
60 dB	Carrier -400 to +4400 Hz	Carrier +400 to -4400 Hz

Audio output 0.01 to 2 mW, 1000 Ohm (voice
 with volume control) 0 dBm, 600 Ohm
 (data)
 Audio distortion 10% maximum
 Audio input H-356/G handset compatible (voice)
 0 dBm, 150 ohm (data)
 Duty cycle 100%

Spurious output

Suppressed carrier .. 40 dB below PEP
 Unwanted sideband ... 45 dB below PEP

1-11. EQUIPMENT DATA (Cont.)

Intermodulation 30 dB below PEP for two equal
amplitude tones
Harmonics 25 dB below PEP
Other spurious 70 dB below PEP
Frequency response

<u>Attenuation</u>	<u>Upper-Sideband</u>	<u>Lower-Sideband</u>
3 dB	Carrier +300 to +3150 Hz	Carrier -300 to -3150 Hz
60 dB	Carrier -400 to +4400 Hz	Carrier +400 to -4400 Hz

Continuous tone modulation ... 1000 (850 to 1150) Hz

b. Physical Characteristics:

Width 17.4 inches
Height 4.5 inches
Depth 15.8 inches
Weight 39.5 lb

1-12. SAFETY, CARE, AND HANDLING

WARNING

Receiver-Transmitter RT-1512/G weighs more than 39 pounds. Two persons are required for lifting and handling this unit.

CAUTION

Prior to removing or installing a component or cable, ensure that power to the component has been turned off. Removing and connecting cables while power is applied may result in an arc or short. This can produce damage to the connector pins.

The RT contains certain static-sensitive solid state devices which are subject to damage from electrostatic discharge (ESD). Effective control of ESD is maintained only through continuous strict observance of the following maintenance procedures.

1-12. SAFETY, CARE, AND HANDLING (Cont.)

- Any maintenance requiring disassembly of the must be performed at an approved work station. The work station must include a grounded surface and grounded wrist strap in accordance with DOD-HDBK-263.
- All maintenance personnel must have completed training in the handling of static-sensitive devices before working on this equipment. Maintenance personnel must wear the grounded wrist strap and be at an approved work station when performing maintenance.
- The static sensitive subassemblies or circuit cards must be stored in approved electrostatic free material when not installed in the equipment.

Make all cable connections by hand. Do not use tools.

Section III. PRINCIPLES OF OPERATION

1-13. GENERAL

a. The RT consists of 11 functional assemblies:

- Chassis Assembly A1
- ECCM Module A2
- Frequency Synthesizer A3
- Reference Oscillator A4
- Audio Sideband Exciter A5
- RF Amplifier Exciter A6
- RF Switch A7
- RF Receiver A8
- IF Receiver A9
- Audio Receiver A10
- Power Supply PS1

b. These assemblies, except for the chassis assembly A1, are housed in the chassis assembly and interconnected to the Regency Net (RN) system through front panel connectors J7, J8, J9, and J10. The ECCM module, which is mounted in the front panel of the receiver, contains connectors J1 through J6.

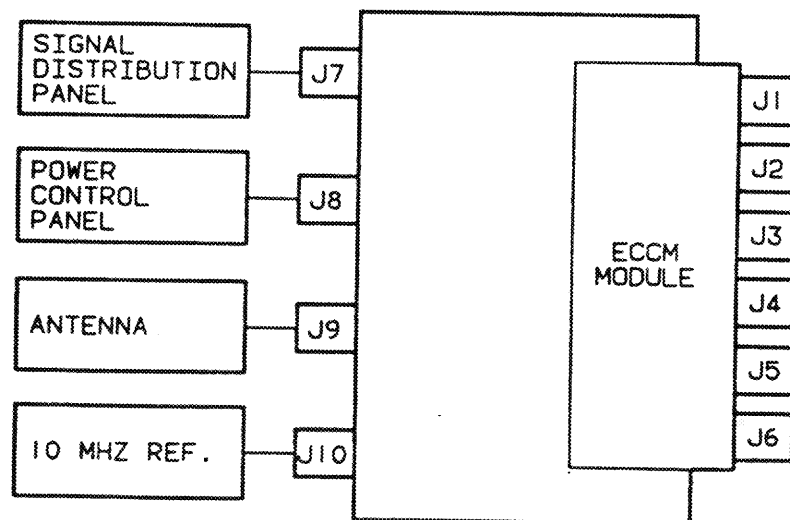

RT-1512/G

1-13. GENERAL (Cont.)

- (1) J7, PREPOST. Connect the RT to the pre/post selector and the power amplifier. Outputs to the pre/post selector are frequency select lines and pre/post selector override. Inputs from the pre/post selector are the pre/post selector status. Outputs to the power amplifier are the power reduction control signals. Inputs from the power amplifier are the power amplifier status, forward power sample, and the reflected power sample signals.
- (2) J8, PWR. Power connector for the unit. Inputs are 115 Vac, 115 Vac neutral, and chassis ground.
- (3) J9, RF. The rf signal, from the pre/post selector, is received on this line.
- (4) J10, 10 MHZ REF. The 10 MHZ reference signal, from the reference frequency oscillator (RFO) is received on this line.
- (5) ECCM J1, AUDIO. Connects the RN voice audio signals (transmit and receive) from the signal entry panel (SEP) to the RT/ECCM. Other inputs to this connector are the push-to-talk line and audio compression disable. In addition to accepting signals from the SEP, this connector will also accept signals directly from the H-356/G handset.
- (6) ECCM J2, VEH ADPTR. The vehicle adapter connector is not used with the RT in the Force Terminal application.
- (7) ECCM J3, KY. This connector is not used with the RT in the Force Terminal application.
- (8) ECCM J4, SYNC. Connects the delayed push-to-talk signal from the RT/ECCM to the KY-75A through the SEP.
- (9) ECCM J5, FILL. Connects a fill device, such as the KYK-13 or KOI-18, for the input of data to the ECCM module. Input signals include ground, data, and clock.
- (10) ECCM J6, REMOTE. Connects the RT/ECCM to the antenna tuning unit (ATU), the modem, and the control interface unit (CIU). The ATU signals include tuning signals and VSWR selects. Outputs to the modem are receive audio and a serial control data pair from the ECCM module. Inputs from the modem are transmit audio, push-to-talk (keyline), automatic gain control (AGC), external clock enable, hop clock, and a serial control data pair to the ECCM module. An output to the CIU is the status bus. Inputs from the CIU include RT identification (established by ground wires in the cable), control bus, and a 1 pulse per second timing signal.

1-14. FUNCTIONAL DESCRIPTION OF RECEIVER-TRANSMITTER

a. The RT is a SSB receiving and transmitting radio operating in the HF band (2.0000 to 29.9999 MHz). The RT is USB or LSB SSB operation, and remote control operation. The RT functional block diagram shows the various interconnections of the RT (including the ECCM module).

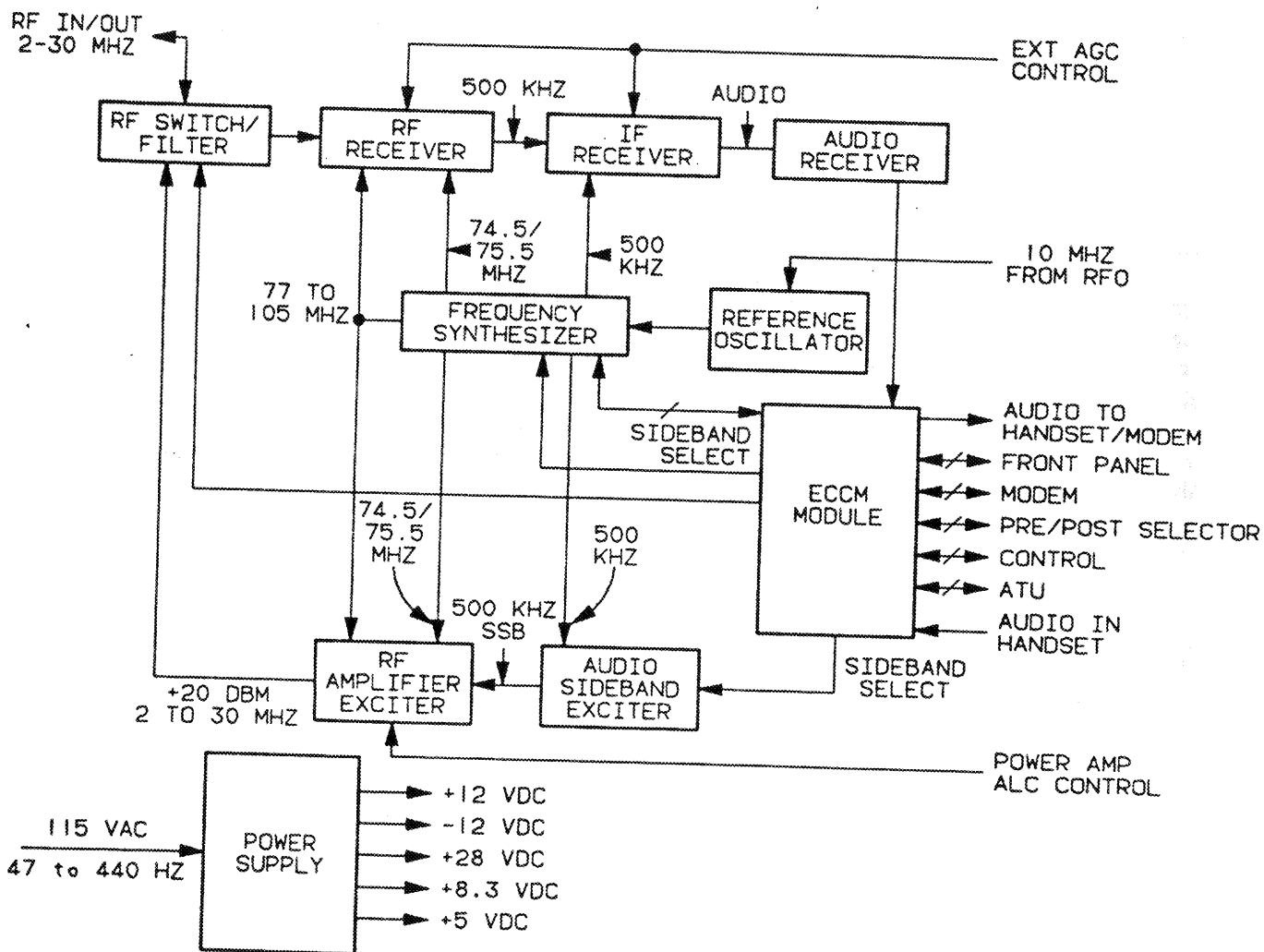

1-14. FUNCTIONAL DESCRIPTION OF RECEIVER-TRANSMITTER (Cont.)

b. In the receive mode, the RT amplifies and filters incoming rf signals and converts them to baseband signals. The baseband signals are then provided as outputs to the system components.

c. In the transmit mode, the RT accepts data, encrypted voice, or plain voice signals from the system components and impresses them on an rf carrier by single-sideband modulation techniques. The modulated rf signal is then translated to the desired operating frequency and amplified to a nominal 100 mW PEP.

d. The RT controls the rf output level using feedback signals from the system. An rf power output level of 25, 100, or 400 watts may be selected. The output level is maintained to within ± 1 dB of the selected level by a feedback voltage from the system to the RT.

e. The ECCM module controls the RT. It plugs into and becomes an integral part of the RT. All radio functions, including operating frequency, power level, and sideband, are selected at the keypad on the ECCM module. Operating frequency and mode are displayed on the ECCM module's liquid crystal display (LCD). Remote control of the RT functions are provided through the ECCM remote control connector to the system. When controlled remotely, the ECCM module keyboard and display are disabled.

f. The RT has circuits that isolate faults to the assembly level. The ECCM module controls/displays BIT. BIT status is also outputted to the system. The RT performs two BIT fault isolation tests.

g. On-line BIT is performed once every second in receive and transmit modes. The on-line BIT evaluates the ECCM module, power supply, reference oscillator, and frequency synthesizer modules. The audio sideband exciter, rf amplifier exciter, and rf switch assemblies are not tested by on-line BIT.

h. The off-line BIT is performed when the RT is powered up, when requested from the system, or when the test button (on ECCM) is depressed (in local mode only). Off-line BIT is a more thorough fault isolation test of the RT. The off-line BIT performs the same checks as on-line BIT on the audio sideband exciter, rf amplifier exciter, and rf switch assemblies. It performs the same checks as on-line BIT and additional BIT checks on the ECCM module, reference oscillator, and frequency synthesizer. Additionally, off-Line BIT checks the rf receiver, if receiver, and audio receiver, and audio switching assembly in the ECCM.

i. BIT uses fault priority to display a fault number on the ECCM. With multiple faults the highest priority fault number is shown first. Subsequent faults are displayed by pushing the "ENTER" button on the ECCM keypad. After all faults are shown, the first fault is shown again.

1-15. FUNCTIONAL DESCRIPTION OF MAJOR COMPONENTS

a. Chassis Assembly (A1). The chassis assembly provides the mounting and protection for the internal components of the RT. The chassis assembly has circuit cards, ribbon wiring harnesses, filters, connectors, and RF cable assemblies to interconnect the assemblies in the RT. The chassis interconnect wiring diagram is shown in figures FO-1, FO-2, and FO-3 in the foldout section in the back of the manual.

b. ECCM Module (A2). The ECCM module provides all control and display functions for the RT and supports each of the ECCM modes in the system. The ECCM module controls radio operating frequency, radio power output level (low, medium, and high), and radio sideband operation (USB or LSB) and synchronizes the encryption device with radio operation. The ECCM module accepts full function remote control data from the system for remote control of the radio. The ECCM module displays operating frequency and mode on an LCD. When controlled remotely the keypad and display are disabled. The ECCM module performs two-way transfer of tuning and transmit/receive mode information to the system. The ECCM module accepts time-of-day (TOD) information from and passes information to the reference oscillator.

c. Frequency Synthesizer (A3). The frequency synthesizer provides synthesized frequencies to produce IF and USB or LSB operation. The frequency synthesizer receives a reference frequency signal from the reference oscillator. From this stable frequency, it creates various other frequencies required to process rf signals received and transmitted. Digital signals, from the ECCM module, which control latching circuits in the frequency synthesizer determine the signals created.

d. Reference Oscillator (A4). The reference oscillator contains two separate circuit cards, the reference oscillator circuit card and the status circuit card. The reference oscillator circuit card receives the reference frequency signal, through the RT front panel from the system input connector, and checks the amplitude of the reference frequency. If above a predetermined level, the reference oscillator circuit card passes the reference frequency signal on to the frequency synthesizer. If below a predetermined level, the reference oscillator circuit card turns its own local oscillator ON and passes that reference frequency signal to the frequency synthesizer. The reference oscillator circuit also turns ON a predetermined BIT frequency during off-line BIT. The status circuit card serves as a centralized location for reporting status information to the ECCM module during both on-line and off-line BIT and latches the tuning information which is outputted for the operating mode selection.

1-15. FUNCTIONAL DESCRIPTION OF MAJOR COMPONENTS (Cont.)

e. Audio Sideband Exciter (A5). The audio sideband exciter contains circuitry to modulate the audio signal to an IF signal for amplification. The audio signal from the audio input connector goes through the ECCM into the audio sideband exciter (SSB modulator). In the SSB modulator, a 500 KHz signal is modulated with the audio signal and produces a double sideband suppressed carrier signal. The double sideband suppressed carrier signal goes to a sideband filter to select the upper-sideband signal. The 500 kHz upper-sideband signal is amplified and outputted to the rf amplifier exciter.

f. RF Amplifier Exciter (A6). The rf amplifier exciter circuitry mixes the 500 KHz upper-sideband signal and a synthesized frequency to produce and amplify the rf signal for transmission. The RF amplifier exciter receives the modulated signal from the audio sideband exciter. The rf amplifier exciter up-converts the upper-sideband modulated audio signal to a nominal 75 MHz. The injection signal will be 75.5 MHz if the output signal is upper-sideband, or 74.5 MHz if the output signal is lower-sideband. The 75 MHz is filtered and amplified. The rf amplifier exciter down-converts the 75 MHz signal to a 2.0000 to 29.9999 MHz band by mixing with the synthesizer frequency of 77.0000 to 104.9999 MHz. The output rf signal is amplified to approximately +20 dBm and passed to the rf switch.

g. RF Switch (A7). The rf switch filters and routes the receive and transmit rf signals. In receive mode, incoming rf from the antenna input connector goes through the rf switch transmit/receive circuit to the rf receiver. The rf switch has a 2 to 30 MHz filter circuit to filter the input rf. In transmit mode the output rf signal from the rf amplifier exciter (transmitter) goes through the rf switch transmit/receive to the output connector. The rf switch has a 2 to 30 MHz filter circuit to filter the output rf. The receive BIT rf is input to the receiver circuits through the rf switch.

h. RF Receiver (A8). The rf receiver has circuitry which produces and amplifies two levels of IF. The rf receiver receives the 2 to 30 MHz rf signal from the rf switch. The rf signal is mixed with the synthesizer local oscillator signal. The local oscillator operates in the frequency band of 77 to 104.9999 MHz. The mixing action up-converts the input rf signal to the first IF level frequency of 75 MHz. The first IF signal is amplified and down converted to the second IF level frequency of 500 kHz. The injection signal for this operation is 75.5 MHz, if the incoming signal is upper-sideband or 74.5 MHz, if the incoming signal is lower-sideband.

i. IF Receiver (A9). The sideband filtering is accomplished at the 500 kHz IF. The IF receiver has circuitry to receive the IF signal and produce the audio signal. The IF receiver receives the 500 kHz IF sideband signal from the rf receiver and amplifies it. The IF receiver mixes the 500 kHz IF sideband signal with a 500 kHz local oscillator signal which translates the sideband signal to an audio signal. The audio signal is passed on to the audio receiver.

1-15. FUNCTIONAL DESCRIPTION OF MAJOR COMPONENTS (Cont.)

j. Audio Receiver (A10). The audio receiver circuitry is used to amplify and output the audio signal. The audio receiver receives the audio signal from the IF receiver and amplifies it. The audio receiver passes the audio signal to either the handset or modem connector. These connections are through the ECCM module.

k. Power Supply (PS1). Refer to figure FO-4. The power supply (PS) provides the power for the RT. The PS converts the 115 Vac, 47 to 440 Hz input voltage to the rectified, filtered, and regulated dc voltage outputs. The voltage outputs are +12 Vdc, -12 Vdc, +28 Vdc, +8.3 Vdc, and +5 Vdc. The PS also has a BIT (+3.5 to +5.5 Vdc) output (PS FAULT). There are overcurrent protection circuits for each of the voltage supply outputs. The PS is a switching type with pulse width modulation, an output supervisory chip, full wave rectification, electromagnetic pulse (EMP)/crowbar protection circuitry, and surge current protection. Power input to the RT comes through connector J1 and FL1, mounted as one unit to the front panel, before being routed to the PS.

- (1) The PS consists of a chassis and two circuit card assemblies (CCA). All the electrical circuits are on the CCAs except for the +5 volt regulator, which is mounted on the chassis. The CCAs are the regulator output assembly, PS1A3, and the ac to dc inverter assembly, PS1A2. The A3 assembly contains both the power input connector, A3P1, and the power output connector, A3P2. Figure FO-4 is a functional block diagram of the PS.
 - (a) AC power to the PS is first rectified and then applied to a voltage doubling circuit. The dc output from this circuit is applied to an auxiliary supply circuit which produces a 20 kHz output that is rectified and filtered to provide the voltage collector current (Vcc) operating voltage. This Vcc voltage is used to power the control circuit, PS supervisory control circuit, and overvoltage and undervoltage comparator circuits.
 - (b) The main function of the PWM is to provide positive pulses, at 40 kHz, to the driver circuit. By monitoring the +8.3 volt PS and varying the width of the positive output pulses, the output voltage levels of the dc supplies are controlled. The PS FAULT voltage is also supplied by the PWM.
 - (c) The pulsed output of the PWM is applied to the driver circuit, also referred to as a half bridge inverter. Here the pulses are amplified and inverted to provide both plus and minus pulses to the power transformer. The frequency of these pulses is 40 kHz.

1-15. FUNCTIONAL DESCRIPTION OF MAJOR COMPONENTS (Cont.)

- (d) (Refer to Figure FO-5) The power transformer contains three secondary windings which are used to provide four dc output voltages. These voltages are the +12 V, -12 V, +28 V, and +8.3 V.
 - (e) Full wave rectifier circuits, with primary center tapped windings in each circuit, are used in each of the PS voltage outputs. Each of the four voltage supplies have current limiting detection circuits. The circuits derive their inputs from the transformers, whose primary windings are in the rectifier circuits.
 - (f) Inductors, having a common core, in each voltage supply along with capacitors and resistors provide filtering for each of the four power supply voltages.
 - (g) The +5 Vdc power supply is a regulated supply using the +8.3 V supply as its input.
 - (h) Each PS except for the +5 V supply, has its own crowbar protection circuitry. The +5 V supply is protected by and also tapped into the +8.3 V supply crowbar protection circuit.
 - (i) Overvoltage and undervoltage comparators are provided for each PS except for the +8.3 V supply. PS control is keyed from the +8.3 V supply; changes in its voltage are used by the PWM to provide this control.
 - (j) The PS supervisory control circuit receives inputs from the overvoltage/undervoltage comparator circuits where 1) an undervoltage indication grounds the PS FAULT signal and 2) an overvoltage indication provides a signal to the PWM which cuts off any output to the driver circuit, which effectively cuts off any output from the PS. Signals from the current limiting circuits are input to the PS supervisory control circuits. An output from the supervisory circuit to the PWM results in lowering the voltage levels of all the power supplies.
- (2) A detailed discussion on the theory of operation of the PS is provided below. Schematics for this discussion are provided in figures FO-5 and FO-6.
- (a) Surge Current Limiting. Thermistor A3R1, at the PS input, is connected in series with the power line for limiting the turn-on surge current.

1-15. FUNCTIONAL DESCRIPTION OF MAJOR COMPONENTS (Cont.)

- (b) Voltage Spike Clamping. Transorber A3VR1, across the power input lines, clamps the voltage input at an upper limit. This effectively cuts off any high voltage spikes on the input voltage line getting into the power supply.
- (c) Rectifier and Voltage Doubler. This circuit consists of diodes A3CR1 and A3CR2 for rectification, capacitors A3C1 and A3C2 as "bulk" capacitors for voltage doubling, and bleed resistors A3R2 through A3R5 for loading and for bleed off of the capacitors at power turn off.
- (d) Auxiliary Power Supply. The auxiliary power supply, also called a dc inverter circuit, is formed by A2Q1 and A2Q2. This circuit switches the input power from the voltage doubler circuit (paragraph k(3)) through the primary windings of A2T1 to feed the input stage. When power is applied, A2Q1 begins to conduct and induces a current flow in the primary of A2T1. The core of A2T1 is saturated. At saturation, the inductance of the transformer windings decreases rapidly and begins to reverse polarity. The change in polarity causes current to reverse in the base circuit, through diodes in the conduction stage, causing the conducting transistor to shut off. At the same time, current in the base circuit of the non-conducting transistor (A2Q2) increases, causing it to conduct. This induces voltage of the opposite polarity into the windings of A2T1. This action results in alternating current produced in the primary windings of A2T1 at 20 kHz. The resistor-capacitor networks (A2C1, A2R1, A2R2 and A2C4, A2R6, and A2R7), along with the diodes in the base circuits of the transistors, provide paths for rapid base bias changes. Capacitors A2C2 and A2C3 provide the high frequency common return line from pin 2 of transformer A2T1.

- Output voltage from the secondary windings of A2T1 is rectified by a full wave bridge rectifier, formed by diodes A2CR11, A2CR12, A2CR13, and A2CR14. DC filtering is provided by A2C6, A2C7, and A2R9. The auxiliary PS provides operating voltage (Vcc) of approximately 13.4 Vdc for control circuits within the PS.
- A crowbar protection circuit is provided by the network of A2C8, A2CR15, A2R10, and A2Q3. When A2CR15 conducts it allows A2Q3 to conduct, and when A2Q3 is triggered, it grounds the auxiliary PS output (Vcc). This results in a shutdown of all PS supply voltage outputs. Power to the PS must be cycled off and on to reset A2Q3.

1-15. FUNCTIONAL DESCRIPTION OF MAJOR COMPONENTS (Cont.)

(e) Pulse Width Modulator. The output voltage levels of the PS are controlled by pulse width modulator (PWM) A2U1. The PWM operates from Vcc and has an internal amplifier, an error amplifier, and a reference voltage regulator. Resistor A2R13 and capacitor A2C10 provide the time constant to run an oscillator in the PWM. External compensation and error correction are provided through A2R14, A2C11, and comparator amplifier A2U2B. Voltage regulator A2VR1 clamps the comparator output voltage at 5.1 Vdc to prevent damage from high voltage to A2U1. The +8.3 Vdc PS output is used as an input to comparator A2U2B through a voltage divider.

- Vcc is applied to A2U1 through A2R11 at pin 13 and directly to A2U1 at pin 15. Vin (pin 15 input) is monitored in A2U1 for undervoltage. If undervoltage occurs, operation of A2U1 is shut down. Vin is also regulated internally in A2U1 to establish a reference voltage for internal/external use. The REF voltage output at A2U1 pin 16 provides the PS FAULT power supply output. This output is normally +3.5 Vdc to a maximum of +5.5 Vdc. However, if an undervoltage is detected in supervisory control circuit A2U3, the REF output of A2U1 is grounded and the PS FAULT signal voltage drops to less than +1.5 Vdc.

- Outputs A, pin 11, and B, pin 14, of A2U1 are 40 kHz positive going pulses from the Vcc level of 13.4 volts. These pulses are applied to the primary windings of transformer A2T2. The secondary of transformer A2T2 is used in the PS driver circuit, also referred to as a half bridge inverter. A2U1 varies the widths of the positive pulses to control PS output voltage levels. Narrower pulses reduce PS output voltage levels and wider pulses increase the PS output voltage levels.

(f) Driver Circuit. The 40 kHz pulses applied to transformer A2T2 alternately gate MOSFETS A2Q8 and A2Q9 off and on. A2Q8 conducts when pin 3 of A2T2 is positive and A2Q9 conducts when pin 5 of A2T2 is negative. When A2Q8 is conducting, positive dc voltage from the voltage doubler circuit (paragraph k(3)) passes through A2L2, A2Q8, A2C30, and to transformer A3T2. When A2Q9 is conducting, negative voltage is applied through A2L1, A2Q9, and A2C30 to transformer A3T2. Therefore, the voltage applied to A3T2 is at 40 kHz. Transorbers A2VR2 and A2VR3 of the driver circuit clamp A2Q8 and A2Q9 base voltages to 13 Vdc, a safe level to prevent damaging A2Q8 and A2Q9. Capacitor A2C30 is used to block any dc level voltages from A3T2.

1-15. FUNCTIONAL DESCRIPTION OF MAJOR COMPONENTS (Cont.)

- (g) Power Transformer. Power transformer A3T2 receives its input from the driver circuit at pin 1 of the primary winding. Pin 2 of the primary winding returns through the primary winding of A3T3 to the neutral power input line of the power supply.
- There are three sets of secondary windings of the power transformer A3T2. Each winding is center-tapped and connected together for a common line that is carried throughout the power supply.
 - One secondary winding of A3T2 (pins 3, 4, and 5) is used to provide voltage for plus and minus 12 Vdc supplies. Another A3T2 secondary winding (pins 6, 7, and 8) supplies the +28 Vdc. The third secondary winding (pins 9, 10, and 11) supplies the +8.3 Vdc.
- (h) Power Supplies. A full wave rectifier, consisting of a transformer and two diodes, is in the circuit of each secondary of power transformer A3T2. The center tap of the primary winding of each transformer is the output line for each PS. These rectifiers consist of A3T4, A3CR7, and A3CR8 for the +12 Vdc supply; A3T5, A3CR9, and A3CR10 for the -12 Vdc supply; A3T6, A3CR15, and A3CR16 for the +28 Vdc supply; and A3T7, A3CR19, and A3CR20 for the + 8.3 Vdc supply.
- Each of the Power Supplies has a common core inductor, A3L3, in its output line. This choke, along with capacitors and resistors, provides a filter network for each supply.
 - The output of the +8.3 Vdc supply is input to a linear regulator A1U1 (mounted on the PS chassis). Resistor A2R56 is selected (select-at-test) to provide an accurate +5 Vdc output at pin C of A1U1. Diode A2CR24 allows large voltage spikes, to pass through it to the crowbar circuitry of the +8.3 Vdc supply. The +5 Vdc output at A1U1 - C (TO-3 Case) is routed to pin F of connector A3P2 as the +5 Vdc PS output.

1-15. FUNCTIONAL DESCRIPTION OF MAJOR COMPONENTS (Cont.)

- (i) Crowbar Protection Circuits. Crowbar protection circuits, similar to that described for the auxiliary PSs, are provided for each output PS. These consist of A2Q6 and A2CR20 for the +12 Vdc supply, A2Q7 and A2CR21 for the -12 Vdc supply, A2Q5 and A2CR19 for the +28 Vdc supply, and A2Q4 and A2CR18 for the +5 Vdc and +8.3 Vdc supplies.
- (j) Current Limiting. The current limiting circuits for each of the four PSs and for power transformer A3T2 are identical. Each of these circuits contains a "select-at-test" resistor (A3R12, A3R14, A3R16, A3R20, and A3R23) to provide the desired voltage output of the current limiting circuit. The PSs use the secondary windings of transformers A3T4 through A3T7, while the secondary winding of A3T3 is used for current limiting of A3T2. Each of the current limiting circuits contains an RC filter network and two diodes for rectification to positive dc volt outputs (including the -12 Vdc supply). As excessive current is drawn in the PS or power transformer, it is reflected into the winding in the current limiting circuit. This causes higher voltage in the winding, which in turn causes higher voltage across the "select-at-test" resistor. The voltage outputs of all the current limiting circuits are connected to a voltage divider network consisting of A2R17 and A2R19. This voltage, applied to pin 2 of current limiter A2U2A, increases, causing the output of A2U2A to go low. This biases A2CR16 low to allow current (from Vcc voltage) through A2R29 to pass through it and through voltage divider network A2R21 and A2R22. The increased current through A2R29 causes a voltage reduction at the non-inverting (NI) input, pin 11, of supervisory chip A2U3. Operation of the supervisory chip will be explained in subsequent paragraphs.
- (k) Overvoltage/Undervoltage Sensing. The +12 Vdc, -12 Vdc, +28 Vdc, and +5 Vdc PS outputs are connected to overvoltage and undervoltage comparators as follows:
- +12 Vdc -- Undervoltage comparator A2U5A (+)
-- Overvoltage comparator A2U5B (-)
 - -12 Vdc -- Undervoltage comparator A2U5C (-)
-- Overvoltage comparator A2U5D (+)
 - +28 Vdc -- Undervoltage comparator A2U4A (+)
-- Overvoltage comparator A2U4B (-)
 - +5 Vdc -- Undervoltage comparator A2U4C (+)
-- Overvoltage comparator A2U4D (-)

1-15. FUNCTIONAL DESCRIPTION OF MAJOR COMPONENTS (Cont.)

The undervoltage comparator outputs are tied together and connected to PS supervisory chip A2U3 at overvoltage (OV) input, pin 6, and, through voltage divider network resistor A2R32, at undervoltage (UV) input, pin 7. The signal to the OV input of A2U3 has no effect on its operation. The signal at the UV input of A2U3 causes its output at undervoltage indicate (UV IND), pin 9, to go to ground. A ground at pin 9 causes the PS FAULT line at A3P2-B to go low (that is, less than +1.5 Vdc).

- The overvoltage comparator outputs go low with an overvoltage condition. The outputs are tied together and connected to PS supervisory chip A2U3 at overvoltage indicate (OV IND) input (normally an output), pin 4 and to the cathode of A2CR17. The low applied to A2CR17 biases it on to provide a ground at the remote activate (REM ACT) input, pin 2, of A2U3. Grounding this pin causes a ground at pin 4 (OV IND) which latches A2CR17 at ground to maintain the overvoltage condition. Also, a silicon controlled rectifier (SCR) in supervisory chip A2U3 is triggered and latched to provide a +13 Vdc output at pin 1 SCR. This voltage is applied to current limiting amplifier A2U2A, which will be discussed in subsequent paragraphs (supervisory circuit).

- Note that the +8.3 Vdc PS output is not connected to a voltage comparator. Instead, it is connected through a voltage divider network of resistors A2R18, A2R25, A2R26, and A2R28. A tap off of the divider network between A2R25 and A2R26 is applied to pin 6 of the integrator amplifier A2U2B. Voltage changes, both plus and minus, in the +8.3 Vdc supply are amplified in A2U2B and output at pin 7 to the NI input, pin 2, of the PWM A2U1. Voltage level inputs at the NI input of the PWM chip are used to adjust the output pulse widths at A and B, pins 11 and 14 respectively. Thus the overall voltage level of all the PS are keyed off the voltage level of the +8.3 Vdc supply. Potentiometer A2R28 is used to adjust the operating voltage level to pin 6 of integrator amplifier A2U2B.

1) Supervisory Circuit. The PS supervisory chip, A2U3, controls various PS functions. Its input voltage is 13.4 Vdc from the auxiliary PSs. It contains a reference voltage generator (2.5 Vdc), a current limiting amplifier, voltage comparison (overvoltage and undervoltage) amplifiers, and a latching SCR trigger. The SCR is triggered by an overvoltage signal as explained previously. Overvoltage and undervoltage indication outputs are provided. The voltage drop at the NI input,

1-15. FUNCTIONAL DESCRIPTION OF MAJOR COMPONENTS (Cont.)

resulting from an over current condition described in the current limiting paragraph, causes a lowering of voltage at pin 13 (OUT), which is applied to pin 5 of integrator amplifier A2U2B. The output of this integrator goes high and is input at pin 2 (NI) of A2U1. The high input at NI of the PWM results in narrower pulse outputs from the PWM that cause reduced PS output voltages. If the supply outputs are reduced enough to cause sensing of an undervoltage condition, the PS FAULT signal will indicate a power supply fault, as discussed previously.

CHAPTER 2 UNIT MAINTENANCE

<u>Subject</u>	<u>Page</u>
Preparation for Storage or Shipment	2-18
Preventive Maintenance Checks and Services (PMCS)	2-4
Repair Parts, Special Tools; Test, Measurement, and Diagnostic Equipment (TMDE); and Support Equipment	2-1
Service Upon Receipt	2-2
Unit Maintenance	2-8
Unit Troubleshooting	2-6

Section I. REPAIR PARTS, SPECIAL TOOLS; TEST, MEASUREMENT, AND DIAGNOSTIC EQUIPMENT (TMDE); AND SUPPORT EQUIPMENT

2-1. COMMON TOOLS AND EQUIPMENT

a. Army. For authorized common tools and equipment, refer to the Modified Table of Organization and Equipment (MTOE) applicable to your unit.

b. Navy. Navy personnel refer to applicable Tables of Allowance (TA).

c. Air Force. Air Force personnel refer to applicable Tables of Allowance (TA).

2-2. SPECIAL TOOLS, TMDE, AND SUPPORT EQUIPMENT

Special tools, TMDE, and support equipment and their purposes are listed in the Maintenance Allocation Chart, Appendix B.

2-3. REPAIR PARTS

Repair parts used during unit maintenance are listed and illustrated in the repair parts and special tools list located in TM 11-5895-1303-24P, (Navy) EE162-NG-PLD-010/W110-RT1512G, (Air Force) TO 31R2-4-562-4.

Section II. SERVICE UPON RECEIPT

2-4. UNPACKING

There are no special procedures for unpacking the RT. However, avoid damaging the container during unpacking operation and report the empty container through established supply channels or, if applicable, use it to package another, unserviceable RT.

2-5. CHECKING UNPACKED EQUIPMENT

a. Inspect the equipment for damage incurred during shipment. If the equipment has been damaged, report the damage on SF 364, Report of Discrepancy (ROD).

b. Check the equipment against the packing slip to see if the equipment is complete. Report all discrepancies in accordance with the instructions of DA Pam 738-750.

c. Refer to DA Pam 25-30 to see if your equipment has had any Modification Work Orders (MWO) applied.

2-6. PRELIMINARY SERVICING AND ADJUSTMENT OF EQUIPMENT

The receiver is installed in accordance with the instructions contained in the following communications terminal manuals.

AN/TRC-179(V)1, (V)3	(Army) TM 11-5895-1218-12 (Navy) EE150-LQ-OMI-010/W110-TRC179V (Air Force) TO 31R2-2TRC179-21
AN/TRC-179(V)2	(Army) TM 11-5895-1219-12 (Navy) EE150-LR-OMI-010/W110-TRC179V2 (Air Force) TO-31R2-2TRC179-1
AN/FRC-180(V)2	(Army) TM-11-5895-1302-12 (Navy) EE160-RH-OMI-010/W110-FRC180 (Air Force) TO 31R2-2FRC180-1

Before installing the receiver in the system, do the following preliminary checks.

a. Check all front panel connectors

- Connectors will be securely mounted to the chassis.
- Connector pins will not be bent or broken.
- Connectors requiring covers are present and on connectors not used.

2-6. PRELIMINARY SERVICING AND ADJUSTMENT OF EQUIPMENT (Cont.)

- b. Check all panel mounted switches and lamps.
 - Power indicator lamp will be installed in the dimmer lens.
 - Power indicator dimmer lens can be turned for blackout operation.
 - Power and LOCAL REMOTE switches are securely attached and operate freely.
- c. Check keyboard and BTRY INSTLD plate.
 - Keyboard is securely mounted to front panel.
 - Keys operate freely in keyboard, do not stick.
 - Contact the Intermediate General Support Maintenance to install battery.
- d. Check the general mechanical condition of the RT.
 - The front panel handles are securely mounted to the front panel.
 - The ECCM module is securely mounted into the RT.

Section III. PREVENTIVE MAINTENANCE CHECKS AND SERVICES (PMCS)

2-7. INTRODUCTION

Preventive maintenance procedures help maintain the equipment in a serviceable condition. They include items to be checked and procedures for checking them. When you are doing any PMCS or routine checks, keep in mind the WARNINGS and CAUTIONS about electrical shock and bodily harm. The checks and services described in the PMCS table outline inspections that are to be made at specific Weekly (W) and Monthly (M) intervals. A dot (•) in any INTERVAL column indicates the check and/or service that should be performed by the unit maintenance personnel at that time.

a. Routine Checks. The following items are not listed in the PMCS table. Defects that can be found by these checks should be reported and corrected when found.

- Cleaning
- Dusting
- Checking for frayed or loose cables
- Storing items when not in use
- Covering unused receptacles
- Checking for loose nuts, bolts, and screws

b. Explanation of Columns.

- (1) Item Number Column. This column is used as a source of item numbers for the TM Number Column on DA Form 2404, Equipment Inspection and Maintenance Worksheet, in recording results of PMCS.
- (2) Interval column. This column specifies the frequency of the check, M for Monthly checks and Q for Quarterly checks.
- (3) Item to be Inspected Column. This column specifies the item to be checked.
- (4) Procedures Column. This column describes the procedure by which the check is to be performed.

c. Instructions for Reporting and Correcting Deficiencies. If your equipment does not perform as required, refer to the troubleshooting procedures within this chapter. Report any malfunction or failures on the proper DA Form 2404, or refer to DA Pam 738-750.

2-7. INTRODUCTION (Cont.)

NOTE

If your equipment must be in operation all the time, only do items that can be checked and serviced without disturbing operation. Make the complete checks and services when the equipment can be shut down.

2-8. UNIT PMCS TABLE

PREVENTIVE MAINTENANCE CHECKS AND SERVICES

Item No.	INTERVAL		Item to be Inspected	PROCEDURE
	W	M		
1	•		End item equipment	Inspect for completeness
2	•		Communications Equipment Performance	Initiate terminal off-line BIT. If BIT fails, refer to troubleshooting procedures in Section IV, Chapter 2.
3	•		RT Front Panel and Chassis	Inspect for cracks, bends, or breaks. a. Remove defective part. b. Install serviceable part.
4		•	RT Front Panel and Chassis	Check that metal surfaces are free of corrosion. Spot paint bare surfaces that were previously painted. a. Sand area to smooth and remove corrosion. b. Touch-up paint area with small brush. c. Let dry before reassembly.

Section IV. UNIT TROUBLESHOOTING

2-9. GENERAL

Unit troubleshooting is limited to running both on-line and off-line BIT with the RT installed in the system and verification of the "Keep-Alive" battery in the ECCM. Refer to the applicable system operating manual, as listed below, for procedures for performing BIT.

<u>System</u>	<u>Manual</u>
AN/TRC-179(V)1 & 3	(Army) TM 11-5895-1218-12 (Navy) EE150-LQ-OMI-010/W110-TRC179V1 (Air Force) TO 31R2-2TRC179-21
AN/TRC-179(V)2	(Army) TM 11-5895-1219-12 (Navy) EE150-LR-OMI-010/W110-TRC179V2 (Air Force) to 31R2-2TRC179-1
AN/FRC-180(V)2	(Army) TM-11-5895-1302-12 (Navy) EE160-RH-OMI-010/W110-FRC180 (Air Force) TO 31R2-2FRC180-1

2-10. TROUBLESHOOTING PROCEDURES

If a fault is detected during BIT, "FAILED" will be shown on the ECCM module LCD and the small FAIL LCD will come on. Push the ENT (enter) key to display the fault code number. Fault code numbers and the corrective action to be taken are listed in the table on the next page.

- If a fault is detected, the FAIL indicator on the display will light and/or the display will show the message:



- Error codes (i.e. 50,51 etc.) shown on the display help to isolate the fault to a certain subassembly or system component.

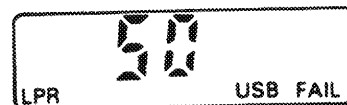

NOTE

The fault codes are used for different systems and also for levels of maintenance not covered in this manual. In these cases, the corrective action is "NA" (Not Applicable). Corrective action is listed only for maintenance actions covered in this manual.

2-10. TROUBLESHOOTING PROCEDURES (Cont.)

Fault Code	Corrective action
01 thru 19	NA
20 thru 32	Replace ECCM Module (para. 2-13)
33 thru 39	NA
40 thru 43	Replace ECCM Module (para. 2-13)
44 thru 49	NA
50 thru 51	Replace RT (See applicable system operating manual in para. 2-9 for replacement procedures)
52 thru 58	NA
59 thru 67	Replace RT (See applicable system operating manual in para. 2-9 for replacement procedures)
68 thru 79	NA

If, after performing the corrective action, there is still a fault indicated, contact Intermediate General Support maintenance.

Unit Level is authorized to remove and replace either the entire RT (including the ECCM) or the ECCM. If, after replacing the faulty unit, there is still a fault, contact Intermediate General Support.



b. Keep-Alive Battery (BA-1372/U). Check condition of battery by programming a preset frequency into the ECCM module. Remove power from the ECCM module for 5 minutes. Reconnect power and call up preset frequency just programmed. If frequency is not retained in memory, contact Intermediate General Support Maintenance to replace battery. Refer to TM 11-5895-1315-24 (C-11670/G) for battery replacement instructions.

Section V. UNIT MAINTENANCE

2-11. GENERAL

a. Unit Maintenance is authorized to replace a defective RT or ECCM based on BIT indications and perform a visual check for a defective thumbscrew, bow handle, lanyard assembly, incandescent lamp, or indicator lens lampholder.

b. Upon completion of a repair action and before returning the RT to service , initiate off-line BIT to verify operational status.

Initiate off-line BIT by pressing the  key and then  key on keypad.

The display shows:



and then:



and then:

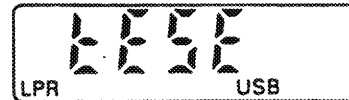

Upon successful completion of BIT, the display shows the frequency setting now in memory (last frequency used).

example:



If BIT was unsuccessful, the display will show:

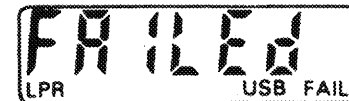

2-12. CLEANING

a. Use a dry, clean, lint-free cloth (item 1, Appendix C) or brush (item 2, Appendix C) to remove dust or dirt. When needed for the front panel of the unit, prepare a mild solution of water and a detergent having a mild degreaser (item 3, Appendix C). Dampen a lint-free cloth with the solution and wipe over the unit. When needed for the rest of the unit (not the front panel) wipe with a lint-free cloth dampened with water.

b. After cleaning wipe dry with a clean cloth.

2-13. REPLACEMENT OF THE ECCM MODULE C-11670/G

INITIAL SETUP

Tools

Wrench Hexagonal 5mm
Tool Kit TK-101/G
Static Control Service Kit

Equipment Condition

BIT Completed (para. 2-6, 2-10)
Power ON switch set to OFF.

Material/Parts

ECCM Module, C-11670/G, P/N A3023813

REMOVE ECCM MODULE

- STEP 1. Remove 4 recessed socket head screws ① from front of ECCM module ②. Screws ① will remain attached to RT front panel ③ by their lanyards ④.
- STEP 2. Pull ECCM module ② out of RT front panel ③ opening and remove from RT.

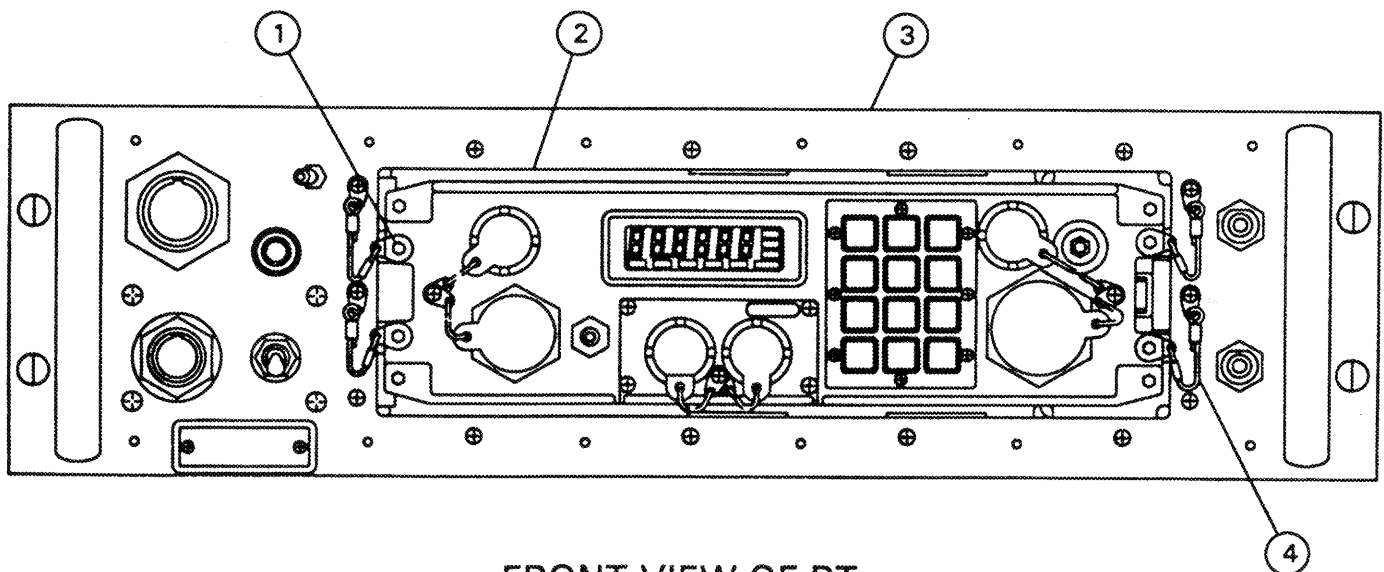

FRONT VIEW OF RT

REPLACE ECCM MODULE

- STEP 1. Insert the ECCM module ② in RT front panel ③.
- STEP 2. Position and screw in 4 recessed socket head screws ① securing ECCM module ② in RT front panel ③.
- STEP 3. Perform BIT to verify that RT and ECCM are operational.

2-14. REPLACEMENT OF INCANDESCENT LAMP OR INDICATOR LENS LAMPHOLDER

INITIAL SETUP

Material/Parts

Indicator Lens Lampholder, P/N LC36GD2,
or Incandescent Lamp, P/N MS25237-387

Equipment Condition

Power ON switch set to OFF.

NOTE

Use this procedure to replace either the incandescent lamp or the indicator lampholder or both.

REMOVE INCANDESCENT LAMP OR INDICATOR LENS LAMPHOLDER

- STEP 1. Unscrew indicator lens lampholder ① from lamp socket on front of RT panel ②.
- STEP 2. Remove incandescent lamp ③ from indicator lens lampholder ①. Retain the good item (lamp or lampholder).

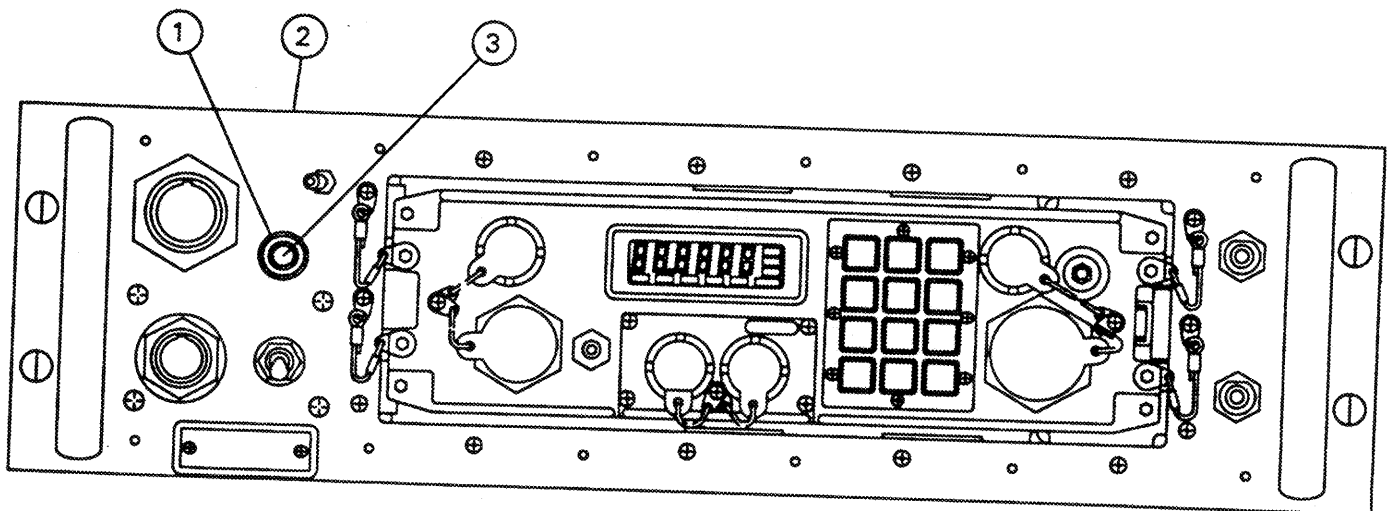

FRONT VIEW OF RT

REPLACE INCANDESCENT LAMP OR INDICATOR LENS LAMPHOLDER

- STEP 1. Position incandescent lamp ③ in indicator lens lampholder ①.
- STEP 2. Position and screw in indicator lens lampholder ① to lamp socket on RT front panel ②.
- STEP 3. Visually inspect incandescent lamp and indicator lens lampholder ① to insure proper installation.

2-15. REPLACEMENT OF THUMBSCREW

INITIAL SETUP

Material/Parts

Equipment Condition

Thumbscrews and Retainer Assembly
P/N A3028004-2

Power ON switch set to OFF.

NOTE

Use this procedure to replace any of the four thumbscrews, springs, or retaining split rings. The thumbscrew retainer may not be replaced at this maintenance level. Remove the new part from a new thumbscrew and retainer assembly and install it.

REMOVE THUMBSCREW

- STEP 1. Push thumbscrew ① in so that retaining split ring ② is accessible for removal.
- STEP 2. Using fingers, unscrew and remove retaining split ring ② that secures thumbscrew ① to the front panel ③.
- STEP 3. Remove thumbscrew ① and spring ④ from front panel ③.
- STEP 4. Inspect split ring ② and spring ④ for cracks, bends, breaks, or wear. Replace part if any defects are found.

REPLACE THUMBSCREW

- STEP 1. Position spring ④ onto thumbscrew ①.
- STEP 2. Position and install thumbscrew ① and spring ④ into front panel ③.
- STEP 3. Hold thumbscrew ① in and, using fingers, screw on retaining split ring ② to secure thumbscrew ① and spring ④ to the front panel ③.
- STEP 4. Visually inspect thumbscrew ① to insure proper installation.

2-15. REPLACEMENT OF THUMBSCREW (Cont.)

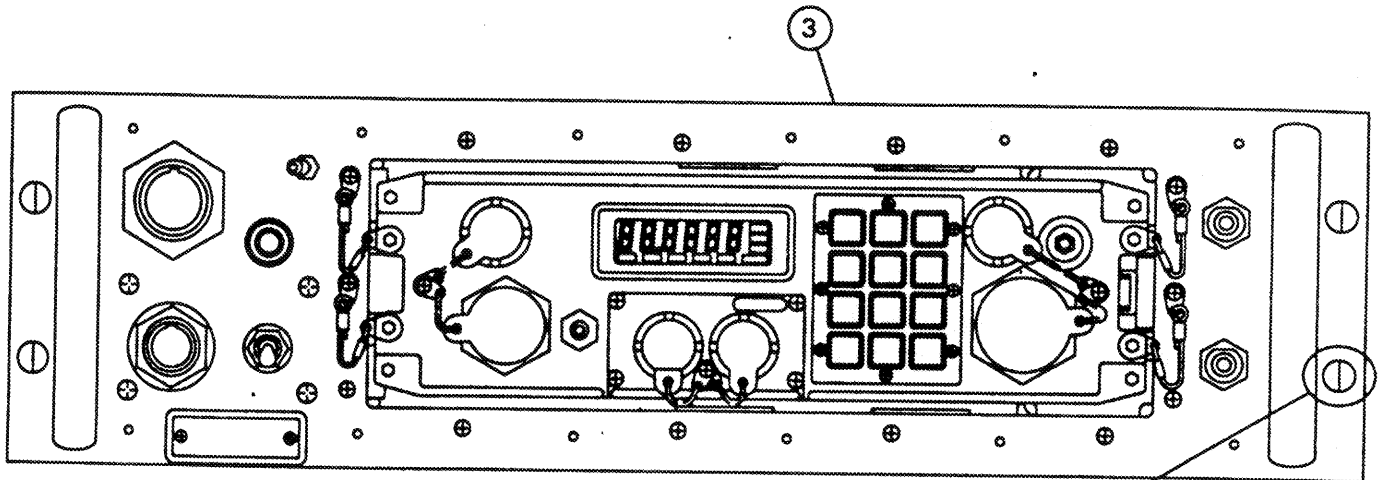

FRONT VIEW OF RT

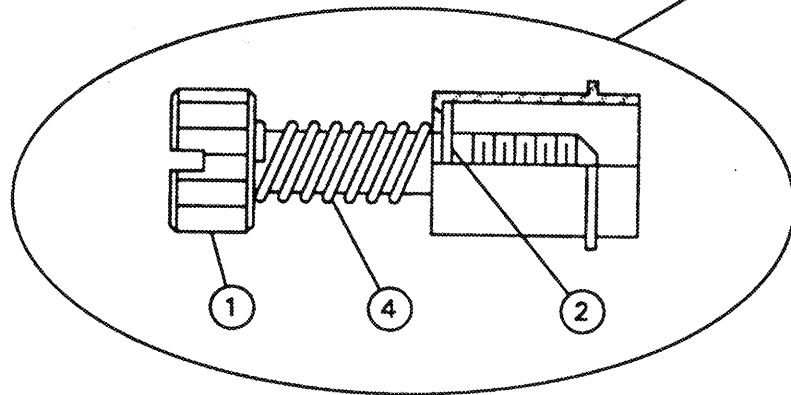

2-16. REPLACEMENT OF BOW HANDLE

INITIAL SETUP

Tools

Tool Kit TK-101/G

Material/Parts

Bow Handle, P/N MS39087-204AN

Equipment Condition

Power ON switch set to OFF.
Unit extended on slides.

NOTE

Use this procedure to replace either of the two bow handles. This procedure replaces one.

REMOVE BOW HANDLE

- STEP 1. Unscrew and remove 2 screws ①, lockwashers ②, and flatwashers ③, securing bow handle ④ to front panel ⑤.
- STEP 2. Inspect screws, lockwashers, and flatwashers, for cracks, bends, breaks, or stripped threads. Replace part if any if any defects are found.
- STEP 3. Remove defective bow handle ④ from front panel ⑤.

REPLACE BOW HANDLE

- STEP 1. Position bow handle ④ on front panel ⑤.
- STEP 2. Screw in and tighten 2 screws ①, lockwashers ②, and flatwashers ③ to secure bow handle ④ to front panel ⑤.
- STEP 3. Visually inspect bow handle ④ to ensure proper installation.

2-16. REPLACEMENT OF BOW HANDLE (Cont.)

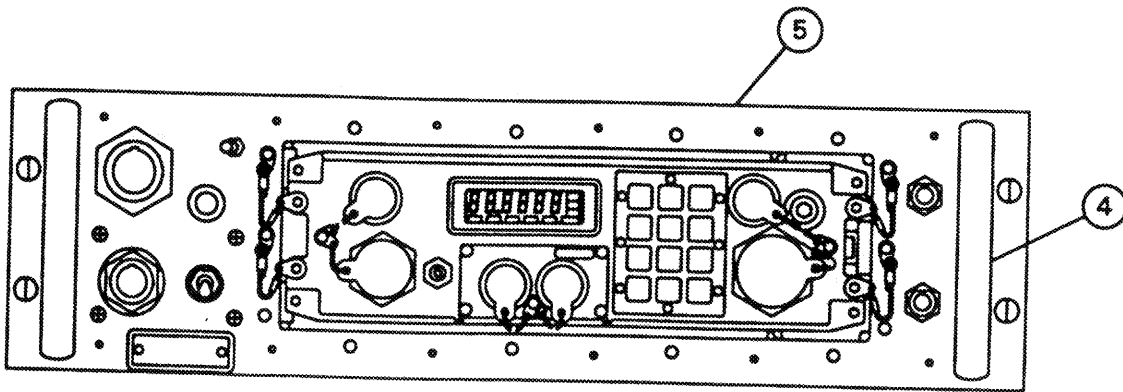

FRONT VIEW OF RT

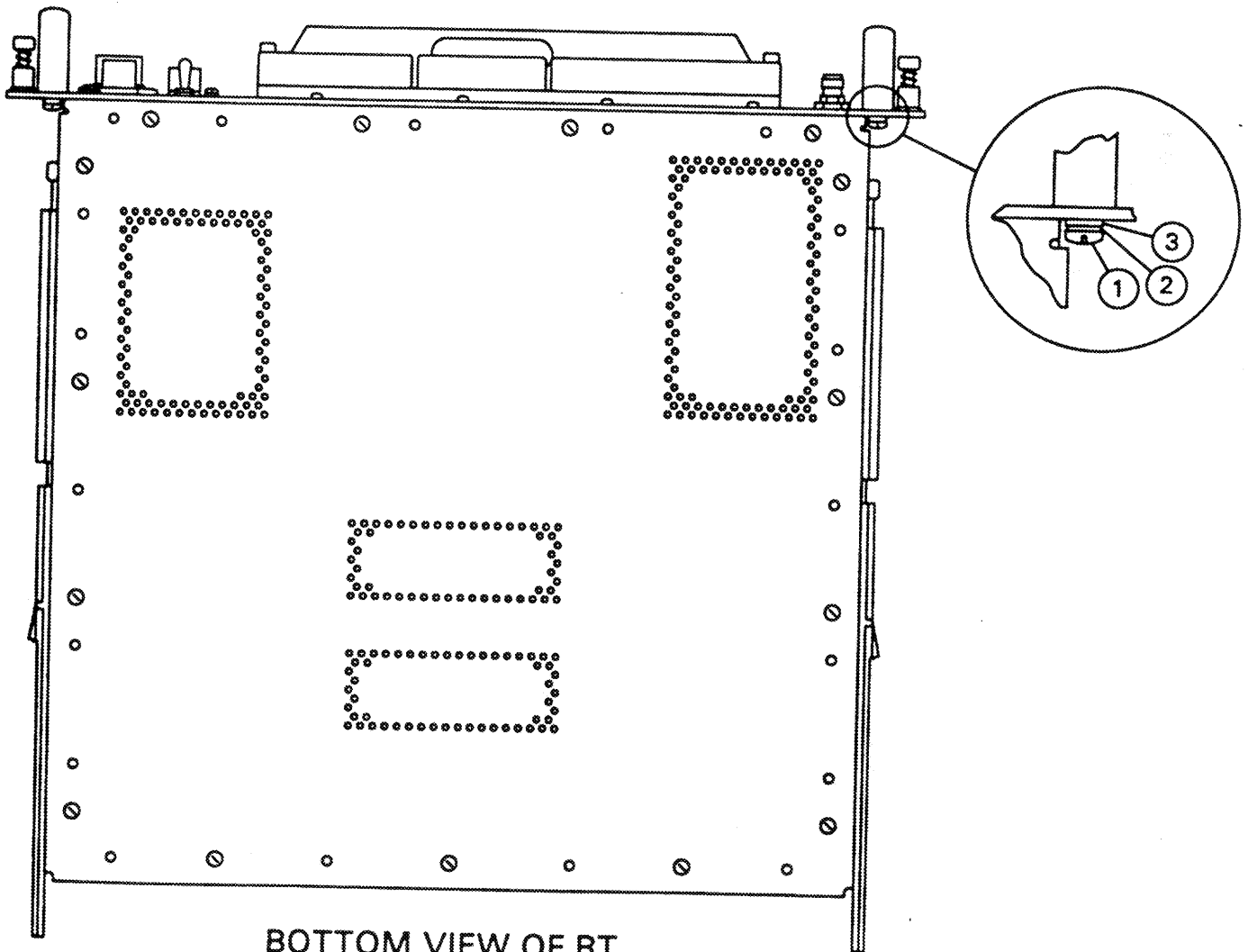

BOTTOM VIEW OF RT

2-17. REPLACEMENT OF LANYARD ASSEMBLY

INITIAL SET UP

Tools

Tool Kit TK-101/G

Material/Parts

Lanyard Assembly, P/N A3028687

Equipment Condition

Power ON switch set to OFF.

NOTE

Use this procedure to replace any of the four lanyard assemblies. This procedure replaces one.

REMOVE LANYARD ASSEMBLY

- STEP 1. Remove recessed socket head screw ① from front of ECCM module ②.
- STEP 2. Remove cross-tip screw ③ that secures lanyard assembly ④ to RT front panel ⑤.
- STEP 3. Remove cross-tip screw ③ from end of lanyard assembly ④. Retain hardware.
- STEP 4. Remove recessed socket head screw ① and lockwasher from end of lanyard assembly ④. Retain hardware.

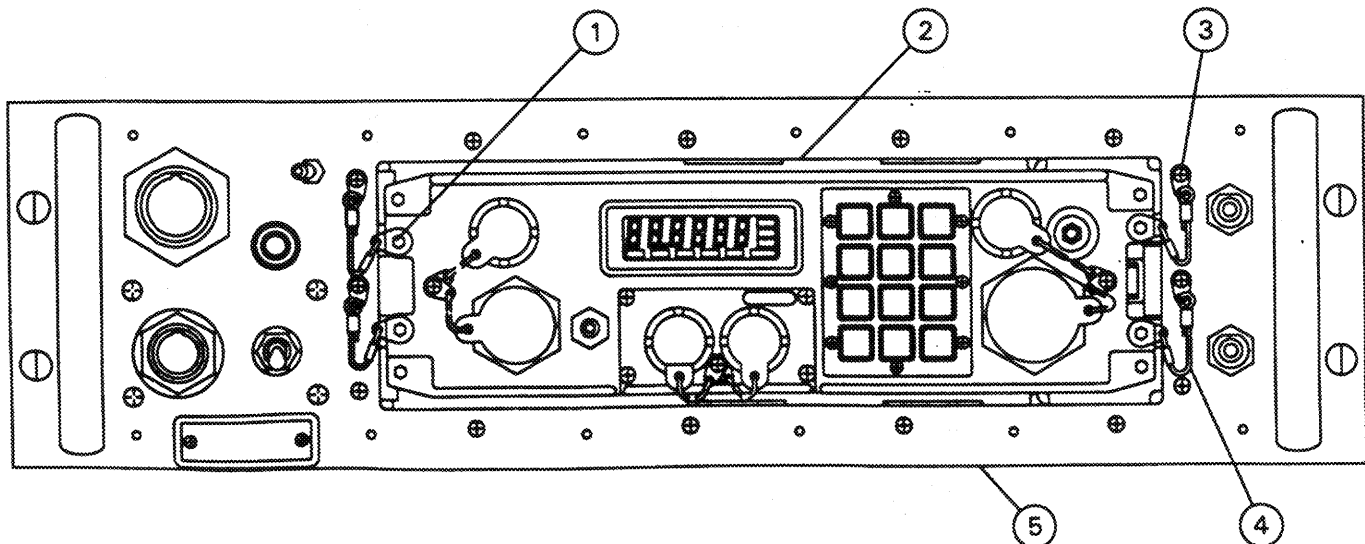

FRONT VIEW OF RT

2-17. REPLACEMENT OF LANYARD ASSEMBLY (Cont.)

REPLACE LANYARD ASSEMBLY

- STEP 1. Position lanyard assembly (4) on RT front panel (5), screw in and tighten cross-tip screw (3) securing lanyard assembly to RT.
- STEP 2. Install recessed socket head screw (1) and lockwasher on end of lanyard assembly (4).
- STEP 3. Position and screw in recessed socket head screw (1), securing lanyard assembly (4) to front of ECCM module (2).
- STEP 4. Visually inspect lanyard assembly (4) to insure proper installation.

Section VI. PREPARATION FOR STORAGE OR SHIPMENT

2-18. GENERAL

- a. Army. Refer to paragraph 1-6a for administrative storage.
- b. Navy. Refer to NAVSUP PUB 503.
- c. Air Force. Refer to AFM 66-267 (storage) and AFR 67-31 (shipment).

2-19. MARKING

The marking on the exterior of the container shall be in accordance with MIL-STD-129H.

CHAPTER 3 INTERMEDIATE DIRECT SUPPORT AND GENERAL SUPPORT MAINTENANCE

NOTE

Intermediate Direct Support Maintenance is not allocated for the RT.

<u>Subject</u>	<u>Page</u>
Intermediate General Support Maintenance	3-79
Intermediate General Support Troubleshooting	3-2
Repair Parts, Special Tools; Test, Measurements, and Diagnostic Equipment (TMDE); and Support Equipment	3-1

Section I. REPAIR PARTS; SPECIAL TOOLS; TEST, MEASUREMENTS, AND DIAGNOSTIC EQUIPMENT (TMDE); AND SUPPORT EQUIPMENT

3-1. COMMON TOOLS AND EQUIPMENT

a. Army. For authorized common tools and equipment, refer to the Modified Table of Organization and Equipment (MTOE) applicable to your unit.

b. Navy. Navy personnel refer to applicable Tables of Allowance (TA).

c. Air Force. Air Force personnel refer to applicable Tables of Allowance (TA).

3-2. SPECIAL TOOLS, TMDE, AND SUPPORT EQUIPMENT

Special tools, TMDE, and support equipment and their purposes are listed in the Maintenance Allocation Chart, Appendix B.

3-3. REPAIR PARTS

Repair parts used during Intermediate General Support Maintenance are listed and illustrated in the repair parts and special tools list located in TM 11-5895-1303-24P (Navy) EE162-NG-PLD-010/W110-RT1512G (Air Force) TO 31R2-4-562-4.

Section II. INTERMEDIATE GENERAL SUPPORT TROUBLESHOOTING

3-4. GENERAL

a. The following troubleshooting procedures will help technicians at the Intermediate General Support Maintenance level to isolate faults to the defective board/module and, in some cases, to a piece part.

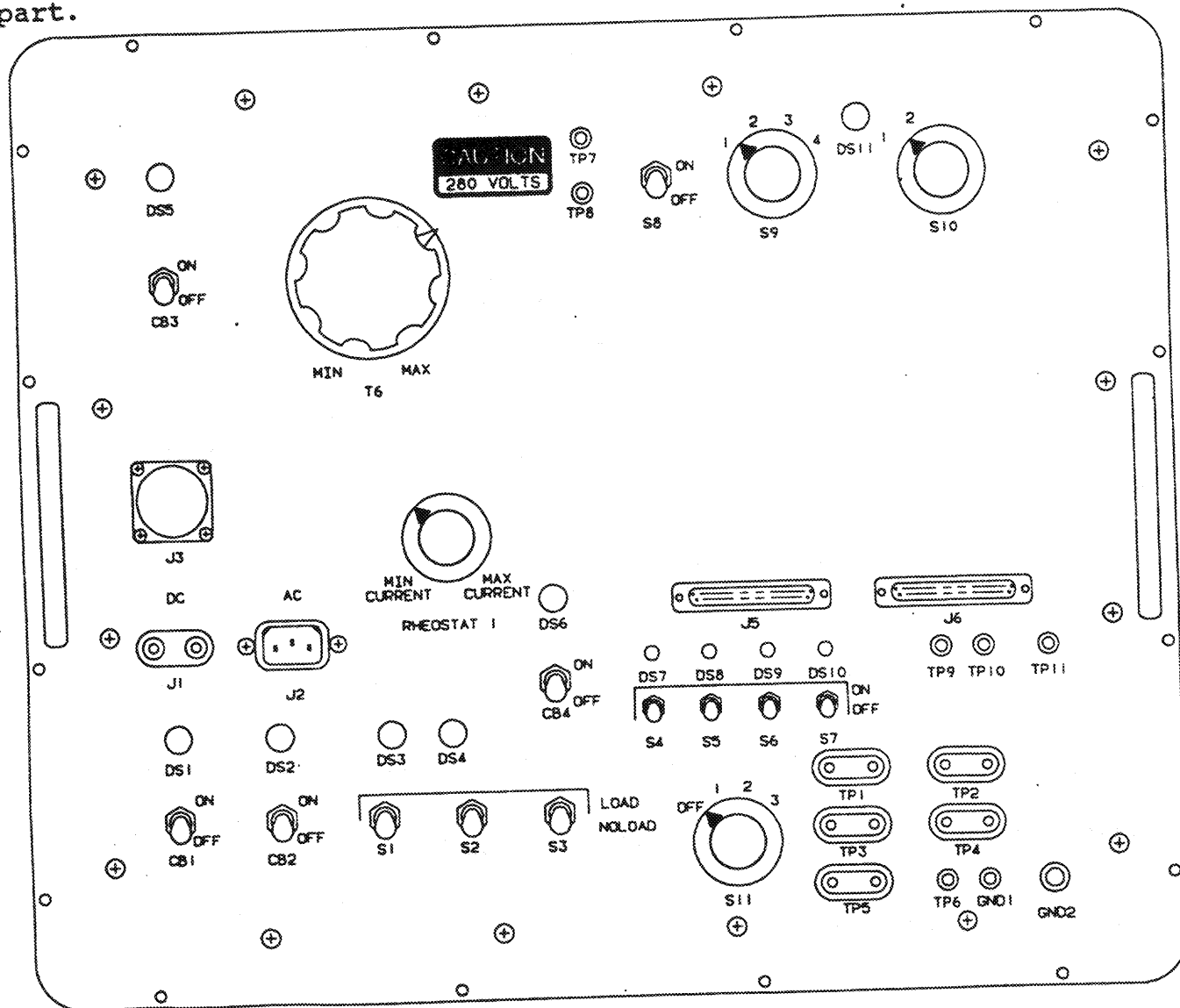

TEST SET, POWER SUPPLY TS-4243/G

b. Test Set, Power Supply. This test fixture provides the necessary loads, interface and test points necessary to test various Regency Net power supplies. It also includes an assortment of cable assemblies including W1, W3, and W38.

3-5. PRELIMINARY TROUBLESHOOTING PROCEDURES

NOTE

Repair of ECCM is authorized for the Special Repair Activity (SRA) only.

A preliminary troubleshooting test consists of connecting power to the RT and running BIT. BIT will indicate which assembly/module is defective. The following test is performed -

- Upon receiving a suspected defective RT.
- Following troubleshooting of a RT.
- After completing repair action on a RT.

BUILT-IN TEST (BIT)

- STEP 1. Connect the power cable, CX-13361/G, to the RT.
- STEP 2. Connect other end of power cable to 115 Vac outlet.
- STEP 3. Set RT power ON switch to ON. Off-Line BIT is initiated when power is applied.
- STEP 4. If the ECCM display shows FAILED, an error has occurred. Press the ENT/TST key to display the fault code. See BIT Fault Table for fault codes and the applicable replacement procedure.
- STEP 5. See the Maintenance Allocation Chart to determine the repair activity to which the defective assembly must be referred.
- STEP 6. Press ENT/TST key to show subsequent faults, correct as required. Repeat until first fault number reappears on display. Normal operation is restored using the 7/CLR key.
- STEP 7. Press the 2ND/# key and then the END/TST key (in local mode only) to repeat Off-Line BIT. If RT still fails BIT, refer to paragraph 3-9.
- STEP 8. Set RT power ON switch to OFF.
- STEP 9. Remove Power Cable from 115 Vac outlet and from RT.

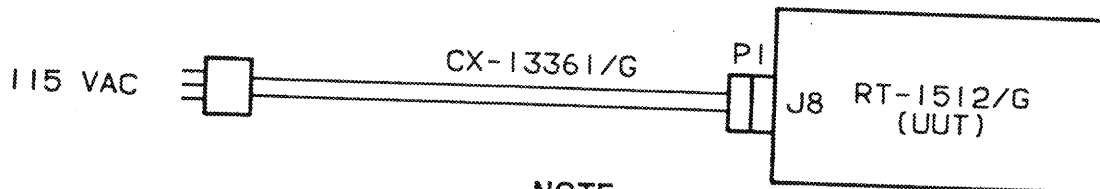

NOTE

The fault codes are used for different systems and also for levels of maintenance not covered in this manual. In these cases, the corrective action is "NA" (Not Applicable). Corrective action is listed only for maintenance actions covered in this manual.

3-5. PRELIMINARY TROUBLESHOOTING PROCEDURES (Cont.)

BIT FAULT TABLE

Fault code	Corrective action
01 thru 19	NA
20 thru 32	Replace ECCM module (para. 2-13)
33 thru 39	NA
40 thru 43	Replace ECCM module (para. 2-13)
44 thru 49	NA
50	Replace Reference Oscillator (para. 3-24); if replacement of Reference Oscillator fails to correct problem, replace ECCM module para. 2-13.
51	Replace Frequency Synthesizer (para. 3-23)
52 thru 58	NA
59	Replace ECCM module (para. 2-13); if replacement of ECCM module fails to correct problem, replace Reference Oscillator (para. 3-24).
60	Replace Power Supply (para. 3-31)
61	Replace Reference Oscillator (para. 3-24)
62	Replace Audio Sideband Exciter (para. 3-25)
63	Replace RF Amplifier Exciter (para. 3-26)
64	Replace RF Switch (para. 3-27)
65	Replace RF Receiver (para. 3-28)
66	Replace IF Receiver (para. 3-29)
67	Replace Audio Receiver (para. 3-30)
68 thru 79	NA

3-6. TROUBLESHOOTING PROCEDURE

Troubleshooting procedures contained in the troubleshooting flow charts are intended as an aid to technicians working at the Intermediate General Support maintenance level. In view of the complexity of the equipment, these flow charts can not cover all possible failures and faults which may occur. Flow charts serve as a guide to logical step-by-step troubleshooting. Wiring diagrams of the RT are contained in the back of this manual. These should be referred to for location of connections and test points used during troubleshooting. Test point locations are illustrated in figures FO-8 and FO-9 as TP numbers, that is, 1 on the flow chart refers to TP1 on the FO, 5 on the flow chart refers to TP5 on the FO, etc. A symptom index is provided to help you determine the flow chart or procedure applicable to the type of failure.

SYMPTOM INDEX

SYMPTOM	PARAGRAPH
RT Fails BIT	3-5
RT Will Not Turn On (Energize)	3-8
RT Fails BIT After Module Replacement	3-9
Power Supply Failure	3-10

3-7. FLOW CHARTS AND HOW TO USE THEM

Flow Charts make troubleshooting easier and give maintenance personnel a clear path to follow.

To use the Flow Chart begin at START and follow the path indicated by the arrow. Perform the task given in the symbol block and then follow the arrow to the next block. At the decision symbol be sure to follow the correct path indicated by YES or NO.

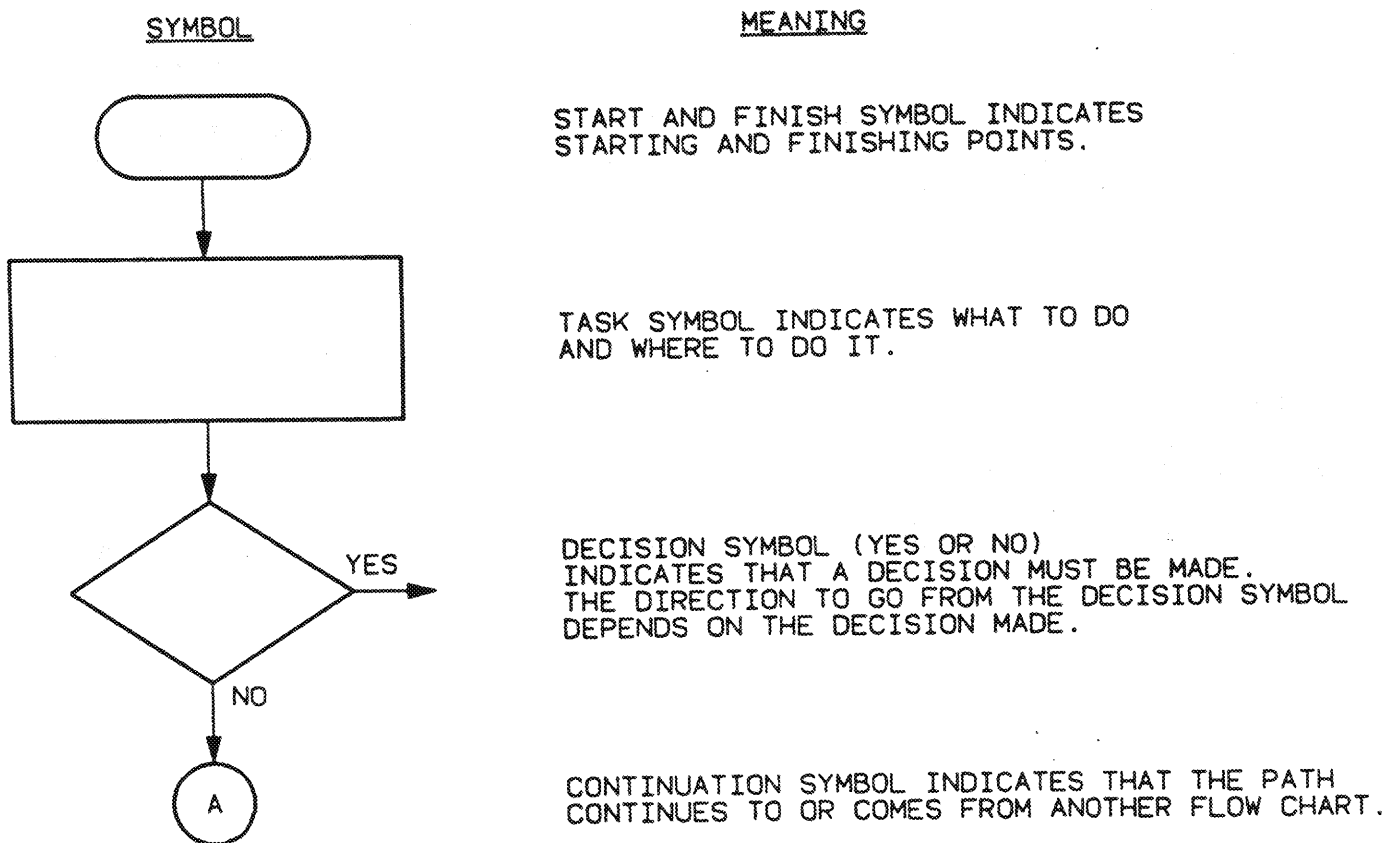

3-8. RT WILL NOT ENERGIZE

When the RT does not turn on, power light does not light, and the ECCM keyboard does not light, perform the following troubleshooting procedure. See figures FO-1, FO-7 for RT chassis test points called out in the flow charts.

INITIAL SETUP

Test Equipment

Digital Multimeter AN/USM-486
Power Cable, CX-13361/G

Tools

Tool Kit TK-17
Workstation, Static

Equipment Condition

RT BIT performed (para. 3-5)
RT connected to power
RT covers removed (para. 3-12)

WARNING

HIGH VOLTAGE is used in the operation of this equipment. DEATH ON CONTACT may result if personnel fail to observe safety precautions. Be careful not to contact high-voltage connections when troubleshooting.

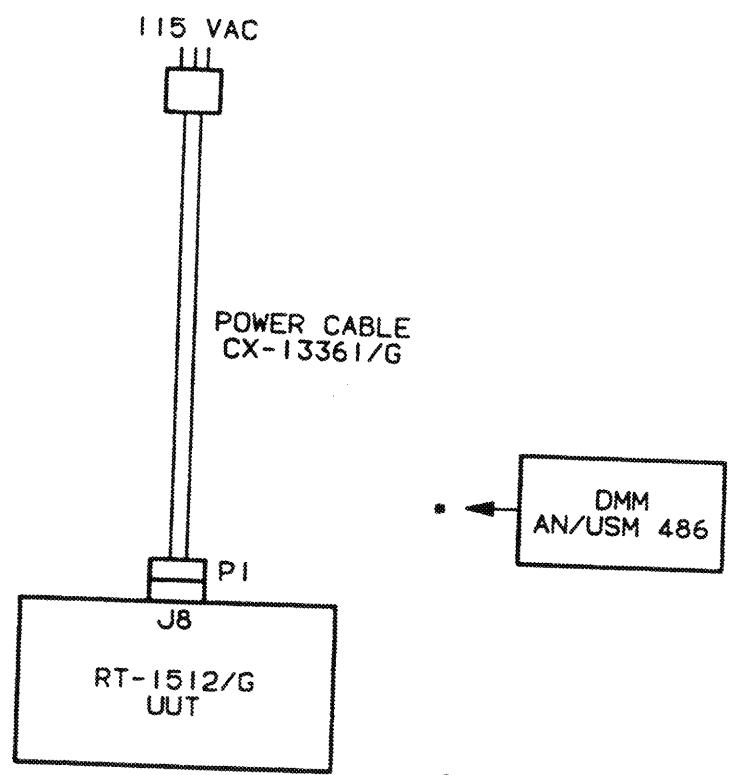

* CONNECT AS DIRECTED

3-8. RT WILL NOT ENERGIZE (Cont.)

NOTE: THE NUMBER WITHIN THIS SYMBOL ○ REFERS TO THE LOCATION ON FO-7 AT WHICH THIS TEST OR ACTION IS PERFORMED.

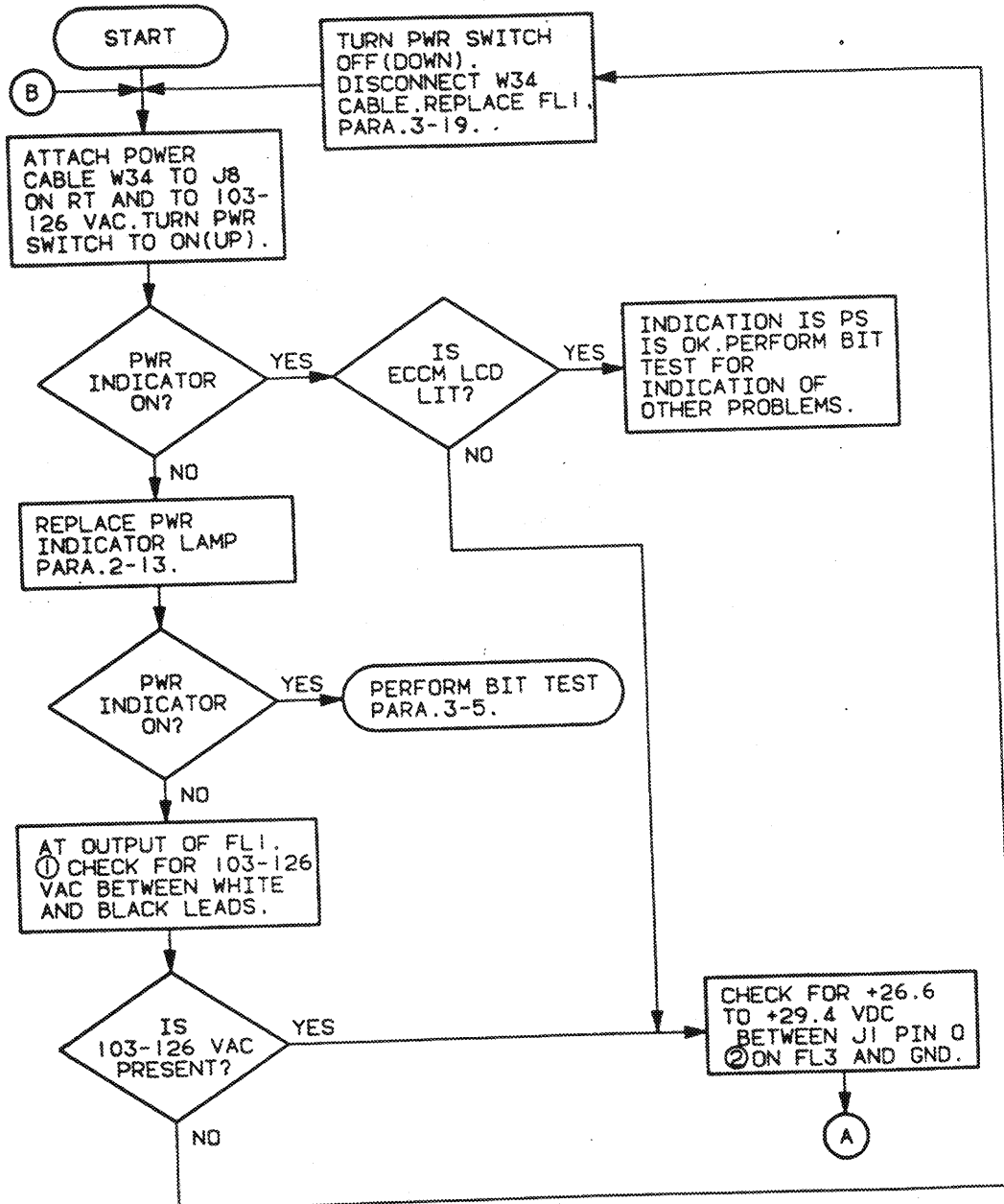

3-8. RT WILL NOT ENERGIZE (Cont.)

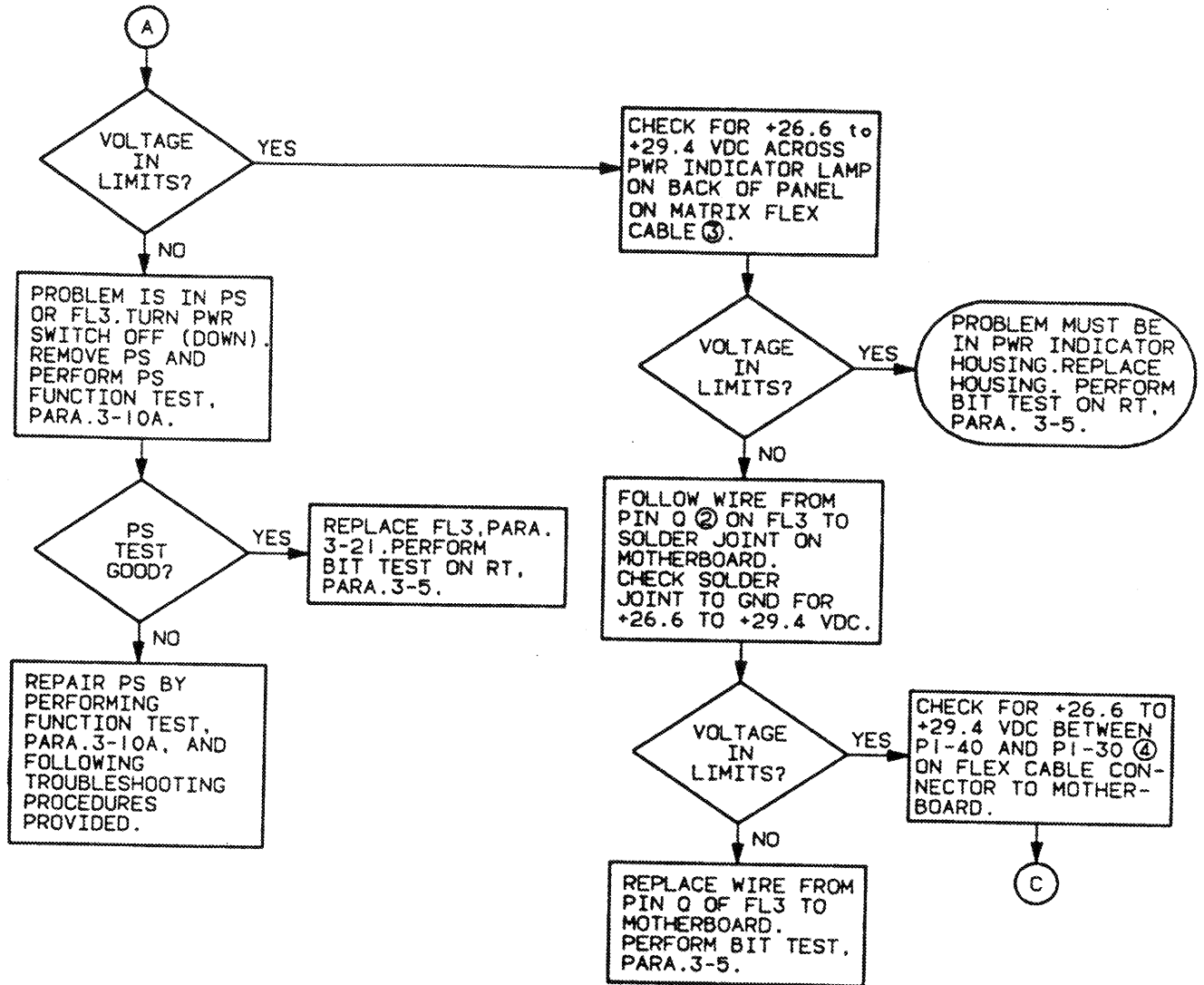

3-8. RT WILL NOT ENERGIZE (Cont.)

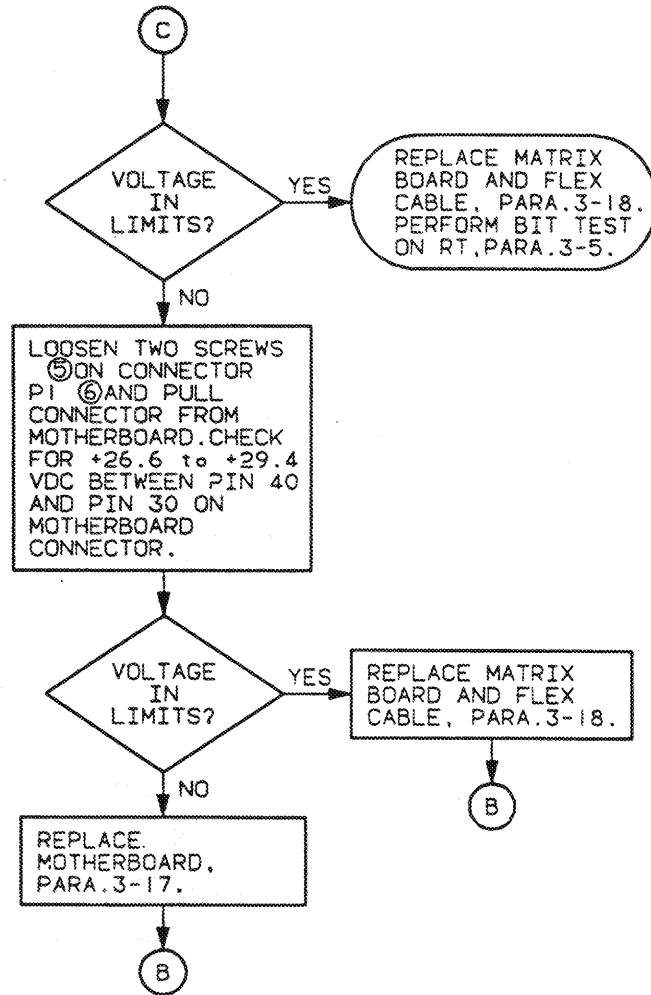

3-9. CHASSIS COMPONENT DEFECTIVE

When the RT fails BIT after replacing the indicated faulty module, the problem is likely a faulty chassis component. Perform the following troubleshooting procedure.

INITIAL SETUP

Test Equipment

Digital Multimeter AN/USM-486
Power Cable, CX-13361/G

Equipment Condition

RT covers removed (para. 3-12)
RT connected to power and BIT performed (para. 3-5)

Tools

Tool Kit TK-17
Workstation, Static

WARNING

HIGH VOLTAGE is used in the operation of this equipment. DEATH ON CONTACT may result if personnel fail to observe safety precautions. Be careful not to contact high-voltage connections when troubleshooting.

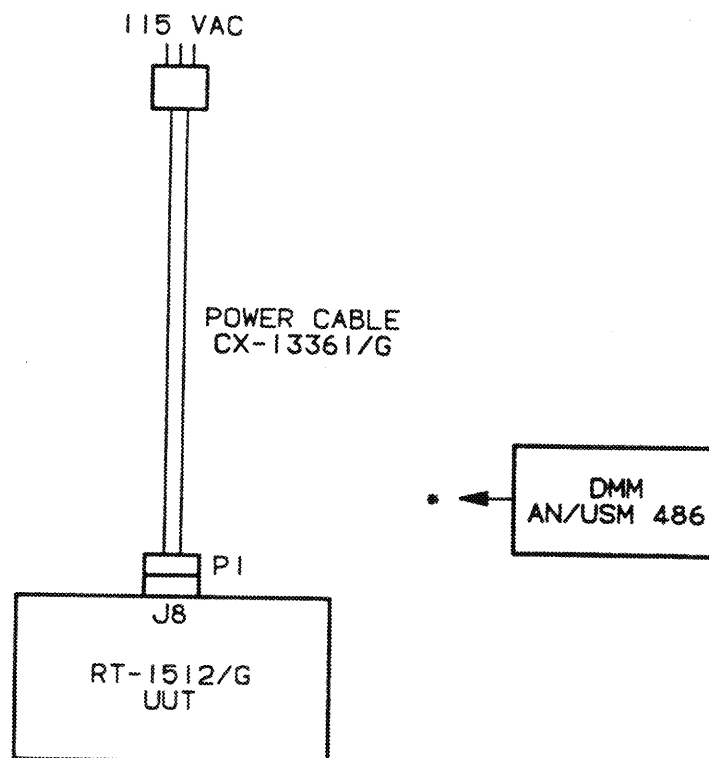

* CONNECT AS DIRECTED

3-9. CHASSIS COMPONENT DEFECTIVE (Cont.)

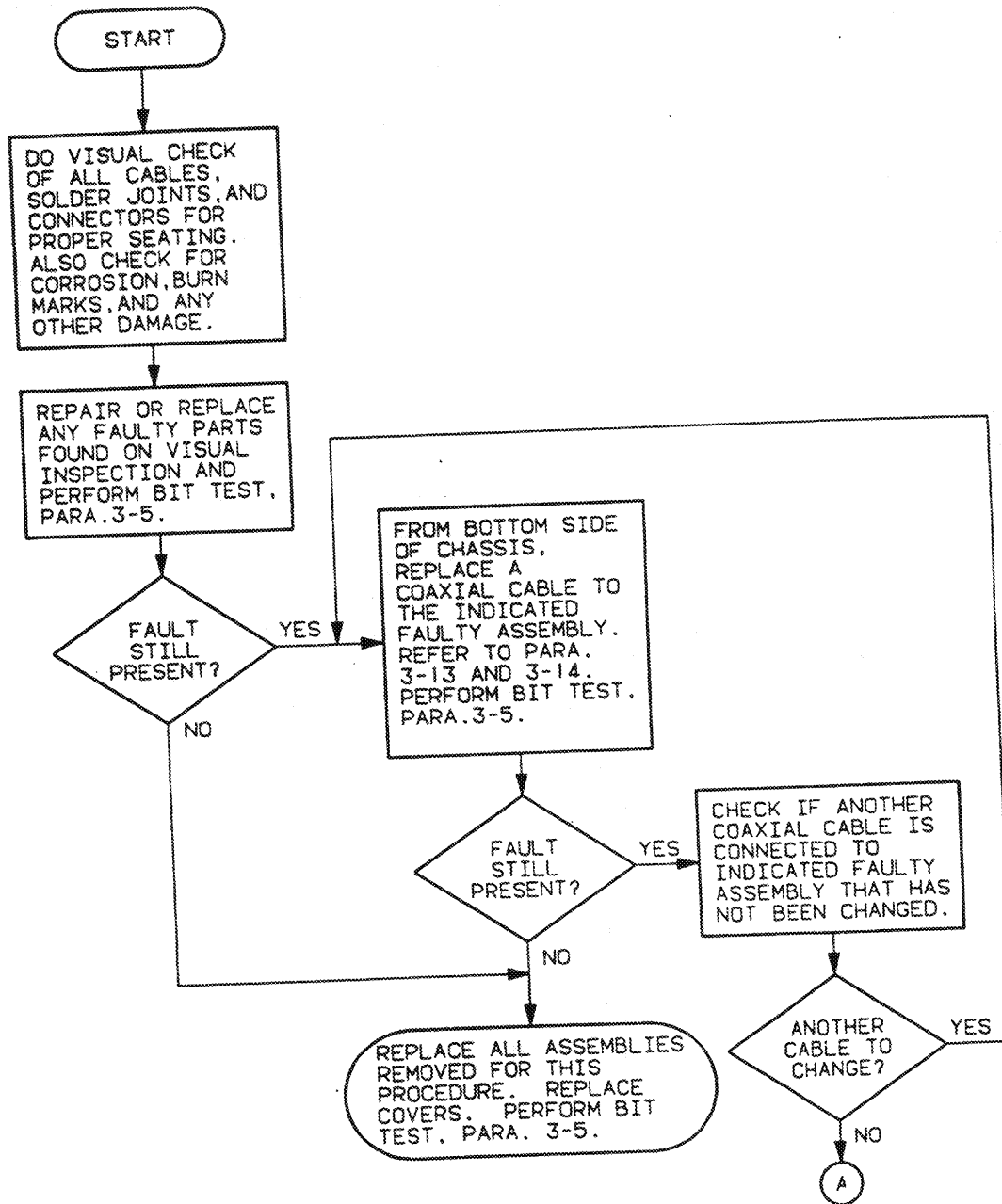

3-9. CHASSIS COMPONENT DEFECTIVE (Cont.)

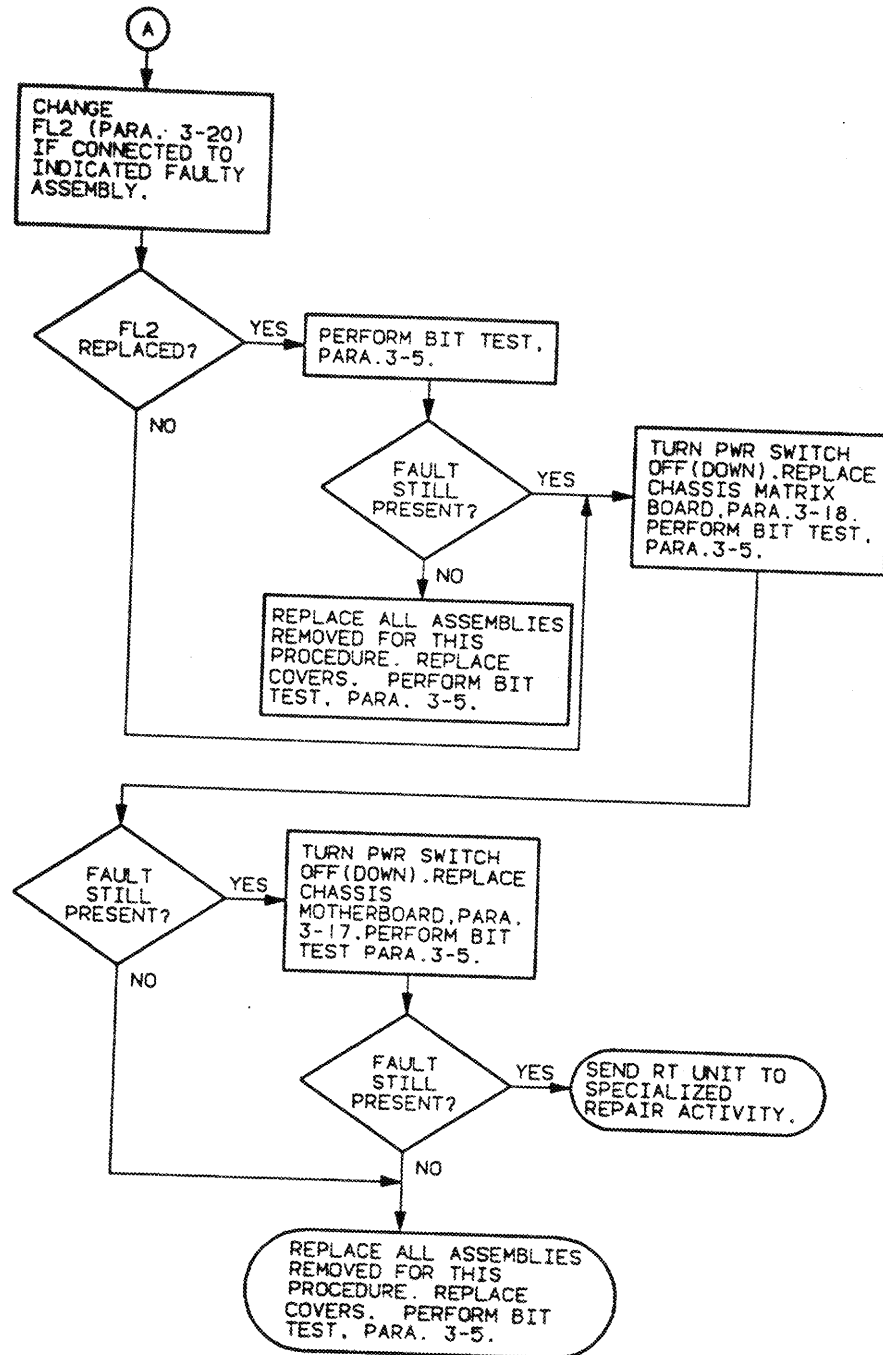

3-10. POWER SUPPLY TROUBLESHOOTING

Troubleshooting of the power supply is divided into five items of the troubleshooting procedures. They are:

- The operational test of the power supply.
- The resistance check of the various voltage supply outputs.
- Troubleshooting current limiting circuits.
- Current limiting resistor selection.
- Troubleshooting of the complete power supply.

a. Power Supply Functional Test. The power supply assembly functional test consists of a NO LOAD test, a LOAD and OVERLOAD test. If the power supply fails to pass a test, a power supply symptom index is provided at the end of the functional test.

The power supply function test is to be performed when -

- Checking of a power supply as a possible defective unit.
- Following troubleshooting of a RT during which removal of a power supply has occurred.
- After completing repair action on a power supply.

INITIAL SETUP

Test Equipment

Test Set, Power Supply TS-4244/G
 Digital Multimeter AN/USM-486
 Oscilloscope AN/USM-488
 Active Load, EL 750B
 Current Shunt, Fluke 80J-10
 DC Power Supply, PP-8202/G

Equipment Condition

RT BIT completed (para. 3-5)
 PS assy removed (para. 3-31)

Tools

Tool Kit, TK-17
 Workstation, Static

WARNING

HIGH VOLTAGE is used in the operation of this equipment. DEATH ON CONTACT may result if personnel fail to observe safety precautions. Be careful not to contact high-voltage connections when testing this equipment.

3-10. POWER SUPPLY TROUBLESHOOTING (Cont.)

CAUTION

This equipment contains components that are sensitive to damage by ESD. Improper handling will result in component and assembly failure. Use extreme caution when handling. Refer to DOD-HDBK-263 for proper handling procedures.

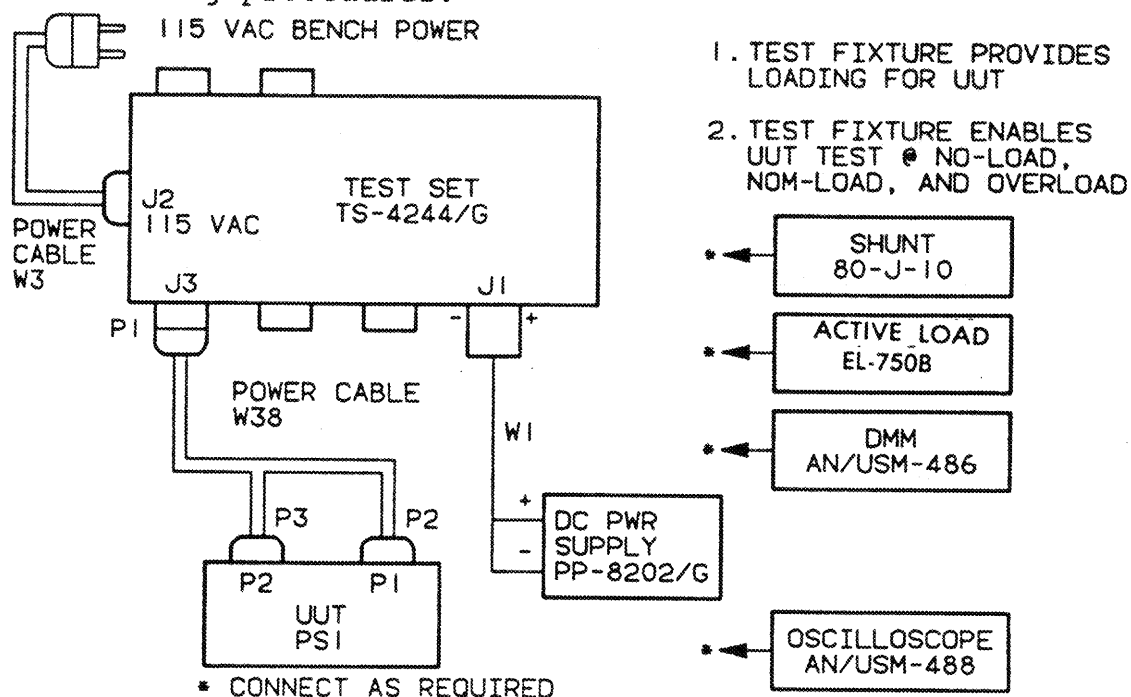

TEST FIXTURE SETUP

- STEP 1. Make sure that all switches and circuit breakers (CB) are in the OFF position. RHEOSTAT 1 to MIN.
- STEP 2. Connect cable W38 to connector J3 on power supply test fixture and to connectors on unit under test (UUT), the power supply.
- STEP 3. Connect cable W3 to connector J2 on the power supply test fixture and to 115 Vac.
- STEP 4. Connect cable W1 to connector J1 on the PS test fixture and to the PP-8202/G (DC PS). Turn on, and adjust DC PS for +28 volts.
- STEP 5. Set CB1 to ON (AC power) and observe that DS1 lights.
- STEP 6. Set CB2 to ON (DC power) and observe that DS2 lights.

3-10. POWER SUPPLY TROUBLESHOOTING (Cont.)

NOTE

BIT indicator DS3 lit, on test fixture, indicates no fault. Shorting bars are in TP1 thru TP5.

(1) NO-LOAD VOLTAGE MEASUREMENTS

- STEP 7. Turn on DMM and set to measure Vdc.
- STEP 8. Measure the voltage between TP1 and GND1. The meter should indicate between +11.4 and +12.6 Vdc.
- STEP 9. Measure the voltage between TP2 and GND1. The meter should indicate between +26.6 and +29.4 Vdc.
- STEP 10. Measure the voltage between TP3 and GND1. The meter should indicate between +4.75 and +5.25 Vdc.
- STEP 11. Measure the voltage between TP4 and GND1. The meter should indicate between -11.4 and -12.6 Vdc.
- STEP 12. Measure the voltage between TP5 and GND1. The meter should indicate between +7.88 and +8.72 Vdc.
- STEP 13. Set CB1 and CB2 to OFF. Disconnect DMM.

(2) +12 Vdc LOAD AND OVERLOAD VOLTAGE AND CURRENT MEASUREMENTS

- STEP 14. Set S1 to the LOAD position.
- STEP 15. Set CB1 and CB2 to ON.
- STEP 16. With the DMM, measure the voltage between TP1 and GND1. Voltage should be +11.4 to +12.6 Vdc.
- STEP 17. Connect oscilloscope probe between TP1 and GND1. Observe ripple voltage of 0.12 Volt Peak-to-Peak (Vp-p) maximum. (Ignore spikes of less than 2 microseconds duration.)
- STEP 18. Set CB1 and CB2 to OFF.
- STEP 19. Remove shorting bar from TP1. Connect DMM in series between red and black jacks. Set DMM to measure 2,000 milliamperes (mA) current.

3-10. POWER SUPPLY TROUBLESHOOTING (Cont.)

NOTE

In the following step, if the DMM is not connected to TP1 prior to setting the circuit breakers to ON, the power supply will not be loaded and correct action of CB2 and DS3 will not be seen.

- STEP 20. Set CB1 and CB2 to ON.
 - STEP 21. DMM should indicate between 360 and 440 milliamps.
 - STEP 22. Set CB1 and CB2 to OFF, set S11 to 1, and set CB1 and CB2 to ON.
 - STEP 23. Slowly turn RHEOSTAT 1 towards MAX until BIT lamp DS3 goes off. Maximum current indication before lamp DS3 goes off should not be more than 1,200 mA.
 - STEP 24. Slowly turn RHEOSTAT 1 toward MIN until BIT lamp DS3 lights again. Current indication when lamp DS3 lights again should not be less than 800 mA.
 - STEP 25. Set CB1 and CB2 to OFF.
 - STEP 26. Disconnect DMM and set S11 to OFF.
 - STEP 27. Replace shorting bar in TP1. Set RHEOSTAT 1 to MIN.
- (3) +28 Vdc LOAD AND OVERLOAD VOLTAGE AND CURRENT MEASUREMENTS
- STEP 28. Set CB1 and CB2 to ON.
 - STEP 29. Set DMM to measure 200 Vdc. Measure between TP2 and GND1. Voltage should be +26.6 to +29.4 Vdc.
 - STEP 30. Connect oscilloscope probe between TP2 and GND1. Observe ripple voltage of 0.28 Vp-p maximum. (Ignore spikes of less than 2 microseconds duration.)
 - STEP 31. Set CB1 and CB2 to OFF.
 - STEP 32. Remove shorting bar from TP2. Connect DMM in series between red and black jacks. Set DMM to measure 2,000 mA current.
 - STEP 33. Set CB1 and CB2 to ON.
 - STEP 34. DMM should indicate between 1.08 and 1.32 amps.
 - STEP 35. Set CB1 and CB2 to OFF, set S11 to 2, set CB1 and CB2 to ON.

3-10. POWER SUPPLY TROUBLESHOOTING (Cont.)

- STEP 36. Slowly turn RHEOSTAT 1 towards MAX until BIT lamp DS3 goes off. Maximum current indication before lamp DS3 goes off should not be more than 1.68 amps.
- STEP 37. Slowly turn RHEOSTAT 1 towards MIN until BIT lamp DS3 lights again. Current indication when lamp DS3 lights again should not be less than 1.32 amps.
- STEP 38. Set CB1 and CB2 to OFF.
- STEP 39. Disconnect DMM and set S11 to OFF.
- STEP 40. Replace shorting bar in TP2. Set RHEOSTAT 1 to MIN.

(4) +5 Vdc LOAD AND CURRENT MEASUREMENTS

- STEP 41. Set CB1 and CB2 to ON.
- STEP 42. Set DMM to measure +5 Vdc.
- STEP 43. Measure the voltage between TP3 and GND1. Meter should indicate +4.75 to +5.25 Vdc.
- STEP 44. Connect oscilloscope probe between TP3 and GND1 and observe ripple voltage of 0.05 Vp-p maximum. (Ignore spikes of less than 2 microseconds duration.)
- STEP 45. Set CB1 and CB2 to OFF.
- STEP 46. Remove shorting bar from TP3. Connect DMM in series between red and black jacks of TP3. Set DMM to measure 2,000 mA current.
- STEP 47. Set CB1 and CB2 to ON.
- STEP 48. DMM should indicate between 450 and 550 milliamps.
- STEP 49. Set CB1 and CB2 to OFF.
- STEP 50. Replace shorting bar in TP3.

(5) -12 Vdc LOAD AND OVERLOAD VOLTAGE AND CURRENT MEASUREMENTS

- STEP 51. Set CB1 and CB2 to ON.
- STEP 52. Set DMM to measure 20 Vdc. Measure between TP4 and GND1. Voltage should be -11.4 to -12.6 Vdc.

3-10. POWER SUPPLY TROUBLESHOOTING (Cont.)

- STEP 53. Connect oscilloscope probe between TP4 and GND1 and observe ripple voltage of 0.12 Vp-p maximum. (Ignore spikes of less than 2 microseconds duration.)
- STEP 54. Set CB1 and CB2 to OFF.
- STEP 55. Remove shorting bar from TP4. Connect DMM in series between red and black jacks. Set DMM to measure 2,000 mA current.
- STEP 56. Set CB1 and CB2 to ON.
- STEP 57. DMM should indicate between 180 and 220 milliamps.
- STEP 58. Set CB1 and CB2 to OFF.
- STEP 59. Set S11 to the 3 position.
- STEP 60. Set CB1 and CB2 to ON.
- STEP 61. Slowly turn RHEOSTAT 1 towards MAX until BIT lamp DS3 goes off. Maximum current indication before lamp DS3 goes off should not be more than 600 mA.
- STEP 62. Slowly turn RHEOSTAT 1 towards MIN until BIT lamp DS3 lights again. Current indication when lamp DS3 lights again should not be less than 400 mA.
- STEP 63. Set CB1 and CB2 to OFF.
- STEP 64. Disconnect DMM and set S11 to OFF.
- STEP 65. Replace shorting bar in TP4. Set RHEOSTAT 1 to MIN.
- (6) +8.3 Vdc LOAD AND OVERLOAD VOLTAGE AND CURRENT MEASUREMENTS
- STEP 66. Set CB1 and CB2 to ON.
- STEP 67. Set DMM to measure 20 Vdc. Measure between TP5 and GND1. Voltage should be +7.88 to +8.72 Vdc.
- STEP 68. Connect oscilloscope probe between TP5 and GND1 and observe ripple voltage of 0.08 Vp-p maximum. (Ignore spikes of less than 2 microseconds duration.)
- STEP 69. Set CB1 and CB2 to OFF.
- STEP 70. Remove shorting bar from TP5. Insert current shunt 80J-10 into TP5 (observe polarity).

3-10. POWER SUPPLY TROUBLESHOOTING (Cont.)

- STEP 71. Set DMM to measure 200 mVdc. Connect DMM to current shunt (observe polarity).
- STEP 72. Set CB1 and CB2 to ON.
- STEP 73. DMM should indicate between 0.0217 and 0.0253 Vdc (21.7 to 25.3 mVdc).
- STEP 74. Set CB1 and CB2 to OFF.
- STEP 75. Remove current shunt and disconnect DMM.
- STEP 76. Insert current shunt into DMM (observe polarity). Connect positive terminal of Active Load to TP5 red jack. Connect negative terminal of Active Load to red jack of current shunt. Connect black jack of current shunt to GND2.
- STEP 77. Set Active Load switches as follows:
- VOLTS - 47
 - MODE - R (in)
 - DYNAMIC LOADING - OFF (in)
 - Meter CURRENT RANGE - 10A (in)
 - DYNAMIC CURRENT - Counter-clockwise CCW
 - STATIC CURRENT - Counter-clockwise) CCW
 - PWR - ON (in)
 - LOAD - ON (up)
- STEP 78. Remove shorting bar from TP3.
- STEP 79. Set CB1 and CB2 to ON.
- STEP 80. Slowly turn STATIC CURRENT knob CW until BIT lamp DS3 goes off. Maximum voltage indication (on DMM) before lamp DS3 goes off should not be more than 43.0 mVdc. Do not exceed 43.0 mVdc on the DMM.
- STEP 81. Slowly turn STATIC CURRENT knob CCW until BIT lamp DS3 lights again. Voltage indication when lamp DS3 lights again should not be less than 35.0 mVdc.
- STEP 82. On electronic load set STATIC CURRENT fully CCW and LOAD switch to OFF. Set CB1 and CB2 to OFF.
- STEP 83. Disconnect DMM, Active Load, and current shunt.
- STEP 84. Replace shorting bar in TP3 and TP5.

3-10. POWER SUPPLY TROUBLESHOOTING (Cont.)

POWER SUPPLY SYMPTOM INDEX

SYMPTOM	Paragraph
Fails +12 V NO-LOAD or LOAD TEST	3-10b
Fails +28 V NO-LOAD or LOAD TEST	3-10c
Fails +5 V NO-LOAD or LOAD TEST	3-10d
Fails -12 V NO-LOAD or LOAD TEST	3-10e
Fails +8.3 V NO-LOAD or LOAD TEST	3-10f
Fails +12 V Current Limiting Test	3-10g
Fails +28 V Current Limiting Test	3-10h
Fails -12 V Current Limiting Test	3-10i
Fails +8.3 V Current Limiting Test	3-10j
Power Transformer Current Limiting Failure	3-10k
No Voltage Output	3-10r

3-10. POWER SUPPLY TROUBLESHOOTING (Cont.)

b. Troubleshooting +12 V Power Supply Output Circuit. This troubleshooting procedure is to be performed for failure of the NO-LOAD or LOAD Functional test. For Test Point (TP) callouts on troubleshooting flow charts refer to figures FO-5, FO-8, and FO-9.

INITIAL SETUP

Test Equipment

Digital Multimeter AN/USM-486
Test Set, Power Supply TS-4244/G
Oscilloscope AN/USM-488
DC Power Supply, PP-8202/G

Equipment Condition

PS1 functional test completed
(para. 3-10)
Test fixture CB1 and CB2 OFF.
PS regulator output CCA removed
(para. 3-33) but reconnected
to ac to dc inverter

Tools

Tool Kit TK-17
Workstation, Static

WARNING

VOLTAGE is used in the operation of this equipment. DEATH ON CONTACT may result if personnel fail to observe safety precautions. Be careful not to contact high-voltage connections when testing this equipment.

CAUTION

This equipment contains components that are sensitive to damage by ESD. Improper handling will result in component and assembly failure. Use extreme caution when handling. Refer to DOD-HDBK-263 for proper handling procedures.

3-10. POWER SUPPLY TROUBLESHOOTING (Cont.)

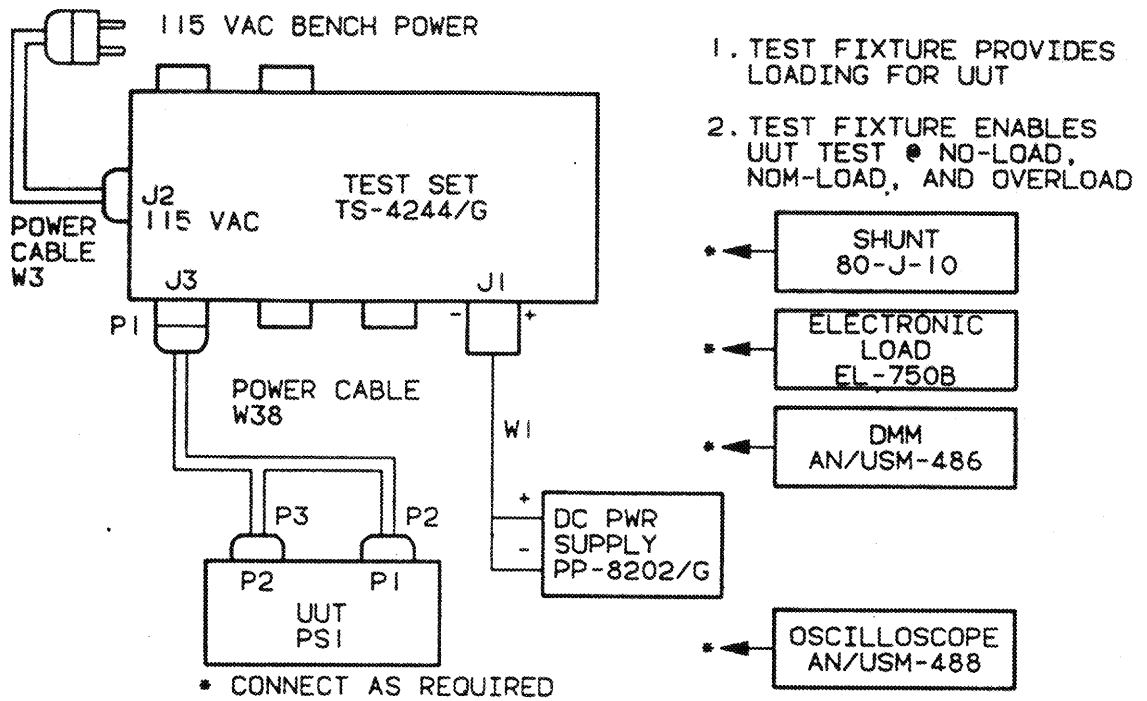

PS1 FUNCTIONAL TEST SET-UP

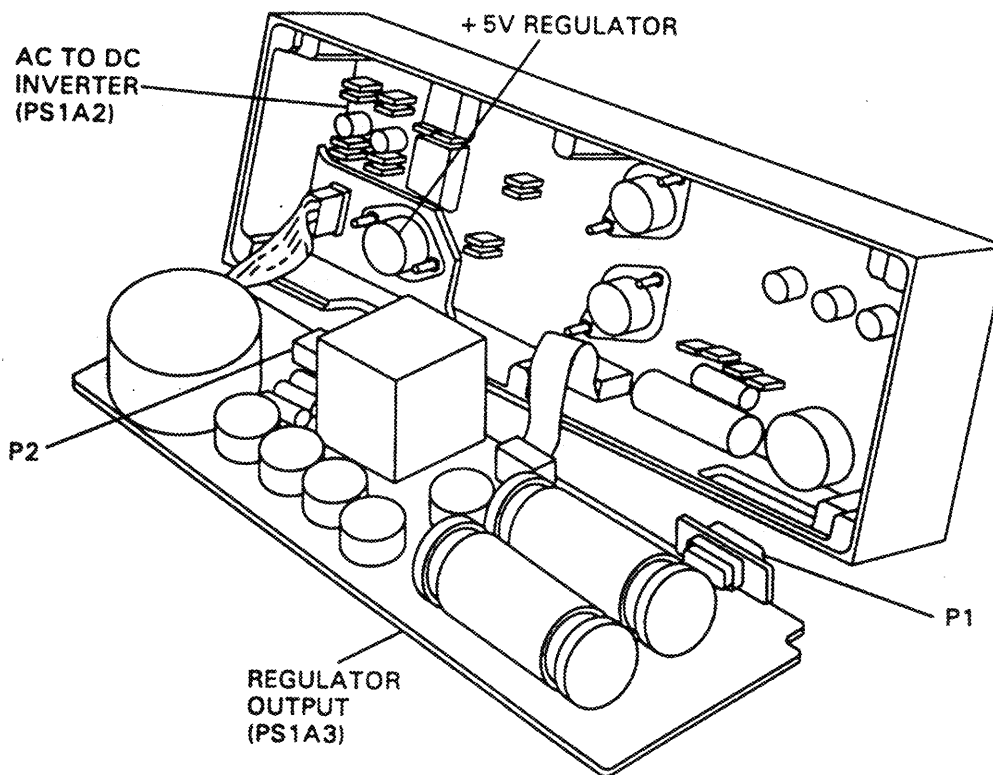

POWER SUPPLY DISASSEMBLED

3-10. POWER SUPPLY TROUBLESHOOTING (Cont.)

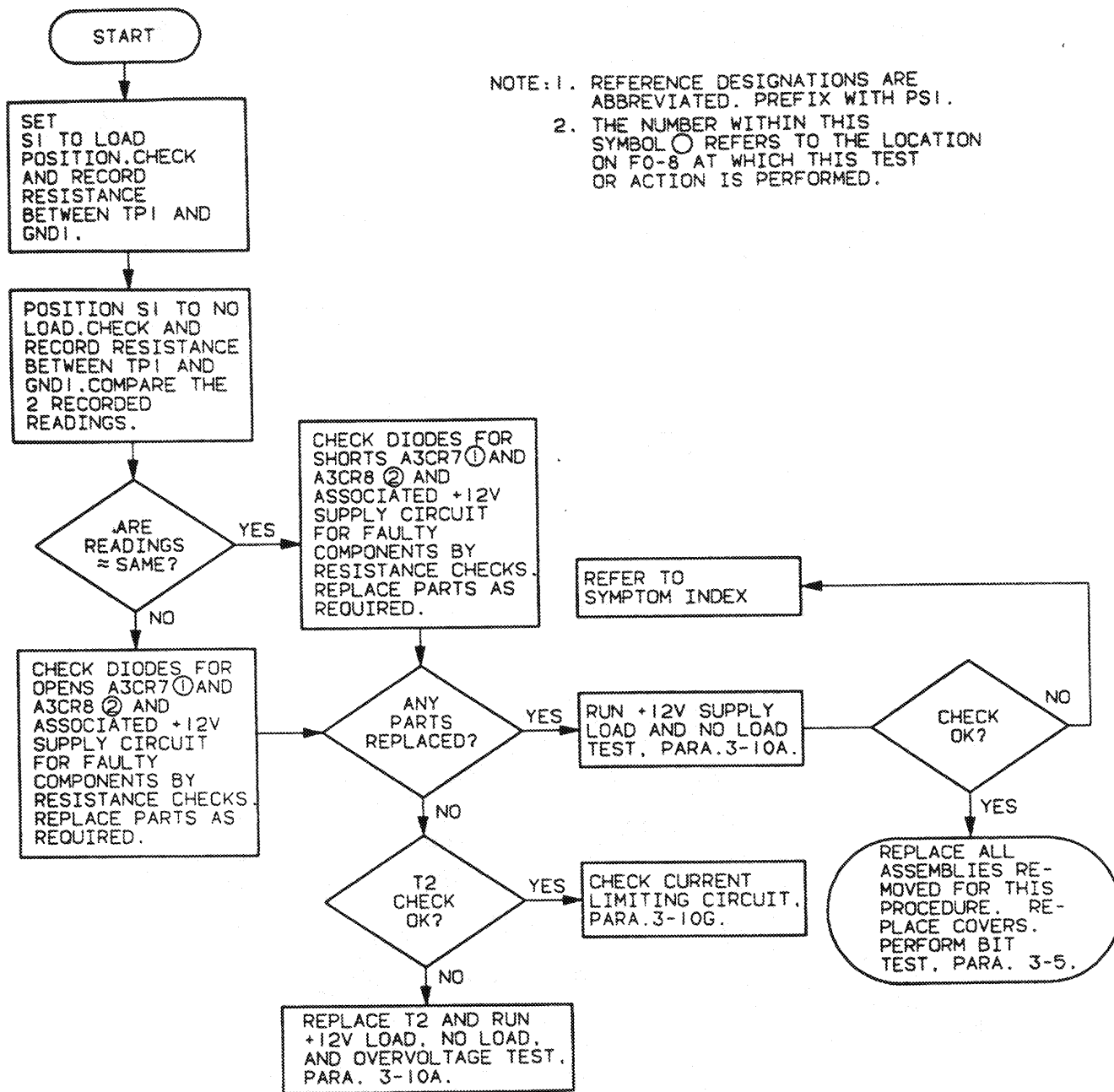

NOTE: 1. REFERENCE DESIGNATIONS ARE ABBREVIATED. PREFIX WITH PSI.
 2. THE NUMBER WITHIN THIS SYMBOL ○ REFERS TO THE LOCATION ON FO-8 AT WHICH THIS TEST OR ACTION IS PERFORMED.

3-10. POWER SUPPLY TROUBLESHOOTING (Cont.)

c. Troubleshooting +28 V Power Supply Output Circuit. This troubleshooting procedure is to be performed for failure of the NO-LOAD or LOAD Functional test. For TP callouts on troubleshooting flow charts refer to figures FO-5, FO-8, and FO-9.

INITIAL SETUP

Test Equipment

Digital Multimeter AN/USM-486
Test Set, Power Supply TS-4244/G
Oscilloscope AN/USM-488
DC Power Supply, PP-8202/G

Equipment Condition

PS1 functional test completed,
(para. 3-10)
Test fixture CB1 and CB2 OFF.
PS regulator output CCA removed
(para. 3-33) but reconnected
to ac to dc inverter

Tools

Tool Kit TK-17
Workstation, Static

WARNING

VOLTAGE is used in the operation of this equipment. DEATH ON CONTACT may result if personnel fail to observe safety precautions. Be careful not to contact high-voltage connections when testing this equipment.

CAUTION

This equipment contains components that are sensitive to damage by ESD. Improper handling will result in component and assembly failure. Use extreme caution when handling. Refer to DOD-HDBK-263 for proper handling procedures.

3-10. POWER SUPPLY TROUBLESHOOTING (Cont.)

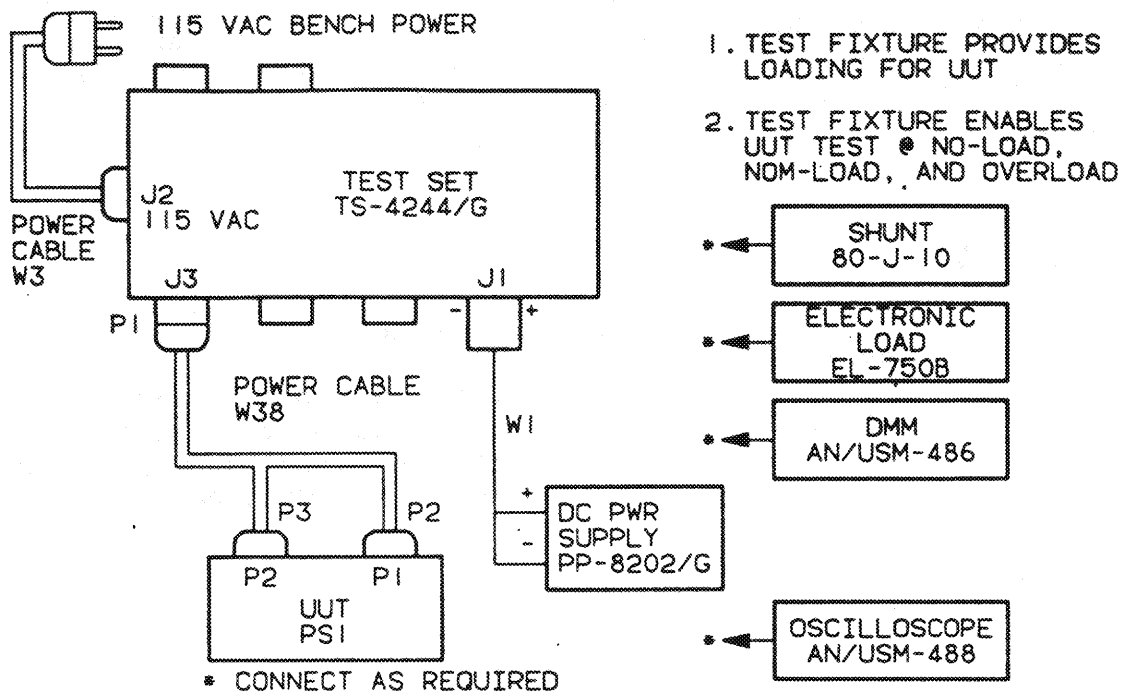

- 1. TEST FIXTURE PROVIDES LOADING FOR UUT
- 2. TEST FIXTURE ENABLES UUT TEST @ NO-LOAD, NOM-LOAD, AND OVERLOAD

PS1 FUNCTIONAL TEST SET-UP

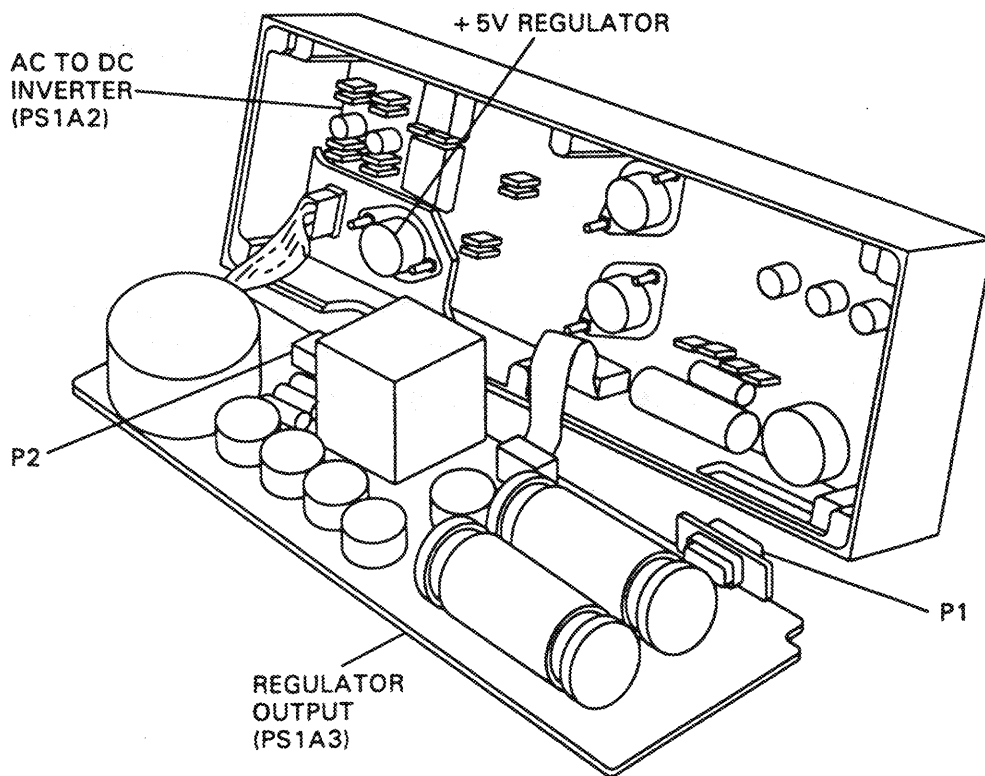

POWER SUPPLY DISASSEMBLED

3-10. POWER SUPPLY TROUBLESHOOTING (Cont.)

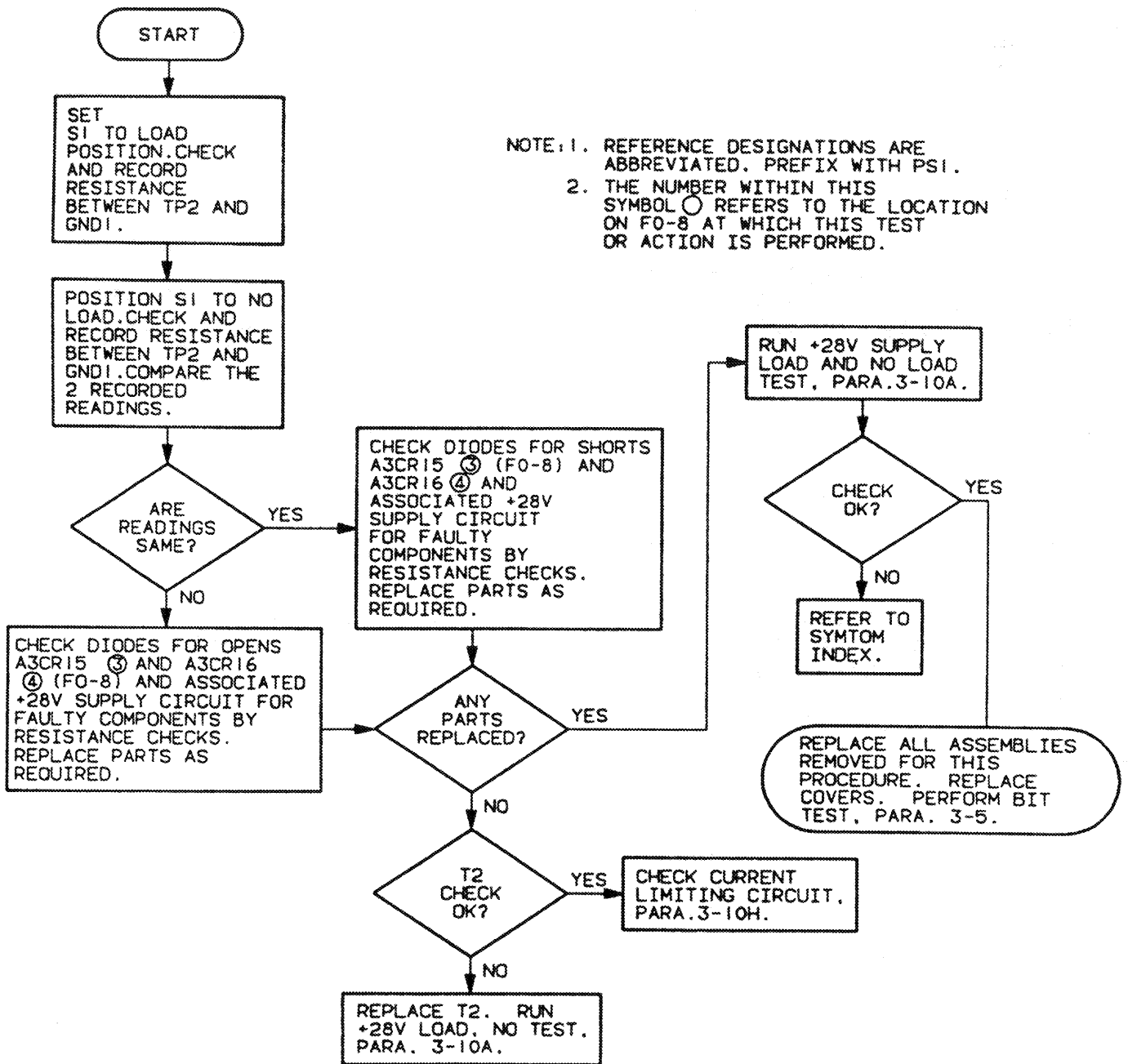

NOTE: 1. REFERENCE DESIGNATIONS ARE ABBREVIATED. PREFIX WITH PSI.
 2. THE NUMBER WITHIN THIS SYMBOL ○ REFERS TO THE LOCATION ON FO-8 AT WHICH THIS TEST OR ACTION IS PERFORMED.

3-10. POWER SUPPLY TROUBLESHOOTING (Cont.)

d. Troubleshooting +5 V Power Supply Output Circuit. This troubleshooting procedure is to be performed for failure of the NO-LOAD or LOAD Functional test. For TP callouts on troubleshooting flow charts refer to figures FO-6, FO-8, and FO-9.

INITIAL SETUP

Test Equipment

Digital Multimeter AN/USM-486
 Test Set, Power Supply TS-4244/G
 Oscilloscope AN/USM-488
 DC Power Supply, PP-8202/G

Equipment Condition

PS1 functional test completed,
 (para. 3-10)
 Test fixture CB1 and CB2 OFF.
 PS regulator output CCA removed
 (para. 3-33) but reconnected
 to ac to dc inverter

Tools

Tool Kit TK-17
 Workstation, Static

WARNING

VOLTAGE is used in the operation of this equipment. DEATH ON CONTACT may result if personnel fail to observe safety precautions. Be careful not to contact high-voltage connections when testing this equipment.

CAUTION

This equipment contains components that are sensitive to damage by ESD. Improper handling will result in component and assembly failure. Use extreme caution when handling. Refer to DOD-HDBK-263 for proper handling procedures.

3-10. POWER SUPPLY TROUBLESHOOTING (Cont.)

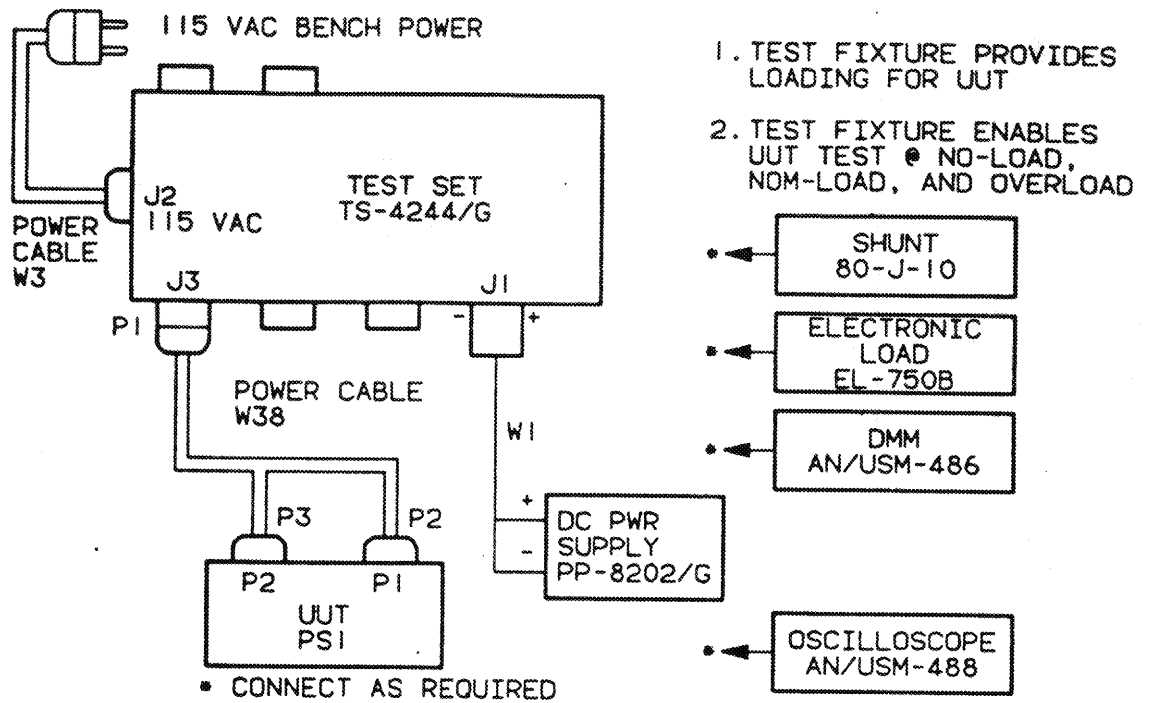

PS1 FUNCTIONAL TEST SET-UP

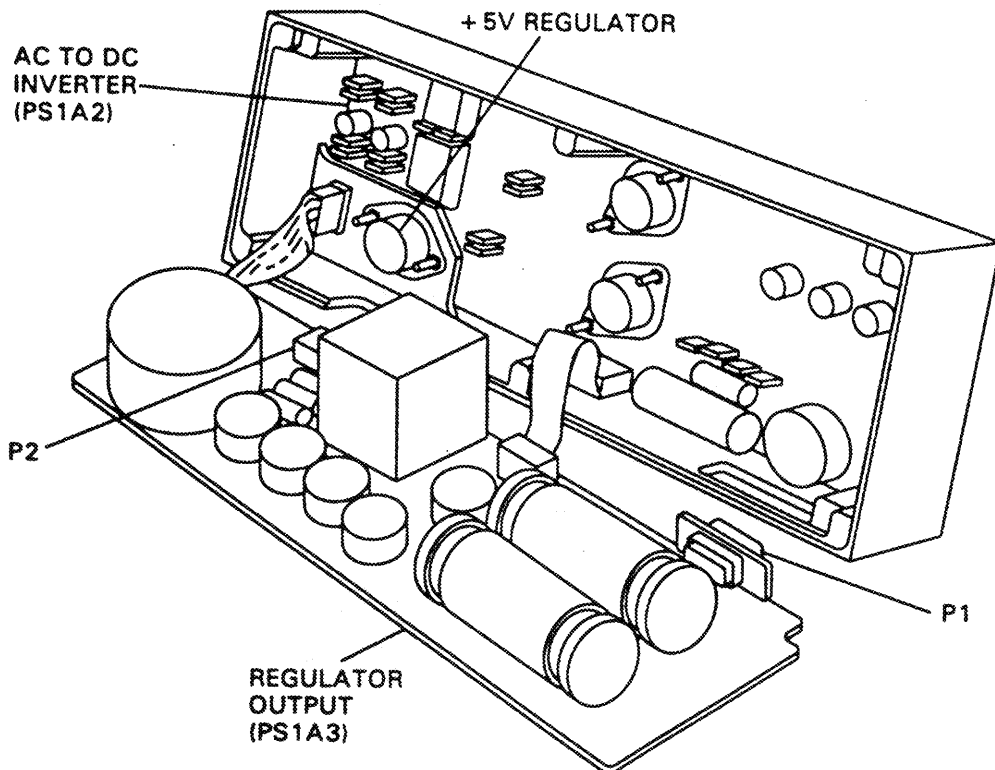

POWER SUPPLY DISASSEMBLED

3-10. POWER SUPPLY TROUBLESHOOTING (Cont.)

e. Troubleshooting -12 V Power Supply Output Circuit. This troubleshooting procedure is to be performed for failure of the NO-LOAD or LOAD Functional test. For TP callouts on troubleshooting flow charts refer to figures FO-5, FO-8, and FO-9.

INITIAL SETUP

Test Equipment

Digital Multimeter AN/USM-486
Test Set, Power Supply TS-4244/G
Oscilloscope AN/USM-488
DC Power Supply, PP-8202/G

Tools

Tool Kit TK-17
Workstation, Static

Equipment Condition

PS1 functional test completed,
(para. 3-10)
Test fixture CB1 and CB2 OFF.
PS regulator output CCA removed
(para. 3-33) but reconnected
to ac to dc inverter

WARNING

VOLTAGE is used in the operation of this equipment. DEATH ON CONTACT may result if personnel fail to observe safety precautions. Be careful not to contact high-voltage connections when testing this equipment.

CAUTION

This equipment contains components that are sensitive to damage by ESD. Improper handling will result in component and assembly failure. Use extreme caution when handling. Refer to DOD-HDBK-263 for proper handling procedures.

3-10. POWER SUPPLY TROUBLESHOOTING (Cont.)

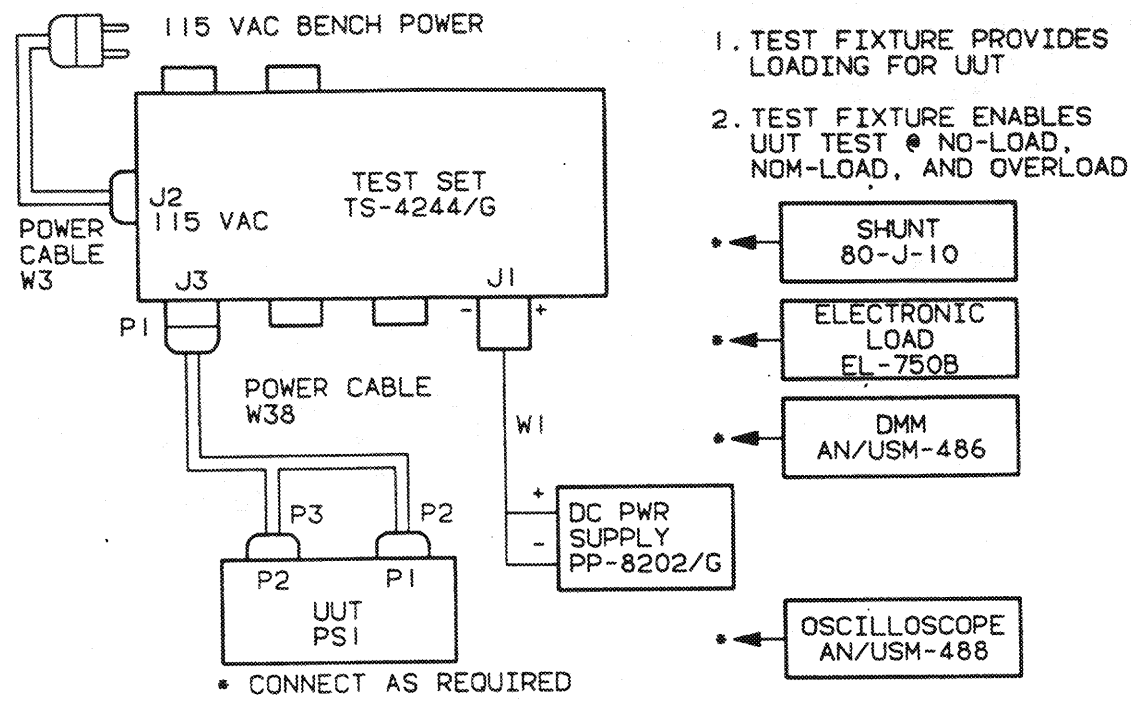

PS1 FUNCTIONAL TEST SET-UP

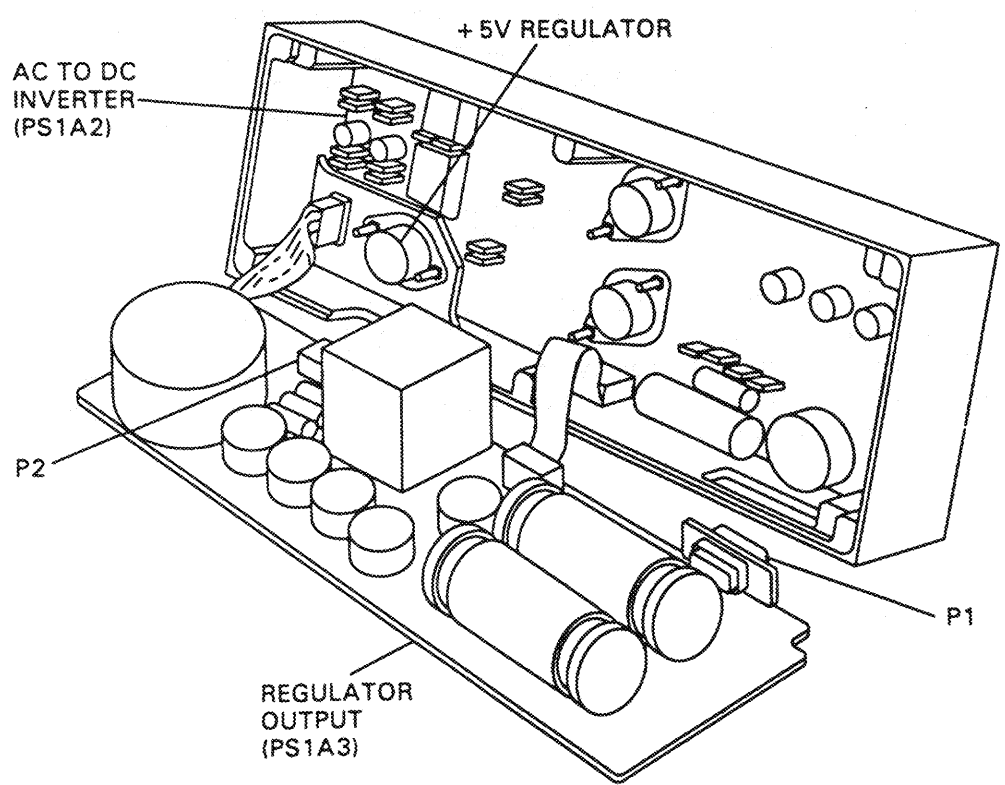

POWER SUPPLY DISASSEMBLED

3-10. POWER SUPPLY TROUBLESHOOTING (Cont.)

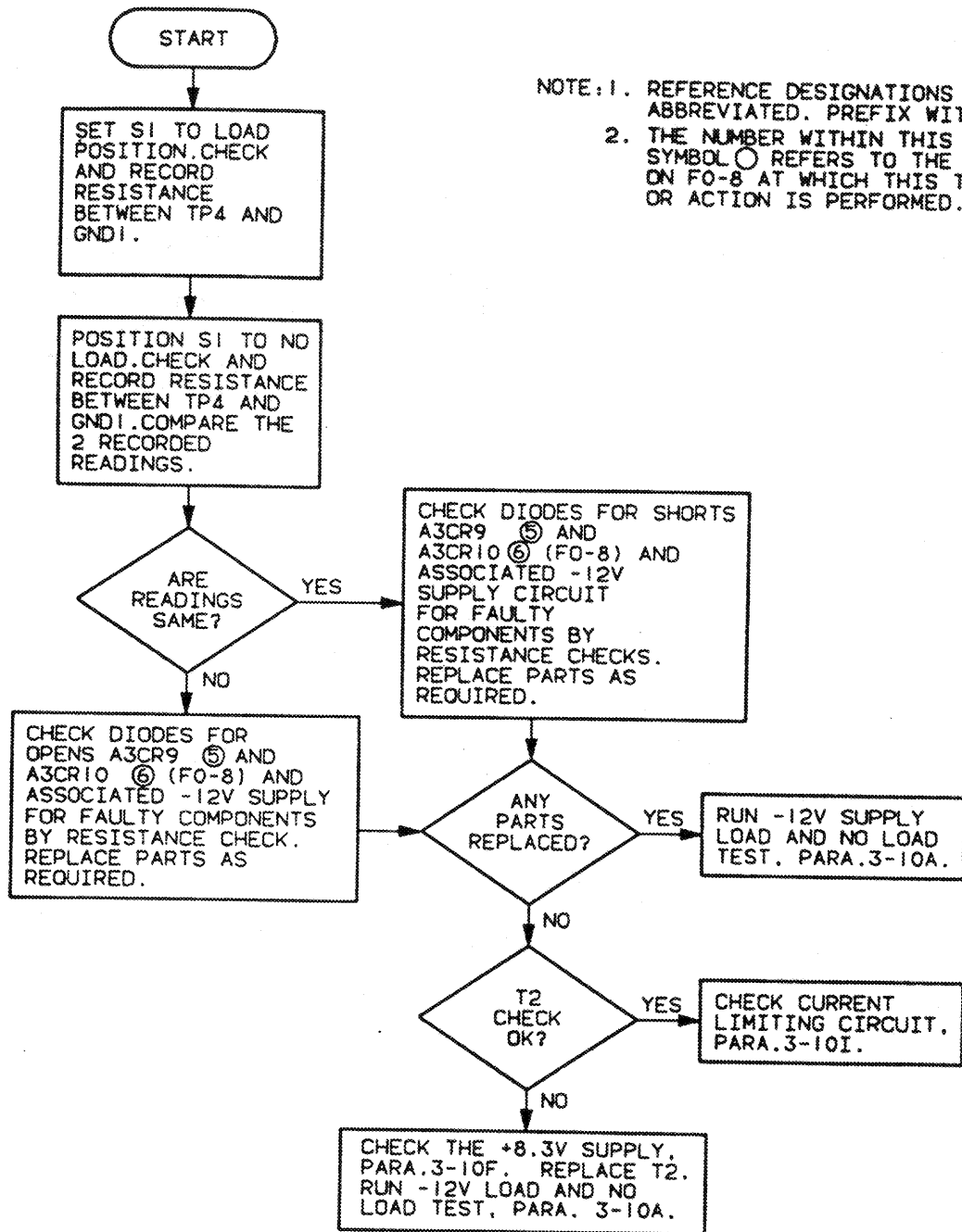

NOTE: 1. REFERENCE DESIGNATIONS ARE ABBREVIATED. PREFIX WITH PSI.
 2. THE NUMBER WITHIN THIS SYMBOL ○ REFERS TO THE LOCATION ON FO-8 AT WHICH THIS TEST OR ACTION IS PERFORMED.

3-10. POWER SUPPLY TROUBLESHOOTING (Cont.)

f. Troubleshooting +8.3 V Power Supply Output Circuit. This troubleshooting procedure is to be performed for failure of the NO-LOAD or LOAD Functional test. For TP callouts on troubleshooting flow charts refer to figures FO-5, FO-8, and FO-9.

INITIAL SETUP

Test Equipment

Digital Multimeter AN/USM-486
Test Set, Power Supply TS-4244/G
Oscilloscope AN/USM-488
DC Power Supply, PP-8202/G

Equipment Condition

PS1 functional test completed,
(para. 3-10)
Test fixture CB1 and CB2 OFF.
PS regulator output CCA removed
(para. 3-33) but reconnected
to ac to dc inverter

Tools

Tool Kit TK-17
Workstation, Static

WARNING

VOLTAGE is used in the operation of this equipment. DEATH ON CONTACT may result if personnel fail to observe safety precautions. Be careful not to contact high-voltage connections when testing this equipment.

CAUTION

This equipment contains components that are sensitive to damage by ESD. Improper handling will result in component and assembly failure. Use extreme caution when handling. Refer to DOD-HDBK-263 for proper handling procedures.

3-10. POWER SUPPLY TROUBLESHOOTING (Cont.)

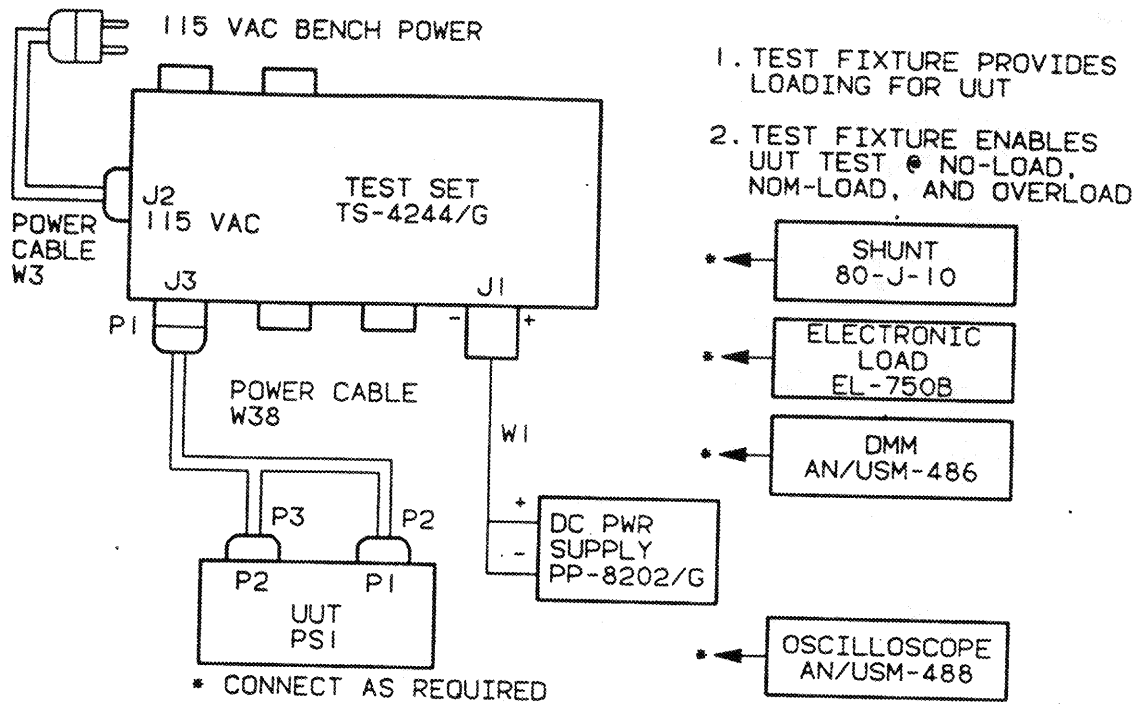

PS1 FUNCTIONAL TEST SET-UP

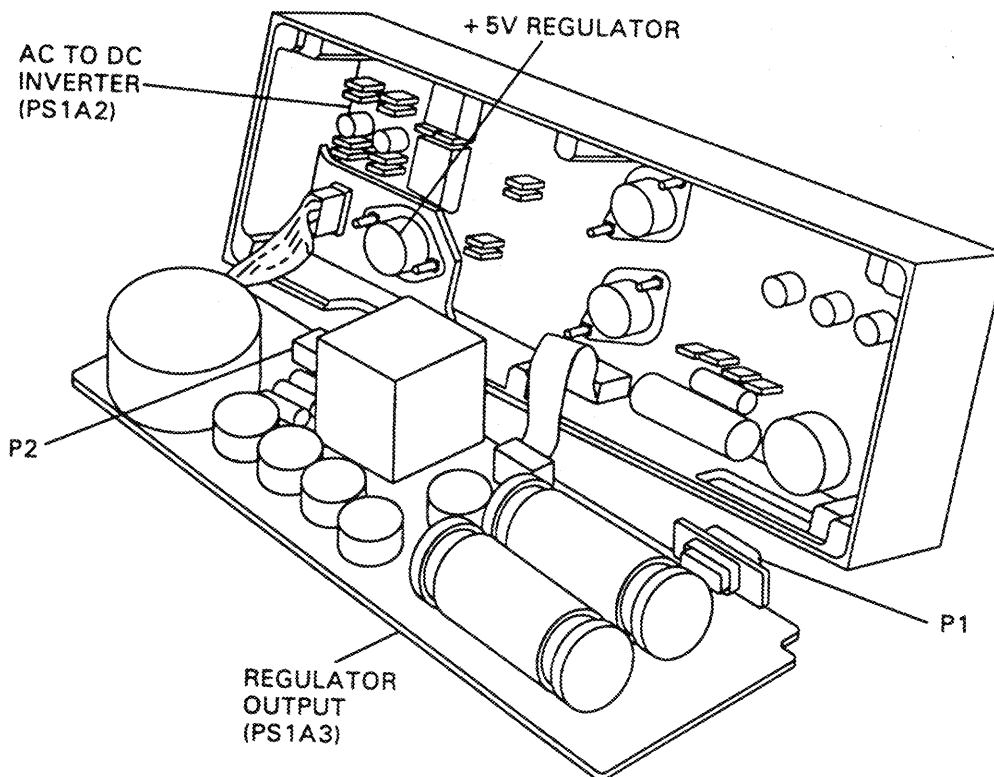

POWER SUPPLY DISASSEMBLED

3-10. POWER SUPPLY TROUBLESHOOTING (Cont.)

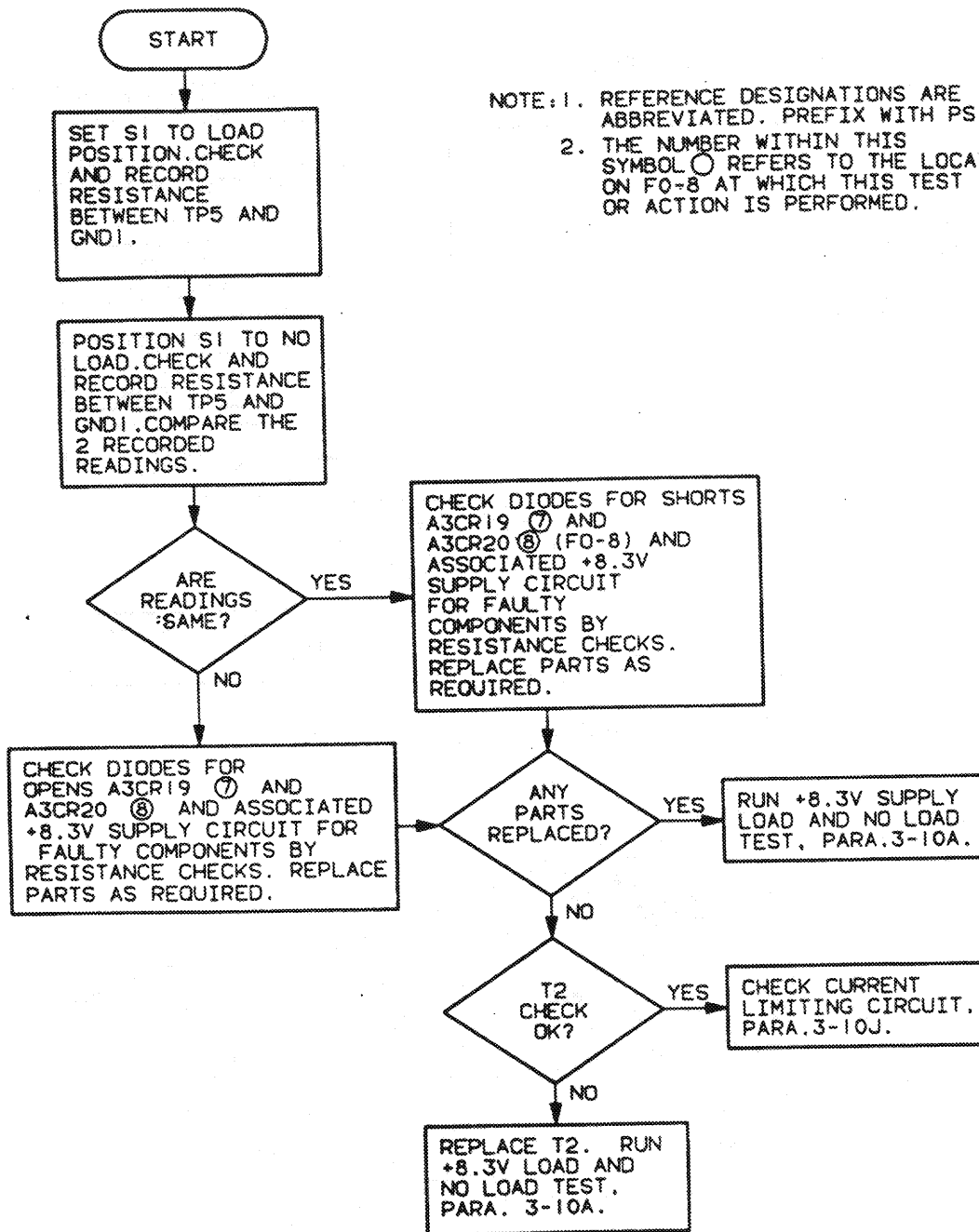

NOTE: 1. REFERENCE DESIGNATIONS ARE ABBREVIATED. PREFIX WITH PSI.
 2. THE NUMBER WITHIN THIS SYMBOL ○ REFERS TO THE LOCATION ON FO-8 AT WHICH THIS TEST OR ACTION IS PERFORMED.

3-10. POWER SUPPLY TROUBLESHOOTING (Cont.)

g. Troubleshooting +12 V Current Limiting Circuit. For TP callouts on troubleshooting flow charts refer to figures FO-5, FO-8, and FO-9.

NOTE

Instructions in this procedure may require performing the power supply functional test. However, only the portion of the test that failed and directed the technician to this troubleshooting procedure needs to be run again.

INITIAL SETUP

Test Equipment

Digital Multimeter AN/USM-486
Test Set, Power Supply TS-4244/G
Oscilloscope AN/USM-488
DC Power Supply, PP-8202/G

Tools

Tool Kit TK-17
Workstation, Static

Equipment Condition

PS1 functional test completed,
(para. 3-10)
Test fixture CB1 and CB2 OFF,
S1 set to LOAD.
PS regulator output CCA removed
(para. 3-33) but reconnected
to ac to dc inverter

WARNING

VOLTAGE is used in the operation of this equipment. DEATH ON CONTACT may result if personnel fail to observe safety precautions. Be careful not to contact high-voltage connections when testing this equipment.

CAUTION

This equipment contains components that are sensitive to damage by ESD. Improper handling will result in component and assembly failure. Use extreme caution when handling. Refer to DOD-HDBK-263 for proper handling procedures.

3-10. POWER SUPPLY TROUBLESHOOTING (Cont.)

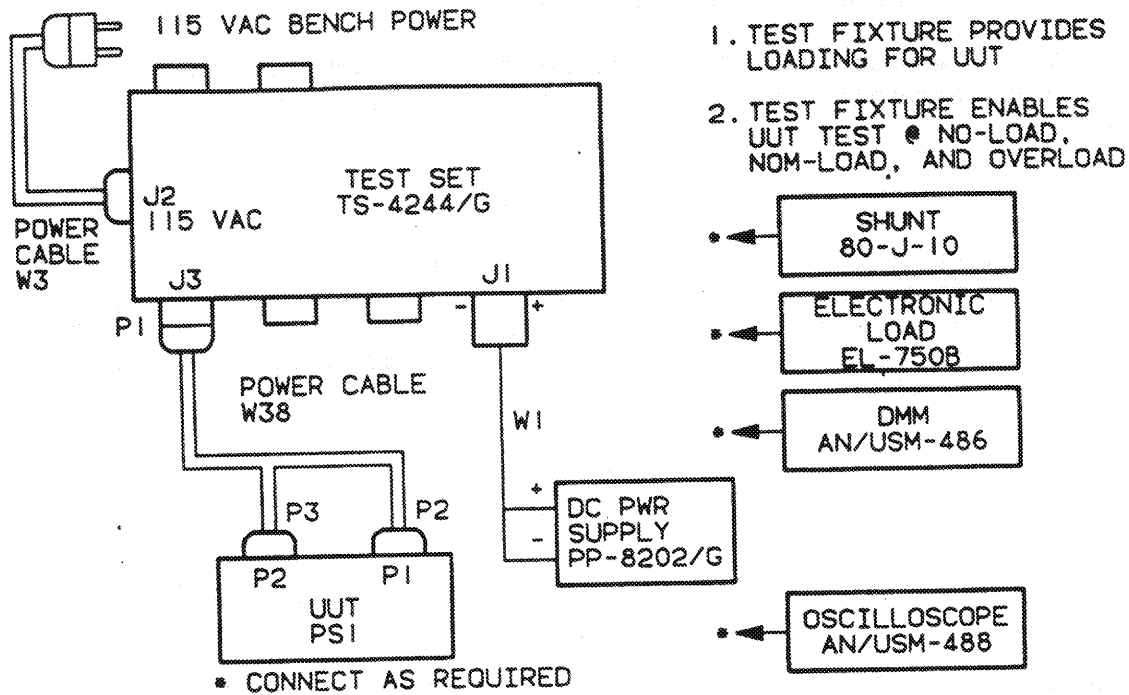

PS1 FUNCTIONAL TEST SET-UP

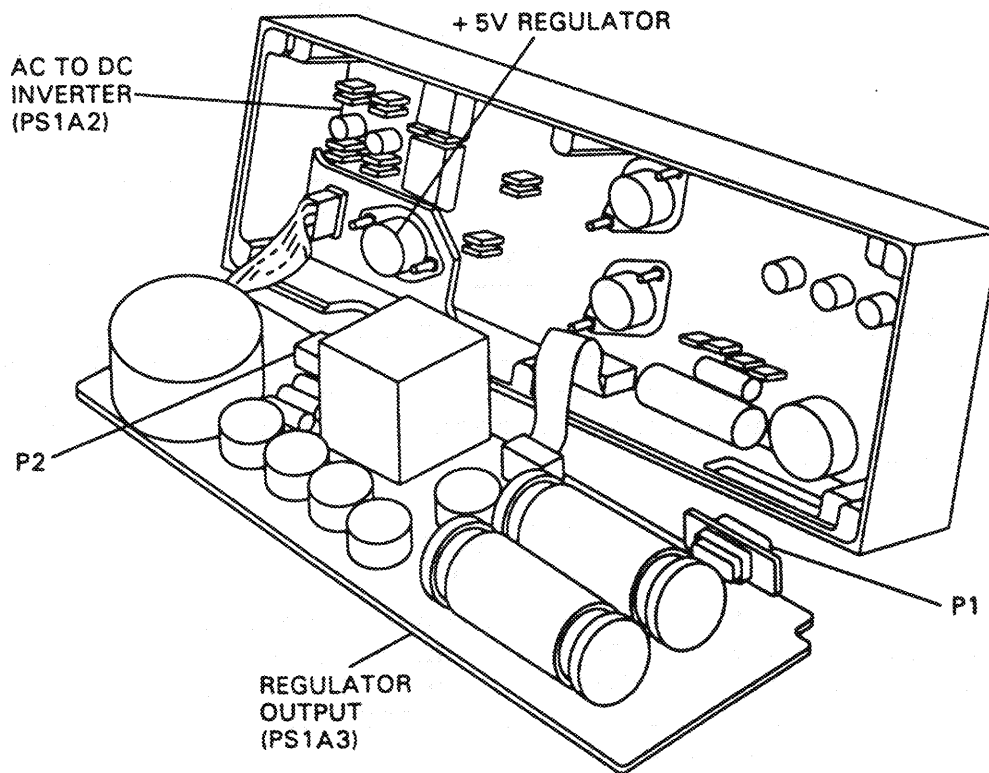

POWER SUPPLY DISASSEMBLED

3-10. POWER SUPPLY TROUBLESHOOTING (Cont.)

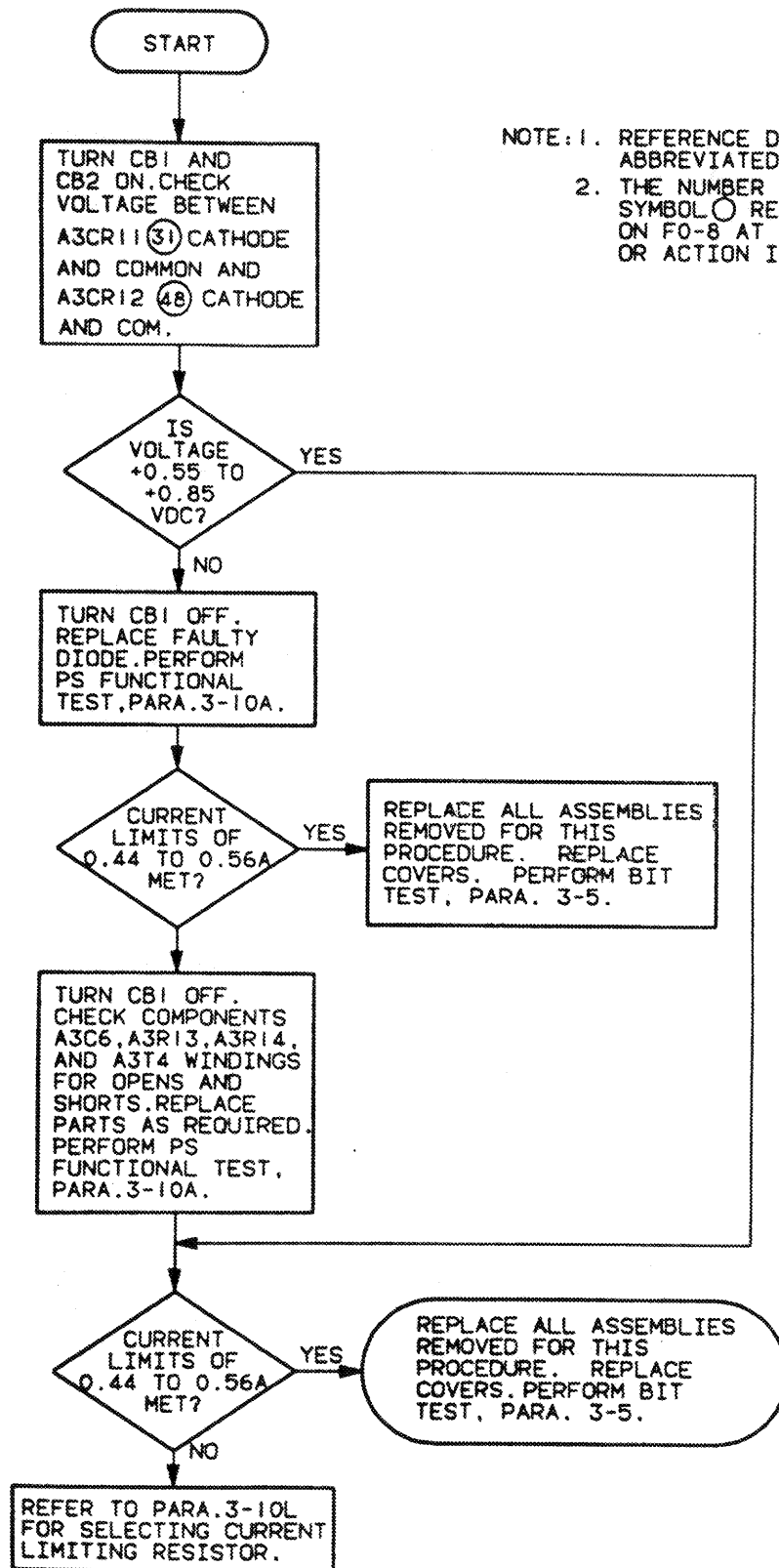

NOTE: 1. REFERENCE DESIGNATIONS ARE ABBREVIATED. PREFIX WITH PS
 2. THE NUMBER WITHIN THIS SYMBOL ○ REFERS TO THE LOCA ON FO-8 AT WHICH THIS TEST OR ACTION IS PERFORMED.

3-10. POWER SUPPLY TROUBLESHOOTING (Cont.)

h. Troubleshooting +28 V Current Limiting Circuit. For TP callouts on troubleshooting flow charts refer to figures FO-5, FO-8, and FO-9.

NOTE

Instructions in this procedure may require performing the power supply functional test. However, only the portion of the test that failed and directed the technician to this troubleshooting procedure needs to be run again.

INITIAL SETUP

Test Equipment

Digital Multimeter AN/USM-486
Test Set, Power Supply TS-4244/G
Oscilloscope AN/USM-488
DC Power Supply, PP-8202/G

Equipment Condition

PS1 functional test completed,
(para. 3-10)
Test fixture CB1 and CB2 OFF,
S1 set to LOAD.
PS regulator output CCA removed
(para. 3-33) but reconnected
to ac to dc inverter

Tools

Tool Kit TK-17
Workstation, Static

WARNING

VOLTAGE is used in the operation of this equipment. DEATH ON CONTACT may result if personnel fail to observe safety precautions. Be careful not to contact high-voltage connections when testing this equipment.

CAUTION

This equipment contains components that are sensitive to damage by ESD. Improper handling will result in component and assembly failure. Use extreme caution when handling. Refer to DOD-HDBK-263 for proper handling procedures.

3-10. POWER SUPPLY TROUBLESHOOTING (Cont.)

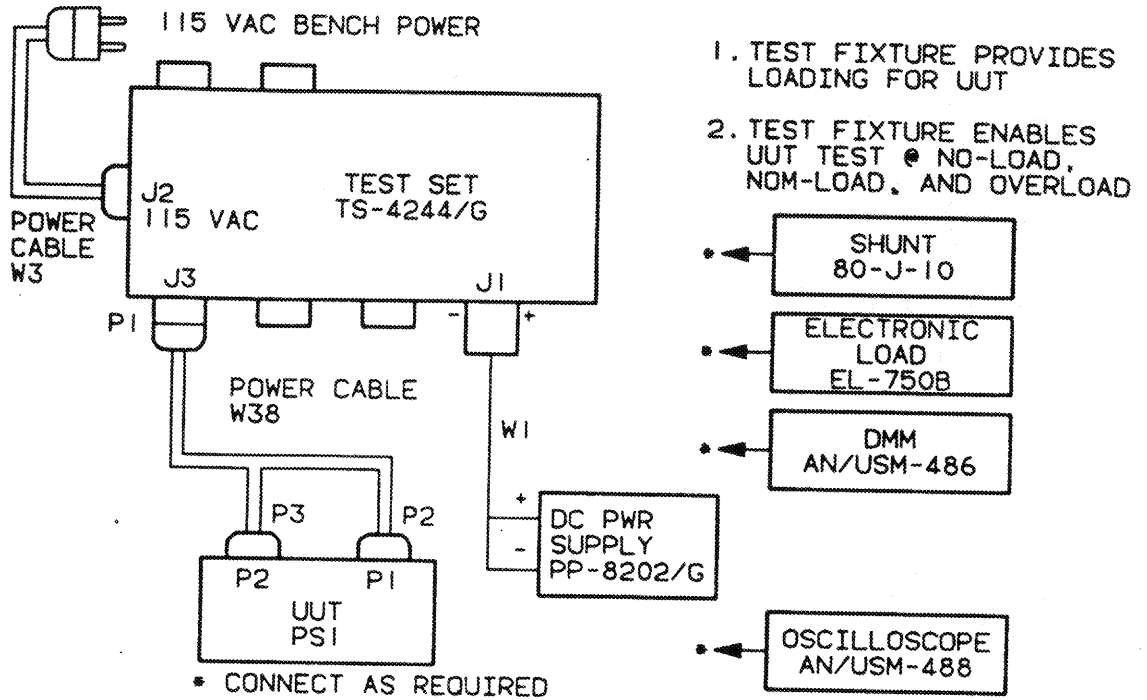

PS1 FUNCTIONAL TEST SET-UP

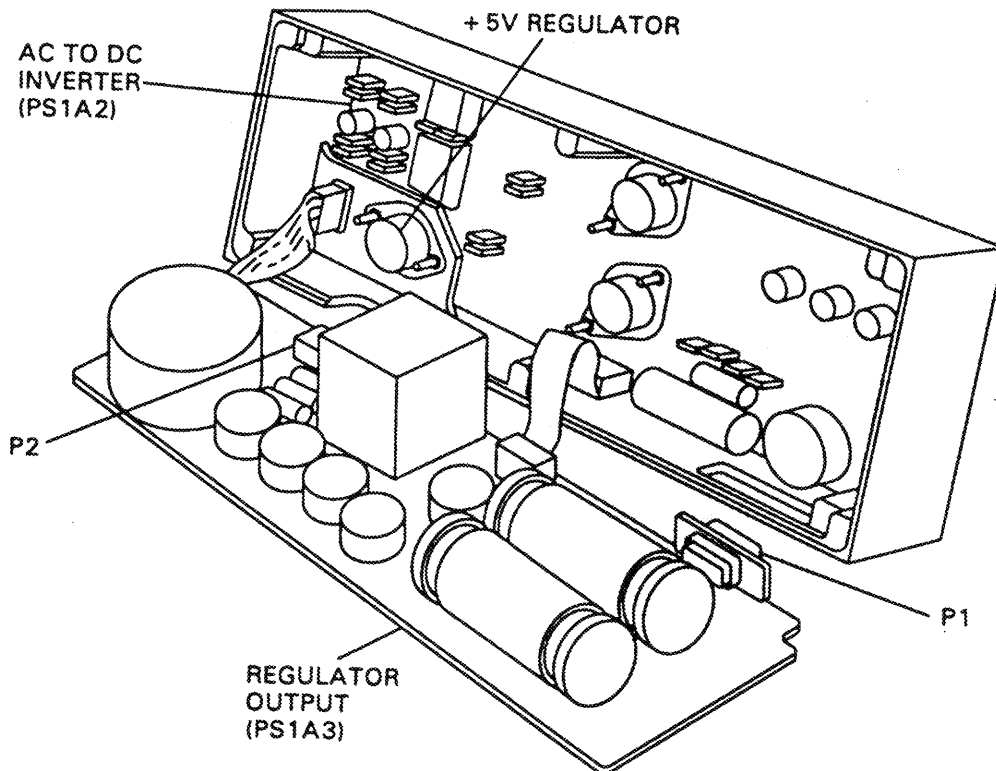

POWER SUPPLY DISASSEMBLED

3-10. POWER SUPPLY TROUBLESHOOTING (Cont.)

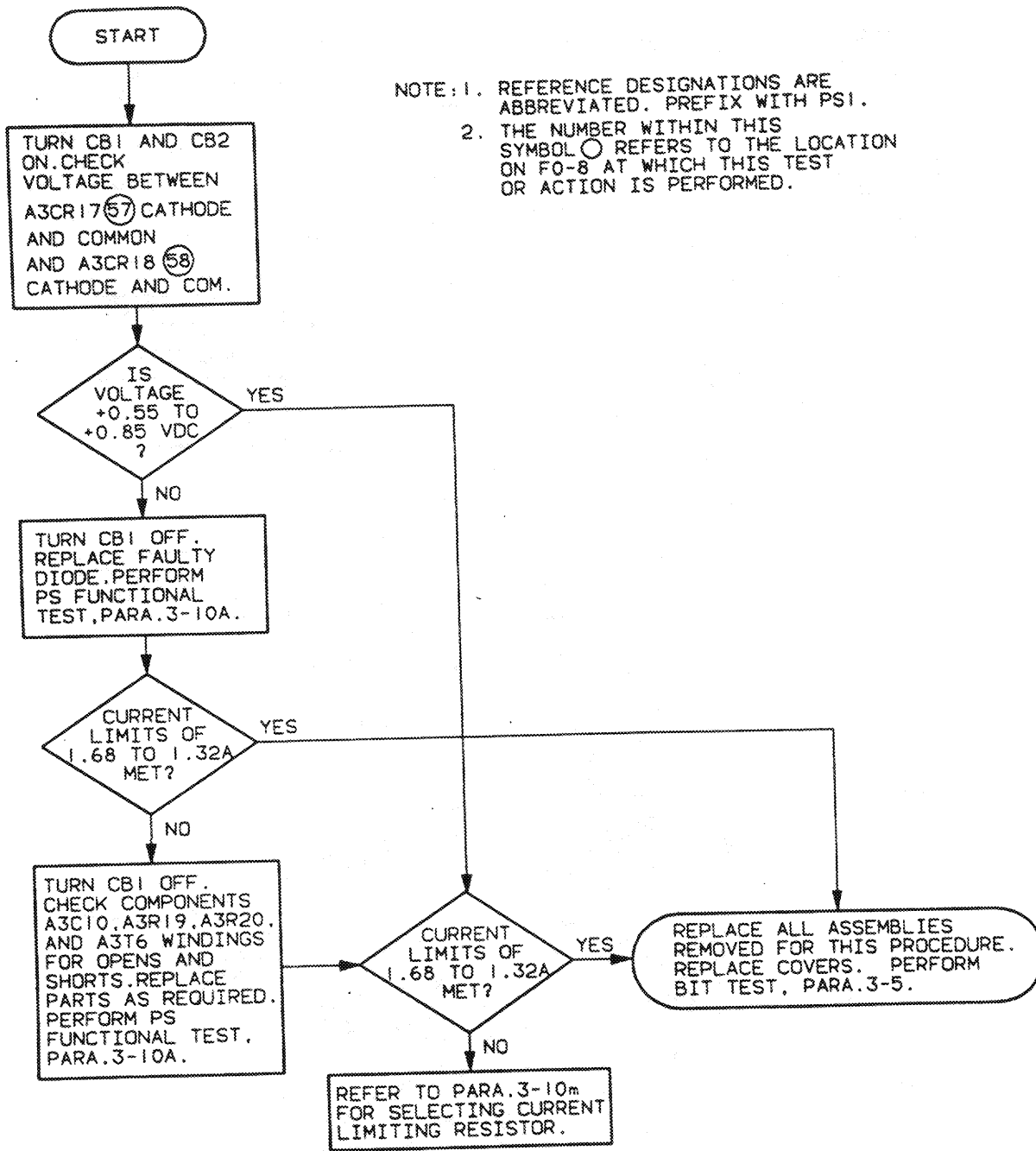

NOTE: 1. REFERENCE DESIGNATIONS ARE ABBREVIATED. PREFIX WITH PSI.
 2. THE NUMBER WITHIN THIS SYMBOL ○ REFERS TO THE LOCATION ON FO-8 AT WHICH THIS TEST OR ACTION IS PERFORMED.

3-10. POWER SUPPLY TROUBLESHOOTING (Cont.)

i. Troubleshooting -12 V Current Limiting Circuit. For TP callouts on troubleshooting flow charts refer to figures FO-5, FO-8, and FO-9.

NOTE

Instructions in this procedure may require performing the power supply functional test. However, only the portion of the test that failed and directed the technician to this troubleshooting procedure needs to be run again.

INITIAL SETUP

Test Equipment

Digital Multimeter AN/USM-486
Test Set, Power Supply TS-4244/G
Oscilloscope AN/USM-488
DC Power Supply, PP-8202/G

Tools

Tool Kit TK-17
Workstation, Static

Equipment Condition

PS1 functional test completed,
(para. 3-10)
Test fixture CB1 and CB2 OFF,
S1 set to LOAD.
PS regulator output CCA removed
(para. 3-33) but reconnected
to ac to dc inverter

WARNING

VOLTAGE is used in the operation of this equipment. DEATH ON CONTACT may result if personnel fail to observe safety precautions. Be careful not to contact high-voltage connections when testing this equipment.

CAUTION

This equipment contains components that are sensitive to damage by ESD. Improper handling will result in component and assembly failure. Use extreme caution when handling. Refer to DOD-HDBK-263 for proper handling procedures.

-10. POWER SUPPLY TROUBLESHOOTING (Cont.)

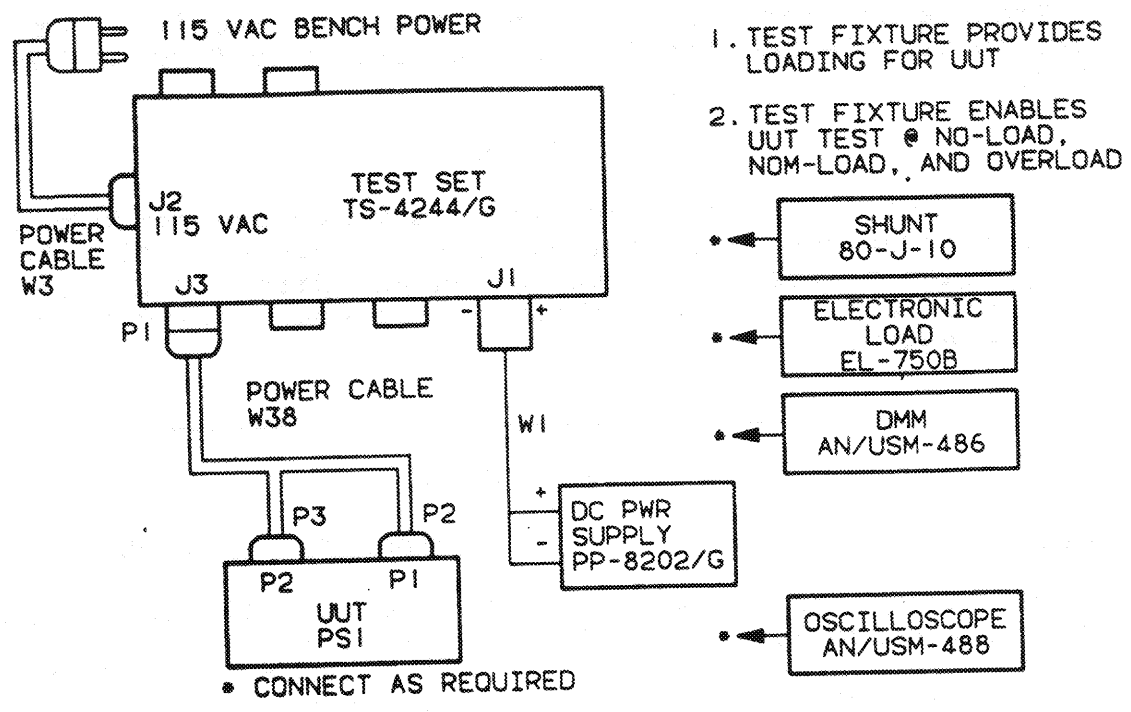

- 1. TEST FIXTURE PROVIDES LOADING FOR UUT
- 2. TEST FIXTURE ENABLES UUT TEST @ NO-LOAD, NOM-LOAD, AND OVERLOAD

PS1 FUNCTIONAL TEST SET-UP

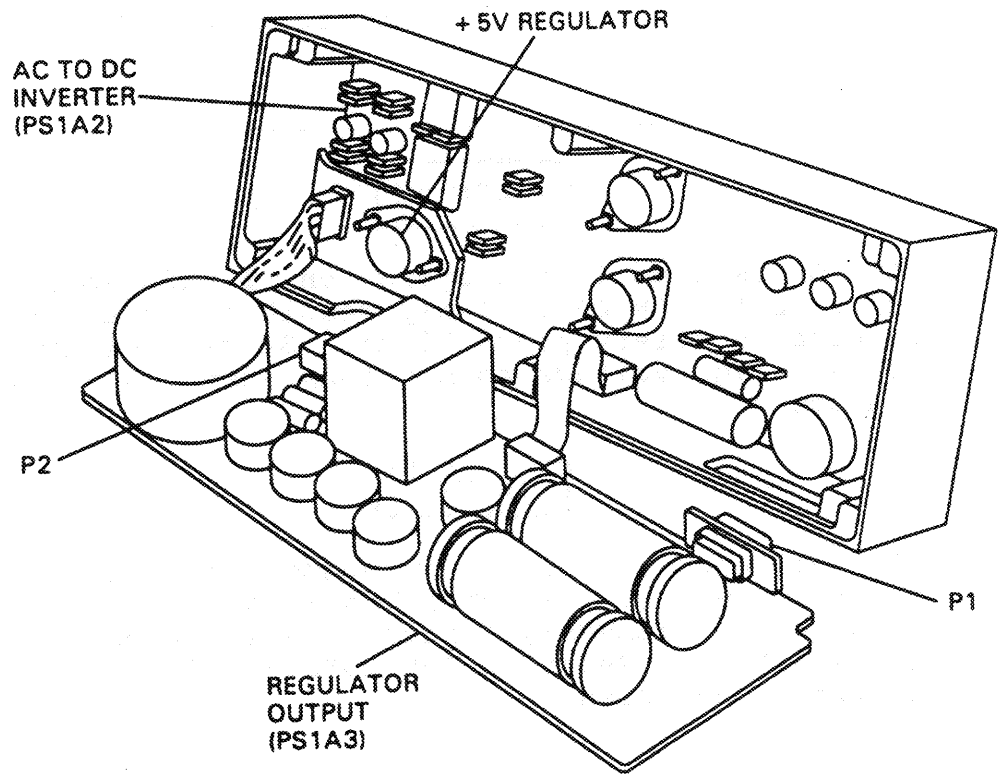

POWER SUPPLY DISASSEMBLED

3-10. POWER SUPPLY TROUBLESHOOTING (Cont.)

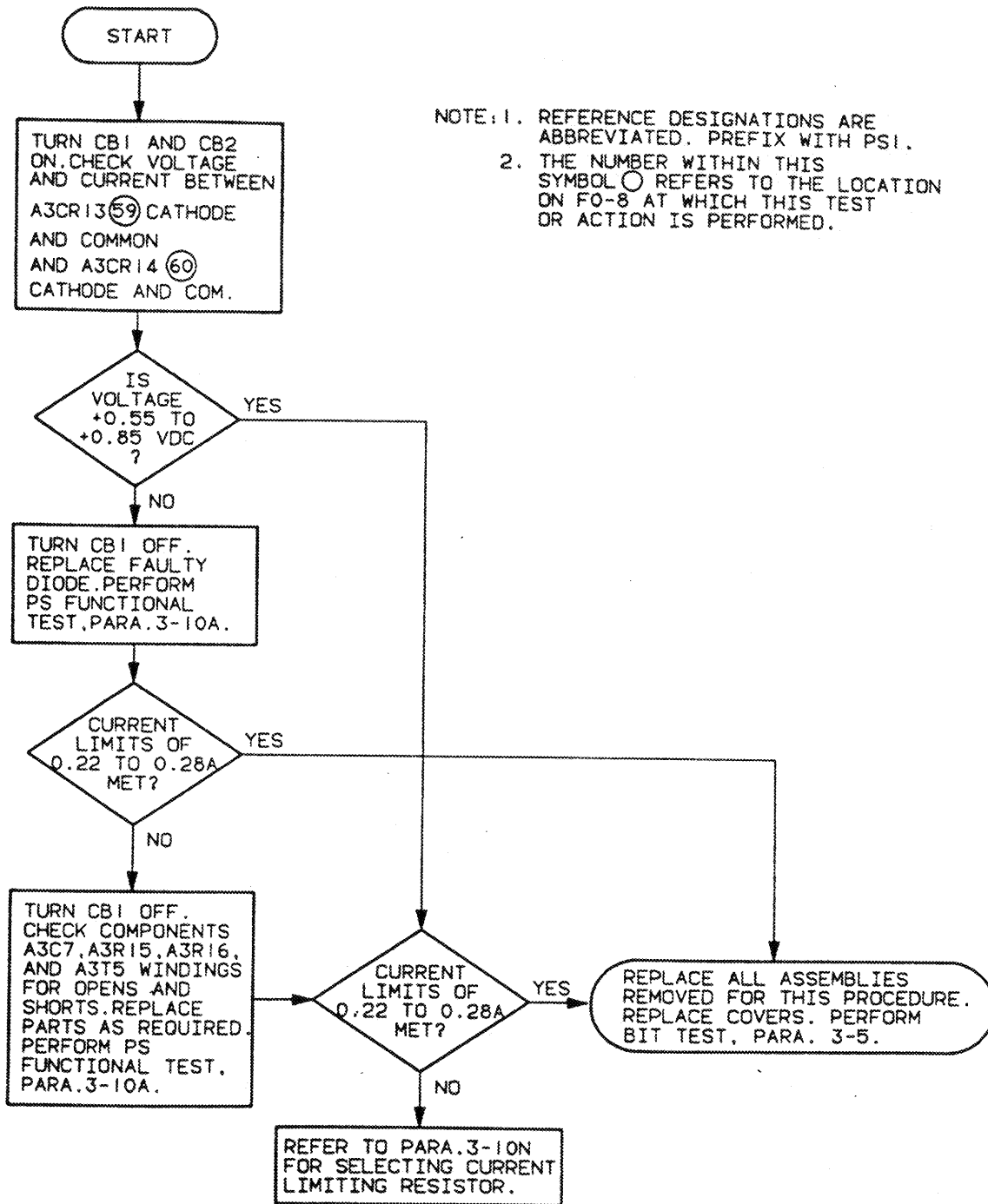

3-10. POWER SUPPLY TROUBLESHOOTING (Cont.)

j. Troubleshooting +8.3 V Current Limiting Circuit. For TP callouts on troubleshooting flow charts refer to figures FO-5, FO-8, and FO-9.

NOTE

Instructions in this procedure may require performing the power supply functional test. However, only the portion of the test that failed and directed the technician to this troubleshooting procedure needs to be run again.

INITIAL SETUP

Test Equipment

Digital Multimeter AN/USM-486
 Test Set, Power Supply TS-4244/G
 Oscilloscope AN/USM-488
 DC Power Supply, PP-8202/G

Equipment Condition

PS1 functional test completed,
 (para. 3-10)
 Test fixture CB1 and CB2 OFF,
 S1 set to LOAD.
 PS regulator output CCA removed
 (para. 3-33) but reconnected
 to ac to dc inverter

Tools

Tool Kit TK-17
 Workstation, Static

WARNING

VOLTAGE is used in the operation of this equipment. DEATH ON CONTACT may result if personnel fail to observe safety precautions. Be careful not to contact high-voltage connections when testing this equipment.

CAUTION

This equipment contains components that are sensitive to damage by ESD. Improper handling will result in component and assembly failure. Use extreme caution when handling. Refer to DOD-HDBK-263 for proper handling procedures.

3-10. POWER SUPPLY TROUBLESHOOTING (Cont.)

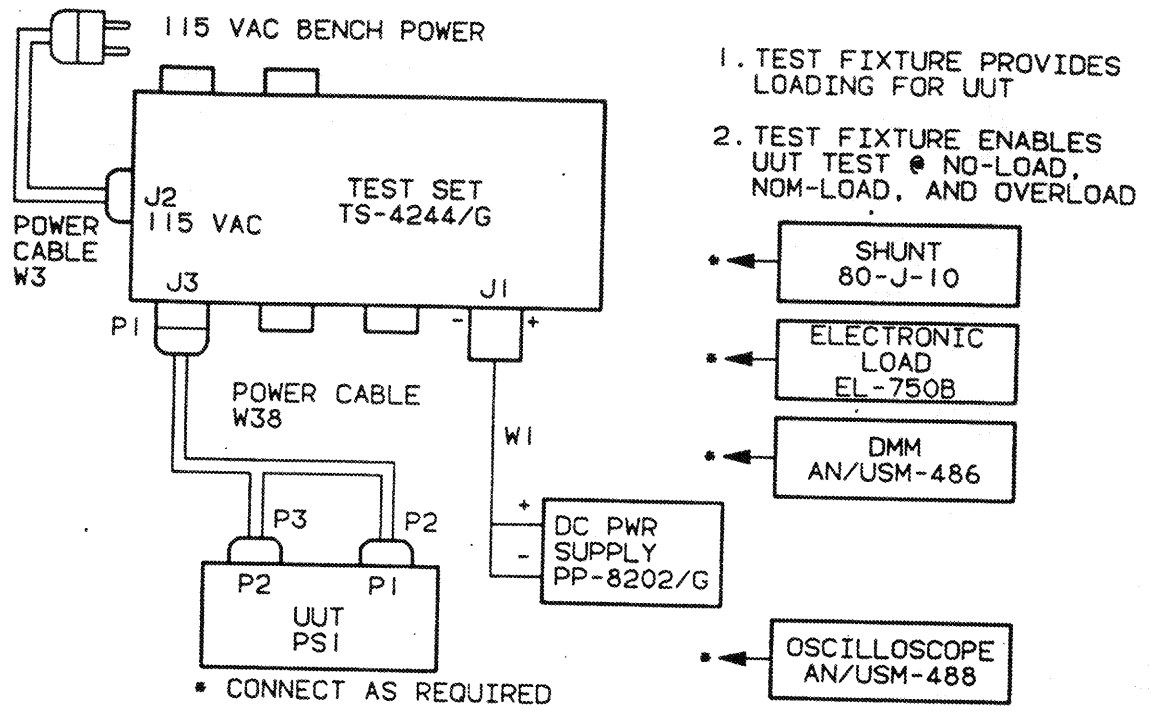

PS1 FUNCTIONAL TEST SET-UP

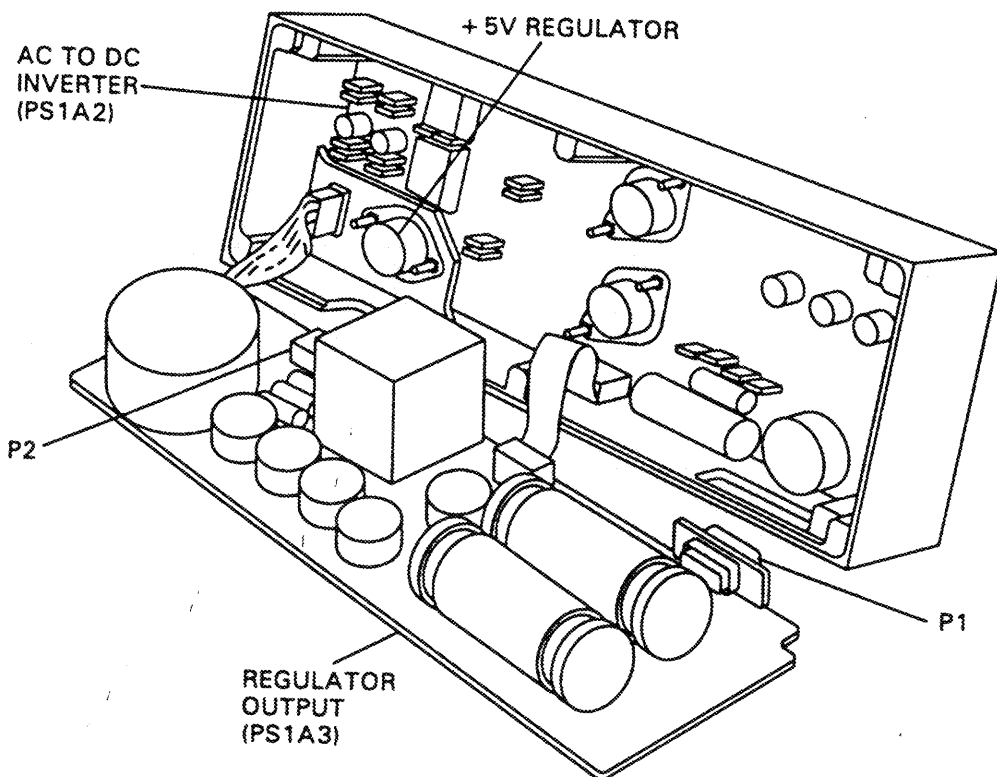

POWER SUPPLY DISASSEMBLED

3-10. POWER SUPPLY TROUBLESHOOTING (Cont.)

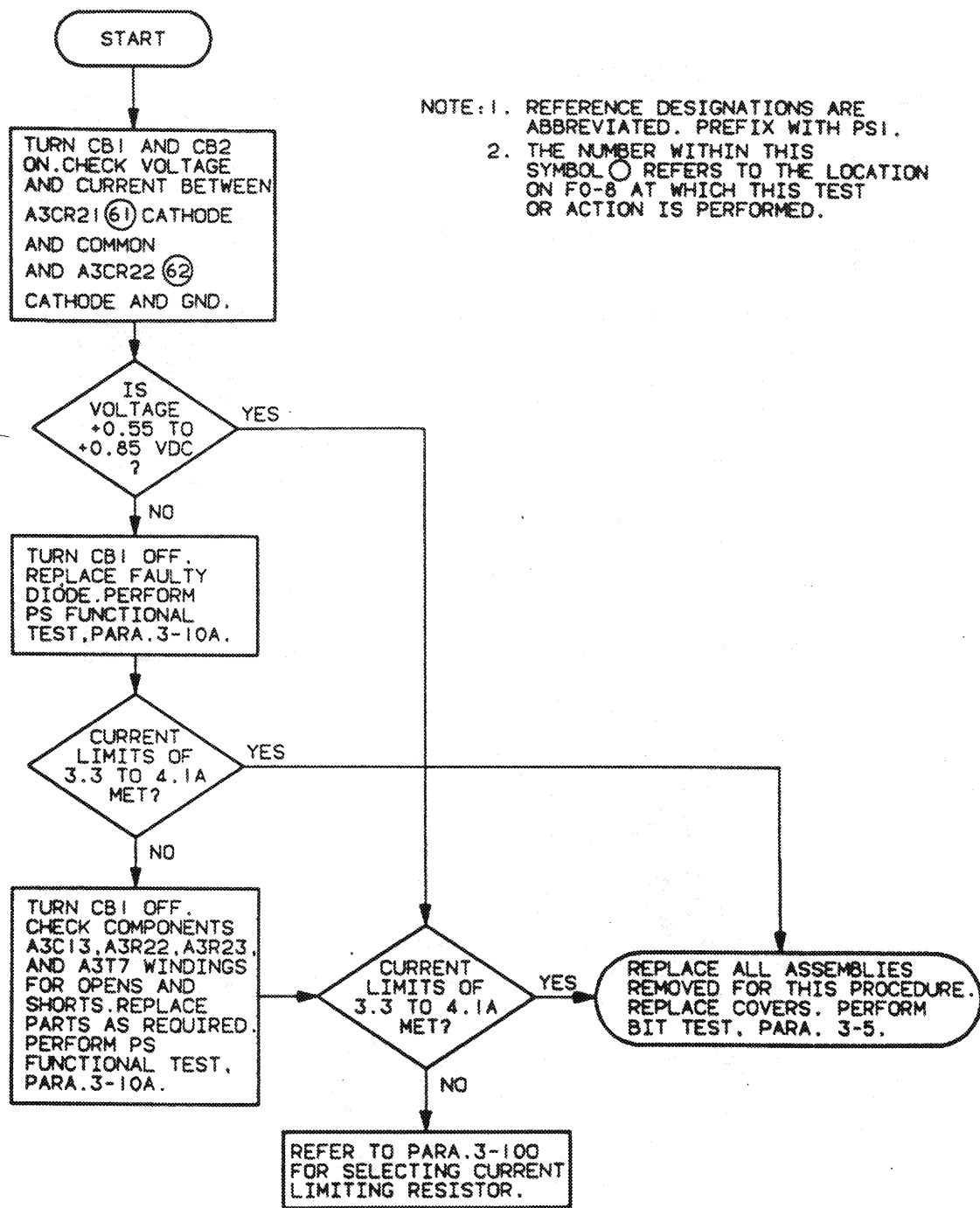

3-10. POWER SUPPLY TROUBLESHOOTING (Cont.)

k. Troubleshooting Power Transformer Current Limiting Circuit. When the various supplies all pass the current limiting test and the supply output voltages are varying, the probable cause can be trouble in the power transformer current limiting circuit. For TP callouts or troubleshooting flow charts refer to figures FO-5, FO-8, and FO-9.

INITIAL SETUP

Test Equipment

Digital Multimeter AN/USM-486
Test Set, Power Supply TS-4244/G
Oscilloscope AN/USM-488
DC Power Supply, PP-8202/G

Tools

Tool Kit TK-17
Workstation, Static

Equipment Condition

PS1 functional test completed,
(para. 3-10)
Test fixture CB1 and CB2 OFF,
S1 set to LOAD.
PS regulator output CCA removed
(para. 3-33) but reconnected
to ac to dc inverter

WARNING

VOLTAGE is used in the operation of this equipment. DEATH ON CONTACT may result if personnel fail to observe safety precautions. Be careful not to contact high-voltage connections when testing this equipment.

CAUTION

This equipment contains components that are sensitive to damage by ESD. Improper handling will result in component and assembly failure. Use extreme caution when handling. Refer to DOD-HDBK-263 for proper handling procedures.

3-10. POWER SUPPLY TROUBLESHOOTING (Cont.)

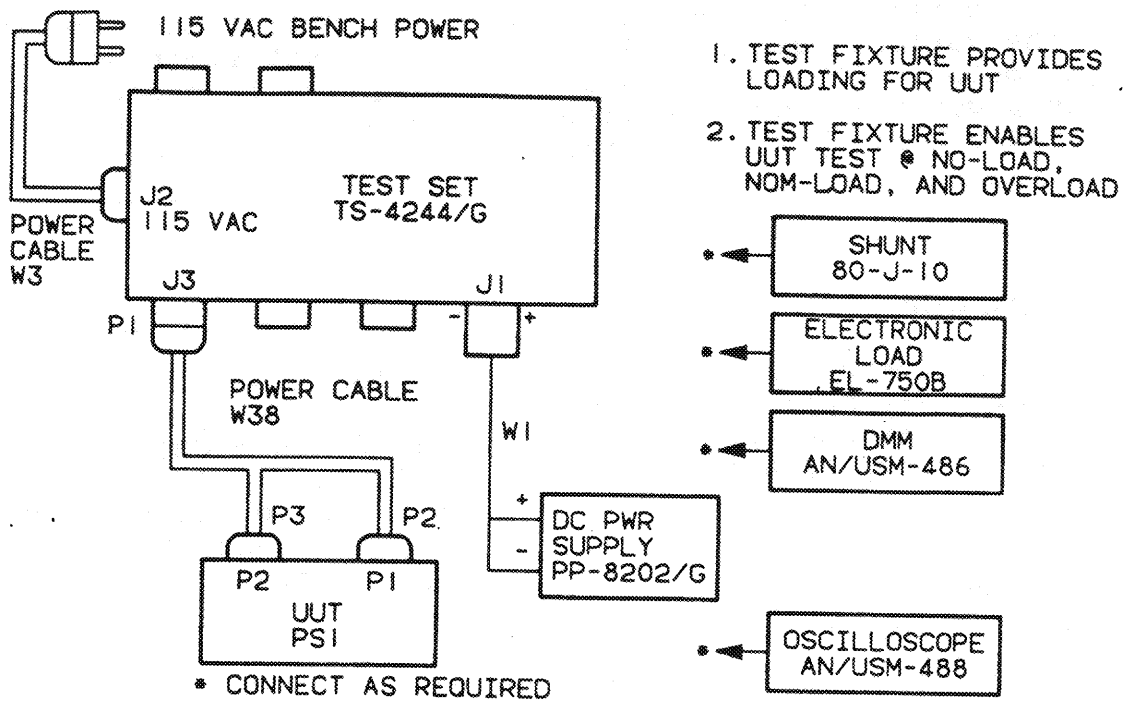

PS1 FUNCTIONAL TEST SET-UP

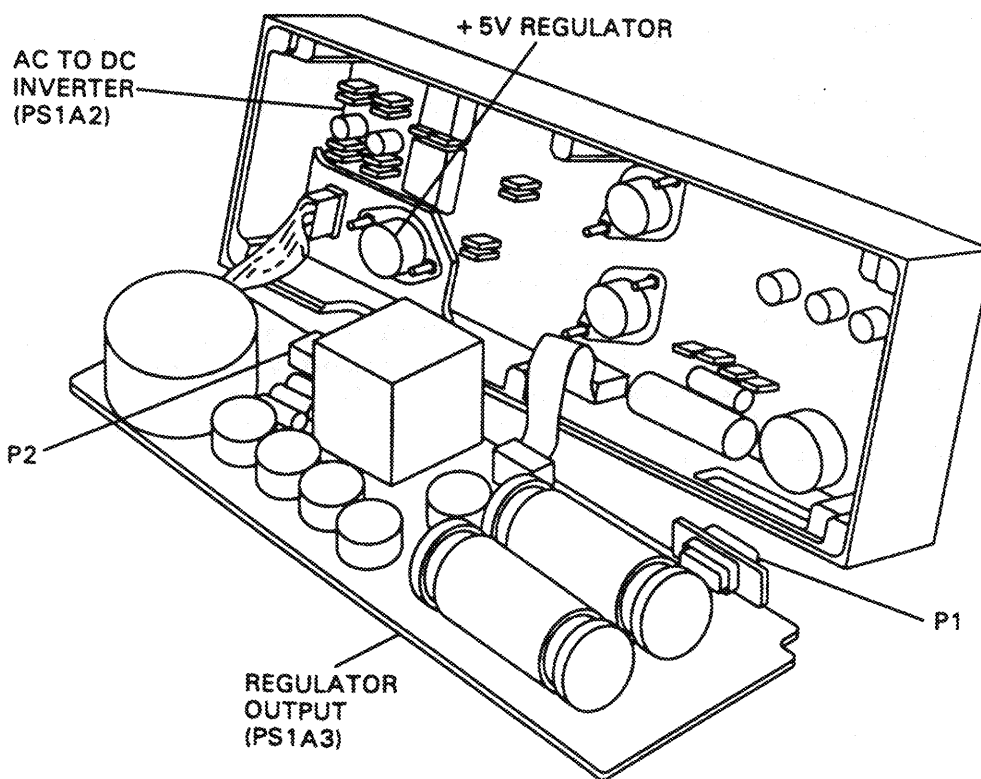

POWER SUPPLY DISASSEMBLED

3-10. POWER SUPPLY TROUBLESHOOTING (Cont.)

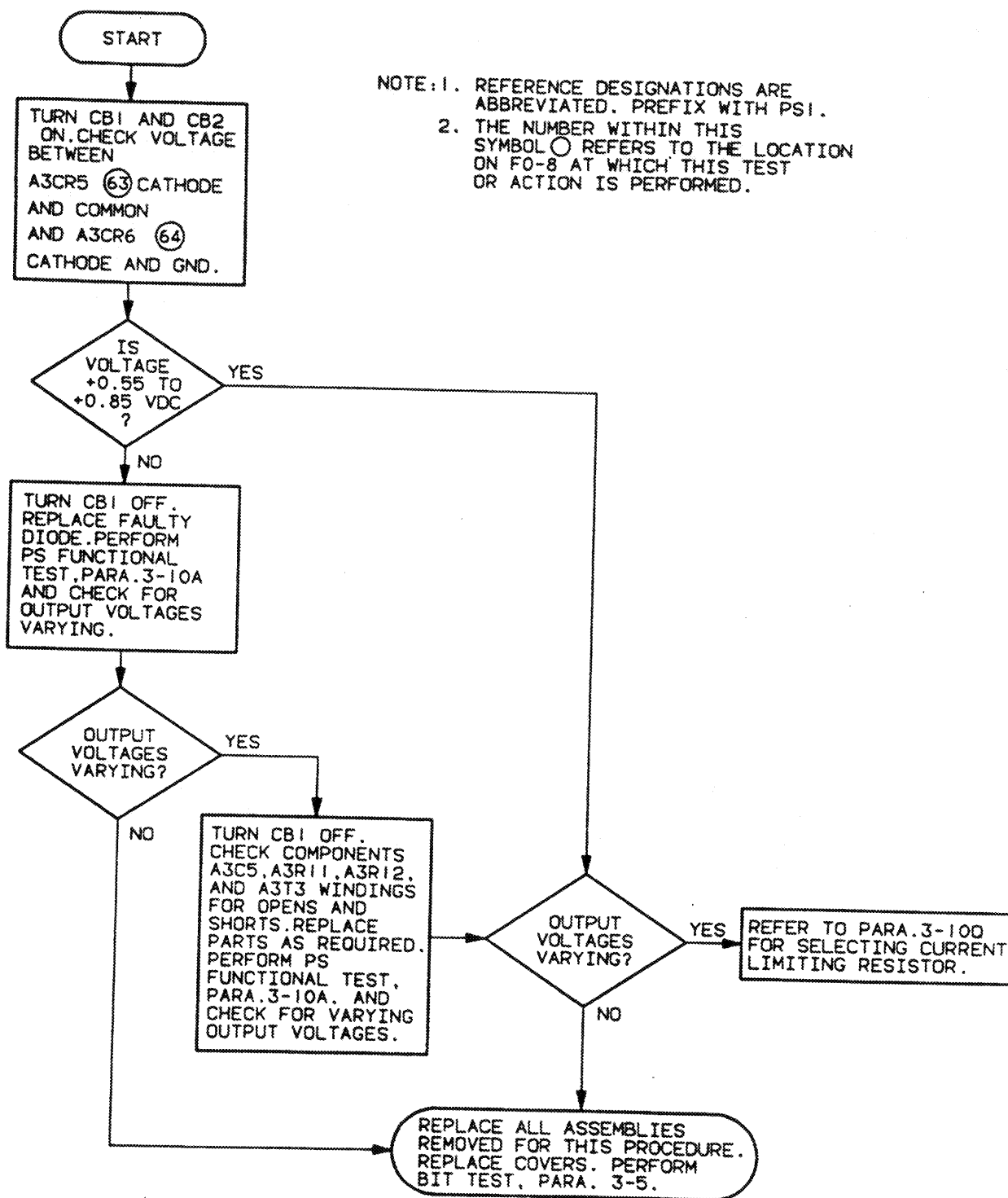

NOTE: 1. REFERENCE DESIGNATIONS ARE ABBREVIATED. PREFIX WITH PSI.
 2. THE NUMBER WITHIN THIS SYMBOL ○ REFERS TO THE LOCATION ON FO-8 AT WHICH THIS TEST OR ACTION IS PERFORMED.

3-10. POWER SUPPLY TROUBLESHOOTING (Cont.)

1. Selecting +12 V Current Limiting Resistor A3R14.

INITIAL SETUP

Test Equipment

Digital Multimeter AN/USM-486
Test Set, Power Supply TS-4244/G
Oscilloscope AN/USM-488
DC Power Supply, PP-8202/G

Tools

Tool Kit TK-17
Workstation, Static

Equipment Condition

PS1 functional test completed,
(para. 3-10)
Test fixture CB1 and CB2 OFF.
PS regulator output CCA removed
(para. 3-33) but reconnected
to ac to dc inverter
Test setup as illustrated.

WARNING

VOLTAGE is used in the operation of this equipment. DEATH ON CONTACT may result if personnel fail to observe safety precautions. Be careful not to contact high-voltage connections when testing this equipment.

CAUTION

This equipment contains components that are sensitive to damage by ESD. Improper handling will result in component and assembly failure. Use extreme caution when handling. Refer to DOD-HDBK-263 for proper handling procedures.

3-10. POWER SUPPLY TROUBLESHOOTING (Cont.)

- | | Values of
Available
Resistors
(ohms) |
|---|---|
| STEP 1. Is current limiting functioning above or below the value of 0.44 to 0.56 A? If above, go to step 5; if below, go to next step. | |
| STEP 2. Determine value of resistor A3R14 presently in circuit and, from list of resistors available, select resistor of next lower value. | 1.2k
1.3k
1.5k
1.6k
1.8k |
| STEP 3. Replace resistor in circuit with resistor just selected in step 2. | 2.0k
2.2k
2.4k
2.7k |
| STEP 4. Perform Overload test for +12 V supply and determine if current limiting is within 0.44 to 0.56 A limits or below the limits. If current limiting is below prescribed values, return to step 2. If current limiting is within prescribed values, test is complete. | 3.0k
3.9k
4.3k
5.1k
6.2k
7.5k
8.2k
10k |
| STEP 5. Determine value of resistor A3R14 presently in circuit and, from list of resistors available, select resistor of next higher value. | 12k
13k
15k
16k
18k
20k |
| STEP 6. Replace resistor in circuit with resistor just selected in step 5. | |
| STEP 7. Perform Overload test for +12 V supply and determine if current limiting is within 0.44 to 0.56 A limits or is above the limits. If current limiting is above the prescribed values, return to step 5. If current limiting is within prescribed values, test is complete. | |
| STEP 8. Replace all assemblies removed for this procedure. | |
| STEP 9. Perform PS functional test, (para. 3-10a). | |

3-10. POWER SUPPLY TROUBLESHOOTING (Cont.)

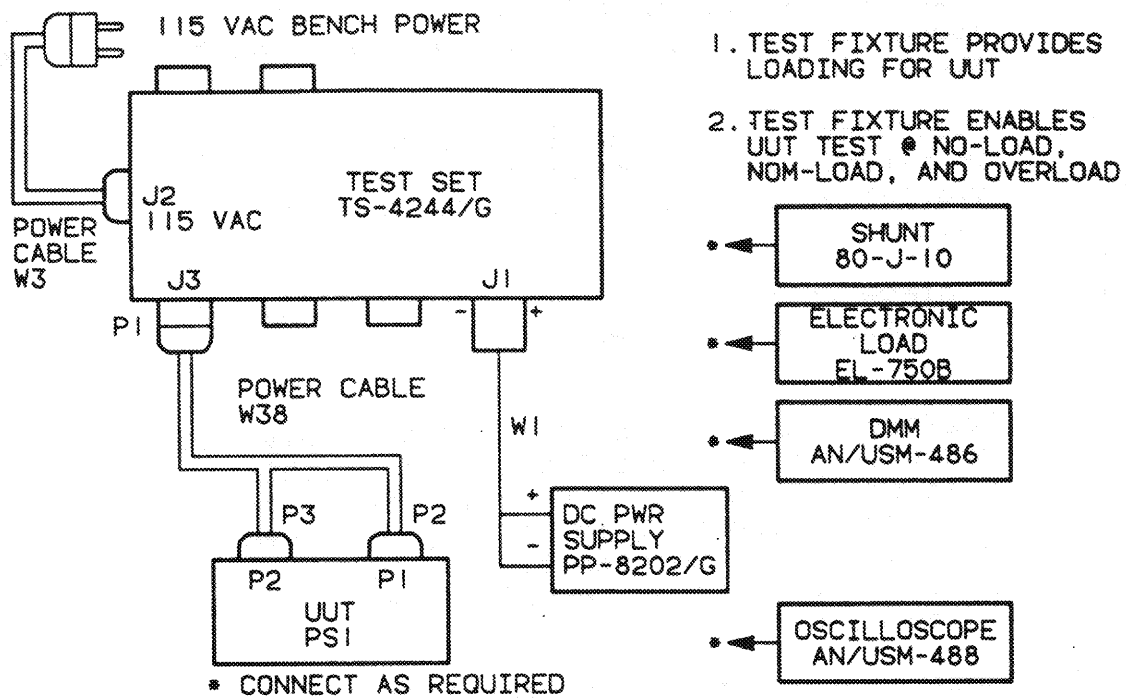

PS1 FUNCTIONAL TEST SET-UP

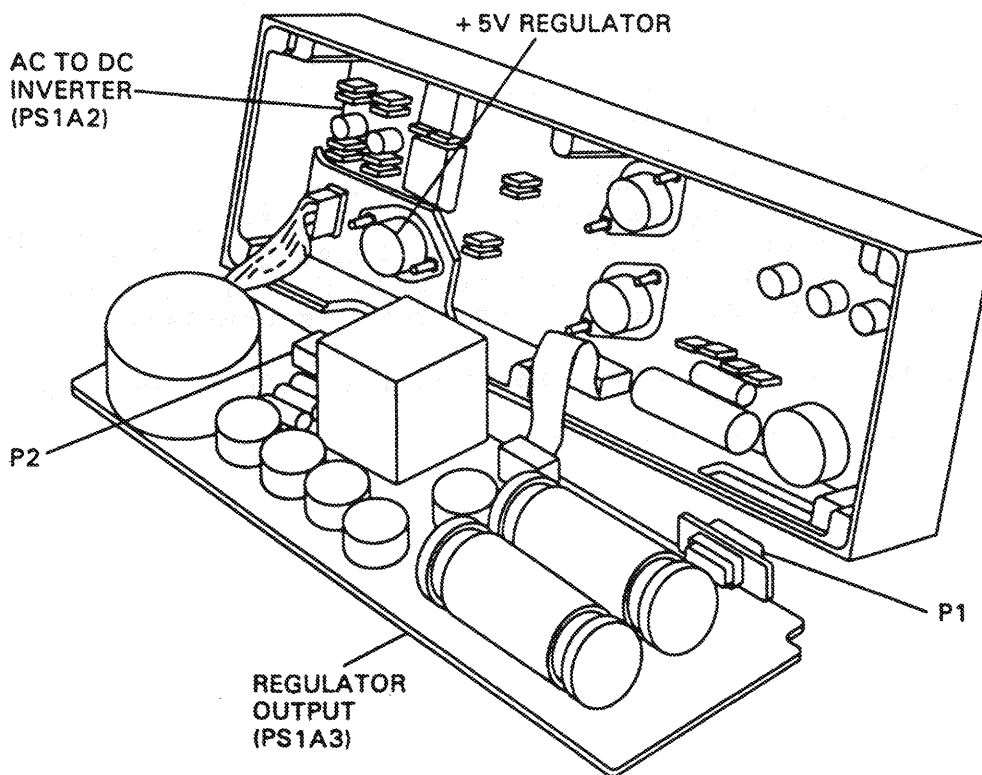

POWER SUPPLY DISASSEMBLED

3-10. POWER SUPPLY TROUBLESHOOTING (Cont.)

m. Selecting +28 V Current Limiting Resistor A3R20.

INITIAL SETUP

Test Equipment

Digital Multimeter AN/USM-486
Test Set, Power Supply TS-4244/G
Oscilloscope AN/USM-488
DC Power Supply, PP-8202/G

Equipment Condition

PS1 functional test completed,
(para. 3-10)
Test fixture CB1 and CB2 OFF.
PS regulator output CCA removed
(para. 3-33) but reconnected
to ac to dc inverter
Test setup as illustrated.

Tools

Tool Kit TK-17
Workstation, Static

WARNING

VOLTAGE is used in the operation of this equipment. DEATH ON CONTACT may result if personnel fail to observe safety precautions. Be careful not to contact high-voltage connections when testing this equipment.

CAUTION

This equipment contains components that are sensitive to damage by ESD. Improper handling will result in component and assembly failure. Use extreme caution when handling. Refer to DOD-HDBK-263 for proper handling procedures.

- STEP 1. Is current limiting functioning above or below the value of 1.32 to 1.68 A? If above, go to step 5; if below, go to next step.
- STEP 2. Determine value of resistor A3R20 presently in circuit and, from list of resistors available, select resistor of next lower value.
- STEP 3. Replace resistor in circuit with resistor just selected in step 2.

3-10. POWER SUPPLY TROUBLESHOOTING (Cont.)

- | | | |
|---------|---|---|
| STEP 4. | Perform Overload test for +28 V supply and determine if current limiting is within 1.32 to 1.68 A limits or below the limits. If current limiting is below prescribed values, return to step 2. If current limiting is within prescribed values, test is complete. | Values of Available Resistors (Ohms)
430
470
510 |
| STEP 5. | Determine value of resistor A3R20 presently in circuit and, from list of resistors available, select resistor of next higher value. | 560
620
680
750 |
| STEP 6. | Replace resistor in circuit with resistor just selected in step 5. | 820
910 |
| STEP 7. | Perform Overload test for +28 V supply and determine if current limiting is within 1.32 to 1.68 A limits or is above the limits. If current limiting is above the prescribed values, return to step 5. If current limiting is within prescribed values, test is complete. | |
| STEP 8. | Replace all assemblies removed for this procedure. | |
| STEP 9. | Perform PS functional test, (para. 3-10a). | |

3-10. POWER SUPPLY TROUBLESHOOTING (Cont.)

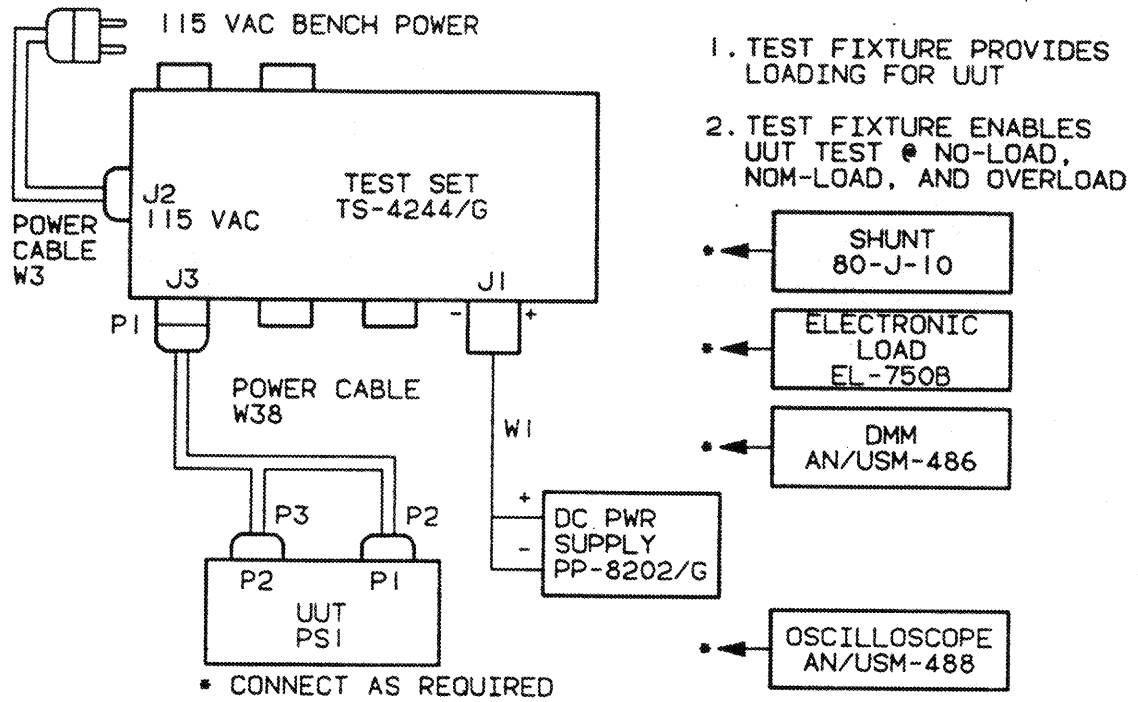

PS1 FUNCTIONAL TEST SET-UP

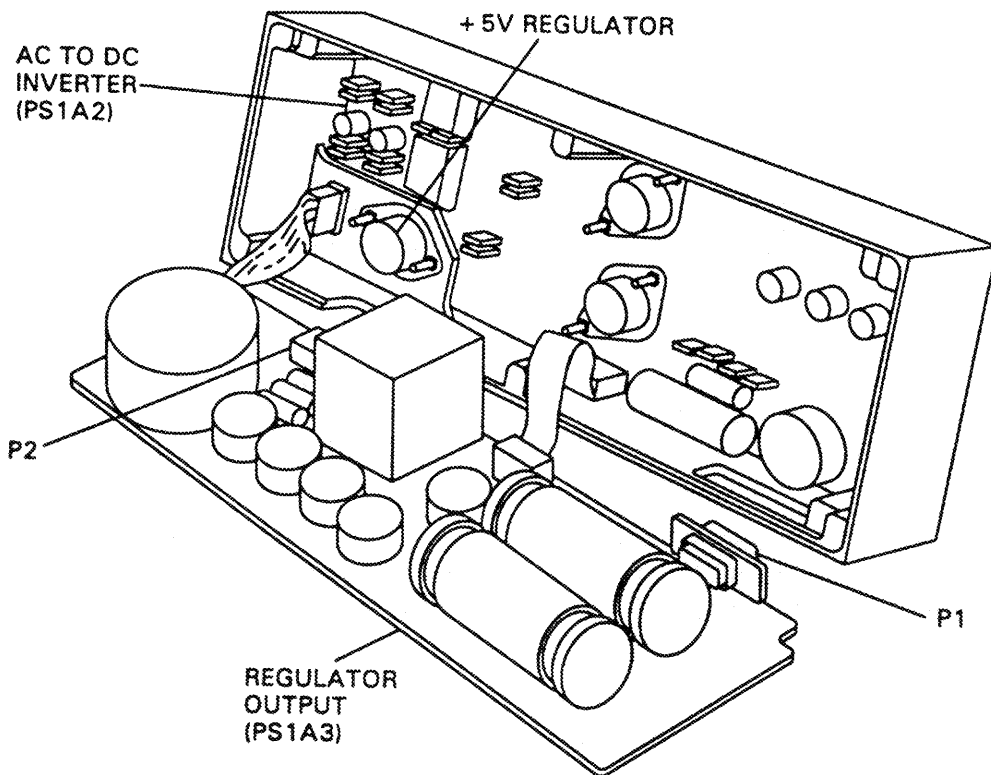

POWER SUPPLY DISASSEMBLED

3-10. POWER SUPPLY TROUBLESHOOTING (Cont.)

n. Selecting -12 V Current Limiting Resistor A3R16.

INITIAL SETUP

Test Equipment

Digital Multimeter AN/USM-486
 Test Set, Power Supply TS-4244/G
 Oscilloscope AN/USM-488
 DC Power Supply, PP-8202/G

Equipment Condition

PS1 functional test completed,
 (para. 3-10)
 Test fixture CB1 and CB2 OFF.
 PS regulator output CCA removed
 (para. 3-33) but reconnected
 to ac to dc inverter
 Test setup as illustrated.

Tools

Tool Kit TK-17
 Workstation, Static

WARNING

VOLTAGE is used in the operation of this equipment. DEATH ON CONTACT may result if personnel fail to observe safety precautions. Be careful not to contact high-voltage connections when testing this equipment.

CAUTION

This equipment contains components that are sensitive to damage by ESD. Improper handling will result in component and assembly failure. Use extreme caution when handling. Refer to DOD-HDBK-263 for proper handling procedures.

STEP 1.	Is current limiting functioning above or below the value of 0.22 to 0.28 A? If above, go to step 5; if below, go to next step.	Values of Available Resistors (ohms)
		3.3k
STEP 2.	Determine value of resistor A3R16 presently in circuit and, from list of resistors available, select resistor of next lower value.	3.6k
		3.9k
		4.3k
		4.7k
		5.1k
STEP 3.	Replace resistor in circuit with resistor just selected in step 2.	5.6k
		6.2k
		6.8k

3-10. POWER SUPPLY TROUBLESHOOTING (Cont.)

- STEP 4. Perform Overload test for -12 V supply and determine if current limiting is within 0.22 to 0.28 A limits or below the limits. If current limiting is below prescribed values, return to step 2. If current limiting is within prescribed values, test is complete.
- 7.5k
8.2k
9.1k
11k
12k
13k
15k
- STEP 5. Determine value of resistor A3R16 presently in circuit and, from list of resistors available, select resistor of next higher value.
- 16k
18k
20k
- STEP 6. Replace resistor in circuit with resistor just selected in step 5.
- STEP 7. Perform Overload test for -12 V supply and determine if current limiting is within 0.22 to 0.28 A limits or is above the limits. If current limiting is above the prescribed values, return to step 5. If current limiting is within prescribed values, test is complete.
- STEP 8. Replace all assemblies removed for this procedure.
- STEP 9. Perform PS function test, (para. 3-10a).

3-10. POWER SUPPLY TROUBLESHOOTING (Cont.)

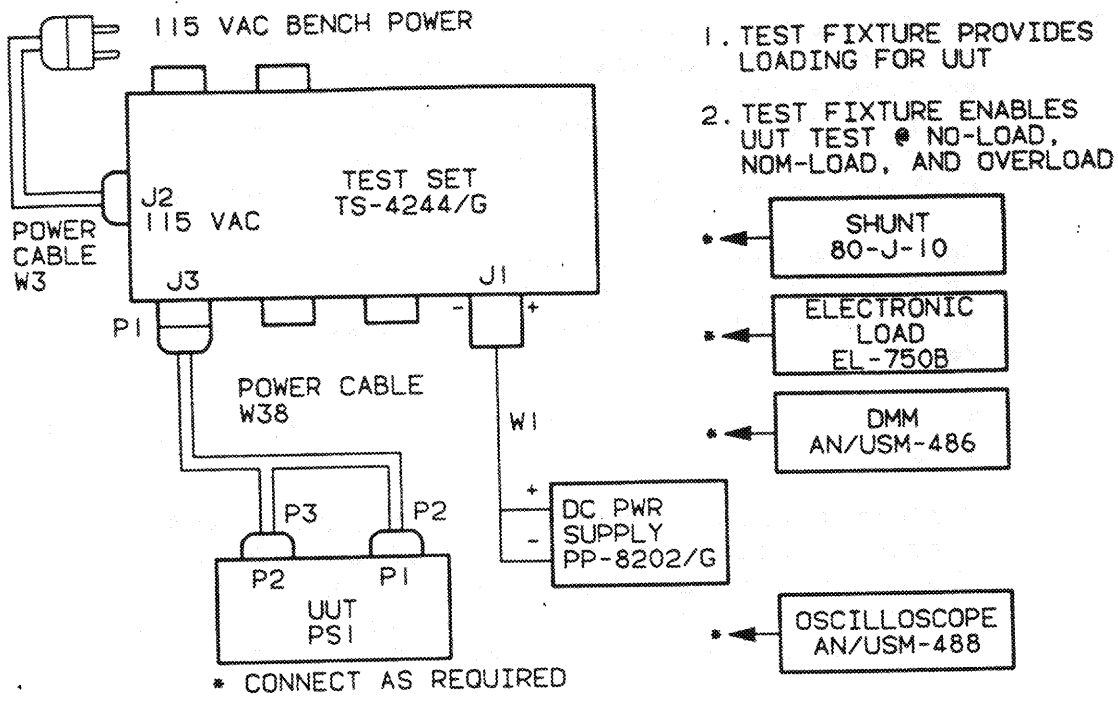

1. TEST FIXTURE PROVIDES LOADING FOR UUT
2. TEST FIXTURE ENABLES UUT TEST • NO-LOAD, NOM-LOAD, AND OVERLOAD

PS1 FUNCTIONAL TEST SET-UP

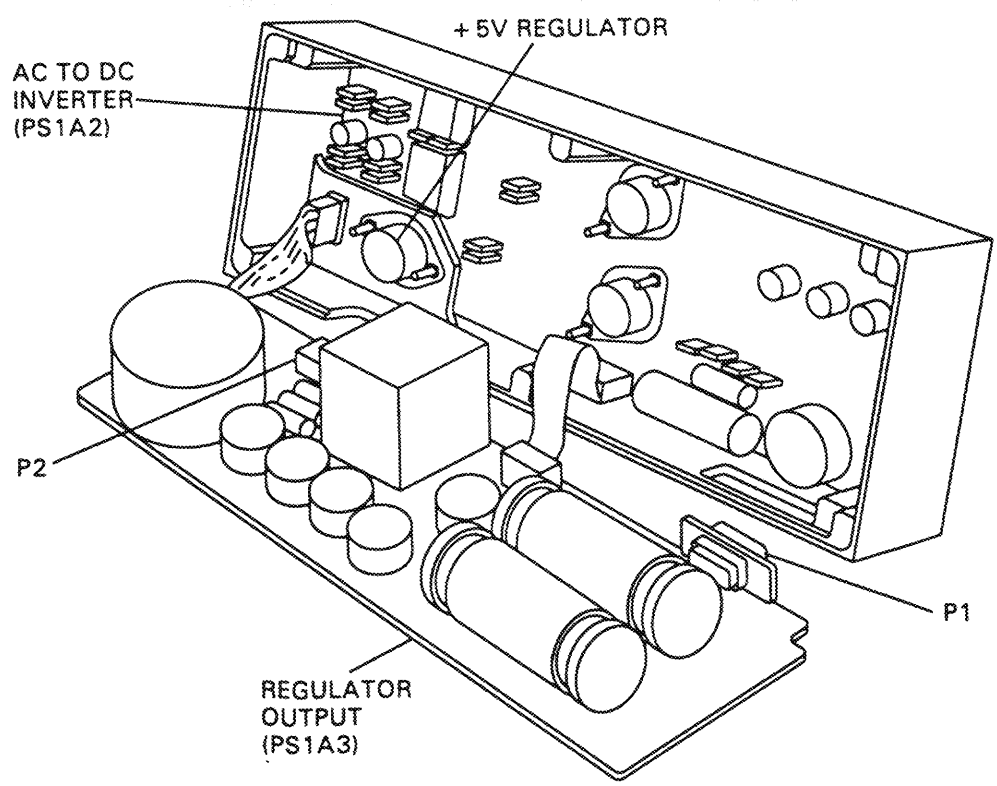

POWER SUPPLY DISASSEMBLED

3-10. POWER SUPPLY TROUBLESHOOTING (Cont.)

- o. Selecting +8.3 V Current Limiting Resistor A3R23.

INITIAL SETUP

Test Equipment

Digital Multimeter AN/USM-486
 Test Set, Power Supply TS-4244/G
 Oscilloscope AN/USM-488
 DC Power Supply, PP-8202/G

Equipment Condition

PS1 functional test completed,
 (para. 3-10)
 Test fixture CB1 and CB2 OFF.
 PS regulator output CCA removed
 (para. 3-33) but reconnected
 to ac to dc inverter
 Test setup as illustrated on page
 3-63.

Tools

Tool Kit TK-17
 Workstation, Static

WARNING

VOLTAGE is used in the operation of this equipment. DEATH ON CONTACT may result if personnel fail to observe safety precautions. Be careful not to contact high-voltage connections when testing this equipment.

CAUTION

This equipment contains components that are sensitive to damage by ESD. Improper handling will result in component and assembly failure. Use extreme caution when handling. Refer to DOD-HDBK-263 for proper handling procedures.

- | | | |
|---------|--|--|
| STEP 1. | Is current limiting functioning above or below the value of 3.3 to 4.1 A? If above, go to step 5; if below, go to next step. | Values of Available Resistors (ohms) |
| STEP 2. | Determine value of resistor A3R23 presently in circuit and, from list of resistors available, select resistor of next lower value. | 180
200
220
240
270
330 |
| STEP 3. | Replace resistor in circuit with resistor just selected in step 2. | 360
390 |

3-10. POWER SUPPLY TROUBLESHOOTING (Cont.)

- STEP 4. Perform Overload test for +8.3 V supply and determine if current limiting is within 3.3 to 4.1 A limits or below the limits. If current limiting is below prescribed values, return to step 2. If current limiting is within prescribed values, test is complete.
- STEP 5. Determine value of resistor A3R23 presently in circuit and, from list of resistors available, select resistor of next higher value.
- STEP 6. Replace resistor in circuit with resistor just selected in step 5.
- STEP 7. Perform Overload test for +8.3 V supply and determine if current limiting is within 3.3 to 4.1 A limits or is above the limits. If current limiting is above the prescribed values, return to step 5. If current limiting is within prescribed values, test is complete.
- STEP 8. Replace all assemblies removed for this procedure.
- STEP 9. Perform PS functional test, (para. 3-10a).

3-10. POWER SUPPLY TROUBLESHOOTING (Cont.)

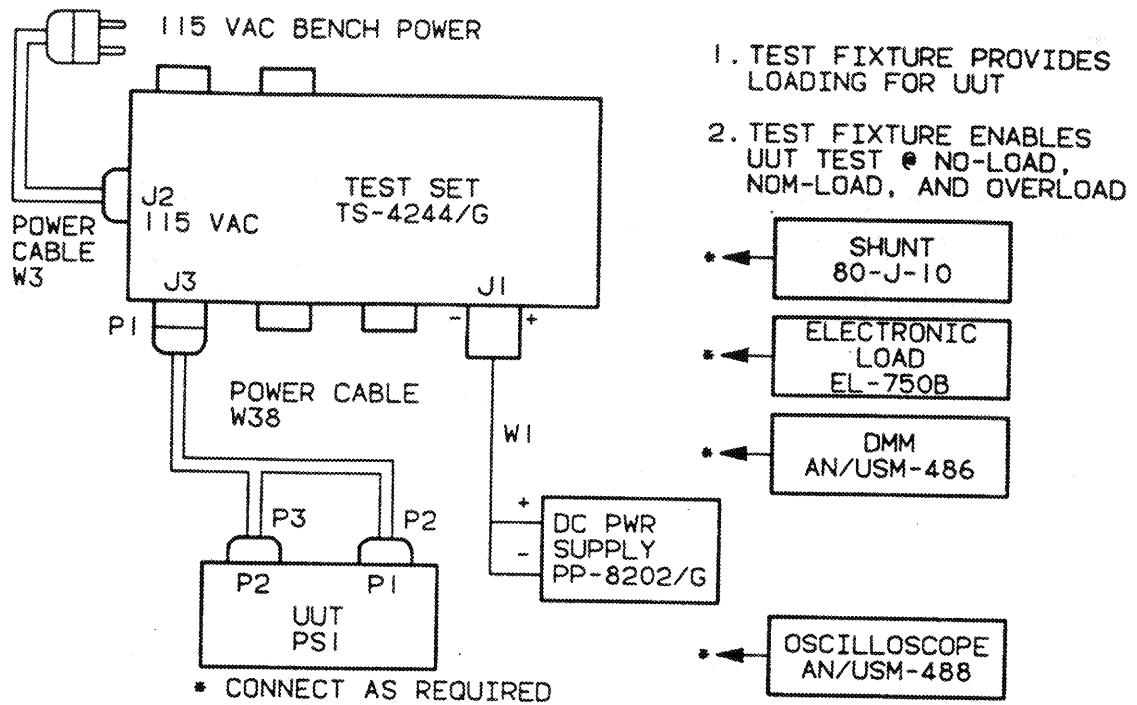

PS1 FUNCTIONAL TEST SET-UP

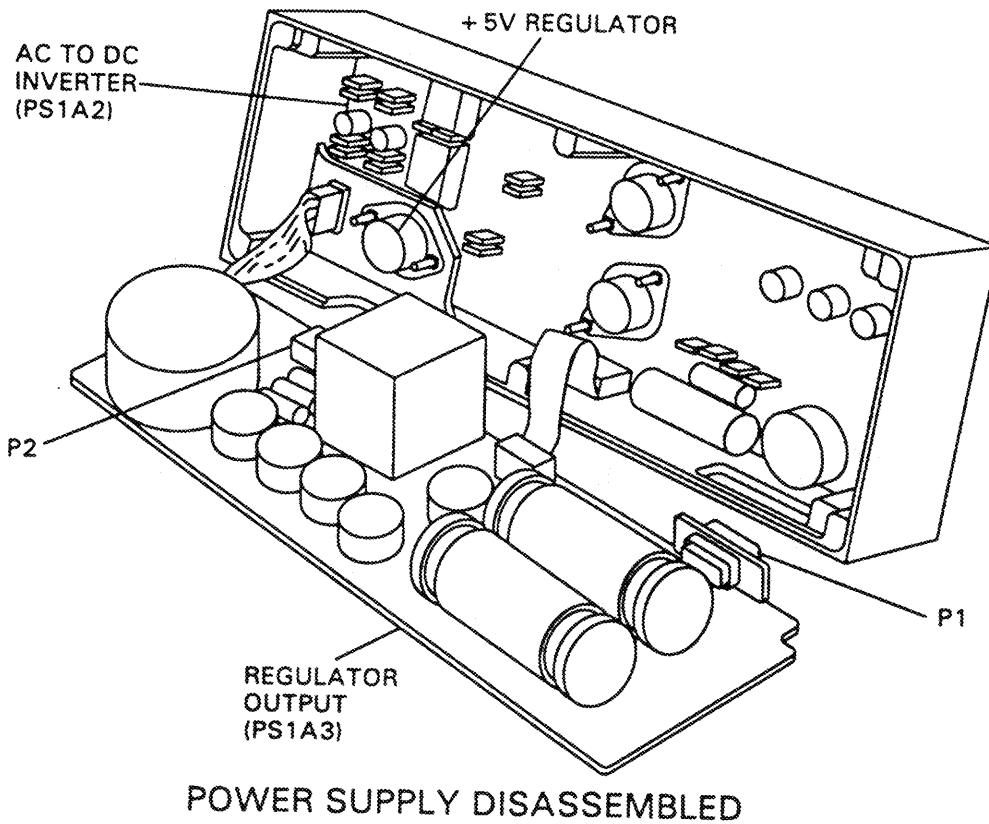

3-10. POWER SUPPLY TROUBLESHOOTING (Cont.)

p. Selecting +5 V Regulating Resistor A2R56.

INITIAL SETUP

Test Equipment

Digital Multimeter AN/USM-486
 Test Set, Power Supply TS-4244/G
 Oscilloscope AN/USM-488
 DC Power Supply, PP-8202/G

Tools

Tool Kit TK-17
 Workstation, Static

Equipment Condition

PS1 functional test completed,
 (para. 3-10)
 Test fixture CB1 and CB2 OFF.
 PS regulator output CCA removed
 (para. 3-33) but reconnected
 to ac to dc inverter
 Test setup as illustrated on page
 3-66.

WARNING

VOLTAGE is used in the operation of this equipment. DEATH ON CONTACT may result if personnel fail to observe safety precautions. Be careful not to contact high-voltage connections when testing this equipment.

CAUTION

This equipment contains components that are sensitive to damage by ESD. Improper handling will result in component and assembly failure. Use extreme caution when handling. Refer to DOD-HDBK-263 for proper handling procedures.

- | | |
|--|--|
| <p>STEP 1. Is the load voltage of the +5 V supply below or above the value of +4.75 to +5.25 V? If above, go to step 5; if below, go to the next step.</p> <p>STEP 2. Determine value of resistor A2R56 presently in circuit and, from list of resistors available, select resistor of next lower value.</p> <p>STEP 3. Replace resistor in circuit with resistor just selected in step 2.</p> | <p>Values of Available Resistors (ohms)</p> <p>33k
 36k
 39k
 43k
 47k
 51k
 56k</p> |
|--|--|

3-10. POWER SUPPLY TROUBLESHOOTING (Cont.)

- STEP 4. Perform Load test for +5 V supply and determine if voltage is within +4.75 to +5.25 V limits or below the limits. If voltage is below prescribed values, return to step 2. If voltage is within prescribed values, test is complete.
- STEP 5. Determine value of resistor A2R56 presently in circuit and, from list of resistors available, select resistor of next higher value.
- STEP 6. Replace resistor in circuit with resistor just selected in step 5.
- STEP 7. Perform Load test for +5 V supply and determine if voltage is within +4.75 to +5.25 V limits or above the limits. If voltage is above prescribed limits, go to step 5. If voltage is within prescribed limits, test is complete.
- STEP 8. Replace all assemblies removed for this procedure.
- STEP 9. Perform PS functional test (para. 3-10a).

3-10. POWER SUPPLY TROUBLESHOOTING (Cont.)

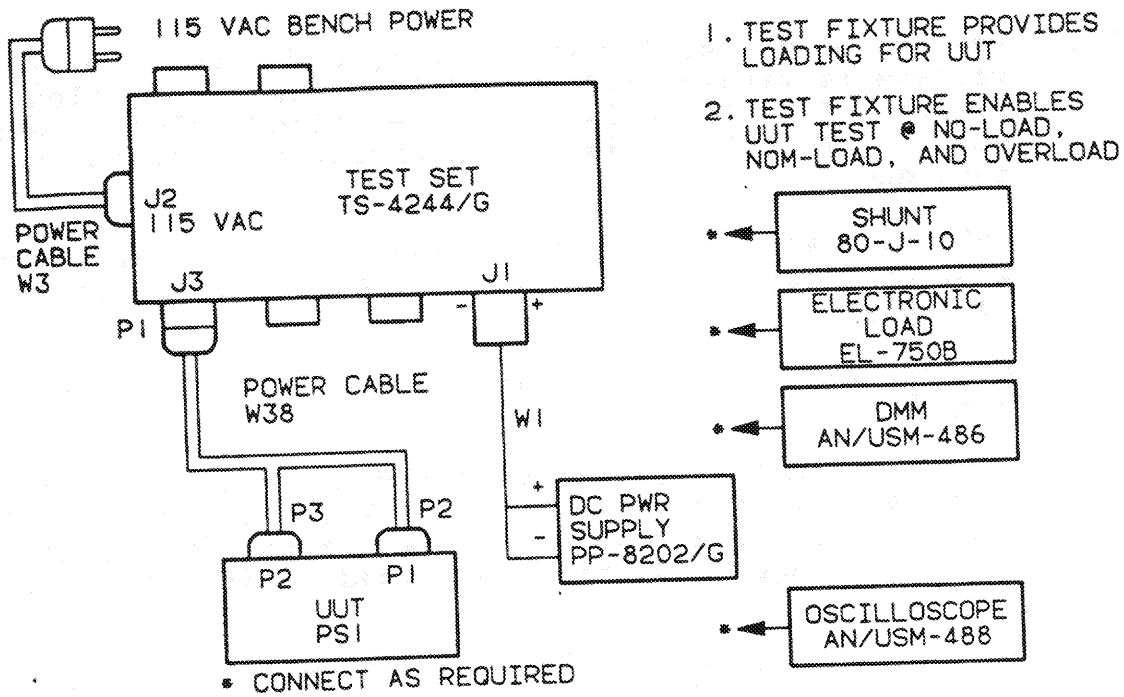

PS1 FUNCTIONAL TEST SET-UP

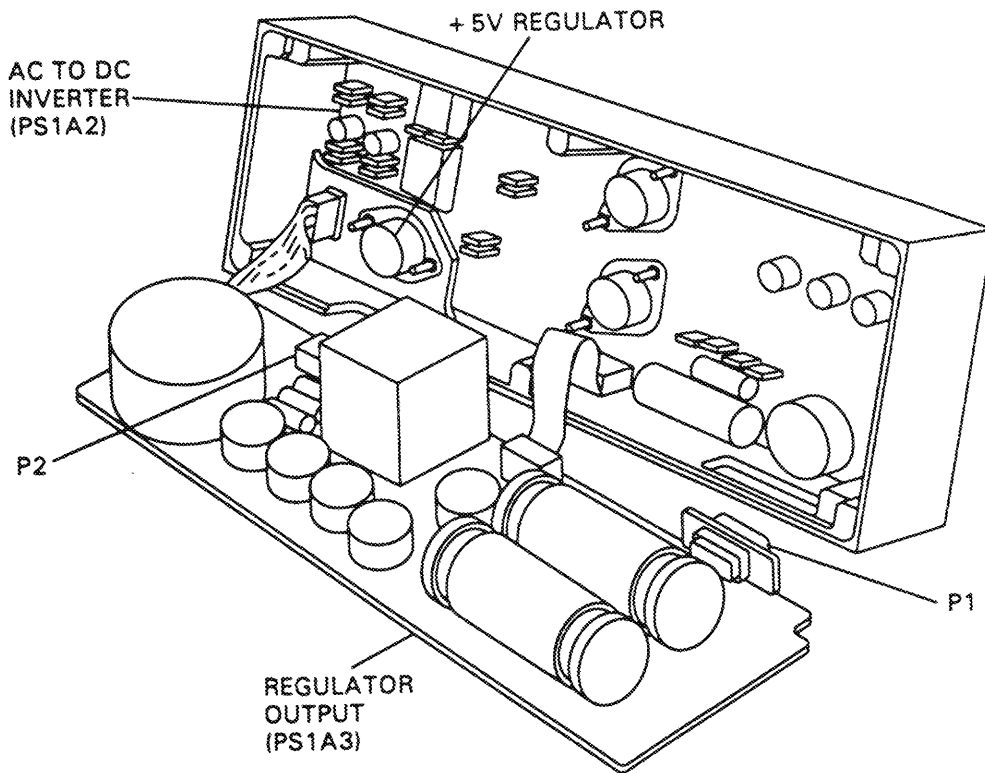

POWER SUPPLY DISASSEMBLED

3-10. POWER SUPPLY TROUBLESHOOTING (Cont.)

q. Selecting Power Transformer Current Limiting Resistor A3R12.

INITIAL SETUP

Test Equipment

Digital Multimeter AN/USM-486
 Test Set, Power Supply TS-4244/G
 Oscilloscope AN/USM-488
 DC Power Supply, PP-8202/G

Equipment Condition

PS1 functional test completed,
 (para. 3-10)
 Test fixture CB1 and CB2 OFF.
 PS regulator output CCA removed
 (para. 3-33) but reconnected
 to ac to dc inverter
 Test setup as illustrated on page
 3-69.

Tools

Tool Kit TK-17
 Workstation, Static

WARNING

VOLTAGE is used in the operation of this equipment. DEATH ON CONTACT may result if personnel fail to observe safety precautions. Be careful not to contact high-voltage connections when testing this equipment.

CAUTION

This equipment contains components that are sensitive to damage by ESD. Improper handling will result in component and assembly failure. Use extreme caution when handling. Refer to DOD-HDBK-263 for proper handling procedures.

- | | |
|---|---|
| <p>STEP 1. Determine value of resistor A3R12 presently in circuit and, from list of available resistors, select resistor of same value.</p> | <p>Values of Available Resistors (ohms)</p> |
| <p>STEP 2. Replace resistor in circuit with resistor just selected.</p> | <p>910
1.0k
1.1k
1.2k</p> |
| <p>STEP 3. Connect oscilloscope to A2U3-13 (37). Position S1 to LOAD, CB1 to ON and CB2 to ON.</p> | <p>1.3k
1.5k
1.6k</p> |

3-10. POWER SUPPLY TROUBLESHOOTING (Cont.)

- STEP 4. Observe voltage pattern on oscilloscope for varying voltage or steady voltage. If voltage is steady, go to step 6. If voltage is varying, go to next step.
- STEP 5. Determine value of resistor A3R12 presently in circuit. From list of resistors available, select resistor of next lower value. Turn CBI OFF and go to step 2.
- STEP 6. Did the previously installed resistor before the present resistor in the circuit cause the voltage at A2U3-13 to be varying? If it did, test is complete. If it did not cause varying voltage, or this is the first resistor tested, determine value of present resistor A3R12 in circuit. Select a resistor of next higher value from list of available resistors. Turn CBI OFF and go to step 2.
- STEP 7. Replace all assemblies removed for this procedure.
- STEP 8. Perform PS functional test (para. 3-10a).

3-10. POWER SUPPLY TROUBLESHOOTING (Cont.)

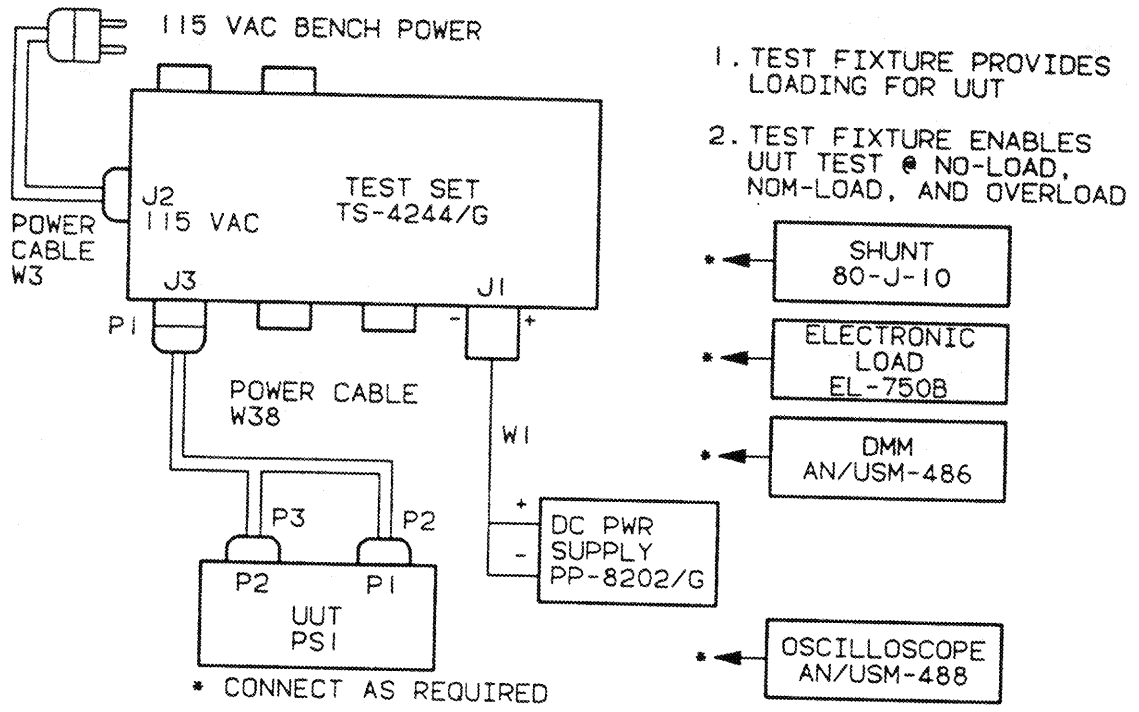

PS1 FUNCTIONAL TEST SET-UP

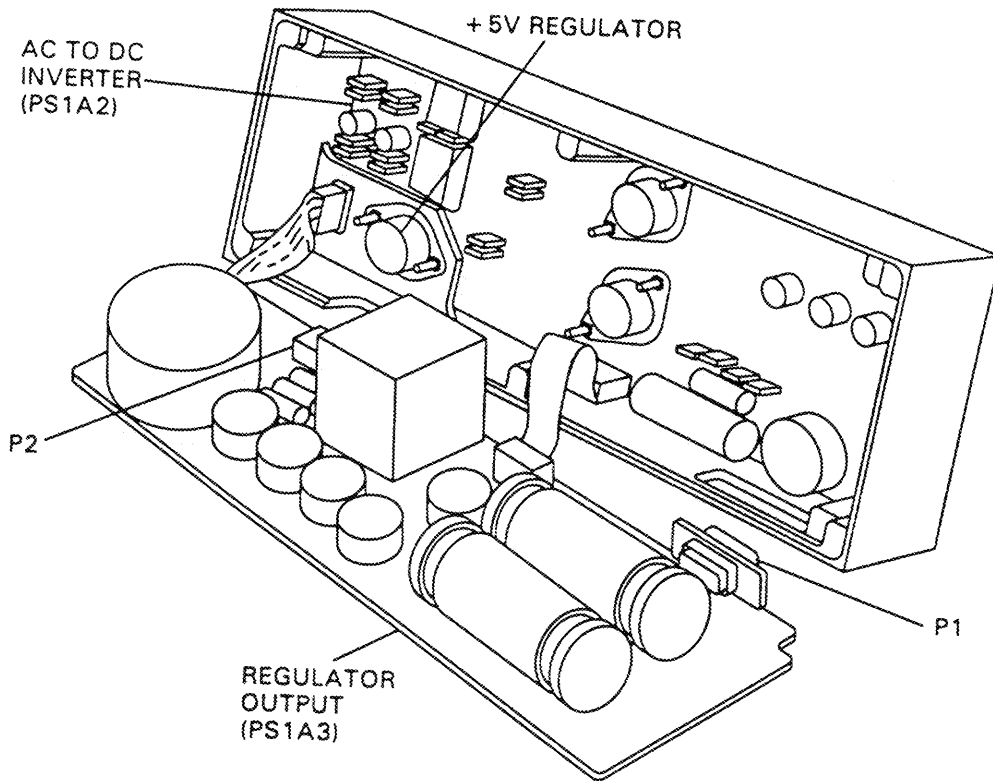

POWER SUPPLY DISASSEMBLED

3-10. POWER SUPPLY TROUBLESHOOTING (Cont.)

r. Troubleshooting the Complete Power Supply. This procedure is to be used when there is no output voltage from the power supply or when procedures of paragraph 3-10b through 3-10g do not solve the problem. For TP callouts on troubleshooting flow charts refer to figures FO-5, FO-6, FO-8, and FO-9.

INITIAL SETUP

Test Equipment

Digital Multimeter AN/USM-486
 Test Set, Power Supply TS-4244/G
 Oscilloscope AN/USM-488
 DC Power Supply, PP-8202/G

Equipment Condition

PS1 functional test completed,
 (para. 3-10)
 Power removed
 PS regulator output CCA removed
 (para. 3-33) but reconnected
 to ac to dc inverter
 Test fixture CB1 and CB2 ON,
 S1 set to LOAD.

Tools

Tool Kit TK-17
 Repair Kit, PCB MK-772/U
 Maintenance Kit, PCB MX-10897/G
 Workstation, Static

WARNING

VOLTAGE is used in the operation of this equipment. DEATH ON CONTACT may result if personnel fail to observe safety precautions. Be careful not to contact high-voltage connections when testing this equipment.

CAUTION

This equipment contains components that are sensitive to damage by ESD. Improper handling will result in component and assembly failure. Use extreme caution when handling. Refer to DOD-HDBK-263 for proper handling procedures.

3-10. POWER SUPPLY TROUBLESHOOTING (Cont.)

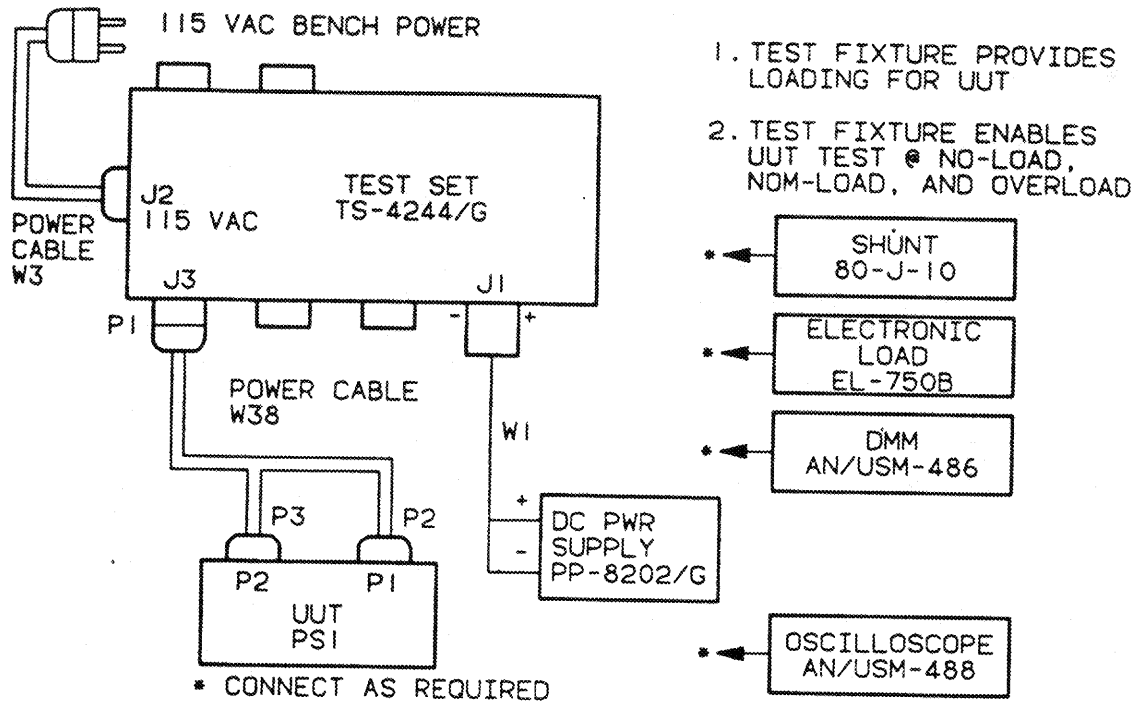

PS1 FUNCTIONAL TEST SET-UP

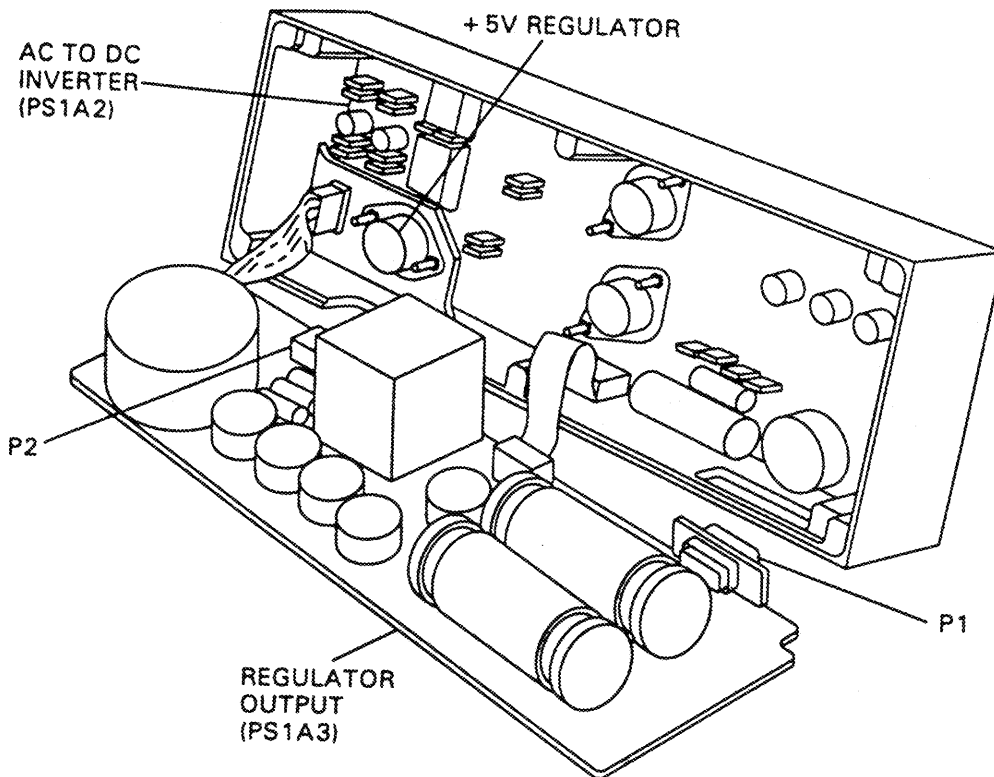

POWER SUPPLY DISASSEMBLED

3-10. POWER SUPPLY TROUBLESHOOTING (Cont.)

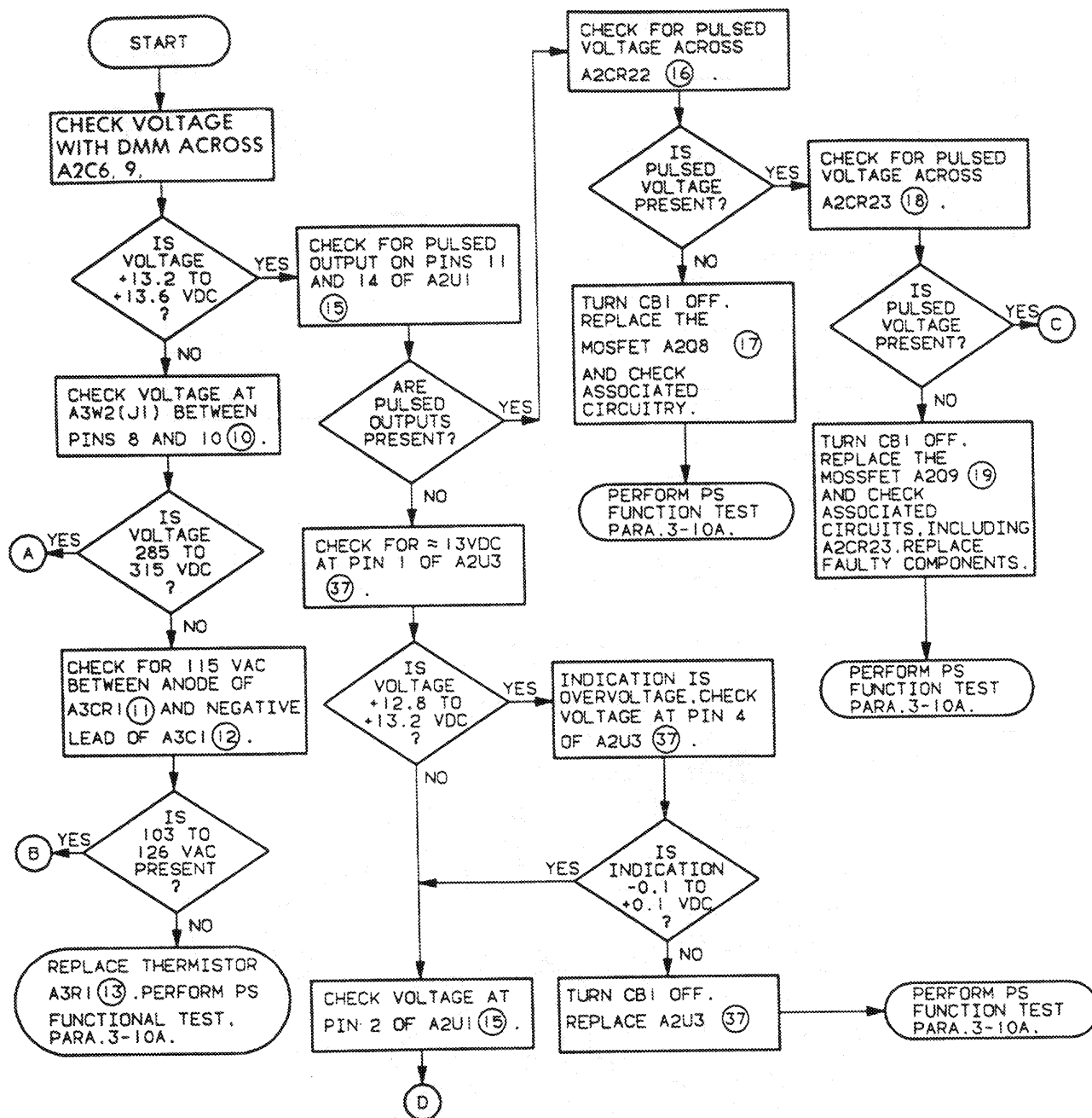

NOTE: 1. REFERENCE DESIGNATIONS ARE ABBREVIATED. PREFIX WITH PSI.
 2. THE NUMBER WITHIN THIS SYMBOL ○ REFERS TO THE LOCATION AT WHICH THIS TEST OR ACTION IS PERFORMED. REFERENCE DESIGNATION A3 REFERS TO F0-8. REFERENCE DESIGNATION A2 REFERS TO F0-9.

3-10. POWER SUPPLY TROUBLESHOOTING (Cont.)

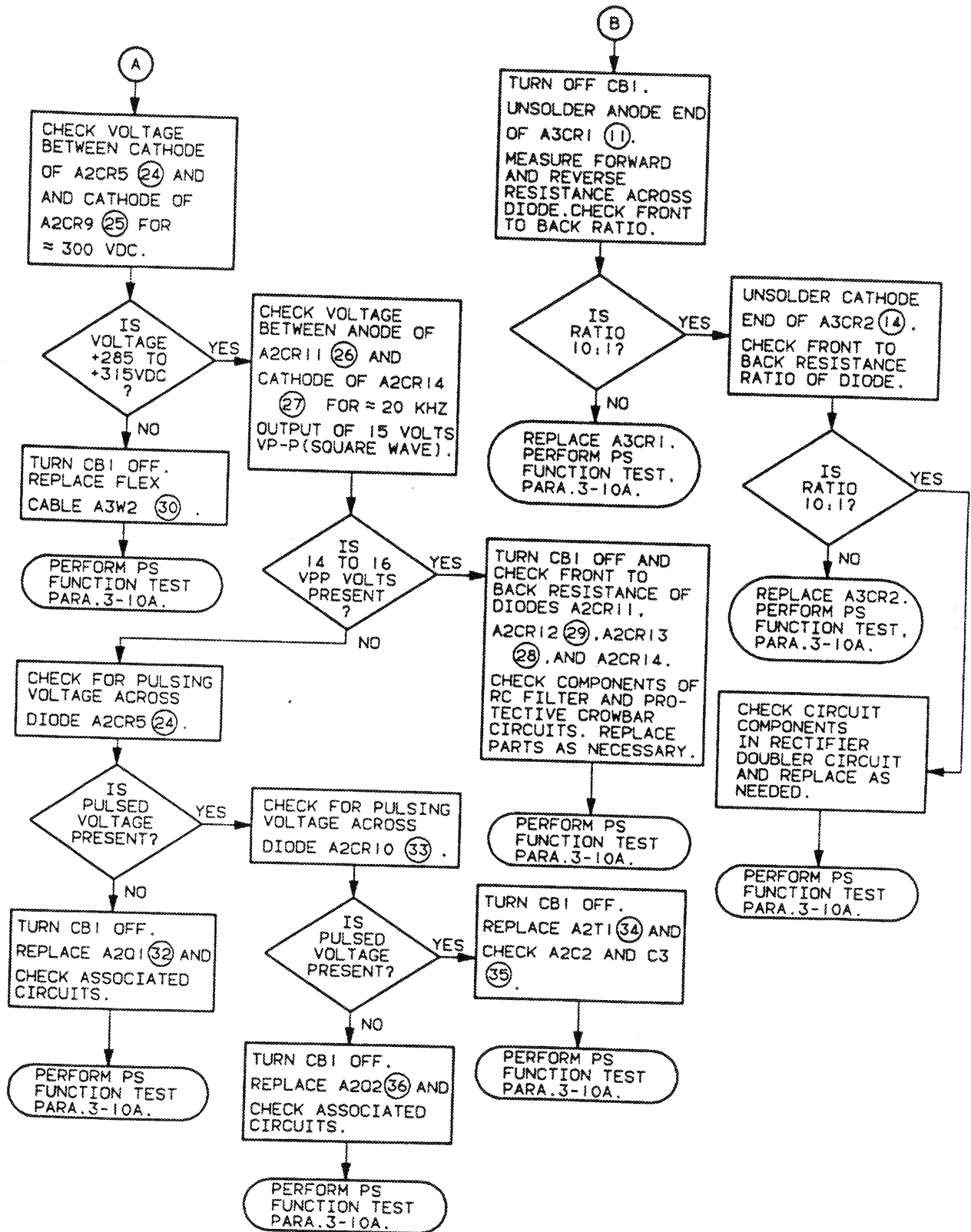

3-10. POWER SUPPLY TROUBLESHOOTING (Cont.)

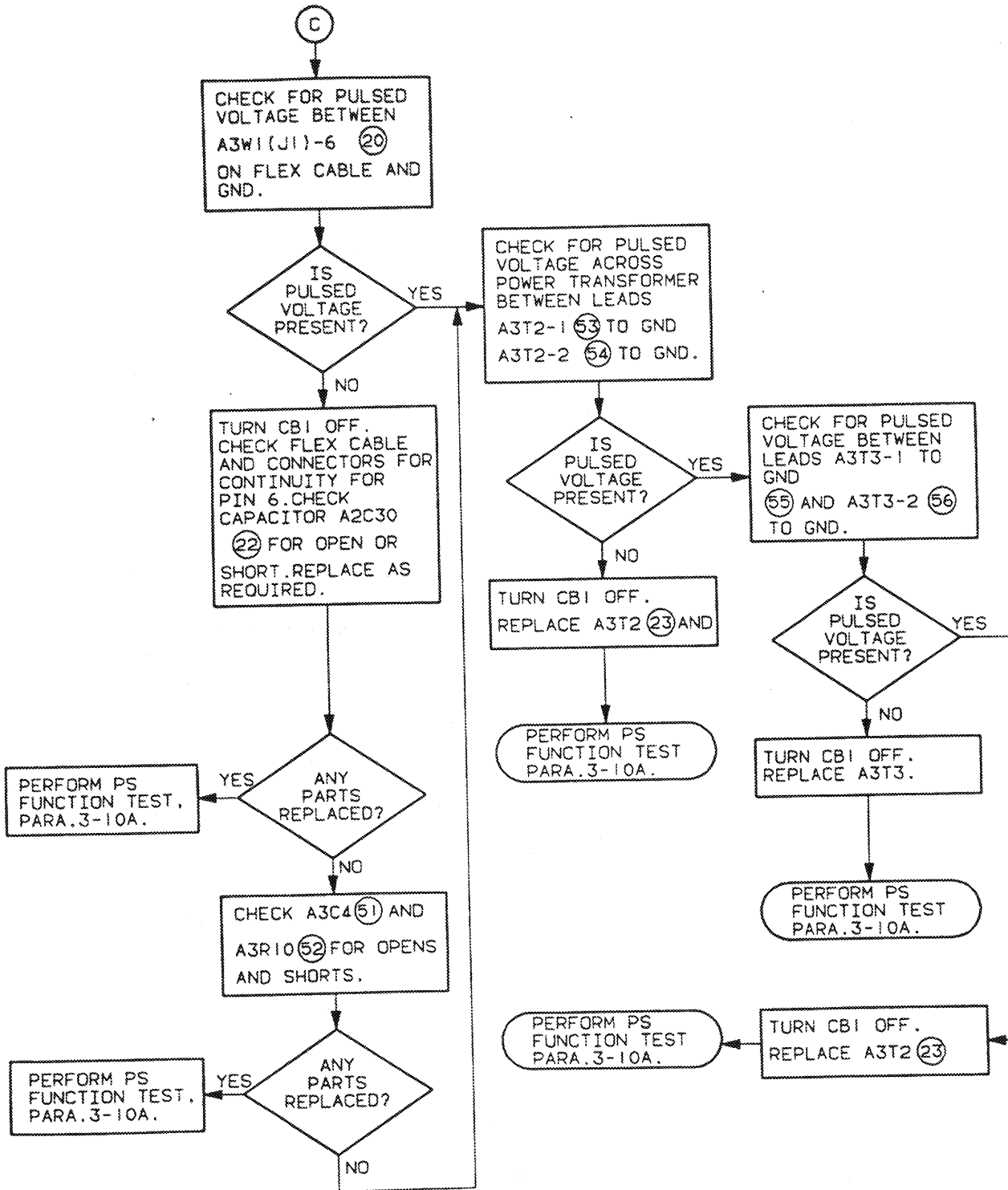

3-10. POWER SUPPLY TROUBLESHOOTING (Cont.)

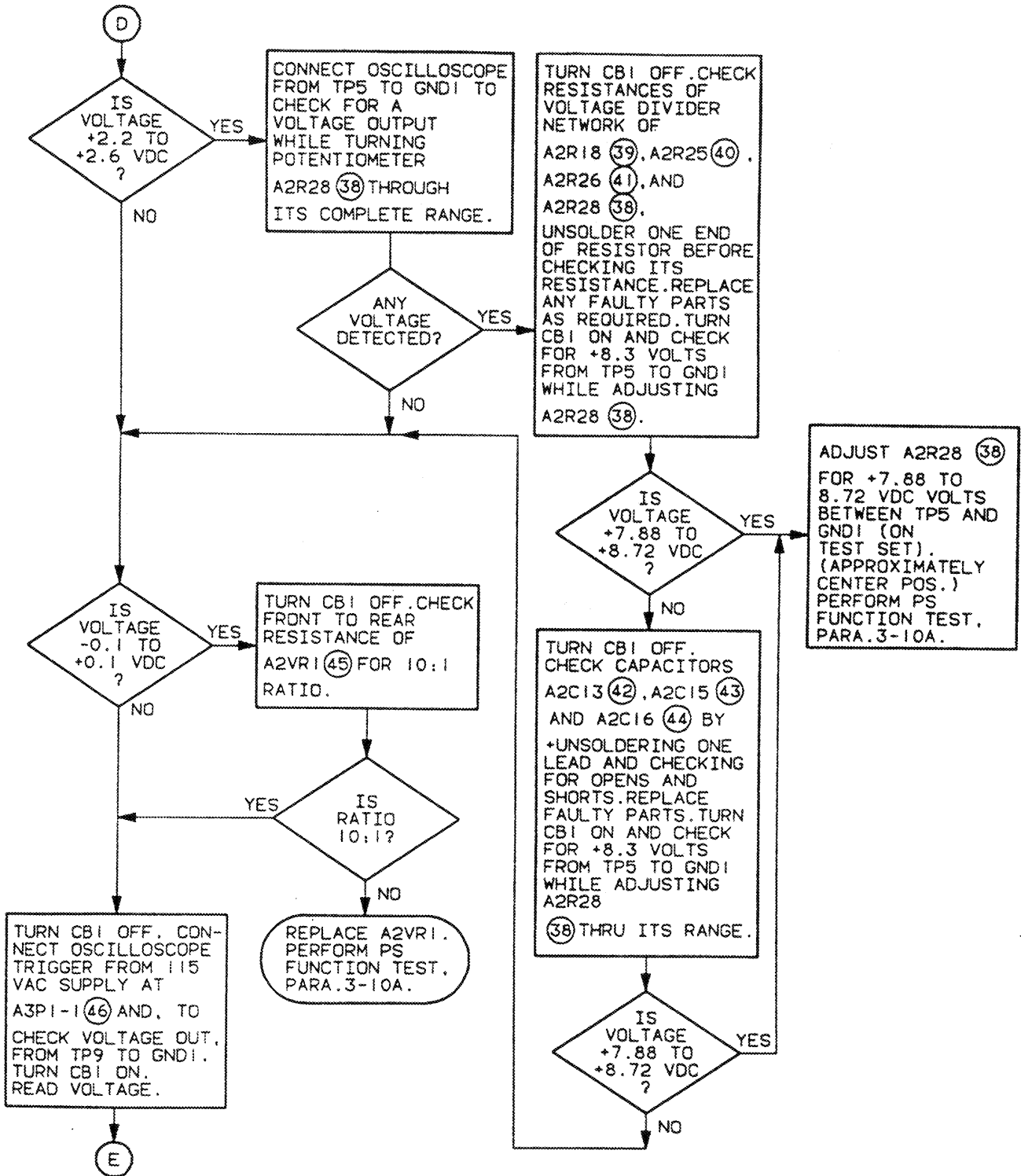

3-10. POWER SUPPLY TROUBLESHOOTING (Cont.)

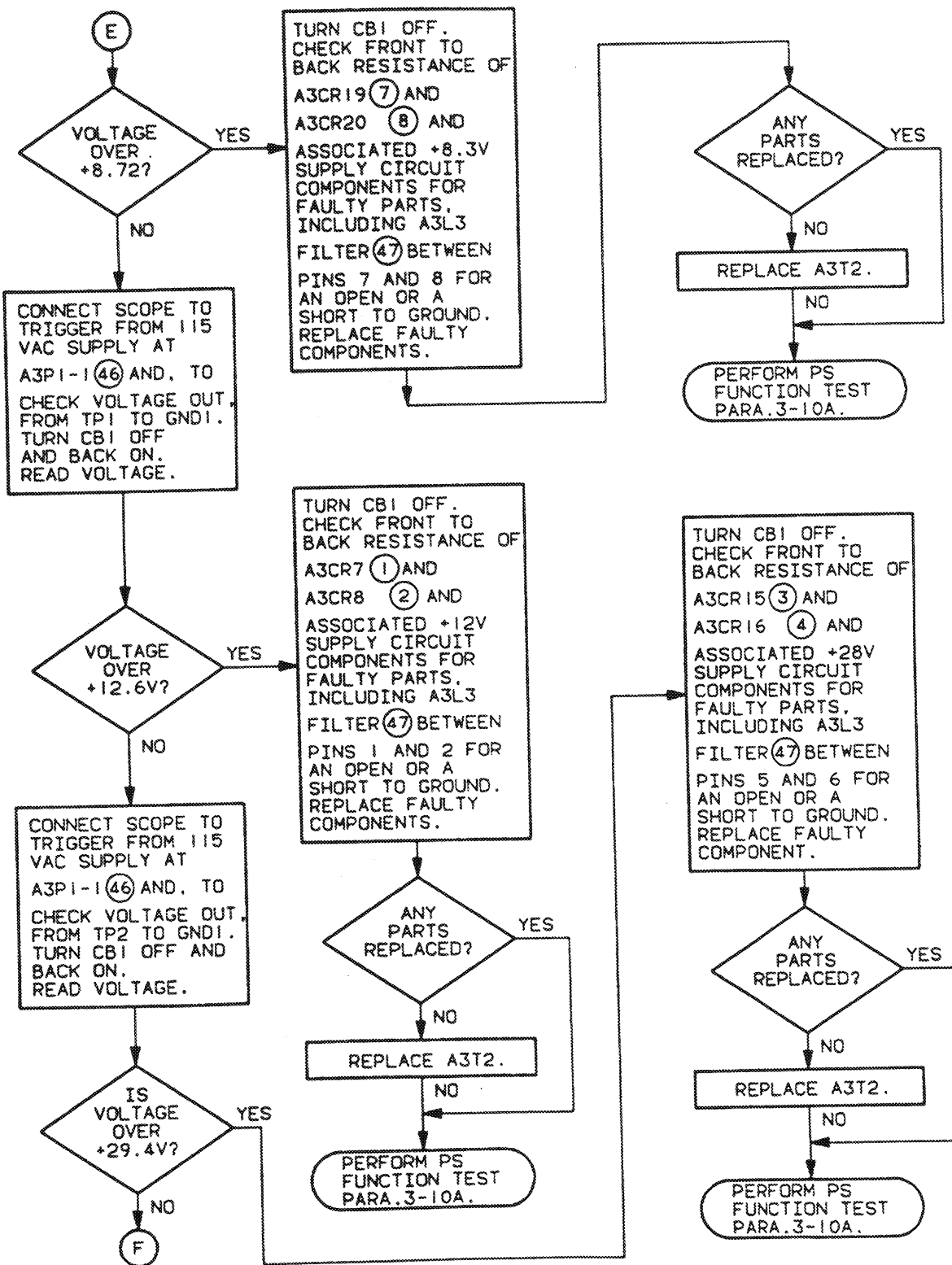

3-10. POWER SUPPLY TROUBLESHOOTING (Cont.)

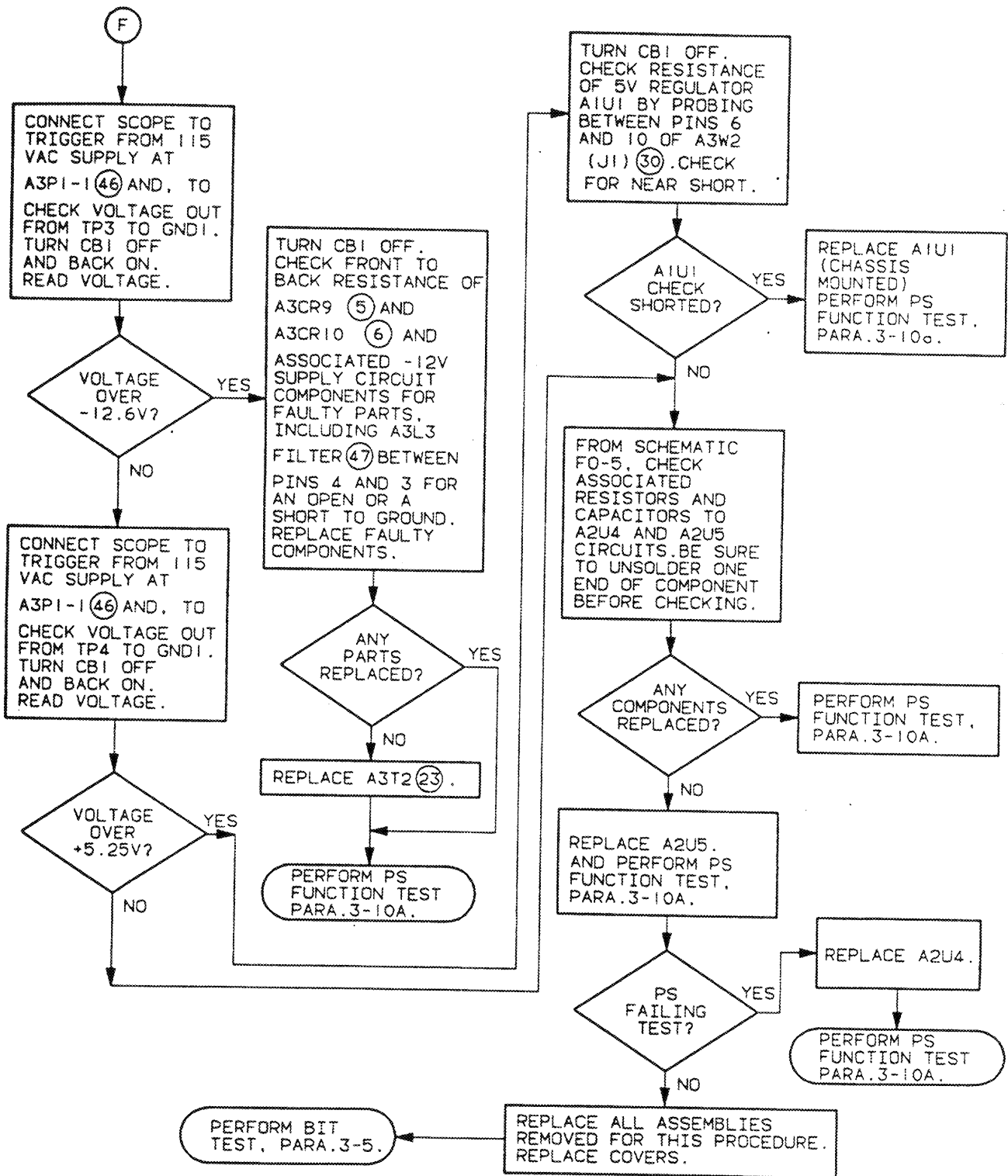

Section III. INTERMEDIATE GENERAL SUPPORT MAINTENANCE

3-11. GENERAL

Maintenance at the Intermediate General Support level is limited to replacement of defective modules, chassis assemblies, components, and shielding strips.

Upon completion of replacement action, BIT shall be performed to ensure proper operation of the replaced component and its related system.

WARNING

HIGH VOLTAGE is used in the operation of this equipment. DEATH ON CONTACT may result if personnel fail to observe safety precautions. Be careful not to contact high-voltage connections when installing or operating this equipment. Before working inside the equipment, turn power off and ground points of high potential before touching them.

3-12. REPLACEMENT OF RT COVERS

The top and bottom RT cover removal procedures are the same. Therefore, only one procedure is provided with an illustration of the bottom cover shown.

INITIAL SETUP

Tools

Tool Kit, TK-17

Equipment Condition

RT power ON switch set to OFF.

REMOVE COVERS

STEP 1. Remove cover (1) by loosening 15 turnlock screws (2).

REPLACE COVERS

STEP 1. Apply antiseize compound (Appendix C, Item 4) to turnlock screw threads (2).

STEP 2. Position cover (1) on RT and tighten 15 cover turnlock screws (2).

STEP 3. Perform BIT, (para. 3-5).

3-12. REPLACEMENT OF RT COVERS (Cont.)

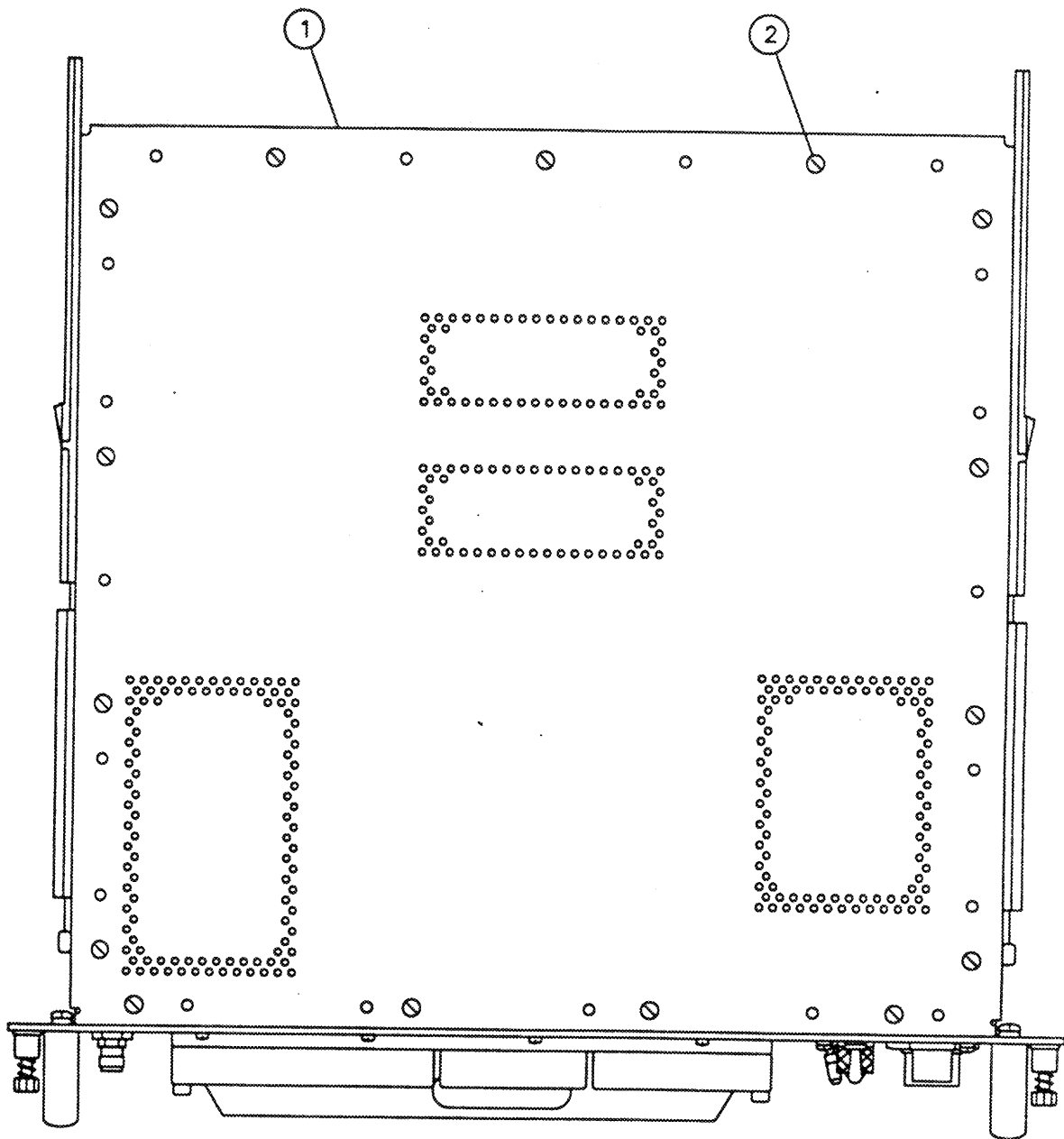

BOTTOM VIEW OF RT

3-13. REPLACEMENT OF CHASSIS CABLE ASSEMBLIES (W1,W2,W3,W6,W7,
AND W8)

INITIAL SETUP

Tools

Tool Kit, TK-17
Workstation, Static

Equipment Condition

RT power ON switch set to OFF
RT covers removed (para. 3-12)
RT power cable disconnected

Material/Parts

Chassis Cable Assembly (see NOTE below for part numbers)

CAUTION

This equipment contains components that are sensitive to damage by ESD. Improper handling will result in component and assembly failure. Use extreme caution when handling. Refer to DOD-HDBK-263 for proper handling procedures.

NOTE

The following procedure may be used to remove or replace the cable assemblies listed below.

- ① Cable Assembly W8, P/N A3024380-7
- ② Cable Assembly W6, P/N A3024380-5
- ③ Cable Assembly W7, P/N A3024780-6
- ④ Cable Assembly W3, P/N A3024381-2
- ⑤ Cable Assembly W1, P/N A3024380-3
- ⑥ Cable Assembly W2, P/N A3024380-4

REMOVE CHASSIS CABLE ASSEMBLIES W1,W2,W3,W6,W7, AND W8

STEP 1. To disconnect the cable at the module or at FL2, use needlenose pliers to grip the connector firmly and pull. When both ends of the cable assembly are disconnected, remove the cable assembly from the RT.

REPLACE CHASSIS CABLE ASSEMBLIES W1,W2,W3,W6,W7, AND W8

STEP 1. Position cable assembly connector ends over connectors to be mated with and push until properly seated.

STEP 2. Replace all assemblies removed for this procedure.

STEP 3. Replace covers.

STEP 4. Perform BIT, (para. 3-5).

3-13. REPLACEMENT OF CHASSIS CABLE ASSEMBLIES (W1,W2,W3,W6,W7, AND W8) (Cont.)

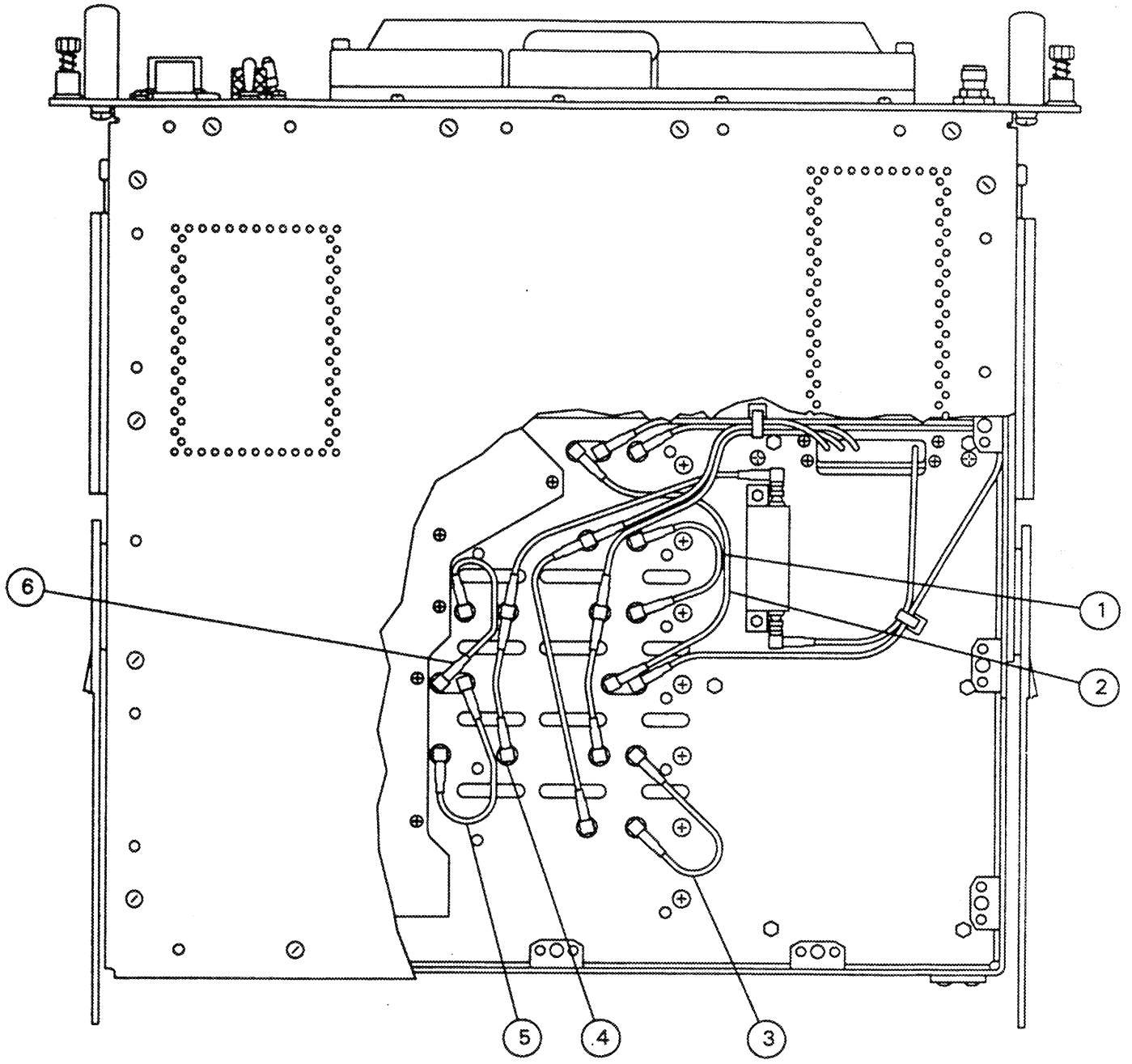

BOTTOM VIEW OF RT

3-14. REPLACEMENT OF CHASSIS CABLE ASSEMBLIES (W4, W5, W9, AND W10)

INITIAL SETUP

Tools

Tool Kit, TK-17
 Workstation, Static
 Extractor Tool,
 ITT CANNON CET-C6B

Equipment Condition

RT power ON switch set to OFF
 RT covers removed (para. 3-12)
 RT power cable disconnected
 Synthesizer Removed (para. 3-23)

Material/Parts

Chassis Cable Assembly (see NOTE below for part numbers)
 Tie-down Strap, P/N MS3367-1-9

CAUTION

This equipment contains components that are sensitive to damage by ESD. Improper handling will result in component and assembly failure. Use extreme caution when handling. Refer to DOD-HDBK-263 for proper handling procedures.

NOTE

The following procedure may be used to remove or replace the cable assemblies listed below.

- ⑤ Cable Assembly W9, P/N A3024615-1
- ⑥ Cable Assembly W10, P/N A3024615-2
- ⑦ Cable Assembly W5, P/N A3024616-3
- ⑧ Cable Assembly W4, P/N A3024616-2

REMOVE CHASSIS CABLE ASSEMBLIES W4, W5, W9, AND W10

- STEP 1. At connector J-14 ① and from the synthesizer side (top side), removed desired coax from connector J-14 using extractor tool ②.
- STEP 2. Disconnect cable assembly at module assembly or FL2 as applicable. Use needlenose pliers and grip the cable connector firmly and pull from connector.
- STEP 3. Remove tie down ③ or ④, as applicable, and remove cable assembly from RT.

3-14. REPLACEMENT OF CHASSIS CABLE ASSEMBLIES (W4, W5, W9, AND W10) (Cont.)

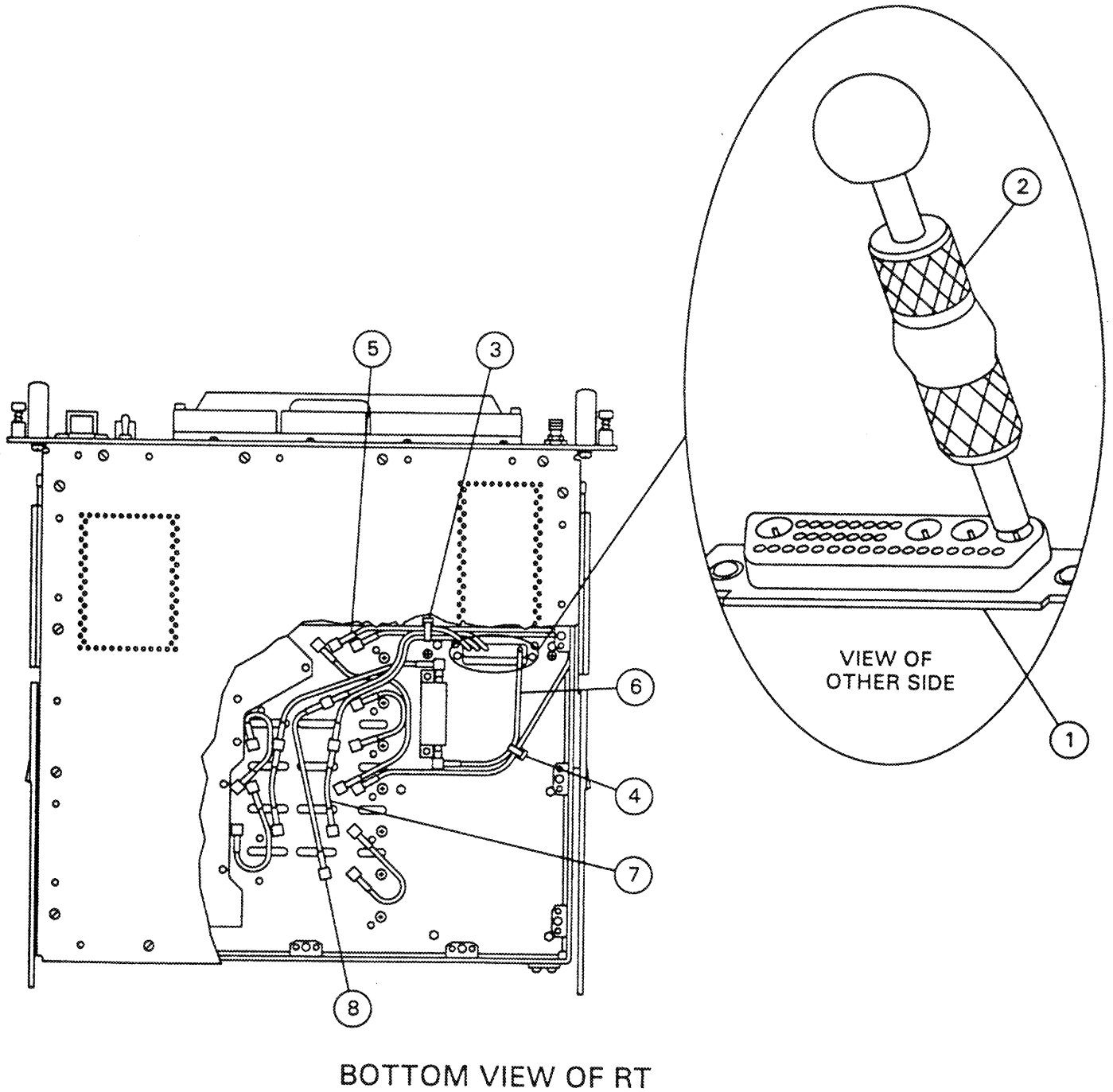

3-14. REPLACEMENT OF CHASSIS CABLE ASSEMBLIES (W4, W5, W9,
AND W10) (Cont.)

CAUTION

Do not grasp coax cable too tightly with needlenose pliers or the coax cable may be damaged.

- STEP 1. Position cable assembly connector end for insertion into the J-14 connector 1 and push to seat connector into J-14. If unable to seat connector by hand, use needle-nose pliers and carefully grasp cable assembly just above metal portion of connector and push into position. Make sure connector is fully seated.
- STEP 2. Position the connector on the other end of the cable assembly over the module connector, FL2 for W10 (6), and push to seat connector.
- STEP 3. Tie cable down with tie-down (3) or (4), as applicable.
- STEP 4. Replace all assemblies removed for this procedure.
- STEP 5. Replace covers.
- STEP 6. Perform BIT, (para. 3-5).

3-14. REPLACEMENT OF CHASSIS CABLE ASSEMBLIES (W4, W5, W9, AND W10) (Cont.)

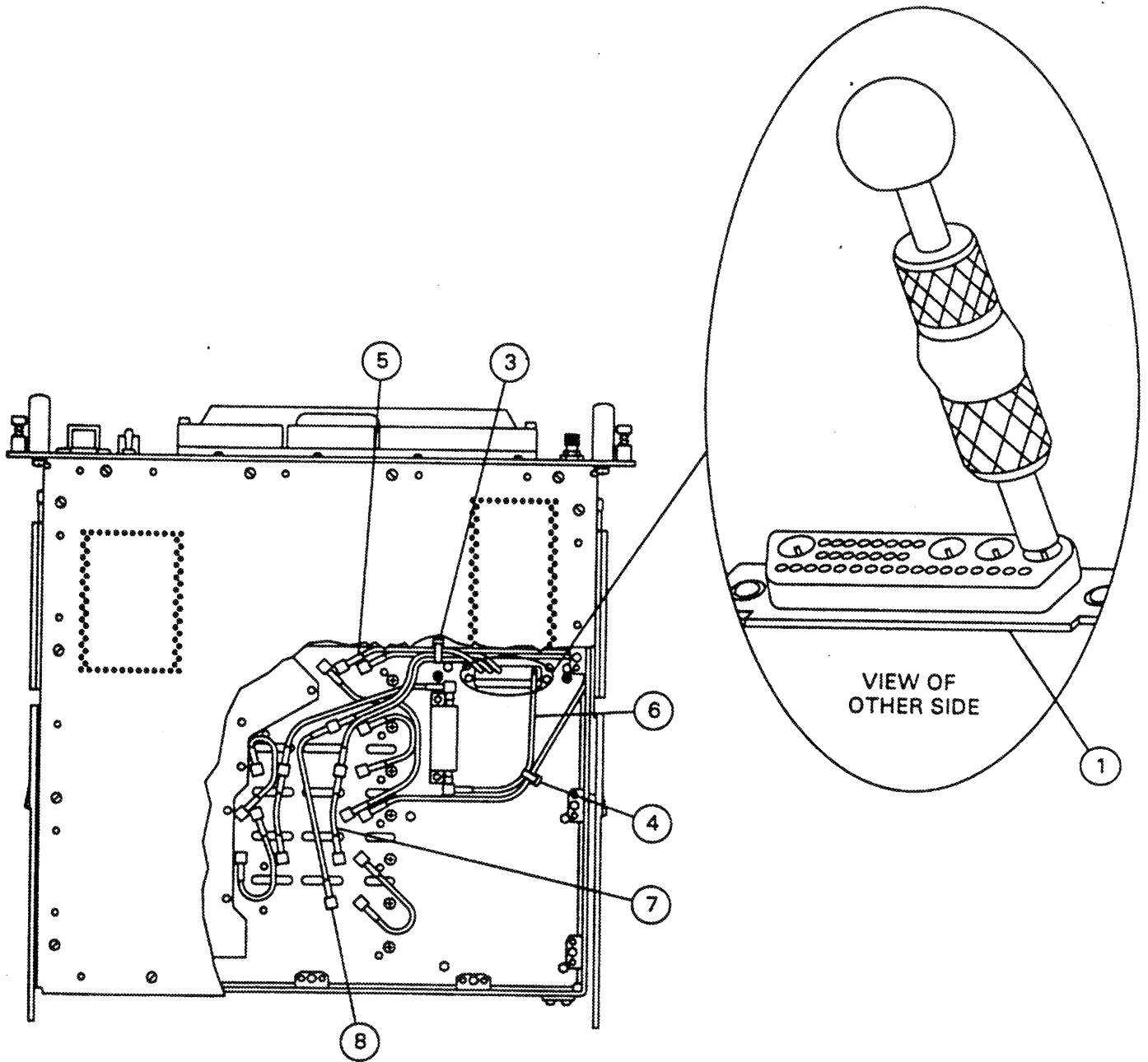

BOTTOM VIEW OF RT

3-15. REPLACEMENT OF CABLE ASSEMBLIES (A1W1 AND/OR A1W2)

INITIAL SETUP

<u>Tools</u>	<u>Equipment Condition</u>
Tool Kit, TK-17	RT power ON switch set to OFF
Workstation, Static	RT bottom cover removed, (para. 3-12)
<u>Materials/Parts</u>	RT power cable disconnected
Chassis Cable Assembly, A1W1, P/N A3024607	
Chassis Cable Assembly, A1W2, P/N A3024608	

CAUTION

This equipment contains components that are sensitive to damage by ESD. Improper handling will result in component and assembly failure. Use extreme caution when handling. Refer to DOD-HDBK-263 for proper handling procedures.

NOTE

The following procedure may be used to remove and replace cable assemblies A1W1 or A1W2.

REMOVE CABLE ASSEMBLIES A1W1 AND/OR A1W2

- STEP 1. Loosen cable assembly connector end at the module (① for A1W1 and ② for A1W2).
- STEP 2. Using needlenose pliers, grip the connector firmly and remove the cable from the module connector.
- STEP 3. Remove nut and washer ③ from connector (J9 for cable A1W1 and J10 for cable A1W2).
- STEP 4. Push connector out of front panel and remove cable assembly from RT unit.

REPLACE CABLE ASSEMBLIES A1W1 AND/OR A1W2

- STEP 1. Position cable assembly in RT with connector end of cable in front panel and secure with washer and nut ③.
- STEP 2. Connect cable assembly to module connector (① for A1W1 and ② for A1W2).
- STEP 3. Replace all assemblies removed for this procedure.
- STEP 4. Replace covers.
- STEP 5. Perform BIT, (para. 3-5).

3-15. REPLACEMENT OF CABLE ASSEMBLIES (A1W1 AND/OR A1W2) (Cont.)

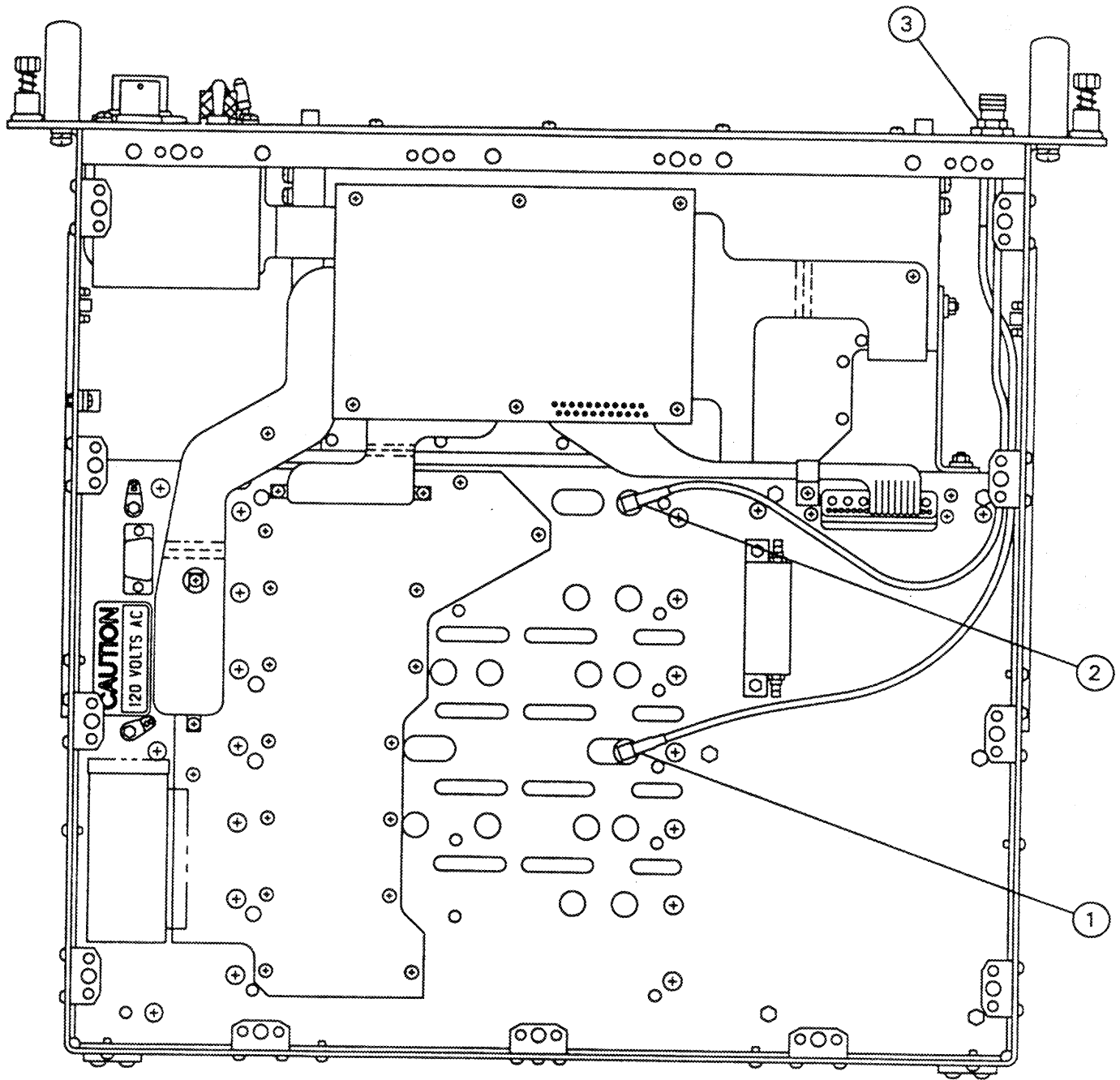

BOTTOM VIEW OF RT CHASSIS

3-16. REPLACEMENT OF CABLE ASSEMBLY (A1W4)

INITIAL SETUP

Tools

Tool Kit, TK-17
Workstation, Static

Equipment Condition

RT power ON switch set to OFF
RT covers removed (para. 3-12)
RT power cable disconnected
PS removed (para. 3-31)

Material/Parts

Cable Assembly, A1W4, P/N A3028047



This equipment contains components that are sensitive to damage by ESD. Improper handling will result in component and assembly failure. Use extreme caution when handling. Refer to DOD-HDBK-263 for proper handling procedures.

REMOVE CABLE ASSEMBLY A1W4

- STEP 1. Tag for identification and unsolder 3 wires ① from FL1 ②.
- STEP 2. Unsolder wire ③ from terminal lug E1 ④.
- STEP 3. Remove lockwasher, nut and clamp ⑤ securing cable to chassis.
- STEP 4. Remove two screws ⑥ and nuts, flatwashers, and lockwashers ⑦ securing connector ⑧ in chassis.
- STEP 5. Remove cable assembly A1W4.

REPLACE CABLE ASSEMBLY A1W4

- STEP 1. Place connector ⑧ into position in chassis and secure with two screws ⑥ and nuts, flatwasher, and lockwashers ⑦.
- STEP 2. Secure cable to chassis with clamp, nut, lockwasher, and screw ⑤.
- STEP 3. Solder wire ③ to terminal lug E1 ④.
- STEP 4. Solder three wires ① to connections on FL1 ②.
- STEP 5. Replace all assemblies removed for this procedure.
- STEP 6. Replace covers.
- STEP 7. Perform BIT, (para. 3-5).

3-16. REPLACEMENT OF CABLE ASSEMBLY (A1W4) (Cont.)

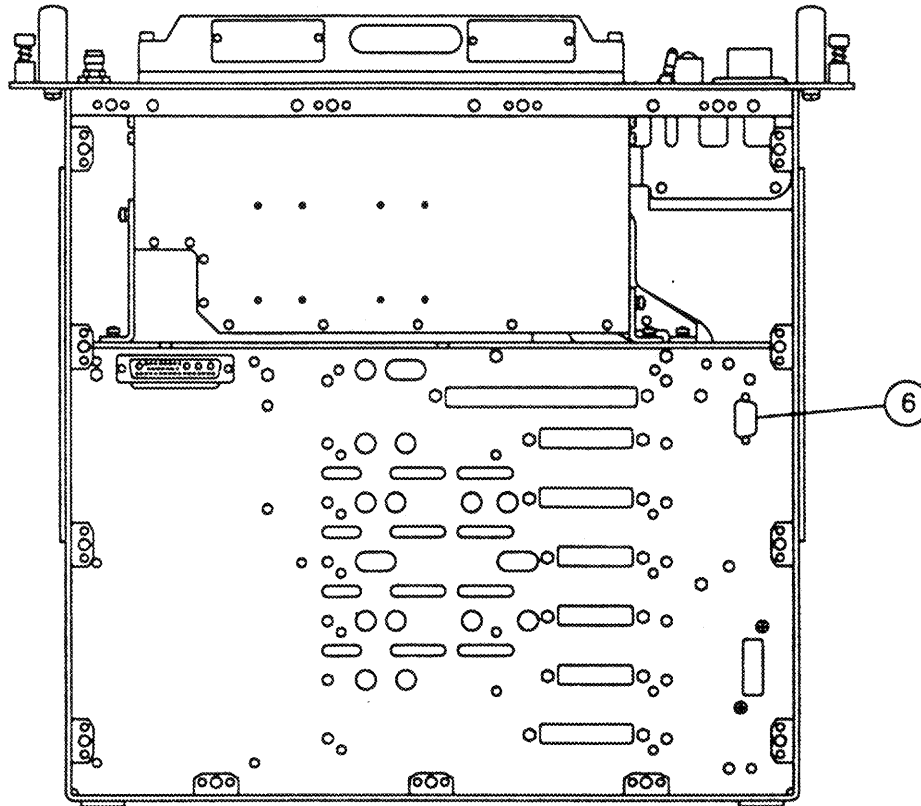

TOP VIEW OF CHASSIS

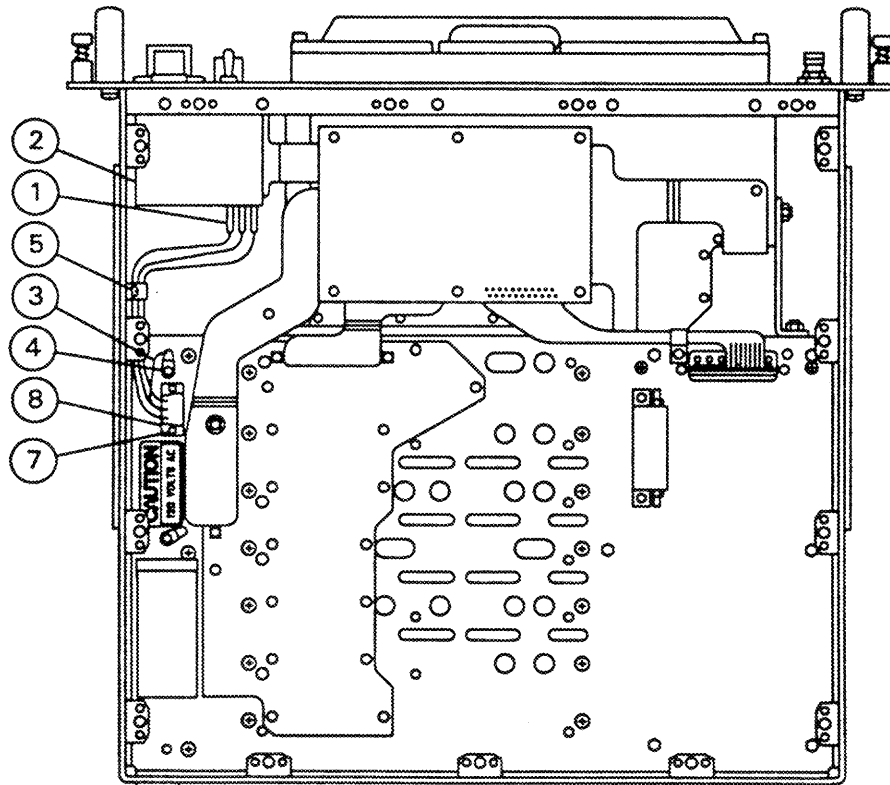

BOTTOM VIEW OF CHASSIS

3-17. REPLACEMENT OF MODULE INTERCONNECT CCA (A1A1)

INITIAL SETUP

Tools

Tool Kit, TK-17
Workstation, Static

Materials/Parts

Chassis Module Interconnect CCA,
A1A1, P/N A3024659
Small straps, tie-down P/N B96906MS3367-4-9

Equipment Condition

RT power ON switch set to OFF
RT covers removed (para. 3-12)
RT power cable disconnected
All modules removed,
(para. 3-23 thru 3-31)

CAUTION

This equipment contains components that are sensitive to damage by ESD. Improper handling will result in component and assembly failure. Use extreme caution when handling. Refer to DOD-HDBK-263 for proper handling procedures.

REMOVE CHASSIS MODULE INTERCONNECT CCA (MOTHERBOARD)

- STEP 1. Remove 2 screws, flatwashers, and lockwashers ① on connector ② and pull flex cable connector from motherboard ③.
- STEP 2. Remove 2 screws, flatwashers, and lockwashers ④ on connector ⑤ and pull flex cable connector from motherboard ③.
- STEP 3. Remove screw, flatwasher, and lockwasher ⑥ that secures flex cable to chassis.
- STEP 4. Unsolder white wire ⑦ from E2 that connects to motherboard ③.
- STEP 5. Tag leads from motherboard ③ to FL3 ⑧ for reconnection when replacing motherboard.
- STEP 6. Remove 2 cable straps ⑨ around wiring harness.
- STEP 7. Unsolder all leads at FL3 ⑧ that come from the motherboard ③.
- STEP 8. Loosen 18 screws, flatwashers, and lockwashers ⑩ securing motherboard ③ in chassis and remove motherboard from chassis.

3-17. REPLACEMENT OF MODULE INTERCONNECT CCA (A1A1) (Cont.)

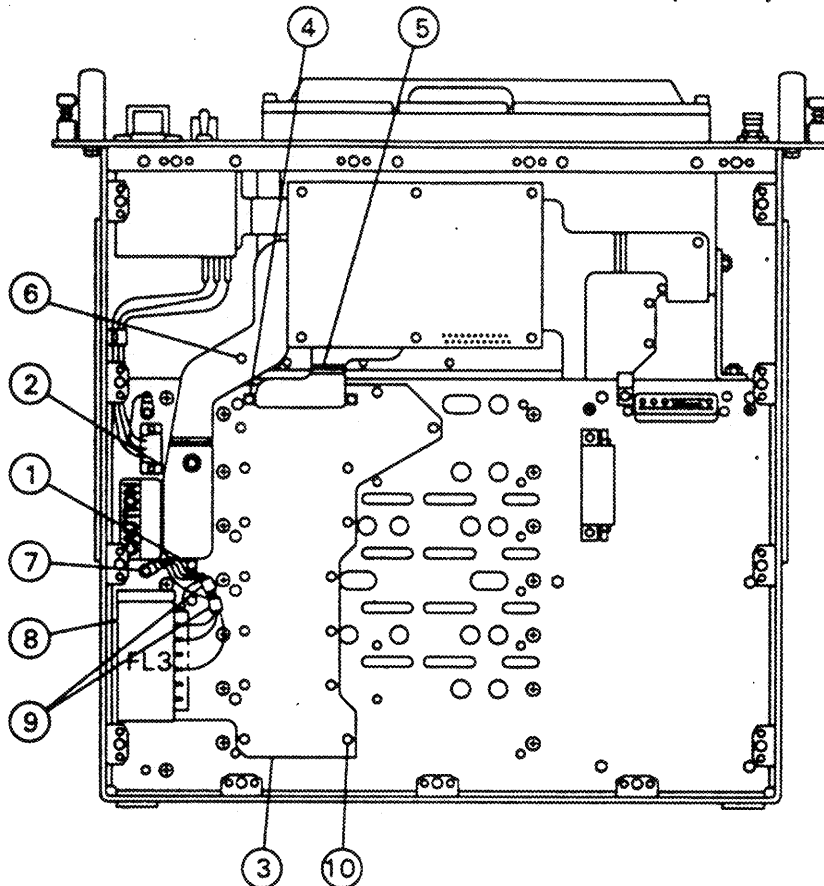

BOTTOM VIEW OF RT CHASSIS

REPLACE CHASSIS MODULE INTERCONNECT CCA (MOTHERBOARD)

- STEP 1. Position motherboards (3) in chassis, insert and tighten 18 screws, flatwashers, and lockwashers (10) securing motherboards (3) on chassis.
- STEP 2. Solder all leads at FL3 (8) from motherboards (3) as noted in step 7 of removal.
- STEP 3. Install cable straps (9) around cable assembly.
- STEP 4. Solder white wire (7) to E2 as noted in step 4 of removal.
- STEP 5. Insert and tighten screw, flatwasher, and lockwasher (6) that secures flex cable to chassis.
- STEP 6. Push connector (2) into place on motherboards (3), insert and tighten 2 screws, flatwashers, and lockwashers (1).
- STEP 7. Push connector (5) into place on motherboards (3), insert and tighten 2 screws, flatwashers, and lockwashers (4).
- STEP 8. Replace all assemblies removed for this procedure.
- STEP 9. Replace covers.
- STEP 10. Perform BIT, (para. 3-5).

3-18. REPLACEMENT OF PRINTED CABLE ASSEMBLY, FLEXIBLE INTERCONNECT (A1W3)

INITIAL SETUP

Tools

Tool Kit, TK-17
Workstation, Static

Materials/Parts

Chassis Printed Cable Assembly,
Flexible Interconnect, A1W3,
P/N A3024609

Equipment Condition

RT power ON switch set to OFF
RT covers removed (para. 3-12)
RT power cable disconnected
ECCM removed (para. 2-13)
Synthesizer removed
(para. 3-23)
Reference oscillator removed,
(para. 3-24)

CAUTION

This equipment contains components that are sensitive to damage by ESD. Improper handling will result in component and assembly failure. Use extreme caution when handling. Refer to DOD-HDBK-263 for proper handling procedures.

REMOVE CHASSIS PRINTED CABLE ASSEMBLY, FLEXIBLE INTERCONNECT

- STEP 1. Unsolder leads, at back side of front panel, ① from Power ON Indicator ②.
- STEP 2. Remove nut and starwasher ③ on front panel from LOCAL/REMOTE Switch ④.
- STEP 3. Remove 2 screws, flatwashers, and lockwashers ⑤ securing flex cable to FL1 ⑥.
- STEP 4. Remove spanner nut ⑦ from connector J7 ⑧ and push connector ⑧ and LOCAL/REMOTE switch ④ out of front panel ①.
- STEP 5. Carefully feed flex cable ⑨ with connector J7 ⑧ and switch ④ attached out through the opening by FL1 ⑥ and the top of the chassis assembly.
- STEP 6. Remove 4 coax cables ⑩, on the bottom of connector J14 ⑪, para. 3-14.
- STEP 7. Remove 2 screws, flatwashers, and lockwashers ⑫ from connector J14 ⑪.

3-18. REPLACEMENT OF CHASSIS PRINTED CABLE ASSEMBLY, FLEXIBLE INTERCONNECT (A1W3) (Cont.)

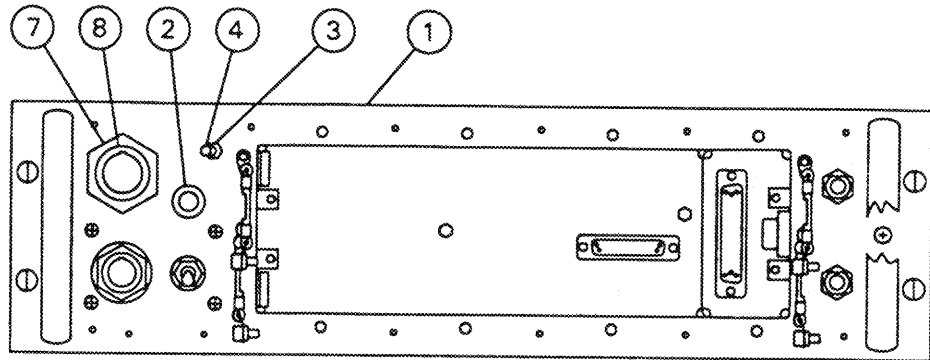

FRONT VIEW OF RT

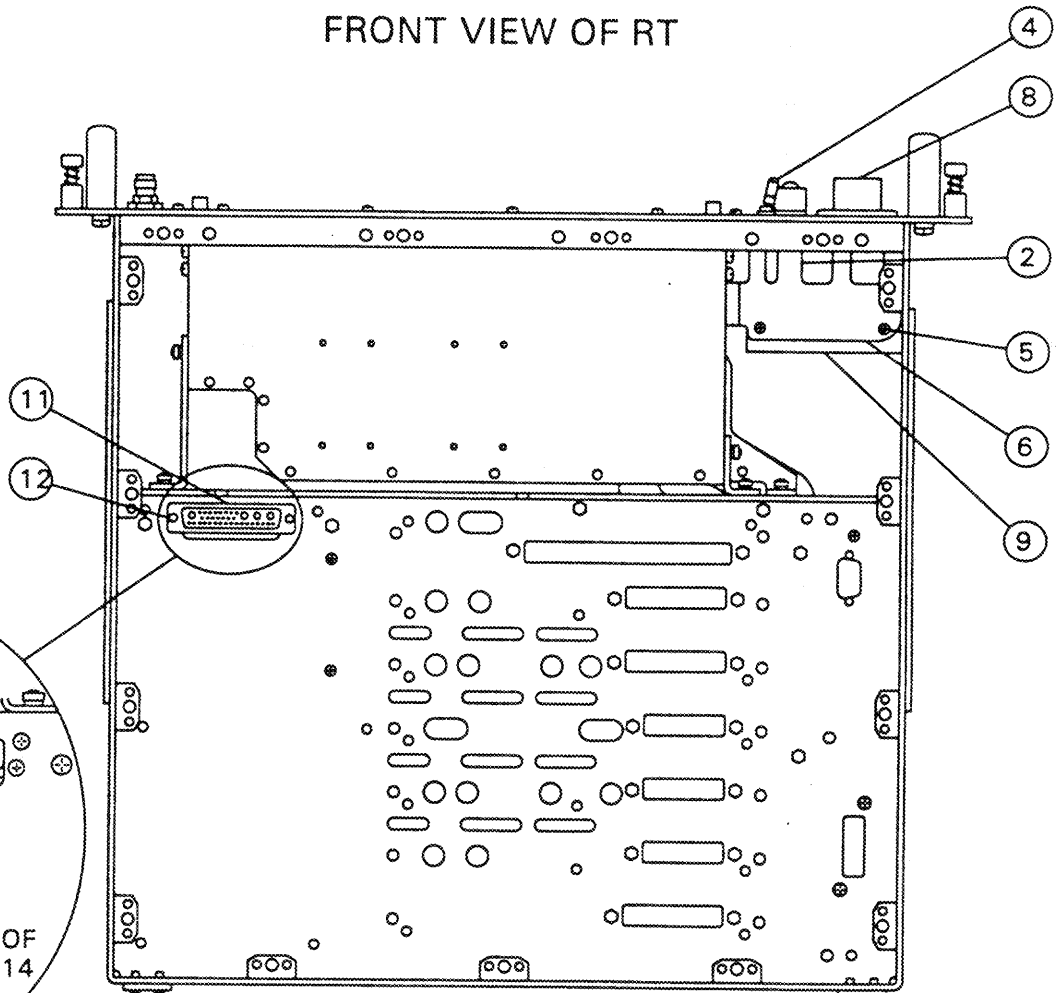

TOP VIEW OF RT CHASSIS

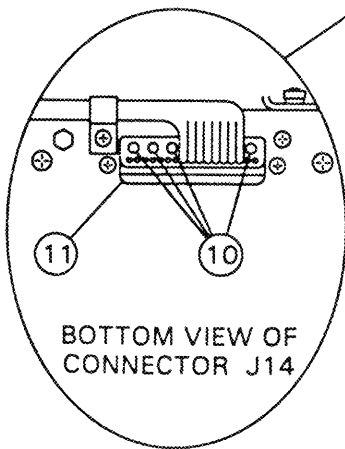

BOTTOM VIEW OF CONNECTOR J14

3-18. REPLACEMENT OF CHASSIS PRINTED CABLE ASSEMBLY, FLEXIBLE INTERCONNECT (A1W3) (Cont.)

REMOVE CHASSIS PRINTED CABLE ASSEMBLY, FLEXIBLE INTERCONNECT (Cont.)

- STEP 8. Loosen 2 screws, flatwashers, and lockwashers ① and ② in flex cable connector ③ and pull connector from motherboard ④.
- STEP 9. Loosen 2 screws, flatwashers, and lockwashers ⑤ in flex cable connector ⑥ and pull connector from motherboard ④.
- STEP 10. Remove screw, flatwasher, and lockwasher ⑦ securing flex cable to RT chassis.
- STEP 11. Remove screw, flatwasher, and lockwasher ⑧ securing flex cable to RT chassis.
- STEP 12. Remove 2 screws, lockwashers, and nuts ⑨ (in ECCM cavity of front panel) in connector ⑩ and push connector out the rear of ECCM cavity ⑪.
- STEP 13. Remove 2 screws, lockwashers, and nuts ⑫ (in ECCM cavity of front panel) in connector ⑬ and push connector out the rear of ECCM cavity ⑪.
- STEP 14. Carefully feed flex cable ⑭ with connector ⑩ attached out to the plane of chassis matrix board ⑮.
- STEP 15. Remove screw, washer, and loop clamp ⑯ from wire cable to connector J14 ⑰.
- STEP 16. Maneuver connector J14 ⑰, with wire cable attached, out of chassis assembly.
- STEP 17. Carefully feed flex cable ⑱ with connector ⑬ attached out to the plane of chassis matrix board ⑮.
- STEP 18. Remove 6 screws, flatwashers, and lockwashers ⑲ securing chassis matrix board ⑮ in RT chassis.
- STEP 19. Remove chassis matrix board ⑮ from RT chassis.

3-18. REPLACEMENT OF CHASSIS PRINTED CABLE ASSEMBLY, FLEXIBLE INTERCONNECT (A1W3) (Cont.)

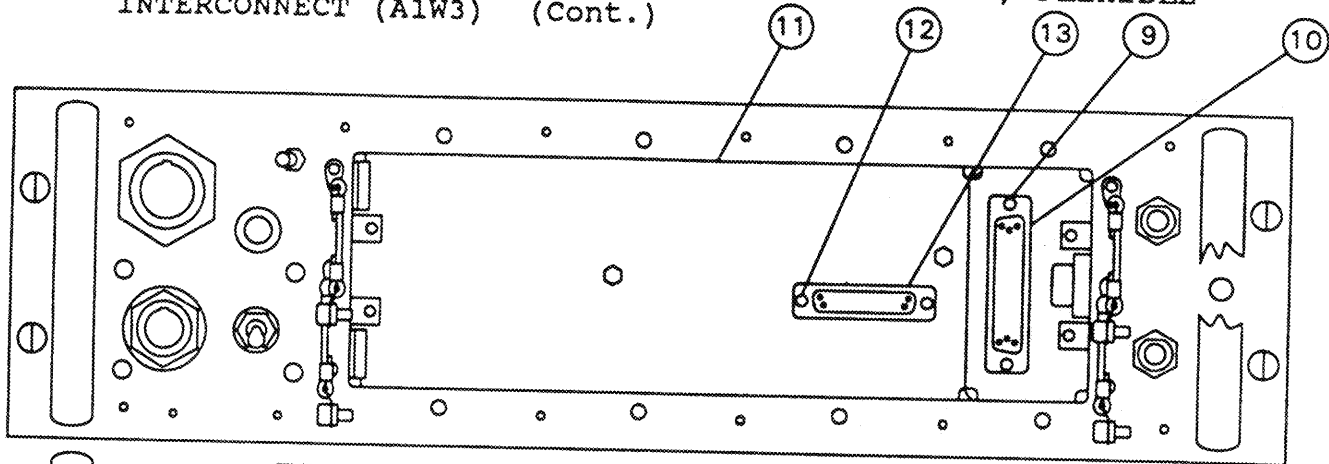

FRONT VIEW OF UNIT, ECCM REMOVED

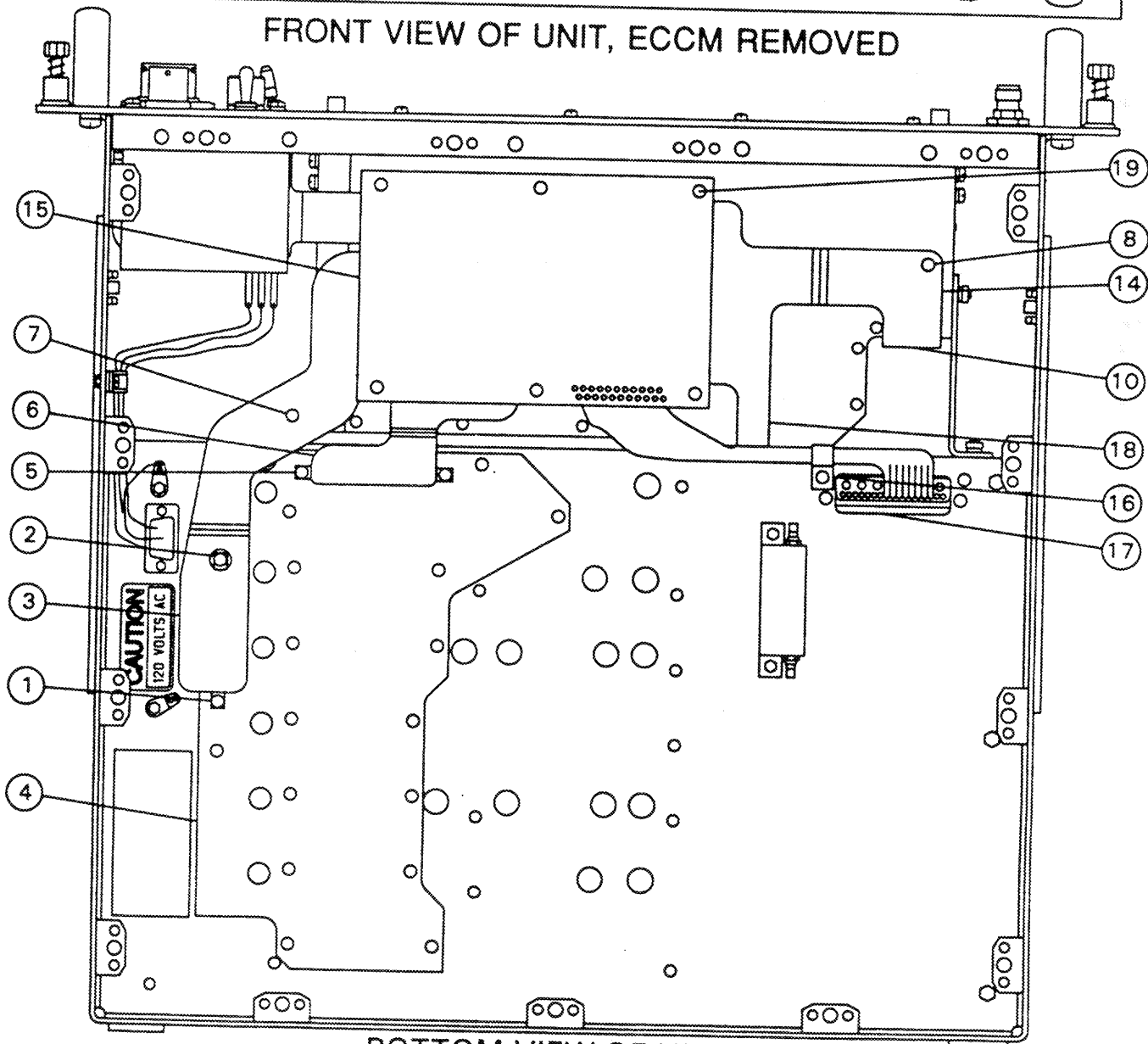

BOTTOM VIEW OF UNIT

3-18. REPLACEMENT OF CHASSIS PRINTED CABLE ASSEMBLY, FLEXIBLE INTERCONNECT (A1W3) (Cont.)

REPLACE CHASSIS PRINTED CABLE ASSEMBLY, FLEXIBLE INTERCONNECT

- STEP 1. Carefully feed flex cable with connector J14 (17) attached into proper area for mounting.
- STEP 2. Carefully feed flex cable (18) with connector (13) attached into the proper area for mounting.
- STEP 3. Carefully feed flex cable (14) with connector (10) attached into the proper area for mounting.
- STEP 4. Insert 6 screws, lockwashers, and standoffs (19) for holding matrix board on chassis and secure matrix board (15) to RT chassis.
- STEP 5. Position loop clamp (16) over wire cable and secure with washer and screw.
- STEP 6. Insert and tighten screw, flatwasher, and lockwasher (7) that secures flex cable to chassis.
- STEP 7. Insert 2 screws (12) into connector (13) and secure to chassis with standoffs, lockwashers, and nuts.
- STEP 8. Insert 2 screws (9) into connector (10) and secure to chassis with lockwashers and nuts.
- STEP 9. Insert and tighten screw, flatwasher, and lockwasher (8) that secures flex cable (14) to chassis.
- STEP 10. Plug connector (6) into motherboard (4), insert and tighten 2 screws, flatwashers, and lockwashers (5).
- STEP 11. Plug connector (3) into motherboard (4), insert and tighten 2 screws, flatwashers, and lockwashers (1) and (2).

3-18. REPLACEMENT OF CHASSIS PRINTED CABLE ASSEMBLY, FLEXIBLE INTERCONNECT (A1W3) (Cont.)

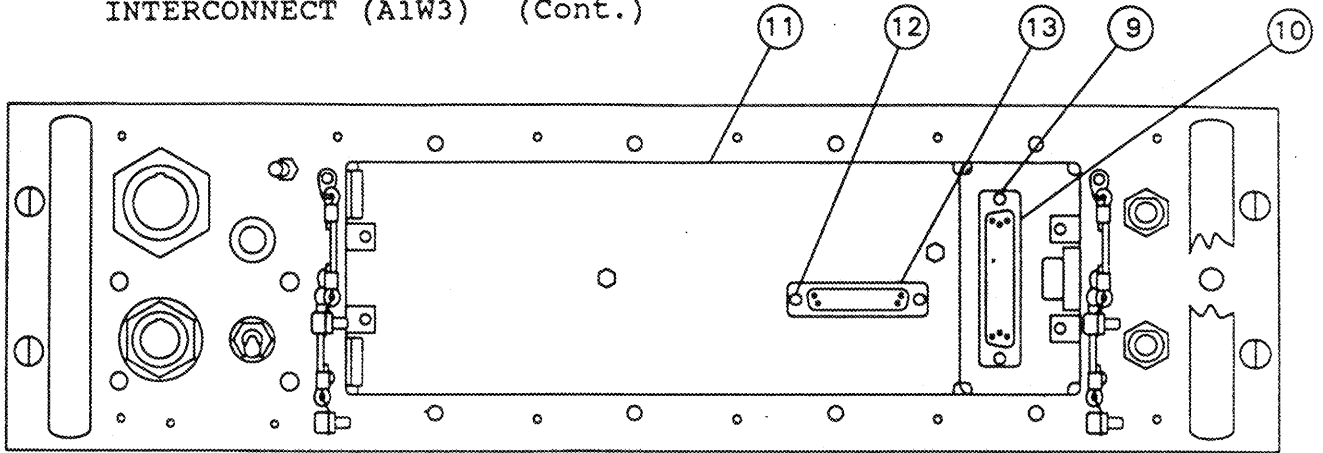

FRONT VIEW OF UNIT, ECCM REMOVED

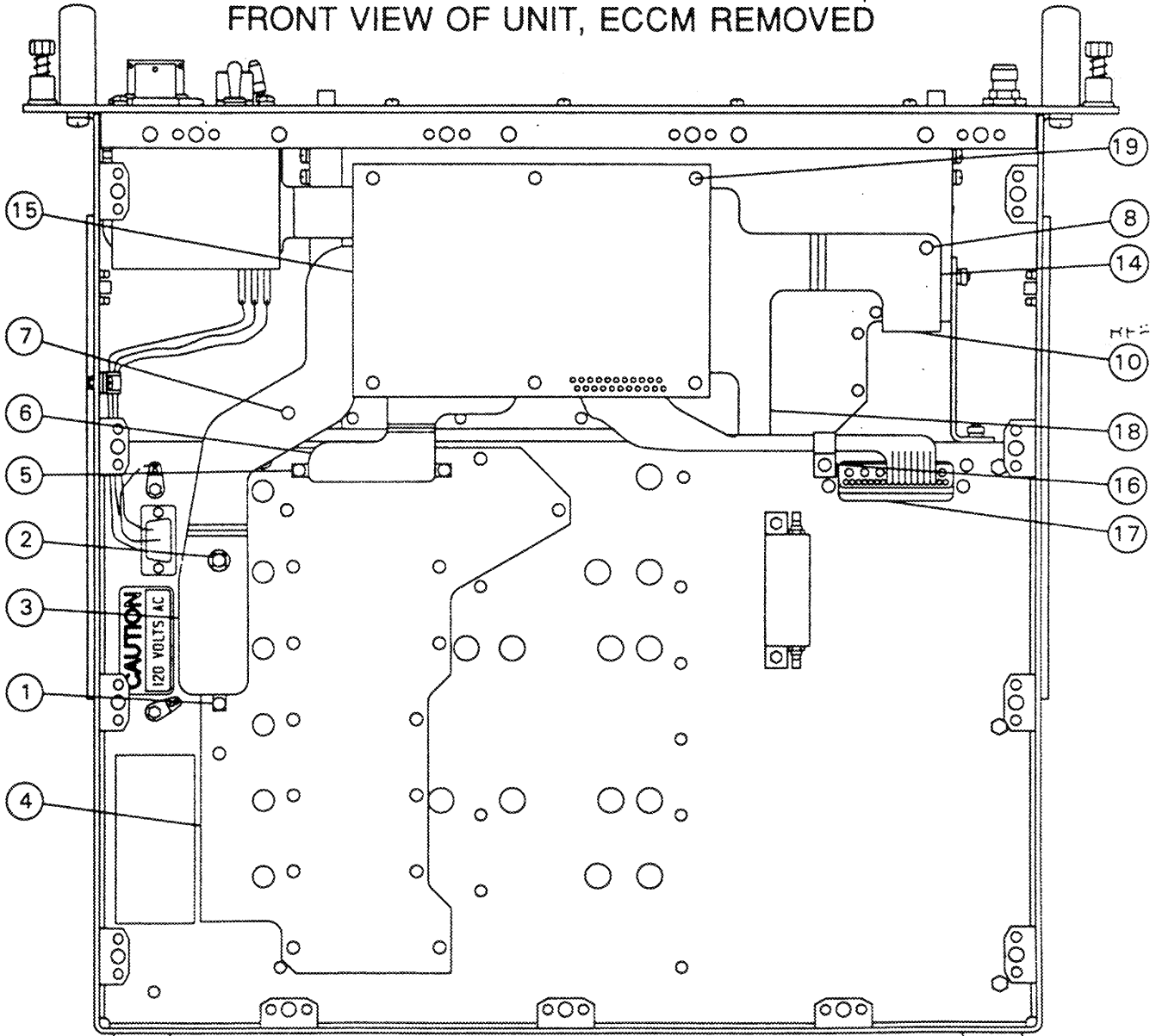

BOTTOM VIEW OF UNIT

3-18. REPLACEMENT OF CHASSIS PRINTED CABLE ASSEMBLY, FLEXIBLE INTERCONNECT (A1W3) (Cont.)

- STEP 12. Insert and tighten 2 screws, flatwashers, and lockwashers (12) in connector J14 (11) securing connector to chassis.
- STEP 13. Insert 4 coax cables (10) in back side of connector J14 (11), para. 3-14.
- STEP 14. Carefully feed flex cable (6) with connector J7 (8) and LOCAL/REMOTE switch (4) attached into the proper area.
- STEP 15. Push connector J7 (8) into front panel (1). Install and tighten spanner nut (7).
- STEP 16. Push LOCAL/REMOTE switch (4) into front panel and secure with nut and starwasher (3).
- STEP 17. Insert and tighten 2 screws, flatwashers, and lockwashers (5) that secures flex cable to FL1 (9).
- STEP 18. Solder flex leads to Power ON Indicator (2).
- STEP 19. Replace all assemblies removed for this procedure.
- STEP 20. Replace covers.
- STEP 21. Perform BIT, (para. 3-5).

3-18. REPLACEMENT OF CHASSIS PRINTED CABLE ASSEMBLY, FLEXIBLE INTERCONNECT (A1W3) (Cont.)

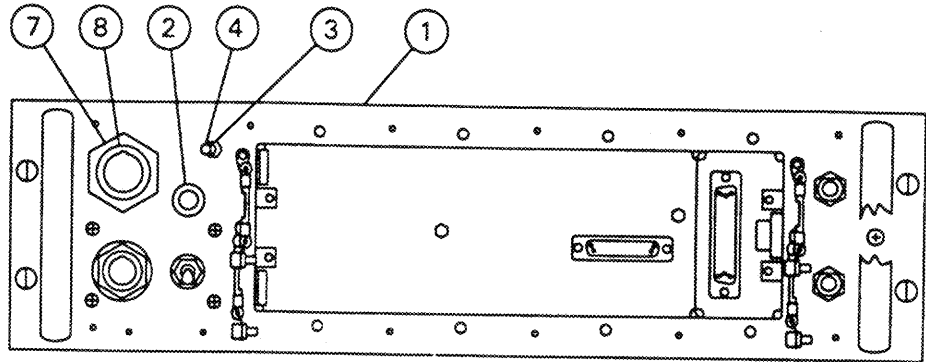

FRONT VIEW OF UNIT, ECCM REMOVED

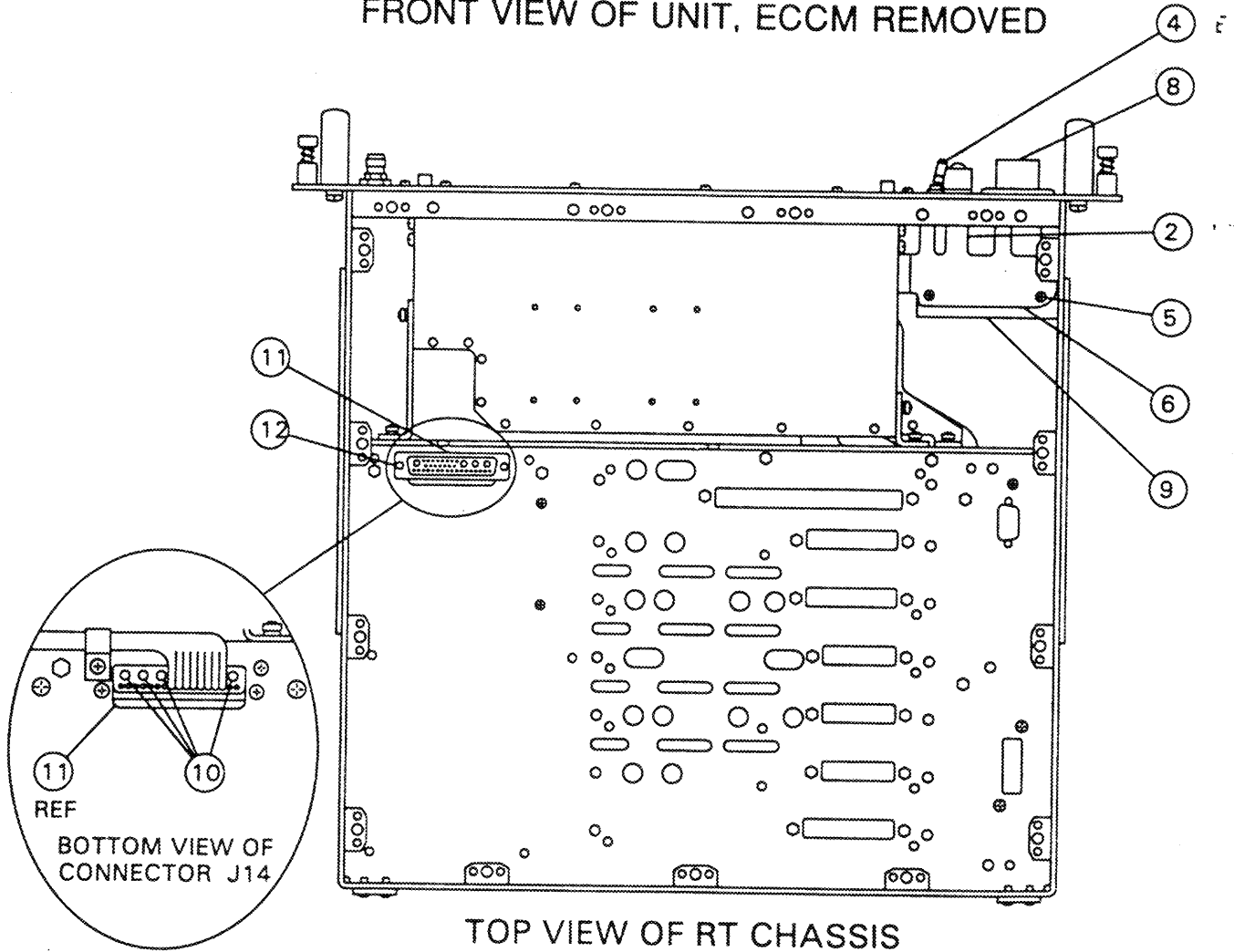

TOP VIEW OF RT CHASSIS

3-19. REPLACEMENT OF EMI FILTER (FL1)

INITIAL SETUP

Tools

Tool Kit, TK-17
Workstation, Static

Equipment Condition

RT power On switch set to OFF
RT Covers Removed (para. 3-12)
RT power cable disconnected

Material/Parts

EMI Filter, FL1, P/N A3024126

CAUTION

This equipment contains components that are sensitive to damage by ESD. Improper handling will result in component and assembly failure. Use extreme caution when handling. Refer to DOD-HDBK-263 for proper handling procedures.

REMOVE EMI FILTER FL1

- STEP 1. Tag and unsolder 3 wires ① connected to the bottom of FL1 ②.
- STEP 2. Remove 2 screws, flatwashers, and lockwashers ③ securing flex cable ④ to FL1.
- STEP 3. Remove 4 screws ⑤ securing filter to front panel ⑥.
- STEP 4. Maneuver filter down and out the bottom side of the RT.

REPLACE EMI FILTER FL1

- STEP 1. Maneuver filter into mounted position from the bottom side of the RT.
- STEP 2. Secure filter to front panel ⑥ with 4 mounting screws ⑤.
- STEP 3. Insert and tighten 2 screws, lockwashers, and flatwashers ③ that secure flex cable ④ to FL1 ②.
- STEP 4. Solder 3 wire leads ① to FL1 as tagged from the removal procedure, step 1.
- STEP 5. Replace all assemblies removed for this procedure.
- STEP 6. Replace covers.
- STEP 7. Perform BIT, (para. 3-5).

3-19. REPLACEMENT OF EMI FILTER (FL1) (Cont.)

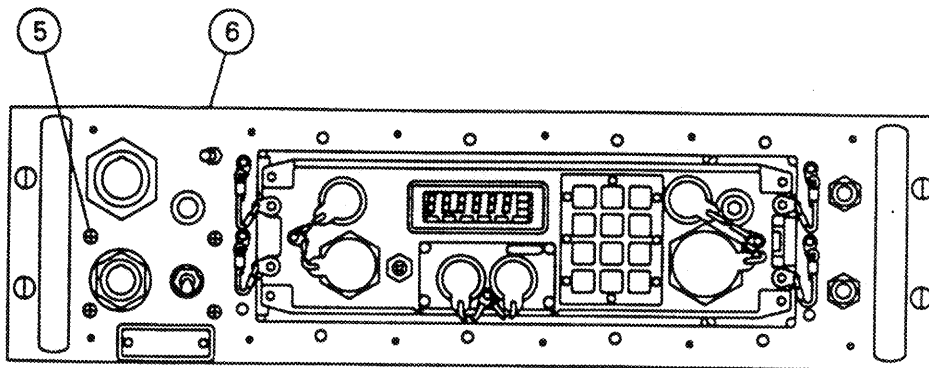

FRONT PANEL

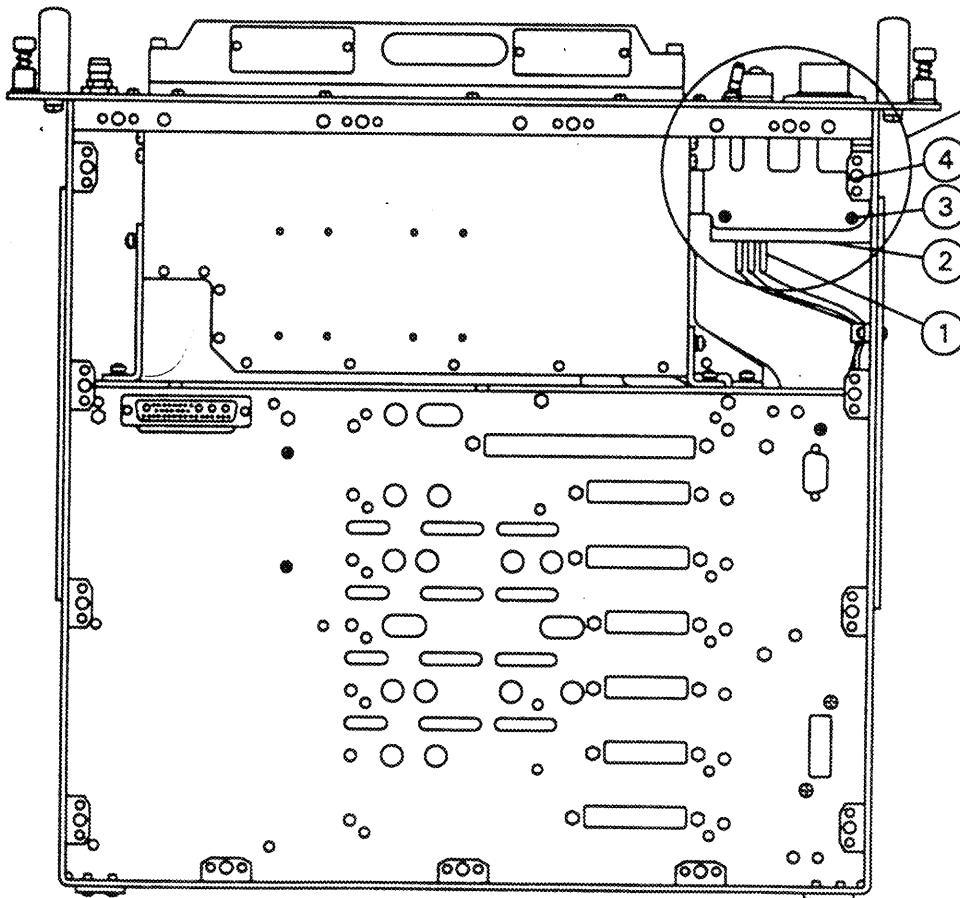

TOP VIEW OF RT CHASSIS

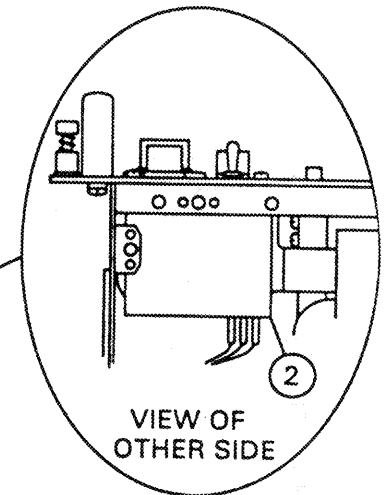

VIEW OF OTHER SIDE

3-20. REPLACEMENT OF BAND PASS FILTER AND BAND SUPPRESSION (FL2)

INITIAL SETUP

Tools

Tool Kit, TK-17
Workstation, Static

Equipment Condition

RT power ON switch set to OFF
RT covers removed (para. 3-12)
RT power cable disconnected
Synthesizer Removed (para. 3-23)

Materials/Parts

Band Pass Filter and Band Suppression,
FL2, P/N A3024059

CAUTION

This equipment contains components that are sensitive to damage by ESD. Improper handling will result in component and assembly failure. Use extreme caution when handling. Refer to DOD-HDBK-263 for proper handling procedures.

REMOVE FILTER FL2

- STEP 1. Disconnect 2 coax leads ① from FL2 ②.
- STEP 2. Remove 2 screws ③ flatwashers, lockwashers, and nuts ④ securing FL2 to chassis and remove FL2.

REPLACE FILTER FL2

- STEP 1. Position FL2 ② in mounted position.
- STEP 2. Insert 2 screws ③ flatwashers, lockwashers, and nuts ④ and tighten screws to secure FL2 in chassis.
- STEP 3. Connect 2 coax cables ① to FL2.
- STEP 4. Replace all assemblies removed for this procedure.
- STEP 5. Replace covers.
- STEP 6. Perform BIT, (para. 3-5).

3-20. REPLACEMENT OF BAND PASS FILTER AND BAND SUPPRESSION (FL2)
(Cont.)

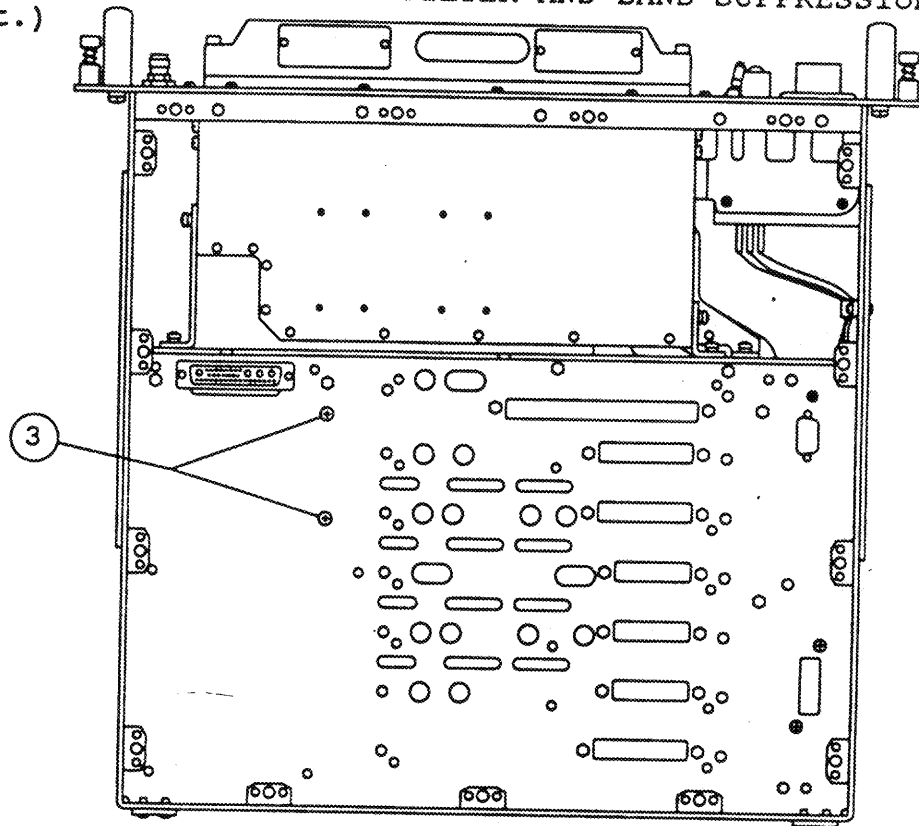

TOP VIEW OF CHASSIS

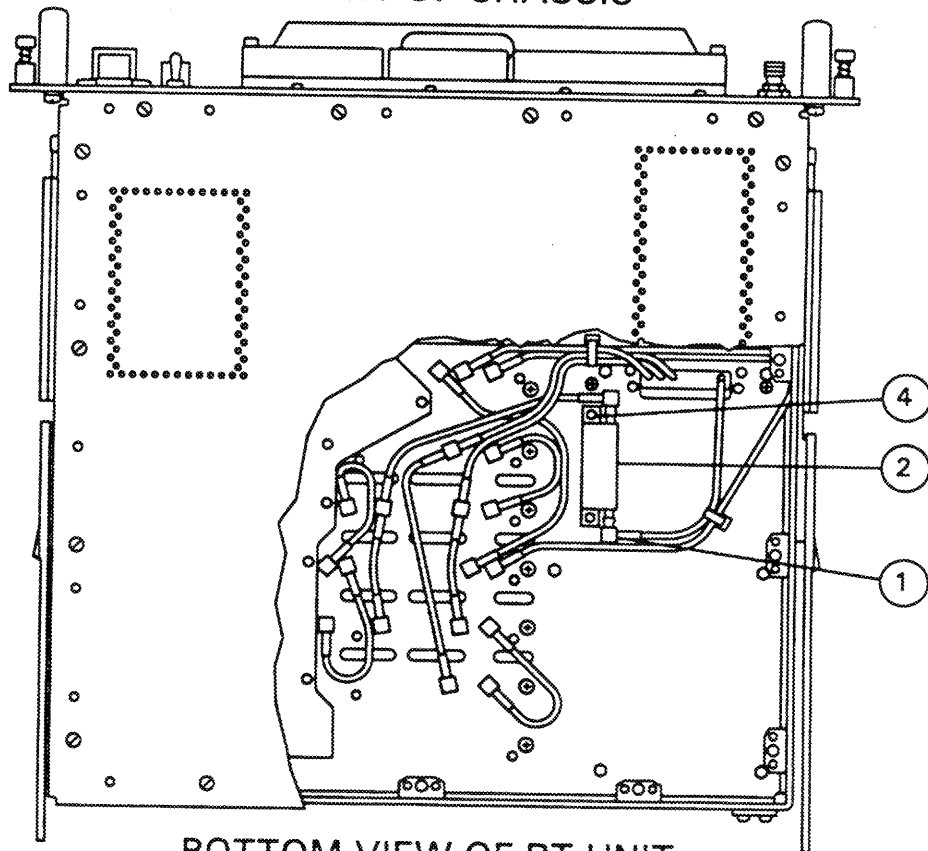

BOTTOM VIEW OF RT UNIT

3-21. REPLACEMENT OF RADIO FREQUENCY MULTICIRCUIT FILTER (FL3)

INITIAL SETUP

Tools

Tool Kit, TK-17
Workstation, Static

Materials/Parts

Radio Frequency Multicircuit Filter,
FL3, P/N A3034047

Equipment Condition

RT power ON switch set to OFF
RT covers removed (para. 3-12)
RT power cable disconnected
PS removed (para. 3-31)

CAUTION

This equipment contains components that are sensitive to damage by ESD. Improper handling will result in component and assembly failure. Use extreme caution when handling. Refer to DOD-HDBK-263 for proper handling procedures.

REMOVE FILTER, FL3

- STEP 1. Tag and unsolder the wires connected to the 8 solder connections ① on FL3 ②.
- STEP 2. Remove 2 screws ③ securing FL3 to chassis and remove FL3.

REPLACE FILTER FL3

- STEP 1. Place FL3 ② in mounted position and secure with 2 screws ③.
- STEP 2. Solder wire leads to 8 connections ① on FL3 ② as tagged from removal procedure, step 1.
- STEP 3. Replace all assemblies removed for this procedure.
- STEP 4. Replace covers.
- STEP 5. Perform BIT, (para 3-5).

3-21. REPLACEMENT OF RADIO FREQUENCY MULTICIRCUIT FILTER (FL3)
(Cont.)

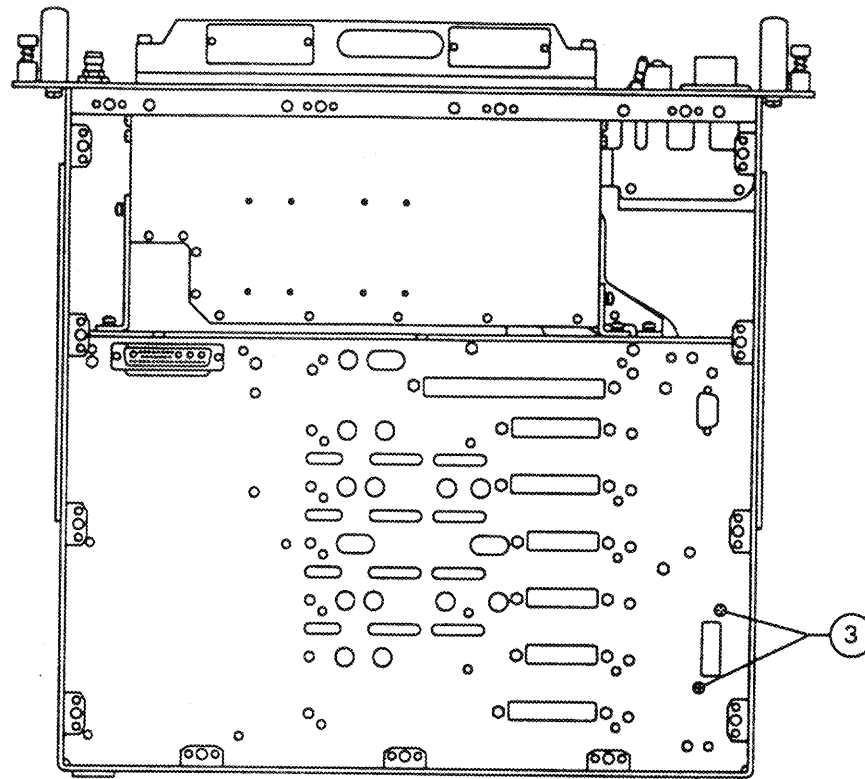

TOP VIEW OF RT CHASSIS

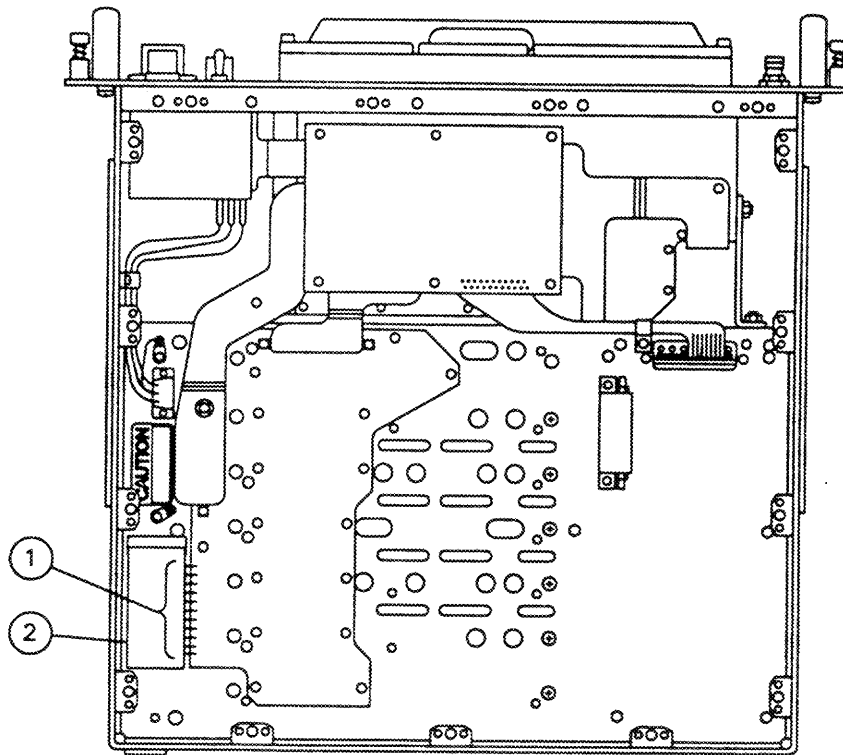

BOTTOM VIEW OF RT CHASSIS

3-22. REPLACEMENT OF CONTROLLER, RECEIVER-TRANSMITTER C-11670/G

Replace the ECCM module per para. 2-13 of this manual.

3-23. REPLACEMENT OF SYNTHESIZER (A3)

INITIAL SETUP

Tools

Tool Kit, TK-17
Workstation, Static

Equipment Condition

RT power ON switch set to OFF
RT covers removed (para. 3-12)
RT power cable disconnected

Materials/Parts

Synthesizer, A3, P/N A3024340

CAUTION

This equipment contains components that are sensitive to damage by ESD. Improper handling will result in component and assembly failure. Use extreme caution when handling. Refer to DOD-HDBK-263 for proper handling procedures.

REMOVE FREQUENCY SYNTHESIZER

- STEP 1. Loosen 6 captive screws ① securing synthesizer ② in the RT.
- STEP 2. Unplug synthesizer ② from RT by pulling synthesizer up and out of chassis.

REPLACE FREQUENCY SYNTHESIZER

- STEP 1. Place synthesizer ② into position in chassis and carefully push down to make electrical connections.
- STEP 2. Tighten 6 captive screws ① securing synthesizer ② in the RT.
- STEP 3. Replace all assemblies removed for this procedure.
- STEP 4. Replace covers.
- STEP 5. Perform BIT, (para. 3-5).

3-23. REPLACEMENT OF SYNTHESIZER (A3) (Cont.)

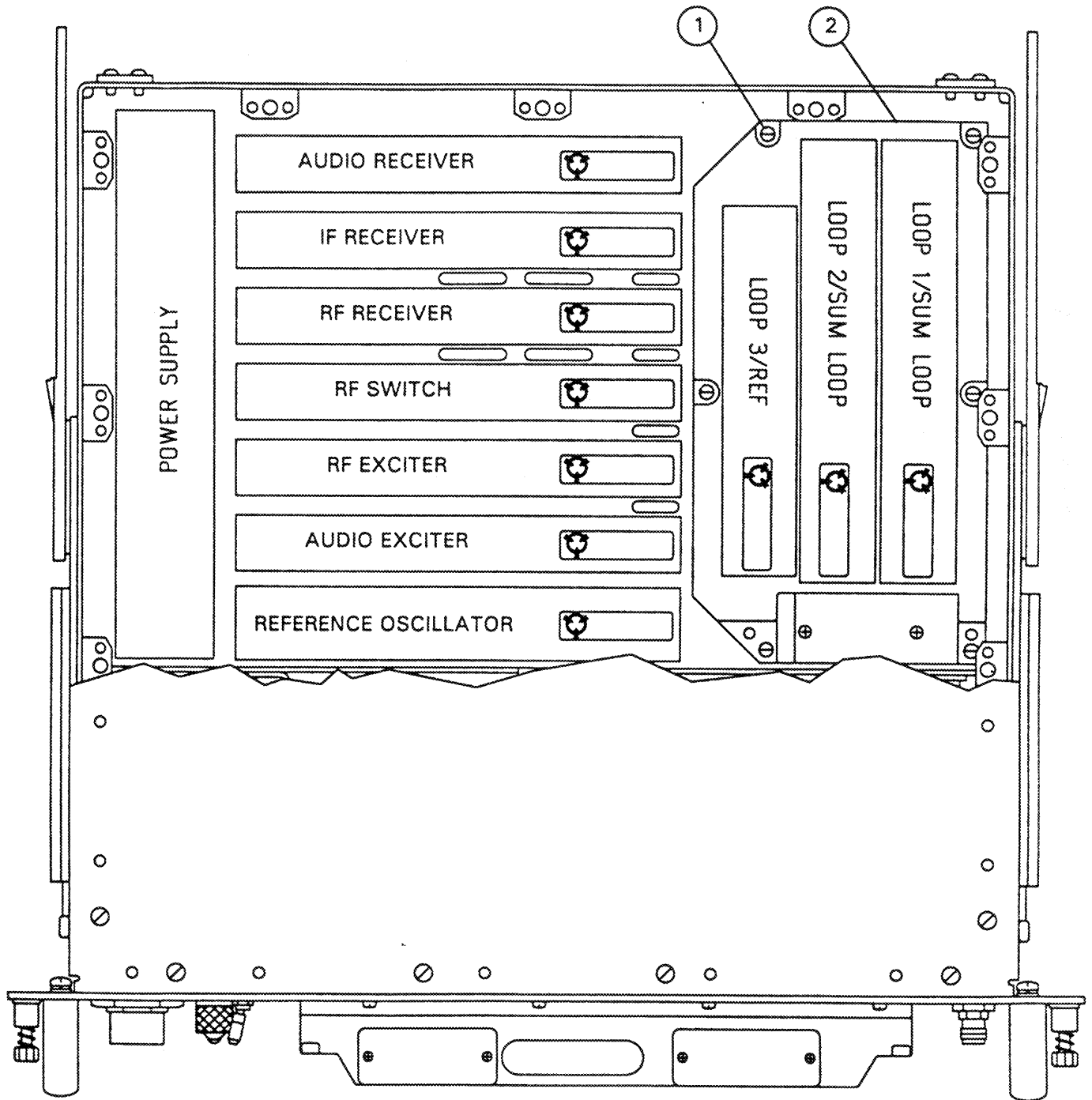

UNIT VIEWED FROM TOP

3-24. REPLACEMENT OF REFERENCE OSCILLATOR ASSEMBLY (A4)

INITIAL SETUP

<u>Tools</u>	<u>Equipment Condition</u>
Tool Kit, TK-17 Workstation, Static	RT power ON switch set to OFF RT covers removed (para. 3-12) RT power cable disconnected
<u>Materials/Parts</u>	
Reference Oscillator Assembly, A4, P/N A3024618	

CAUTION

This equipment contains components that are sensitive to damage by ESD. Improper handling will result in component and assembly failure. Use extreme caution when handling. Refer to DOD-HDBK-263 for proper handling procedures.

REMOVE REFERENCE OSCILLATOR

- STEP 1. Remove 3 cables ① from connectors on bottom side of reference oscillator; refer to paragraphs 3-13 and 3-14.
- STEP 2. Loosen 2 captive screws ② securing reference oscillator ③ in RT.
- STEP 3. Remove reference oscillator ③ from RT.

REPLACE REFERENCE OSCILLATOR

- STEP 1. Position reference oscillator in RT by inserting 2 locating pins into the holes provided.
- STEP 2. Tighten 2 captive screws ② securing reference oscillator ③ in RT.
- STEP 3. Connect 3 cables ① to their respective connectors on bottom of reference oscillator; refer to paragraphs 3-13 and 3-14.
- STEP 4. Replace all assemblies removed for this procedure.
- STEP 5. Replace covers.
- STEP 6. Perform BIT, (para. 3-5).

3-24. REPLACEMENT OF REFERENCE OSCILLATOR ASSEMBLY (A4) (Cont.)

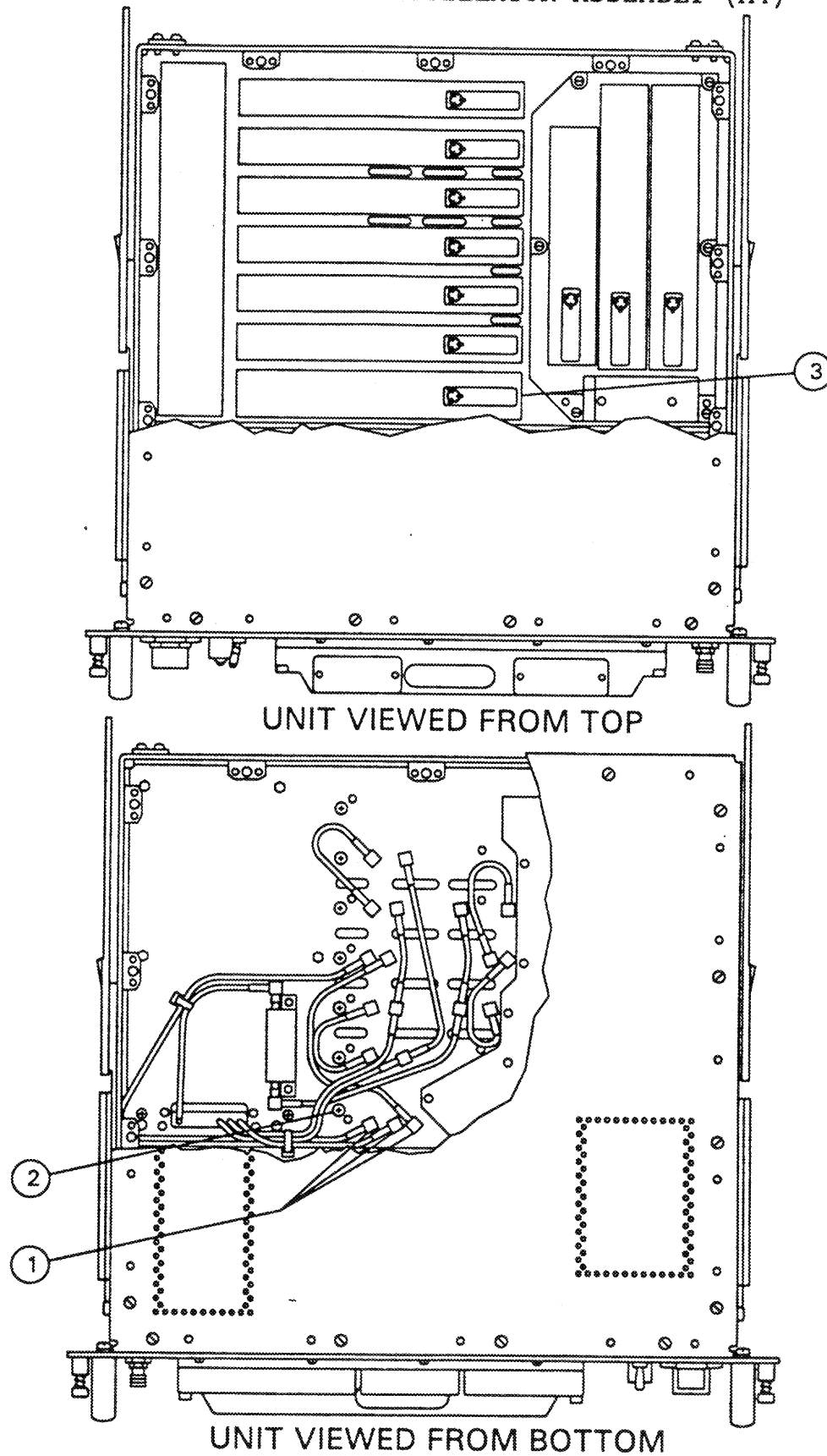

3-25. REPLACEMENT OF AUDIO SIDEBAND EXCITER ASSEMBLY (A5)

INITIAL SETUP

Tools

Tool Kit, TK-17
Workstation, Static

Equipment Condition

RT power ON switch set to OFF
RT covers removed (para. 3-12)
RT power cable disconnected

Materials/Parts

Audio Sideband Exciter Assembly, A5,
P/N A3024629

CAUTION

This equipment contains components that are sensitive to damage by ESD. Improper handling will result in component and assembly failure. Use extreme caution when handling. Refer to DOD-HDBK-263 for proper handling procedures.

REMOVE AUDIO SIDEBAND EXCITER

- STEP 1. Remove 2 cables ① from connectors on bottom side of audio sideband exciter; refer to paragraphs 3-13 and 3-14.
- STEP 2. Loosen 2 captive screws ② securing audio sideband exciter ③ in RT.
- STEP 3. Remove audio sideband exciter ③ from RT.

REPLACE AUDIO SIDEBAND EXCITER

- STEP 1. Position audio sideband exciter ③ in RT by inserting 2 locating pins into the holes provided.
- STEP 2. Tighten 2 captive screws ② securing audio sideband exciter ③ in RT.
- STEP 3. Connect 2 cables ① to their respective connectors on bottom of audio sideband exciter; refer to paragraphs 3-13 and 3-14.
- STEP 4. Replace all assemblies removed for this procedure.
- STEP 5. Replace covers.
- STEP 6. Perform BIT, (para. 3-5).

3-25. REPLACEMENT OF AUDIO SIDEBAND EXCITER ASSEMBLY (A5) (Cont.)

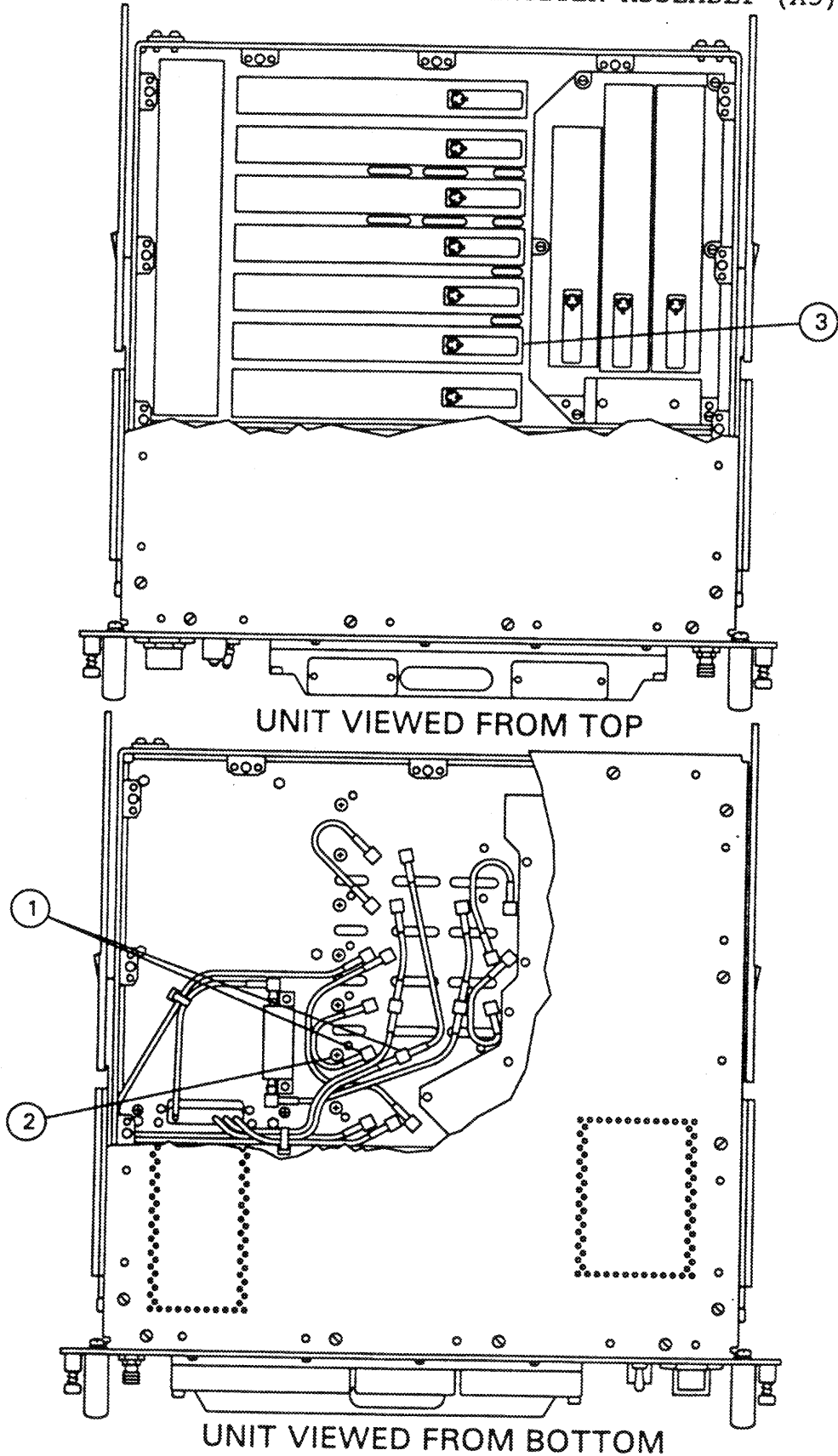

3-26. REPLACEMENT OF RF AMPLIFIER EXCITER ASSEMBLY (A6)

INITIAL SETUP

Tools

Tool Kit, TK-17
Workstation, Static

Equipment Condition

RT power ON switch set to OFF
RT covers removed (para. 3-12)
RT power cable disconnected

Materials/Parts

RF Amplifier Exciter Assembly, A6,
P/N A3024634

CAUTION

This equipment contains components that are sensitive to damage by ESD. Improper handling will result in component and assembly failure. Use extreme caution when handling. Refer to DOD-HDBK-263 for proper handling procedures.

REMOVE RF AMPLIFIER EXCITER

- STEP 1. Remove 4 cables ① from connectors on bottom side of RF amplifier exciter; refer to paragraphs 3-13 and 3-14.
- STEP 2. Loosen 2 captive screws ② securing RF amplifier exciter ③ in RT.
- STEP 3. Remove RF amplifier exciter ③ from RT.

REPLACE RF AMPLIFIER EXCITER

- STEP 1. Position RF amplifier exciter ③ in RT by inserting 2 locating pins into the holes provided.
- STEP 2. Tighten 2 captive screws ② securing RF amplifier exciter ③ in RT.
- STEP 3. Connect 4 cables ① to their respective connectors on bottom of RF amplifier exciter; refer to paragraphs 3-13 and 3-14.
- STEP 4. Replace all assemblies removed for this procedure.
- STEP 5. Replace covers.
- STEP 6. Perform BIT, (para. 3-5).

3-26. REPLACEMENT OF RF AMPLIFIER EXCITER ASSEMBLY (A6) (Cont.)

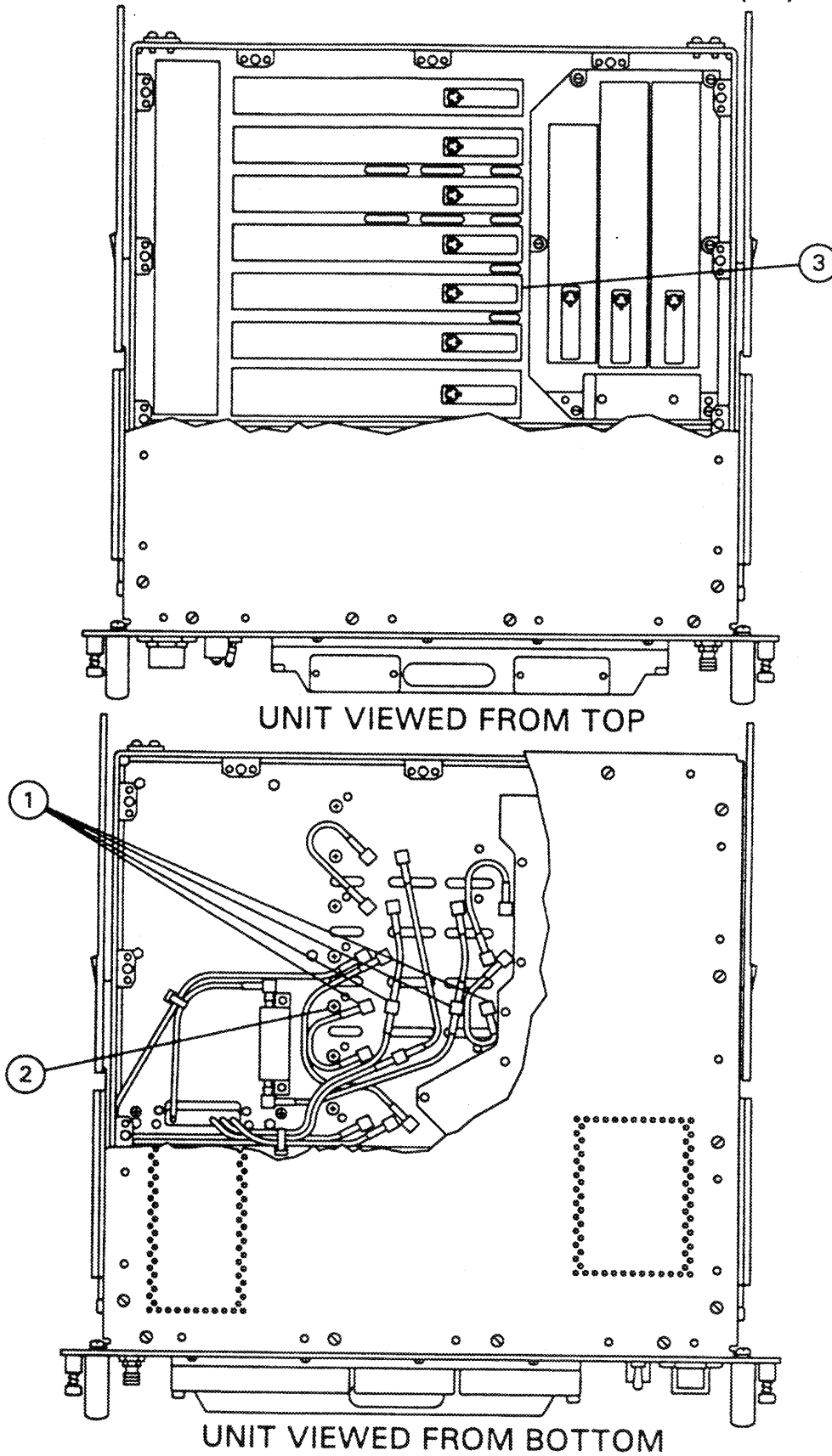

3-27. REPLACEMENT OF RF SWITCH ASSEMBLY (A7)

INITIAL SETUP

Tools

Tool Kit, TK-17
Workstation, Static

Equipment Condition

RT power ON switch set to OFF
RT covers removed (para. 3-12)
RT power cable disconnected

Materials/Parts

RF Switch Assembly, A7, P/N A3024649

CAUTION

This equipment contains components that are sensitive to damage by ESD. Improper handling will result in component and assembly failure. Use extreme caution when handling. Refer to DOD-HDBK-263 for proper handling procedures.

REMOVE RF SWITCH

- STEP 1. Remove 4 cables ① from connectors on bottom side of RF switch; refer to paragraphs 3-13 and 3-14.
- STEP 2. Loosen 2 captive screws ② securing RF switch ③ in RT.
- STEP 3. Remove RF switch ③ from RT.

REPLACE RF SWITCH

- STEP 1. Position RF switch ③ in RT by inserting 2 locating pins into the holes provided.
- STEP 2. Tighten 2 captive screws ② securing RF switch ③ in RT.
- STEP 3. Connect 4 cables ① to their respective connectors on bottom of RF switch; refer to paragraphs 3-13 and 3-14.
- STEP 4. Replace all assemblies removed for this procedure.
- STEP 5. Replace covers.
- STEP 6. Perform BIT, (para. 3-5).

3-27. REPLACEMENT OF RF SWITCH ASSEMBLY (A7) (Cont.)

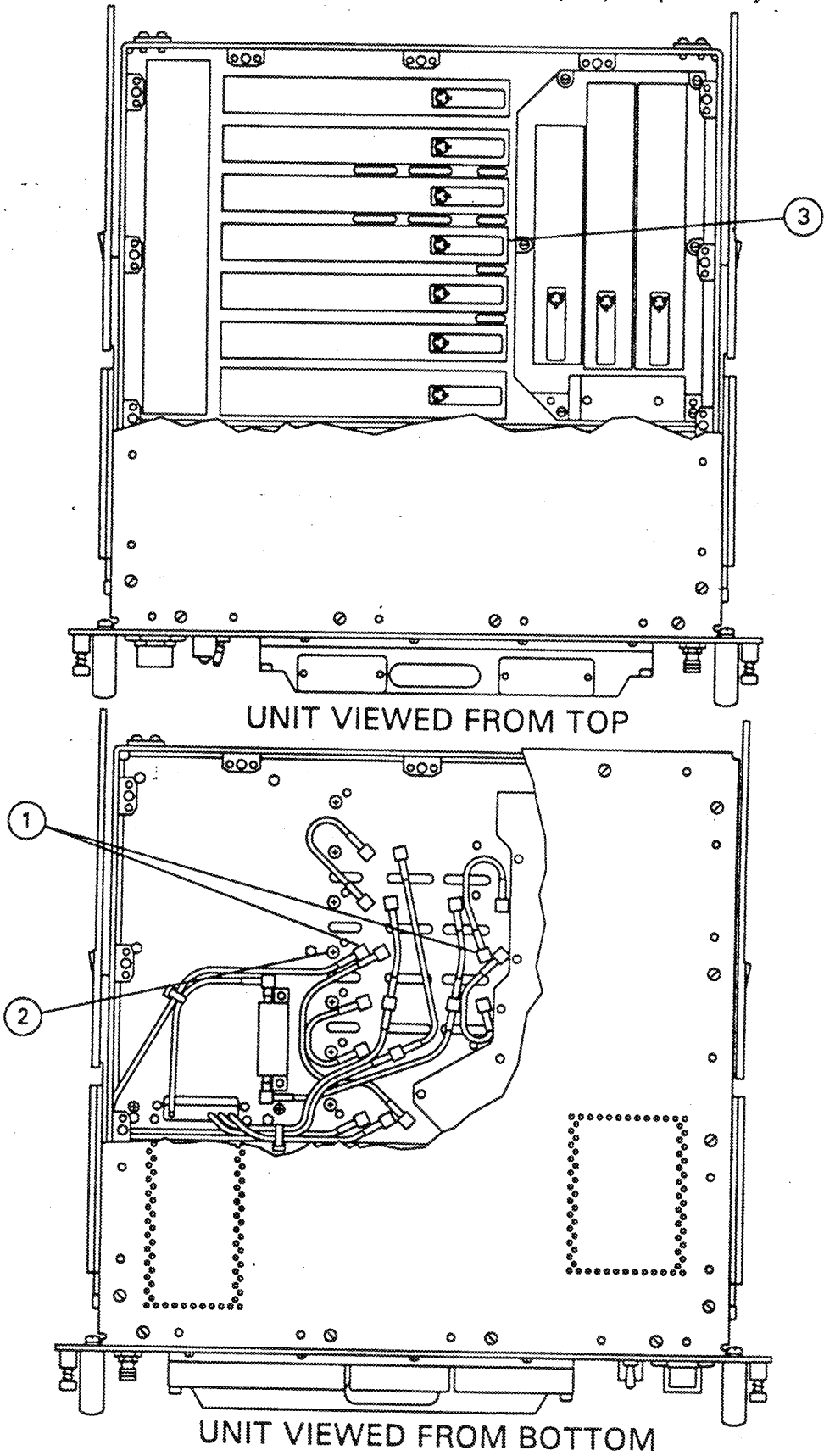

3-29. REPLACEMENT OF IF RECEIVER ASSEMBLY (A9)

INITIAL SETUP

Tools

Tool Kit, TK-17
Workstation, Static

Equipment Condition

RT power ON switch set to OFF
RT covers removed (para. 3-12)
RT power cable disconnected

Materials/Parts

IF Receiver Assembly, A9, P/N A3024639

CAUTION

This equipment contains components that are sensitive to damage by ESD. Improper handling will result in component and assembly failure. Use extreme caution when handling. Refer to DOD-HDBK-263 for proper handling procedures.

REMOVE IF RECEIVER

- STEP 1. Remove 2 cables ① from connectors on bottom side of IF receiver; refer to paragraphs 3-13 and 3-14.
- STEP 2. Loosen 2 captive screws ② securing IF receiver ③ in RT.
- STEP 3. Remove IF receiver ③ from RT.

REPLACE IF RECEIVER

- STEP 1. Position IF receiver ③ in RT by inserting 2 locating pins into the holes provided.
- STEP 2. Tighten 2 captive screws ② securing IF receiver ③ in RT.
- STEP 3. Connect 2 cables ① to their respective connectors on bottom of IF receiver; refer to paragraphs 3-13 and 3-14.
- STEP 4. Replace all assemblies removed for this procedure.
- STEP 5. Replace covers.
- STEP 6. Perform BIT, (para. 3-5).

3-29. REPLACEMENT OF IF RECEIVER ASSEMBLY (A9) (Cont.)

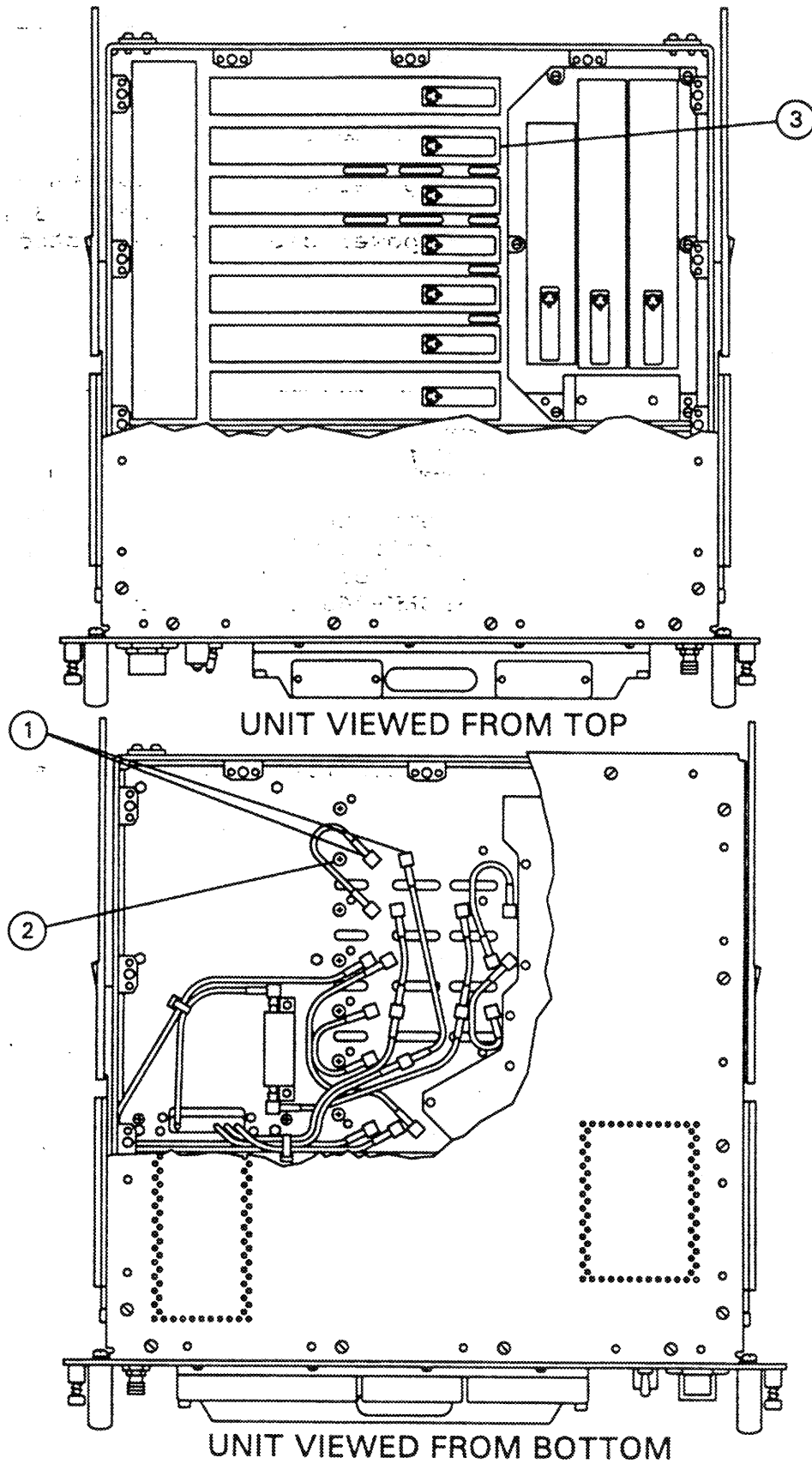

3-30. REPLACEMENT OF AUDIO RECEIVER ASSEMBLY (A10)

INITIAL SETUP

Tools

Tool Kit, TK-17
Workstation, Static

Equipment Condition

RT power ON switch set to OFF
RT covers removed (para. 3-12)
RT power cable disconnected

Materials/Parts

Audio Receiver Assembly, A10,
P/N A3024654

CAUTION

This equipment contains components that are sensitive to damage by ESD. Improper handling will result in component and assembly failure. Use extreme caution when handling. Refer to DOD-HDBK-263 for proper handling procedures.

REMOVE AUDIO RECEIVER

- STEP 1. Loosen 2 captive screws ① securing audio receiver ② in RT.
- STEP 2. Remove audio receiver ② from RT.

REPLACE AUDIO RECEIVER

- STEP 1. Position audio receiver ② in RT by inserting 2 locating pins into the holes provided.
- STEP 2. Tighten 2 captive screws ① securing audio receiver ② in RT.
- STEP 3. Replace all assemblies removed for this procedure.
- STEP 4. Replace covers.
- STEP 5. Perform BIT, (PARA. 3-5).

3-30. REPLACEMENT OF AUDIO RECEIVER ASSEMBLY (A10) (Cont.)

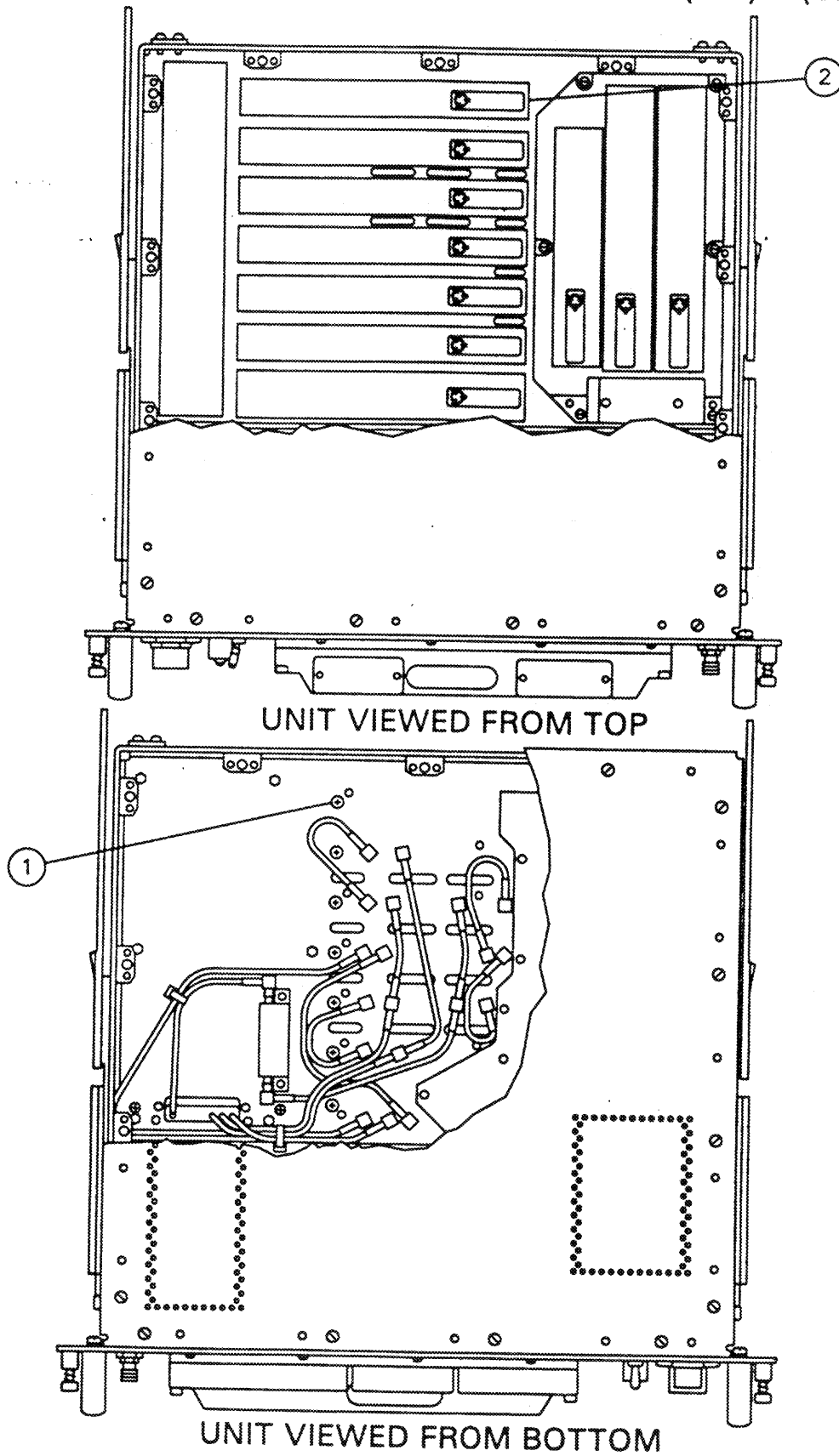

3-31. REPLACEMENT OF POWER SUPPLY (PS1)

INITIAL SETUP

Tools

Tool Kit, TK-17
Workstation, Static

Equipment Condition

RT power ON switch set to OFF
RT covers removed (para. 3-12)
RT power cable disconnected

Materials/Parts

Power Supply, PS1, P/N A3024060

CAUTION

This equipment contains components that are sensitive to damage by ESD. Improper handling will result in component and assembly failure. Use extreme caution when handling. Refer to DOD-HDBK-263 for proper handling procedures.

REMOVE POWER SUPPLY

STEP 1. Loosen 3 captive screws ① securing power supply ② in RT.

STEP 2. Remove power supply ② from RT.

REPLACE POWER SUPPLY

STEP 1. Position power supply ② in RT by inserting 2 locating pins into the holes provided.

STEP 2. Screw in and tighten 3 captive screws ① securing power supply ② in the RT.

STEP 3. Replace all assemblies removed for this procedure.

STEP 4. Replace covers.

STEP 5. Perform BIT, (PARA. 3-5).

3-31. REPLACEMENT OF POWER SUPPLY (PS1) (Cont.)

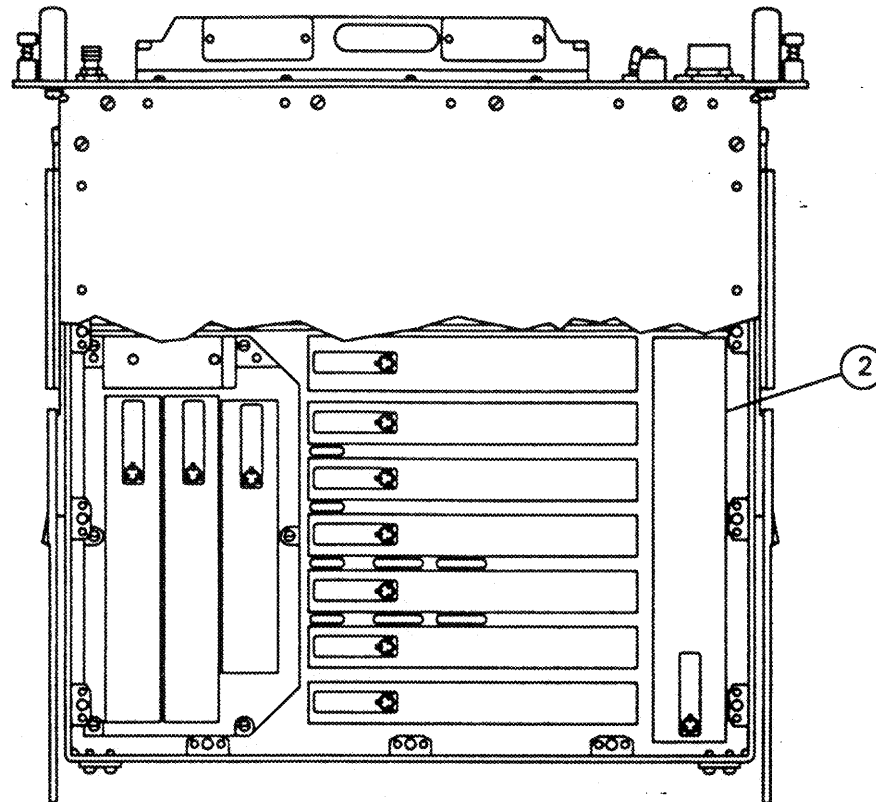

TOP VIEW COVER REMOVED

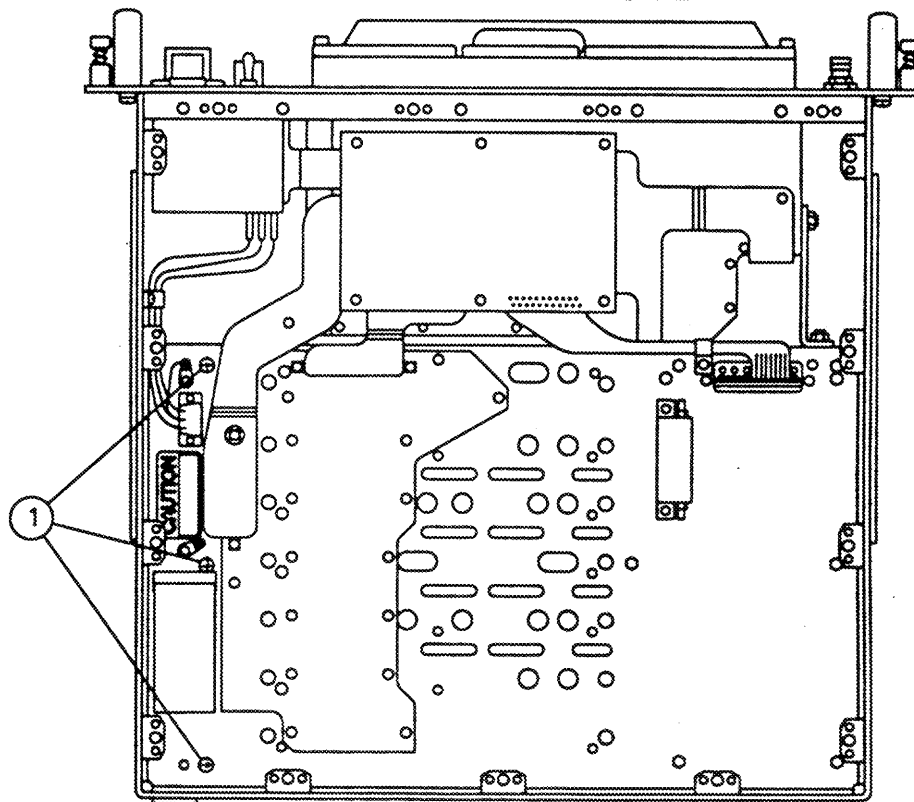

BOTTOM VIEW RT CHASSIS

3-32. DISASSEMBLY OF POWER SUPPLY (PS1)

Removal procedures for the two side covers of the PS are the same. Therefore, only one procedure, which is to be used for removal of either side cover, is provided. However, the sequence of removal of CCAs and parts from the PS dictate the left side cover must be removed in all cases and the right side cover only when the AC to DC Inverter CCA is to be removed.

INITIAL SETUP

Tools

Tool Kit, TK-17
Workstation, Static

Equipment Condition

PS removed from RT (para. 3-31)

CAUTION

This equipment contains components that are sensitive to damage by ESD. Improper handling will result in component and assembly failure. Use extreme caution when handling. Refer to DOD-HDBK-263 for proper handling procedures.

REMOVE COVER

STEP 1. Remove 4 screws ① from left cover ②.

NOTE

Left cover is the side having the air holes towards the bottom of the PS, where the locating pins are.

STEP 2. Remove cover from PS.

REPLACE COVER

STEP 1. Position cover ② on PS ③.

STEP 2. Secure cover with four mounting screws ①.

3-32. DISASSEMBLY OF POWER SUPPLY (PS1) (Cont.)

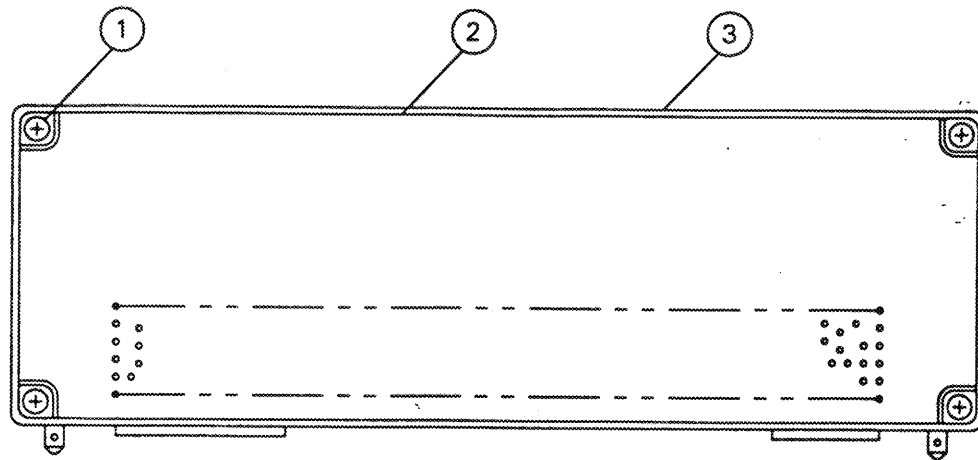

PS LEFT SIDE VIEW

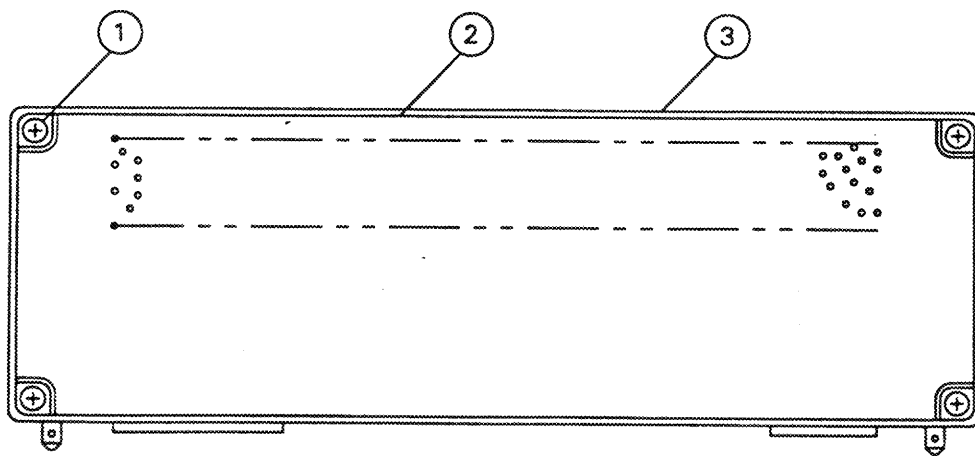

PS RIGHT SIDE VIEW

3-33. REPLACEMENT OF PS REGULATOR OUTPUT CCA (PS1A3)

INITIAL SETUP

Tools

Tool Kit, TK-17
Workstation, Static

Equipment Condition

PS removed from RT (para. 3-31)
PS left cover removed,
(para. 3-32)

Material/Parts

PS Regulator Output CCA, PS1A3,
P/N A3028133

CAUTION

This equipment contains components that are sensitive to damage by ESD. Improper handling will result in component and assembly failure. Use extreme caution when handling. Refer to DOD-HDBK-263 for proper handling procedures.

REMOVE PS REGULATOR OUTPUT CCA

- STEP 1. Remove 6 screws with flatwashers ① securing regulator output CCA ② in power supply.
- STEP 2. Tilt the regulator output CCA out at the top and down for access to flexible cable connectors W1P1 and W2P1.
- STEP 3. Disconnect flexible cable connectors W1P1 ③ and W2P1 ④ at the AC to DC inverter CCA ⑤.
- STEP 4. Remove regulator output CCA ② from power supply.

REPLACE PS REGULATOR OUTPUT CCA

- STEP 1. Position bottom side of regulator output CCA ② next to PS with flexible cable connectors in position to make connections to the AC to DC inverter CCA ⑤.
- STEP 2. Connector flex cable connectors W1P1 ③ and W2P1 ④ to connectors on AC to DC inverter CCA ⑤.
- STEP 3. Position regulator output CCA in PS and secure with 6 screws and flatwashers ①.

3-33. REPLACEMENT OF PS REGULATOR OUTPUT CCA (PS1A3) (Cont.)

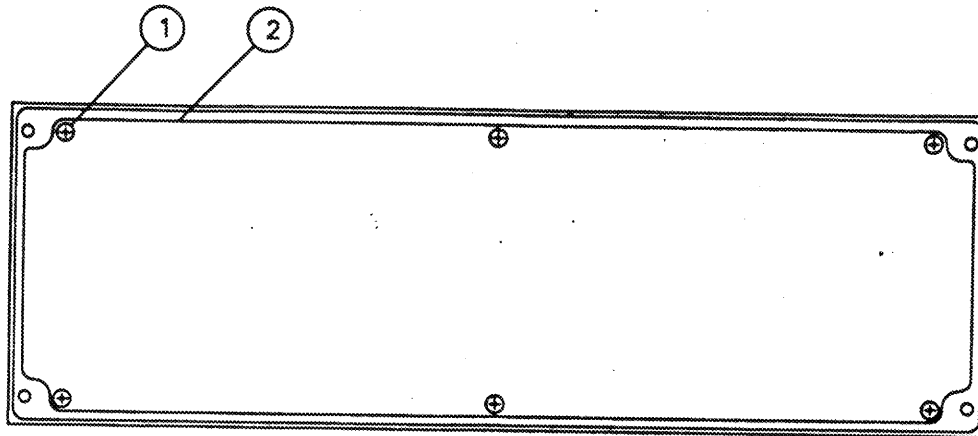

PS LEFT SIDE VIEW WITH COVER REMOVED

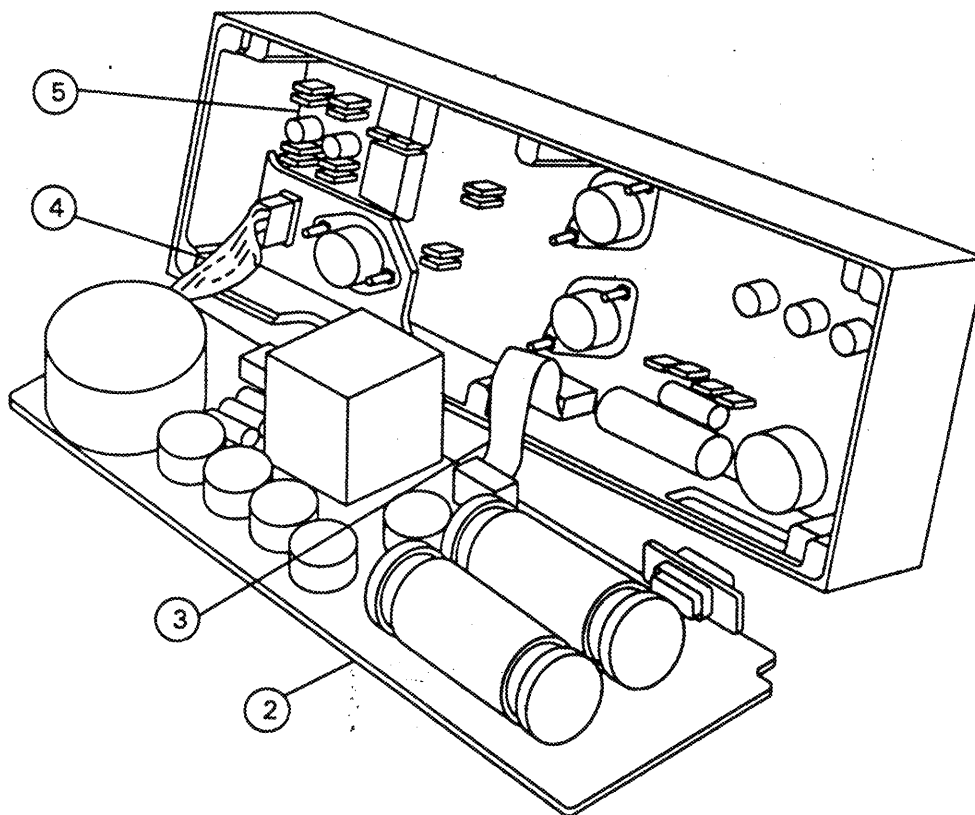

STEP 4. Perform PS functional test (paragraph 3-10a) to verify the power supply is operational.

STEP 5. Replace left side covers, (para. 3-32).

3-34. REPAIR OF PS REGULATOR OUTPUT CCA (PS1A3)

INITIAL SETUP

Tools

Tool Kit, TK-17
Maintenance Kit, MX-10897/G
Repair Kit, MK-772/U
Workstation, Static

Equipment Condition

PS removed from RT (para. 3-31)
PS left cover removed,
(para. 3-32)
PS regulator output CCA removed,
(para. 3-33)

Materials/Parts

Replacement Component, Refer to:
(Army) TM 11-5895-1303-24P
(Navy) EE162-NG-PLD-010/W110-RT1512G
(Air Force) TO 31R2-2-562-4

CAUTION

This equipment contains components that are sensitive to damage by ESD. Improper handling will result in component and assembly failure. Use extreme caution when handling. Refer to DOD-HDBK-263 for proper handling procedures.

STEP 1. Perform fault isolation to defective component, (para. 3-10).

NOTE

Fault isolation to the defective component is accomplished with the CCA installed in the chassis assembly.

STEP 2. Remove and replace defective component using standard soldering techniques.

STEP 3. Replace all assemblies removed for this procedure.

STEP 4. Perform PS functional test, (para. 3-10).

3-35. REPLACEMENT OF PS CHASSIS MOUNTED REGULATOR (PS1A1U1)

INITIAL SETUP

Tools

Tool Kit, TK-17
Maintenance Kit, MX-10897/G
Repair Kit, MK-772/U
Workstation, Static

Equipment Condition

PS removed from RT (para. 3-31)
PS left cover removed,
(para. 3-32)
PS regulator output CCA removed,
(para. 3-33)

Materials/Parts

IC, Desc (Regulator), PS1A1U1, P/N 7703401YX
Insulator, Regulator, P/N A3028706-1

CAUTION

When replacing this regulator, be sure to replace the insulator in the proper position.

CAUTION

This equipment contains components that are sensitive to damage by electrostatic discharge (ESD). Improper handling will result in component and assembly failure. Use care when handling. Refer to DOD-HDBK-263 for proper handling procedures.

REMOVE CHASSIS MOUNTED REGULATOR

STEP 1. Remove 2 nuts with starwashers ①.

STEP 2. Lift regulator ② out of chassis.

3-35. REPLACEMENT OF PS CHASSIS MOUNTED REGULATOR (PS1A1U1) (Cont.)

REPLACE CHASSIS MOUNTED REGULATOR

- STEP 1. Place regulator ② and insulator in proper location on chassis.
- STEP 2. Install 2 nuts with starwashers ①.
- STEP 3. Perform PS function test (paragraph 3-10a) to verify the power supply is operational.
- STEP 4. Replace all assemblies removed for this procedure.

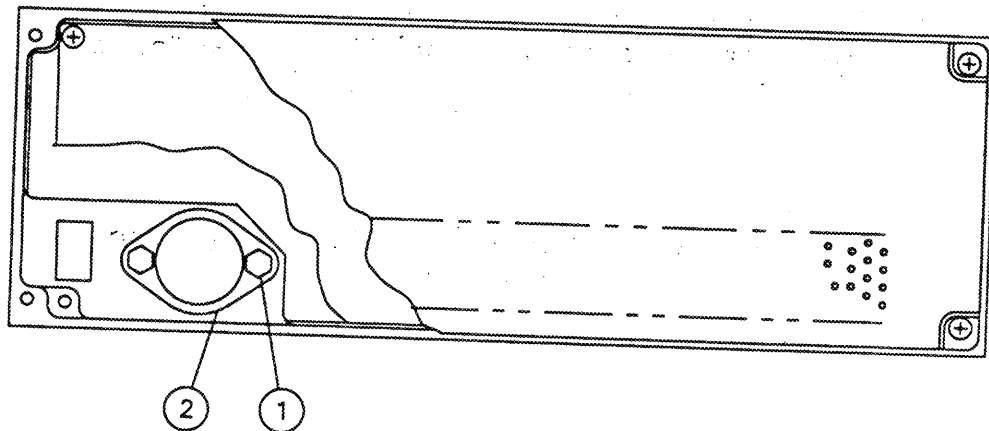

PS CUTAWAY VIEW OF
LEFT SIDE SHOWING REGULATOR

3-36. REPLACEMENT OF PS AC TO DC INVERTER CCA (PS1A2)

INITIAL SETUP

Tools

Tool Kit, TK-17
Workstation, Static

Materials/Parts

PS AC to DC Inverter, PS1A2,
P/N A3024341

Equipment Condition

PS removed from RT (para. 3-31)
PS left cover removed,
(para. 3-32)
PS regulator output CCA removed,
(para. 3-33)
PS chassis mounted regulator
removed, (para. 3-35)

CAUTION

This equipment contains components that are sensitive to damage by electrostatic discharge (ESD). Improper handling will result in component and assembly failure. Use extreme caution when handling. Refer to DOD-HDBK-263 for proper handling procedures.

REMOVE PS AC TO DC INVERTER CCA

- STEP 1. Remove 6 screws with washers ① securing AC to DC inverter CCA ② in power supply.
- STEP 2. Remove AC to DC inverter CCA ② from power supply.

3-36. REPLACEMENT OF PS AC TO DC INVERTER CCA (PS1A2) (Cont.)

REPLACE PS AC TO INVERTER CCA

- STEP 1. Position AC to DC inverter CCA (2) in power supply.
- STEP 2. Position and screw in 6 screws with washers (1) securing AC to DC inverter CCA (2) in power supply.
- STEP 3. Perform PS function test (paragraph 3-10a) to verify the power supply is operational.
- STEP 4. Replace left side cover, (para. 3-32).

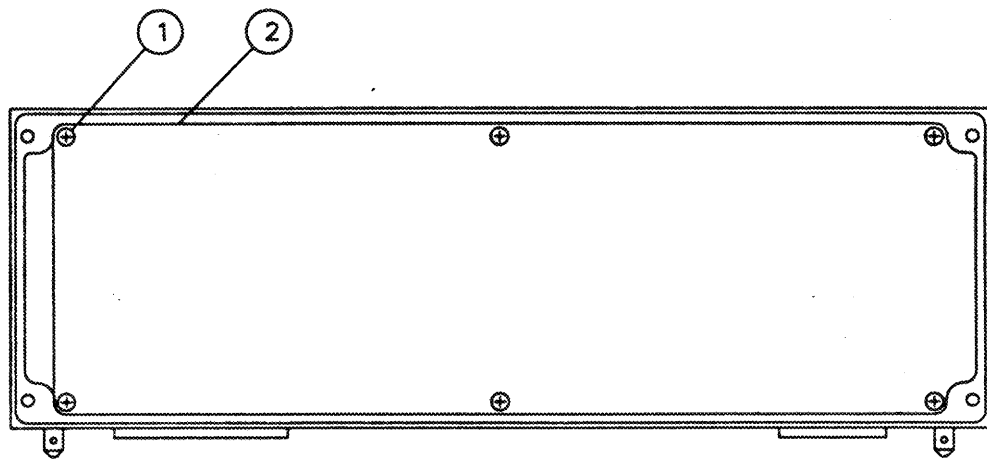

PS RIGHT SIDE VIEW COVER REMOVED
AC TO DC INVERTER SIDE

3-37. REPAIR OF PS AC TO DC INVERTER CCA (PS1A2)

INITIAL SETUP

Tools

Tool Kit, TK-17
Repair Kit, PCB MK-772/U
Maintenance Kit, MX-10897/G

Equipment Condition

PS removed from RT (para. 3-31)
PS AC to DC inverter removed,
(para. 3-36)

Material/Parts

Replacement Component, Refer to:
(Army) TM 11-5895-1303-24P
(Navy) EE162-NG-PLD-010/W110-RT1512G
(Air Force) TO 31R2-4-562-4

CAUTION

This equipment contains components that are sensitive to damage by electrostatic discharge (ESD). Improper handling will result in component and assembly failure. Use extreme caution when handling. Refer to DOD-HDBK-263 for proper handling procedures.

STEP 1. Perform fault isolation to defective component, (para. 3-10).

NOTE

Fault isolation to the defective component is accomplished with the CCA installed in the chassis assembly.

STEP 2. Remove and replace defective component using standard soldering techniques.

STEP 3. Replace all assemblies removed for this procedure.

STEP 4. Perform PS functional test, (para. 3-10).

APPENDIX A REFERENCES

A-1. SCOPE

This appendix lists all technical manuals and publications which are referenced in this manual or that contain information applicable to the operation and maintenance of the Receiver-Transmitter RT-1512/G.

A-2. PUBLICATIONS

- Consolidated Index of Army Publications
and Blank Forms DA Pam 25-30
- Expendable Items (Except Medical, Class V, Repair
Parts, and Heraldic Items) CTA 50-970
- Installation Practices: Communication Systems
Grounding, Bonding, and Shielding FM 11-487-4/TO 31-10-24
- Issue of Ships Maintenance and Material Managements
(3-M) Manual OPNAVINST 4790.4a
- Maintenance Data Collection System AFM 66-267
- Naval Supply Publication 2002 Navy Stock List of
Publications and Forms NAVSUP 2002
- Operator's and Unit Maintenance Manual
for Communications terminal AN/TRC-179(V)1
(NSN 5895-01-156-0411) TM 11-5895-1218-12
EE150-LQ-OMI-010/W110-TRC179V1/
TO 31R2-2TRC179-21
- Operator's and Unit Maintenance Manual
for Communications Terminal, AN/TRC-179(V)2,
(NSN 5895-01-156-0412) TM 11-5895-1219-12/
EE150-LR-OMI-010/W110-TRC179V1/
TO 31R2-2TRC179-1

A-3. REFERENCES

- Preservation, Packaging, and Packing of Military
Supplies and Equipment Volume 2 NAVSUP PUB 503

Procedures for Destruction of Electronics Materiel
to Prevent Enemy Use (Electronics Command) TM 750-244-2

Release for Shipment of Ground Communication
Electronic Cryptographic Equipment AFR 67-31

Report of Discrepancy Report (ROD) SECNAVINST 4355.18

Transportation Discrepancy Report (TRD) NAVSUPINST 4610.33C

The Army Maintenance Management System (TAMMS) DA Pam 738-750

Unit, Intermediate Direct Support and General
Support Maintenance Repair Parts and Special
Tools List (Including Depot Maintenance Repair
Parts and Special Tools List) for Receiver-
Transmitter RT-1512/G TM 11 5895-1303-24P/
EE162-NG-PLD-010/W110-RT1512G/
TO 31R2-4-562-4

Unit, Intermediate Direct Support and General
Support Maintenance Manual for Controller,
Receiver-Transmitter C-11670/G TM 11-5895-1315-24/
EE005-FG-MMI-010/W110-C11670G/
TO-31R2-4-567-2

Unit, Intermediate Direct Support and
General Support Maintenance Repair
Parts and Special Tools List
(Including Depot Maintenance Repair
Parts and Special Tools Lists) for
Test Set, Power Supply TS-4244/G
(NSN 6625-01-267-4417)
TM 11-6625-3215-14&P/
ET940-AB-OMP-010/TS4244G/
TO 33AA17-192-1

APPENDIX B MAINTENANCE ALLOCATION CHART

Section I. INTRODUCTION

B-1. GENERAL

This appendix provides a summary of the maintenance operations for the Power Supply PP-8095/G. It authorizes levels of maintenance for specific maintenance functions on repairable items and components and the tools and equipment required to perform each function. This appendix may be used as an aid in planning maintenance operations.

B-2. MAINTENANCE FUNCTION

Maintenance functions will be limited to and defined as follows:

a. Inspect. To determine the serviceability of an item by comparing its physical, mechanical, and/or electrical characteristics with established standards through examination.

b. Test. To verify serviceability and to detect incipient failure by measuring the mechanical or electrical characteristics of an item and comparing those characteristics with prescribed standards.

c. Service. Operations required periodically to keep an item in proper operating condition, i.e., to clean (decontaminate), to preserve, to drain, to paint, or to replenish fuel, lubricants, hydraulic fluids, or compressed air supplies.

d. Adjust. To maintain, within prescribed limits, by bringing into proper or exact position, or by setting the operating characteristics to the specified parameters.

e. Align. To adjust specified variable elements of an item to bring about optimum or desired performance.

f. Calibrate. To determine and cause corrections to be made or to be adjusted on instruments or test measuring and diagnostic equipment used in precision measurement. Consists of comparisons of two instruments, one of which is a certified standard of known accuracy, to detect and adjust any discrepancy in the accuracy of the instrument being compared.

g. Install. The act of emplacing, seating, or fixing into position an item, part, module (component or assembly) in a manner to allow the proper functioning of the equipment or system.

h. Replace. The act of substituting a serviceable like type part, subassembly, or module (component or assembly) for an unserviceable counterpart.

i. Repair. The application of maintenance services (inspect, test, service, adjust, align, calibrate, replace) or other maintenance actions (welding, grinding, riveting, straightening, facing, remachining, or resurfacing) to restore serviceability to an item by correcting specific damage, fault, malfunction, or failure in a part, subassembly, module (component or assembly), end item, or system.

j. Overhaul. That maintenance effort (service/action) necessary to restore an item to a completely serviceable/operational condition as prescribed by maintenance standards (i.e., DMWR) in appropriate technical publications. Overhaul is normally the highest degree of maintenance performed by the Army. Overhaul does not normally return an item to like new condition.

k. Rebuild. Consists of those services/action necessary for the restoration of unserviceable equipment to a like new condition in accordance with original manufacturing standards. Rebuild is the highest degree of materiel maintenance applied to Army equipment. The rebuild operation includes the act of returning to zero those age measurements (hours, miles, etc.) considered in classifying Army equipments/components.

B-3. COLUMN ENTRIES

a. Column 1, Group Number. Column 1 lists group numbers, the purpose of which is to identify components, assemblies, subassemblies, and modules with the next higher assembly.

b. Column 2, Component/Assembly. Column 2 contains the noun names of components, assemblies, subassemblies, and modules for which maintenance is authorized.

c. Column 3, Maintenance Functions. Column 3 lists the functions to be performed on the item listed in column 2. When items are listed without maintenance functions, it is solely for purpose of having the group numbers in the MAC and RPSTL coincide.

d. Column 4, Maintenance Level. Column 4 specifies, by the listing of a work time figure in the appropriate subcolumn(s), the lowest level of maintenance authorized to perform the function listed in column 3. This figure represents the active time required to perform that maintenance function at the indicated level of maintenance. If the number or complexity of the tasks within the listed maintenance function vary at different maintenance levels, appropriate work time figures will be shown for each category. The number of task-hours specified by the work time figure represents the average time required to restore an item (assembly, subassembly, component, module, end item, or system) to a serviceable condition under typical field operating conditions. This time includes preparation time, troubleshoot-

ing time, and quality assurance/quality control time in addition to the time required to perform the specific tasks identified for the maintenance functions authorized in the maintenance allocation chart. Subcolumns of column 4 are as follows:

UNIT

- C - Operator/Crew
- O - Organizational/Unit

INTERMEDIATE

- F - Direct Support
- H - General Support
- L - Special Repair Activity (SRA)

DEPOT

- D - Depot

e. Column 5, Tools and Equipment. Column 5 specifies by code, those common tool sets (not individual tools) and special tools, test, and support equipment required to perform the designated function.

f. Column 6, Remarks. Column 6 contains an alphabetic code which leads to the remark in section IV, Remarks, which is pertinent to the item opposite the particular code.

B-4. TOOL AND TEST EQUIPMENT REQUIREMENTS (SECT. III)

a. Tool or Test Equipment Reference Code. The numbers in this column coincide with the numbers used in the tools and equipment column of the MAC. The numbers indicate the applicable tool or test equipment for the maintenance functions.

b. Maintenance Level. The codes in this column indicate the maintenance level allocated to tool or test equipment.

c. Nomenclature. This column lists the noun name and nomenclature of the tools and test equipment required to perform the maintenance functions.

d. National/NATO Stock Number. This column lists the National/NATO stock number of the specific tool or test equipment.

e. Tool Number. This column lists the manufacturer's part number of the tool followed by the Federal Supply Code for manufacturers (5-digit) in parentheses.

B-5. REMARKS (SECT. IV)

a. Reference Code. This code refers to the appropriate item in section II, column 6.

b. Remarks. This column provides the required explanatory information necessary to clarify items appearing in section II.

SECTION II. MAINTENANCE ALLOCATION CHART
FOR
RECEIVER-TRANSMITTER RT-1512/G

(1) GROUP NUMBER	(2) COMPONENT/ASSEMBLY	(3) MAINT. FUNCTION	(4) MAINTENANCE LEVEL					(5) TOOLS AND EQPT.	(6) REMARKS		
			UNIT		INTERMEDIATE		DEPOT				
			C	O	F	H	D				
00	RECEIVER-TRANSMITTER RT-1512/G (A3023756)	REPLACE TEST REPAIR TEST REPAIR OVERHAUL		0.1 0.1 0.1					1 1,2,16 3-11 7,12-15 TBD	A,G B,F,G C,F D,F	
01	CHASSIS ASSEMBLY A1 (A3024604)	TEST REPAIR						1.0 1.0	3,7,8 7,13,14	G G,H	
0101	MODULE INTERCONNECT CCA A1A1 (A3024659)	REPLACE REPAIR						0.2 L(1.0)	7,13 7,12,15	E,K	
0102	PRINTED CABLE ASSEMBLY, FLEXIBLE INTERCONNECT A1W3 (A3024609)	REPLACE TEST REPAIR						0.2 L(0.5) L(1.0)	7,13 3,8 12,15	E E	
02	CONTROLLER, RT C-11670/G A2 (A3023813)	REPLACE REPAIR		0.1					2,16	A,F J	
03	FREQUENCY SYNTHESIZER A3 (A3024340)	REPLACE TEST REPAIR						0.2	7,13 TBD 2.0 TBD	F L L	
0301	LOOP 1/SUM LOOP 1 ASSY A3A1 (A3024344)	REPAIR							2.0	G	
030101	LOOP 1 CCA A3A1A1 (A3024346)	TEST REPAIR							1.0 1.0	TBD TBD	F F
030102	SUM LOOP 1 CCA A3A1A2 (A3024350)	TEST REPAIR							1.0 1.0	TBD TBD	F F
0302	LOOP 2/SUM LOOP 2 ASSY A3A2 (A3024354)	REPAIR							2.0	G	
030201	LOOP 2 CCA A3A2A1 (A3024356)	TEST REPAIR							1.0 1.0	TBD TBD	F F
030202	SUM LOOP 2 CCA A3A2A2 (A3024360)	TEST REPAIR							1.0 1.0	TBD TBD	F F
0303	LOOP 3/REF. ASSEMBLY A3A3 (A3024364)	REPAIR							2.0	G	
030301	LOOP 3 CCA A3A3A1 (A3024366)	TEST REPAIR							1.0 1.0	TBD TBD	F F
030302	REFERENCE CCA A3A3A2 (A3024370)	TEST REPAIR							1.0 1.0	TBD TBD	F F
0304	CHASSIS/REGULATOR ASSY A3A4 (A3024374)	TEST REPAIR							0.5 1.0	3,4,8 13	M
04	REFERENCE OSCILLATOR ASSEMBLY A4 (A3024618)	REPLACE TEST REPAIR						0.2	1.5 1.0	7,13 TBD TBD	F F,L F,L,N

SECTION II. MAINTENANCE ALLOCATION CHART
FOR
RECEIVER-TRANSMITTER RT-1512/G (Continued)

(1) GROUP NUMBER	(2) COMPONENT/ASSEMBLY	(3) MAINT. FUNCTION	(4) MAINTENANCE LEVEL					(5) TOOLS AND EQPT.	(6) REMARKS
			UNIT		INTERMEDIATE		DEPOT		
			C	O	F	H	D		
0401	REFERENCE OSCILLATOR CCA A4A1 (A3024621)	TEST REPAIR					1.0 1.0	TBD TBD	F F
0402	STATUS CCA A4A2 (A3024625)	TEST REPAIR					1.0 1.0	TBD TBD	F F
05	AUDIO SIDEBAND EXCITER ASSEMBLY A5 (A3024629)	REPLACE TEST REPAIR				0.1 L(1.0) L(1.0)	7, 13 TBD TBD	F E, F E, F, N	
0501	AUDIO SIDEBAND EXCITER CCA A5A1 (A3024630)	REPAIR				L(1.0)		G	
06	RF AMP EXCITER ASSEMBLY A6 (A3024634)	REPLACE TEST REPAIR				0.1 L(1.0) L(1.0)	7, 13 TBD TBD	F E, F E, F, N	
0601	RF AMP EXCITER CCA A6A1 (A3024635)	REPAIR				L(1.0)		G	
07	RF SWITCH ASSEMBLY A7 (A3024649)	REPLACE TEST REPAIR				0.1 L(1.5) L(1.0)	7, 13 TBD TBD	F E, F E, F, N	
0701	RF SWITCH CCA A7A1 (A3024650)	REPAIR				L(1.0)		G	
08	RF RECEIVER ASSEMBLY A8 (A3024644)	REPLACE TEST REPAIR				0.1 L(1.5) L(1.0)	7, 13 TBD TBD	F E, F E, F, N	
0801	RF RECEIVER CCA A8A1 (A3024645)	REPAIR				L(1.0)		G	
09	IF RECEIVER ASSEMBLY A9 (A3024639)	REPLACE TEST REPAIR				0.1 L(1.5) L(1.0)	7, 13 TBD TBD	F E, F E, F, N	
0901	IF RECEIVER CCA A9A1 (A3024640)	REPAIR				L(1.0)		G	
10	AUDIO RECEIVER ASSEMBLY A10 (A3024654)	REPLACE TEST REPAIR				0.1 L(1.0) L(1.0)	7, 13 TBD TBD	F E, F E, F, N	
1001	AUDIO RECEIVER CCA A10A1 (A3024655)	REPAIR				L(1.0)		G	
11	POWER SUPPLY ASSEMBLY PS1 (A3024060)	TEST REPAIR				1.0 1.0	3, 4, 6-11 7, 12, 13, 15	F F, N	
1101	AC TO DC INVERTER CCA PS1A2 (A3024841)	REPAIR				1.0		G	
1102	REGULATOR OUTPUT CCA PS1A3 (A3028133)	REPAIR				1.0		G	

SECTION III TOOL AND TEST EQUIPMENT REQUIREMENTS
FOR

RECEIVER-TRANSMITTER RT-1512/G

TOOL OR TEST EQUIPMENT REF CODE	MAINTENANCE LEVEL	NOMENCLATURE	NATIONAL/NATO STOCK NUMBER	TOOL NUMBER
1	O	TOOL KIT TK-101/G	5180-00-064-5178	
2	O	KEY SET, SOCKET HEAD	5120-00-112-9599	
3	H	MULTIMETER, DIGITAL AN/USM-486	6625-01-145-2430	FLUKE 8050A-01
4	H	OSCILLOSCOPE AN/USM-488	6625-01-187-7847	TEK 2235L
5	H	CABLE ASSEMBLY, POWER, ELECT. CX-13361/G	5995-01-263-4594	MX 569709-801
6	H	TEST SET, POWER SUPPLY TS-4244/G	6625-01-267-4417	MX 950585-801
7	H	WORKSTATION, STATIC	4940-01-087-3458	3M 8021
8	H	KIT, TEST LEAD (FOR FLUKE)	6625-00-444-4041	
9	H	POWER SUPPLY PP-8202/G *	6130-00-160-0827	HP 6274B
10	H	SHUNT, CURRENT (0.01 Ohm)	6625-01-093-4609	FLUKE 80J-10
11	H	ACTIVE LOAD	6625-01-111-3363	ACDC EL 750B
12	H	MAINTENANCE KIT, PCB MX-10897/G	5895-01-267-9473	PACE MODEL RNR P/N 8007-0117
13	H	TOOL KIT, ELECT. TK-17 (INCL. METRIC)	5180-01-195-0855	JENSEN JTK-17RM
14	H	REMOVER, ELECTRICAL CONTACT	5120-00-176-9297	ITT CANNON CET-C6B
15	H	REPAIR KIT, PCB MK-772/U	5999-00-757-7042	
16	O	STATIC CONTROL SERVICE KIT	6625-01-168-2044	3M 8501

* PP-8214/G (NSN 6130-00-150-0028) PROVIDES IDENTICAL CAPABILITY WHEN SOURCE POWER IS 230V, 50 CYCLE. AIR FORCE USE ONLY.

Section II. EXPENDABLE SUPPLIES AND MATERIALS LIST

(1) NUMBER	(2) LEVEL	(3) NATIONAL STOCK NUMBER	(4) DESCRIPTION	(5) U/M
1	O,H	8305-00-267-1689	Cloth, Cheesecloth: Cotton; lintless; bleached; 36 in.; (CCC-C-440, Type II Class 2 81348) In Tool Kit TK-101/G	yd
2	O,H	8020-00-245-4509	Brush; paint; squirrel hair bristles; sq. edge; 1 in. wd; M-B-391 (81348) In Tool Kit TK-101/G	Ea
3	O	7930-01-055-6121	Detergent GP, Liquid	gal
4	H	8030-00-155-6444	Antiseize Compound MIL-A-907	oz
5	H	5975-00-727-5153	Cable straps (tie-down) B96906 MS3367-4-9	Ea
6	H	5975-00-074-2072	Cable straps (tie-down) MS3367-1-9	Ea

GLOSSARY

Section I. ABBREVIATIONS AND ACRONYMS

A

A Amper
AC Alternating Current
AFC Automatic Frequency Control
AGC Automatic Gain Control
ALE Address Latch Enable
ALU Arithmetic Logic Unit
AM Amplitude Modulation
AMP Amplifier
AMPS Ampere
ASCII American Standard for Information Interchange
ASSY Assembly
ATU Antenna Tuning Unit

B

BIT Built In Test
BITE Built In Test Equipment
BPS Bits Per Second, or Bytes Per Second
BW Bandwidth

C

CB Circuit Breaker
CCA Circuit Card Assembly
CCW Counter-clockwise
CIU Control Interface Unit
CLK Clock
COMSEC Communication Security
CPU Central Processor Unit
CTS Clear to Send
CuP Crypto MicroProcessor
CW Continuous Wave
CW Clockwise

D

dB Decibels
DC Direct Current
D/K Display Keypad Unit
DCE Data Communication Equipment
DMA Direct Memory Access
DMM Digital Multimeter
DSR Data Set Ready
DTR Data Terminal Ready
DT/R Data Transmit/Receive
DTE Data Terminal Equipment

DATA COMMUNICATION - The interchange of data messages from one point to another over communications channels.

DATA COMMUNICATION EQUIPMENT (DCE) - The equipment that provides the functions required to establish, maintain, and terminate a connection, the signal conversion, and coding required for communication between data terminal equipment and data circuit. (A MODEM is normally considered as the DCE.)

DATA SET - In communications equipment, the DCE; in information, a collection of data records with logical relation of one to another.

DATA TRANSMISSION - The sending of data from one place for reception elsewhere.

DECIBEL - The standard unit for expressing the ratio between powers.

DEMODULATION - The process of retrieving an original signal from a modulated carrier wave. Used in data sets to make communications signals compatible with computer signals.

DISTORTION - An undesirable change in a signal waveform as compared with the original that degrades the fidelity.

ENCRYPTION DEVICE - A device which converts transmitted messages into code.

FEEDBACK - A portion of output signal returned to the input of a circuit for error detection and correction.

FREQUENCY MODULATION - A method of transmission whereby the frequency of the carrier wave is changed to correspond to changes in the information signal wave.

FREQUENCY SHIFT KEYING - A method of frequency modulation in which frequency is made to vary at significant instants by smooth as well as abrupt transitions. Typically a data "1" is represented by one frequency and a data "0" as another frequency.

FULL DUPLEX - The ability to transmit and receive simultaneously, normally used in reference to four-wire systems.

GATE - A circuit having two or more inputs and a single output, the output signal depending on the combination of signals at the inputs.

HANDSET - A standard PTT microphone.

HERTZ - A unit of frequency equal to one cycle per second.

HOPSET - The controlled changes in radio operation frequency in which the changes do not conform to a systematic pattern of frequency or duration of change.

INTERFACE - A device or equipment making possible interoperation between two circuits or systems.

INTERLEAVE - Time division multiplexing. In time division multiplexing, a single bus is used to connect multiple circuits performing multiple operations. The time during which signals on the bus are active is limited to the time during which the intended receiving circuit is enabled.

INTERLOCK - A circuit in which the action of one portion of the circuit is dependent upon conditions of an associated circuit.

KILOHERTZ - One thousand Hertz.

LINK - Any specified relationship between two nodes in a network. A communications path between two nodes.

MARK - The presence of a signal. In telegraphy, MARK represents the closed condition or current flowing. Equivalent to a binary one condition.

HARMONIC - A frequency that is a multiple of the fundamental sine wave frequency of a signal.

HARMONIC DISTORTION - A deviation from the original signal caused by the presence of harmonic frequencies not in the original signal.

MEGAHERTZ - One million Hertz.

MODE - A particular functional arrangement or condition, i.e., Receive Mode which sets up circuits into particular conditions to receive as opposed to Transmit Mode which arranges functional circuits into different conditions.

MODEM - Modulator/demodulator. A device that modulates and demodulates signals transmitted over communications circuits.

MODULATION - Impressing information on a carrier signal by varying the carrier's amplitude, phase, frequency, or other characteristic.

NMI - Non-maskable interrupt, a microprocessor interrupt which causes the microprocessor to reset to a known state.

OSCILLATION - A sustained condition of continuous operation where the circuit outputs a constant signal at a frequency determined by circuit constants and as a result of positive or regenerative feedback.

OSCILLATOR - A device or circuit in which oscillation occurs.

PACKET - A group of bits including data and control elements which is transmitted as a composite whole.

PARALLEL TRANSMISSION - A method of transmission in which each group of information bits is sent simultaneously over a set of parallel lines rather than serially over a single line.

PARITY CHECK - Addition of non-information bits to data, making the number of ones in each grouping of bits either always odd, for odd parity, or always even, for even parity. This permits single error detection of each group.

POLLING - The process of inviting another station, node, or circuit to transmit data.

PORT - A place of access to a system or circuit

PROTOCOL - A formal set of conventions governing the format and relative timing of message exchange between two communication processes.

QWERTY KEYBOARD - Standard U.S. typewriter keyboard. Named for the first row of alphabetical keys which begins with Q, W, E, R, T, and Y.

RS-232C - The binary serial interchange that is the EIA recommended standard (RS-) for data processing equipment to be interfaced to a carrier. The data processing equipment is referred to as Data Terminal Equipment (DTE) and the carrier (or MODEMS) are referred to as Data Communications Equipment (DCE). The C denotes that it is the third update of the standard. The standard defines the voltage minimum (3 volt), the voltage maximum (25 volt), and terminal impedance (3000 - 7000 ohm). Negative polarity indicates the binary state 1, marking or OFF control state. The positive polarity indicates the binary state 0, spacing or an ON control state. Normally the distance between DCE and DTE is defined as 50 feet, maximum.

RS-442 - A revision of the interface standard that permits TTL voltage levels and increases the distance permitted between the DTE/DCE.

SELECTIVITY - The characteristic which describes the ability of a tuned circuit or a receiver to select the frequencies desired and reject the ones not desired.

SERIAL TRANSMISSION - A method of transmission in which each bit of information is sent sequentially on a single channel rather than simultaneously as a parallel transmission.

SIDEBANDS - The frequency bands which are formed on both sides of a modulated carrier by the sum and difference of the information frequency and the carrier frequency.

SPURIOUS EMISSIONS - Emissions from a radio transmitter at frequencies outside of its assigned or intended emission frequency. These include harmonic emissions, parasitic emissions, and intermodulation, but do not include emissions in the immediate vicinity of baseband, which are a product of the modulation process.

SPURIOUS SUSCEPTIBILITY - The undesired response of equipment to spurious emissions.

SYNCHRONOUS TRANSMISSION - Transmission in which the data characters and bits are transmitted at a fixed rate with the transmitter and receiver synchronized. This eliminates the need for start-stop elements, providing a greater efficiency.

SYNTHESIZER - A device that can generate a number of controlled frequencies for multichannel communications equipment.

TALK - In digital communications, the action of receiving and transmitting data between data terminal equipments.

TIME-DIVISION MULTIPLEXING - A system of multiplexing in which channels are established by connecting terminals one at a time at regular intervals by means of an automatic distribution.

TRANSORBER - A device that clamps incoming voltage spikes to a lower value for protection of electrical and electronic circuits. A device most commonly used for this is two zeners back-to-back.

VITERBI CODE - A set of rules according to which data signals on the RN Modem data bus are formatted and synchronized to the time and variable controls selected for the KG-84A.

WIDEBAND - Communications channel having a bandwidth greater than a voice-grade channel characterized by data transmission speed of 10,000 to 500,000 bits per second.

WORD - An ordered set of characters that is the normal unit in which information may be stored, transmitted, or operated upon within a computer.

SUBJECT INDEX (Cont.)

<u>Subject</u>	<u>Paragraph</u>
F	
FLOW CHARTS AND HOW TO USE THEM	3-7
FUNCTIONAL DESCRIPTION OF MAJOR COMPONENTS	1-14
FUNCTIONAL DESCRIPTION OF RT	1-13
FUNCTIONAL TEST, POWER SUPPLY	3-10
G	
GENERAL (Unit Maintenance Procedures)	2-11
GENERAL (Unit Troubleshooting)	2-9
GENERAL (Intermediate General Support Maintenance Procedures)	3-11
GENERAL (Intermediate General Support Troubleshooting)	3-4
H, I	
IDENTIFICATION PLATES	1-10
IF RECEIVER ASSEMBLY A9, REPLACEMENT OF	3-29
INCANDESCENT LAMP OR INDICATOR LENS LAMPHOLDER, REPLACEMENT OF	2-14
INDEX OF PUBLICATIONS AND BLANK FORMS	1-3
INTRODUCTION	2-7
J, K, L	
LANYARD ASSEMBLY, REPLACEMENT OF	2-17
LOCATION AND DESCRIPTION OF MAJOR COMPONENTS	1-9
M	
MAINTENANCE FORMS, RECORDS, AND REPORTS	1-2
MAJOR COMPONENTS, FUNCTIONAL DESCRIPTION OF	1-14
MARKING	2-19
N, O	
OFFICIAL NOMENCLATURE, NAMES, AND DESIGNATIONS	1-7

SUBJECT INDEX (Cont.)

<u>Subject</u>	<u>Paragraph</u>
P	
POWER SUPPLY PS1, DISASSEMBLY OF	3-32
POWER SUPPLY PS1, REPLACEMENT OF	3-31
PRELIMINARY SERVICING AND ADJUSTMENT OF EQUIPMENT	2-6
PRELIMINARY TROUBLESHOOTING PROCEDURES (BIT TEST)	3-5
PREPARATION FOR STORAGE OR SHIPMENT	1-6
PREPARATION FOR STORAGE OR SHIPMENT	2-18
PRINTED CABLE ASSEMBLY, FLEXIBLE INTERCONNECT A1W3, REPLACEMENT OF	3-18
PS AC TO DC INVERTER CCA PS1A2, REPLACEMENT OF	3-36
PS TROUBLESHOOTING	3-10
Functional Test	3-10
Current Limiting Circuit, +8,3 V	3-10
Current Limiting Circuit, +12 V	3-10
Current Limiting Circuit, +28 V	3-10
Current Limiting Circuit, -12 V	3-10
Output Circuit, +5 V	3-10
Output Circuit, +8.3 V	3-10
Output Circuit, +12 V	3-10
Output Circuit, +28 V	3-10
Output Circuit, -12 V	3-10
Power Transformer Current Limiting Circuit	3-10
Selecting +8.3 V Current Limiting Resistor A3R23	3-10
Selecting +12 V Current Limiting Resistor A3R14	3-10
Selecting +28 V Current Limiting Resistor A3R20	3-10
Selecting -12 V Current Limiting Resistor A3R16	3-10
Selecting +5 V Regulator Resistor A2R56	3-10
Power Transformer Current Limiting Resistor A3R12	3-10
Troubleshooting of the Complete Power Supply	3-10
PS CHASSIS MOUNTED REGULATOR PS1U1U1, REPLACEMENT OF	3-35
PS REGULATOR OUTPUT CCA PS1A3, REPLACEMENT OF	3-33
Q, R	
RADIO FREQUENCY MULTICIRCUIT FILTER FL3, REPLACEMENT OF	3-23
REFERENCE OSCILLATOR ASSEMBLY A4, REPLACEMENT OF	3-24
REPAIR OF PS AC TO DC INVERTER CCA PS1A2	3-37
REPAIR OF PS REGULATOR OUTPUT CCA PS1A3	3-34
REPAIR PARTS	2-3
REPAIR PARTS	3-3

SUBJECT INDEX (Cont.)

Subject Paragraph

R (Cont.)

REPLACEMENT OF

Audio Receiver Assembly A10	3-30
Audio Sideband Exciter Assembly A5	3-25
Band Pass Filter, FL2	3-20
Bow Handle	2-16
Cable Assemblies A1W1 and/or A1W2	3-15
Cable Assembly A1W4	3-16
Chassis Cable Assemblies W1,W2,W3,W6,W7, and W8	3-13
Chassis Cable Assemblies W4,W5,W9, and W10	3-14
Chassis Module Interconnect CCA A1A1	3-17
Controller, Receiver-Transmitter C-11670/G	2-13
Controller, Receiver-Transmitter C-11670/G	3-22
EMI Filter, FL1	3-19
IF Receiver Assembly A9	3-29
Incandescent Lamp or Indicator Lens Lampholder	2-14
Lanyard Assembly	2-17
PS Chassis Mounted Regulator PS1A1U1	3-35
PS AC to DC Inverter CCA PS1A2	3-36
PS Regulator Output CCA PS1A3	3-33
Power Supply PS1	3-31
Printed Cable Assembly, Flexible Interconnect A1W3	3-18
Radio Frequency Multicircuit Filter FL3	3-21
Reference Oscillator Assembly A4	3-24
RF Amplifier Exciter Assembly A6	3-26
RF Receiver Assembly A7	3-28
RF Switch Assembly A7	3-27
RT Covers	3-12
Synthesizer A3	3-23
Thumbscrew	2-15

REPORTING EQUIPMENT IMPROVEMENT RECOMMENDATIONS

(EIR)	1-4
RF AMPLIFIER EXCITER ASSEMBLY A6, REPLACEMENT OF	3-26
RF RECEIVER ASSEMBLY A8, REPLACEMENT OF	3-28
RF SWITCH ASSEMBLY A7, REPLACEMENT OF	3-27
RT, COVERS, REPLACEMENT OF	3-12
RT WILL NOT TURN ON	3-8
RT, FUNCTIONAL DESCRIPTION OF	1-13

S

SAFETY, CARE, AND HANDLING	1-12
SCOPE	1-1
SPECIAL TOOLS, TMDE, AND SUPPORT EQUIPMENT	2-2
SPECIAL TOOLS, TMDE, AND SUPPORT EQUIPMENT	3-2
SYNTHESIZER A3, REPLACEMENT OF	3-23

SUBJECT INDEX (Cont.)

<u>Subject</u>	<u>Paragraph</u>
T	
THUMBSCREW, REPLACEMENT OF	2-15
TOOLS AND EQUIPMENT, COMMON	2-1
TOOLS AND EQUIPMENT, COMMON	3-1
TROUBLESHOOTING PROCEDURES, UNIT	2-10
TROUBLESHOOTING PROCEDURES, INTERMEDIATE	3-6

U	
UNIT PMCS TABLE	2-8
UNPACKING	2-4

V-W-X-Y-Z

RECOMMENDED CHANGES TO EQUIPMENT TECHNICAL PUBLICATIONS

SOMETHING WRONG WITH THIS PUBLICATION?



THEN... JOT DOWN THE DOPE ABOUT IT ON THIS FORM. CAREFULLY TEAR IT OUT. FOLD IT AND DROP IT IN THE MAIL!

FROM: (PRINT YOUR UNIT'S COMPLETE ADDRESS)
 Commander
 Stateside Army Depot
 ATTN: AMSTA-US
 Stateside, N.J. 07703-5007

DATE SENT
 10 July 1975

PUBLICATION NUMBER
 TM 11-5840-340-12

PUBLICATION DATE
 23 Jan 74

PUBLICATION TITLE
 Radar Set AN/PRC-76

BE EXACT... PIN-POINT WHERE IT IS

PAGE NO	PARA-GRAPH	FIGURE NO	TABLE NO
2-25	2-28		
3-10	3-3		3-1
5-6	5-8		

IN THIS SPACE TELL WHAT IS WRONG AND WHAT SHOULD BE DONE ABOUT IT:

Recommend that the installation antenna alignment procedure be changed throughout to specify a 2° IFF antenna lag rather than 1°.

REASON: Experience has shown that with only a 1° lag, the antenna servo system is too sensitive to wind gusting in excess of 25 knots, and has a tendency to rapidly accelerate and decelerate as it hunts, causing strain to the drive train. Hunting is minimized by adjusting the lag to 2° without degradation of operation.

Item 5, Function column. Change "2 db" to "3db."

REASON: The adjustment procedure for the TRANS POWER FAULT indicator calls for a 3 db (500 watts) adjustment to light the TRANS POWER FAULT indicator.

Add new step f.1 to read, "Replace cover plate removed in step e.1, above."

REASON: To replace the cover plate.

Zone C 3. On J1-2, change "+24 VDC to "+5 VDC."

REASON: This is the output line of the 5 VDC power supply. +24 VDC is the input voltage.

PRINTED NAME, GRADE OR TITLE, AND TELEPHONE NUMBER
 SSG I. M. DeSpirito 999-1776

SIGN HERE

TEAR ALONG PERFORATED LINE

FILL IN YOUR
UNIT'S ADDRESS

FOLD BACK

DEPARTMENT OF THE ARMY

OFFICIAL BUSINESS
PENALTY FOR PRIVATE USE \$300

POSTAGE AND FEES PAID
DEPARTMENT OF THE ARMY
DOD 314



TEAR ALONG PERFORATED LINE

SAMPLE

Commander
US Army Communications-Electronics Command
and Fort Monmouth
ATTN: AMSEL-LC-ME-PS
Fort Monmouth, New Jersey 07703-5000

RECOMMENDED CHANGES TO EQUIPMENT TECHNICAL PUBLICATIONS

SOMETHING WRONG WITH THIS PUBLICATION?



THEN...JOT DOWN THE DOPE ABOUT IT ON THIS FORM. CAREFULLY TEAR IT OUT, FOLD IT AND DROP IT IN THE MAIL.

FROM: (PRINT YOUR UNIT'S COMPLETE ADDRESS)

DATE SENT

PUBLICATION NUMBER

TM 11-5895-1303-24

PUBLICATION DATE

15 May 1989

PUBLICATION TITLE

Receiver-Transmitter
RT-1512/G

BE EXACT PIN-POINT WHERE IT IS

PAGE NO	PARA-GRAPH	FIGURE NO	TABLE NO

IN THIS SPACE TELL WHAT IS WRONG AND WHAT SHOULD BE DONE ABOUT IT:

PRINTED NAME GRADE OR TITLE AND TELEPHONE NUMBER

SIGN HERE

DA FORM 2028-2
1 JUL 79

PREVIOUS EDITIONS ARE OBSOLETE

P.S...IF YOUR OUTFIT WANTS TO KNOW ABOUT YOUR RECOMMENDATION MAKE A CARBON COPY OF THIS AND GIVE IT TO YOUR HEADQUARTERS.

TEAR ALONG PERFORATED LINE.

FILL IN YOUR
UNIT'S ADDRESS

FOLD BACK

DEPARTMENT OF THE ARMY

OFFICIAL BUSINESS



TEAR ALONG PERFORATED LINE

Commander
US Army Communications-Electronics Command
and Fort Monmouth
ATTN: AMSEL-LC-ME-PS
Fort Monmouth, New Jersey 07703-5000

RECOMMENDED CHANGES TO EQUIPMENT TECHNICAL PUBLICATIONS



THEN...JOT DOWN THE DOPE ABOUT IT ON THIS FORM. CAREFULLY TEAR IT OUT, FOLD IT AND DROP IT IN THE MAIL.

SOMETHING WRONG WITH THIS PUBLICATION?

FROM: (PRINT YOUR UNIT'S COMPLETE ADDRESS)

DATE SENT

PUBLICATION NUMBER

TM 11-5895-1303-24

PUBLICATION DATE

15 May 1989

PUBLICATION TITLE

Receiver-Transmitter
RT-1512/G

BE EXACT PIN-POINT WHERE IT IS

PAGE NO	PARA. GRAPH	FIGURE NO	TABLE NO
---------	-------------	-----------	----------

IN THIS SPACE TELL WHAT IS WRONG AND WHAT SHOULD BE DONE ABOUT IT:

TEAR ALONG PERFORATED LINE

PRINTED NAME GRADE OR TITLE AND TELEPHONE NUMBER

SIGN HERE

DA FORM 2028-2
1 JUL 78

PREVIOUS EDITIONS ARE OBSOLETE

P.S.-IF YOUR OUTFIT WANTS TO KNOW ABOUT YOUR RECOMMENDATION MAKE A CARBON COPY OF THIS AND GIVE IT TO YOUR HEADQUARTERS.

FILL IN YOUR
UNIT'S ADDRESS

FOLD BACK

DEPARTMENT OF THE ARMY

OFFICIAL BUSINESS



TEAR ALONG PERFORATED LINE

Commander
US Army Communications-Electronics Command
and Fort Monmouth
ATTN: AMSEL-LC-ME-PS
Fort Monmouth, New Jersey 07703-5000

RECOMMENDED CHANGES TO EQUIPMENT TECHNICAL PUBLICATIONS

SOMETHING WRONG WITH THIS PUBLICATION?



THEN...JOT DOWN THE DOPE ABOUT IT ON THIS FORM. CAREFULLY TEAR IT OUT, FOLD IT AND DROP IT IN THE MAIL.

FROM: (PRINT YOUR UNIT'S COMPLETE ADDRESS)

DATE SENT

PUBLICATION NUMBER

TM 11-5895-1303-24

PUBLICATION DATE

15 May 1989

PUBLICATION TITLE

Receiver-Transmitter
RT-1512/G

BE EXACT PIN-POINT WHERE IT IS

PAGE NO	PARA-GRAPH	FIGURE NO	TABLE NO
---------	------------	-----------	----------

IN THIS SPACE TELL WHAT IS WRONG AND WHAT SHOULD BE DONE ABOUT IT:

TEAR ALONG REGISTERED LINE

PRINTED NAME GRADE OR TITLE AND TELEPHONE NUMBER

SIGN HERE

DA FORM 2028-2
1 JUL 79

PREVIOUS EDITIONS
ARE OBSOLETE

P.S.—IF YOUR OUTFIT WANTS TO KNOW ABOUT YOUR
RECOMMENDATION MAKE A CARBON COPY OF THIS
AND GIVE IT TO YOUR HEADQUARTERS.

FILL IN YOUR
UNIT'S ADDRESS

FOLD BACK

DEPARTMENT OF THE ARMY

OFFICIAL BUSINESS



TEAR ALONG PERFORATED LINE

Commander
US Army Communications-Electronics Command
and Fort Monmouth
ATTN: AMSEL-LC-ME-PS
Fort Monmouth, New Jersey 07703-5000

NOTES:

1.0 GENERAL:

1.1 CHARACTERS UNDERLINED DENOTE LOWER CASE.

2.0 SPECIFIC:

2.1 UNLESS OTHERWISE SPECIFIED:
VOLTAGES ARE DC.

2.2

2.3

2.4 USED ON ASSEMBLY A3023756 ONLY.

2.5 REFERENCE:
ASSEMBLY PART NUMBER A3023756 AND A3023757.

2.6 PART NUMBER MS25237-387.

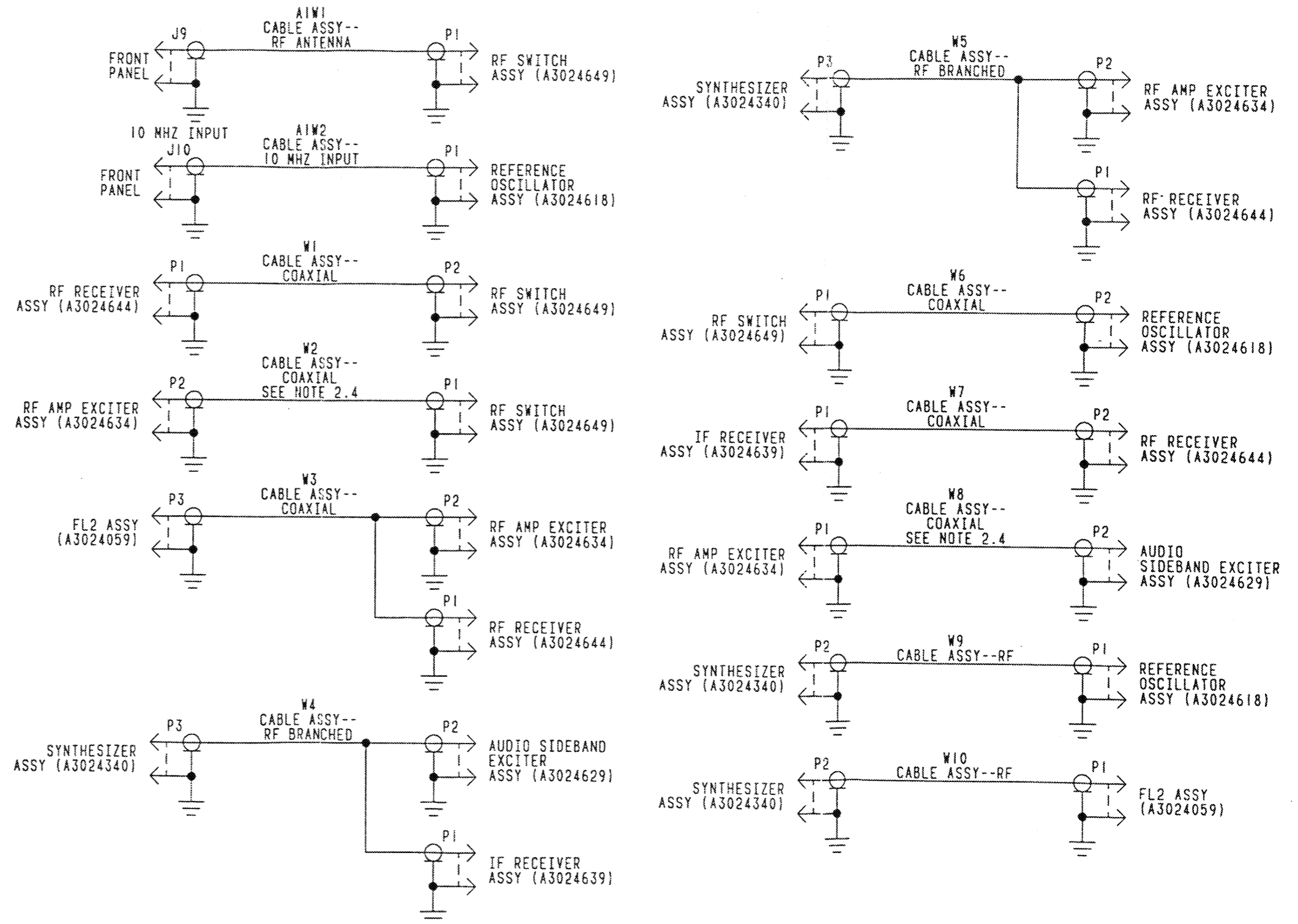

CEOJW-001

Figure FO-1. Chassis
Assembly Wiring Diagram
(Sheet 1 of 4)

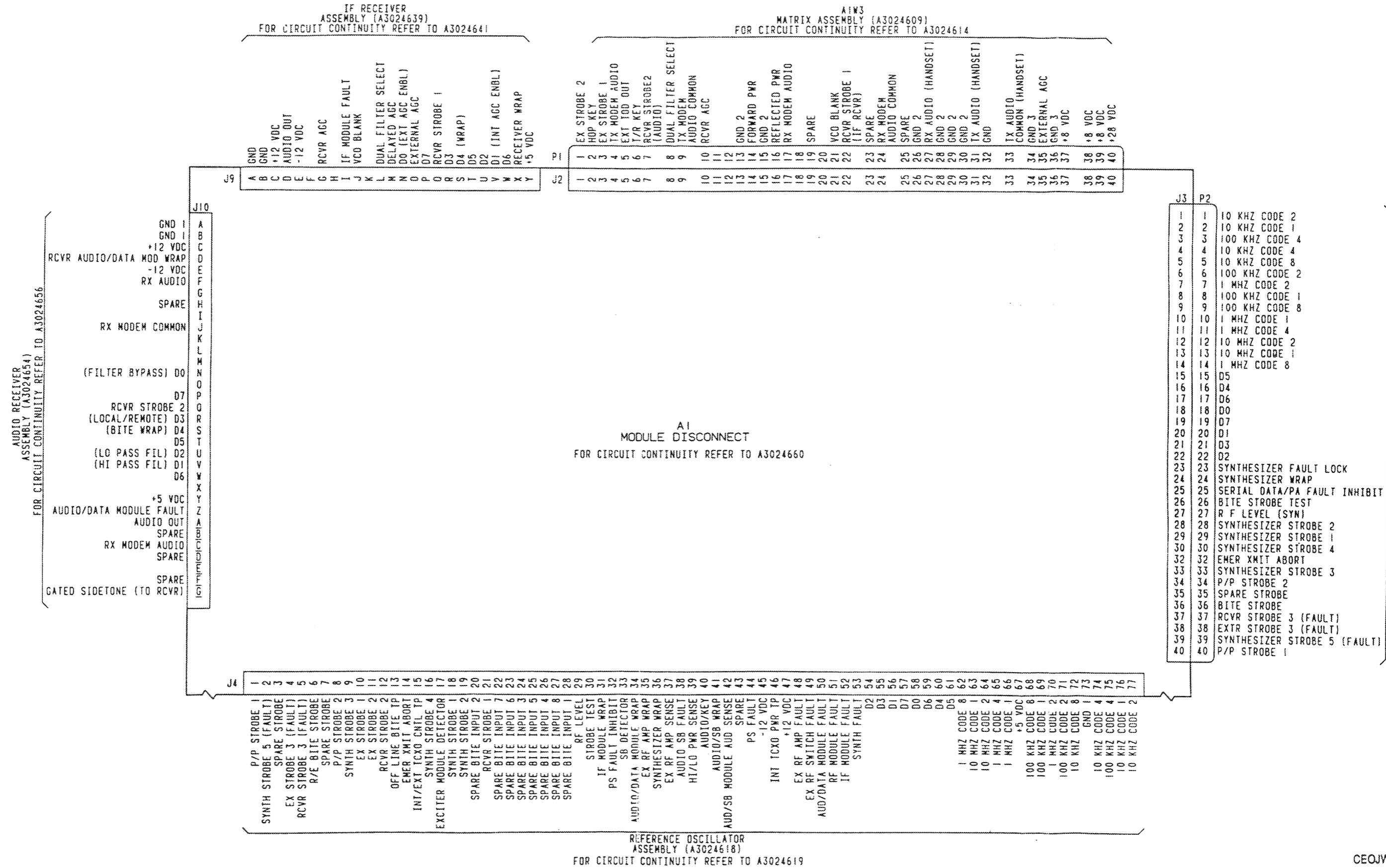
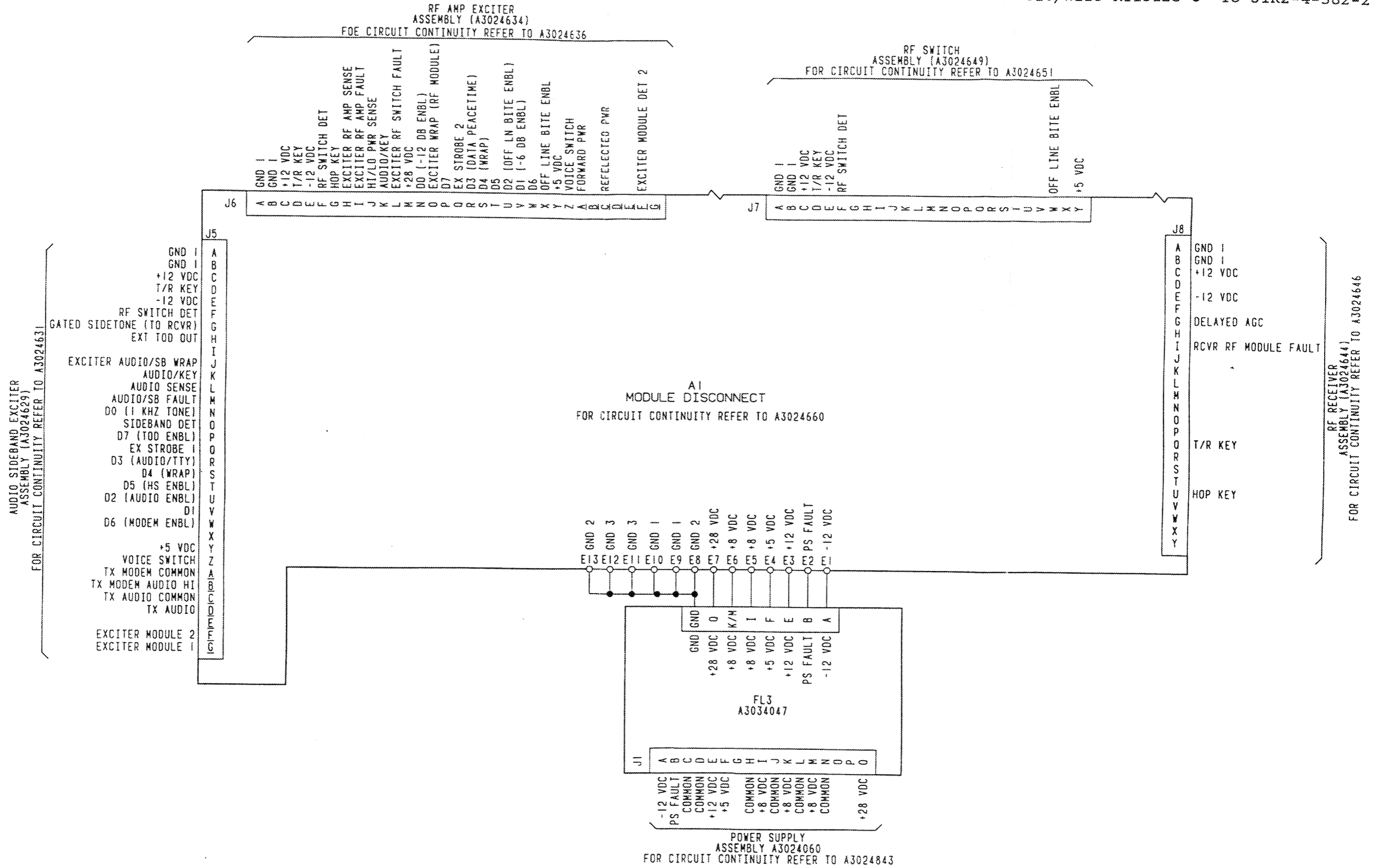

Figure FO-1. Chassis Assembly Wiring Diagram (Sheet 2 of 4)



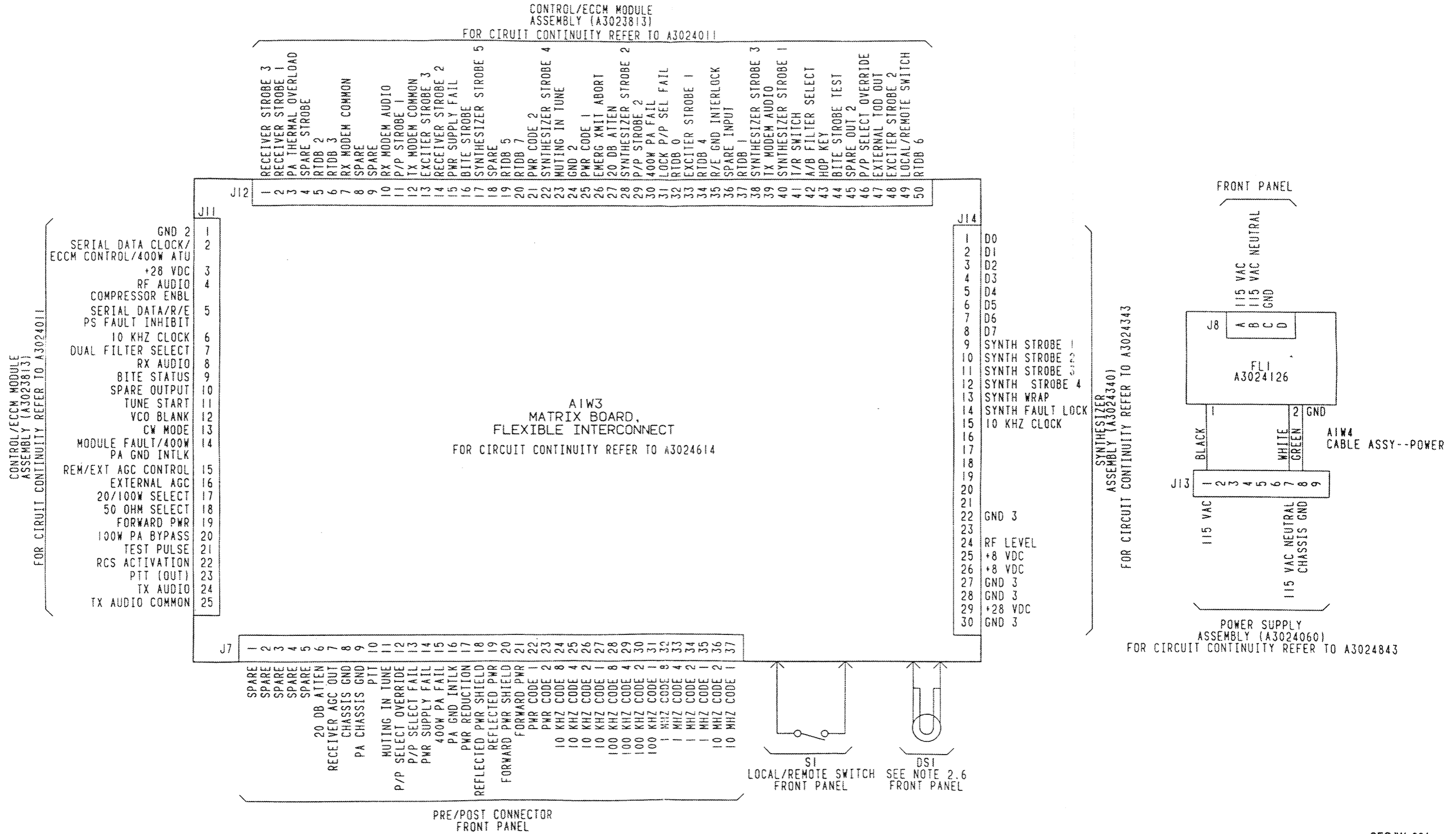

Figure FO-1. Chassis
Assembly Wiring Diagram
(Sheet 4 of 4)

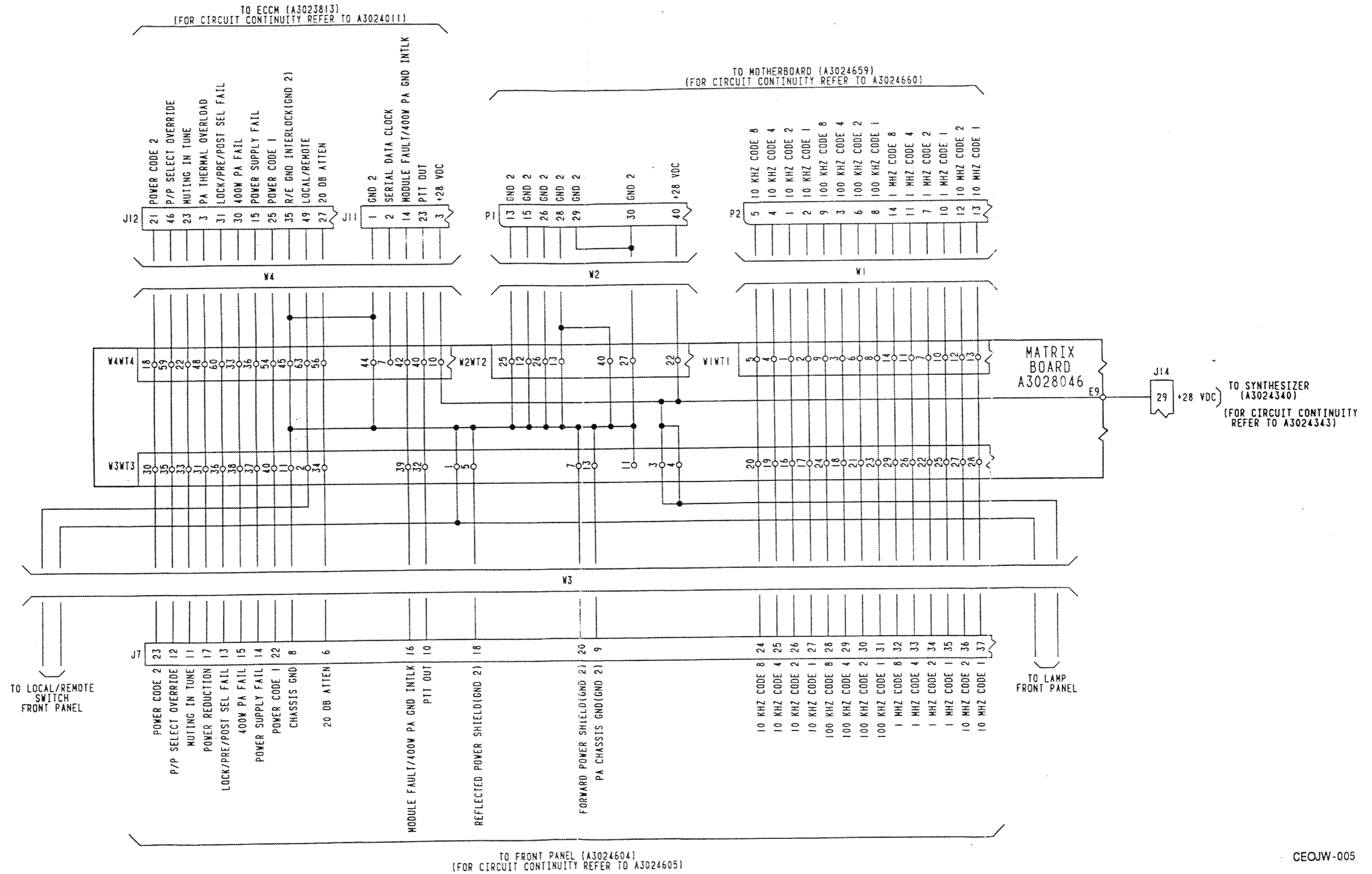

Figure FO-2. Flexible Interconnect Matrix Board Wiring Diagram (Sheet 1 of 3)

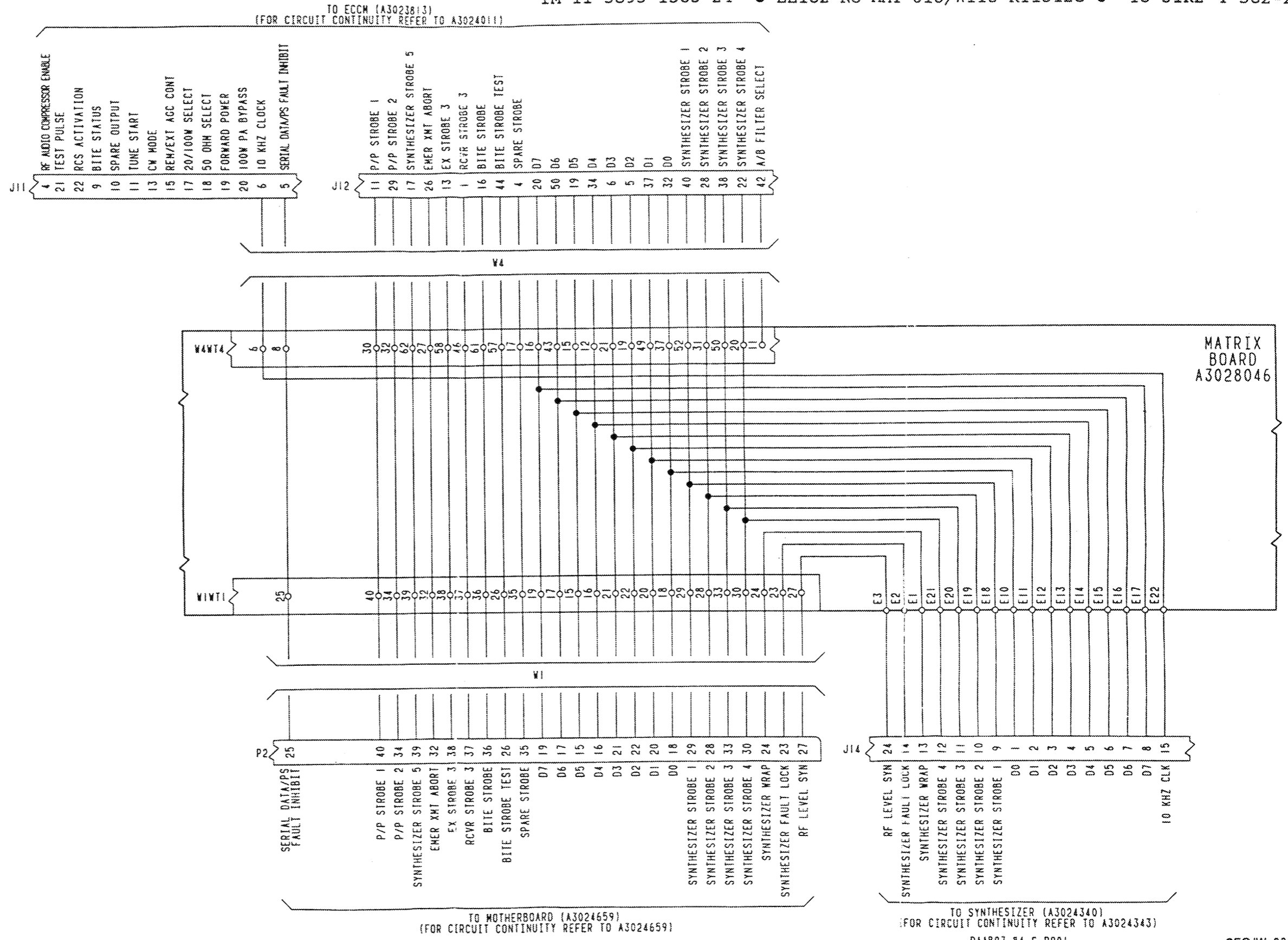

Figure FO-2. Flexible Interconnect Matrix Board Wiring Diagram (Sheet 2 of 3)

DAA807-84-C-0001

CEOJW-006

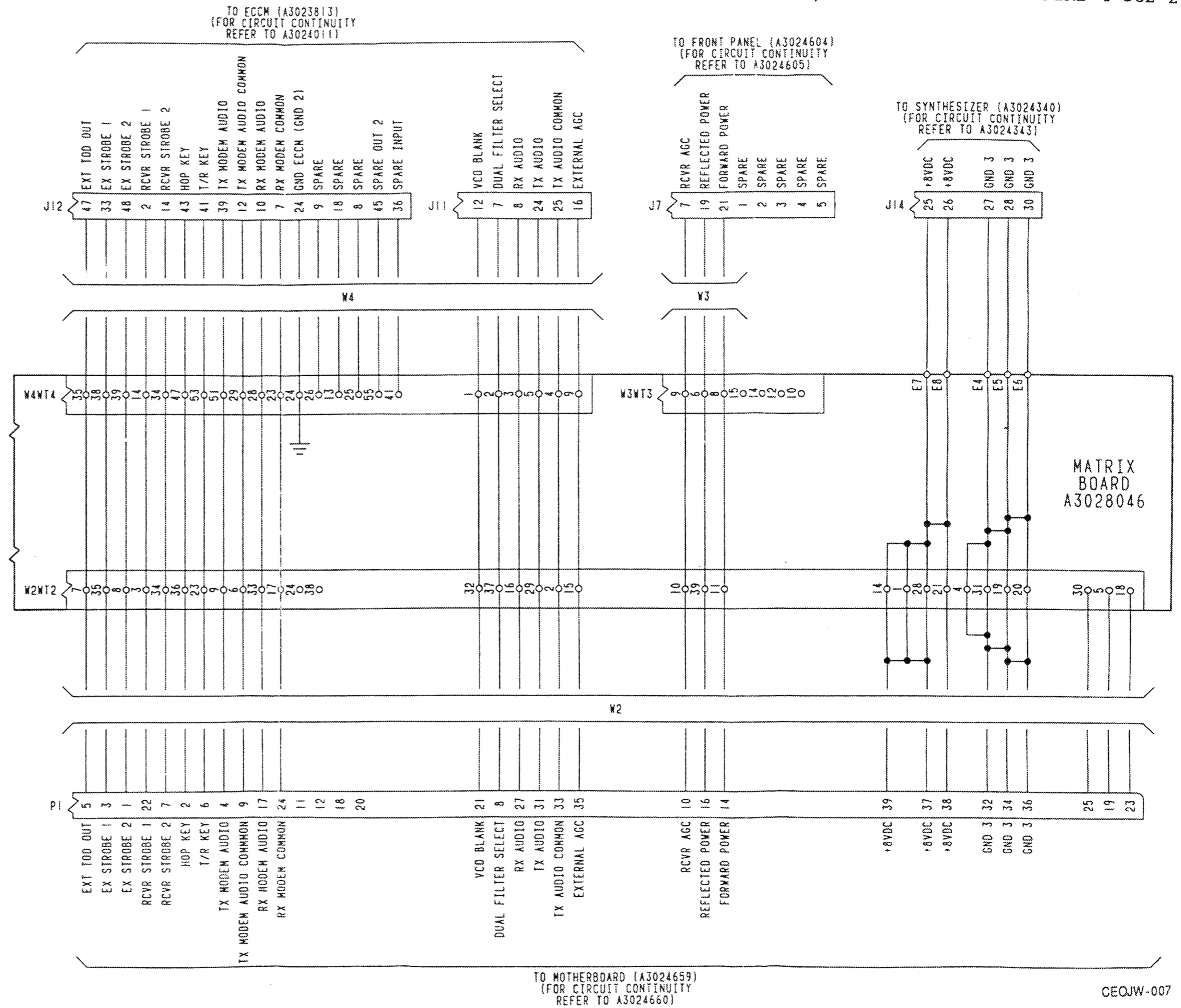
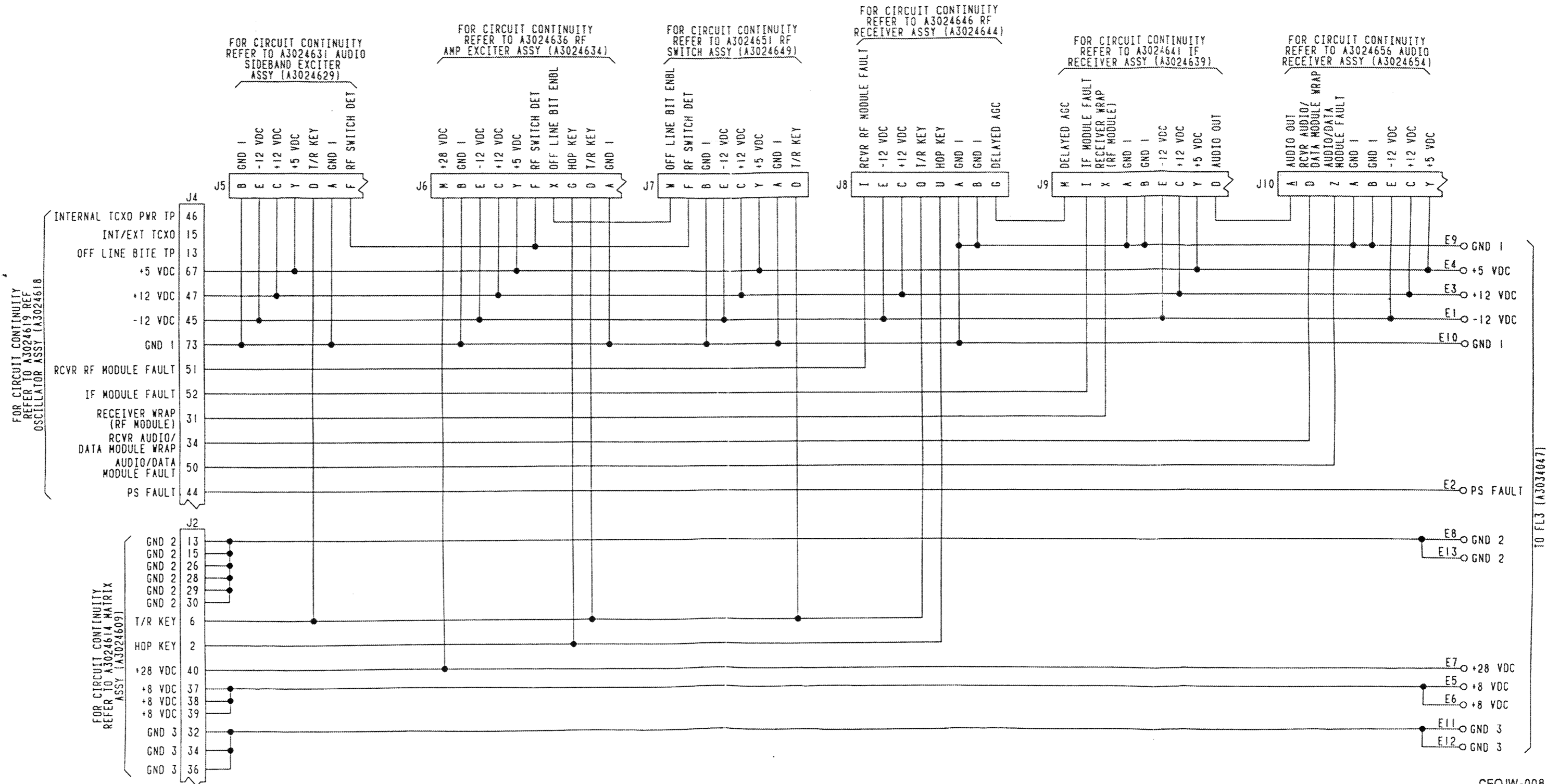

Figure FO-2. Flexible Interconnect Matrix Board Wiring Diagram (Sheet 3 of 3)



CEOJW-008

Figure FO-3. Module Interconnect Wiring Diagram (Sheet 1 of 3)

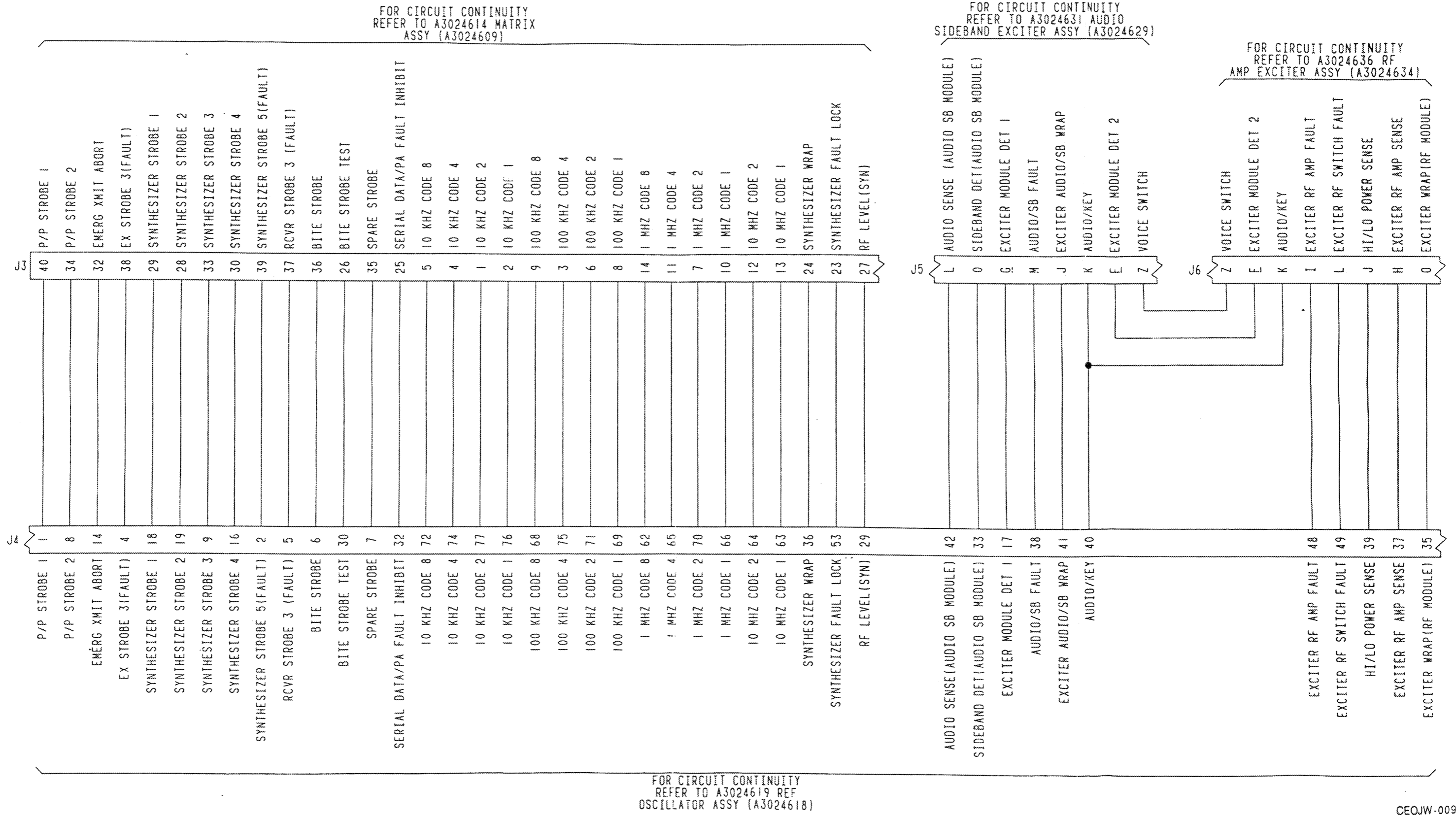

Figure FO-3. Module Interconnect Wiring Diagram (Sheet 2 of 3)

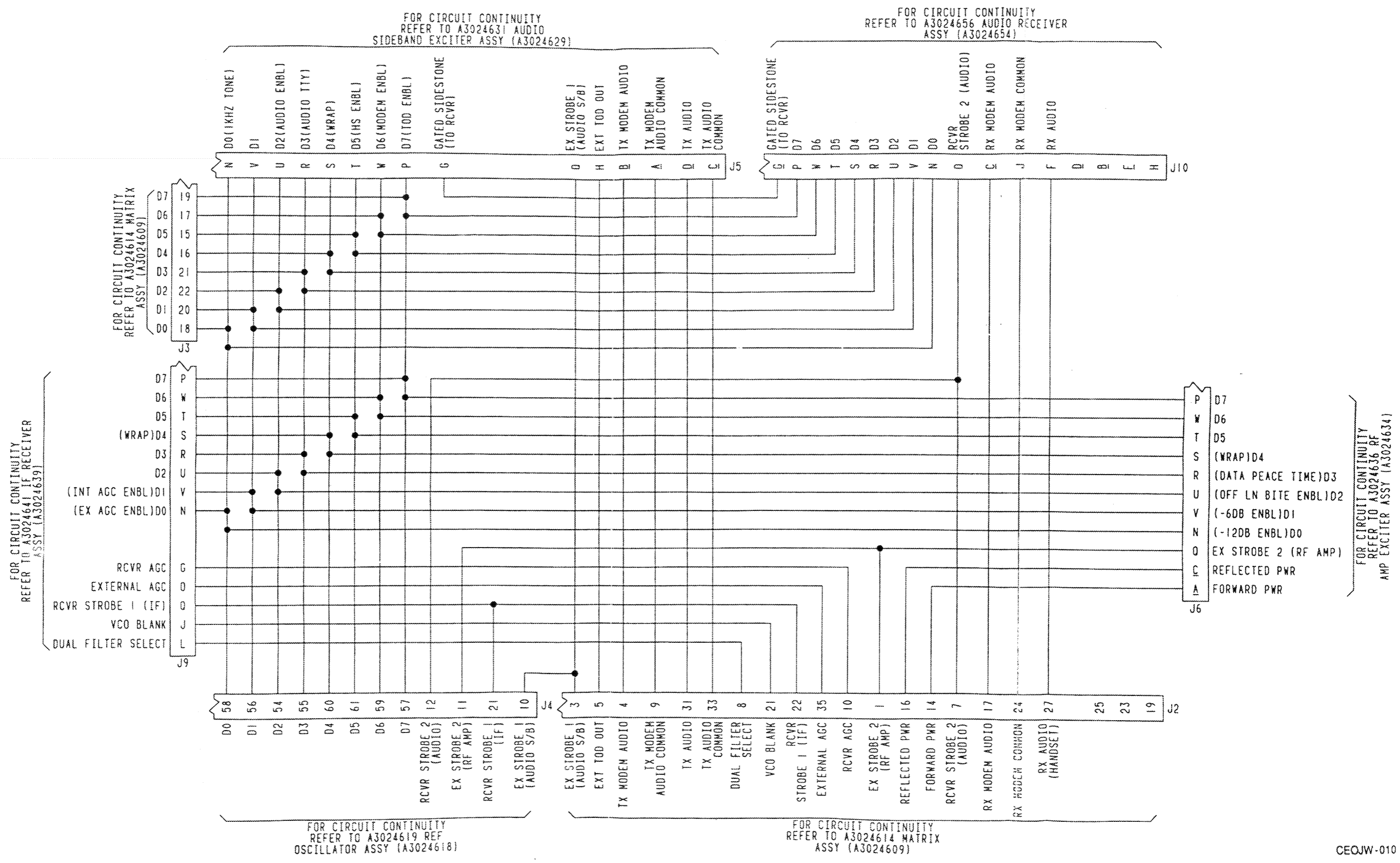
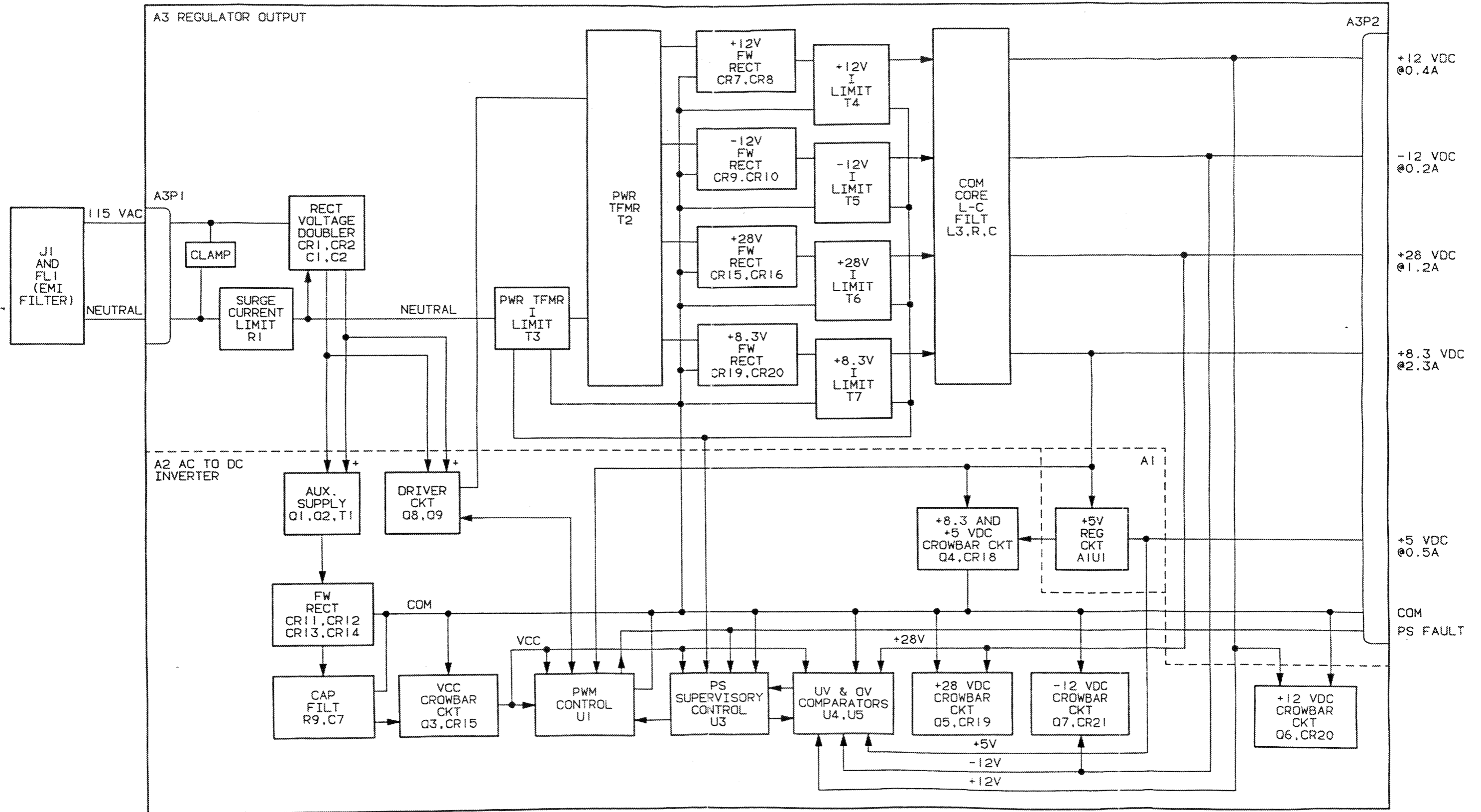
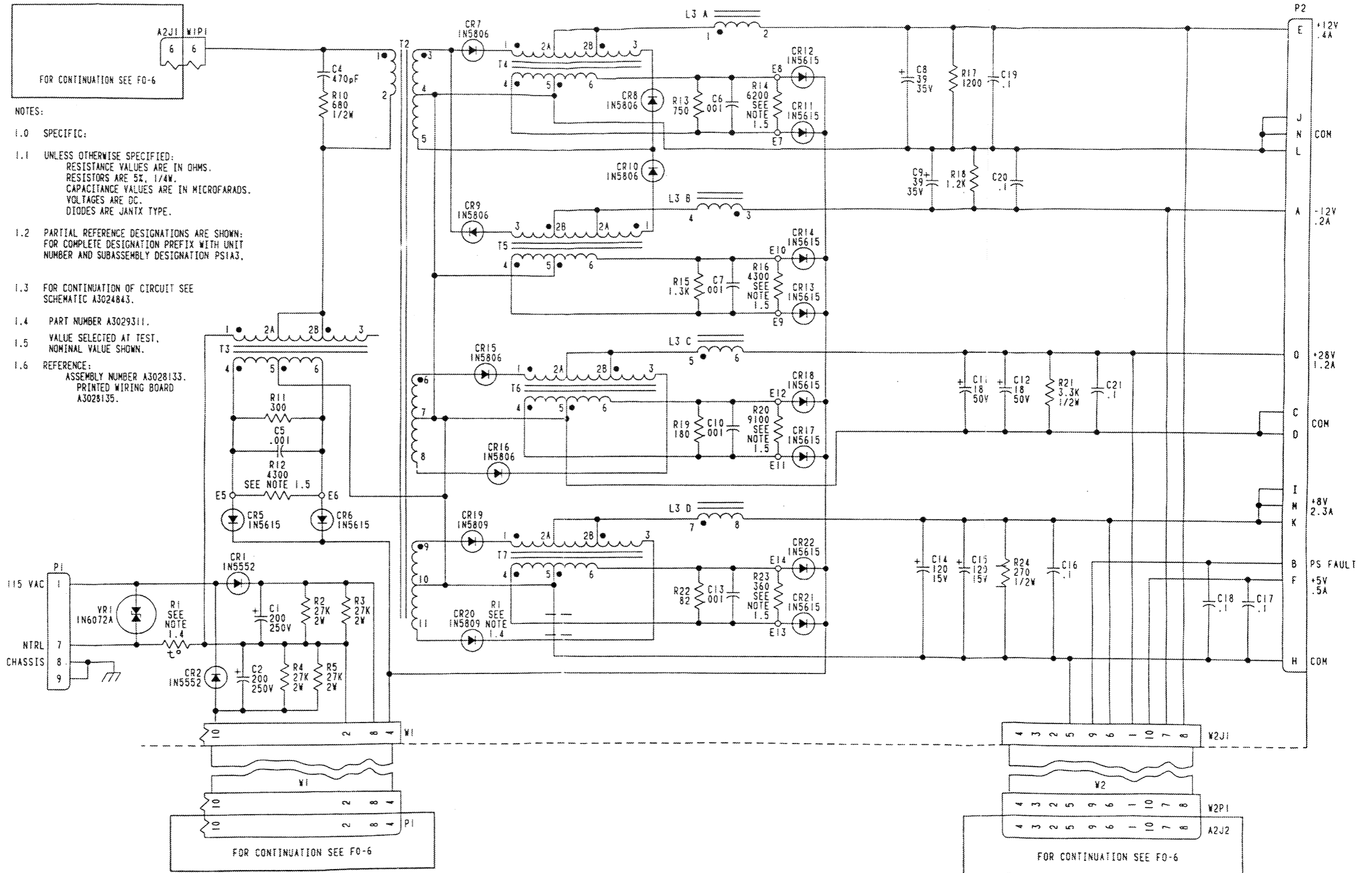

Figure FO-3. Module Interconnect Wiring Diagram (Sheet 3 of 3)



CEOJW-011

Figure FO-4. Power Supply Block Diagram



- NOTES:
- 1.0 SPECIFIC:
 - 1.1 UNLESS OTHERWISE SPECIFIED:
RESISTANCE VALUES ARE IN OHMS.
RESISTORS ARE 5%, 1/4W.
CAPACITANCE VALUES ARE IN MICROFARADS.
VOLTAGES ARE DC.
DIODES ARE JANIX TYPE.
 - 1.2 PARTIAL REFERENCE DESIGNATIONS ARE SHOWN:
FOR COMPLETE DESIGNATION PREFIX WITH UNIT
NUMBER AND SUBASSEMBLY DESIGNATION PS1A3.
 - 1.3 FOR CONTINUATION OF CIRCUIT SEE
SCHEMATIC A3024843.
 - 1.4 PART NUMBER A3029311.
 - 1.5 VALUE SELECTED AT TEST,
NOMINAL VALUE SHOWN.
 - 1.6 REFERENCE:
ASSEMBLY NUMBER A3028133.
PRINTED WIRING BOARD
A3028135.

CEOJW-012

Figure FO-5. Schematic of PS Regulator Output PS1A3

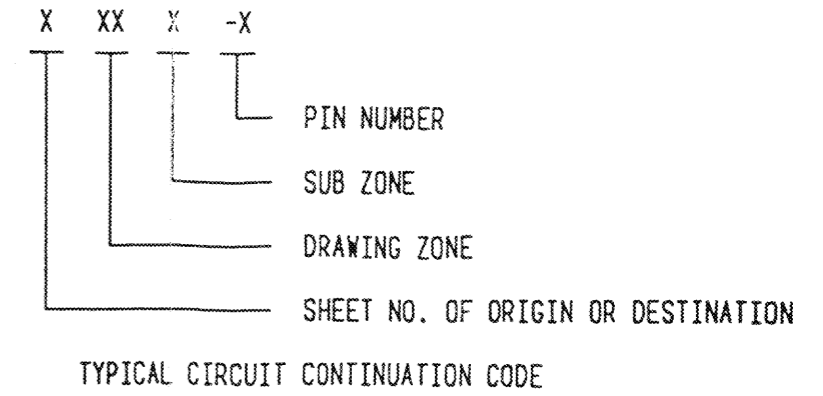

NOTES:

1.0 SPECIFIC:

- 1.1 UNLESS OTHERWISE SPECIFIED:
RESISTANCE VALUES ARE IN OHMS.
RESISTORS ARE 5%, 1/4W.
1% RESISTORS ARE 1/8W.
CAPACITANCE VALUES ARE IN MICROFARADS.
VOLTAGES ARE DC.
DIODES AND/OR TRANSISTORS ARE JANTX TYPE.
- 1.2 PARTIAL REFERENCE DESIGNATIONS ARE SHOWN:
FOR COMPLETE DESIGNATION PREFIX WITH UNIT
NUMBER AND SUBASSEMBLY DESIGNATION 1A1PSI, 1A2PSI, 1A3PSI,
1A4PSI, 1A5PSI, 6A1PSI, 6A2PSI, 6A3PSI, 6A4PSI AND 6A5PSI.
- 1.3 FOR CONTINUATION OF CIRCUIT SEE
SCHEMATIC A3024605.
- 1.4 PART NUMBER A3028262.
- 1.5 PART NUMBER A3028267.
- 1.6  THIS DEVICE REQUIRES SPECIAL HANDLING
AND PROCESSING TO PREVENT DAMAGE FROM
ELECTROSTATIC DISCHARGE TRANSIENTS.
- 1.7 VALUE SELECTED AT TEST, NOMINAL VALUE SHOWN.
- 1.8 REFERENCE:
ASSEMBLY NUMBER A3024060.
A2 ASSEMBLY NUMBER A3024841.
PRINTED WIRING BOARD A3024842.

CEOJW-013

Figure FO-6. Schematic
of PS AC to DC Inverter PS1A2
(Sheet 1 of 4)

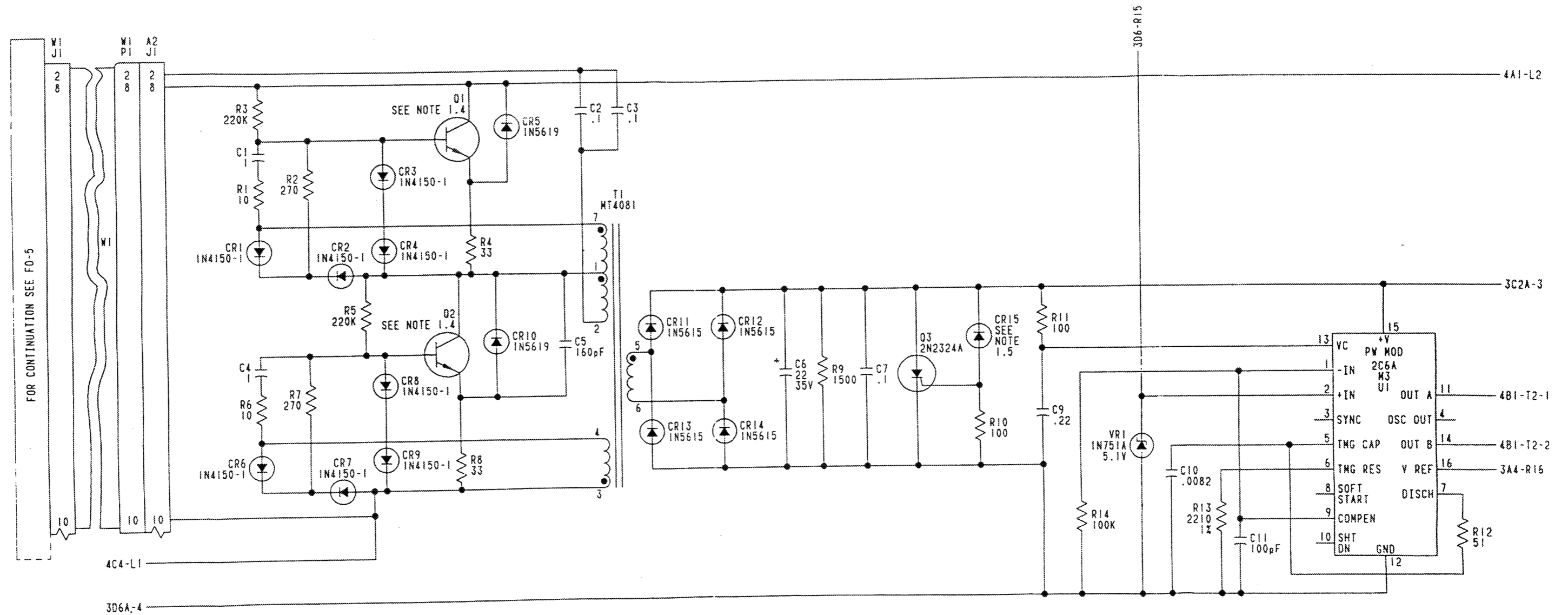

CEOJW-014

Figure FO-6. Schematic of PS AC to DC Inverter PS1A2 (Sheet 2 of 4)

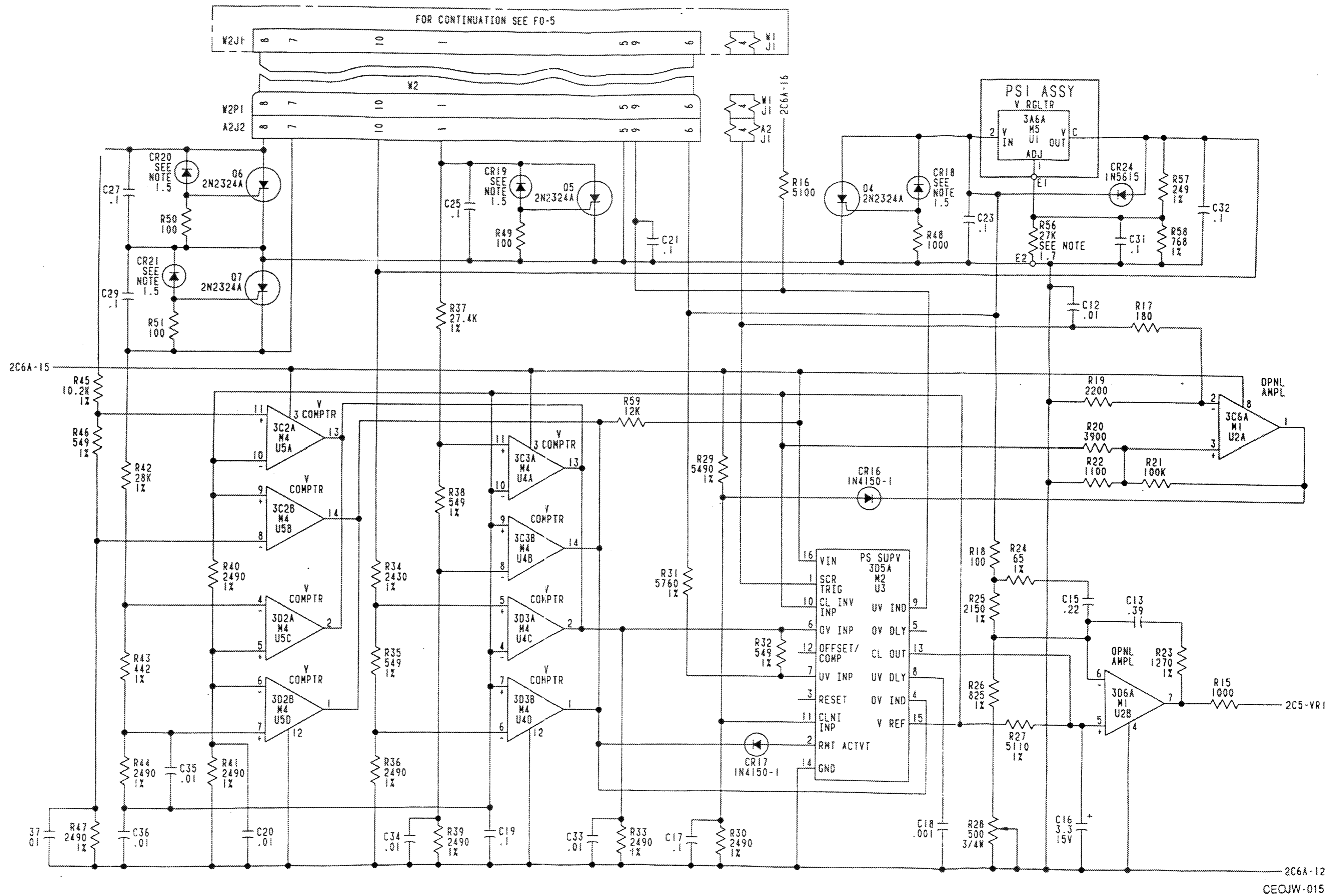
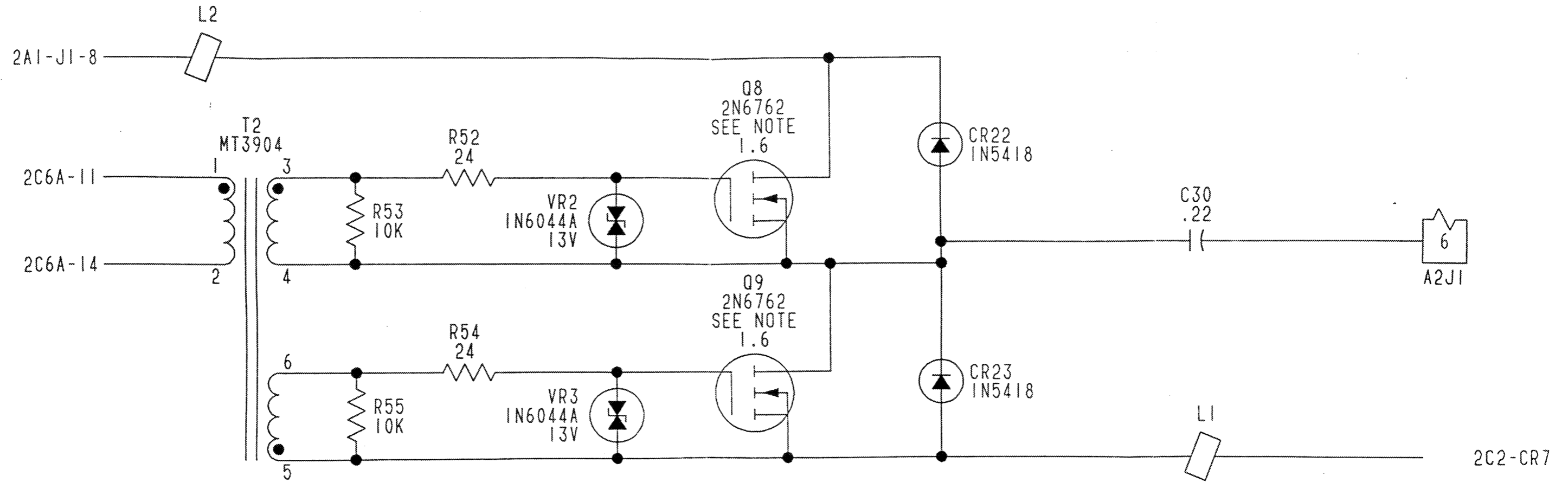

Figure FO-6. Schematic of PS AC to DC Inverter PS1A2 (Sheet 3 of 4)

2C6A-12
CEQJW-015



CEOJW-016

Figure FO-6. Schematic of PS AC to DC Inverter PS1A2 (Sheet 4 of 4)

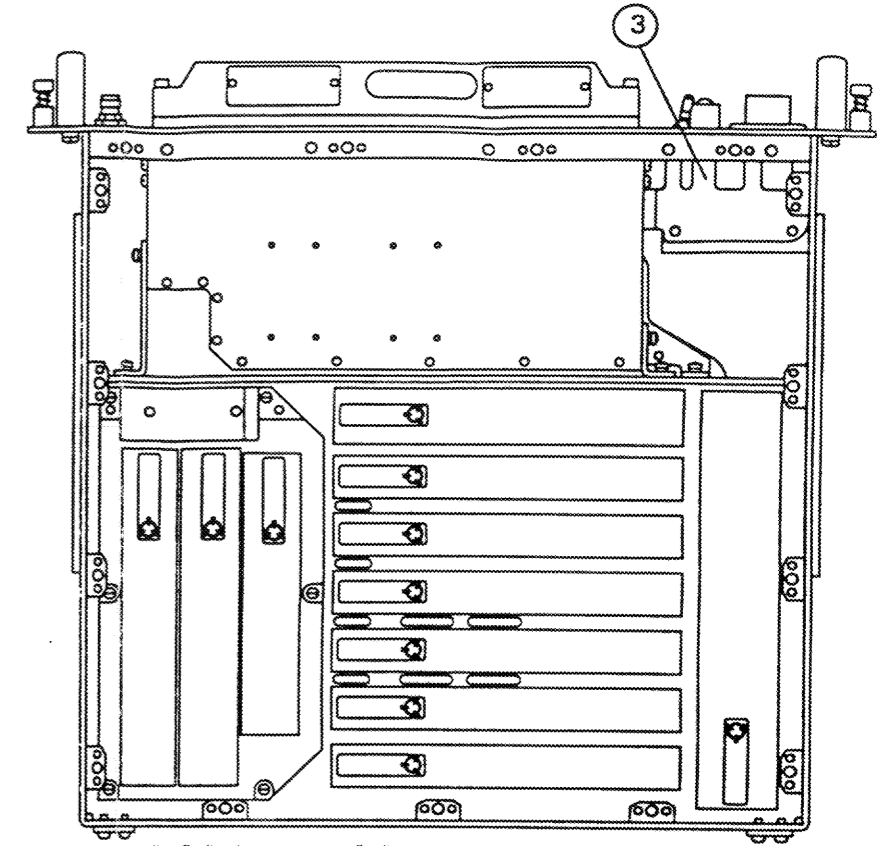

TOP VIEW COVER REMOVED

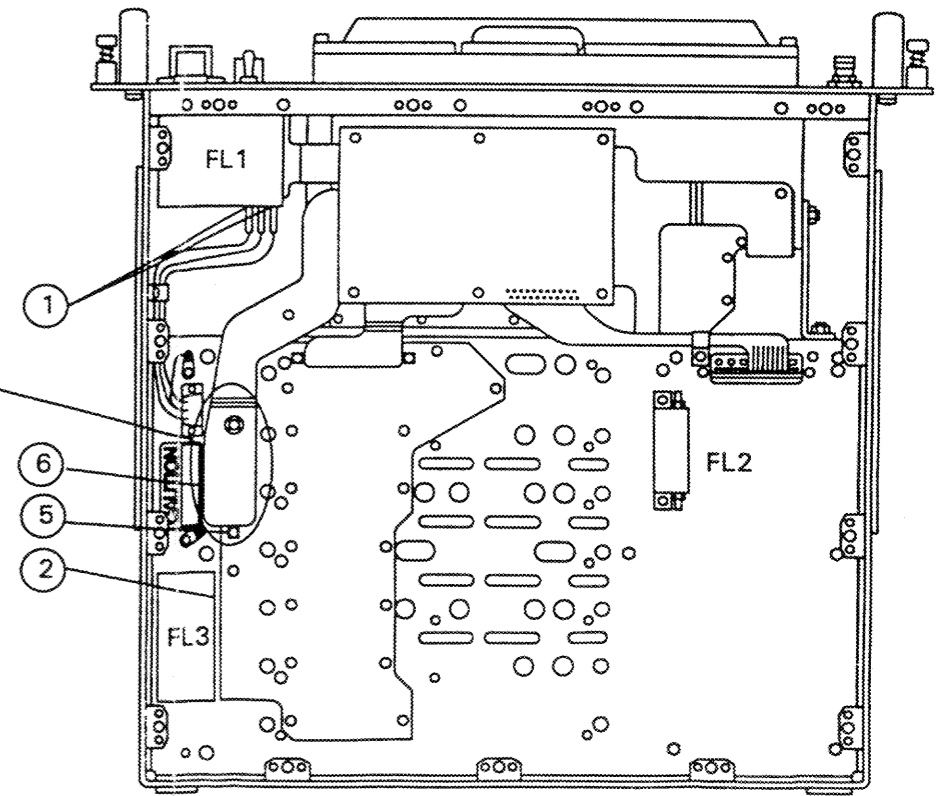
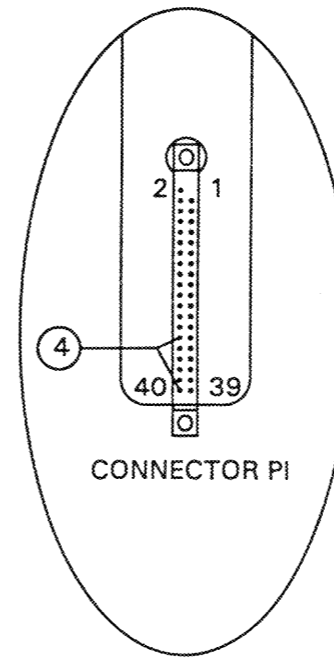

BOTTOM VIEW RT CHASSIS

CEOJW-017

Figure FO-7. RT Chassis Test Points

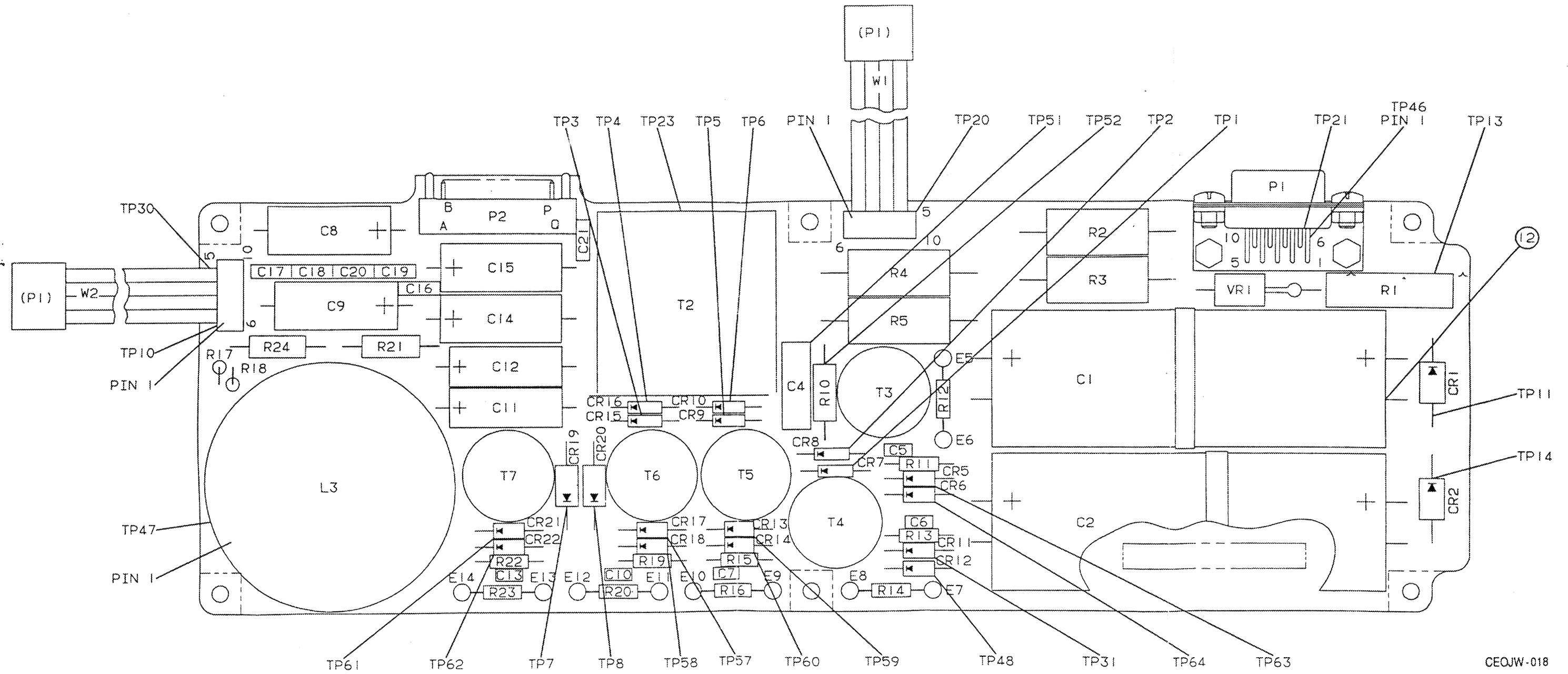

CEOJW-018

Figure FO-8. Test Points
for PS Regulator Output PS1A3
(Sheet 1 of 2)

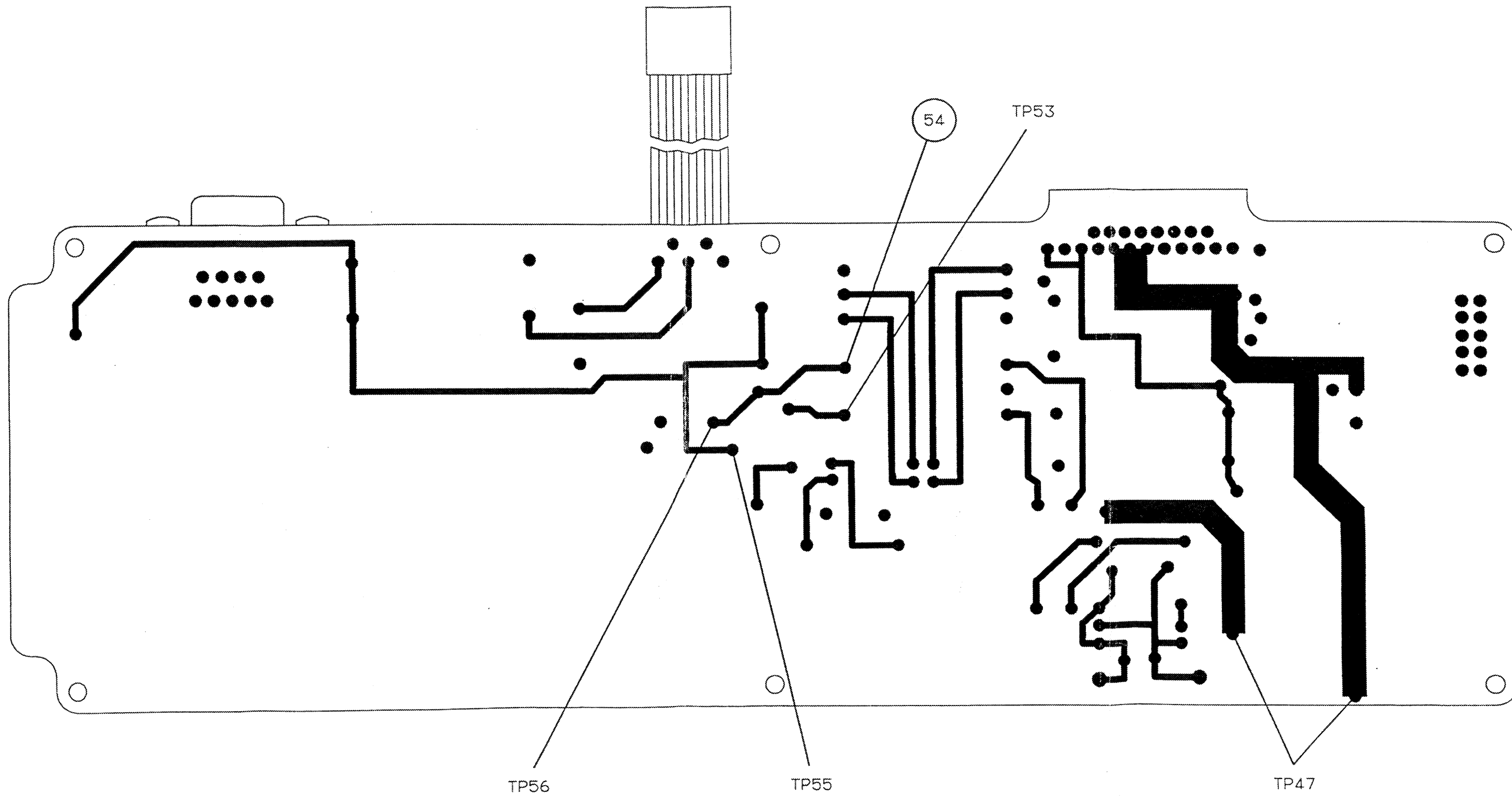

CEQJW-019

Figure FO-8. Test Points
for PS Regulator Output PS1A3
(Sheet 2 of 2)

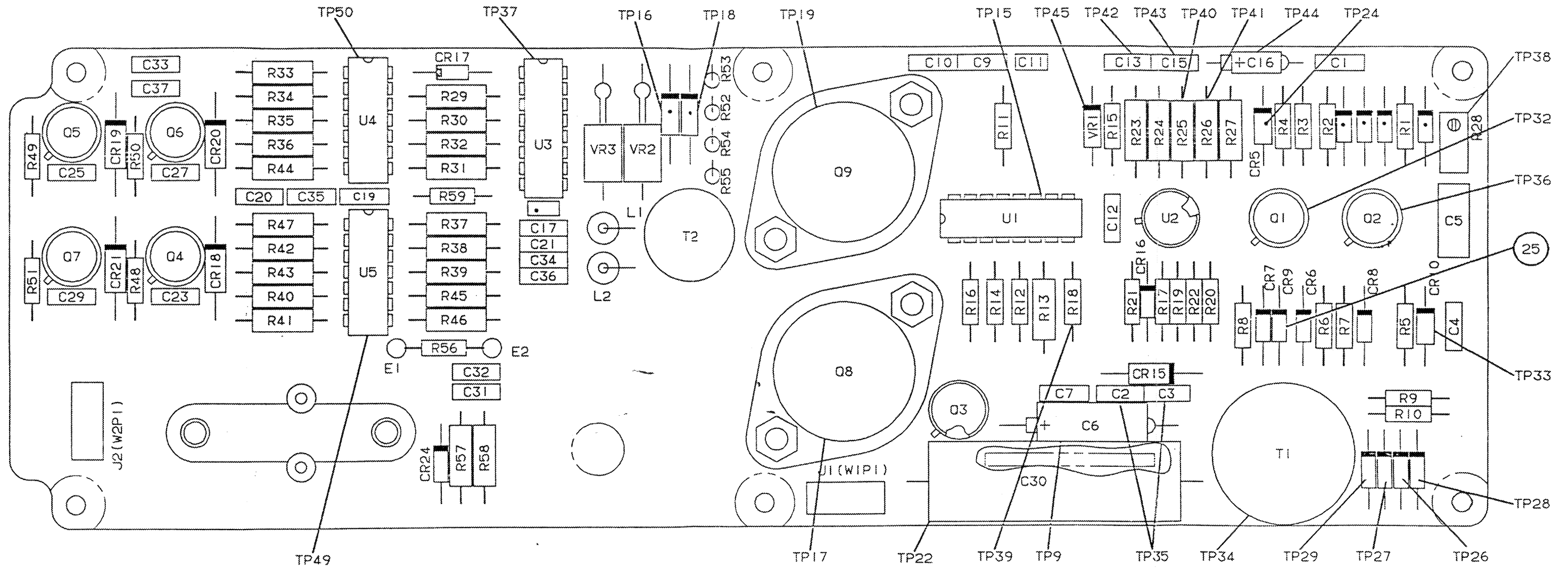

CEOJW-020

Figure FO-9. Test Points for PS AC to DC Inverter PS1A2