

American Communication Systems

Discover the Power of Communications™

TO ORDER – VISIT <http://www.ameradio.com>

HF-SSB MICOM-500E Model G761AA / G762AA

This manual is an appendix to the Micom 2E-Trunk Owner's Manual 6802952C60

HF-SSB MICOM-500E-A



Owner's Manual
6886858J01-A

CONTENTS

Introduction.....	2
General Specifications	2
Block diagram.....	3
Controls and indicators	4
General principles of operation.....	5
500W HF Linear Amplifier Unit	6
DC Power Supply	7
Junction Box	7
Performance Specifications	8
500W Transceiver Model Complements	11
Trouble Shooting	11
Radio Tuning Procedure	12
ALE.....	12

INTRODUCTION

The transceiver is a complete unit that includes Micom-2ET, 500watts amplifier , power supply, enclosed together in a 19” drawer. The control head of the radio is placed on the drawer’s front panel. The unit includes a movable drawer, which allows to detach the control panel of the radio and moved up to 5 meters away (cable extension included).

The transmitter amplifier is microprocessor controlled, doing the following functions:

- Adjust amplifier input sensitivity
- Monitor heat, VSWR, and under voltage conditions,
- Setting the power output via the channel power setting (Max, High, Medium and Low)

GENERAL SPECIFICATION

Power Output:	1.6-30MHz: 500W PEP and average
Band Switching:	Fully Automatic
Input Voltage:	220VAC-10A /110VAC-20A
Cooling:	Cooling fans
T/R Switching time:	10mS nominal
Band Switch time:	100mS nominal
Protection:	Input over drive under voltage (adjustable): Factory default 28+/-3 VDC Amplifier module Current imbalance VSWR faults Frequency out of Specified range over current over temperature.

MICOM-500W BLOCK DIAGRAM

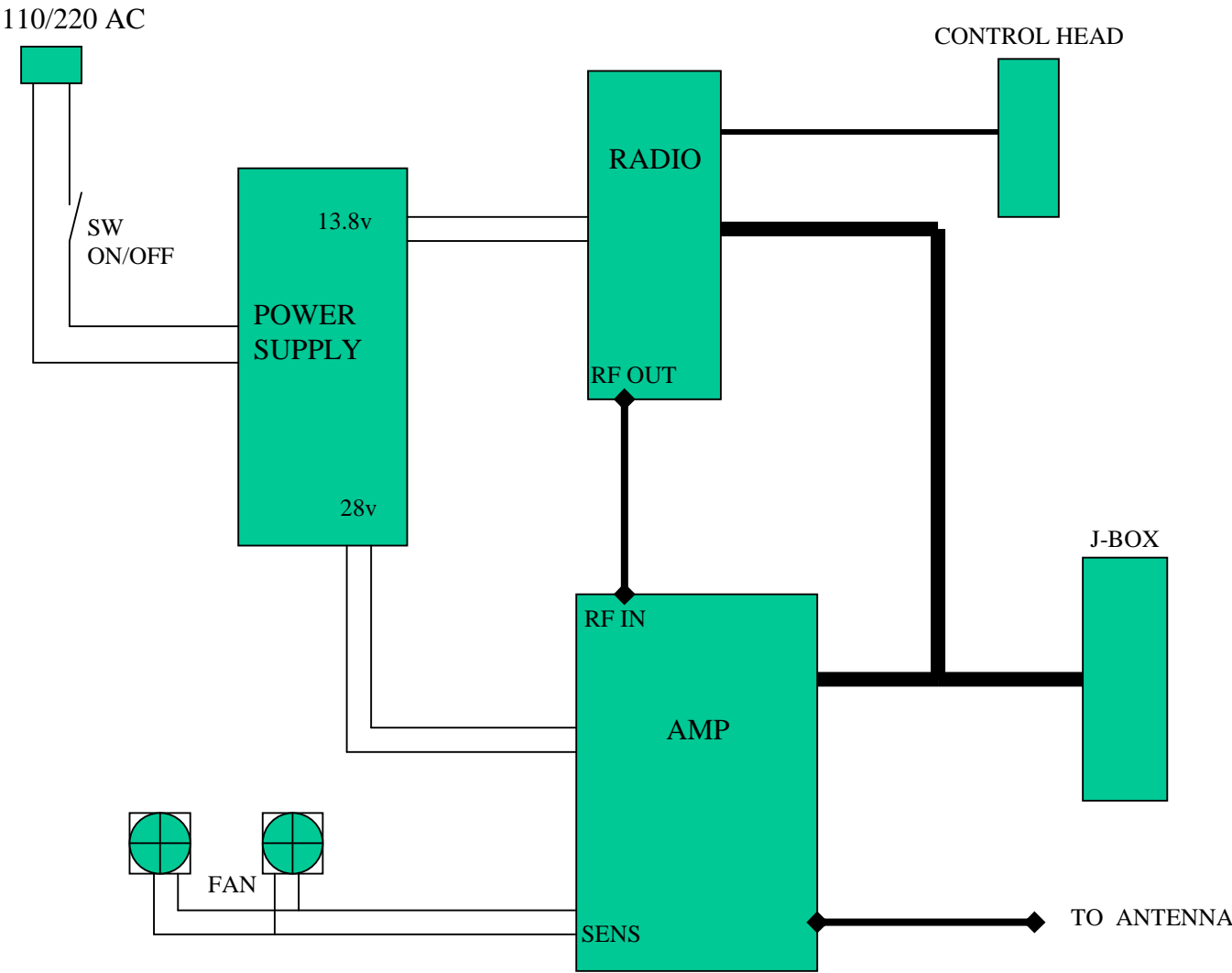

NOTE: ALL THE WIRES AND CABLES CAT No - 01MB000027

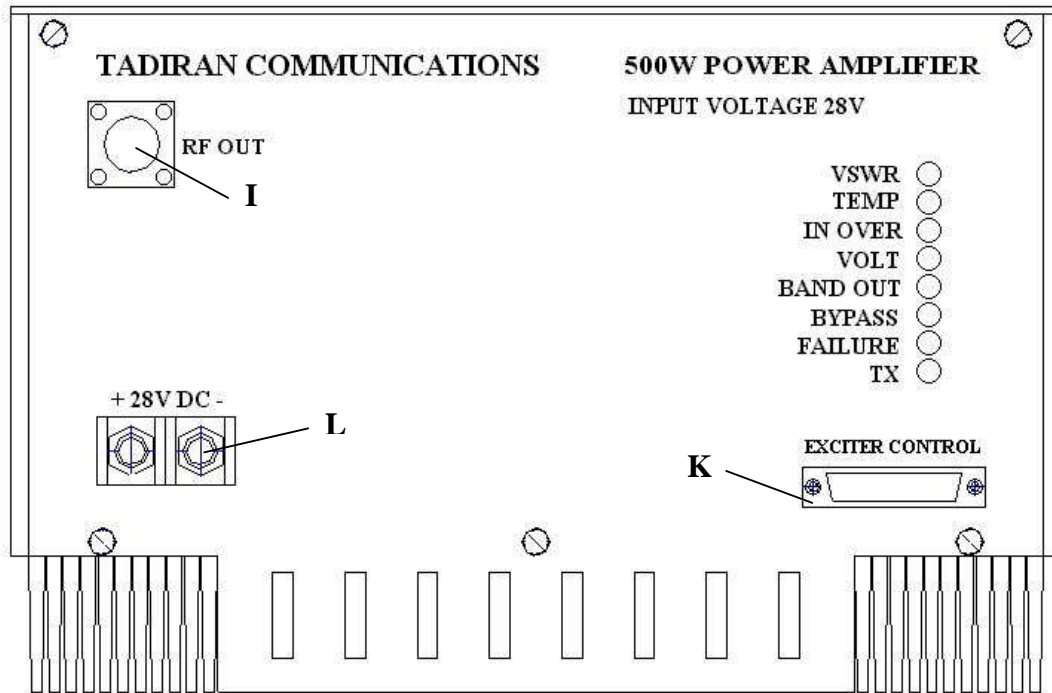

Figure 1. PA 500 front panel

Controls and Indicators

Power Amplifier module has the following controls and indicators:

Indicator VOLT – shows when power supply voltage is out of limits.

In OVER – input overload indicator. Input power is out of limits.

TEMP – amplifier overheat indicator.

VSWR – load circuit failure indicator.

FAILURE – fatal failure indicator, further amplifier operation is impossible.

TX – transmission mode indicator.

BYPASS – bypass mode indicator. The amplifier shall operate in this mode when it is disconnected to power supply, faulty, can not operate by any other reason or is in receive mode.

BAND OUT indicator shows that input signal frequency is out of operation band.

General principles of operation

Block diagram of the power amplifier is shown at Fig.4. Input RF signal with 25W nominal level comes through “RF In” connector to TS1 227 board of PAMP 500 amplifying device consisting of 4-channel power splitter and 4-channel amplifier. The power splitter unit contents:

- Input signal level sensor;
 - Input relay Rx/Tx that provides the possibility to operate in **BYPASS** mode;
 - Input signal attenuator used by the amplifier protection system;
 - Signal frequency sensor;
 - Power splitter.

The signal comes from power splitter output to four 150W amplifying sections inputs. Then, amplified signal is summed by power Combiner (TS5 226).

The signal then comes from Combiner output to harmonic filter (TS5 223) input and then to output level sensor, output relay Rx/Tx and to output connector “RF OUT”.

The controller provides the power amplifier control, status monitoring and its protection in emergency situations. By analyzing the input signal level, the controller provides protection of the amplifier input against overloading. By measuring the input signal frequency the controller selects and switches on appropriate harmonic filter. Control system also provides the control of the amplifier sink temperature. Depending of its level the forced air cooling system shall be switched on or output power level shall be reduced if necessary and if the temperature limit is exceeded the amplifier shall be switched to **BYPASS** mode. By analyzing signals from output sensor the controller monitors the status of load, and if VSWR in the load is higher than maximum allowed one the controller decreases output power, and if VSWR is higher than 4 the controller switches the amplifier to **BYPASS** mode. Besides, the controller sends to CONTROL output connector the signals that proportional to forward and reflected power at the amplifier output and that assigned for output power control from an external device, for example, exciter.

Thus, the amplifier control system provides full its status and operability control. It switches the amplifier to **BYPASS** mode in the following cases:

- VSWR > 1:4
- Input signal frequency is out of operation band
- The temperature mode is out of limits
- In other cases, as well as in switched off mode when normal operation of the amplifier is impossible. In that case the possibility of normal operation of external transceiver is provided.

MICOM 2E-Trunk

For Micom 2E-Trunk specification see user manual 6802952C60

500W HF Linear Amplifier Unit

Input Voltage: 28 VDC
Power Output: 1.6-30MHZ: 500W PEP and average

The power amplifier is fully protected by microprocessor control. This circuitry dynamically monitors all amplifier parameters, and provides adjustments and protection against high VSWR, under voltage, over current and high temperature conditions.

Current- protection against over current condition (exceeding 60 amps) and current imbalance between amplifier modules (exceeding 20%). When one of these two conditions exists, the amplifier turns off-line. To reset the transceiver, power down the amplifier and restart the unit.

Volt - protection against under amplifier turns off-line. To reset the transceiver, power down the amplifier and restart the voltage condition (less than 28+/-3 VDC). When this condition exists, the unit.

VSWR – when a sampled VSWR exceeded 4:1 and the power reflected back to the amplifier is higher than acceptable, the amplifier turns off-line. To reset the transceiver, power down the amplifier and restart the unit.

Temp - protection against over temperature condition

Atten – as input RF power level increases beyond 60-70 watts, the attenuation increases automatically. The Attenuate remains engaged until the input drops to 30 watts.

ALC Control- provides adjustable ALC feedback voltage.

A positive voltage is present on the Amplifier line for use with the equipped transceiver for ALC input control.

PTT keying mode and Band input filter selection enabled automatically. Band switching time is typically 100 msec or less.

This automated capability is ideal for remote or unattended operating site application.

3. DC Power Supply

Model: EWS1500-15
Nominal Output Voltage: 28V-50A----14V-30A
Input Voltage Range: 85~132 VAC / 170~265 VAC (Auto Selectable), 47~63 Hz

110/220 VAC power supply - if need to convert the power supply from 220VAC to 110VAC, please detached the 110/220VAC panel at the rear panel of the unit and short the A and B terminals.

The ON/OFF switch on the front panel of the unit, enables to turn the power supply output on and off.

Note that, when the dc output power supply is on OFF mode, the internal power supply fans still work.

4. Junction Box

The junction box enables the connection of up to four external devices simultaneously, in addition to headphone, to the accessory port of the MICOM –2 (e.g. modem, phone patch.)

Potentiometers adjust - Potentiometers are used to adjust the received audio levels (one of each connector). Each potentiometer is associated with a connector as follows:

ACC. -J1: RX1
ACC. -J2: RX2
ACC. -J3: RX3
ACC. -J4: RX4

The potentiometers are located on the rear panel of the MICOM-500E.
For more details see Service Manual 68P02952C55

PERFORMANCE SPECIFICATIONS for 500W TRANSCEIVER

GENERAL

Frequency Range XMIT	1.6 – 30 MHz
Frequency Range RX	0.1 – 30 MHz (0.1 - 1.6 MHz reduced spec)
RF Input Impedance	50 Ohms
Number of Channels	200 SIMPLEX or HALF DUPLEX
Scanning ¹	5 groups with up to 100 channels per group, including 1 guard channel. Programmable scan rate: 1 - 5 sec. per channel, in 1 sec. steps
Frequency Stability	0.6 PPM @ -10° to 60°C
Frequency Drift (Aging)	1 PPM/year
Synthesizer Lock Time	10 msec. Max
Frequency Resolution	10 Hz
Operating Temp. Range	-10° to +60°C
Storage Temp. Range	-30° to +70°C
Humidity	95% @ 50°C
Remote Control Interface	RS232C (Optional)
Modes of Operation	J3E SSB R3E PILOT H3E AME J2A CW J2B RTTY, ARQ, FEC, PACKET, MCW B8C FAX, DATA, FSK

Dimensions

Height (mm/inch)	265/10.43
Width (mm/inch)	422/16.61
Depth (mm/inch)	508/20

CURRENT CONSUMPTION @ 14 VDC / 28VDC (INTERNAL CURRENT)

XMIT	Voice (500 W P.E.P.)	38 Amp
Receive	Full Audio	2 Amp
	Squelch	1.7 Amp

¹ ALE specification see user manual 6802952C60

TRANSMITTER

Output Power	500W P.E.P. and average +/-1dB
Reduced Power Levels	500W, 400W, 300W, 200W (RSS programmable)
Audio Bandwidth ²	350 to 2700 Hz at -6dB
Audio Bandwidth Ripple	3 dB
Intermodulation	-31 dB / 500W P.E.P
Spurious Emissions	-60 dB / 500W P.E.P
Carrier Suppression	-50dB / 500W P.E.P
Undesired Sideband Suppression	-55dB / 500W P.E.P
Audio Distortion	2.5%
1/2 Power Mic. Sensitivity	15 to 125mV (RMS)/600 Ohms
Hum & Ripple	-50 dB
Inband Noise	-60 dB (30 Hz BW)
TX/RX Switching Time	10 msec
Tx Tuning Adjustments ³	None

RECEIVER

Sensitivity (SINAD) SSB	0.5 μ V for 10 dB SINAD (0.35 μ V Typical. Note 1) 0.1 - 1.6 MHz with reduced performance
1/2 Rated Power Sensitivity	1 μ V for 2.5W audio at speaker
Selectivity ²	- 6 dB @ 350 to 2700 Hz -60 dB @ -1 kHz; +4 kHz
Image Rejection	-80 dB
IF Rejection	-85 dB

RECEIVER (continued)

² See Micom 2E spec. for more Bands widths.

³ For tune procedure wait about 2 sec when stepping from one channel to another before transmitting.

Undesired Sideband Rejection	-55 dB @ -1 kHz
Spurious	-80 dB
Intermodulation	-80 dB
Crossmodulation	-100 dB @ 100 kHz
Desensitization	-100 dB @ 100 kHz
Reciprocal Mixing	-100 dB @ 100 kHz
Audio Power at Speaker	5W @ 2.5% distortion
RGC Range	5 μ V to 1V (2 dB change in output level)
RGC Time Constants	Attack time 10 msec
Voice	Release time 1500 msec
Data	Attack time 10 msec Release time 10 msec
Squelch	Constant SINAD (digital)
Clarifier Range	\pm 200 Hz
Receiver Tuning Adjustments	None
Maximum Antenna Input	20 kV transient, 100V RMS for 2 minutes

CONTROLS

Standard and optional: volume, on/off, scroll, squelch, scan, USB/LSB, call, monitor, priority, func and accessory/programming connector.

Specifications subject to change without notice.

500W TRANSCEIVER MODEL COMPLEMENTS

M81AMN0KV5AK *	MICOM-2ET
FDN6144A	Amplifier 500 watts
FPN5585A	Power supply
FRN5865A	Junction box
01MB000027	Cables
01MB000029	Chassis
01MB000030	Miscellaneous
FMN1615A	Microphone

*** NOTE:**

LORD No-FLN3170A
 HIGH POWER NO-FLN3180A with interface modification for 500w amplifier

TROUBLE SHOOTING

In case of malfunctioning, perform the following steps (refer to the Maintenance section in MICOM-2E Owner's manual, Motorola publication number 6802952C60).

1. Turn OFF and ON the radio switch to reset both the radio and the amplifier.
 2. Use BITE when the channel is in SSB mode only
 3. Refer to the User Troubleshooting Chart.
 4. Follow the troubleshooting procedures in this section, which provide instructions for isolating faulty boards.
- Troubleshooting a board at component level should be performed according to the notes on the relevant schematic diagram.

FAULT	ADVICE
VOLT trip off-line	Ensure power supply maintains voltage greater than 11.0VDC <i>under load</i> . Check DC cable connections.
VSWR trip off-line	Check integrity of antenna and feedline connections. Check for evidence of arc-over or dielectric breakdown of feedline. Ensure antenna is resonant (<2:1 SWR) at the desired operating frequency.
Amp TEMP led is on.	Reduce drive level or duty-cycle. Ensure fan unit is operating properly.
No PTT Keying	Ensure transceiver, amplifier and DC supply all utilized a common ground.

RADIO TUNING PROCEDURE

Before operating the 500W transceiver, a calibration procedure should be taken. An IBM PC and RSS (Radio Service Software) package, FLN2514, are required to align the radio.(factory setting)

1. On the accessories section, please mark the check box of the “1 kw Amplifier”.
2. There are 4 steps of power outputs as noted above. If you need to perform a power calibration, please refer to the power calibration procedure in the MICOM-2E RSS manual.

ALE

Automatic Link Establishment (ALE) is an embedded feature inside the Micom-2E/R ALE family of mobile/fixed station HF-SSB radios.

Through the combined use of channel scanning, selective calling and Link Quality Analysis, ALE automatically selects the best available communications link. It is no longer necessary for an operator to be familiar with the varying factors, which affect high frequency (HF) propagation between two points.

Each ALE equipped Micom-2 ALE family radio stores a matrix of Link Quality Analysis (LQA) scores for all other stations in the HF network. Memorized LQA scores are derived from an analysis of channel "soundings" which are periodically transmitted by each network station. When an operator selects the individual or net call address of the receiving station, ALE automatically determines the optimum available channel and automatically initiates calling procedures. Sending and receiving operators are alerted when a communication link has been established.