

# MARINE CORPS TM 07748B-45/2 ARMY TM 11-5820-1046-40

CHANGE 1 INCLUDED

## TECHNICAL MANUAL GENERAL SUPPORT AND DEPOT MAINTENANCE MANUAL

FOR

### RADIO SET AN/PRC-104B(V)1 ,(V)4 (NSN 5820-01-269-5603) (NSN 5820-01 -262-9550)

Hughes Aircraft Company  
Ground Systems Group  
Fullerton, California

N00039-87-C-021

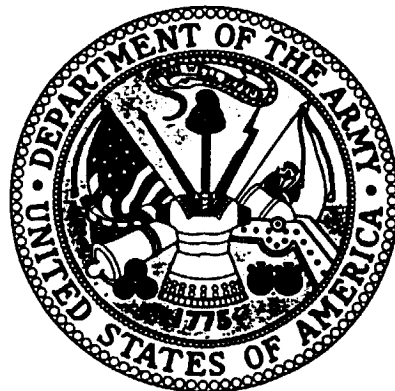

This document required for official use or for administrative purposes only.  
Distribution authorized to U.S. Government Agencies only. Other requests  
for this document must be referred to: Commandant of the Marine Corps  
ARS-B1 Washington, D.C. 20380-0001 or Commander, U.S. Army  
Communications Electronics Command, ATTN AMSEL-LC-ME-P, Fort  
Monmouth, N.J. 07703-5000.

Destroy by any method that will prevent disclosure of contents or  
reconstruction of document.

HEADQUARTERS, U.S. MARINE CORPS  
HEADQUARTERS, DEPARTMENT OF THE ARMY

FEBRUARY 1989

INTRODUCTION 1-1
PRINCIPLES OF OPERATION 2-1
RADIO SET GENERAL DESCRIPTION 2-5
DETAILED FUNCTIONAL DESCRIPTION 2-9
FABRICATION OF SPECIAL SUPPORT 3-17 EQUIPMENT
MAINTENANCE DATA FOR 3-25 ACCESSORIES
RT TROUBLESHOOTING 4-3
AMPLIFIER/COUPLER TROUBLESHOOTING 5-3
RT FAULT ISOLATION 6-1
RT COMPONENT LOCATION 6-45
RT SCHEMATIC DIAGRAMS 6-57
AMPLIFIER/COUPLER 7-1 FAULT ISOLATION
AMPLIFIER/COUPLER 7-17 COMPONENT LOCATION
AMPLIFIER/COUPLER SCHEMATIC 7-23 DIAGRAMS

18407748200



TM 07748B-45/2

PCN 184 077482 00

**BLANK  
INTENTIONALLY**

DEPARTMENT OF THE NAVY  
HEADQUARTERS, UNITED STATES MARINE CORPS  
WASHINGTON, DC 20380-0001

TM 07748B-45/2  
Change 1  
PCN 184 077482 01

17 August 1992

1. Purpose. To transmit pen changes to the basic Manual, TM 07748B-45/2, dated February 1989, General Support and Depot Maintenance Manual for Radio Set AN/PRC-1043B(V) 1,(V)4, NSN's 5820-01-269-5603 and 5820-01-262-9550.

2. Action. Make the following changes:

PAGE

a, 4-7, 6-1

ACTION

Add the following warning to the indicated pages:

**WARNING**

Components A1A1A1U1,A1A1A2U1 AND A1A1A3AR3 may contain Beryllium

**BERYLLIUM PRODUCT (BeO)**

**DUST OR FUMES HAZARDOUS IF INHALED OR INGESTED. THIS PRODUCT CONTAINS BERYLLIUM. DO NOT SAW, GRIND, SANDBLAST, MACHINE OR PERFORM OTHER OPERATIONS ON THIS PRODUCT WHICH WILL PRODUCE BERYLLIUM DUST. DO NOT PROCESS THIS MATERIAL IN MOIST ATMOSPHERES AT TEMPERATURES IN EXCESS OF 700 DEGREE C NOR PLACE IN ACIDS THAT WILL PRODUCE BERYLLIUM FUMES**

3. Filing Instructions. This Change transmittal page will be filed immediately following the signature page of the basic Manual.

BY DIRECTION OF THE COMMANDANT OF THE MARINE CORPS

OFFICIAL

  
R. W. PRICE  
Executive Director  
for Logistics operations  
Marine Corps Logistics Bases  
Albany, Georgia 31704-5000

DISTRIBUTION: PCN 184 077482 01

1/(2 blank)

BLANK  
INTENTIONALLY

TM 07748B-45/2  
TM 11-5820-1046-40

DEPARTMENT OF THE NAVY  
Headquarters, U.S. Marine Corps  
Washington, D.C. 20380-0001

1 February 1989

1. This Manual is effective upon receipt and contains General Support and Depot Maintenance Instructions for the AN/PRC-104B Radio Set.
2. Notice of discrepancies or suggested changes should be forwarded on NAVMC 10772 to: Commander, Marine Corps Logistics Bases (Code 850), Albany, Georgia 31704-5000.

BY DIRECTION OF THE COMMANDANT OF THE MARINE CORPS

OFFICIAL:

*R. W. Falkenbach*

Colonel R. W. Falkenbach  
Director, Program Support  
Marine Corps Research, Development, and Acquisition Command

By Order of the Secretary of the Army:

CARL E. VOUNO  
General, United States Army  
Chief of Staff

OFFICIAL:

WILLIAM J. MEEHAN II  
Brigadier General, United States Army  
The Adjutant General

DISTRIBUTION: PCN 184 077482 00

# BLANK INTENTIONALLY



**SAFETY SUMMARY (1 of 2)**

The following are general safety precautions that are not related to any specific procedures and therefore do not appear elsewhere in this publication. These are recommended precautions that personnel must understand and apply during many phases of operation and maintenance.

**WARNING**

Dangerous voltages exist at the radio antennas on the shelter when the radio sets are operating. Do not touch these antennas. Observe the precautions given in TB SIG 291 concerning vehicular whip antennas.

**CAUTION**

THIS EQUIPMENT CONTAINS PARTS AND ASSEMBLIES SENSITIVE TO DAMAGE BY ELECTROSTATIC DISCHARGE (ESD). USE ESD PRECAUTIONARY PROCEDURES WHEN TOUCHING, REMOVING OR INSERTING PRINTED CIRCUIT BOARDS.



**5**

SAFETY STEPS TO FOLLOW IF SOMEONE IS THE VICTIM OF ELECTRICAL SHOCK

**1**

DO NOT TRY TO PULL OR GRAB THE INDIVIDUAL

**2**

IF POSSIBLE, TURN OFF THE ELECTRICAL POWER

**3**

IF YOU CANNOT TURN OFF THE ELECTRICAL POWER, PULL, PUSH, OR LIFT THE PERSON TO SAFETY USING A WOODEN POLE OR A ROPE OR SOME OTHER INSULATING MATERIAL

**4**

SEND FOR HELP AS SOON AS POSSIBLE

**5**

AFTER THE INJURED PERSON IS FREE OF CONTACT WITH THE SOURCE OF ELECTRICAL SHOCK, MOVE THE PERSON A SHORT DISTANCE AWAY AND IMMEDIATELY START ARTIFICIAL RESUSCITATION

**SAFETY SUMMARY (2 of 2)**

The following warnings appear in the text of this volume and are repeated here for emphasis.

**WARNING**

Vapors emitted during certain circuit card repair procedures may be irritating to personnel. Always perform circuit card repair procedures in a well-ventilated area. (Pages 3-4 and 3-12)

**WARNING**

Isopropyl alcohol is flammable. Keep away from heat and open flame. Vapors may be harmful. Use with adequate ventilation. Avoid prolonged or repeated breathing of vapor. Avoid eye contact. Do not take internally. (Pages 3-5 and 3-6)

**WARNING**

Adhesives are irritating to the skin and eyes upon contact, and may emit harmful vapor. Use only with adequate ventilation. Avoid all skin and eye contact. Use protective clothing such as rubber gloves, apron, and eye protection. Wash off immediately any accidentally contaminated skin area. Hand-washing facilities and eye-wash fountain should be provided. Do not take internally. (Pages 3-5, 3-6, 3-9, 3-10, 3-11, and 3-12)

**WARNING**

Handling hot items presents a serious injury potential. Asbestos gloves are required. (Pages 3-5, 3-6, 3-8, 3-10, and 3-12)

**WARNING**

Polyurethane contains flammable solvents and toxic diisocyanates. Keep away from heat and open flame. Vapors or mists are harmful. Complete body protection, including entire head, is required to prevent skin or eye irritation from contact with the paint or its vapors or mists. Respirator protection is required, usually an air-supplied hood, during mixing, curing and application. Use this paint only with the protection requirements as specified above. Suitable flushing facilities must be provided for immediate clean water flushing or any accidental skin or eye contact. Do not take internally. (Page 3-6)

**WARNING**

Drilling operations create metal chips that may enter the eyes and cause serious injury. Eye protection is required. (Page 3-6)

**WARNING**

Toluene is flammable. Keep away from heat and open flame. Vapors are harmful. Use only with adequate ventilation. Avoid prolonged or repeated breathing of vapor. Avoid contact with skin and eyes. Do not take internally. Comply with air pollution control rules concerning photochemically reactive solvents. (Page 3-6)

**WARNING**

Solvents used in this procedure are flammable and must be kept from open flame, heat, and sparks. Keep containers tightly closed and store them in a cool place when not being used. The solvent must be used only in an adequately ventilated environment. Avoid breathing vapors and repeated contact with skin. Clean hands thoroughly before smoking, eating or drinking. (Page 3-8)

**WARNING**

Use Freon in an adequately ventilated area. Avoid prolonged or repeated breathing of vapor. Avoid contact with skin and eyes. Do not take internally. (Pages 3-9, 3-11, and 3-12)

**WARNING**

When using a compressed airjet, use eyeshields. (Page 3-14)

**WARNING**

When using solvents provide proper ventilation avoid prolonged contact, and do not smoke. Solvents must meet all pertinent specifications regarding toxicity, flammability and allergenic effect. (Page 3-1 4)

**WARNING**

De-energize equipment before removing or replacing (assembly, module, or cable). (Pages 4-8 thru 4-18, 5-8 thru 5-10, and 5-12 thru 5-14)



**TABLE OF CONTENTS**

	Page		Page
CHAPTER 1 <b>INTRODUCTION</b> .....	1-1	Section III RT Disassembly and Reassembly .....	4-7
Section I General Information .....	1-1	CHAPTER 5 AMPLIFIER/COUPLER Maintenance .....	5-1
Section II Equipment Description and Data .....	1-3	Section I Introduction and Tools .....	5-1
CHAPTER 2 THEORY OF OPERATION .....	2-1	Section II <b>Amplifier/Coupler Troubleshooting</b> .....	5-3
Section I <b>Principles of Operation</b> .....	2-1	Section III Amplifier/Coupler Disassembly and Reassembly .....	5-7
Section II <b>Radio Set General Description</b> .....	2-5	CHAPTER 6 RT DEPOT MAINTENANCE .....	6-1
Section III <b>Detailed Functional Description</b> .....	2-9	Section I <b>RT Fault Isolation</b> .....	6-1
Section IV Power Distribution .....	2-53	Section II <b>RT Component Location</b> .....	6-45
CHAPTER 3 GENERAL Maintenance .....	3-1	Section III <b>RT Schematic Diagrams</b> .....	6-57
Section I Circuit Card Assembly Repair Procedures (Marine Corps Only) .....	3-1	CHAPTER 7 AMPLIFIER/COUPLER DEPOT MAINTENANCE .....	7-1
Section II Cleaning and Examination .....	3-13	Section I <b>Amplifier/Coupler Fault Isolation</b> .....	7-1
Section III <b>Fabrication of Special Support Equipment</b> .....	3-17	Section II <b>Amplifier/Coupler Component Location</b> .....	7-17
Section IV Performance Test and Troubleshooting .....	3-21	Section III <b>Amplifier/Coupler Schematic Diagrams</b> .....	7-23
Section V <b>Maintenance Data for Accessories</b> .....	3-25	<b>APPENDIX</b> REFERENCES .....	A-1
CHAPTER 4 RT MAINTENANCE .....	4-1	GLOSSARY .....	Glossary-
Section I Tools and Test Equipment .....	4-1	INDEX .....	Index-1
section II <b>RT Troubleshooting</b> .....	4-3		

LIST OF ILLUSTRATIONS

Figure	Title	Page	Figure	Title	Page
1-1	Radio Set AN/PRC-104 .....	1-1	5-8	Ground A2E1 and Latch Removal and Replacement .....	5-14
1-2	Radio Set Description .....	1-3	6-1	EFP Fault Isolation Performance Test Setup .....	6-2
2-1	Transmit Operation .....	2-3	6-2	Modulator/Demodulator Fault Isolation Performance Test Setup .....	6-9
2-2	Receive Operation .....	2-4	6-3	First Frequency Converter Fault Isolation Performance Test Setup .....	6-19
2-4	Power Amplifier (2 Sheets) .....	2-11	6-4	Synthesizer Fault Isolation Performance Test Setup .....	6-25
2-5	Antenna Tuner .....	2-15	6-5	Harmonic Filter Fault Isolation Performance Test Setup .....	6-31
2-6	Front Panel Assembly .....	2-17	6-6	Harmonic Filter Fault Isolation Alignment Procedure .....	6-37
2-7	Control Interface Assembly (3 Sheets) .....	2-19	6-7	Power Supply Fault Isolation Performance Test Setup .....	6-40
2-8	Audio Filter Assembly .....	2-25	6-8	EFP Component Location (3 Sheets) .....	6-46
2-9	Synthesizer (2 Sheets) .....	2-27	6-9	Synthesizer Component Location .....	6-49
2-10	70/80 MHz Voltage-Controlled Oscillator (VCO) .....	2-30	6-10	Modulator/Demodulator Component Location .....	6-50
2-11	77-105 MHz Voltage-Controlled Oscillator (VCO) .....	2-30	6-11	First Frequency Converter Component Location .....	6-51
2-12	Ramp Generator .....	2-31	6-12	Second Frequency Converter Component Location .....	6-52
2-13	5-MHz Converter .....	2-31	6-13	Third Frequency Converter Component Location .....	6-53
2-14	Modulator/Demodulator .....	2-33	6-14	Harmonic Filter Component Location .....	6-54
2-15	Audio Control Hybrid (3 Sheets) .....	2-35	6-15	Power Supply Component Location .....	6-55
2-16	Automatic Level Control .....	2-41	6-16	RT Schematic Diagram (2 Sheets) .....	6-58
2-17	Frequency Converters (3 Sheets) .....	2-43	6-17	EFP Schematic Diagram (5 Sheets) .....	6-60
2-18	Harmonic Filter .....	2-49	6-18	Synthesizer Schematic Diagram (5 Sheets) .....	6-65
2-19	Power Supply .....	2-51	6-19	Ramp Generator Schematic Diagram (2 Sheets) .....	6-70
2-20	Power Distribution Description .....	2-54	6-20	70/80 MHz Voltage-Controlled Oscillator (VCO) Schematic Diagram (2 Sheets) .....	6-72
4-1	Test Setup .....	4-3	6-21	77-105 MHz Voltage-Controlled Oscillator (VCO) Schematic Diagram (2 Sheets) .....	6-74
4-2	Modulator/Demodulator A1A1 Removal and Replacement .....	4-9	6-22	Modulator/Demodulator Schematic Diagram (2 Sheets) .....	6-76
4-3	Harmonic Filter A1A2 Removal and Replacement .....	4-10	6-23	First Frequency Converter Schematic Diagram .....	6-78
4-4	Synthesizer AI A3 Removal and Replacement .....	4-11	6-24	Second Frequency Converter Schematic Diagram .....	6-79
4-5	Electronic Front Panel (EFP) A1A4 Removal and Replacement .....	4-12	6-25	Third Frequency Converter Schematic Diagram .....	6-80
4-6	Power Supply A1A5 Removal and Replacement .....	4-13	6-26	Harmonic Filter Schematic Diagram .....	6-81
4-7	Cable W2, W3, and W4 Removal and Replacement .....	4-14	6-27	Power Supply Schematic Diagram .....	6-82
4-8	W5 and W6 Removal and Replacement .....	4-16	7-1	Power Amplifier Fault Isolation Performance Test Setup .....	7-2
4-9	Cable W1 P2 Removal and Replacement .....	4-18	7-2	Antenna Tuner Fault Isolation Performance Test Setup .....	7-9
5-1	Amplifier/Coupler Power Distribution .....	5-4	7-3	Antenna Tuner Fault Isolation Alignment Procedure .....	7-15
5-2	Amplifier/Coupler RF Cabling .....	5-4	7-4	Power Amplifier Component Location (2 Sheets) .....	7-18
5-3	Test Setup .....	5-5	7-5	Antenna Tuner Component Location (2 Sheets) .....	7-20
5-4	Power Amplifier A2A1 Removal and Replacement .....	5-8	7-6	Amplifier/Coupler Schematic Diagram .....	7-24
5-5	Antenna Tuner A2A2 Removal and Replacement .....	5-9	7-7	Power Amplifier Schematic Diagram (2 Sheets) .....	7-25
5-6	Ribbon Cable A2W1 Removal and Replacement .....	5-11	7-8	Antenna Tuner Schematic Diagram (2 Sheets) .....	7-27
5-7	Antenna Mount, BNC Connector A2J1, and Antenna Select Switch A2S1 Removal and Replacement .....	5-13			

# CHAPTER 1 INTRODUCTION

## Section L GENERAL INFORMATION

### SCOPE, fig 1-1

This manual provides general support and depot maintenance information for the Radio Set AN/PRC-104(B), (V)1, (V)4 (radio set) and two of its compact subunits: the RT-1 209A Receiver/Transmitter (RT) and the AM-6874 Amplifier/Antenna Coupler (amplifier/coupler). The battery pack (battery pack) is maintained entirely at the organizational level and is covered in the Operator's and Organizational Maintenance Manual, USMC TM 07748B-12/1 / USA TM 11-5820-1046-12.

The radio set is a 20-watt manpack hf transceiver.

#### NOTE

Army maintenance philosophy limits maintenance to removal and replacement of modules. Repair beyond that level must be performed at depot only. Depot will be performed by Marine Corps only.

### MAINTENANCE FORMS, RECORDS, AND REPORTS

Department of the Army forms and procedures used for equipment maintenance will be those prescribed by TM38-750, The Army Maintenance Management System.

Marine Corps personnel will use TM 4700-15/1 (Equipment Record Procedures).

### DESTRUCTION OF MATERIEL TO PREVENT ENEMY USE

Destruction of Army materiel to prevent enemy use will be in accordance with TM 750-244-2.

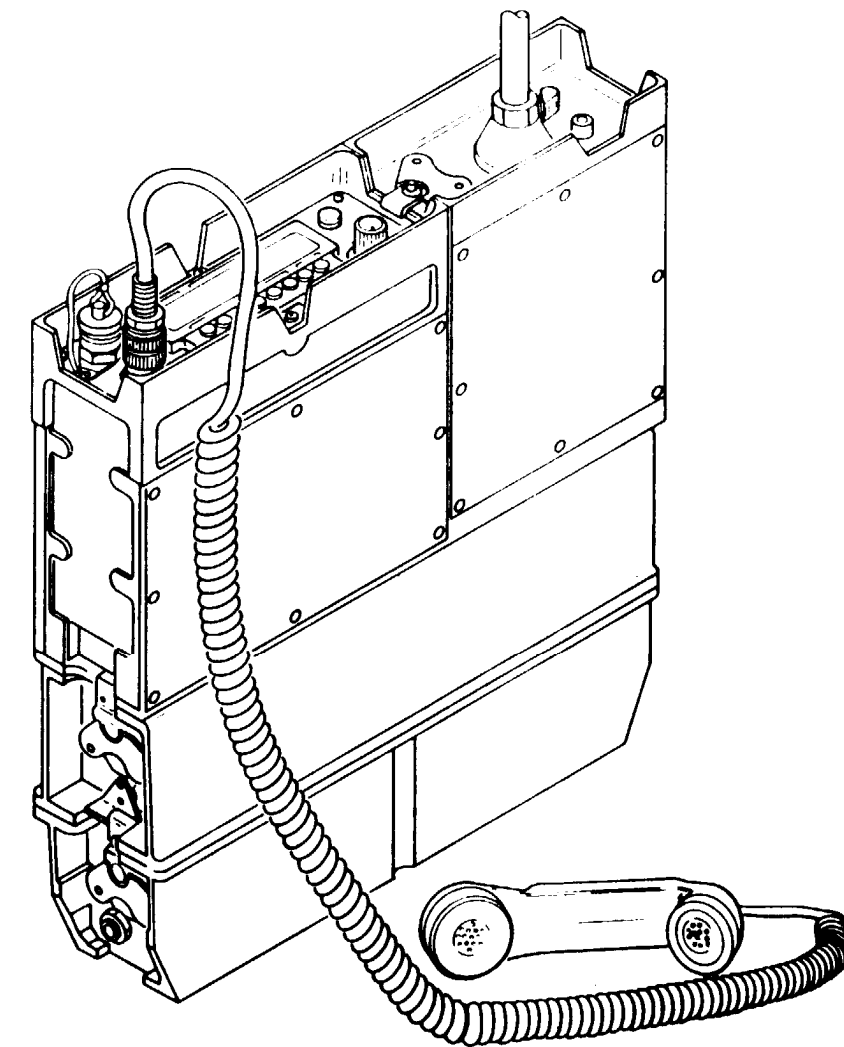

Figure 1-1. Radio Set AN/PRC-104

**PREPARATION FOR STORAGE OR SHIPMENT**

**STORAGE** — The radio set should be stored in the best available site that provides protection from the elements and unauthorized personnel. Covered sites are the best. If there is not enough covered space for all items, keep items covered that are most likely to be damaged by the weather. Items that cannot be covered should be stored on hard surfaces that drain well. Trucks, vans, and containers may be used if they give the best available protection. Be sure to comply with the fire plan for fire-fighting equipment and personnel.

Marine Corps personnel will refer to MCO P4450.7 for preparation of storage (Marine Corps Warehousing Manual).

**WARNING**

A lithium-sulfur dioxide (lithium) battery used with the radio set contains pressurized sulfur dioxide (SO<sub>2</sub>) gas. To prevent rupture, do not heat, short circuit, crush, puncture, mutilate, or disassemble lithium batteries; do not recharge or test lithium batteries for capacity; do not use a Halon type fire extinguisher on a lithium battery.

Do not use any lithium battery which shows the following signs of rupture: bulging, swelling, disfigurement, brown liquid in the plastic wrap, or a swollen plastic wrap. If the battery compartment becomes hot to the touch, or a hissing sound or the smell of SO<sub>2</sub> gas is present, immediately turn off the equipment. Move the equipment to a well-ventilated area or leave the area.

**WARNING**

In the event of a fire near a lithium battery, use a carbon dioxide (CO<sub>2</sub>) type extinguisher. Rapid cooling of lithium batteries is necessary to prevent venting and the potential exposure of lithium. In the event that lithium metal becomes involved in fire, the use of a graphite-based Class D fire extinguisher is recommended, such as Lith-X or MET-L-X.

**WARNING**

Do not store lithium batteries with other hazardous materials and keep away from open flame or heat.

**SHIPMENT**

**PREPARATION** — Preparation consists of disassembling the radio set in accordance with organizational maintenance removal procedures in Operator's and Organizational Maintenance Manual Radio Set AN/PRC-104B(V)1 , (V)4, TM 07748 B-12/1 , TM 11-5820-1046-12.

Section II EQUIPMENT DESCRIPTION AND DATA

	Page
Radio Set Description .....	1-3
Technical Characteristics .....	1-4
Equipment Supplied .....	1-5

Equipment Not Supplied .....	1-6
Support Equipment .....	1-6
List of Publications .....	1-7

**RADIO SET DESCRIPTION, fig 1-2**

**CHARACTERISTICS**

- 20-watt manpack hf transceiver
- Weighs about 20 pounds
- Uses advanced technology LSI circuitry in a highly reliable, space-saving, modular package
- Composed of three compact subsystems latched together: RT, amplifier/coupler, and battery pack

**CAPABILITIES AND FEATURES**

- RT contains five modules: electronic front panel (EFP), synthesizer, modulator/demodulator, harmonic filter, and power supply.
  - EFP provides operational control of the radio set and couples transmit/receive audio signals between the audio devices in use by the radio set operator.
  - Synthesizer generates the 5-MHz, 70- or 80-MHz, and 70- to 105-MHz LO signals.
  - Modulator/demodulator, in transmit operation, converts the voice signal (xmt audio) into two successive intermediate frequencies and then into the transmit radio frequency (xmt rf). In receive operation, the same circuits reverse the operation, extracting the rcv audio from the rf input signal.
  - Harmonic filter removes spurious received signals and suppresses transmitter harmonics using six bandpass filters.
  - Power supply converts the +28 V to 6.5 V and 12.5 V.
- Amplifier/coupler contains the power amplifier and antenna tuner modules.
  - Power amplifier amplifies xmt rf from the modulator/demodulator during transmit operation.
  - Antenna tuner routes the filtered xmt rf from the harmonic filter to the selected antenna. Antenna tuner automatically matches the antenna impedance to the radio set.
- Battery pack provides the radio set with the +28 V (nominal) dc power. Consists of two NICAD rechargeable or two lithium batteries.

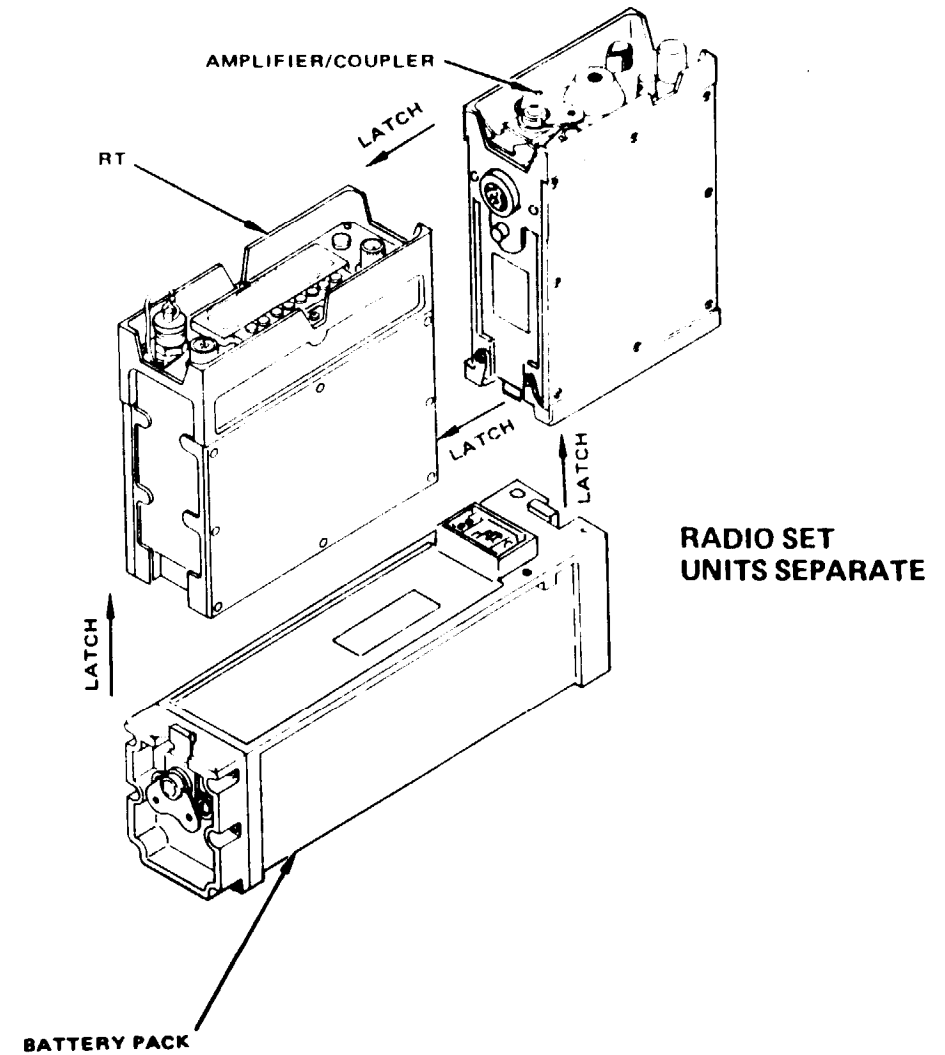

Figure 1-2. Radio Set Description

**TECHNICAL CHARACTERISTICS**

The technical characteristics for the radio set are listed in the following table.

Characteristic	Description
<b>RADIO SET AN/PRC-104 (Radio Set)</b>	
Antenna Tuning	Automatic to 1.5:1 VSWR (3 seconds tuning time, typical)
Audio Input Impedance and Level	0.6 mV rms
Dimensions	12.5" x 13.75" x 2.62" (31.75 cm x 34.93 cm x 6.66 cm) WxDx H
Frequency Accuracy	±1 ppm for -51°F (-46°C) to +160°F (+71°C) (±2 to 30 Hz of setting) from 2 to 30 MHz, respectively
Frequency Range	2.0000 to 29.9999 MHz in 0.0001-MHz (100 Hz) increments (280,000 possible frequency settings)
Operating Modes	<ul style="list-style-type: none"> <li>— Single Sideband (selectable USB or LSB)</li> <li>— Voice/cw (Morse or burst cw at 300 wpm)</li> <li>— Data (FSK or DPSK up to 2,400 bps), compatible with 75 baud military teletype</li> <li>— Receive only (inhibits transmit operation)</li> </ul>
Operating Temperature Range	-51°F (-46°C) to +160°F (+71°C)
Power Requirements	20.0 to 32.0 V dc with input at 3.5 amp (24 V dc) for transmit (typical); 200 ma for receive (typical)
RF Output Impedance	50 ohms, unbalanced. Output protected to infinite VSWR due to antenna short or open
RF Output Power	20 W (PEP), 0.25 W (PEP) exciter output
Weight	17.94 lb (8.15 kg) including lithium batteries (without accessories), or 20.59 lb (9.32 kg) including NICAD batteries (without accessories)

Characteristic	Description
<b>RECEIVER</b>	
Audio Distortion	5% at 5 mW, 350 to 3000 Hz
Audio Output	25 mW into 500 ohms (nominal)
Densitization (signal to degrade SINAD 3 db)	±2.5% to -29 dbm ±10% to -15 dbm; ±50% to +17 dbm
I.F. Rejection	60 db
Image Rejection	70 db
Selectivity SSB, CW, FSK	2.5 kHz bandwidth at -3 db 6.0 kHz bandwidth at -60 db
Sensitivity SSB, CW, FSK	0.7 μV for 10 db SINAD (-110 dbm voice, -70 dbm data)
<b>TRANSMITTER</b>	
All other Spurious	-45 to -60 db
Carrier Suppression	-42 db
Duty Cycle	1 minute keydown, 9 minute receive, 9:1 ratio
Harmonic Radiation	-50 db
Intermodulation Distortion (IMD)	-25 db (two equal tones at rated output power)
RF Output Power	0.3 to 1.0 W (PEP) for RT-1209A, 20 W (PEP or average) with AM-6874
Unwanted Sideband Suppression	-45 db
<b>BATTERY CASE</b>	
Battery Types	Two 28-volt lithium primary batteries BA-5590/U or two 24-volt NICAD rechargeable batteries BB-590/U
Case Dimensions	3.25" x 12.50" x 6.50" (8.26 x 31.75 x 16.51 cm) H x W x D

**EQUIPMENT SUPPLIED**

The radio set and accessory equipment that is supplied in the transit case are listed in the table below.

Nomenclature	Reference Designator	Common Name	Radio Set Configuration	
			VI (Marine Corps)	V4 (Army)
Adapter, Assembly UG-349A/U	...	dipole antenna adapter		X
Amplifier, Radio Frequency AM-6874 /PRC-1 04 -	A2	amplifier/coupler	X	X
Antenna Tuner	A2A2	antenna tuner	X	X
Housing, Radio Frequency Amplifier	...	amplifier/coupler housing	X	X
Power Amplifier	A2A1	power amplifier	X	X
Antenna AT-271 A/PRC	...	manpack whip antenna	X	X
Antenna Group AN/GRA-50	...	dipole antenna		X
Antenna, High Frequency, NVIS AS-2259( )/GR	...	NVIS antenna		X
Base, Antenna Spring Section	...	antenna base	X	X
Battery Case CY-7875/PRC-1 04	...	battery case	X	X
Cable Assembly, Bench Test	...	bench test cable	X	
Cable Assembly, Electrical Power CX-13032/PRC-1 04	...	battery charger cable		X
Cable Assembly, Electrical Power CX-1303/PRC- 104	...	battery extender cable	X	X
Cable Assembly, Radio Frequency CG-381 5/U	...	NVIS RF cable	X	X
Cargo Support Shelf MIL-F-43834	...	cargo shelf	X	X
Field Pack MIL-F-43833	...	field pack	X	X
Ground, Base, Antenna, NVIS	...	antenna ground base	X	X
Handset H-250/U	...	handset	X	X
Instruction Card	...	instruction card		X
Instruction Card	...	instruction card	X	
Key, Telegraph KY-872 /PRC-1 04	...	cw key	X	X
Pack Frame MIL-F-43835	...	pack frame	X	X
Receiver/Transmitter Assembly RT-1 209A	A1	RT	X	X
Cable Assembly, Electrical	...	electrical cable	X	X
Cable Assembly, Radio Frequency	...	RF cable	X	X
Cable Assembly, Radio Frequency	...	RF cable	X	X
Cover Assembly	...	cover	X	X
Electronic Front Panel	A1A4	EFP	X	X
Harmonic Filter	A1A2	harmonic filter	X	X
Housing, RT	...	RT housing	X	X
Modulator/Demodulator	A1A1	modulator/demodulator	X	X
Plate, identification	...	I.D. plate	X	X
Power Supply	A1A5	power supply	X	X
Synthesizer	A1A3	synthesizer	X	X
Webbing Strap MIL-F-43828	...	webbing strap	X	X

**EQUIPMENT NOT SUPPLIED**

The following table lists the equipment used with the radio set that is not supplied in the transit case.

Item	Common Name	Purpose
Battery, Nicad, rechargeable	NICAD battery	Battery for battery pack
Battery, Lithium, throwaway	Lithium battery	Battery for battery pack

**SUPPORT EQUIPMENT**

The test equipment required to perform maintenance of the radio set is listed below

**TEST EQUIPMENT**

**NOTES**

1. Equivalent test equipment may be used.
2. Use only test equipment that is properly calibrated. Failure to do so may provide erroneous or misleading performance or fault indications.
3. If adequate wattmeter is not available substitute vtvm terminated with dummy load,  $P = E^2/R$  where  $R = 50$  ohms.
4. \*Test equipment used by Marine Corps only.

Name	Equipment Characteristics	Quantity
Attenuator, Coaxial	Attenuation: 20 db Power Rating: 30 W min Resistance: 50 ohm	1
Attenuator, Step	Attenuation: 0 to 120 db in 10-db steps Frequency Range: dc to 1 GHz Power Rating: 0.5 W	1
•Audio Oscillator, AN/URM-127	Frequency Range: 0 to 600 kHz Output: 10 Vp-p max Sinewave Output	1
Bench Repair Center, PRC-350C		1
Dent Filler		1
Frequency Converter Test Bed AI AI AI		1
Frequency Converter Test Bed AI AI A2		1
Frequency Converter Test Bed AI AI A3		1
Detecting Element, 50 H		1
•Digital Multimeter (DVM, ohmmeter function) AN/USM-341	Measurement Range: 10 $\mu$ V to 300 V Resistance: 1 $\Omega$ to 30 M $\Omega$	1
•Distortion Analyzer, AN/URM-1 84A	Frequency Range: 10 Hz to 110 kHz Distortion Measurement: 0.01% to 1000/0 (full scale) -80 db to 0 db	1

Name	Equipment Characteristics	Quantity
Dummy Load, 8085		1
Extender Cable Set, AN/PRC-1 04		1
— Modulator Extender Cable		1
— Antenna Extender Cable		1
— Synthesizer Extender Cable		1
— Filter/Power Amplifier Extender Cable		1
— Coaxial Extender Cable		4
— Coaxial Extender Cable		2
— Audio Adapter		1
— Antenna Adapter		1
— Antenna Adapter		1
— 100-ohm Termination		1
— 130-ohm Termination		1
“ Frequency Counter AN/USM-459	Frequency Range: 5 Hz to 150 MHz Accuracy: 0.1 Hz	1
Maintenance Kit OA-9161 /GRC-213		1
Multimeter, AN/PSM-45		1
•Oscilloscope 0S-26 C(V)1 /U	Bandwidth: dc to 200 MHz Resolution: 2 mV to 50 V input voltage Range: 40 mV to 40 V Output: 26.5 V dc at 5 amp	1
Power Supply, PP-4763A/GRC		1
Radio Set, Test Bed AN/PRC-1 04		1
RF Signal Generator, SG-1 170/U	Frequency Range: 100 kHz to 1040 MHz Output Power: -140 dbm to +17 dbm	1
•RF Voltmeter, AN/USM-468		1
•Signal Generator, SG-1 171( )/U	Frequency Range: 100 kHz to 1040 MHz Output Power: -140 dbm to +17 dbm	1
•Spectrum Analyzer, Mainframe, IP-1216(T)	Frequency Range: 5 Hz to 150 MHz Bandwidth: 3 Hz to 30 kHz Video Bandwidth: 1 Hz to 30 kHz Measurement Range: -120 dbm to +20 dbm	1
— IF Section, PL-1 388/U		1
— RF Section, PL-1399/U		1
— Tracking Generator, SG-1 122/U		1
•Switch Attenuator	Attenuation: 0 to 120 db in 10-db steps Frequency Range: dc to 1 GHz Power Rating: .5 W	1
Test Set, Radio Frequency, AN/USM-298		1
VTVM AN/USM-1 16		1
Wattmeter, RF	Power Measurement: -65 db to +44 db Frequency Range: 100 kHz to 50 GHz	1
— Power Meter		1
— Thermo Couple Power Sensor		1
•50-ohm Load, Bird 8325		1



**SPECIAL TOOLS, MATERIALS, FABRICATED CABLES, AND FIXTURES**

The special tools, materials, fabricated test cables, and fixtures required for field maintenance of the radio set are listed in the table below.

Description	Part Number
Conformal Coating Electronic Tool Kit (TK-105/G) ‘ Printed Circuit Maintenance Kit (MK-984/A)	MIL-I-46048, Type UR

BLANK  
INTENTIONALLY

CHAPTER 2  
THEORY OF OPERATION

Section I. PRINCIPLES OF OPERATION

	Page
Transmit Operation .....	2-2
Receive Operation .....	2-4

**TRANSMIT OPERATION (1 of 2), fig 2-1**

**A** For ease of explanation, assume the voice signal (xmt audio) from the handset is 1 kHz. The xmt audio signal from the handset is routed through the audio filter, which suppresses spurious rf noise signals picked up at the handset.

**B C** The xmt audio signal is then mixed in the third frequency converter with the 5 MHz local oscillator (LO) signal from the synthesizer. The mixer produces two signals: (1) 5 MHz - xmt audio\*, and (2) 5 MHz + xmt audio. The 5 MHz crystal filter passes the 5 MHz - xmt audio (4.999 MHz) and suppresses the 5 MHz + xmt audio signal.

**B C** The output of the 5-MHz crystal filter is then mixed in the second frequency converter with 70 MHz if upper sideband (USB) is selected on the control panel, or with 80 MHz if lower sideband (LSB) is selected. The mixer also produces the following signals:

1. Upper sideband selected
  - a. 70 MHz + 5 MHz if. (74.999 MHz)\*
  - b. 70 MHz -5 MHz if. (64.999 MHz)
2. Lower sideband selected
  - a. 80 MHz -5 MHz if. (75.001 MHz)\*
  - b. 80 MHz -5 MHz if. (84.999 MHz)

The 75-MHz crystal filter passes 74.999 MHz (USB) or 75.001 MHz (LSB).

**B** The automatic level control (ALC) circuits maintain the signal level required to produce the 20-watt output power for the radio set. The ALC circuits receive feedback from the power amplifier or antenna tuner.

ALC feedback from the antenna tuner is used only during tune-up.

**B** The output of the 75-MHz crystal filter is mixed in the first frequency converter with 77-105 MHz LO from the synthesizer. The generation of the 77-105 MHz LO signal is controlled by the frequency selector switch settings on the control panel. For example, if the frequency selector is set to 2 MHz, 77 MHz is generated and mixed. If 3 MHz is selected, 78 MHz is generated; if 29.999 MHz is selected, 104.999 MHz is generated. If 2 MHz is selected, the mixer produces the following:

1. Upper sideband selected
  - a. 77 MHz + 74.999 MHz (151.999 MHz)
  - b. 77 MHz -74.999 MHz (2.001 MHz)\*
2. Lower sideband selected
  - a. 77 MHz + 75.001 MHz (152.001 MHz)
  - b. 77 MHz -75.001 MHz (1.999 MHz)\*

**D** The 0.3 to 1 watt (PEP) amplifier in the first frequency converter rejects the 151.999 MHz or 152.001 MHz. The 2.001-MHz signal (USB), or 1.999-MHz signal (LSB), is amplified up to 0.25 watt, then amplified again to 20 watts by the 20-watt amplifier.

**E F** The 1.999- or 2.001-MHz 20-watt signal (xmt rf) is routed through the harmonic filter for further filtering and through the L-C network of the antenna.

\*Indicates the desired signal.

**TRANSMIT OPERATION (2 of 2)**

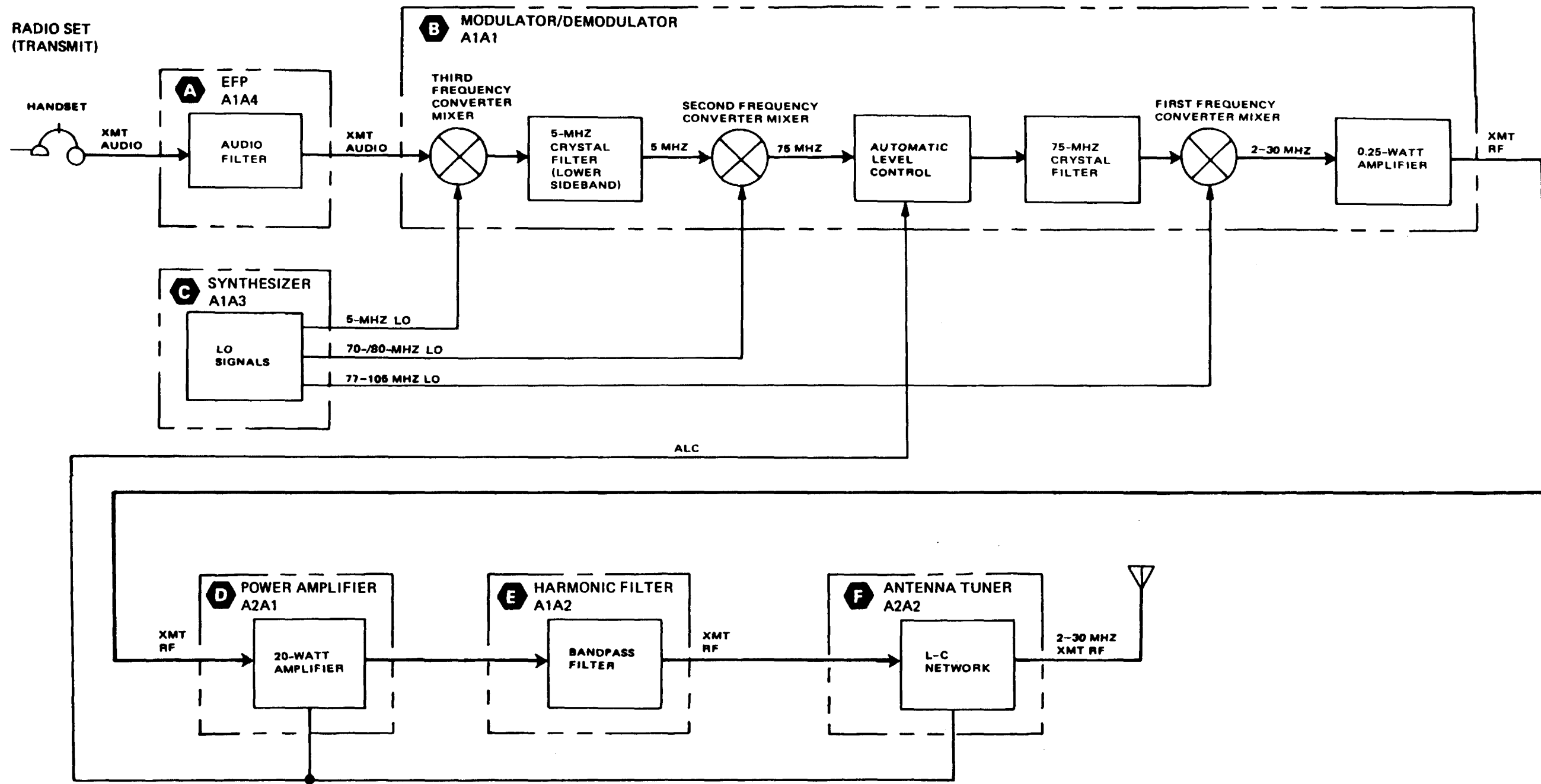

STA-J-40104-2-1-1

Figure 2-1. Transmit Operation

RECEIVE OPERATION

**A B** Assume that the receive rf (rev rf) signal is 2 MHz with a 1 -kHz voice signal. The 2-MHz rcv rf signal is routed from the antenna, through the L-C network and harmonic filter to the first frequency converter mixer. The 2 MHz (2.001 MHz USB, 1.999 MHz LSB) is mixed with 77 MHz LO to produce 74.999 MHz (USB) or 75.001 MHz (LSB).

**C D E** The output of the mixer is routed through the 75-MHz crystal filter and the 75-MHz amplifier, and mixed in the second frequency converter with 70 MHz (USB) or 80 MHz (LSB). The resulting mixer outputs, 4.999 MHz (USB) or 5.001 MHz (LSB), is routed through the 5-MHz crystal filter, through the automatic gain control (AGC) circuits, and mixed with 5-MHz LO. In the third frequency converter, the mixer produces 1-kHz (rev) audio, which is routed through the audio filter to the earphones.

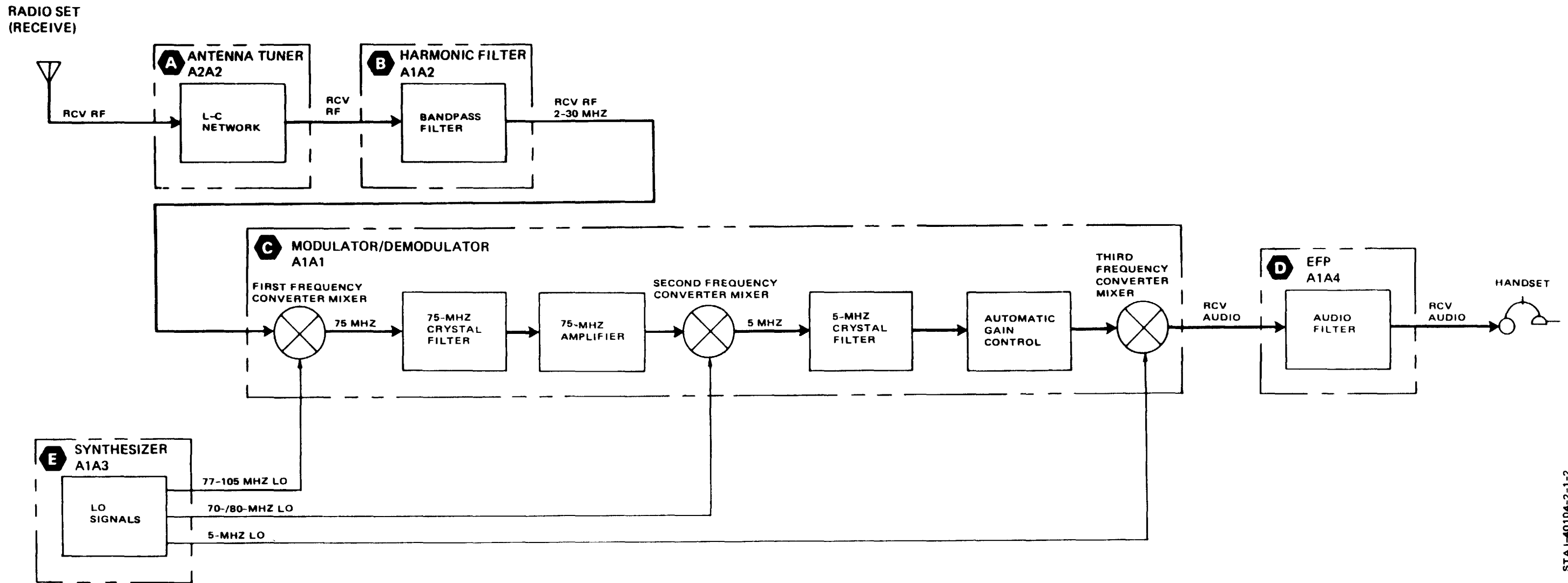

Figure 2-2. Receive Operation

Section II RADIO SET GENERAL DESCRIPTION

	Page
General .....	2-5
RT, Amplifier/Coupler and Battery Pack General Description .....	2-6

**GENERAL**

The AN/PRC-104 is a short term anti jam (STAJ) radio set consisting of three major assemblies:

1. Receiver/Transmitter (RT) (AI)
2. Amplifier/Coupler (A2)
3. Battery Pack

The RT contains five modules: (1) electronic front panel, (2) synthesizer, (3) modulator/demodulator, (4) harmonic filter, and (5) power supply. The amplifier/coupler contains the power amplifier and antenna tuner modules. The battery pack provides the radio set with the +28 V (nominal) dc power.

**RT, AMPLIFIER/COUPLER, AND BATTERY PACK GENERAL DESCRIPTION (1 of 2), fig 2-3**

**RT GENERAL DESCRIPTION**

**A** **ELECTRONIC FRONT PANEL** — The electronic front panel (EFP) provides operational control of the radio set and couples transmit/receive audio signals between the audio devices in use by the operator and the radio set. The EFP contains the FREQUENCY KHz (frequency select) pushbutton switches, MODE select pushbutton switches, CONT connector (not used), VOLUME OFF/MAX control LIGHT pushbutton switch, and AUDIO connector. A controller may be used with the radio set for electronic counter countermeasure (ECCM) operation. Although the controller and ECCM operation are not used here, they are discussed throughout the text for better understanding of the radio set.

**Frequency Selection** — The FREQUENCY KHz pushbutton switches select the operating frequency of the radio set (2,000.0 thru 29,999.9 kHz). The frequency pushbutton switches send frequency select signals (logic data) to the synthesizer for use in determining the frequency of the 77-105MHz LO signal. The frequency select signals are also used by the antenna tuner during impedance matching. The filter select signal from the frequency select switches is used by the harmonic filter to select the bandpass filter corresponding to the selected frequency.

**Mode Selection** — The left-hand MODE switch selects either voice transmit (VTR), voice receive (V RCV), data transmit (DTR), or data receive (D RCV). The mode select signals are used by the modulator/demodulator to control the processing of the transmit/receive radio frequency (xmt rcv rf). In the voice mode, the microphone input impedance is 150 ohms and the VOLUME OFF/MAX control adjusts the level of rcv audio. In the data mode, the input impedance is changed to 600 ohms, which is compatible with standard data systems. The VOLUME OFF/MAX control is also disabled so that a constant receive level is maintained. In addition, the receiver AGC release time constant is shortened to reduce the receive response time to Incoming data.

**Sideband Selection** — The right-hand MODE switch selects either upper sideband (USB) or lower sideband (LSB) of the radio frequency. The sideband select signals are sent to the synthesizer. The synthesizer sends either 70 MHz LO to the modulator/demodulator if USB is selected or 80-MHz LO if LSB is selected.

**Volume Control** — The VOLUME OFF/MAX control used to control the rcv audio signal level from the modulator/demodulator.

**B** **SYNTHESIZER** — The synthesizer generates the 5-MHz LO, 70-(USB) or 80-(LSB) MHz LO, and 77-105 MHz LO signals. The exact frequency of 77-105 MHz LO is 75 MHz plus the control panel frequency. The LO signals are used by the modulator/demodulator in the processing of transmit) receive signals. A 5-MHz clock signal is generated by the synthesizer for the control interface assembly. The synthesizer also generates a 1-kHz tone that is used by the modulator/demodulator to develop a cw key tone.

**C** **MODULATOR/DEMODULATOR** — In transmit operation, the modulator/demodulator converts xmt audio into two successive intermediate frequencies and then into xmt rf. During receive operation, the same circuits reverse the operation, extracting rcv audio from the rf input signal.

**D** **HARMONIC FILTER** — The harmonic filter removes spurious received signals and suppresses transmitter harmonics using six bandpass filters. The filter select signals from the control panel determine the choice of filter. In transmit mode, xmt rf is routed from the power amplifier through the harmonic filter and to the antenna tuner. In receive mode, the rf flow is reversed.

**E** **POWER SUPPLY** — The power supply converts the +28 V to 6.5 V and 12.5 V.

**AMPLIFIER/COUPLER GENERAL DESCRIPTION**

**E** **POWER AMPLIFIER** — The xmt rf signal from the modulator/demodulator is amplified by the power amplifier during transmit operation to provide 20 watts of power. The power amplifier is bypassed during receive operation.

**G** **H** **ANTENNA TUNER AND ANT SEL** — In transmit operation, filtered xmt rf from the harmonic filter is routed through the antenna tuner to the selected antenna. The antenna tuner automatically matches the antenna impedance to the radio set. In receive operation, the rf flow is reversed. The antenna tuner is bypassed if the antenna select switch (ANT SEL) is in the 50Ω position.

**BATTERY PACK GENERAL DESCRIPTION**

**I** **BATTERY PACK** — The battery pack may contain 24 V nickel-cadmium or 28 V lithium cells.



**T, AMPLIFIER/COUPLER, AND BATTERY PACK GENERAL DESCRIPTION (2 of 2)**

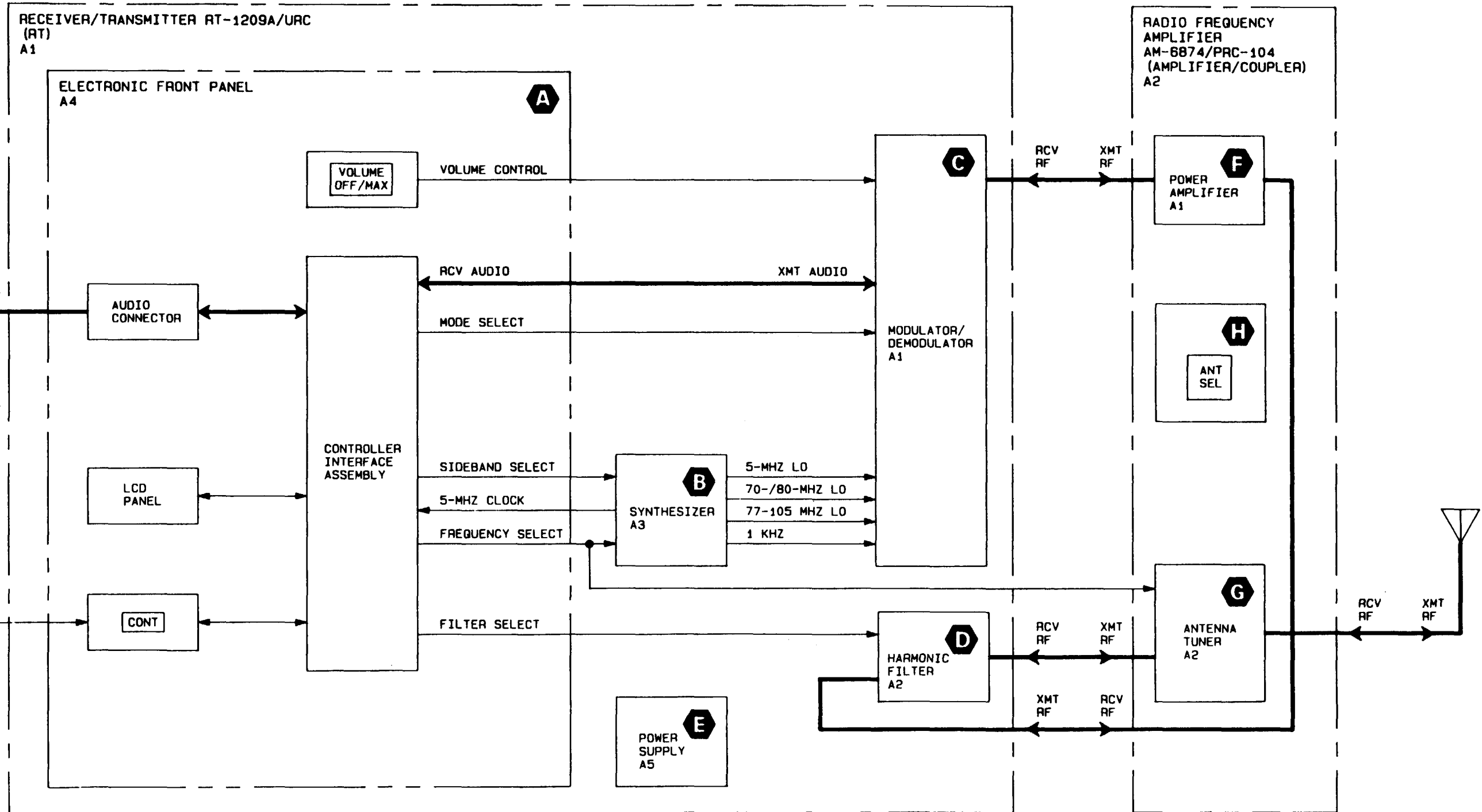
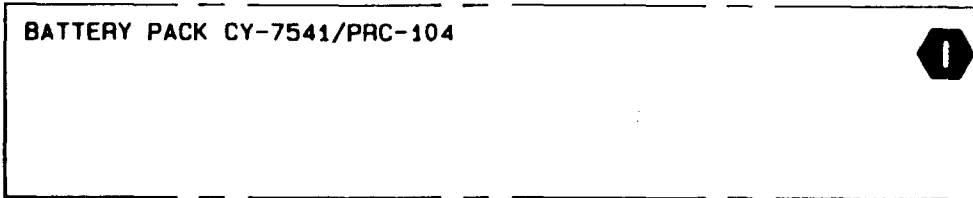

2-3. RT, Amplifier/Coupler, and Battery Pack General Description

BLANK  
INTENTIONALLY

**Section III. DETAILED FUNCTIONAL DESCRIPTION**

	Page		Page
General .....	2-9	77-105 MHz Voltage-Controlled Oscillator (VCO) .....	2-30
Amplifier/Coupler Detailed Functional Description .....	2-10	Ramp Generator .....	2-31
Power Amplifier .....	2-10	5-MHz Converter .....	2-31
Antenna Tuner .....	2-14	Modulator/Demodulator .....	2-32
RT Detailed Functional Description .....	2-16	Audio Control Hybrid .....	2-34
Electronic Front Panel .....	2-16	Automatic Level Control .....	2-40
Control Interface Assembly .....	2-18	Frequency Converters .....	2-42
Audio Filter Assembly .....	2-25	Harmonic Filter .....	2-48
Synthesizer .....	2-26	Power Supply .....	2-50
70/80 MHz Voltage-Controlled Oscillator (VCO) .....	2-30		

**GENERAL**

This section contains a detailed functional description of the radio set. Included in this description is the amplifier/coupler, RT, and power supply.

**AMPLIFIER/COUPLER DETAILED FUNCTIONAL DESCRIPTION**

The amplifier/coupler detailed functional description contains the theory of operation for the power amplifier and antenna tuner modules.

**POWER AMPLIFIER (1 of 4), fig 2-4, sh 1**

**GENERAL** — The power amplifier boosts the 0.25-watt (nominal) output from the modulator/demodulator to provide 20 watts (nominal) rf power at the antenna. The module also contains temperature compensation and overpower protection circuits which prevent damage in the event of a malfunction. In addition, the regulated power supply for the antenna tuner relays is in this module.

**A** **TRANSMIT/RECEIVE OPERATION** — In transmit operation, relays K1 and K2 are energized by the keyline signal from the modulator/demodulator. These relays switch the amplifiers into the rf path in the transmit mode. They also cause +28 V battery to be switched into the system as +28 V battery xmt. When +28 V battery xmt is present, switch Q13 conducts and applies +6.5 V xmt to various circuits. In receive operation, the relays are deenergized and the rf bypasses the amplifiers.

**B** **E** **RF PREAMPLIFICATION** — The driver stage (T1, Q3, Q6, T2) amplifies the 0.3 to 1 watt (PEP) xmt rf to about 2 watts using a push-pull amplifier configuration. The push-pull amplifier configuration consists of basically two transistors (Q3, Q6) with input and output transformers (T1, T2). This stage is powered by +28 V battery xmt. The amplification of this stage can be retarded by the PA disable switches (Q4, Q5). These two switches are normally enabled (conducting) by the overshoot control (AR4-2, AR3-2) when PA disable is low. If the enabling voltage is reduced, Q4 and Q5 decrease conduction and reduce the rf amplification.

**C** **RF OUTPUT AMPLIFICATION** — Next, the rf is amplified to about 20 watts by the output stage (T3, Q10, Q11, T4, T5). This amplification is also done using a push-pull configuration with input transformer T3 and output transformers T4, T5. This stage is powered by +31 V xmt from the DC-DC converter.

**C** **TEMPERATURE COMPENSATION** — Both the driver stage (T1, Q3, Q6, T2) and the output stage (T3, Q10, Q11, T4, T5) use temperature-compensating bias circuits: (1) Q1, Q2, and (2) Q7, Q8, and Q9, respectively. These circuits provide temperature compensation by reducing the tendency for the gain of the push-pull amplifiers to increase as the temperature rises. Both bias circuits use +6 V xmt for input voltage.

**D** **OVERPOWER DETECTOR AR4-1** - The overpower detector receives xmt rf input via isolation transformer T6. Any large excess in the power reflecting back at the power amplifier causes a voltage to be applied to the overshoot control and ALC circuits via overpower.

**E** **OVERSHOOT CONTROL AR4-2, AR3-2** — The overshoot control acts on information regarding antenna match in the form of buffered VFWD and VREFL inputs from the harmonic filter, or overpower input from the overpower detector AR4-1. VFWD is a measure of the energy going to the antenna and VREFL is a measure of the energy that is reflecting back at the harmonic filter. VFWD and VREFL are summed, amplified, and compared against a reference value. If the power reflection condition is momentarily high, the overpower detector ceases to apply an enabling voltage, via PA disable, to the PA disable switch; the rf amplification is reduced; and power is reduced to a safe level.

**F** **ALC AR3-1** — The ALC amplifier processes the same information as the overshoot control (buffered VFWD and VREFL), but the reference voltage is lower. In addition, the ALC uses the ALC signal to affect xmt rf at the modulator/demodulator module and the reaction time is slower. As a result of the longer reaction time (typically 5 milliseconds), the overshoot control acts to dampen the initial peak of the xmt rf signal until the ALC reduces xmt rf at the modulator/demodulator.

**POWER AMPLIFIER (2 of 4)**

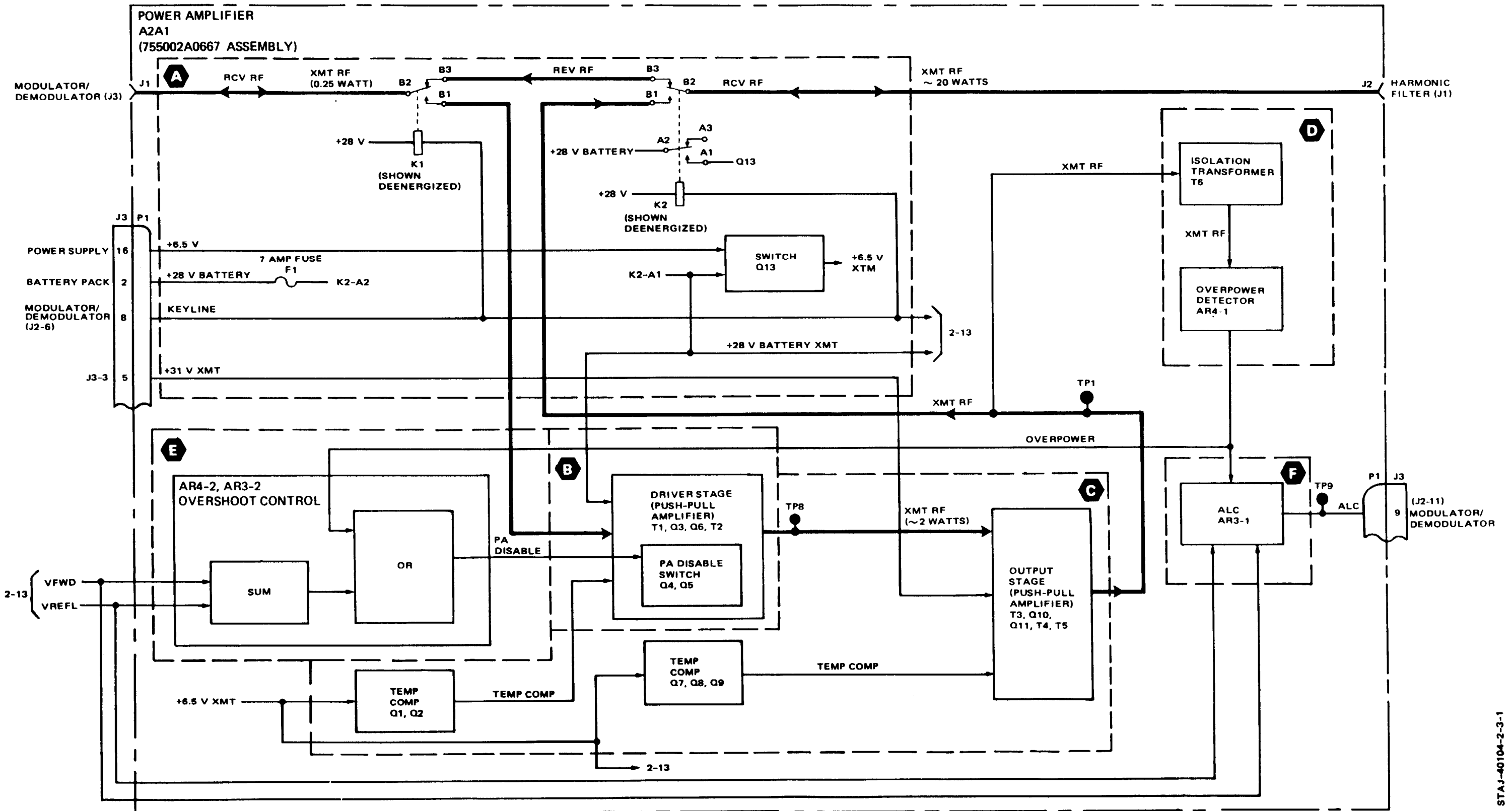

Figure 2-49 Power Amplifier (sheet 1)

STA J-40104-2-3-1

**POWER AMPLIFIER (3 of 4), fig 2-4, sh 2**

**G** SIDETONE ENABLE AR2-1, Q15 — This circuit determines whether the power output is adequate for transmit communication (about 6 watts). If so, audio feedback is provided to the operator. Again, the buffered VFWD and VREFL voltages are compared against reference values. The difference is that the output of AR2-1 passes through switch Q15. Q15 is enabled by both the keyline signal (grid) from the modulator/demodulator and an adequate power level. The activated state (Q 15 conducting) of sidetone enable is +1.4 V or less. The tune in progress signal provides sidetone enable by passing ground through diode CR24 during the automatic tuning process. When tune in progress is present, the operator hears a 1-kHz tone.

**H** TUNE CHECK ENABLE AR2-2 Q16 — If, while transmitting, the antenna should become detuned, tune check enable is applied to the antenna tuner. Buffered VFWD and VREFL are sampled and compared against a reference value at AR2-2. If the vswr is greater than 1.6:1, tune check enable causes retuning the next time PTT is pressed. Q16 ensures the radio is in transmit mode and keyline is grounded. In the active state, this line is about +6 V. Tune in progress prevents a false tune check enable from being generated during the tuning process.

**I** TUNER DC SOURCE TR1, Q1, Q2, Q3, Q11 — This circuit provides a regulated power supply (+16 V regulated) for the relays in the antenna tuner module. The circuit compensates for changes in temperature

and battery voltage; it is activated by grounds from tune in progress or tune start lines, which turn on switch Q11. Q11 is powered by +28 V on. As temperature increases, the voltage needed to drive the antenna tuner relays increases. Conversely, if the temperature decreases, the relay voltage decreases. The temperature-dependent voltage range is from approximately +12 V to +18 V. The mechanism of temperature regulation is thermistor TR1; as the temperature increases, its resistance decreases. A Zener diode, VR1, is connected so that a constant +18 V is applied to the thermistor. Transistors Q1, Q2, Q3 buffer the thermistor output to provide a low impedance dc source.

**J** DC-DC CONVERTER — This network converts +28 V battery xmt to +31 V xmt which is used in the output stage (T3, Q10, Q11, T4, T5). It works in the following way:

1. Switch Q10 closes. Current flows through coil L2, storing energy.
2. When Q10 opens, the energy stored in L2 is transferred to C32 via diode CR5,
3. The current flowing in C32 charges it to +31 V.
4. The energy stored in L2 (which determines the charge of C32) is proportional to the on and off time of switch Q10. Oscillator U1, Q4 sets the frequency to 50 kHz. Differential amplifier Q5, Q6 determines the on to off ratio (duty cycle) via feedback applied through Q9. Driver Q7, Q8 provides the base current to drive switch Q10. The +6.5 V xmt signal powers U1, Q4, Q5, Q6, Q7, Q8.

**POWER AMPLIFIER (4 of 4)**

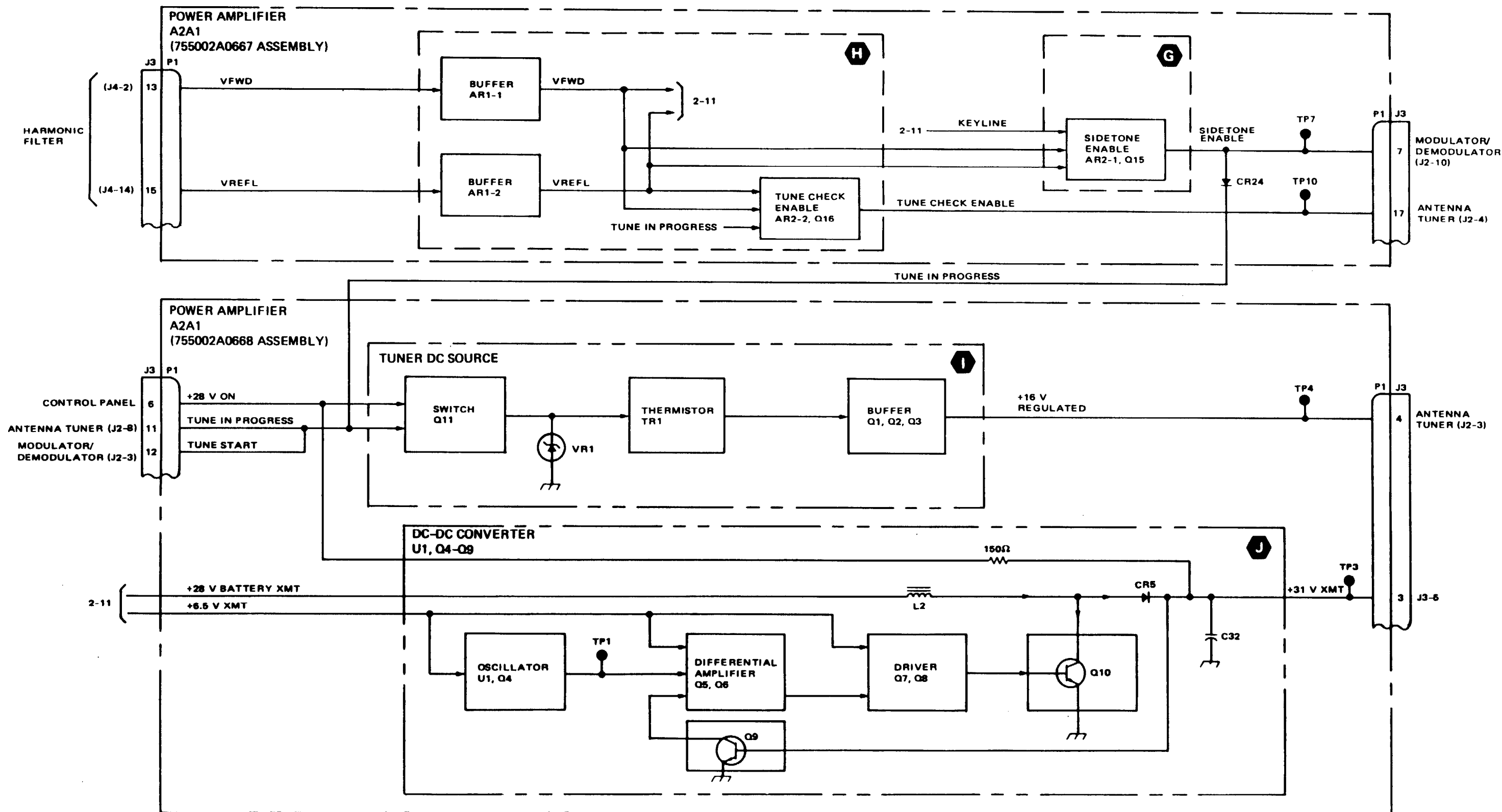

Figure 2-5. Power Amplifier (Sheet 2)

**ANTENNA TUNER (1 of 2), fig 2-5**

**GENERAL** — The antenna tuner automatically matches impedances between the radio set (50 ohms resistive) and the selected antenna (reactive/resistive). The module systematically switches inductors and capacitors into the L-C coupling network KL1-KL11, KC1-KC8, until the resulting impedance matches the impedance of the radio set.

**A** **TUNE START** — A tune start signal is generated whenever any of the following occur:

1. The radio is turned on.
2. The MODE switch is changed from V RCV or D RCV to VTR or DTR.
3. The frequency is changed by 1 kHz or more.

The tune start signal turns the +16 V relay supply (located at the power amplifier module) on momentarily, and causes removal of the impedance-matching elements from the rf pathway.

**A** **TUNE-CHECK ENABLE** — A tune-check enable signal is sent from the PA module to the antenna tuner hybrid, if a high vswr condition (vswr is the detection of swr) occurs during a normal transmission. The antenna tuner performs a tune check the next time keyline goes low. Keyline goes low when the push-to-talk (PIT) or continuous wave (CW) key is pressed.

**B** **TUNE CHECK** — Without disturbing the L-C values set into the tuning network, the antenna tuner hybrid activates RF transfer relay K9 with a tune in progress signal and measures the antenna tuner vswr. If the vswr is less than 1.6:1, tune in progress is removed, and RF transfer relay K9 deactivates and normal operation is resumed. If the vswr is greater than 1.6:1, the impedance-matching elements are removed from the rf pathway when the keyline goes low and hybrid logic control circuits maintain tune in progress signal to transfer relay K9. At this time, the module begins the tuning cycle.

**B** **ELEMENT SWITCHING** — Each inductive and capacitive element (L1-L11 and C1-C8) is switched into and out of the rf pathway by a relay (K1-K11 and K1-K8). The elements and relays are grouped together as KL1-KL11 and KC1-KC8. To switch an inductive element out of the rf pathway, the following must happen:

1. Antenna tuner hybrid AI pulses the set driver transistor with +0.8 V L-switch and C-switch.
2. The output of the set driver transistor changes from +16 V to ground.
3. The relay closes and short-circuits the inductive element (a coil) connected in parallel.

To switch an inductive element into the rf pathway, the reset driver transistor must be pulsed (L-switch and C-switch). The capacitive element (KC1-KC8) is connected in series with the relay via rcv rf and xmt rf. When the reset driver transistor is pulsed, the relay opens and switches the element out of the rf pathway. When the set driver transistor is pulsed, the relay closes and switches the element into the rf pathway.

**TUNING CYCLE** — The tuning cycle consists of the following:

1. **B** **C** When the keyline is grounded after a tune start or tune check enable has occurred, a tune in progress signal (active state is +0.7 V or less) is routed to the power amplifier and the transfer relay. This causes +16 V regulated to be applied to the relays KL1-KL11 and KC1-KC8, and the rf is routed through the energized contacts of transfer relay to the rf sensor bridge (R6-25, T2). The rf sensor bridge outputs Z (impedance), vswr, and ALC detect analog voltages.
2. **D** Antenna tuner hybrid AI places inductors KL1-KL11 in a binary count in the rf path by opening the associated relay. The antenna tuner hybrid samples the analog Z voltage and compares it to a reference voltage at a comparator.

3. **B** The inductance is incrementally added in a binary count. The inductance of KL2 is twice KL1; KL3 is twice KL2; KL4 is twice KL3, etc. (For example, on the fifth binary count — binary number 101, KL3 is in, KL2 is out, KL1 is in.) The L-C clock determines the count timebase.
4. **C** The count continues until the Z drops to indicate 100 ohms or less. At that time, the Z comparator digital output changes state and signals the control logic.
5. **B** **D** The control logic places capacitors KC1-KC8 between the rf path and ground in a binary count. The hybrid samples the vswr voltage and compares it to a reference at a comparator.
6. **B** **D** Capacitance is incrementally added until the vswr reaches 1.5:1. The comparator changes state and signals the control logic via digital. If the 1.5:1 vswr is not reached when all the capacitors are added, they are reset. Another inductor is added and the capacitor count begins again.
7. **B** When the vswr is 1.5:1, satisfactory impedance match has been achieved. The control logic discontinues the ground on the tune in progress line. The transfer relay is deenergized and the rf sensor bridge (R6-25, T2) ceases to sample the rf. The supply voltage to relays KL1-KL11 and KC1-KC8 is removed. The relays are held in place by magnetic latching.

In routine operation (after the tuning cycle), xmt rf is not sampled by the rf sensor bridge. The +16 V regulated supply from the power amplifier is off.

**D** **FREQUENCY SELECT LOGIC** — The frequency select logic signals from the control panel are applied to the control logic in the antenna tuner hybrid. The control logic selects which inductors and capacitors will be used at a particular frequency band. For example, at 2000 kHz, inductors KL1, KL2, and KL3 are bypassed in the binary count. KL4 becomes the least significant bit.

**D** **E** **TUNE FAULT LOGIC** — The average tuning time is approximately 3 seconds, but may run as long as 12 seconds. If the tuning has not taken place within 12 seconds, antenna tuner hybrid AI outputs an open on the no-tune line to tune fault logic U1, Q23. This causes the tune fault signal to become +6 V and the modulator/demodulator to generate a beeping signal to the user. If an illegal frequency has been selected (under 2 MHz), the frequency select logic inputs from the control panel will all be at ground, and the tune fault line again becomes +6 V.

**B** **ALC** — The ALC voltage (ALC detect) from the rf sensor bridge is compared with a reference voltage at a differential hybrid differential amplifier. The output ALC is routed to the modulator/demodulator. Note that this is used during tune-up only.

**F** **RECEIVE OPERATION** — During receive operation, the rf travels through the L-C coupling network to the modulator/demodulator. No tuning takes place while receiving. However, if a tune start is initiated, all capacitors and inductors are removed from the rf pathway. To initiate a tune-up, the PTT or cw key must be pressed.

**G** **ANTENNA SELECT SWITCH S1** — Antenna select switch S1 has three positions:

1. 50Ω
2. BNC antenna
3. WHIP antenna

In the 50Ω position, xmt rf and rcv rf bypasses the antenna tuner module, and the rf goes in and out of the BNC connector. In the BNC and WHIP positions, the rf is routed through the tuner to the BNC connector or whip socket, depending on which has been selected.



**ANTENNA TUNER (2 of 2)**

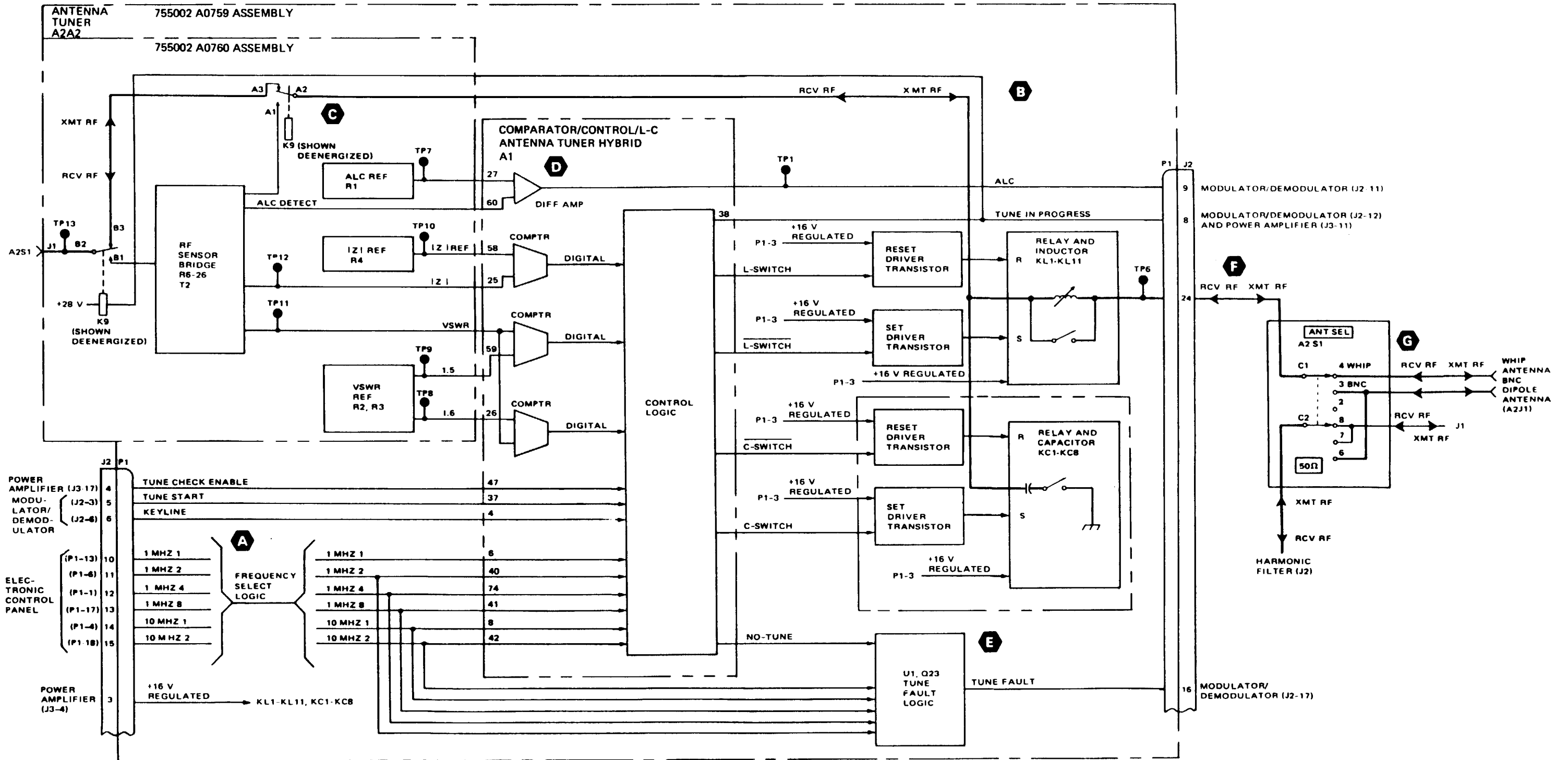

Figure 2-5. Antenna Tuner

**RT DETAILED FUNCTIONAL DESCRIPTION**

The RT detailed functional description contains theory of operation for the following RT functional sections:

- Electronic Front Panel
- Synthesizer
- Modulator/Demodulator
- Audio Control Hybrid
- Automatic Level Control
- Frequency Converters
- Harmonic Filter

**ELECTRONIC FRONT PANEL**

**GENERAL** — The electronic front panel (EFP) provides the means for the operator to control receiver/transmitter operations. The EFP consists of the front panel, control interface (CI), and audio filter assemblies.

**FRONT PANEL ASSEMBLY (1 of 2), fig 2-6**

The front panel assembly consists of the liquid crystal display (LCD) panel and display panel assembly.

**A** **LIQUID CRYSTAL DISPLAY (LCD) PANEL** — The LCD panel provides a visual display of the operating frequency and modes of operation. The LCD panel consists of 6 alphanumeric characters and 20 fixed-label elements. The alphanumeric characters display frequency information and the fixed-label elements display the RT operating mode.

The LCD panel is enabled by a display enable (-DISEN) signal received from the gate array. When one of the FREQUENCY KHz or MODE pushbuttons is pressed, MOSFET switch in the analog subassembly of the EFP applies 28 V heater (28 V HTR) to the LCD panel. When the thermistor in the LCD detects a temperature that requires heat to be applied to the LCDS for proper operation, the thermistor applies a ground to one side of the heater. With 28 V HTR applied to one side of the heater element and a ground applied to the other side, current flows through the heater element and heat is applied to the LCDS. Similarly, when the LIGHT pushbutton is pressed, ground is applied to the MOSFET switch, and activates 28 V LIGHT to the LCD panel to turn on the LCD panel backlight.

The signal LCD DATAIN is serial data sent by the gate array to display the correct segment on the LCD panel. LCD DATAIN is clocked by display clock (-DISCLK). A 76 Hz clock is also needed as a refresh clock for the LCDS.

**DISPLAY PANEL ASSEMBLY** — The display panel assembly provides the mechanical chassis used for mounting the LCD panel and contains the following controls:

1. FREQUENCY KHz pushbutton switches (six)
2. MODE select pushbutton switches (two)
3. LIGHT pushbutton switch
4. VOLUME OFF/MAX control

**B** **FREQUENCY KHz AND MODE PUSHBUTTONS** — The FREQUENCY KHz and MODE pushbuttons use a matrix switch system to send information to the EFP as to which operating frequency and mode have been selected by the radio operator. Data bits XI thru X4 are sent to the front panel assembly by the gate array of the digital subassembly of the EFP. The custom hybrid of the digital subassembly sends information to the gate array via data bits DO thru D7 to continually cycle through XI thru X4. When one of the pushbuttons is pressed, the corresponding matrix switch is closed. Information as to which button was pressed is sent to the gate via Y1 thru Y3. The following table illustrates how the switch matrix works.

Intersection	Function	Pushbutton Pressed
x1, Y1	F1	10 MHz
X2, Y1	F2	1 MHz
X3, Y1	F3	100 KHz
X1, Y3	F4	10 KHz
X2, Y3	F5	1 KHz
X3, Y3	F6	100 Hz
X4, Y1	M1	LEFT MODE
X4, Y2	M2	RIGHT MODE

**C** **LIGHT PUSHBUTTON** — When the LIGHT pushbutton switch is pressed, ground light switch return (LT SW RTN) is applied to the MOSFET switches of the EFP analog subassembly via light control (LGHT). This ground turns on the MOSFET switches and the front panel backlight turns on. The backlight remains on during the length of time the button is pressed. When the LIGHT button is released, the backlight goes off.

**VOLUME OFF/MAX CONTROL** — The VOLUME OFF/MAX control is a conventional on/off switch and potentiometer. The switch, when closed, applies ground volume switch return (VOL SW RTN) to the MOSFET switches of the EFP analog subassembly via volume switch (VOL SW). The MOSFET switches apply +28 V to various EFP circuits. In receive operations in ECCM mode, baseband preamble audio from the audio control hybrid is tapped off the TO VOLCTRL signal as FROM VOLCTRL. VOLCTRL RTN is the return ground signal.

FRONT PANEL ASSEMBLY (2 of 2)

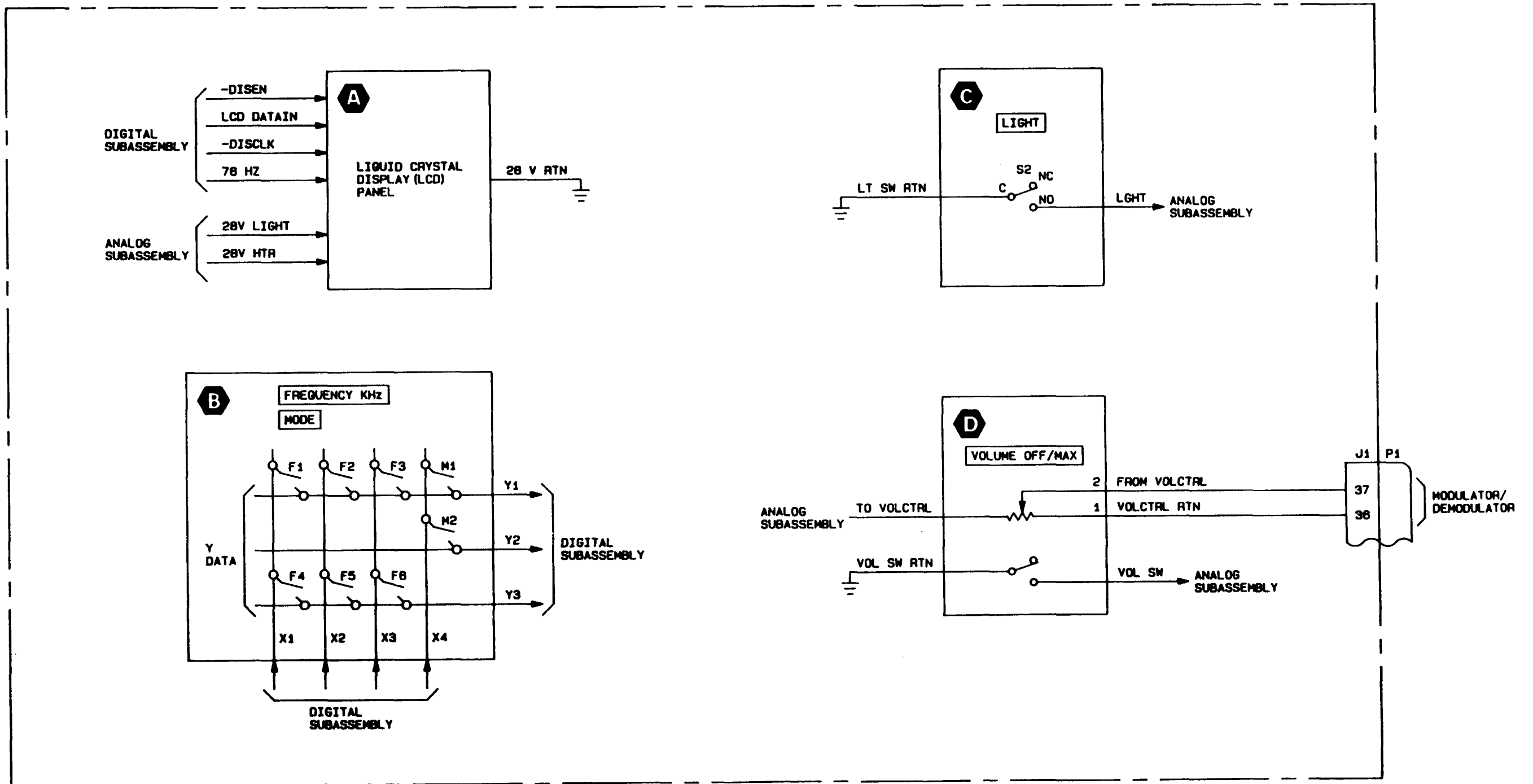

Figure 2-6. Front Panel Assembly

**CONTROL INTERFACE ASSEMBLY (1 of 7), fig 2-7, sh 1**

The control interface (CI) assembly is the control center of the EFP. It provides real-time control of both internal and external interfaces of the radio set. The CI assembly performs self-testing of the LCD panel display and memory section. Tests are initiated during the detection of a reset condition or power-up condition or by commands from the controller. The LCD tests consist of verification of all 123 LCD segments/indicators. Testing of the memory consists of checksums of the following:

1. Microprocessor registers
2. EEPROM
3. EPROM

Self-test failures are indicated on the LCD panel using the following formats:

1. "REG"; NO GO — identifies microprocessor register failure
2. "PROM"; NO GO — identifies EPROM failure
3. "ROM"; NO GO — identifies EEPROM failure

The CI assembly consists of two circuit cards which come as one assembly. One of the circuit cards is a digital card (A1) and the other is an analog card (A2). Each card is referred to as a subassembly.

**DIGITAL SUBASSEMBLY**

**CUSTOM HYBRID AND GATE ARRAY** — The digital subassembly contains the custom hybrid, which is the brain center of the EFP. The custom hybrid consists of a CMOS EPROM, NMOS EEPROM, and an 80C31 8-bit microprocessor. The custom hybrid works together with the gate array to detect and decode command and data information.

**A** **CONTINUOUS WAVE (CW) KEY** — A cw telegraph key is normally used with a headset, but it can also be used with a handset. When a cw signal is set active, it is routed from the audio filter to the custom hybrid microprocessor via FCWKEY. The microprocessor then commands the gate array, via data bits DO thru D7, to activate a cw key signal to the audio control hybrid via --CWKEYRT. This signal to the audio control hybrid of the modulator/demodulator activates the keyline circuits and internal 1-KHz modulation tone circuits.

**A** **PUSH-TO-TALK (PTT)** — With a handset or headset and microphone, transmit operation is initiated with the PTT button. When the PTT signal is set active, it is routed through the audio filter and converted by the RS-422 receiver of the analog subassembly into levels acceptable by the microprocessor. This signal is -PTTB. When -PTTB is set active to the microprocessor, the microprocessor sends data information to the gate array to activate -PTTRT to the audio control hybrid and transmit enable (TXEN). TXEN is routed to the harmonic filter select circuit as high for transmit operation and low for receive operation.

**A** **CLEAR-TO-SEND (CTS)** — An external modem can be connected to the audio connector of the RT for external data mode operations. The radio set is used to transmit and receive baseband information during normal and ECCM operations. When a controller is used, the -CTS signal controls the receipt and transfer of data between the EFP and the modem.

When a controller is used, controller interface is provided by part of connector J1. The controller interface is used to buffer incoming/outgoing control words between the controller and the microprocessor. Differential data is transferred to and from the controller using serial data out (SDO) and serial data in (SDI) lines, respectively. The RS-422 receiver converts the SDO differential data into levels acceptable by the custom hybrid. SDI is converted into differential levels by the RS-422 driver and sent to the controller.

**C** **TUNE-IN-PROCESS (TIP)** — The TIP signal is received from the audio control hybrid during the tuning cycle. Tuning time averages approximately 3 seconds but may take up to 12 seconds. During tuning, -TIP is sent to the gate array, which activates -TPIC to the custom hybrid. Data or voice transmission is inhibited during tuning.

**C** **TUNEFAULT** — The Tunefault signal is generated by the antenna tuner of the amplifier/coupler. A tunefault occurs when tuning of the radio has not occurred within 12 seconds of the tune start operation or when an illegal frequency has been selected on the EFP panel. When one of these conditions occurs, TUNEFAULT is activated to the gate array from the audio control hybrid of the modulator/demodulator. The gate array sends TUNEFLTC to the custom hybrid and data or voice transmission is inhibited.

**C** **LCD PANEL INTERFACE** — The gate array receives information from the custom hybrid via data bits DO thru D7 to display operation information on the LCD panel. The custom hybrid tells the gate array to continually cycle outputs X1 thru X4 to the LCD panel. When one of the FREQUENCY KHz or MODE pushbuttons is pressed, a switch matrix closes the appropriate switch and information as to which button was pressed is transferred to the gate array via Y1 thru Y3. This information is used to display the frequency and mode on the LCD panel display via LCD DATAIN when clocked in by -DISCLK. The display is enabled by -DISEN, and the LCDS are refreshed by the 76 Hz signal.

**C** **HEATER** — When a FREQUENCY KHz or MODE pushbutton is pressed, heater control (HTR CTRL.) from the custom hybrid applies a high to a MOSFET switch in the analog subassembly. HTR CTRL is active for 40 seconds after pressing a pushbutton. Further switch actions within the 40-second interval will not extend the on time of HTR CTRL. However, when the 40-second interval has completed, the next pushbutton pressed starts a new 40-second interval when HTR CTRL is active.

**B** **FREQUENCY INFORMATION** — Information as to which frequency has been selected is sent to the gate array by Y1 thru Y3. The gate array loads the information to the synthesizer via frequency select outputs 10 MHZ1, and 2, 1MHZ1, 2, 4, and 8, 100KHZ1, 2, 4, and 8, 10KHZ1, 2, 4, and 8, 1KHZ1, 2, 4, and 8, and 100HZ1, 2, 4, and 8. Which lines are activated depends upon which frequency is selected on the front panel. The tables on page 2-24 illustrate the correlation between the frequency select switches and the frequency select outputs.

**CONTROL INTERFACE ASSEMBLY (2 of 7)**

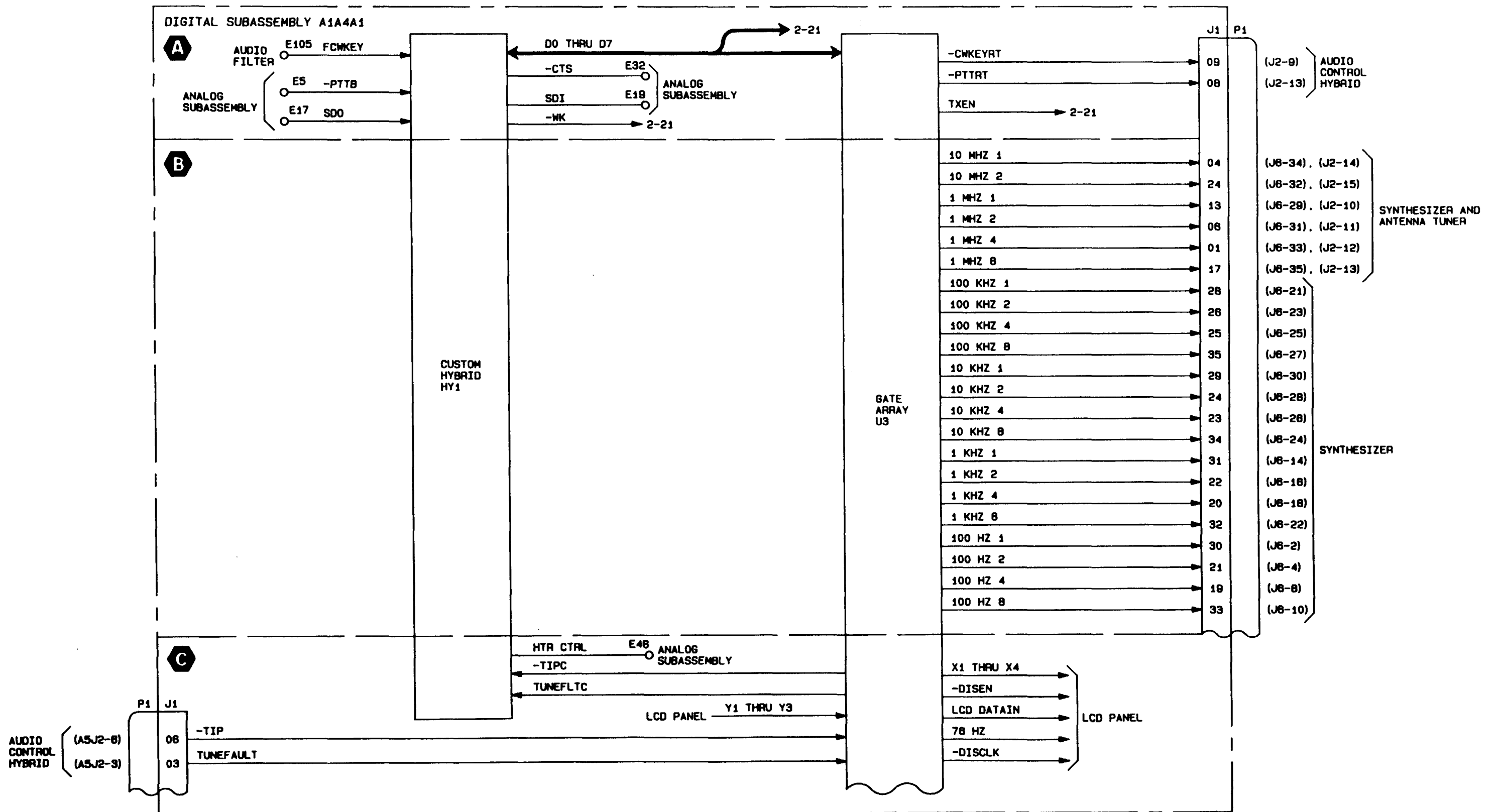

Figure 2-7. Control Interface Assembly (Sheet 1)

**CONTROL INTERFACE ASSEMBLY (3 of 7), fig 2-7, sh 2**

- A** RF BLANK — The rf blank signal is used to disable the transmit and receive energy during frequency transitions. In both transmit and receive operations, rf blank is set active while frequency information is loaded into the synthesizer.
- A** FREQUENCY CHANGE — The frequency change (AF) signal is generated each time a new operating frequency is selected. The AF signal is momentary (grid) during each change when setting the frequency select switches. The AF signal indicates to the audio control hybrid that a new frequency has been selected.
- A** DATA ENABLE — The data enable signal carries information to the audio control hybrid as to which operational mode has been selected. If the data mode is chosen, data enable is high. If voice mode is chosen, data enable is low.
- A** SPEAKER ATTENUATE — The speaker attenuate (-SPKRATTEN) signal is not used in non-ECCM mode. In ECCM operation, this signal attenuates the receive audio signal to the audio filter to control the loudness of the tones transmitted by the controller (when one is used).
- A** AUTOMATIC GAIN CONTROL (AGC) AND AUTOMATIC LEVEL CONTROL (ALC) — AGC and ALC operations are used in the ECCM mode of operation only. AGC data is analyzed in receive operation while ALC data is analyzed in transmit operation. In both transmit and receive operation, the read data cycle is initiated by the open loop (-OP LOOP) command from the gate array to the frequency converter of the modulator/demodulator.
- B** ANALOG-TO-DIGITAL (A/D) CONVERTER — When -OP LOOP is active, and the read enable (-A/D RD) for the A/D converter is active, AGC/ALC read (AGC/ALC RD) from the frequency converter is converted into an 8-bit digital code by the A/D converter. This digital code represents the input voltage and is sent to the microprocessor (DO thru D7) for decoding when -A/D LOAD, the D/A write enable, is activated.
- C** DIGITAL-TO-ANALOG (D/A) CONVERTER — The AGC/ALC RD signal is transferred to the D/A converter, via DO thru D7, as an 8-bit data word from the microprocessor when write enable (-WR) is set active. The digital signal is converted into an analog voltage (AGC/ALC WRA) and routed to the driver of the analog subassembly when D/A write enable (-D/A WR) is set active from the gate array.

- D** HARMONIC FILTER SELECT — The harmonic filter select circuit is an eight-gate Darlington transistor array. It accepts inputs transmit enable (TXEN), lower sideband select (LSB), and harmonic filter A thru F (HFA thru HFF) from the gate array. Data bits DO thru D7 from the custom hybrid provide information to the gate array as to which mode and frequency band have been selected.

If the transmit mode is selected, then TXEN to the harmonic filter select is high, and active low -TXEN is sent to 28 V switches. If the receive mode is selected, then TXEN is low, and -TXEN is inactive. If the lower sideband mode is selected, LSB to the harmonic filter select is high, and active low -LSB is sent to the 28 V switches. If the upper sideband mode is selected, then LSB is low and -LSB is inactive.

Depending upon which frequency band the radio is operating in, the appropriate input HFA thru HFF is high to the harmonic filter select. The tables on page 2-24 illustrate which of these inputs are active for each frequency on the display panel. The corresponding active low output (-HFA thru -HFF) is sent to the harmonic filter. The following table lists the harmonic filter select outputs and their corresponding frequency bands.

Output Signal	Frequency Band
-HFA	2-3 MHz band
-HFB	3-5 MHz band
-HFC	5-8 MHz band
-HFD	8-12 MHz band
-HFE	12-20 MHz band
-HFF	20-30 MHz band

- E** 28 V SWITCHES — If the transmit mode is selected, then TXEN to the harmonic filter select is high, and active low -TXEN is sent to 28 V switches. Transmit mode is then enabled by 28V TXEN to the audio control hybrid. If receive mode is selected, then the opposite occurs and 28V TXEN is inactive. If the lower sideband mode is selected, LSB to the harmonic filter select is high, and active low -LSB is sent to 28 V switches. This turns on the switches and LSB 28V is activated to the synthesizer. The opposite occurs when the upper sideband mode is selected.

CONTROL INTERFACE ASSEMBLY (4 of 7)

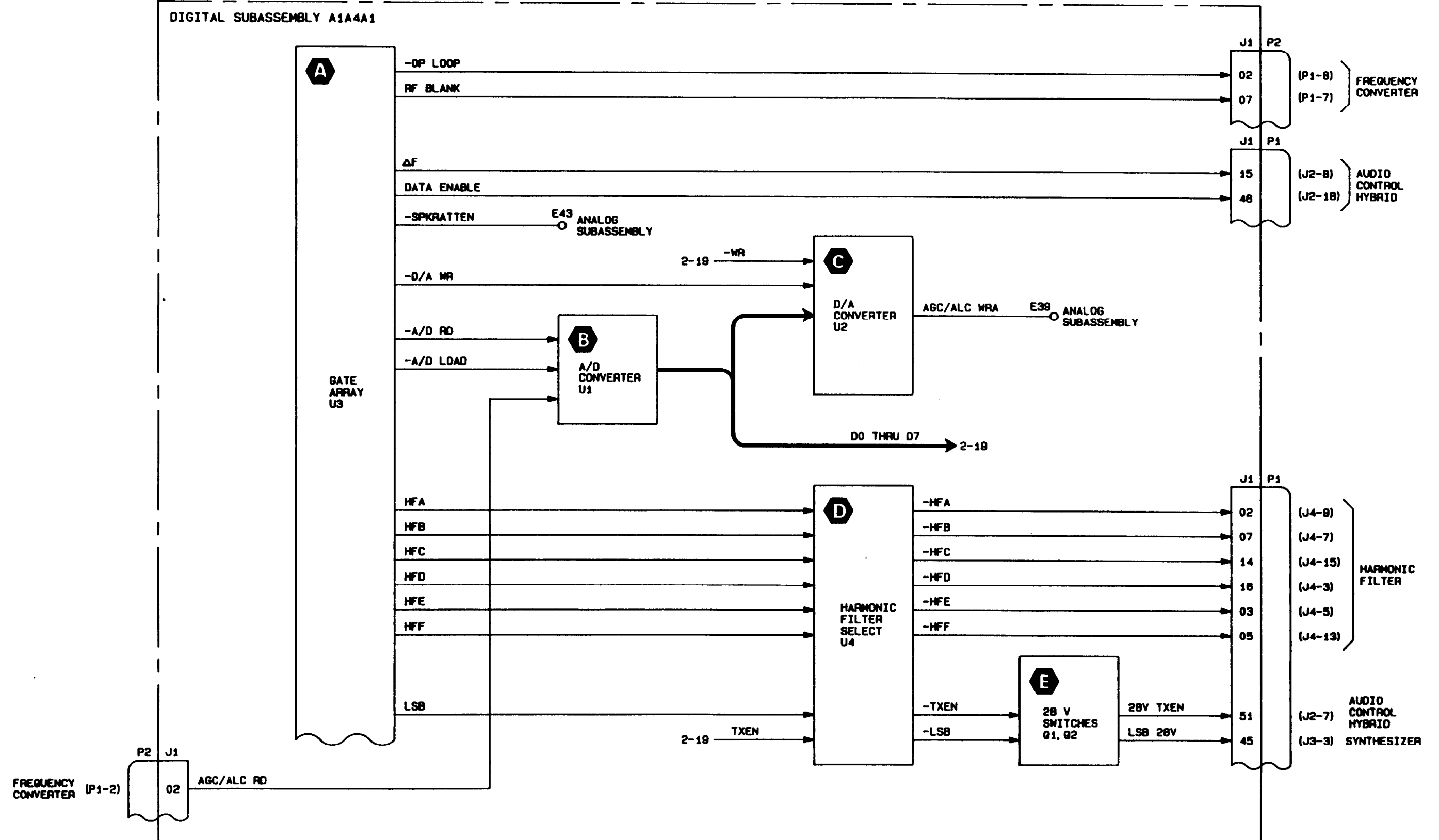

Figure 2-7. Control Interface Assembly (Sheet 2)

**CONTROL INTERFACE ASSEMBLY (5 of 7), fig 2-7, sh 3**

**ANALOG SUBASSEMBLY**

**RS-422 DRIVER AND RECEIVER** — The analog subassembly contains the RS-422 interface which consists of the RS-422 driver and receiver. The RS-422 interface carries serial data at the transmission rate of 156K bits-per-second and a 1.25 MHz clock signal.

**A** The RS-422 driver accepts differential serial data and converts it to RS-422 signal levels. When a controller is used, differential serial data from the digital subassembly's custom hybrid is input to the RS-422 driver via input serial data in (SDI). This data is then converted and transferred to the STAJ controller as serial data in + (SDI+) and serial data in - (SDI-). Similarly, the differential master clock for the controller is converted from 1.25MHZ from the custom hybrid to levels acceptable by the controller as 1.25MHZ+ and 1.25MHZ-.

**B** The RS-422 receiver performs the opposite function of the driver. When a controller is used, RS-422 signal levels received from the controller are converted to levels acceptable by the custom hybrid. These input signals include serial data out + (SDO+) and serial data out - (SDO-), as well as the push-to-talk (FPTT) signal. The corresponding outputs are SDO and -PTTB.

**C** **SPEAKER ATTENUATE** — In ECCM operation, the speaker attenuate circuit attenuates the receive audio (FRCV AUDIO) signal to the audio filter to control the loudness of the tones transmitted by the STAJ controller. These tones are heard as sidetone. This function is activated by the speaker attenuate control (-SPKRATTEN) from the gate array and is not used in non-ECCM mode.

**MOSFET SWITCHES** — The analog subassembly contains several metal oxide semiconductor field effect transistor (MOSFET) switches.

**D** One set of MOSFET switches is used to apply +28 V to the light and heater circuits of the digital subassembly and to the STAJ controller, when one is used. The +28 V is applied to the switches from the amplifier/coupler Interface via +28VF. When the VOLUME OFF/MAX control switch is closed, ground is applied to a MOSFET switch via volume switch (VOL SW). The MOSFET switch turns on, applying +28 V to the STAJ controller and to other MOSFH switches. When the LIGHT pushbutton switch is pressed, ground is applied to the other MOSFET switches via light control (-LGHT) and 28V LIGHT is sent to the LCD panel to backlight the display.

Whenever one of the FREQUENCY KHz or MODE pushbuttons on the front panel is pressed, heater control (HTR CTRL) from the custom hybrid applies a high to the heater control MOSFET switch. This turns on the MOSFET and applies 28V heater (28V HTR) to the LCD panel. When the thermistor in the LCD detects a temperature that requires heat to be applied to the LCDS for proper operation, the thermistor applies a ground to one side of the heater. With 28V HTR applied to one side of the heater element and a ground applied to the other side, current flows through the heater element and heat is applied to the LCDS. The HTR CTRL signal is active for 40 seconds after pressing a pushbutton. Further switch actions within the 40-second interval will not extend the on time of HTR CTRL. However, when the 40-second interval has completed, the next pushbutton pressed starts a new 40-second interval when HTR CTRL is active.

**E** Another MOSFET switch is used to control the clear-to-send signal. The custom hybrid activates the -CTS signal to the MOSFET, which turns on the switch and sends FCTS to the audio filter.

**F** **AMPLIFIER** — During transmit operations when a controller is used, before actual voice or data operations, the controller sends baseband preamble information to the control panel. This information is sent on the modem transmit (MODEM TX) line and is routed to the audio control hybrid. This baseband preamble information is used to correlate the STAJ controller in the transmitting radio set to the controller in the receiving radio set. In receive operations, baseband preamble audio from the audio control hybrid is trapped off the TO VOLCTRL signal. The audio is amplified by the amplifier and routed to the STAJ controller as modem receive (MODEM RX). These operations occur in ECCM mode only.

**G** **DRIVER** — When the AGC/ALC signal is converted from an 8-bit digital word to an analog voltage by the D/A converter, it is sent to a driver. The driver amplifies the analog voltage AGC/ALC WRA, and routes it to the frequency converter as AGC/ALC write data (AGC/ALC WR). This operation does not occur in non-ECCM operation.



**CONTROL INTERFACE ASSEMBLY (6 of 7)**

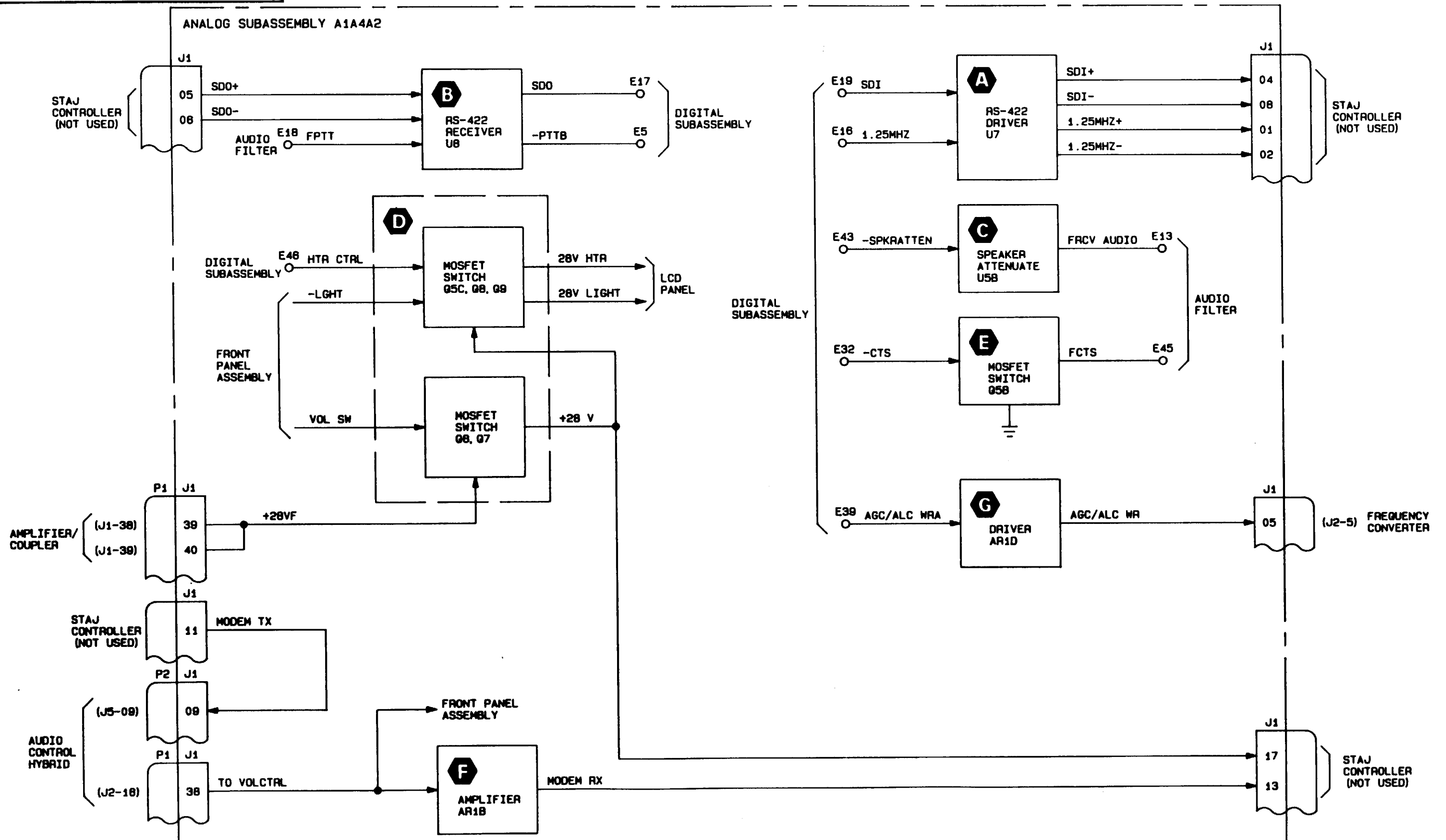

Figure 2-7. Control Interface Assembly (Sheet 3)

**CONTROL INTERFACE ASSEMBLY (7 of 7)**

**GATE ARRAY FREQUENCY SELECT AND HARMONIC FILTER SELECT OUTPUTS**

**NOTE**

F1 thru F6 represent the leftmost to the rightmost FREQUENCY KHz pushbuttons, respectively.

F1 EFP Display	Frequency Select 10 MHz2-10 MHz1	Active Harmonic Filter Select HFA-HFF
1	0 1	HFE
2	1 0	HFF
0	0 0	None

F2 EFP Display	Frequency Select 1 MHz8-1 MHz1	Active Harmonic Filter Select HFA-HFF
1	0 0 0 1	None
2	0 0 1 0	HFA
3	0 0 1 1	HFB
4	0 1 0 0	HFB
5	0 1 0 1	HFC
6	0 1 1 0	HFC
7	0 1 1 1	HFC
a	1 0 0 0	HFD
9	1 0 0 1	HFD

F3 EFP Display	Frequency Select 100 KHz8-100 KHz1	Active Harmonic Filter Select HFA-HFF
1	0 0 0 1	None
2	0 0 1 0	None
3	0 0 1 1	None
4	0 1 0 0	None
5	0 1 0 1	None
6	0 1 1 0	None
7	0 1 1 1	None
8	1 0 0 0	None
9	1 0 0 1	None

F4 EFP Display	Frequency Select 10 KHz8-10 KHz1	Active Harmonic Filter Select HFA-HFF
1	0 0 0 1	None
2	0 0 1 0	None
3	0 0 1 1	None
4	0 1 0 0	None
5	0 1 0 1	None
6	0 1 1 0	None
7	0 1 1 1	None
8	1 0 0 0	None
9	1 0 0 1	None

F5 EFP Display	Frequency Select 1 KHz8-1 KHz1	Active Harmonic Filter Select HFA-HFF
1	0 0 0 1	None
2	0 0 1 0	None
3	0 0 1 1	None
4	0 1 0 0	None
5	0 1 0 1	None
6	0 1 1 0	None
7	0 1 1 1	None
8	- 1 0 0 0	None
9	1 0 0 1	None

F6 EFP Display	Frequency Select 100 Hz8-100 Hz1	Active Harmonic Filter Select HFA-HFF
1	0 0 0 1	None
2	0 0 1 0	None
3	0 0 1 1	None
4	0 1 0 0	None
5	0 1 0 1	None
6	0 1 1 0	None
7	0 1 1 1	None
8	1 0 0 0	None
9	1 0 0 1	None

**AUDIO FILTER ASSEMBLY, fig 2-8**

The audio filter assembly provides an LC filter network for pins B thru F of the audio connector used by the RT. The audio filter biddirectionally filters noise from/to an external audio device to/from the RT. Audio return (AUDIO RTN) is the ground reference on the connector and FAUDIO RTN is the ground reference on the RT. The following tables list the signal names and give descriptions for each input and output.

The following tables list the signal names and give descriptions for each input and output.

**AUDIO FILTER INPUTS**

Signal Name	Description
AUDIO RTN	Ground.
FRCV AUDIO	Audio input from radio to handset speaker.
PTT	Open or grounded inputs. Grounding activates push-to-talk function.
XMT AUDIO	Audio input from microphone in handset.
CW KEY	Open or grounded input. Grounding activates the cw key function.
FCTS	Clear-to-send signal When true, signal enables transmission/receipt of data.

**AUDIO FILTER OUTPUTS**

Signal Name	Description
FAUDIO RTN	Ground.
FCV AUDIO	Audio output to handset speaker.
FPIT	Push-to-talk signal to radio.
FXMT AUDIO	Microphone audio from handset to radio.
FCW KEY	Cw key signal to radio.
CTS	Clear-to-send signal When true, signal enables transmission/receipt of data.

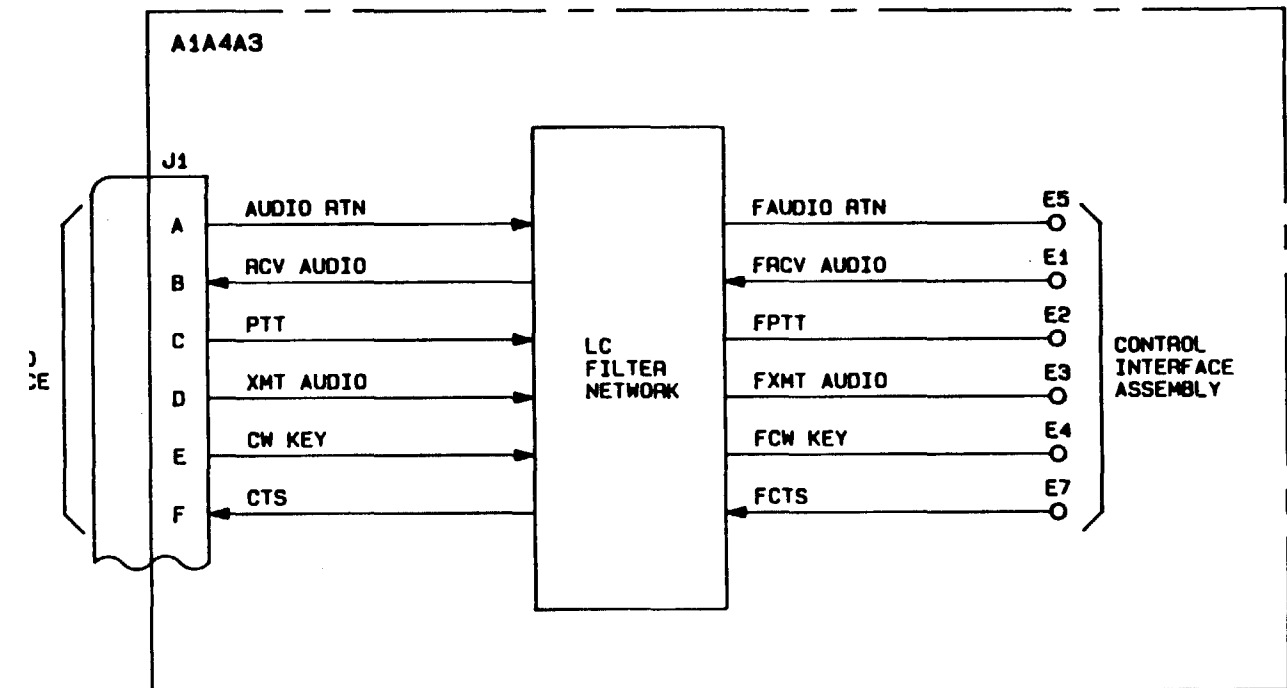

Figure 2-8 Audio Filter Assembly

**SYNTHESIZER (1 of 4), fig 2-9, sh 1**

The synthesizer provides input to the modulator/demodulator frequency converter in the form of three high frequency LO signals and one audible tone. The high frequency LO signals are 5 MHz, 70/80 MHz, and 77-105 MHz.

**B** 77-105 MHz VOLTAGE-CONTROLLED OSCILLATOR (VCO) (1ST LO) — The synthesizer uses fractional-N synthesis technology to generate a 1st LO signal with fast lock-up time. For changes in frequency steps equal to or larger than the reference frequency (100 KHz), the 1st LO loop functions as a conventional sample and hold phase-locked loop (PLL) with an integer divider number. Assuming phase lock, the VCO output is first divided by the 10 or 11 prescaler (+10/11) and programmable divider (+N) in the digital logic array.

**B** The digital logic array output is a 100-KHz sampling pulse that samples a small portion of a 100-KHz voltage ramp generated by the ramp generator circuit and a 100-KHz reference signal. This sampled ramp voltage is stored on the hold capacitor (C22) within the ramp generator and then through a loop filter (AR2) to tune the VCO. When a new frequency is selected, the programmable divider is changed, and the sample and ramp are out of phase. This causes the ramp to be sampled either early or late, which sends a smaller or larger (respectively) tune voltage to the 1st LO VCO to change frequency.

**A** For frequency steps smaller than the reference frequency, such as 10 KHz, 1 KHz, and 100 Hz, fractional divisor numbers are used. This is accomplished in the digital logic array by toggling the integer divider between N and N + 1. For example, if the integer divider divides by N for 9 counts and N + 1 for 1 count, then the divide ratio is  $(9N + N + 1) / 10 = N + 0.1$ , and a fractional divisor number is then realized. For instance, if N = 770 (a non-fractional divide number), then the VCO frequency ( $f_{vco}$ ) is equal to

$770 \times 100 \text{ KHz} = 77.0 \text{ MHz}$ . However, if a 10-KHz step is required, then  $N = 770.1$  and  $f_{vco} = 770.1 \times 100 \text{ KHz} = 77.010 \text{ MHz}$ . This same example can be made for 1-KHz offsets using 1000 count averages and 100-Hz offsets using 100 count averages.

**A** It should be noted that at any discrete point in time, the divider is not dividing by the required fractional divisor, so errors in the tune voltage and output voltage occur. The VCO tune error voltage is proportional to the offset frequency and the timing within the 0-10, 0-100, and 0-1000 count sequence. The gate array generates error correction control pulses to the ramp generator circuit, which are proportional to the offset frequency. These current switch pulses increase the slope of the voltage ramp in proportion to the frequency offset. The increase in slope occurs before the sample is taken, generating an offset (error correction) VCO tune voltage proportional to the offset. Proper alignment of 1-KHz and 10-KHz phase adjust potentiometers (inside the ramp generator submodule) adjusts the error correction voltage, which cancels the error voltage generated by the fractional division. The result is fractional division with the correct discrete time VCO output frequency.

**A** A coarse tune voltage is generated that presets (in 1-MHz steps) the 1st LO VCO near the final selected frequency. This reduces the initial frequency offset for large frequency steps, reducing the time required for phase setting. The 1-MHz and 10-MHz (and to some extent the 100-KHz) frequency select lines from the EFP control the coarse tune voltage. From the EFP, the BCD frequency select signals drive a D/A converter within the 77-105 MHz submodule. A coarse tune voltage of approximately 3-9 V dc is generated when the EFP frequency control switches are set from 77.0 to 104.0 MHz. Offset and gain adjustments in the 77-105 MHz submodule ensure that the relationship between the coarse tune voltage and desired frequency settings are within the required range.

SYNTHESIZER (2 of 4)

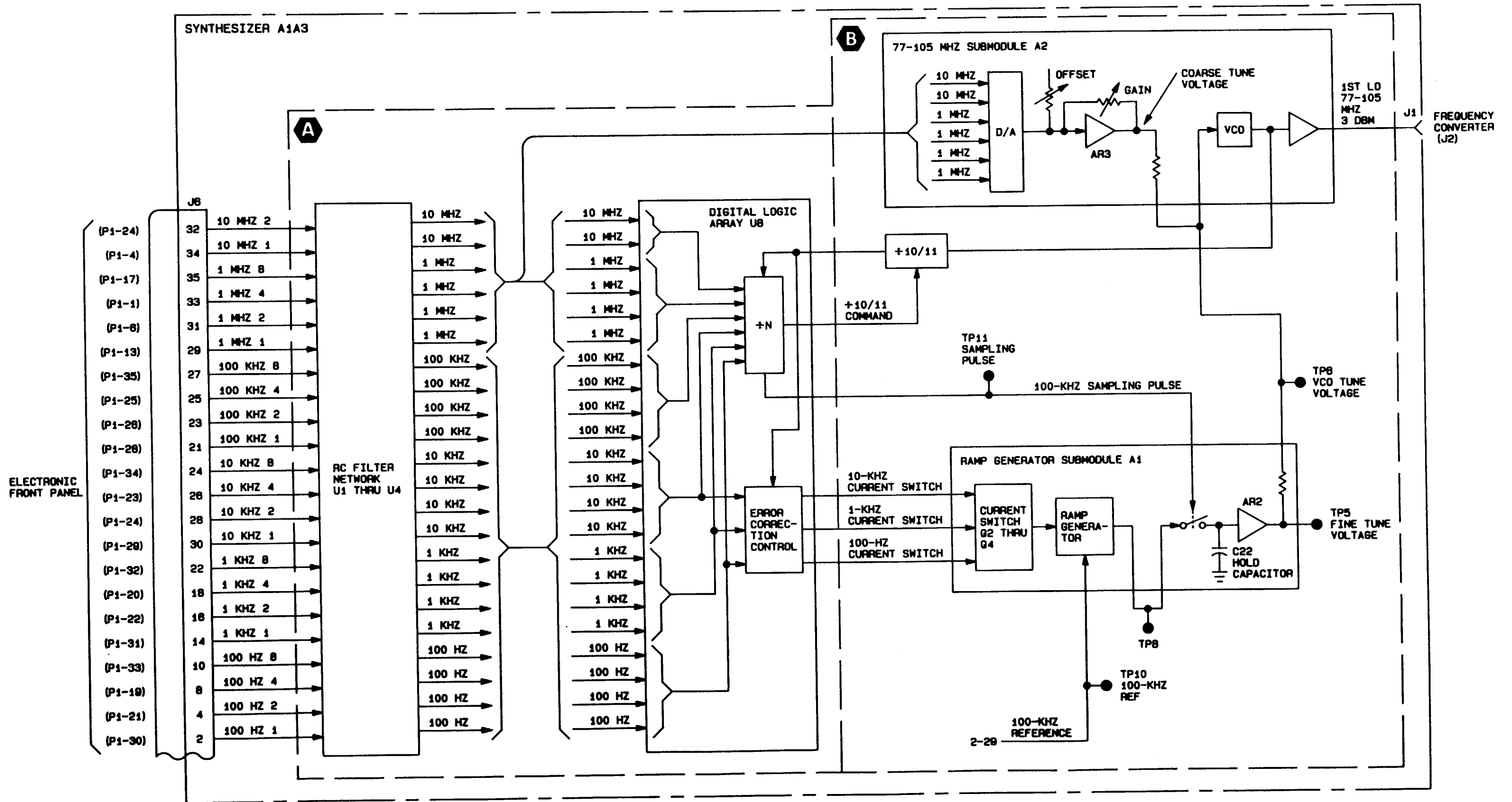

Figure 2-9. Synthesizer (Sheet 1)

**E** 70/80-MHZ LO (2ND LO) — The 70 MHz upper sideband (USB) or 80 MHz lower sideband (LSB) signal is generated by a VCO. The complete circuit uses a PPL consisting of the VCO, a divide-by-10 circuit, a divide-by-7 or -8 circuit, phase detector, and loop filter. The 2nd LO output signal is routed to J2 of the synthesizer printed wiring board (PWB) at a level of -4.0 dBm.

Within the 70/80-MHz VCO submodule, the VCO output frequency is first divided by 10, then by 7 or 8, depending on the position of the EFP sideband selection switch. The resulting signal is then compared with the 1 MHz reference signal at the phase detector ( $\phi$  det U2). If phase synchronization is established between the two signals, the phase detector and loop filter circuits do not generate a correction signal to the VCO. If the two signals are not in phase, the phase detector and loop filter circuits generate a correction tune voltage to the VCO until the divide-by-7 or -8 circuit output and the 1-MHz reference signals are in phase.

**C** **D** 5-MHZ LO (3RD LO) — The 5-MHz 3rd LO signal is generated by a temperature-controlled crystal oscillator (TCXO). The TCXO generates the synthesizer 5-MHz 3rd LO output at J3, and additionally furnishes a stable reference frequency for the 1st and 2nd LO and 1-KHz tone circuits. If desired, an external 5-MHz reference signal can be connected to J4 of the synthesizer in place of the TCXO. Two jumper wires located on the synthesizer PWB must be properly positioned, depending on whether the internal (TCXO) or external 5-MHz reference is desired.

**C** **D** The TCXO output signal drives a FET voltage amplifier (Q1) and a dual common base amplifier (Q2) within the 5-MHz converter assembly. The FET amplifier generates a 5-MHz TTL compatible signal to J5, which furnishes a TTL reference to the EFP. Q2 generates the 5-MHz LO at 0 dBm to J3. Q2 also drives a TTL compatible voltage amplifier (Q3) that generates an AUX 5 MHz signal for the synthesizer reference circuits.

**E** SYNTHESIZER REFERENCE SIGNALS — Two reference signals are required for the synthesizer. The first is 1 MHz used as the reference for the 70/80 MHz VCO PPL circuit. This signal is derived from the AUX 5 MHz output of the 5-MHz converter and divided by 5 in a TTL counter. The second reference signal required is 100 KHz for the 77-105 MHz VCO sample and hold PLL circuitry (page 2-27). This signal is derived by dividing by 10 the 1-MHz reference at U6 of the synthesizer PWB.

**D** 1-KHZ TONE OUTPUT — A 6 V peak-to-peak tone signal is required by the modulator/demodulator audio control hybrid. It is obtained by further dividing the 100-KHz reference signal by 100 at U7, and then filtering the resultant 1-KHz square wave through an active filter to obtain a more sinusoidal output waveform.

**SYNTHESIZER (4 of 4)**

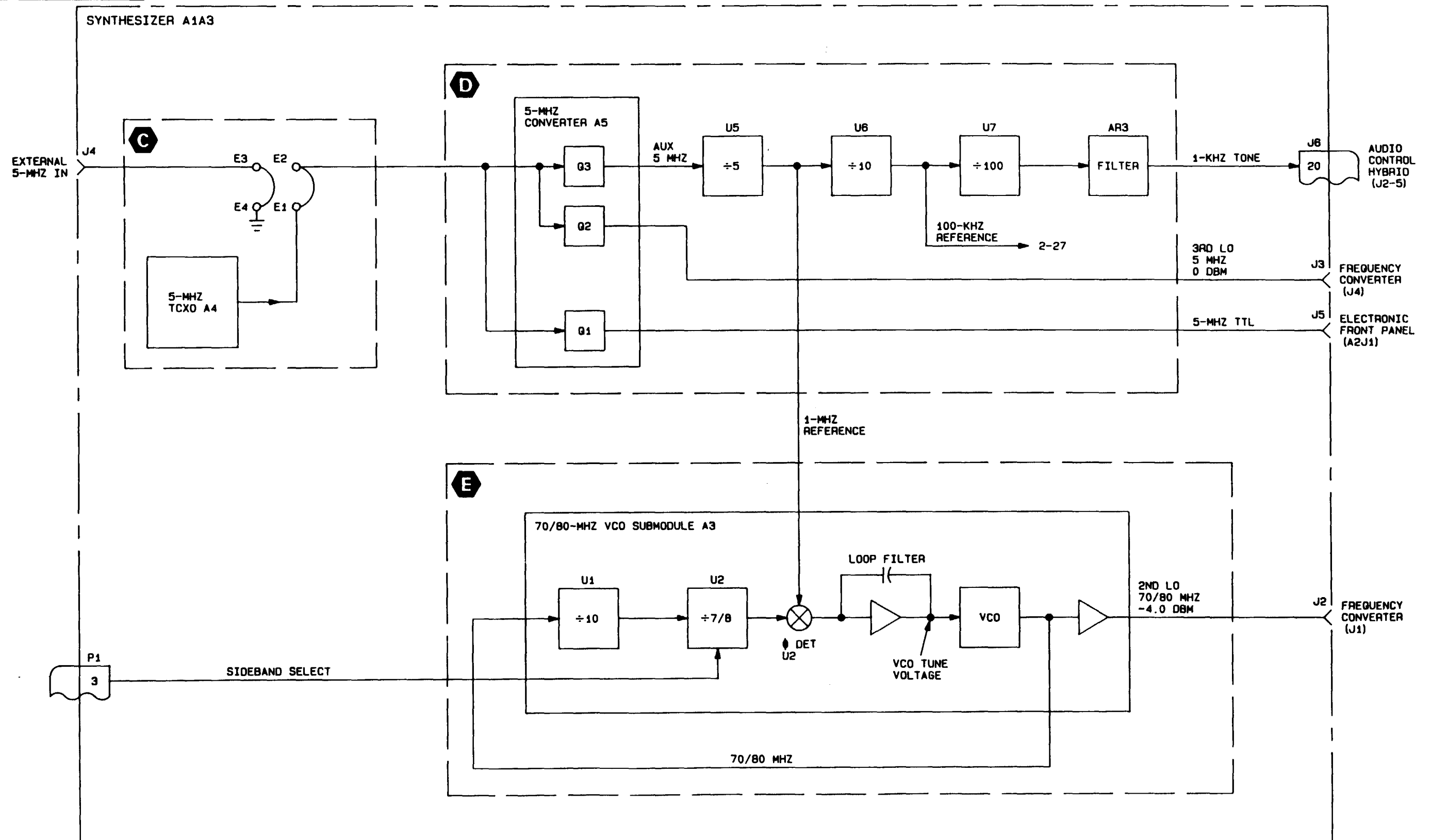

Figure 2-9. Synthesizer (Sheet 2)

**70/80 MHz VOLTAGE-CONTROLLED OSCILLATOR (VCO), fig 2-10**

This submodule contains a voltage-controlled oscillator and an RF amplifier that generates the 70 or 80 MHz 2nd LO output. Also in this submodule are a fixed divide-by-10, a dual modulus divide-by-7 or -8, a digital phase/frequency detector and a loop filter.

A 1-MHz reference pulse (approximately 0 to 10 volts) feeds one input to the phase/frequency detector and the VCO output divided by the dividers mentioned is fed to the other. An error signal proportional to the phase error between these two signals is filtered by the loop filter and used to tune the VCO until no error exists. In this way, the 2nd LO locks to either 70 or 80 MHz.

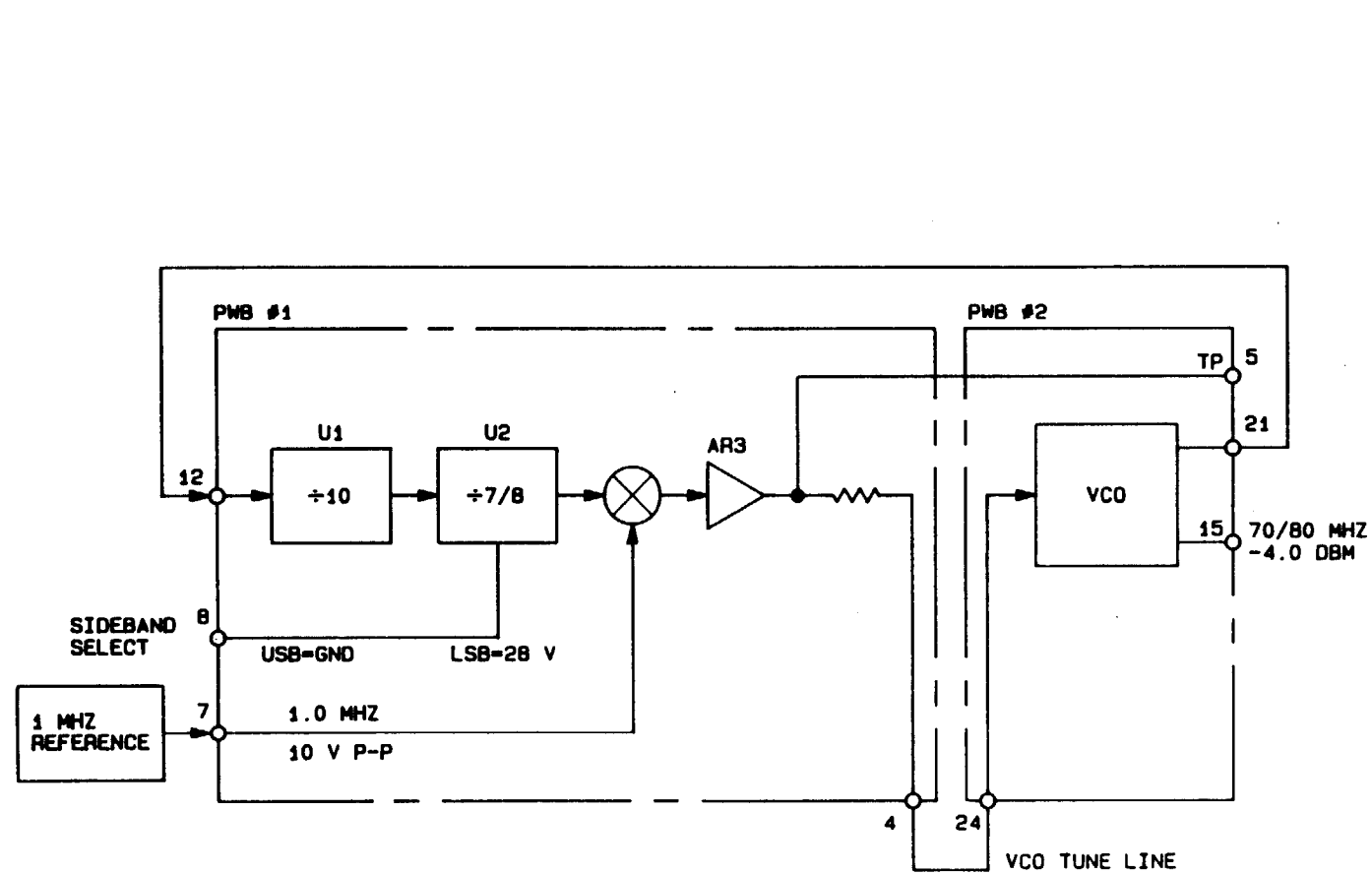

Figure 2-10. 70/80 MHz Voltage-Controlled Oscillator (VCO)

**77-105 MHz VOLTAGE-CONTROLLED OSCILLATOR (VCO), fig 2-11**

This submodule contains a voltage-controlled oscillator and an RF amplifier that generates the 77-105 MHz 1st LO output. Also in this submodule is a discrete 6-bit digital-to-analog converter. The 1 and 10 MHz frequency control bits are used to generate a control current that is converted into a control voltage. The voltage range is appropriately scaled and offset to preset the VCO near the selected frequency.

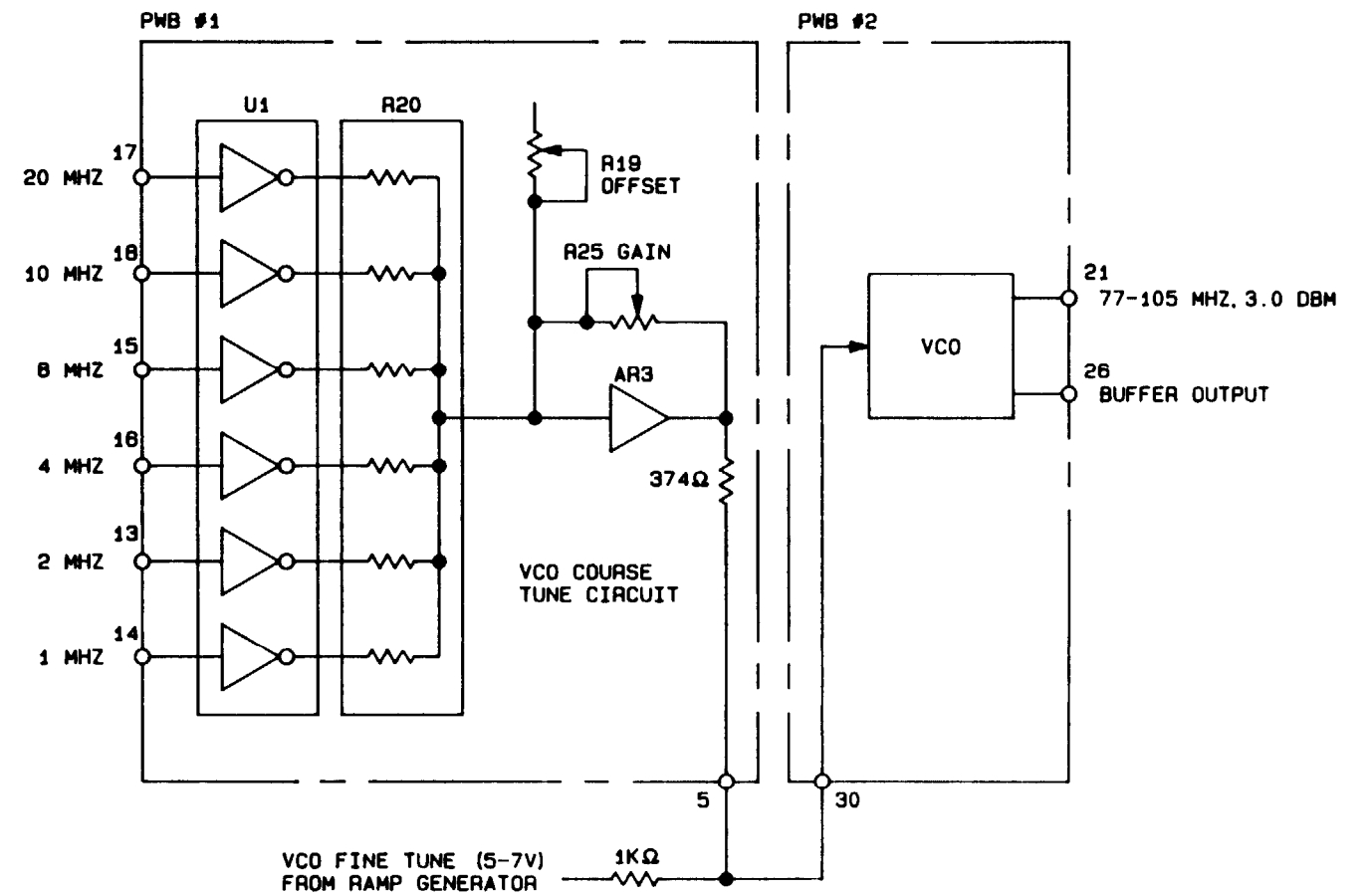

Figure 2-11. 75-105 MHz Voltage-Controlled Oscillator (VCO)



**RAMP GENERATOR, fig 2-12**

The ramp generator submodule is a discrete phase detector and loop filter for the 1st LO loop. Another feature of the ramp generator are the current switches (Q1 -Q4) used to perform Fractional-N error correction. A constant current source (Q8, Q9) and a current mirror (Q1, AR1 ) charge a fixed capacitor. Because

$$V = \frac{1}{C} \int_0^T i dt = \frac{it}{C} + \text{initial condition and } i \text{ is constant,}$$

a ramp voltage is generated by a ramp generator (Q5-Q7) with its slope proportional to the charging current. This ramp voltage is sent to one side of a diode bridge (AR2). The 100-kHz reference pulses from Q1 O reset the ramp voltage to zero for 1 μs. A sample pulse (from U2, Q11, T2, T1, CR5-CR8) is used to create two narrow pulses 180° out of phase which turn on and off the diode bridge, thus sampling the ramp. The sample voltage is held on a capacitor (C22) until the next sample pulse. The sample voltage fine tunes the 1st LO into phase lock.

During fractional-N turning, pulse-width modulated signals from the digital logic array turn on and off the current switches in the ramp generator. When the current switches are off, the ramp generator operates as before. When a current switch is on, more current is supplied by the constant current source, thus changing the ramp slope for a short time before the next sample is taken. This creates an offset (error correction) voltage proportional to the discrete frequency error inherent in fractional-N synthesis. The offset voltage is scaled such that fractional-N spurs are nulled.

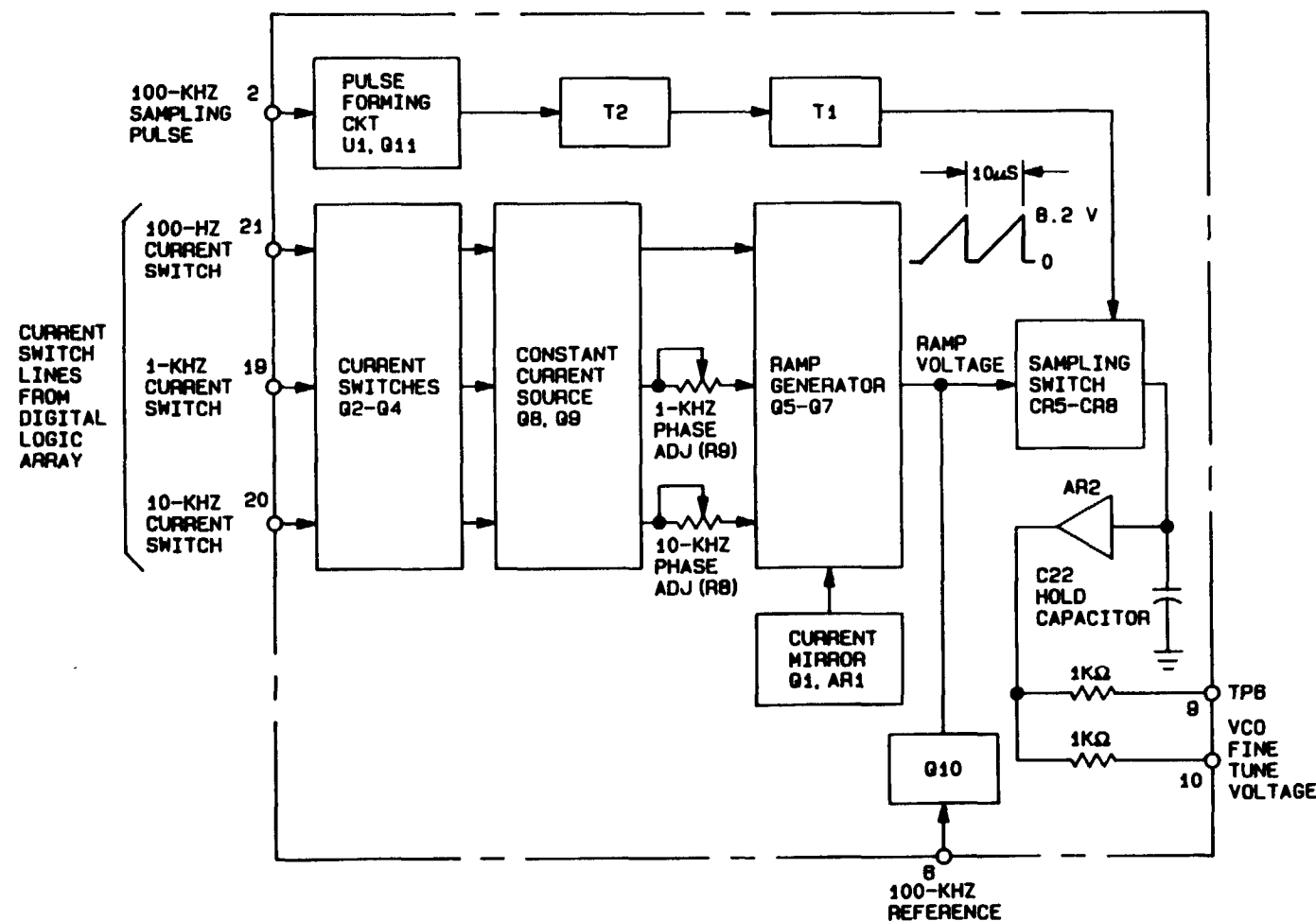

Figure 2-12. Ramp Generator

**5-MHZ CONVERTER, fig 2-13**

This submodule amplifies the 5-MHz TOXO signal to generate the required output signals for the modulator/demodulator assembly, the electronic front panel (EFP) assembly, and the synthesizer assembly. There are three functional circuits in the buffer drive assembly: (1) 5-MHz TTL driver (Q1), (2) 5-MHz auxiliary driver (Q2, Q3), and (3) 5-MHz buffer amplifier (Q2, T1 ).

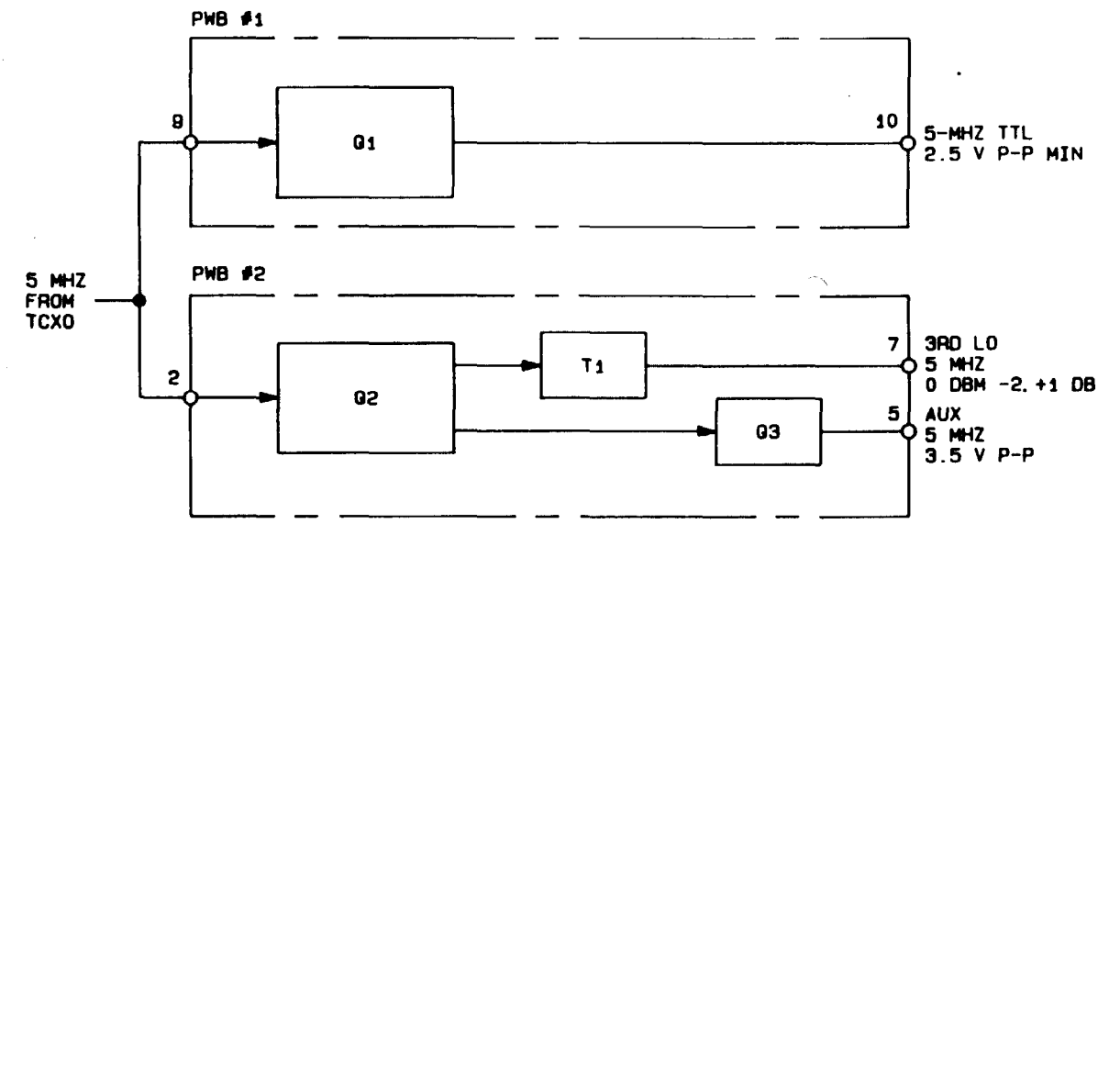

Figure 2-13. 5-MHz Converter

**MODULATOR/DEMOMULATOR (1 of 2), fig 2-14**

**GENERAL** — The modulator/demodulator performs audio-to-radio frequency conversion. It also coordinates other functions, such as level control, gain control fault signals, and tuning initialization. The modulator/demodulator contains the frequency converters and the audio control hybrid. The frequency converters are controlled by the audio control hybrid. The keyline signal from the audio control hybrid and the +28 V xmt enable from the EFP, determine whether the radio set is in transmit or receive operation.

**TRANSMIT OPERATION** — In transmit operation, the keyline signal and +28 V xmt enable are routed to the frequency converters, enabling the transmit circuits. Xmt audio is then processed by the audio control hybrid and sent to the frequency converters. The frequency converters translate the xmt audio frequency into two intermediate frequencies (if.) and then into xmt rf, which is routed to the power amplifier for further amplification.

**RECEIVE OPERATION** — in receive operation, the absence of the keyline signal places the frequency converters into receive mode. During receive operation, the frequency converters extract the rcv audio frequency from the incoming rcv rf signal (demodulation). The audio control hybrid processes rcv audio and routes it to the EFP.

**MODULATOR/DEMODULATOR (2 of 2)**

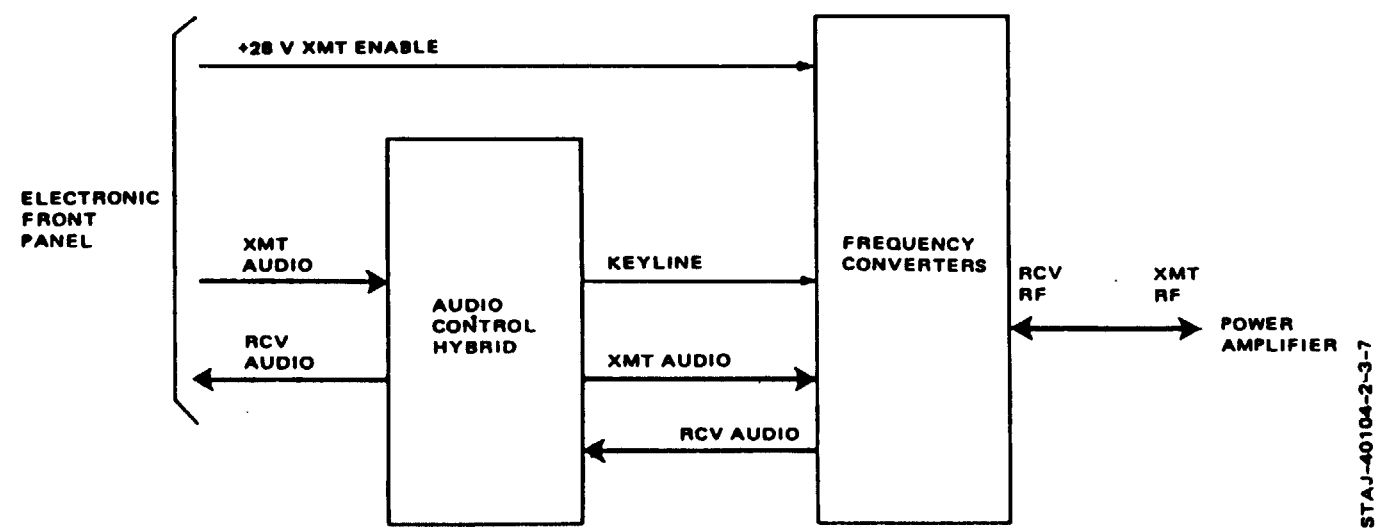

Figure 2-14. Modulator/Demodulator

**AUDIO CONTROL HYBRID (1 of 6), fig 2-15, sh 1**

**NOTE**

The audio control hybrid is not repairable, but the block diagram is necessary to understand the function. Therefore, no circuit designators are given.

**GENERAL** — The audio control hybrid contains the control circuits required by the modulator/demodulator to control and process xmt and rcv audio. The audio control hybrid also generates tune start, power amplifier (PA) off/on (not used in PRC-104; used with AM-6879/URC), and keyline signals.

**A** **TRANSMIT OPERATION** — Xmt audio is received from the EFP and routed to the audio control hybrid. In data transmission (DTR) mode, the data xmt audio is attenuated. The output of transmit audio is routed through the VOGAD bypass switch and AR1A to the third frequency converter for further processing and to the sidetone level adjust for use in sidetone operation.

When voice transmission (VTR) has been selected on the EFP and a handset is used, no attenuation of the signal takes place.

**B C** **CW KEY TRANSMISSION** — When VTR has been selected on the EFP and a telegrapher's key is used, the 1-kHz tone is received from the synthesizer and routed through the 1-kHz tone adjust and applied to the audio control hybrid. When the cw key signal is received from the EFP, the 1-kHz tone is routed through the audio control hybrid and VOGAD bypass switch to the third frequency converter and to the sidetone level adjust. The 1-kHz tone is present whenever the telegrapher's key is pressed (cw key 0). The audio control hybrid operates in the same manner during tune in progress to generate the tune in progress tone. The table below describes the logic for the 1-kHz electronic switch.

Input		Output at Pin 18 of Audio Control Hybrid
CW	Tune In Progress	
1	1	no signal
0	1	xmt audio
1	0	xmt audio
0	0	xmt audio

**VOICE-OPERATED GAIN ADJUSTMENT DEVICE (VOGAD) BYPASS SWITCH** — Xmt audio from the audio control hybrid is routed through the voice-operated gain adjustment device (VOGAD) bypass switch to the third frequency converter. The VOGAD bypass switch is used during preamble, continue, and postamble operations of the controller. Modem transmit (tx) is routed directly to the VOGAD bypass switch along with the VOGAD bypass signal from the EFP. When the VOGAD bypass signal is active, xmt audio from the audio control hybrid is disabled, allowing modem tx to pass through the VOGAD bypass switch to the third frequency converter. This allows the modem tx signal to pass directly to the third frequency converter without going through the attenuation and level control circuits of the audio control hybrid.

**A** **DATA TRANSMISSION** — When data transmission has been selected on the EFP, data enable enables xmt audio to be routed through the audio control hybrid. Xmt audio is attenuated to -56 dBm when the input is 0 dBm. Refer to the table below for audio control hybrid logic.

Input Data Enable	Xmt Audio
0	Not Attenuated
1	Attenuated

**B D** **RECEIVE OPERATION** — Rcv audio is received from the third frequency converter and routed to the audio control hybrid. The rcv audio input level is controlled by rcv audio level adjust R37. The rcv audio is then routed to the EFP and AGC receive audio is sent to the third frequency converter. The level of the rcv audio output is controlled by the level of the following signals: 100 µf, from vol control wiper, data switch level control, to vol control, sidetone audio, sidetone enable, and data enable.

AUDIO CONTROL HYBRID (2 of 6)

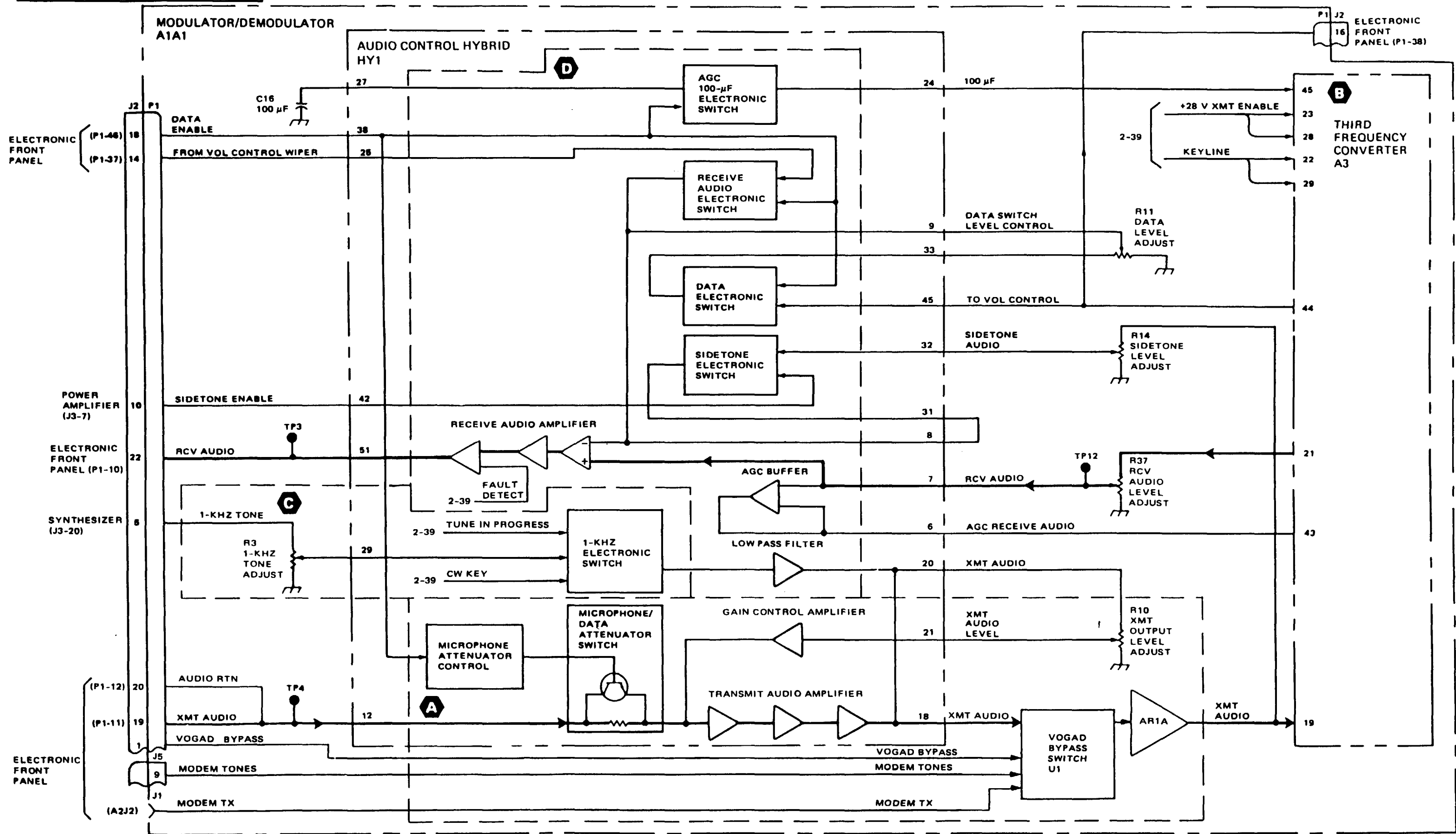

Figure 2-15. Audio Control Hybrid (Sheet 1)

STA-J-40104-2-3-8

**AUDIO CONTROL HYBRID (3 of 6), fig 2-15, sh 2**

**D** VOICE AND CW OPERATION - During voice or cw operation, the audio electronic switch is closed, routing the audio from vol control wiper to one of the differential inputs of the first stage of the receive audio amplifier. This signal controls the level of rcv audio frequency.

**D** DATA OPERATION — During data operation, the EFP opens the audio electronic switch and closes the data electronic switch. The to vol control signal is routed through the data level adjust to the input stage of the receive audio amplifier via data switch level control. This signal controls the level of rcv audio.

**D** SIDETONE OPERATION — During transmit operation, xmt audio is routed through the sidetone level adjust to the sidetone electronic switch as sidetone audio. Sidetone enable from the power amplifier closes the sidetone electronics switch, and a portion of the xmt audio is routed to the receive audio amplifier.

**D** 100- $\mu$ F ELECTRONIC SWITCH — When data enable is received from the EFP, the 100- $\mu$ F electronic switch switches a 100-microfarad capacitor out of the third frequency converter circuits via 100- $\mu$ F. The third frequency converter uses the 100-microfarad capacitor for the AGC release time constant. in voice mode, the AGC release time is approximately 1 second and in data mode, it is 0.1 second.

**AUDIO CONTROL HYBRID (4 of 6)**

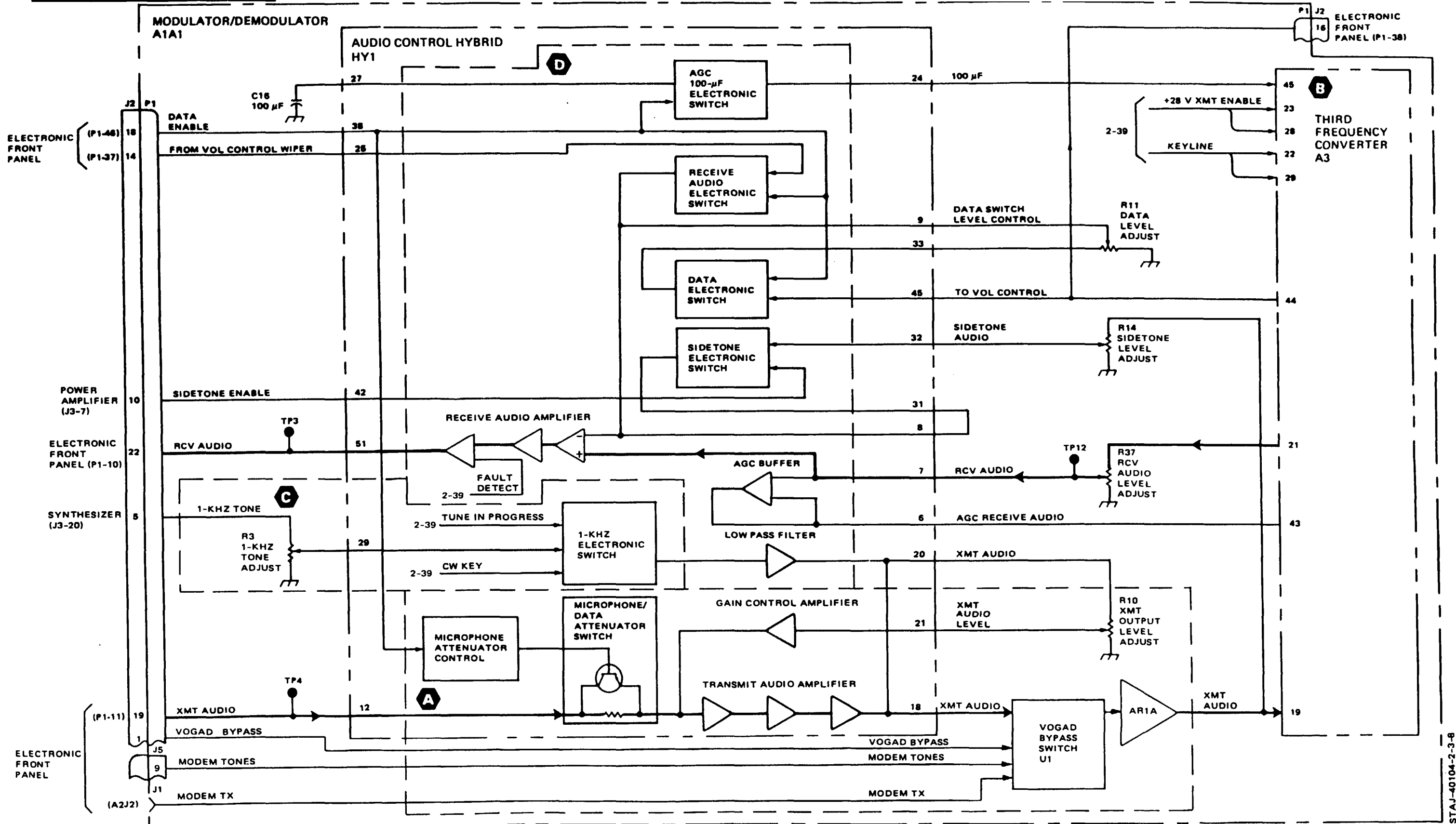

Figure 2-15. Audio Control Hybrid (Sheet 2)

STAJ-40104-2-3-8

**AUDIO CONTROL HYBRID (5 of 6), fig 2-15, sh 3**

**E** FREQUENCY CHANGE ( $\Delta F$ ) — The tune start logic is enabled when any of the following occur:

1. When the radio is first turned on.
2. When the FREQUENCY KHz settings (except for 100Hz) are changed on the EFP.
3. By the +28 V xmt enable signal when the MODE switch is reset to voice transmit (VTR) or data transmit (DTR) from a receive only mode.

The output of the +6.5 V switch Q3 is applied to the tune start control, which causes tune start switch Q1 to close, routing the tune start signal to the power amplifier, and antenna tuner. The tune start signal stays on (a ground) for a period of 65 milliseconds.

**F** TUNE/LOW VOLTAGE (LV) FAULT GENERATOR — The tune fault generator portion of the tune/LV fault generator generates a tune fault signal (repetitive beep) when tune fault is received from the antenna tuner. The low voltage fault generator portion of the tune/LV fault generator generates a low voltage fault tone (repetitive click) when +28 V on from the EFP, routed through the low voltage threshold adjust, drops below +20 V. The outputs of the tune and low voltage fault generators fault detect, are routed through the receive audio amplifier to the EFP and then to the handset. The tune fault signal is also generated when an illegal frequency is dialed into the EFP. Any frequency less than 2.0000 MHz is illegal.

**G** KEYLINE — The keyline logic signal is generated by the following:

1. +28 V xmt enable signal MODE switch on EFP set to WR or DTR and PIT signal received from the handset.
2. +28 V xmt enable signal and cw key signal received from telegrapher's key.

The keyline control is inhibited by the tune fault signal. If not inhibited, the keyline logic signal from the keyline control causes keyline switch Q5, Q6 to switch, routing the keyline signal to the first, second, and third frequency converters, power amplifier, and antenna tuner. The keyline signal switches all radio relays from the receive to transmit mode.

**H** ALC IN — In audio control hybrid HY1, ALC is routed through a buffer to ALC off/on. The reference voltage from the ALC offset adjust determines the threshold at ALC amplifier. The time constant of the ALC amplifier output, ALC, is adjusted by the ALC time constant switch. This occurs when the antenna tuner applies a tune in progress signal to the ALC time constant switch.

**E** PA OFF/ON CONTROL — The table below describes the PA off/on control logic. The PA off/on control is used with other configurations of the RT, but not the radio set.

Input +6.5 V Transmit Enable	PA Off/On Control Result
1	ON - (3.5 ma)
0	OFF - (0 ma)



**AUDIO CONTROL HYBRID (6 of 6)**

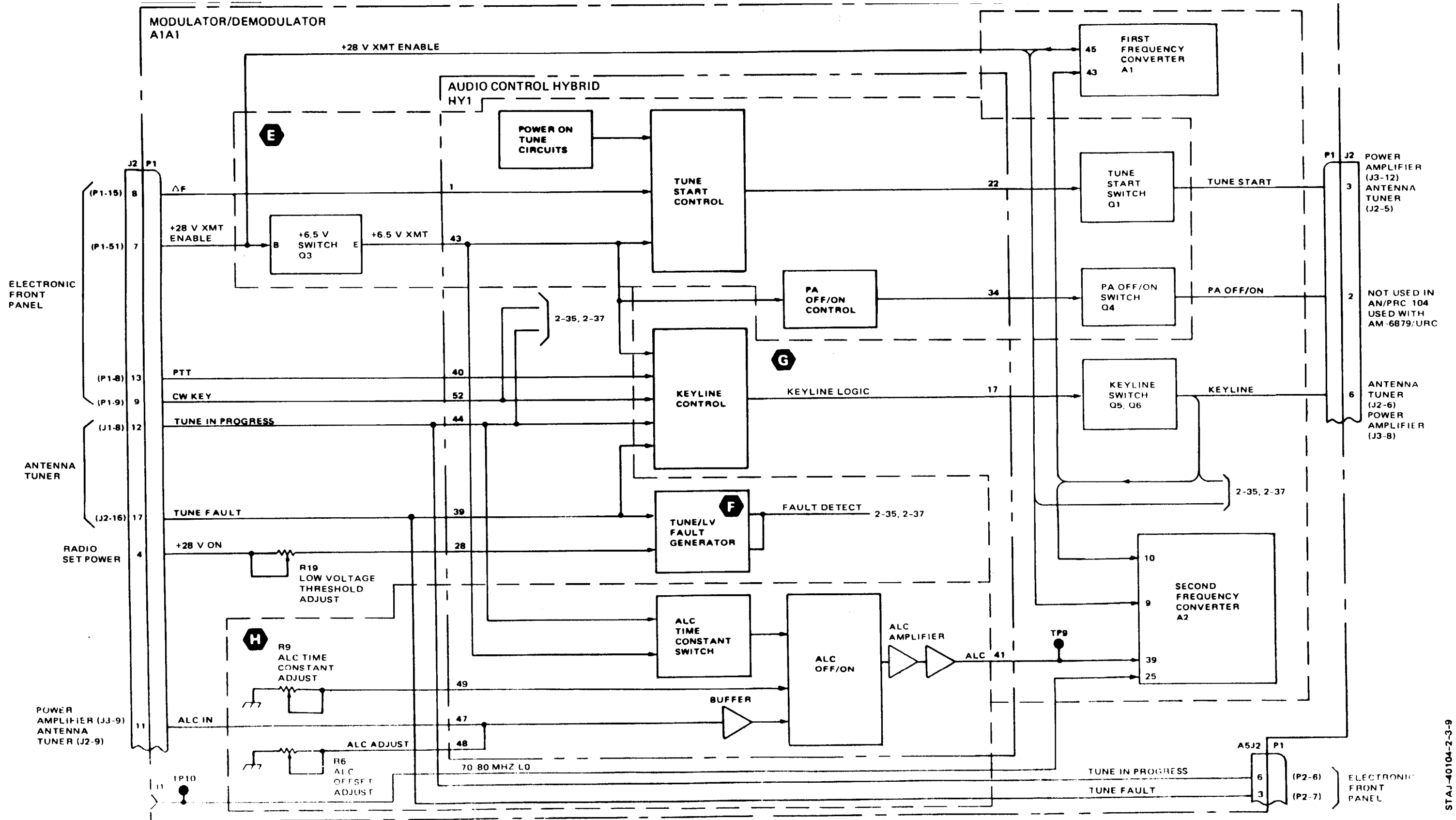

Figure 2-15. Audio Control Hybrid (Sheet 3)

STAJ-40104-2-3-9

**AUTOMATIC LEVEL CONTROL (1 of 2), fig 2-16**

**A** ALC FEEDBACK — The ALC in signal is routed from both the power amplifier and antenna tuner. The power amplifier samples the VFWD from the harmonic filter and compares it against a +14.5 V reference, PA V reference. The +14.5 V corresponds to a 20-watt radio output. When the VFWD exceeds the +14.5 V reference, the ALC in voltage rises. The audio control hybrid reduces the output of the second frequency converter at a rate of 8 dB/V, which corresponds to more than a 40 dB reduction of the second frequency converter's output power. The antenna tuner samples the radio set output, xmt rf, in the tune mode (via the rf sensor bridge) and compares it against a +2.74 V reference AT V reference. The +2.74 V indicates a 2-watt radio output from the rf sensor bridge. The audio control hybrid reduces the gain as above.

**B** ENHANCED ALC FEEDBACK — In ECCM transmit operations, the ALC generated by the audio control hybrid is sampled by a multiplexer. The ALC sample is transferred to the EFP as ALC read data. The ALC logic adjusts the ALC data to conform with ECCM operation and routes it to the multiplexer as ALC write data. When open (op) loop is set active to the multiplexer and the +12.5 V transmit (xmt) signal is present, the ALC write data signal is transferred through the multiplexer to the second frequency converter as ALC out.

**AUTOMATIC LEVEL CONTROL (2 of 2)**

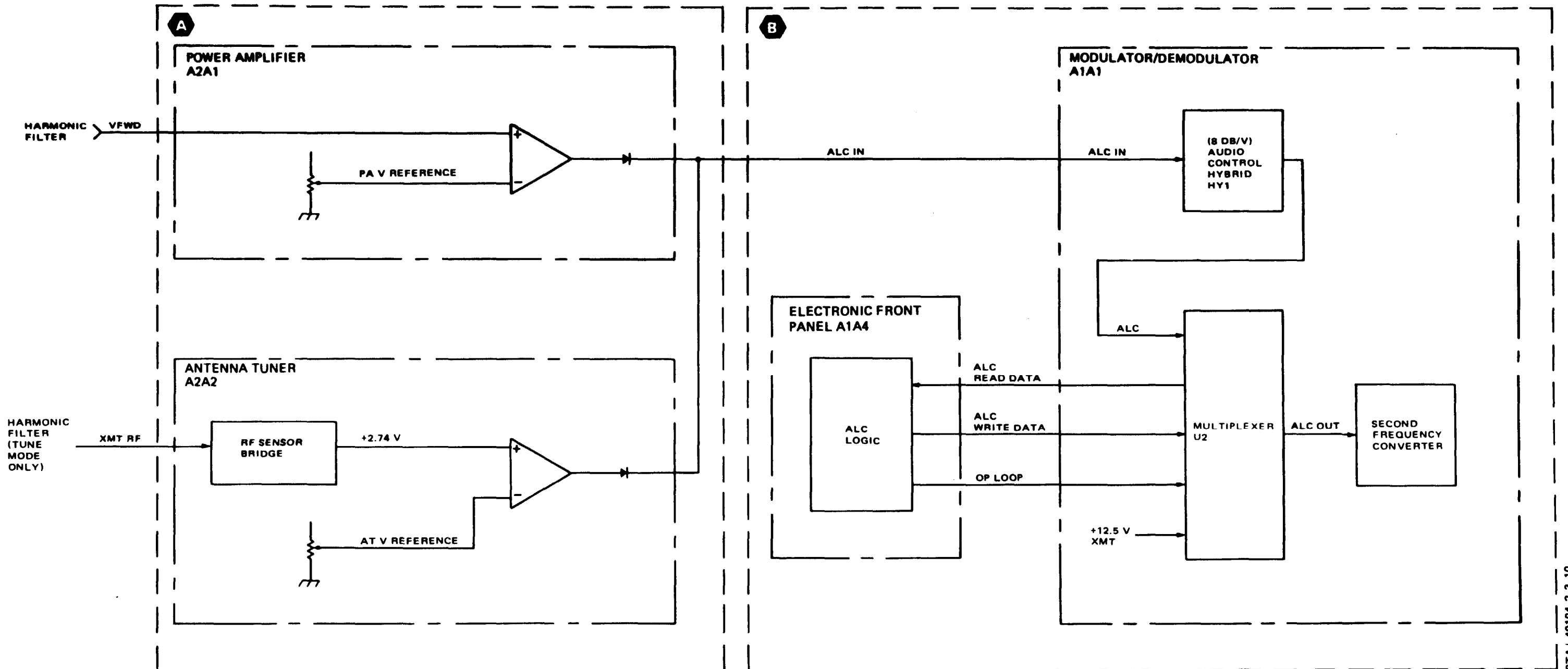

STAJ-40104-2-3-10

Figure 2-16. Automatic Level Control

**FREQUENCY CONVERTERS (1 of 6), fig 2-17, sh 1**

**A B** **THIRD FREQUENCY CONVERTER A3** — In transmit operation, relays K1 and K2 are energized by the +28 V xmt enable and keyline ground signals. This permits xmt audio to be mixed with 5-MHz LO (amplified by AR3) at mixer U2 via the energized contacts (3-2) of K2. The 5 MHz mixing product goes to sideband filter FL2 via the energized contacts (7-8) of relay K2 and contacts (7-8) of relay K1. The energized contacts (2-3) of relay K1 also route +12 V xmt into the first frequency converter. The +12 V xmt in signal also turns switch Q7 on, which causes +6.5 V xmt to be applied to second frequency converter A2 and audio control hybrid HY1. In receive operation, the relays are not energized so the 5 MHz goes through amplifiers AR1 and AR2 and +12.5 V is applied to Zener diode VR1 (which breaks down at +6.5 V). The +6 V output signal is applied to the second frequency converter. The gain of 5 MHz is controlled at AR1 by the AGC voltage from multiplexer U2. This AGC voltage is also applied to the second frequency converter via FH Q2 as AGC in; FET Q2 conducts when the +12 V xmt is absent at the gate (G). The AGC generator, in turn, is controlled by the AGC receive audio signal from the audio control hybrid. A portion of the AGC receive audio

becomes the to vol control signal, which is fed back to the audio control hybrid to control the output of the receive audio amplifier within the audio control hybrid. In data mode, a 100-microfarad capacitor is switched out, which shortens the time constant on the AGC generator output. Finally, 5 MHz mixes with 5 MHz LO, amplified by amplifier Q1, to create the audio frequency and upper sideband mixing product at mixer U2.

**A B C** **ENHANCED AGC/ALC FEEDBACK** — In ECCM receive operation, the AGC produced by the AGC generator is sampled by a multiplexer. The AGC sample is transferred to the EFP as AGC/ALC read data. Within the EFP, the AGC is adjusted to conform with ECCM operation and routed to the multiplexer as AGC/ALC write data. When op loop is set active to the multiplexer and the +12 V xmt signal is not active, the AGC/ALC write data is transferred through the multiplexer to the third frequency converter and FET Q2.

**B** **SIDEBAND FILTER FL2** — This crystal filter functions identically in receive and transmit operation. The filter rejects frequencies other than 4.99945 to 4.997 MHz.

**FREQUENCY CONVERTERS (2 of 6)**

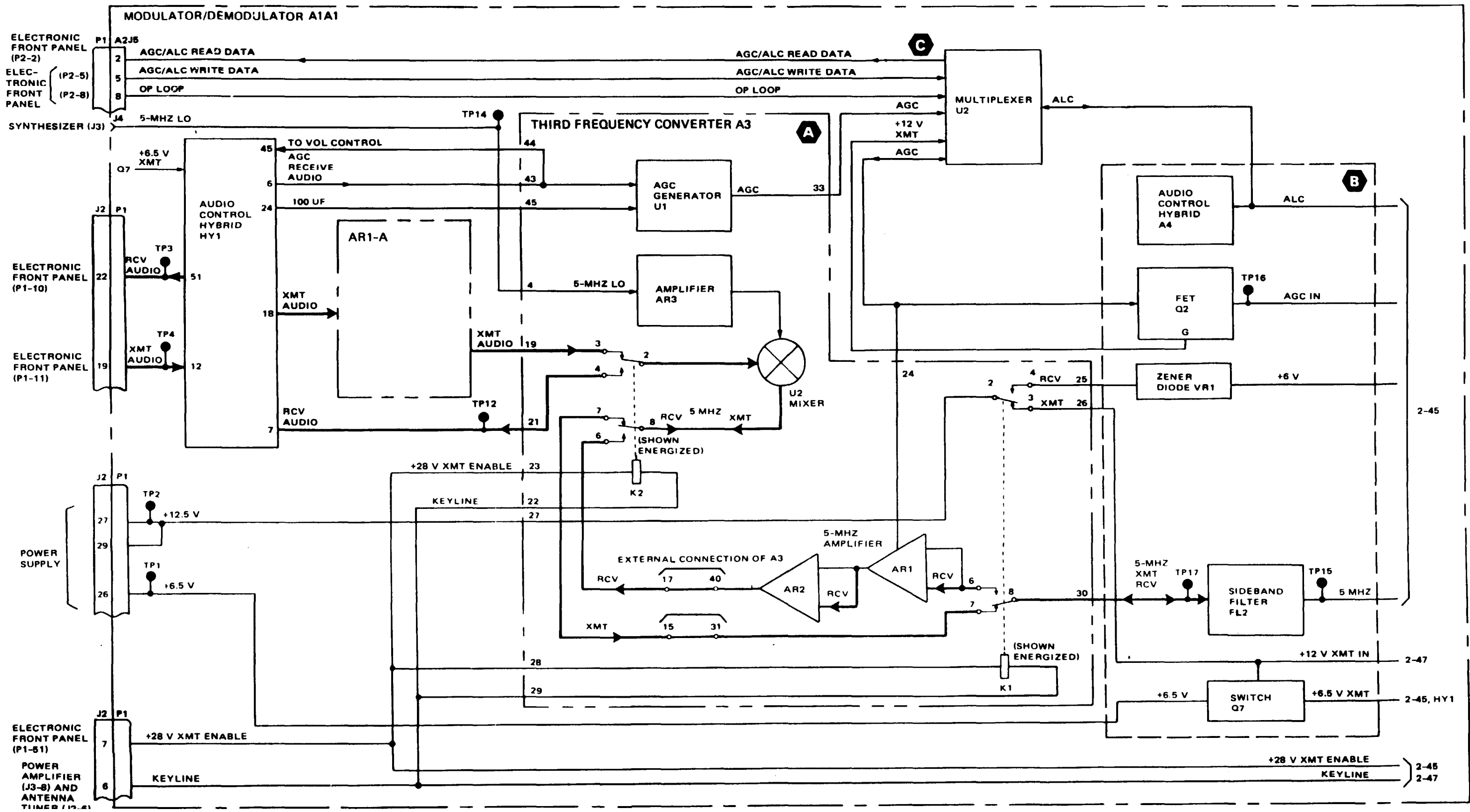

Figure 2-17. Frequency Converters (Sheet 1)

STAJ-40104-2-3-11

**FREQUENCY CONVERTERS (3 of 6), fig 2-17, sh 2**

**D** **SECOND FREQUENCY CONVERTER** — In transmit operation, relay K1 is energized by the +28 V xmt enable and keyline signals. The 5 MHz signal goes through isolation transformer T1 and to amplifier U2; the level (amplitude) of the entire modulator/demodulator transmit output is controlled at this amplifier by the ALC signal from audio control hybrid HY1 and by the presence of +6.5 V xmt. The 5-MHz xmt is applied to mixer U4 where it mixes with the 70-/80-MHz LO signal. (70-/80-MHz LO has been previously amplified at amplifier U1.) This results in a mixing product 70 MHz  $\pm$ 5 MHz or 80 MHz  $\pm$ 5 MHz. (In either case, only the 75 MHz product is passed by bandpass filter FL1.) The 75-MHz mixing product is routed through energized contacts 8-7 of relay K1, through amplifier Q1, T3, and back through energized contacts 3-2. The 75-MHz

mixing product is routed to bandpass filter FL1. In receive mode, the 75-MHz mixing product passes through deenergized contacts (2-4-7) of relay K1, through amplifier Q1, T3, and back through contacts 3-6-8. The 75-MHz mixing product mixes with 70-/80-MHz LO at mixer U4. The 5-MHz product (5-MHz rev), goes through amplifier Q2, T4 and isolation transformer T5. FET Q3 and amplifier U3 control the gain of the 5-MHz mixing product via signals AGC In and +6 V. Finally 5 MHz is routed to pin 29 to sideband filter FL2 (page 2-43).

**E** **BANDPASS FILTER FL1** — The filter functions identically in receive and transmit operation. The filter rejects frequencies other than 75 MHz  $\pm$ 15 kHz.

FREQUENCY CONVERTERS (4 of 6)

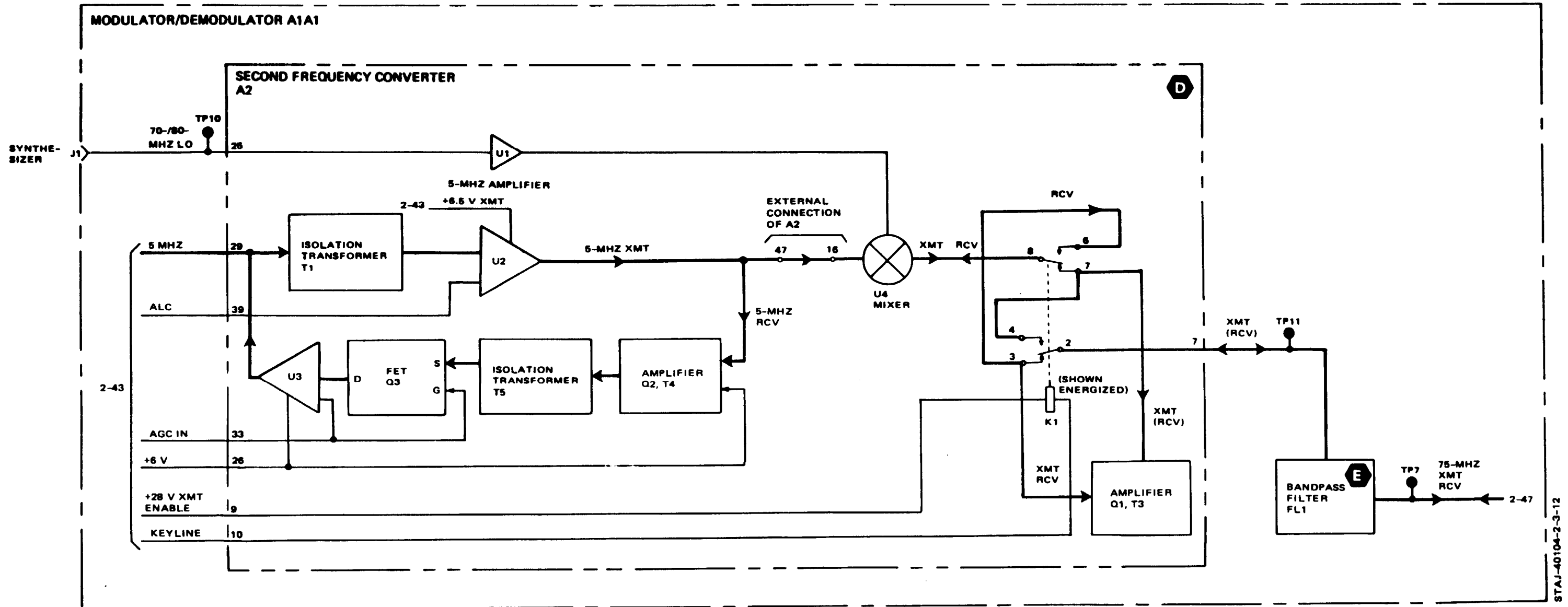

Figure 2-17. Frequency Converters (Sheet 2)

**FREQUENCY CONVERTERS (5 of 6), fig 2-17, sh 3**

**F** **FIRST FREQUENCY CONVERTER** — In transmit operation, relay K1 is energized by the +28 V xmt enable and keyline ground signals. The xmt rcv goes to mixer U2 where it mixes with 77-105 MHz LO (77-1 05 MHz LO has been previously amplified at amplifier U1 after passing through the rf blanking switch). This results in the rf mixing product (2-30 MHz and 152-180 MHz). The rf mixing product is routed through energized contacts 8 and 7 of relay K1 to the 2-30 MHz amplifier Q1 -Q3, T1 -T6 where it is boosted to 0.25 watt. The frequency component above 30 MHz is not amplified. The +12 V xmt in from the third frequency converter powers this amplifier. The rf mixing product goes through energized contacts 3 and 2 of relay K1 to output jack J3. In receive operation, the 2-30 MHz rf is routed through contacts 2, 4, 6, and 8 of relay K1 to mixer U2. The 2-30 MHz rf mixes with 77-105 MHz LO to produce a 75-MHz mixing product.

**G** **RF BLANKING SWITCH** - The rf blanking switch is used to disable transmit and receive radio set operation. In receive operation, when rf blank is set active by the EFP, the 77-105 MHz LO signal is not routed to mixer U2. With the 77-105 MHz LO signal not present at mixer U2, the xmt rcv 75 MHz signal is not produced and receive operation is disabled. In transmit operation, when rf blank is set active by the EFP, the 77-105 MHz LO signal is not routed to mixer U2. With the 77-105 MHz LO signal not present, the transmit frequency, xmt rcv 75 MHz, is not mixed and transmit operation is disabled. Normal transmit and receive operation resumes when rf blank becomes inactive.



**FREQUENCY CONVERTERS (6 of 6)**

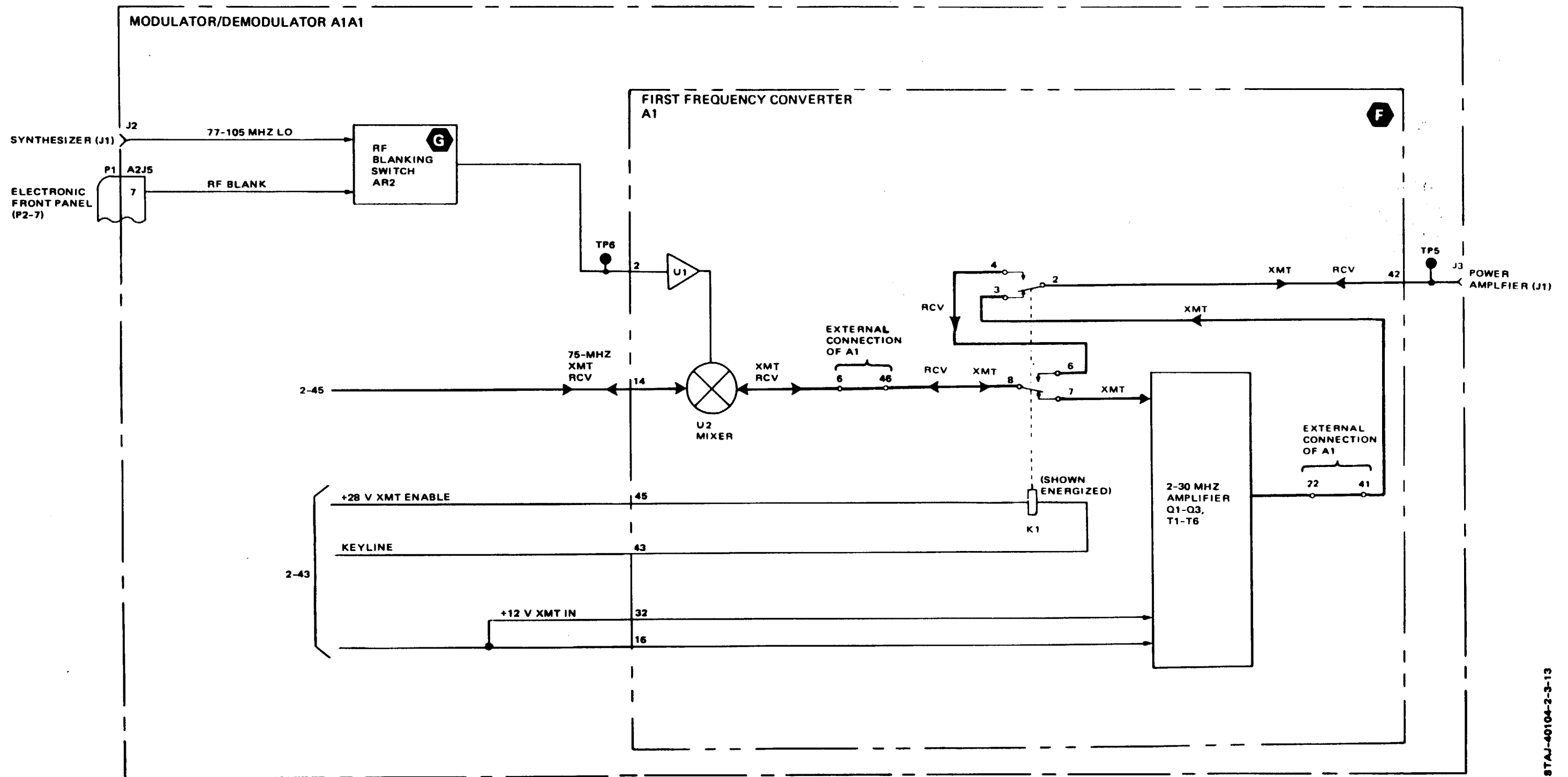

8TAJ-40104-2-3-13

Figure 2-17. Frequency Converters (Sheet 3)

**HARMONIC FILTER (1 of 2), fig 2-18**

**GENERAL TRANSMIT OPERATION** — The harmonic filter suppresses transmitter harmonics and noise levels outside of the selected frequency band.

**A BANDPASS FILTER SELECTION** — The selection of one of six bandpass filters, FL1 thru FL6, is controlled by the filter select band signals from the control panel. The filter select signal (grid) is applied directly to the relays of the selected bandpass filter to provide a return path for the relay solenoid. The following chart lists the filter select band signal and the filter selected by the signal. For example, the 2-3 MHz band signal selects FL6 between 2000 kHz and 2999 kHz.

Filter Select Band Signal	Selected Filter
20-30 MHz band	FL1
12-20 MHz band	FL2
8-12 MHz band	FL3
5-8 MHz band	FL4
3-5 MHz band	FL5
2-3 MHz band	FL6

**B TRANSMIT/RECEIVE RF PROCESSING** — Xmt rf from the power amplifier is routed through the energized contacts of relay K1 of the selected filter via the filter network and through the rf low pass filter and the rf detector to the antenna tuner. The rf low pass filter is an L-C filter network that improves the high frequency suppression (above 30 MHz) of the selected bandpass filter. The rf detector generates dc voltages proportional to the forward power (VFWD) and the reflected power (VREFL).

**B RECEIVE OPERATION** — The receive operation is performed in the reverse direction. Rcv rf operation from the antenna tuner passes through the rf detector and rf low pass filter, and through the energized contacts of the selected filter to the power amplifier.

**HARMONIC FILTER (2 of 2)**

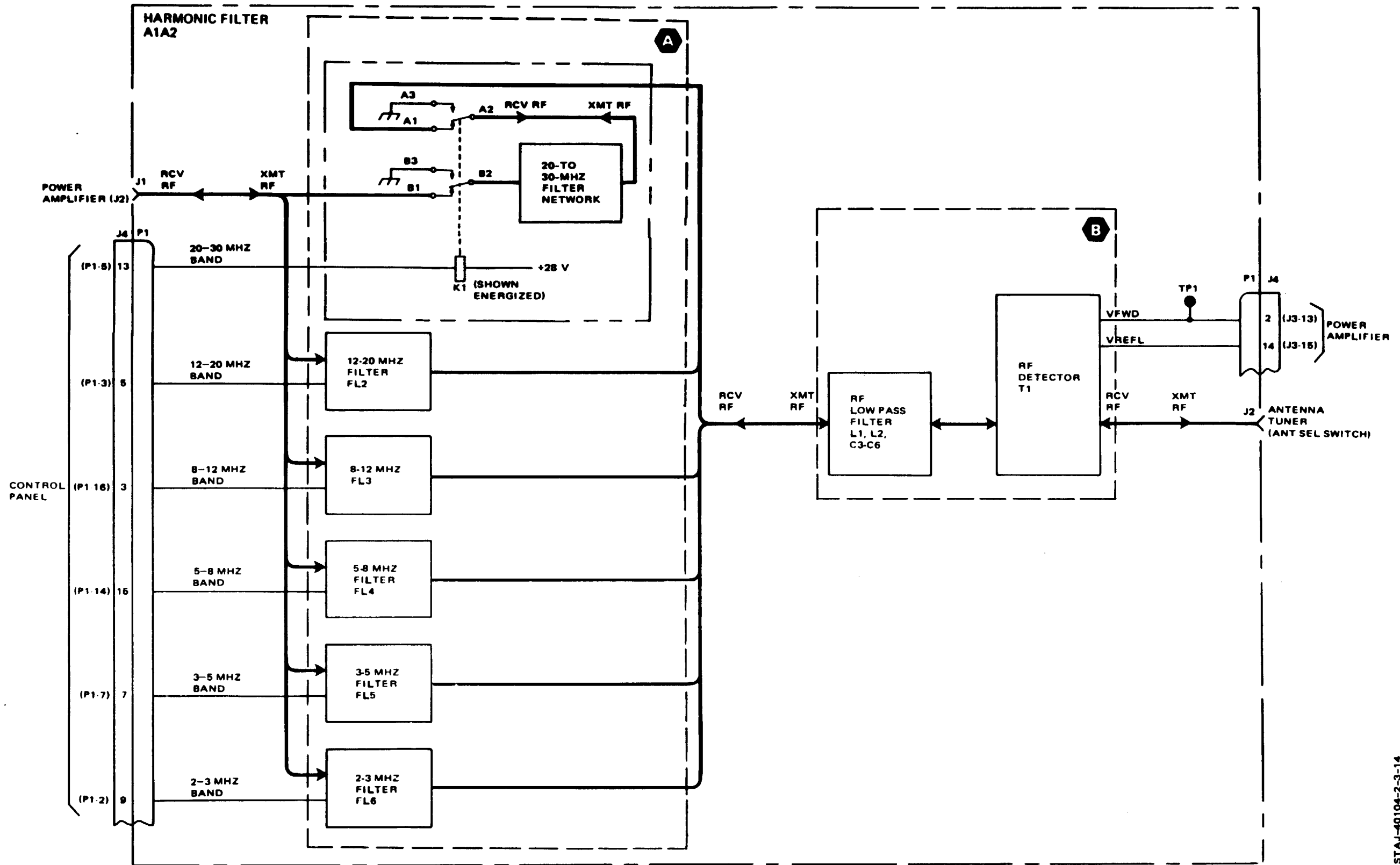

Figure 2-18. Harmonic Filter

STAJ-40104-2-3-14

**POWER SUPPLY (1 of 2), fig 2-19**

**GENERAL** — This module *converts* +28 V from the battery (via the control panel) to +6.5 V and +12.5 V for use by the other modules.

**A** **DOWN SWITCHING** — The actual conversion from +28 V to +12.5 V or +6.5 V is performed by down switchers U3 and U4 shown in the detail on page 2-51. A transistor switch (Q) is driven on and off at a switching frequency of approximately 77 kHz. When the switch (Q) is closed, current flows through the inductor (L) and charges the capacitor (C). When the switch opens, the energy stored in the inductor (L) is transferred into the capacitor (C) via the diode (D). The voltage on the capacitor (C) is determined by the ratio of closed to open time of the switch (Q). The switch (Q) and diode (D) are integrated parts of switching regulators U3 or U4. The other elements are discrete.

**B** **SWITCHING FREQUENCY** — The voltage feedback for the +12.5 V or +6.5 V output modulates the on/off periods of timers U1 and U2, respectively. That is, if the load is small, the capacitor charges easily and cuts the slave timer off. Conversely, if the load is large, the slave timers U1 and U2 stay on (low) for a longer interval.

**C** **OVERLOAD LATCH** — Overload latch circuit Q1, Q2 shuts the slave timers U1 and U2 off, if an abnormally large load appears. The large current flow through R3 turns on Q1, which then turns on Q2, causing Q1 to latch on. A large voltage appears on the voltage feedback line and turns U1 and U2 off. The power supply remains off until the +28 V input is removed momentarily by switching the radio off and then back on.

POWER SUPPLY (2 of 2)

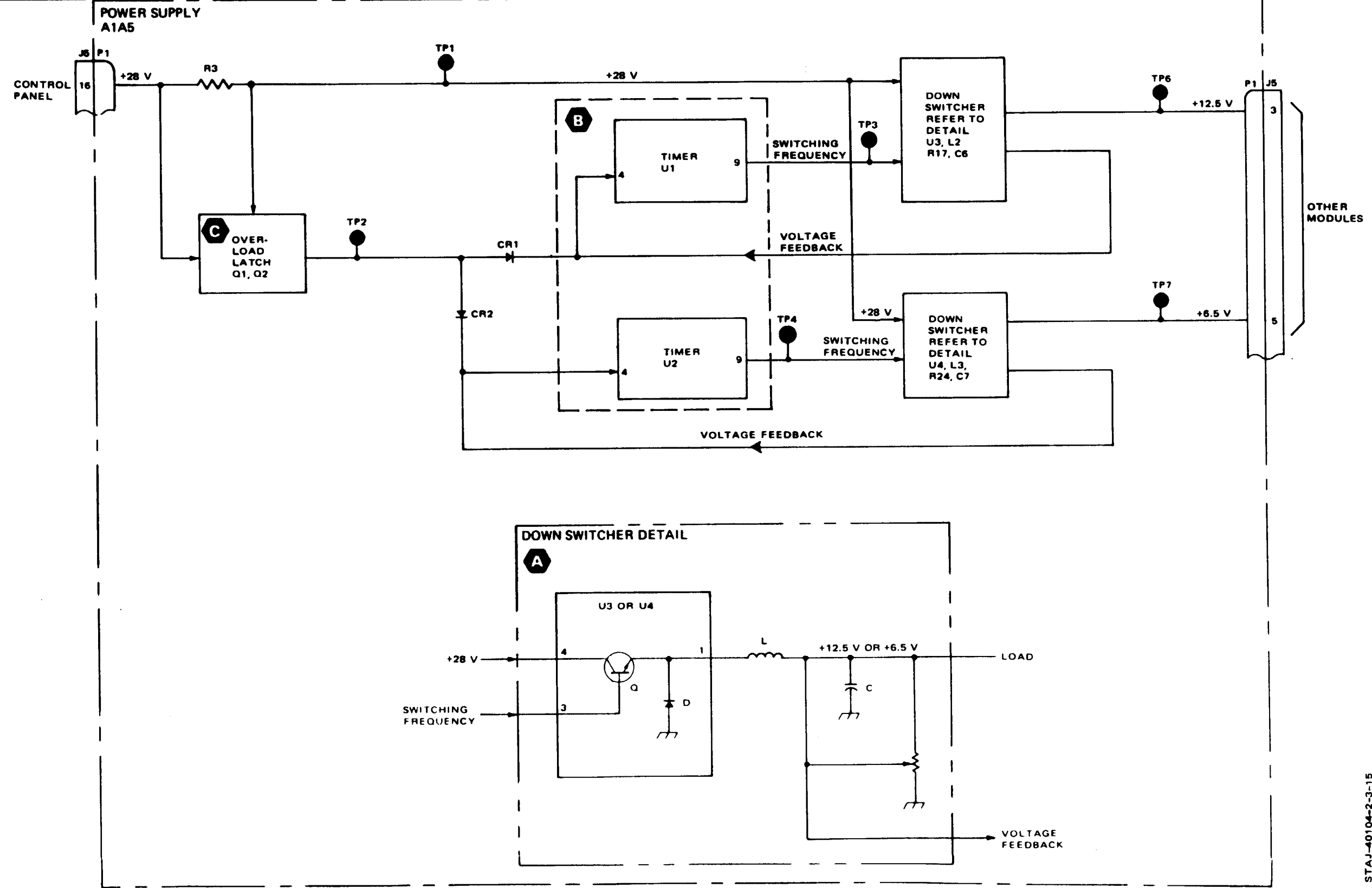

Figure 2-19. Power Supply

STAJ-40104-2-3-15

BLANK  
INTENTIONALLY

Section IV POWER DISTRIBUTION

	Page
General .....	2-53
Power Distribution Description .....	2-54

**GENERAL**

This section gives a general description of the radio set power distribution system. A power distribution diagram is provided to supplement the description.

**POWER DISTRIBUTION DESCRIPTION, fig 2-20**

The +28 V battery (power input) from the battery pack is routed through the amplifier/coupler to the power amplifier module and a fuse and to the EFP module, located in the RT unit.

**A** In the EFP, the +28 V battery signal is routed to a MOSFET controlled by the VOLUME OFF/MAX FET switch where it is redesignated as +28 V on. The +28 V on signal is route to the following modules: power amplifier (amplifier/coupler unit), modulator/demodulator, synthesizer, harmonic filter, and power supply.

**B** The power supply converts +28 V to +6.5 V and +12.5 V. The +12.5 V signal is routed to the EFP, synthesizer, and modulator/demodulator. The +6.5 V signal is routed to the synthesizer, modulator/demodulator, power amplifier, EFP, and antenna tuner. The synthesizer filters out any ripple in the +6.5 V signal by converting +6.5 V to +6 V. The +6 V signal is routed to the modulator/demodulator.

**C** The power amplifier supplies +16 V regulated to the relays of the antenna tuner during the tune mode. This voltage varies from +14 ±2 V, depending on the ambient temperature.

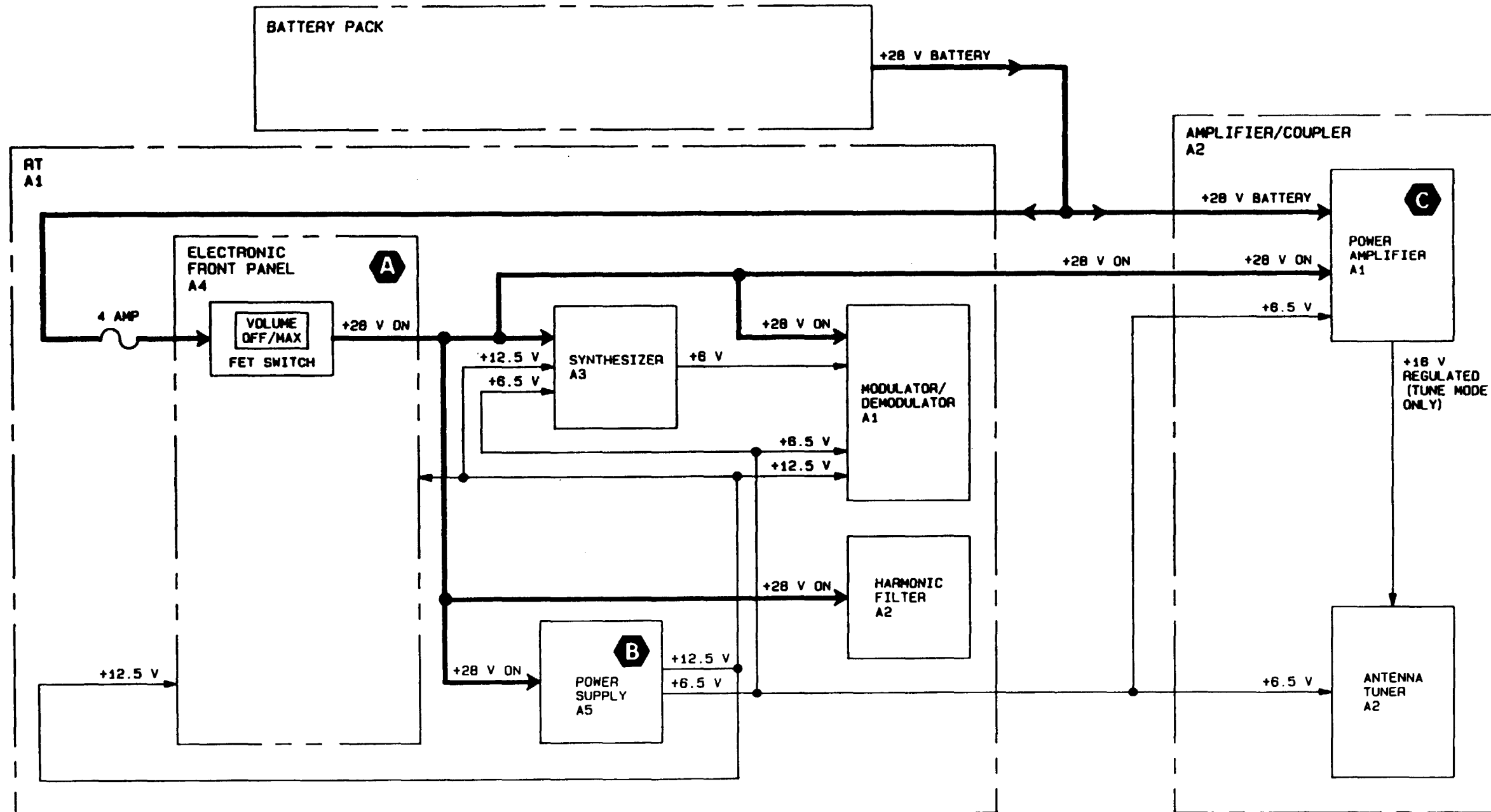

Figure 2-20. Power Distribution Description



## CHAPTER 3 GENERAL MAINTENANCE

### Section I. CIRCUIT CARD ASSEMBLY REPAIR PROCEDURES (MARINE CORPS ONLY)

	P a g e
General .....	3-1
Circuit Card Standards.....	3-2
Circuit Card Repair Procedures .....	3-4

**GENERAL**

This section is intended for Marine Corps use only.

This section contains description and definitions of standards to be observed, followed by procedures to be performed for repair of circuit cards and replacement of components. Read the procedures in this section before attempting card repair.

**CIRCUIT CARD STANDARDS (1 of 2)**

**SOLDERING STANDARDS FOR CIRCUIT CARDS**

The following paragraphs contain standards to be observed when soldering circuit cards.

**SOLDERING VOIDS** — A void is an area that is not filled with solder, the extent of which is completely visible. For cards with eyelets or plated-through holes, voids in the circuit side of a solder joint are permissible, provided they are not deeper than one-half of the hole depth and over more than one-quarter of the hole area. If no circuit is connected to the pad on the side of the void, the void may extend over the entire hole area if the outline of the lead is visible. Voids in unsupported holes may extend through the hole, but should not extend over more than one-fifth of the hole area.

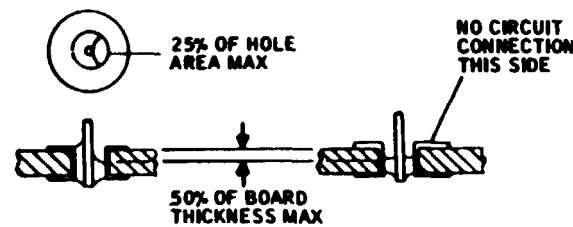

Void Standards

**SOLDERING PINHOLES** - A pinhole is a hole in the surface of the solder that indicates the absence of solder beneath the surface, the extent of which is not visible. Pinholes should not be permitted adjacent to the component lead or wire.

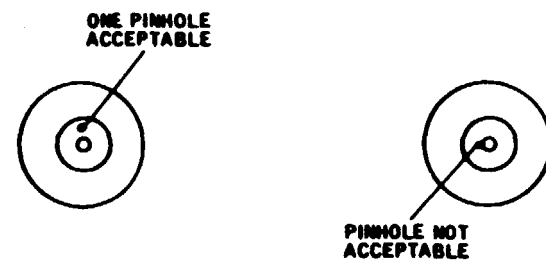

Pinhole Standards

**PAD AREA** - Solder is not required to cover the entire pad area. Voids and pinholes in these areas are acceptable.

**EXCESSIVE SOLDER** — Solder that flows beyond the bend radius of a component lead is not acceptable, except for small diameter components (eg, glass diodes). The maximum solder height, including component lead, on the bottom of the board is 0.062 inch. Solder spikes should not exceed 0.062 inch.

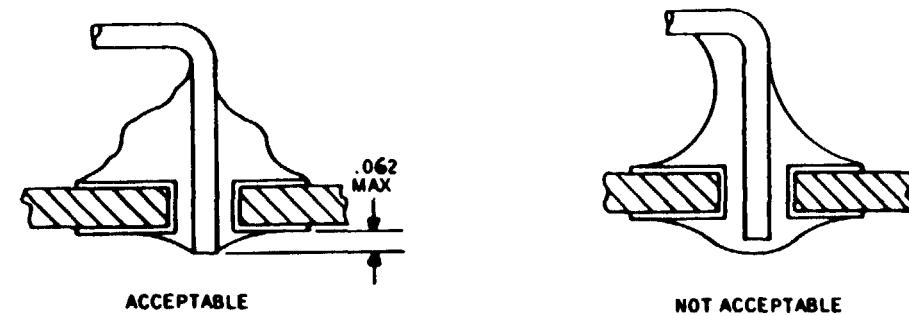

Solder Height Standards

**INSUFFICIENT SOLDER** — Except for permissible voids and pinholes, the solder must fill the hole to the point where the solder covers the entire inner surface of the hole. For eyelet holes or standoff terminals with circuit connections, the solder should flow between the eyelet and the pad for at least four-fifths of the circumference.

**COLD SOLDER JOINTS** — Cold solder joints where the solder balls at the point of contact with a pad or lead are not acceptable.

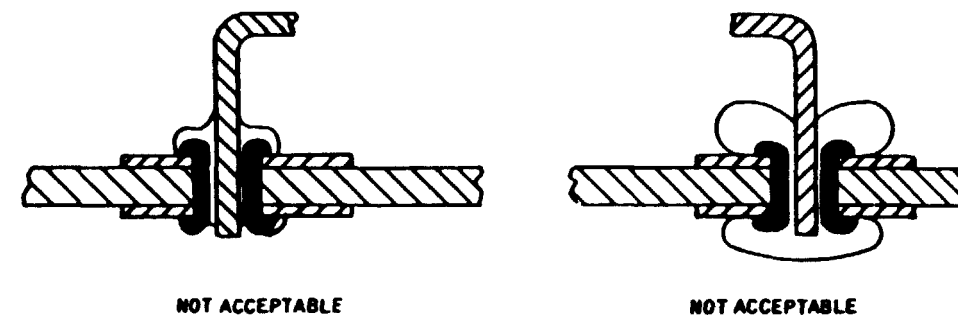

Cold Solder Joints (Not Acceptable)

**CIRCUIT CARD STANDARDS (2 of 2)**

**PREFERRED SOLDER CONNECTIONS** — All components may be soldered by either flow soldering or hand soldering. The completed joint must have a clear, smooth appearance, which indicates proper soldering. Examples of preferred solder connections are shown below.

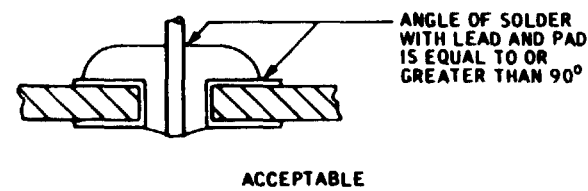
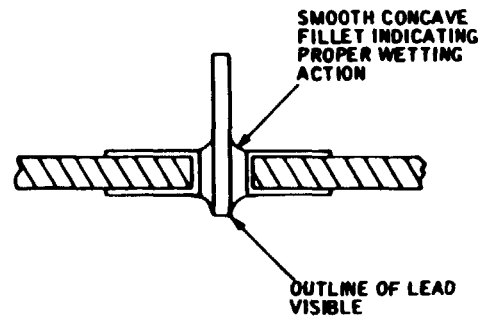

PLATED-THROUGH HOLE

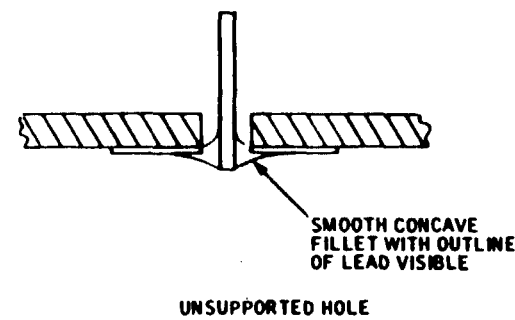
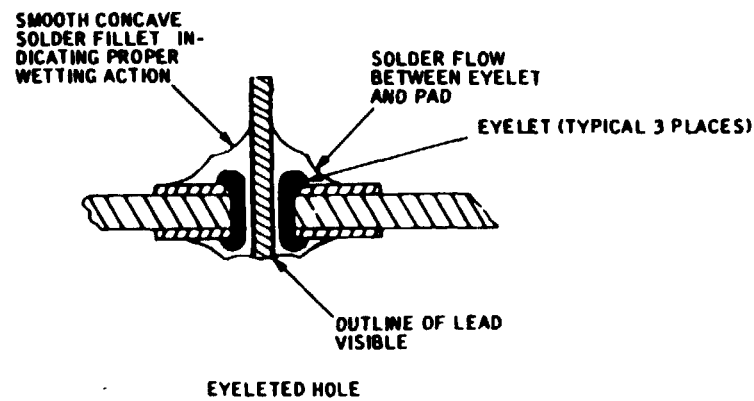

Preferred Solder Connections

**CIRCUIT CARD BASE MATERIAL STANDARDS**

Cracks, chips, or gouges in the base material should not exceed the following:

1. Cracks or chips should not exceed back from the edge of the hole more than 0.040 inch.
2. Cracks, chips, and gouges at the edge of the board should not exceed one-third of the board thickness or extend back more than 0.12 inch from the edge.
3. Cracks, chips, and gouges are not acceptable on the contact strip edge of the board.
4. Cracks or chips should not extend from one conductor to another conductor.
5. Delamination of the base material is not acceptable.

**CIRCUIT CARD ETCH STANDARDS**

Circuit card etch standards are as follows

1. Cracks, pits, or voids in the contact strip area are not acceptable.
2. Scratches that expose the copper are not acceptable.
3. Cracks, pits, or voids in any etch that reduce the conductor by more than 20 percent are not acceptable. No defect should reduce the conductor to less than 0.010 Inch.
4. Lifting of a conductor above the surface of the board is not acceptable.
5. Reduction in the area of any pad in excess of 25 percent is not acceptable. Crack, pits, or voids should not extend to a plated-through hole.

**STORAGE AND HANDLING OF CIRCUIT CARDS**

When stored, circuit cards should be wrapped individually in polyethylene bags, or equivalent, or stacked in storage pans. Other objects should not be placed in the storage pans with circuit cards. Avoid touching the circuit card surface with bare hands or fingers. Handle the circuit card by its edges.

**CIRCUIT CARD REPAIR PROCEDURES (1 of 9)**

**WARNING**

Vapors emitted during certain circuit card repair procedures may be irritating to personnel. Always perform circuit card repair in well-ventilated area.

**CAUTION**

The circuit cards contain parts sensitive to electrostatic discharge (ESD). Use ESD precautionary procedures when handling, removing, or replacing a circuit card.

The repair of circuit cards requires proper tools and careful work habits. Excessive heat when soldering, or undue force applied to components or the circuit card, can seriously damage the assembly. The following precautions should be observed:

1. Never try to save a component part at the possible expense of damaging a circuit card. Most component parts can be clipped from the circuit card. When clipping the defective part, be careful to protect the printed circuit conductor (etch) and other component parts.
2. A vacuum soldering unit should be used, if available to remove the leads of a clipped part. The technical manual for the vacuum desoldering unit contains operating procedures for the unit. The vacuum desoldering unit operates as follows: a high vacuum flows through a hole in the unit, across the pads and around the leads to remove the solder and cool down these areas to prevent reseating of the lead. At the same time, the temperature-controlled resoldering tip, which initially provided the heat to melt the solder, is cooled rapidly by the airflow to prevent further heat from being applied to the workplace. Once the airflow is stopped, the tip heats up rapidly for continued vacuum desoldering. The coaxial, in-line design of the handpiece allows molten solder and clipped leads to be drawn into the heat-resistant chamber where solder is solidified.
3. Exercise care when using a soldering iron to remove the leads of a clipped part, to connect a new part, or to service the circuit card itself. Circuit cards are easily damaged by heat. Prolonged application of heat will destroy the adhesive quality of the bonding agent that holds the printed etch to the circuit card. Use the recommended soldering iron, or equivalent.
4. Use solder sparingly. Excess solder should be removed with the recommended solder-removing tool, or equivalent.
5. Clean and tin the leads of a component before soldering the component to the board.
6. Check the work. Be careful the solder joint is firm and clean.

**CIRCUIT CARD REPAIR TOOLS AND MATERIALS**

For repair of the circuit cards, the recommended tool and materials are listed in the following tables.

Tool	Manufacturer	Part Number
Bench Repair Center	Pace inc.	PRC-350C
Tool Kit, Electronic	...	TK-105/G
Maintenance Kit, Printed Circuit	...	MK-984/A
Clamps, Small	...	...
Coining Tool	Erem	5174
Oven capable of maintaining 150 ±10°F	...	...
Parallel gap welding machine: Power Supply Welding Head	... ...	MCW 550 VTA66

Material	Manufacturer	Type
Acetone Solvent (acetone)	...	...
Epoxy Compound (Epon packaged in a plastic syringe, DTA catalyst in a glass vial)	Frey Engineering	MIL-I-16923
Epoxy Adhesive	Narmco	3135A and B Kit
Epoxy Adhesive Kit, flexible, frozen pre-mix (Narmco Adhesive Kit)	Narmco	3135
Epoxy Adhesive Kit, flexible, 18 gram (Narmco Adhesive Kit)	Narmco	3135-MRO 40-0965
Epoxy Adhesive Kit, flexible, 1 pint (Narmco Adhesive Kit)	Narmco	3135-MRO 40-0962
Glass Beads, 0.003-inch diameter	Superbrite	...
Hook-up Wire and Cable, 26 gage, insulated electrical (copper jumper wire)	...	4297780-49, LW-C-26-1-J-9

**CIRCUIT CARD REPAIR PROCEDURES (2 of 9)**

Material	Manufacturer	Type
Isopropyl Alcohol	...	...
Masking Tape	...	...
Polyurethane Conformal Coating Compound	Conap, Inc.	MIL-I-46058, Type UR
Sandpaper, 80 to 180 grit	...	...
Soldering Flux	Kester	197
Solder, Rosin-cored, 1/32 inch	Kester	44
Solder-wick	Solder Removal Co.	-3-500
Solvent	Conap, Inc.	MIL-I-46058, Type UR
Solvent, TMC (Freon TMC solvent)	Freon	MRO 55
Thermally Conductive Adhesive	Wakefield	Delta Bond 152
Tin-coated Wire, 34-gage, uninsulated, electrical	...	4297869-5
Toluene Solvent (Toluene)	...	...

**ETCH REPAIR**

The solder-plated copper or gold-plated copper conductors (etch) bonded to the surface of the circuit cards can be damaged when mishandled or when a component failure causes current flow that exceeds the current-carrying limits of the etch. Certain types of damage to the etch can be repaired by using the appropriate repair techniques. Scratches or gouges on the etch can be repaired by soldering. Soldering is also used to repair voids or pinholes in the etch. Breaks or cuts in the etch can be repaired by bridging the defect with a new section of etch. Lifted, raised, or unbended etch can be repaired by pressing the etch against the card surface and encapsulating the defect with epoxy adhesive. Damaged plated-through holes or eyelets are repaired by inserting and soldering an eyelet. To repair damaged etch, perform the procedures in the following paragraphs that apply to the type of damage to be repaired.

**REPAIR OF SCRATCHED, GOUGED, VOIDED, OR PINHOLED ETCH** - Scratched, gouged, voided, or pinholed etch faults can be repaired by performing the following steps

1. With an X-acto knife, scrape polyurethane coating from area of circuit card to be repaired. Be careful not to cause further damage to etch.
2. Flatten any burrs that exist on defective area of etch by using back of recommended diagonal cutting pliers, or equivalent.
3. Use brush to apply soldering flux to etch where defect exists.
4. Use soldering iron to apply solder to defect. Use solder sparingly.
5. Inspect the repair to be certain damaged area has been bridged by solder.
6. Encapsulate worked area by method described in Repair of Polyurethane Conformal Coating (page 3-8).

**REPAIR OF BROKEN GOLD-PLATED COPPER ETCH** — Broken or cut gold-plated copper etch can be repaired by performing the following steps

1. With an X-acto knife, scrape polyurethane coating from area of circuit card to be repaired. Be careful not to cause further damage to etch.
2. Cut out a section approximately 1/2 inch longer than area to be repaired from a strip of gold-plated copper ribbon (etch material).
3. Tin new piece of etch material. Use solder sparingly.
4. Position new etch material over damaged area so it overlaps by 1/8 inch and hold it in place with orange stick.
5. Touch soldering iron to one end of new etch material until solder flows to damaged etch at that end.
6. Use orange stick to smooth out new etch material, work toward unsoldered end. Hold in place with orange stick, cut off surplus, and allow approximately 1/8 inch for overlap.
7. Touch soldering iron to free end of new etch material until solder flows to damaged etch at that end.

**WARNING**

Isopropyl alcohol is flammable. Keep away from heat and open flame. Vapors may be harmful. Use with adequate ventilation. Avoid prolonged or repeated breathing of vapor. Do not take internally.

8. Remove excess soldering flux with isopropyl alcohol.
9. Apply masking tape around repaired area. Allow approximately 1/16-inch gap between circuit and tape on both sides and 1/8-inch gap at ends.

**WARNING**

Adhesives are irritating to the skin and eyes upon contact, and may emit harmful vapor. Use only with adequate ventilation. Avoid all skin and eye contact. Use protective clothing such as rubber gloves, apron and eye protection. Wash off immediately any accidentally contaminated skin area. Hand-washing facilities and eye-wash fountain should be provided. Do not take internally.

10. Mix small quantity of epoxy adhesive in equal parts on smooth piece of glass or hard plastic; mix 2 components thoroughly.
11. Seal repaired area by neatly applying thin, smooth bead of mixed adhesive over and around edges of circuit.
12. Allow adhesive to set 1 hour at room temperature.
13. Remove masking tape and remove surplus adhesive by scraping lightly.

**WARNING**

Handling hot items presents a serious injury potential. Heat-protective gloves are required.

14. Cure repair in oven 1 hour at 150 ±10°F or allow to stand at room temperature 24 hours.

**CIRCUIT CARD REPAIR PROCEDURES (3 of 9)**

**WARNING**

Polyurethane contains flammable solvents and toxic diisocyanates. Keep away from heat and open flame. Vapors or mists are harmful. Complete body protection, including entire head, is required to prevent skin or eye irritation from contact with the paint or its vapors or mists. Respirator protection is required, usually an air-supplied hood, during mixing, curing, and application. Use this paint only with the protection requirements as specified above. Suitable flushing facilities must be provided for immediate clean water flushing or any accidental skin or eye contact. Do not take internally.

15. Encapsulate worked area with polyurethane coating by method described in Repair of Polyurethane Conformal Coating (page 3-8).

REPAIR OF RAISED OR UNBONDED GOLD-PLATED COPPER ETCH — Raised or unbonded gold-plated copper etch can be repaired by performing the following steps:

1. Determine hole diameter required for new eyelet and select eyelet of similar size.

**WARNING**

Drilling operations create metal chips which may enter the eyes and cause serious injury. Eye protection is required.

2. if hole is plated-through, drill hole to accommodate new eyelet. Be careful not to raise etch while drilling if hole has an eyelet, remove defective eyelet.
3. Use eyelet press and dies to insert and form new eyelet; allow approximately 0.01 inch of etch to extend beyond eyelet rim. Allow clearance under both of formed heads so solder flow under and around formed heads will not be impaired.
4. insert round toothpick, or equivalent, in eyelet hole to prevent solder from entering hole.
5. Apply soldering flux with brush to eyelet and surrounding etch.
6. Use soldering iron to apply solder to eyelet and to surrounding etch on both sides of circuit card.

**WARNING**

Isopropyl alcohol is flammable. Keep away from heat and open flame. Vapors may be harmful. Use with adequate ventilation. Avoid prolonged or repeated breathing of vapor. Do not take internally.

7. Remove soldering flux and clean circuit card with isopropyl alcohol.

REPLACEMENT OF LIFTED PAD

Lifted pads (circular etch surrounding either eyelets or plated-through holes that have raised from the board) can be replaced by performing the following steps:

1. Remove lifted pad. if hole has an eyelet remove eyelet first.

**WARNING**

Toluene is flammable. Keep away from heat and open flame. Vapors may be harmful. Use only with adequate ventilation. Avoid prolonged or repeated breathing of vapor. Avoid contact with skin and eyes. Do not take internally. Comply with air pollution control rules concerning photochemically reactive solvents.

2. Clean area from which defective pad was removed with clean cloth moistened with toluene.

**WARNING**

Adhesives are irritating to the skin and eyes upon contact, and may emit harmful vapor. Use only with adequate ventilation. Avoid all skin and eye contact. Use protective clothing such as rubber gloves, apron, and eye protection. Wash off immediately any accidentally contaminated skin area. Hand-washing facilities and eye-wash fountain should be provided. Do not take internally.

3. Apply thin, smooth coat of clear epoxy adhesive to area from which defective pad was removed.
4. Place new pad, as nearly as possible, in exact position of defective pad. insert round, pointed toothpick in hole to help in alignment. Press pad firmly in place with orange stick while gently removing toothpick from hole.
5. Allow epoxy adhesive to set for 1 hour at room temperature.
6. Carefully remove surplus adhesive by using clean cloth moistened with toluene or other suitable solvent

**WARNING**

Handling hot items presents a serious injury potential. Heat-protective gloves are required.

7. Cure repaired pad in oven 1 hour at 150 ±10°F or let stand at room temperature 24 hours.
8. if repair appears wet and well-bonded, install and solder an eyelet as described in steps 3 thru 7 of Repair of Raised or Unbonded Gold-Plated Copper Etch (page 3-6).

**CIRCUIT CARD REPAIR PROCEDURES (4 of 9)****REMOVAL OF BONDED PARTS**

A part that has been bonded to a circuit card (with an epoxy adhesive or similar compound) can be removed after the leads have been clipped or unsoldered by breaking the defective part or by applying heat to the bonding compound. The method used depends on the type of part and its location. If a defective part cannot be removed by heat, cut or break the part away from the bonding compound. In some cases, the part to be replaced is so closely positioned between other parts that one lead must be cut close to the body of the defective part to permit application of a prying tool. Wherever possible, cut the defective part with diagonal cutting pliers.

**CAUTION**

Never apply excessive pressure against a circuit card.

Regardless of the tool used (round-pointed or spade type), great care must be exercised in its use to prevent the circuit card or other parts from being damaged or broken. Apply the point of the tool against the bonding compound and between the part and the circuit card. Use the tool so that it works away the bonding compound from the part to be broken until enough has been removed for the tool to exert pressure against the part. Keep the leverage surface area of the tool flat against the surface of the circuit card to prevent the tool from gouging or breaking the board.

**REMOVAL OF SOLDERED COMPONENTS HAVING AXIAL LEADS**

Components with axial leads that are soldered in place on the circuit card may be removed by performing the following steps:

1. Use diagonal cutting pliers to cut leads of component part close to component. Carefully straighten end that extends through each hole so that lead may be easily withdrawn.
2. Use vacuum desoldering unit, if available, to remove solder from each lead on component. If vacuum desoldering unit is not available, exert slight pressure and apply tip of soldering iron to tip of lead. Keep soldering iron away from circuit etch. Remove soldering iron immediately and quickly pull lead free. Use solder-removing tool to remove excess solder. Do not force or twist lead to remove it from circuit card.
3. Remove component from circuit card.

**REMOVAL OF SOLDERED COMPONENTS HAVING RADIAL LEADS**

Components with radial leads that are soldered in place on the circuit card may be removed by the procedure described in Removal of Transistors if the leads are accessible on the component side of the circuit card. If the leads of the component are not accessible on the component side of the circuit board, the component may be removed by performing the following steps:

1. Use vacuum resoldering unit, if available, to remove solder from each lead on component. If vacuum resoldering unit is not available, exert slight pressure and apply tip of soldering iron to tip of lead. Keep soldering iron away from circuit etch. As lead absorbs heat, solder will melt. When solder has melted, in and around lead hole, quickly remove solder with solder-removing tool. Repeat this procedure for each lead associated with component to be removed.
2. Remove component from circuit card.

**REMOVAL OF TRANSISTORS**

The transistor connection points in a given circuit may not be keyed. Therefore, when replacing a transistor, it is possible to insert the replacement transistor backwards to reverse the emitter and collector leads. For this reason, before the transistor is unsoldered from the circuit, identify the emitter and collector terminals in the circuit. Mark the emitter terminal connection point in the circuit with a pencil, a piece of chalk, or a crayon before removing the transistor. The transistor may then be removed.

**SOLDERED COMPONENT REPLACEMENT**

Horizontally mounted components rated at less than 1 watt and with pigtail leads that are inserted in plated-through eyelets or in unsupported holes should be mounted flush with the board surface. Components rated at 1 watt or more should be mounted with 1/16-inch clearance between the component and the surface of the board.

**COMPONENT REPLACEMENT IN EYELETS**

Components may be placed in circuit cards that have eyelets by performing the following steps:

**NOTE**

See Soldered Component Replacement (page 3-7) for component clearance requirements.

1. Verify all polyurethane coating has been removed from pads on both sides of circuit card.
2. Apply well-tinned tip of soldering iron as close as possible to eyelet-component lead intersection.
3. Feed rosin-cored solder to pad-eyelet junction. When solder flows, follow flow around eyelet with solder until entire joint is covered. Remove iron immediately. Use as small an amount of solder as is practical and still cover entire joint.
4. Allow soldered joint to cool at least 5 seconds without disturbing joint. Any disturbance during solidification may cause a fracture or a cold-solder joint.
5. On reverse side of circuit card, trim lead as flush as possible.
6. Repeat steps 2 thru 4 for each lead on component.
7. Encapsulate component using method described in Repair of Polyurethane Conformal Coating (page 3-8).

**COMPONENT REPLACEMENT IN PLATED-THROUGH HOLES**

Components may be replaced in plated-through holes by performing the following steps:

**NOTE**

See Soldered Component Replacement (page 3-7) for component clearance requirements.

1. Verify polyurethane coating has been removed from pads on both sides of circuit card.
2. Apply well-tinned tip of soldering iron as close as possible to component lead-pad junction.

**CIRCUIT CARD REPAIR PROCEDURES (5 of 9)**

3. Feed rosin-cored solder to component lead-pad junction opposite soldering tip. When solder flows, follow flow around component lead-pad junction with solder until entire joint is covered. Remove iron immediately. Use as small an amount as is practical and still cover entire joint.
4. On reverse side of board, trim lead as flush as possible.
5. Opposite side of board need not be soldered, if entire inner surface of hole has been soldered.
6. Repeat steps 2 thru 5 for each lead on component.
7. Encapsulate component by method described in Repair of Polyurethane Conformal Coating (page 3-8).

**REPAIR OF POLYURETHANE CONFORMAL COATING**

The polyurethane conformal coating seals (encapsulates) the circuit card and components from moisture and dust. The coating should not be relied upon to impart mechanical strength for handling. Discontinuities in the polyurethane conformal coating, such as holes caused by test probes, areas scraped for component replacement or etch repair, burned areas caused by the soldering iron, and discontinuities caused by an uncoated replacement component itself may be repaired by performing the following steps.

**WARNING**

Solvents used in this procedure are flammable and must be kept from open flame, heat, and sparks. Keep containers tightly closed and store them in a cool place when not being used. The solvent must be used in only an adequately ventilated environment. Avoid breathing vapors and repeated contact with skin. Clean hands thoroughly before smoking, eating, or drinking.

1. Prepare mixture of polyurethane conformal coating by following manufacturer's instructions. Solvent may be added as required.
2. Apply thin, smooth, uniform coating with small (1/2 inch) brush to all areas requiring coverage.

**WARNING**

Handling hot items presents a serious injury potential. Heat-protective gloves are required.

3. Cure coating in oven set at 165°F for 1 1/2 hours or by letting coating stand at room temperature 24 hours.

**REPAIR OF DAMAGED FIBERGLASS EPOXY PARTS**

Damaged fiberglass parts may be repaired by performing the following steps.

**NOTE**

For parts other than circuit boards, no more than 10 percent of the surface area will be repaired.

**NOTE**

For circuit boards, the area to be repaired will not exceed 1 square inch; the maximum depth of repair will not exceed 50 percent of the original laminate thickness; misdrilled holes that do not interfere with the function of the circuit board will remain unrepaired; and minor cracks that do not go through the entire thickness of the laminate may be repaired according to the following procedure.

1. Sand or scrape area to be repaired using 80 to 180 grit sandpaper to remove all traces of burned or charred laminates. In case of minor crack, scrape through to entire depth of crack.
2. Wipe surface at least twice with clean cloth moistened with acetone and allow to dry thoroughly.
3. Using epoxy compound, empty glass vial of catalyst and syringe of Epon into aluminum cup and mix to a complete homogeneous condition.

**NOTE**

The pot life of the epoxy mixture is approximately 30 minutes. All material not used within 30 minutes must be discarded.

4. Immediately apply epoxy mixture to damaged area making sure to thoroughly wet area to be repaired.
5. Apply sufficient material to cover entire area to be repaired. Add small crown of material to allow for shrinkage.

**WARNING**

Handling hot items presents a serious injury potential. Heat-protective gloves are required.

6. Allow required area to air cure 16 hours minimum or heat cure in oven 1 hour at 150 ±10°F.
7. Sand or scrape crown of repair until repair is relatively smooth and even with original laminate.

**MODIFICATION OF SOLDER-PLATED PRINTED WIRING CIRCUIT CARDS**

Solder-plated printed wiring circuit cards may be modified by brazing gold-plated copper wire to solder-plated copper conductors. The procedural steps are as follows.

**NOTE**

No more than two modification jumpers are allowed to be brazed on one printed wiring pad. Joints are not allowed on printed circuit conductors that are less than the width of the coined (flattened) jumper wire end.



CIRCUIT CARD REPAIR PROCEDURES (6 of 9)

NOTE

This procedure may be performed only by personnel qualified as parallel gap welding operators.

1. Technical personnel familiar with function of the circuit must determine two points to which jumper wire must be attached.
2. Bend a 30-gage insulated, gold-plated, solid copper jumper wire to designated tabs. Cut to required length.
3. Remove insulation for distance between 6 and 7 millimeters (1/4 and 5/16 inch) from each end of wire.
4. With coining tool, coin (flatten) gold-plated copper wire ends to approximately 0.13 millimeter (0.005 inch) thickness by 2.54 millimeters (0.100 inch) long by 0.38 millimeter (0.015 inch) wide as shown below.

NOTE

All dimensions are approximate.

5. Braze coined (flattened) wire to printed circuit conductor pad using parallel gap welding machine according to following schedule. Single wires or double wires can be brazed to one circuit pad, as shown below.
6. Encapsulate jumper wire as described in steps 7 thru 10.

**WARNING**

Use Freon in an adequately ventilated area. Avoid prolonged or repeated breathing of vapor. Avoid contact with skin and eyes. Do not take internally.

7. Clean area to be encapsulated, using Freon TMC solvent.

**WARNING**

Adhesives are irritating to the skin and eyes upon contact, and may emit harmful vapor. Use only with adequate ventilation. Avoid all skin and eye contact. Use protective clothing such as rubber gloves, apron, and eye protection. Wash off immediately any accidentally contaminated skin area. Hand-washing facilities and eye-wash fountain should be provided. Do not take internally.

8. Use any one of Narmco Epoxy Adhesive Kits No. 3135 in recommended tools list (page 3-4). If frozen premix kit is used, allow to thaw to room temperature before use. If either of two-part kits is used, mix approximately equal quantities of part A and part B, using disposable aluminum cup for mixing. Mix thoroughly.

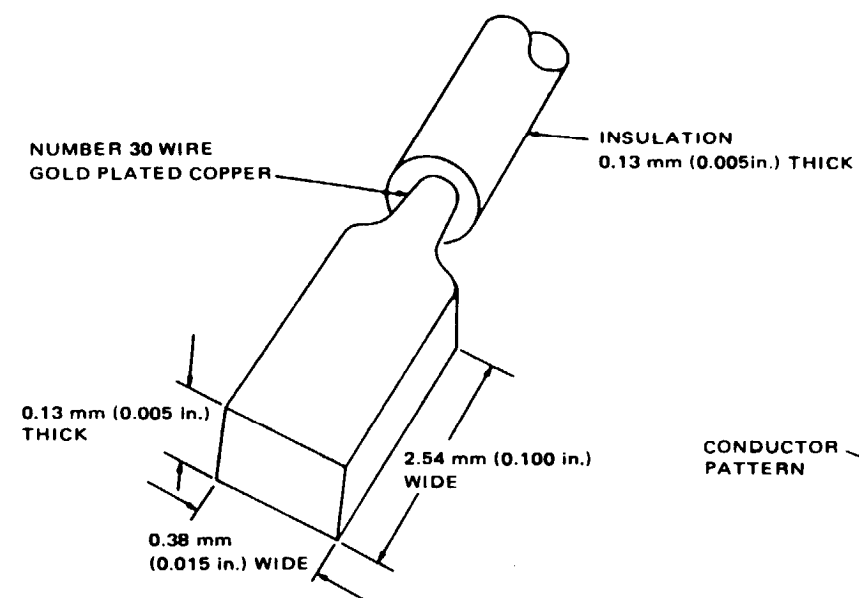

NOTE: ALL DIMENSIONS ARE APPROXIMATE

COINED 30-GAGE WIRE END

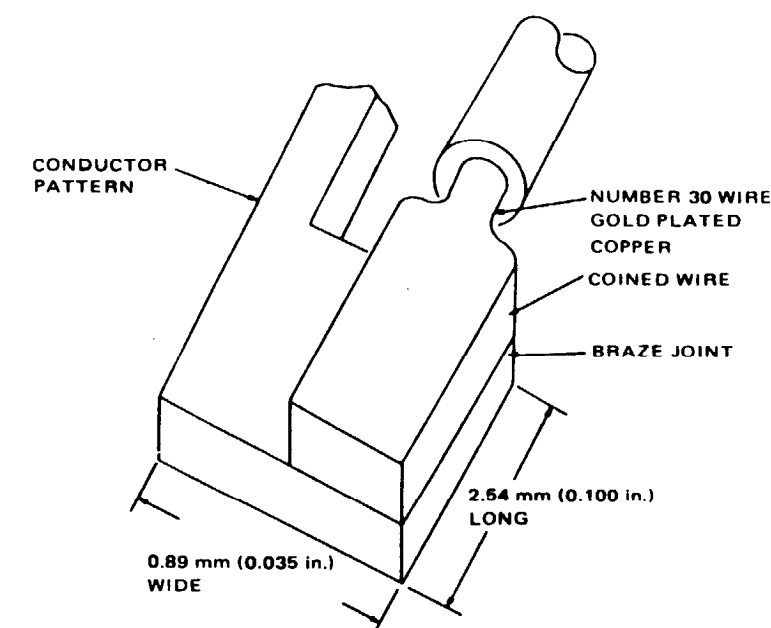

NOTE: ALL DIMENSIONS ARE APPROXIMATE

SINGLE-WIRE ATTACHMENT TO PRINTED CIRCUIT PAD

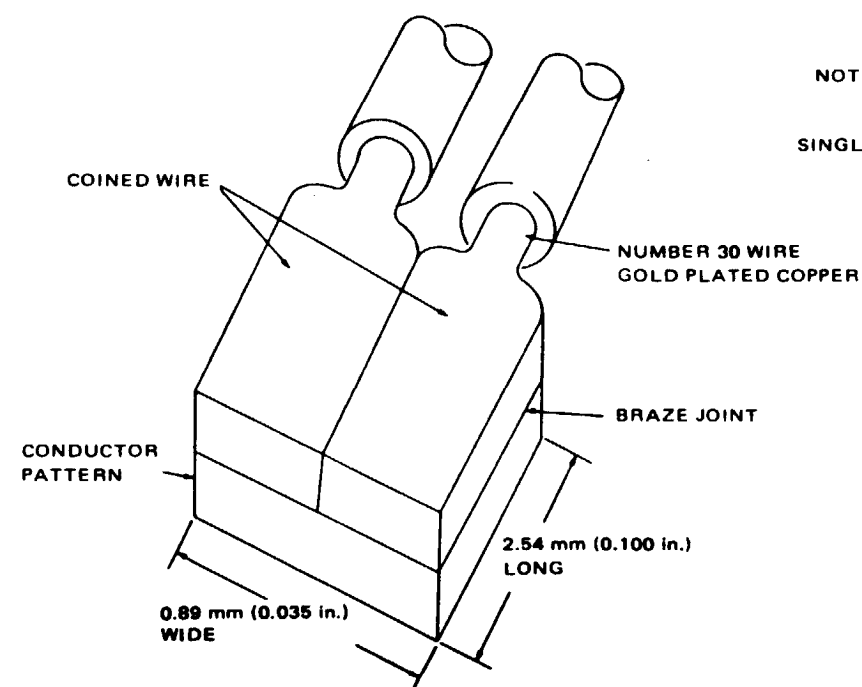

NOTE: ALL DIMENSIONS ARE APPROXIMATE

DOUBLE-WIRE ATTACHMENT TO PRINTED CIRCUIT PAD

**CIRCUIT CARD REPAIR PROCEDURES (7 of 9)**

9. Bond jumper wire to printed wiring board by applying spot of adhesive (prepared in step 8) to minimum diameter of 6.35 millimeters (1/4 inch) at intervals of 5 centimeters (2 inches). It is not necessary to encapsulate brazed joint. Avoid applying adhesive to any area that may be subsequently soldered.

	<u>Single Wire</u>	<u>Double Wire</u>
Weld duration	8 — 10 ms	8 — 10 ms
Weld voltage	0.63 — 0.66 v	0.66 — 0.68 v
Weld force	1.3 — 2.3 kg (3 — 5 lb)	1.3 — 2.3 kg (3 — 5 lb)
Electrode gap	0.38 — 0.50 mm (0.015 — 0.020 in.)	0.38 — 0.50 mm (0.015 — 0.020 in.)

**WARNING**

Handling hot items presents a serious injury potential. Heat-protective gloves are required.

10. Allow adhesive to gel 1 hour minimum at room temperature and then bake 1 hour minimum at temperature of 150 ±1 0°F, or allow adhesive to air dry at room temperature 24 hours minimum. If adhesive is oven cured, allow to cool at room temperature after removal from oven.

**REPAIR OF BROKEN THERMAL MOUNTING PLATE POWER OR GROUND TABS**

Broken thermal mounting plate power or ground tabs may be required using copper jumper wire by performing the following steps:

1. Technical personnel familiar with function of circuit must determine two points to which copper jumper wire is to be attached.
2. Form 26-gage insulated copper jumper wire to designated points and cut to required length.
3. Strip a distance of 1/4 to 5/16 inch from wire ends.

**CAUTION**

The areas to be soldered must be heated until the solder flows. Overheating can damage the board or nearby components. The wires being soldered must not be allowed to move in relation to one another until the solder has completely solidified.

4. Solder each end of jumper wire, as described in steps 6 thru 8.

**WARNING**

Adhesives are irritating to the skin and eyes upon contact, and may emit harmful vapor. Use only with adequate ventilation. Avoid all skin and eye contact. Use protective clothing such as rubber gloves, apron, and eye protection. Wash off immediately any accidentally contaminated skin area. Hand-washing facilities and eye-wash fountain should be provided. Do not take internally.

6. Use any one of Narmco Epoxy Adhesive Kits No. 3135 in recommended tools list (page 3-4). If frozen premix kit is used, allow to thaw to room temperature before use. If either of two-part kits is used, mix small, approximately equal quantities of part A and part B, using disposable aluminum cup for mixing. Mix thoroughly.
7. Bond jumper by applying uniform coat of adhesive over entire length of jumper wire. Do not use more adhesive than necessary to completely cover jumper wire.

**WARNING**

Handling hot items presents a serious injury potential. Heat-protective gloves are required.

8. Allow adhesive to gel minimum of 1 hour at room temperature, then bake 1 hour minimum at temperature of 150 ±10°F; or allow adhesive to air dry at room temperature after removal from oven.

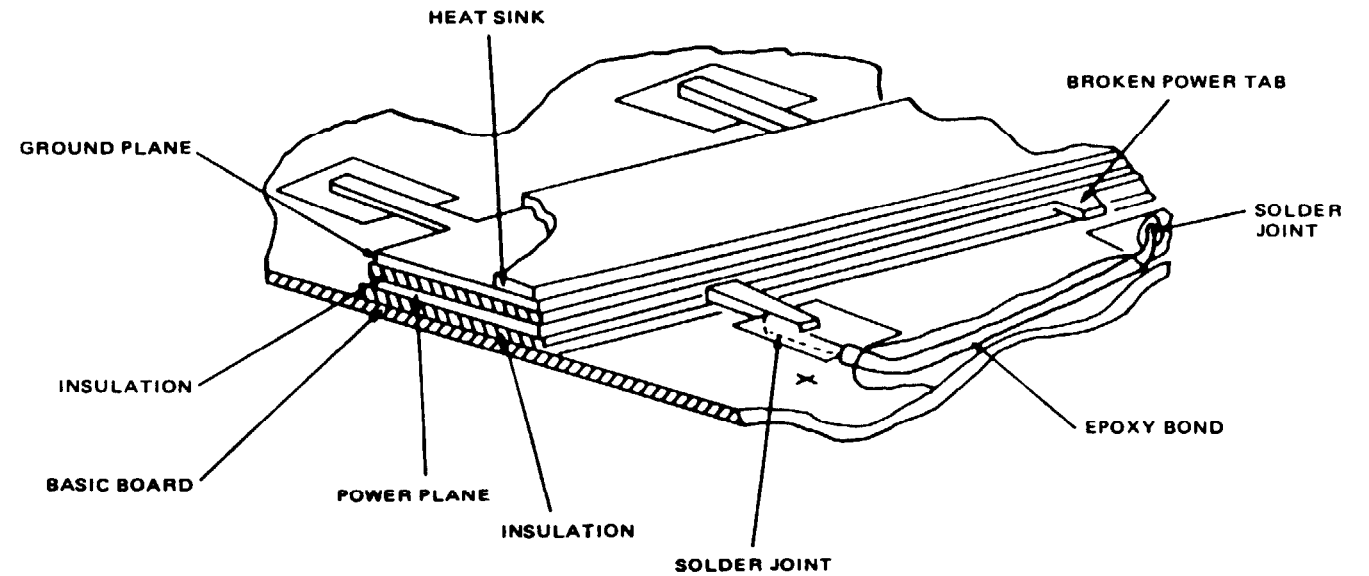

**CIRCUIT CARD REPAIR PROCEDURES (8 of 9)****REPAIR OF CONCEALED SHORT CIRCUITS IN PRINTED WIRING ASSEMBLIES**

Concealed short circuits in printed wiring assemblies may be required by performing the following steps:

**NOTE**

Jumper wires will be installed on the rear side of the assembly whenever possible. If necessary, jumper wires may be installed on component side, provided they do not cross over the top of a component.

**NOTE**

The repair of concealed short circuits involves three steps (1) isolation of the shorted area, (2) cutting the conductors at each side of the short, and (3) restoring the continuity by the installation of jumper wires.

1. Technical personnel familiar with the function of circuit must determine area of short circuit, conductors to be cut, and jumper wires to be installed.
2. Cut and remove bit of circuitry 1/8 inch in each shorted conductor on each side of short.
3. Form 26-gage insulated copper jumper wires between designated points on each side of short circuit area.
4. Strip ends of each jumper wire a distance of 1/4 to 5/16 inch.

**CAUTION**

The areas to be soldered must be heated until the solder flows. Overheating can damage the board or nearby components.

**NOTE**

If there is an eyelet or plated-through hole not being used for a component termination, it may be used as a jumper wire termination.

5. If end of any one of jumper wires is to be attached to an etched conductor, plate stripped end of wire on conductor in direction parallel to etched conductor and solder in place. Then solder ends of other jumper wires in place.
6. Encapsulate each of jumper wires as described in steps 7 thru 10.

**WARNING**

Use Freon in an adequately ventilated area. Avoid prolonged or repeated breathing of vapor. Avoid contact with skin and eyes. Do not take internally.

7. Clean areas to be encapsulated using Freon TMC solvent. Verify all traces of rosin flux are removed.

**WARNING**

Adhesives are irritating to the skin and eyes upon contact, and may emit harmful vapor. Use only with adequate ventilation. Avoid all skin and eye contact. Use protective clothing such as rubber gloves, apron, and eye protection. Wash off immediately any accidentally contaminated skin area. Hand-washing facilities and eye-wash fountain should be provided. Do not take internally.

8. Use any one of Narmco Epoxy Adhesive Kits No. 3135 in recommended tools list (page 3-4). If frozen premix kit is used, allow to thaw at room temperature prior to use. If either of two-part kits is used, mix approximately equal quantities of part A and part B, using disposable aluminum cup for mixing. Mix thoroughly.
9. Bond jumper wires to circuit board by applying uniform coating of adhesive over entire length of each jumper wire. Do not use more than necessary to completely cover jumper wires.
10. Allow adhesive to gel for 1 hour minimum at room temperature and then bake 1 hour minimum at temperature of  $150 \pm 10^\circ$  F; or allow adhesive to dry at room temperature 24 hours minimum. If adhesive is oven cured, allow to cool at room temperature after removal from oven.

**CIRCUIT CARD REPAIR PROCEDURES (9 of 9)**

**REPAIR OF THERMAL MOUNTING PLATE ON HIGH-DENSITY PRINTED WIRING BOARDS**

Thermal mounting plate on high-density printed wiring boards may be repaired by performing the following steps:

1. Carefully clean out all loose adhesive from area between lifted thermal mounting pad and printed wiring board using orange stick or equivalent hand tool.

**WARNING**

Use Freon in an adequately ventilated area. Avoid prolonged or repeated breathing of vapor. Avoid contact with skin and eyes. Do not take internally.

2. Clean area to be repaired with Freon TMC solvent to remove residual surface contaminants.

**WARNING**

Adhesives are irritating to the skin and eyes upon contact, and may emit harmful vapor. Use only with adequate ventilation. Avoid all skin and eye contact. Use protective clothing such as rubber gloves, apron, and eye protection. Wash off immediately any accidentally contaminated skin area. Hand-washing facilities and eye-wash fountain should be provided. Do not take internally.

3. Any one of Narmco Epoxy Adhesive Kits No. 3135 in recommended tools list (page 3-4) may be used as repair adhesive. If frozen premix kit is used, allow to thaw at room temperature before use. If either of two-part kits is used, mix small approximately equal quantities of part A and part B, using disposable aluminum cup for mixing. Mix thoroughly.
4. Carefully apply thin, smooth coat of adhesive under thermal mounting pad. Do not use more adhesive than necessary.
5. Carefully clamp thermal mounting plate to board.
6. Allow adhesive to gel at least 1 hour at room temperature.

**WARNING**

Handling hot items presents a serious injury potential. Heat-protective gloves are required.

7. Bake board in oven at 150 ±10°F at least 1 hour.
8. Remove board from oven and allow to cool to room temperature. Remove clamp(s).

**REPAIR OF DEFECTIVE PLATED-THROUGH HOLE**

Defective plated-through holes can be repaired by performing the following steps.

**NOTE**

Remove any component that would interfere with the performance of this repair according to the procedure contained in Removal of Soldered Components Having Axial Leads (page 3-7) or Removal of Soldered Components Having Radial Leads (page 3-7). Handle removed component with care because it may be reinstalled upon the completion of this repair.

1. Cut length of 34-gage uninsulated tin-coated wire from 50 to 100 millimeters (2 to 4 inches) long and pass it through defective plated-through hole. If wire will not pass through hole due to solder buildup hole may be cleared with use of vacuum desoldering unit.
2. Hold one end of wire against one side of circuit card and pull other end taut and down against other side of circuit card, being careful to avoid aligning wire with any circuit traces emerging from pad.
3. Turn circuit card over and repeat step 2 for opposite side.
4. Using solder, soldering iron, and flux, carefully solder wire to pad using minimum amount of solder.
5. Turn circuit card over and repeat step 4 as required.

**CAUTION**

Do not cut down into the circuit card pad when trimming the wire.

6. Using X-acto knife, very carefully cut down into wire just at, or ahead of, where it emerges from solder.

**NOTE**

The wire should not extend past the edge of the pad to which it is soldered.

7. Grasp free end of wire and lift it slowly so that it separates at cut produced in step 6.
8. Turn circuit card over and repeat steps 6 and 7 for other side of repair.
9. Apply small amount of soldering flux to each side of repair, and using soldering iron, touch up solder joints to cover any of copper wire exposed by trimming of leads.

**WARNING**

Isopropyl alcohol is flammable. Keep away from heat and open flame. Vapors may be harmful. Use with adequate ventilation. Avoid prolonged or repeated breathing of vapor. Avoid eye contact. Do not take internally.

10. Clean repaired area with Isopropyl alcohol.
11. If component has been removed in order to accomplish this repair, and if it is visually and mechanically sound, replace component according to procedure in paragraphs titled Soldered Component Replacement (page 3-7), Component Replacement in Eyelets (page 3-7), or Component Replacement in Plated-Through Holes (page 3-8). If component is defective, replace with an identical new component.

Section II. CLEANING AND EXAMINATION

	Page
General .....	3-13
Cleaning .....	3-14
Examination .....	3-15

**GENERAL**

This section contains general information for the cleaning and inspection of the radio set equipment. The term cleaning means all those processes by which dirt or contaminants are removed from the equipment without causing damage to the equipment or hazard to the health of personnel. The term examination means all those processes by which the equipment is compared or measured against an acceptable standard for cleanliness, mechanical and electrical (electronic) condition, serviceability, and performance capability.

## **CLEANING**

The general cleaning procedures contained in this section are applicable for field and depot maintenance and rebuild.

### **WARNING**

When using a compressed airjet, use eyeshields.

### **WARNING**

When using solvents, provide proper ventilation, avoid prolonged contact, and do not smoke. Solvents must meet all pertinent specifications regarding toxicity, flammability and allergenic effect.

### **CAUTION**

Compressed air must be clean, dry, and at a maximum pressure of 28 psi. Do not overtake the force of the airjet when cleaning delicate parts.

### **CAUTION**

Certain solvents will damage insulation. Do not use solvents chemically similar to Chlorothene or Gtyptal to clean module connectors. Use only denatured alcohol for this purpose.

## **EXTERNAL**

Clean the exterior of the radio set by using an airjet. If accumulated dirt cannot be removed by the airjet alone, use a medium-stiff camel hair or similar brush to aid the airjet action.

An approved solvent or detergent may be used to remove grease, oil, or other contaminants, provided that it is not allowed to run into the insulated sleeving of cable assemblies and wiring. All solvents and detergents tend to cause binding if allowed to seep into shaft bearings or other moving parts.

## **INTERNAL**

The interior of the RT and amplifier/coupler *and* separate disassembled parts may be cleaned by using one or more of the following methods

1. Clean, dry, lint-free cloth.
2. Airjet and brush.
3. Flushing and dipping of separate mechanical parts using an approved solvent or detergent,
4. Flushing and dipping of separate nonmetallic parts in denatured alcohol only.

## **CORROSION CONTROL**

The following periodic checks and services are required for prevention and control of corrosion and fungus of the radio set.

1. inspect the exterior of each unit for corrosion and fungus (particularly around the controls, connectors, and latches). Reference USAF TO 1-1-689.
2. Remove all corrosion and fungus with a cloth and/or brush moistened with cleaning solvent.
3. Repaint all treated areas immediately upon removal of corrosion to alleviate the reoccurrence of corrosion buildup.

## EXAMINATION

The general examination procedures contained in this section are applicable for field and depot maintenance and rebuild. It is expected that the majority of examination for field maintenance will take place during troubleshooting, and that examination will consist of verifying the replaced component is installed correctly and the equipment passes the performance test.

### GENERAL

The term examination is best defined by describing the intent and scope of the inspection work areas, because there are no procedures in this manual that can be separately tailed inspection procedures. The intent and scope of the inspection work areas (which have been given arbitrary names) are described under the subheadings that follow.

### FIRST EXAMINATION

The first, incoming, or receiving examination consists of sorting out the units and modules of the radio set for disposal according to the following criteria:

#### NOTE

The action required by items 1 thru 3 following may not necessarily take place at depot level.

1. Salvage of undamaged parts.
2. Write-off of heavily damaged or missing assemblies.
3. Replacement of written-off assemblies.
4. Scheduling and routing of the units and modules or the complete radio set, as applicable, for rebuild processing.

### IN-PROCESS EXAMINATION

In-process examination covers a wide overall inspection work area that may be broken down into smaller work areas as follows:

1. **Mechanical and Visual Inspection.** The intent is to quickly determine the obvious aspects of the overall maintenance and rebuild requirement. For example, some damaged connector pins in the RT would not necessarily involve a complete disassembly, but a damaged RT housing would involve an extensive mechanical disassembly.
2. **Troubleshooting inspection.** The objective of troubleshooting is to locate the site of a malfunction, after which repair can be carried out. Thus, troubleshooting is an inspection process that determines how a malfunctioning item of equipment can be made serviceable. However, in many cases, this process may require disassembly (refer to item 3 following), and the repair may actually be carried out during troubleshooting (to prove the correctness of the troubleshooting diagnosis). In this way, troubleshooting inspection also identifies the replacement item.

3. **Disassembly Inspection.** This visual inspection is concerned with the following objectives:
  - a. To detect frayed, burnt, shorting, or broken cables wiring; and dry-jointed, shorted, or grounded solder connections.
  - b. To detect blackened, overheated, broken, or missing electrical/electronic components and parts.
  - c. To detect missing or broken hardware, loose mounting, and missing mechanical parts.
  - d. To detect mechanical binding, sticking, looseness, and excessive wear of moving parts.
  - e. To record any action required by items a thru d above, including identification of replacement items for repair.
4. **Reassembly Inspection.** The objective of this inspection is to avoid malfunction or rework after reassembly. The inspection areas are as follows:
  - a. Observance of critical positioning or adjustment of all mechanical and electrical/electronic parts.
  - b. All required hardware is used and correct.
  - c. All required parts are used and correct.
  - d. All required wiring, soldering, and sleeving are correct. This includes correct dressing arrangement of wire harnesses and cables, etc.
  - e. Liquid staking used where required.
  - f. Correction lubrication used where required.
  - g. There is no binding, sticking, or looseness of moving mechanical parts.
  - h. All electrical/electronic parts are correctly orientated for clearances and lead shortness. Printed circuit boards are not under strain due to incorrect mounting.
  - i. No short-circuits or grounds are caused by module case or cover.

### FINAL INSPECTION

The final inspection may be divided into six work areas as follows:

1. Final mechanical and visual inspection of each module following reassembly.
2. Final performance of tests for each module assembly.
3. Final mechanical and visual inspection of units and modules following reassembly.
4. Final performance test for each unit.
5. Final performance tests for radio set.
6. Documentation, packaging, and shipping inspection for the complete radio set, as applicable.

BLANK  
INTENTIONALLY



Section III. FABRICATION OF SPECIAL SUPPORT EQUIPMENT

**GENERAL (1 of 4)**

This section contains drawings for fabrication of test cables, adapters, and fixtures required to perform test, troubleshooting, and alignment of the radio set, units, and modules. Fabrication data is provided for the following items of special support equipment:

1. **A** Modulator/Demodulator Test Extender Cable
2. **B** Antenna Tuner Test Extender Cable

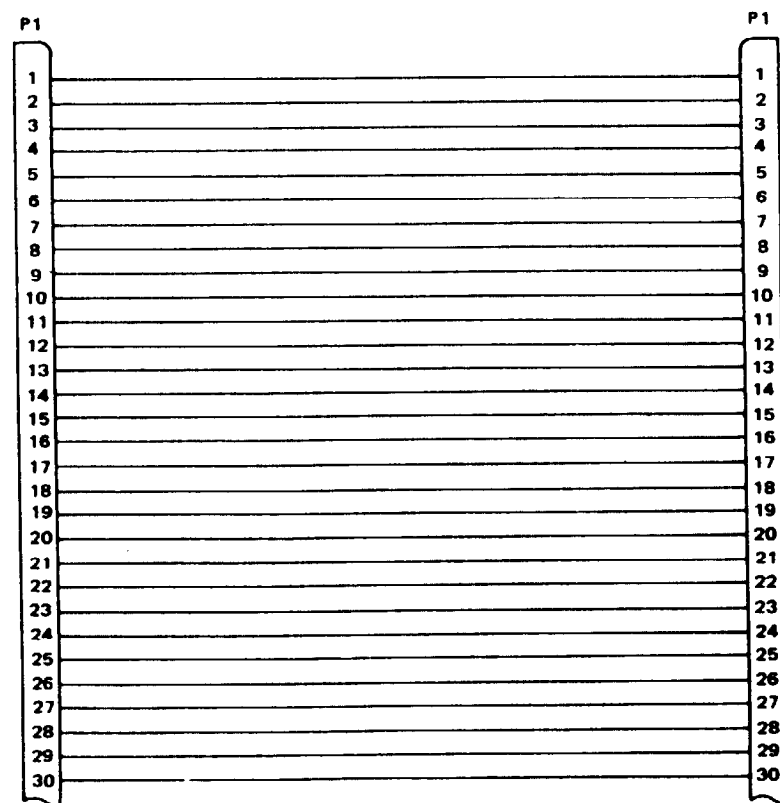
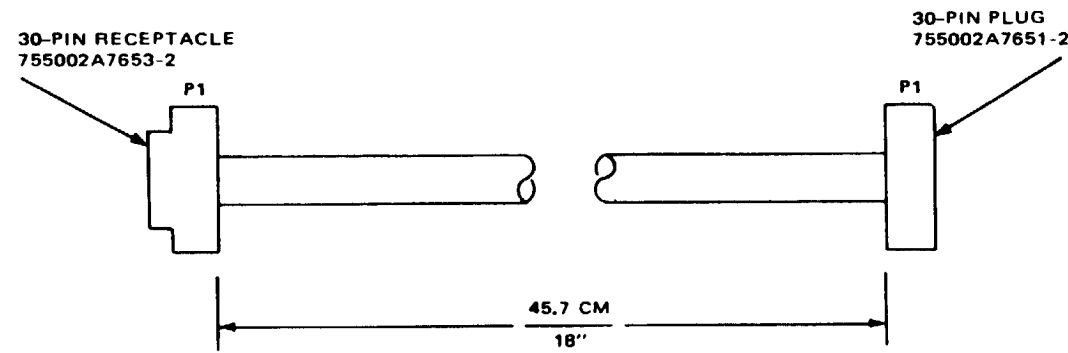

**A** MODULATOR/DEMODULATOR TEST EXTENDER CABLE

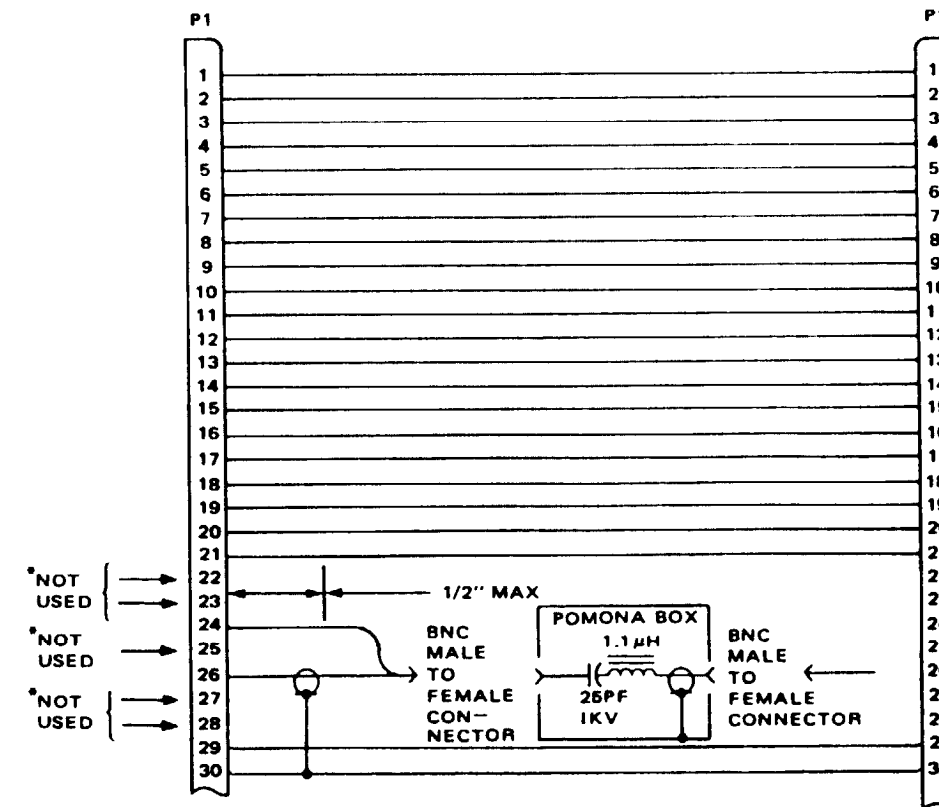
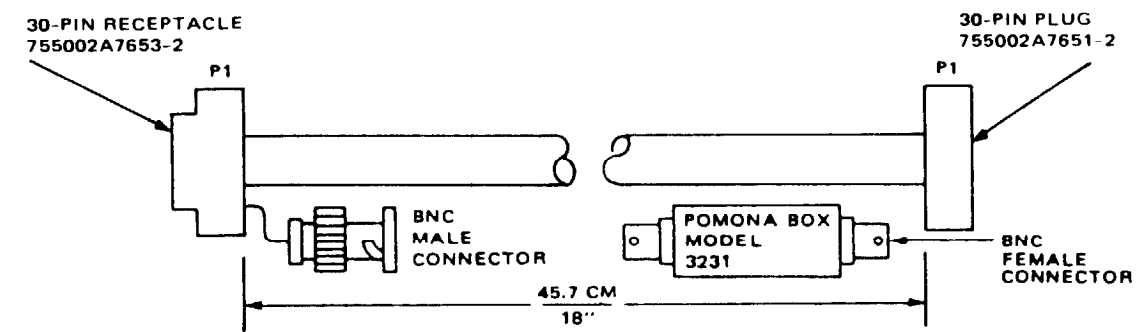

\*REMOVE METAL PORTION OF PIN FROM THE CONNECTOR

**B** ANTENNA TUNER TEST EXTENDER CABLE

**GENERAL (2 of 4)**

- 3. **C** Synthesizer Test Extender Cable
- 4. **D** Harmonic Filter/Power Amplifier Test Extender Cable

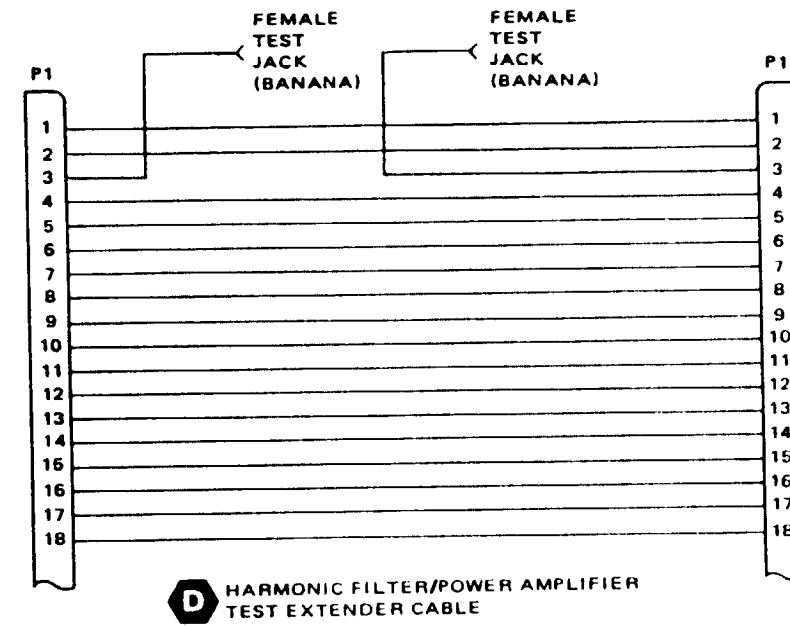
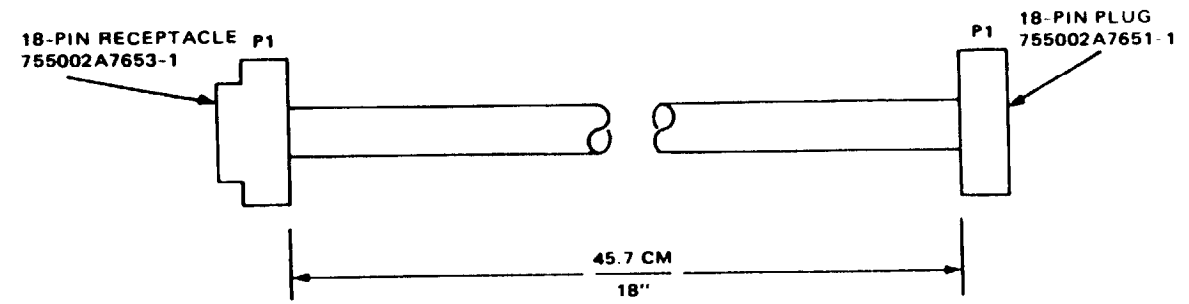
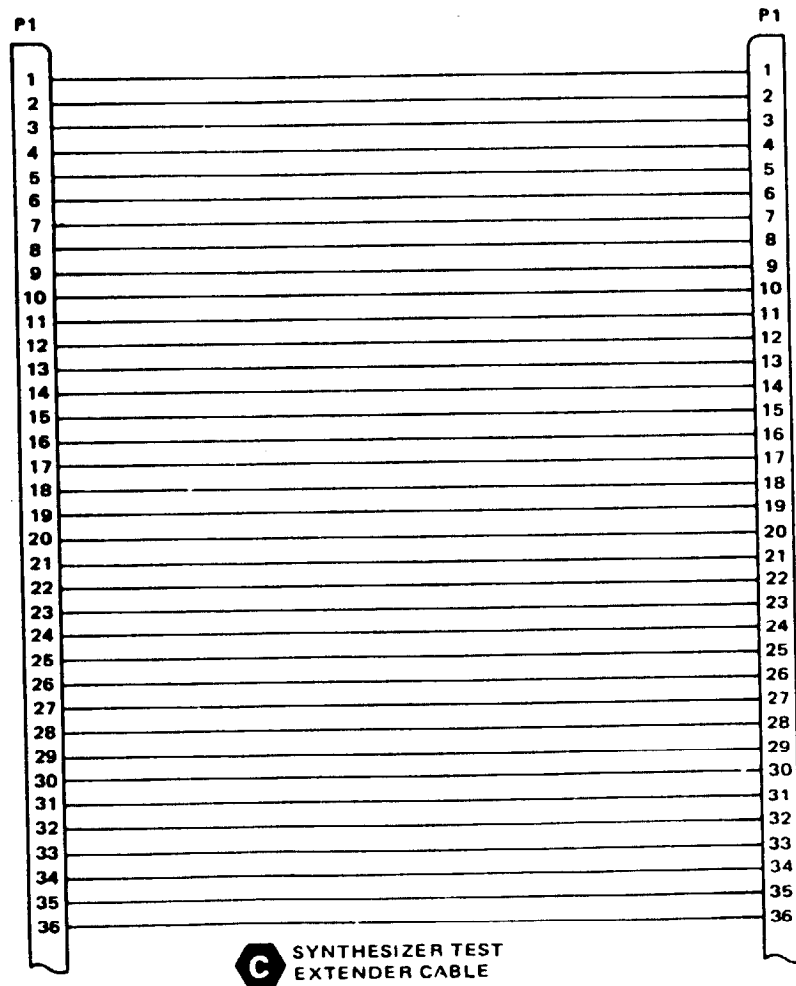
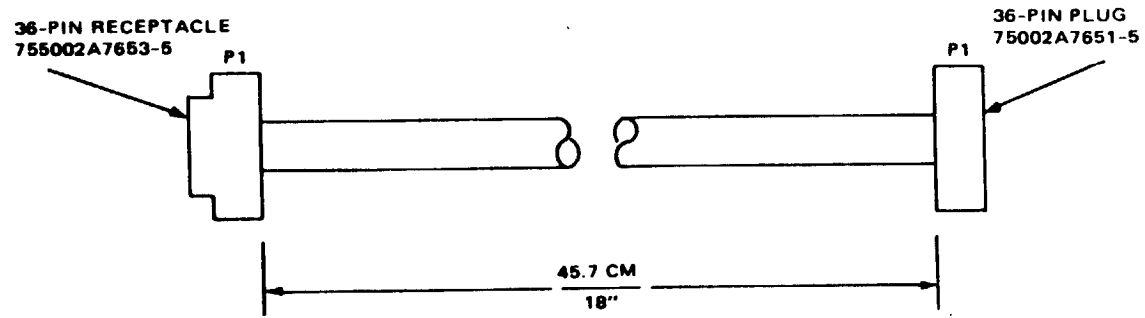

NOTE: ALL WIRE IS 24 AWG

**GENERAL (3 of 4)**

- 5. **A** RF Coax Cable
- 6. **B** RF Extender Cable
- 7. **C** Audio Input/Keying Adapter
- 8. **D** Antenna Adapter
- 9. **E** 100-Ohm Load
- 10. **F** 130-Ohm Load

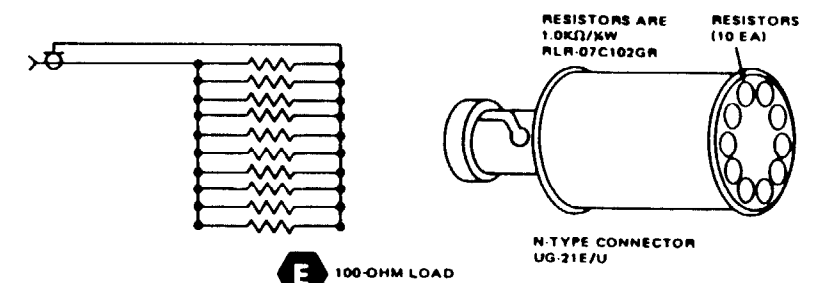
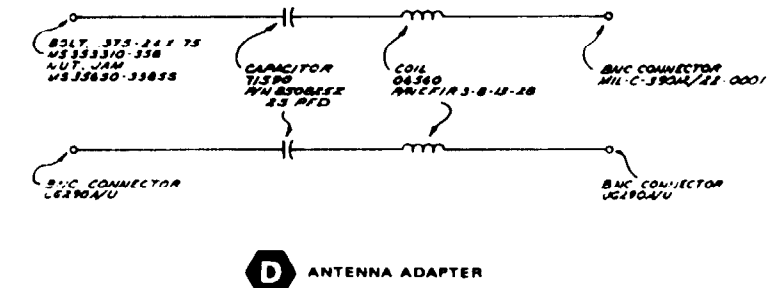
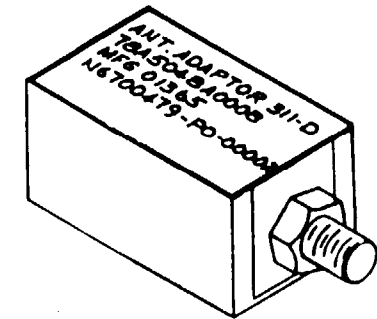
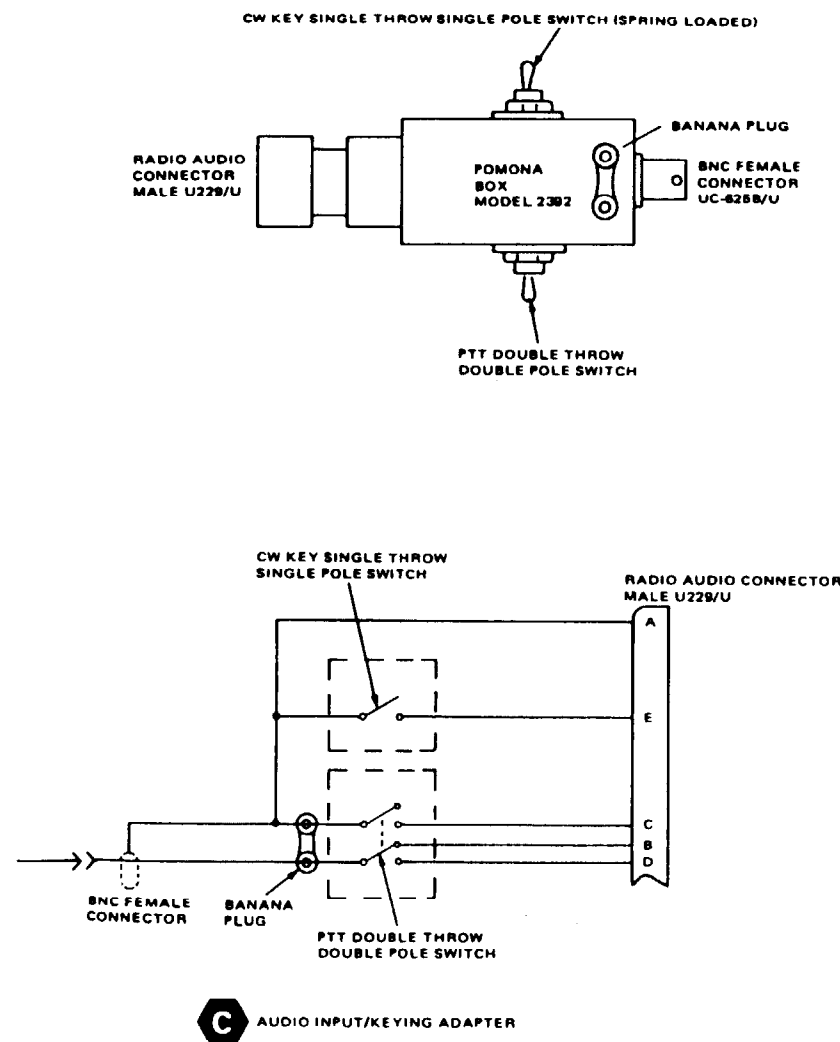
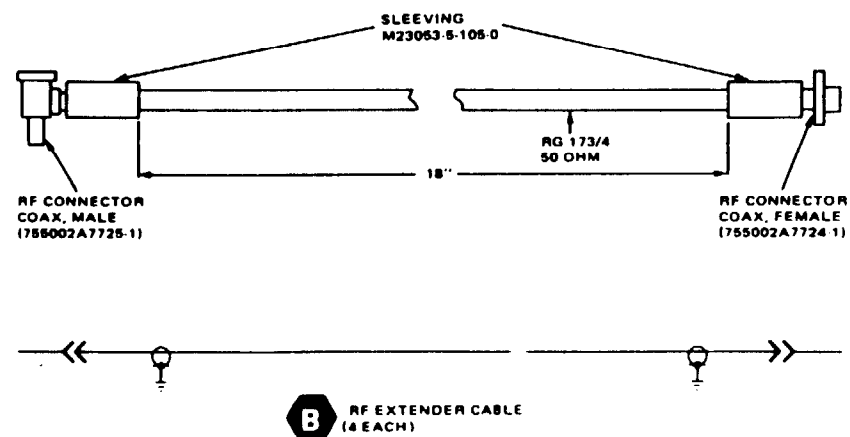
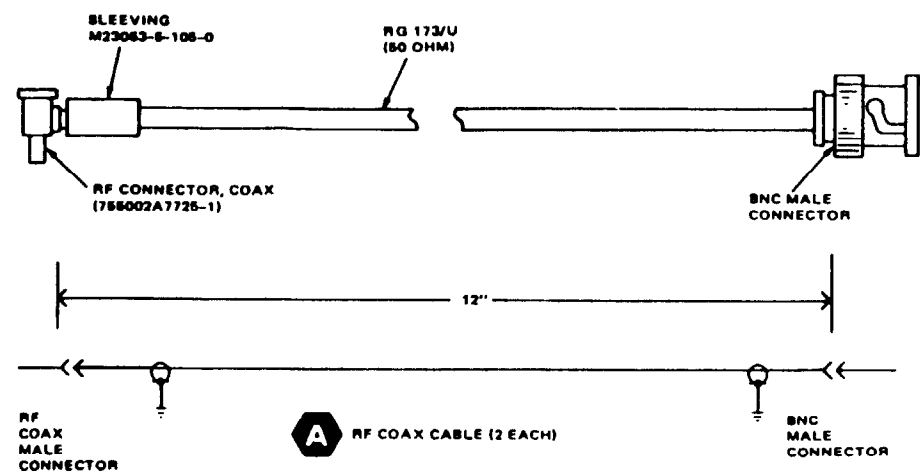

NOTE: CONNECT THE 10 RESISTORS IN PARALLEL. THEN PLACE THEM IN BARREL OF CONNECTOR, AND CONNECT ONE END TO SHIELD AND THE OTHER END TO THE SIGNAL LINE OF CONNECTOR

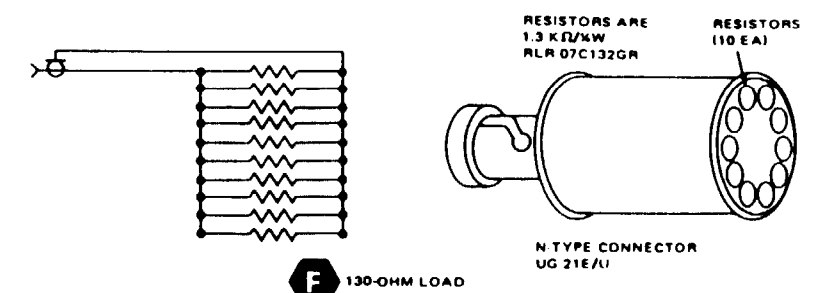

NOTE: CONNECT THE 10 RESISTORS IN PARALLEL. THEN PLACE THEM IN BARREL OF CONNECTOR, AND CONNECT ONE END TO SHIELD AND THE OTHER END TO THE SIGNAL LINE OF CONNECTOR

**GENERAL (4 of 4)**

11. **G** Frequency Converter Test Bed

**FABRICATION INFORMATION**

Troubleshooting of the three frequency converter submodules is best accomplished using three separate frequency converter test beds. Each test bed is a complete and functional modulator/demodulator, with the exception of the test bed extension for either the first, second, or third converter, respectively. The frequency converter under test is plugged into the sockets of the extension (although if a pin is misshaped, a jumper must be inserted).

Fabrication of the test bed extension may be accomplished as outlined below:

**NOTE**

Any equivalent methods or materials may be used. Refer to the Stock List manual for identification of piece parts required.

1. Cut a bare modulator/demodulator printed wiring board out around first, second, and third converter positions.
2. Insert amplifier 50864 sockets into holes for pins.
3. Remove appropriate frequency converter submodule from modulator/demodulator that is to be used as test module.
4. Drill 4 holes in test module for extender pillars. Be extremely careful to avoid damaging any printed wiring in this four-layer PC board.
5. Drill 4 corresponding holes in cut out printed wiring board.
6. Mount extender pillars onto cut out printed wiring board.
7. Connect a shielded wire from each socket to corresponding hole in test module.
8. Mount test bed extension onto test module.

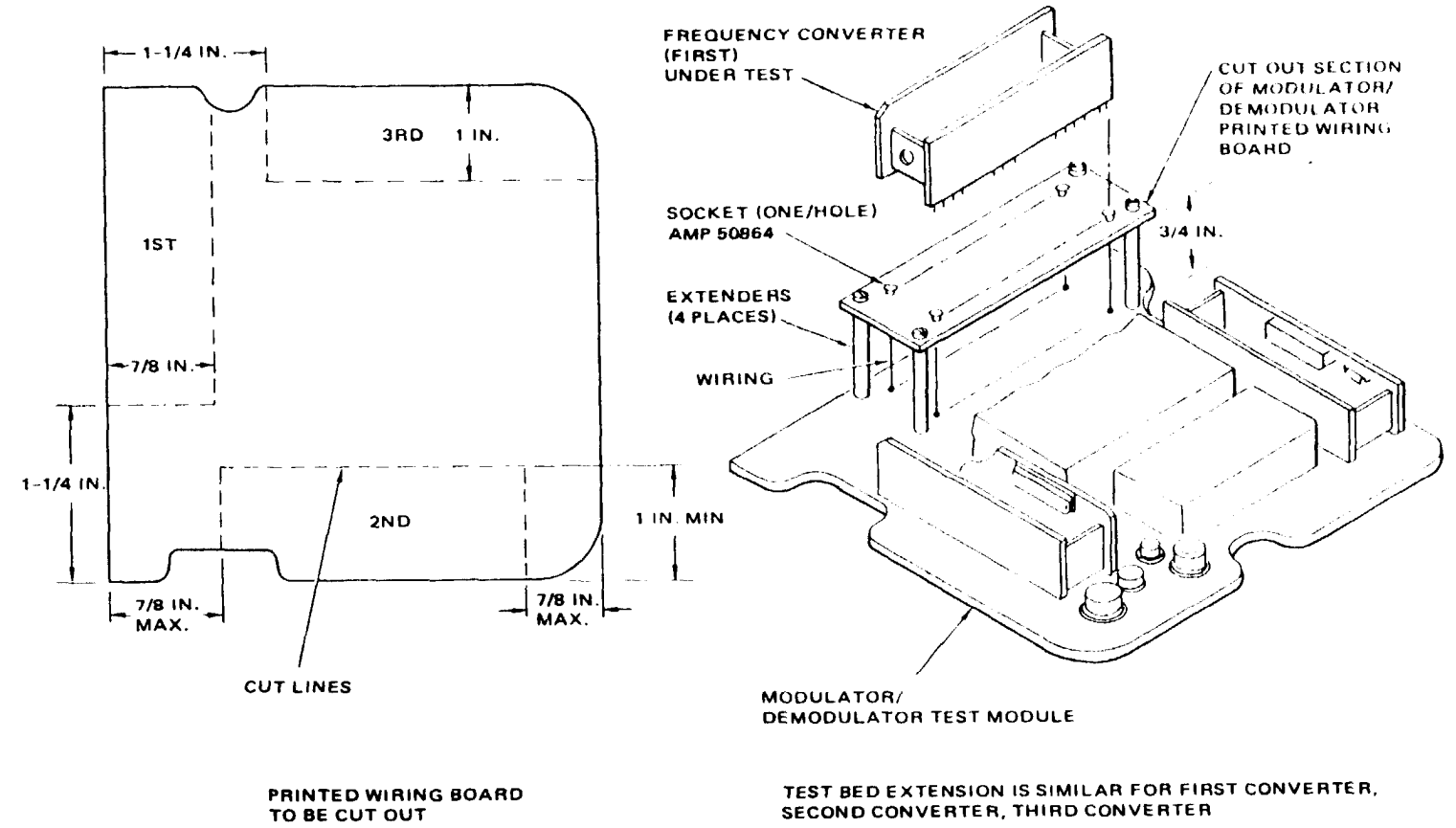

**G** FREQUENCY CONVERTER TEST BED

Section IV. PERFORMANCE TEST AND TROUBLESHOOTING

	Page
General .....	3-21
Performance Test and Troubleshooting .....	3-22

**GENERAL**

Performance test and troubleshooting of the radio set units and modules requires a known good radio set as a test bed. The unit (or module) under test (UUT) replaces the known good unit or module of the test bed radio set, and is connected to the test bed by fabricated test cables.

**PERFORMANCE TEST AND TROUBLESHOOTING (1 of 2)**

The performance test flowcharts provide the necessary procedures and information to completely test the radio, a unit or a module (unit under test). The flowcharts also provide troubleshooting procedures as an aid in fault isolating to a group of components, if the UUT does not pass a performance test.

**USE OF FLOWCHARTS**

The procedure begins at the bubble symbol that reads Unit Under Test. Next, the initial setup block references applicable removal disassembly and reassembly instructions, a test setup diagram, and provides initial switch settings required for the test. The initial setup block is followed by a series of procedural blocks that contain actions required to produce a result; and decision blocks that ask whether the desired result occurred. If the desired result has occurred, the yes pathway is followed; if the desired result did not occur, the no pathway is followed for the troubleshooting procedure. The performance test is successfully completed when the Test Passed bubble symbol is reached. The troubleshooting procedure is completed when a fault-indication block is reached. Once the fault is corrected, the performance test is resumed at the point where first fault indication occurred. If a flowchart is extended to another sheet, the continuation symbol is used. Caution and warning notes appear to alert the user to potential equipment or human hazards.



BEGIN TEST



END OF SHEET 1



INITIAL SETUP BLOCK

BEGIN SHEET 2



CONTINUATION

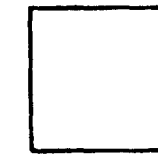

PROCEDURE OR FAULT BLOCK



END TEST

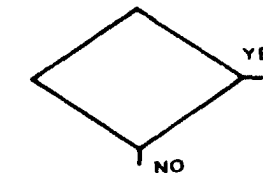

DECISION BLOCK



PROCEDURAL WARNING BLOCK

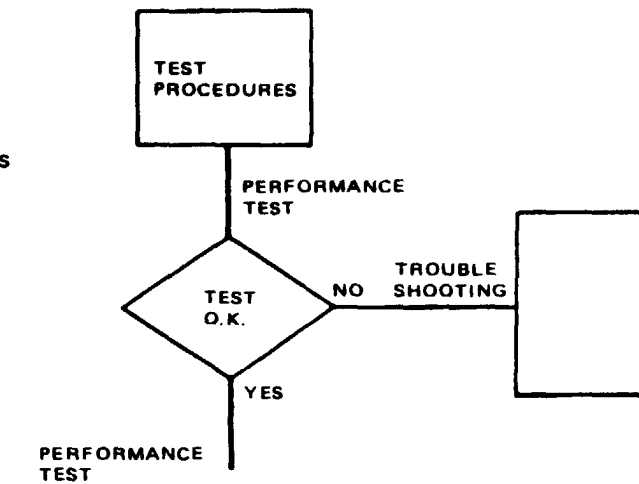

FLOWCHART SYMBOLS

**PERFORMANCE TEST AND TROUBLESHOOTING (2 of 2)**

**TEST AND TROUBLESHOOTING REFERENCE DATA**

The performance test flowcharts are used in conjunction with the supporting data below. The following depicts the arrangement of maintenance information contained in each maintenance chapter.

1. Disassembly and Reassembly Procedures. These procedures provide the information necessary to remove and replace a unit under test.
2. Performance Test Setup Diagrams. The test setup diagrams show what test equipment is required for the performance test and troubleshooting, and how to connect the test equipment unit under test.
3. Alignment Procedures. The alignment procedures are performed when specified in the troubleshooting procedures. They are usually required during troubleshooting to ensure the unit under test is properly aligned before determining faulty components.
4. Functional Block Diagrams. The functional block diagrams may be used as an aid to troubleshooting in conjunction with the flowcharts.
5. Schematic Diagram. The schematics for the unit under test are used to aid in identifying suspected faulty components. For example, if the fault block on the troubleshooting flowcharts calls out Switch Q1 Fault, the schematic is used to identify the components associated with Q1 (ie, capacitors, resistors, inductors, etc). The schematics contain pertinent voltage and waveform data to aid in fault isolation.
6. Component Location Diagrams. The component location diagrams for each unit under test are used for the following three purposes:
  - a. To identify the location of all components in disassembly and reassembly procedures.
  - b. To identify the location of the test points and pins required to monitor waveforms and voltages in the performance test and troubleshooting flowcharts. The numbers printed on the backs of the modules correspond to the test points shown on schematics.
  - c. To identify the location of every replaceable component.

**DESCRIPTION OF COMPONENT LOCATION DIAGRAMS**

The component location diagrams provide physical identification of all replaceable piece parts in the radio set. The component location diagrams provide component location information only; for ordering of piece parts, refer to the Applicable Repair Parts List. There is a separate diagram for the radio set, each unit, each module, and the cable assemblies.

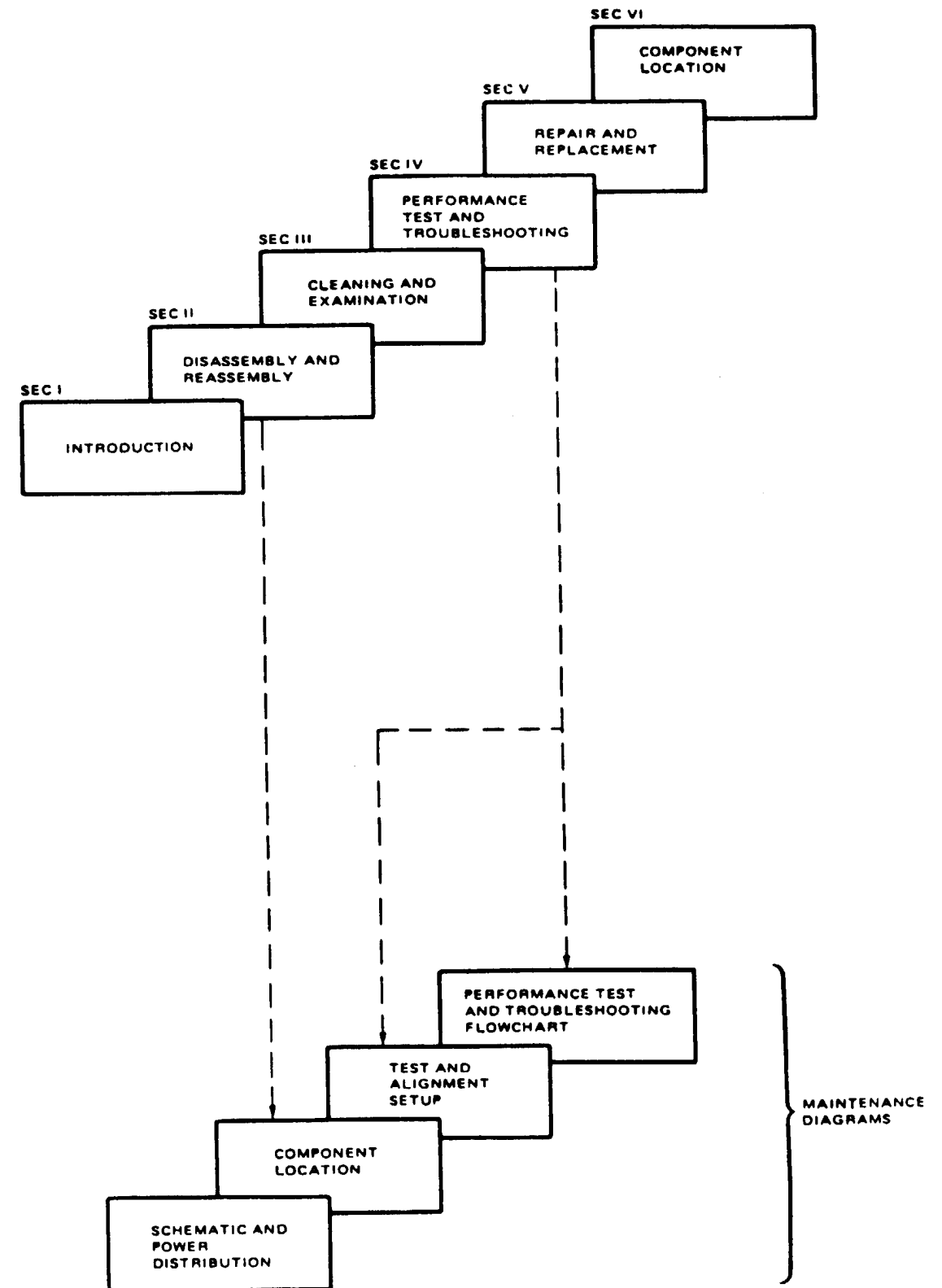

Maintenance Chapter Construction

BLANK  
INTENTIONALLY



Section V. MAINTENANCE DATA FOR ACCESSORIES

	Page
General .....	3-25
Bench Test Cable .....	3-26
Battery Extender Cable .....	3-27
Antenna Base .....	3-27
Telegraph Key .....	3-27
Transit Case .....	3-28

**GENERAL**

This section contains maintenance information for those items of radio set accessory equipment that are unique to the radio set application. The maintenance information is provided on maintenance drawings that include schematics, component location and fabrication data, as applicable. Maintenance drawings are provided for the following items of accessory equipment:

1. Bench Test Cable (page 3-26)
2. Battery Extender Cable (page 3-27)
3. Antenna Base (page 3-27)
4. Telegraph Key (page 3-27)
5. Transit Case (page 3-28)

**BENCH TEST CABLE**

- | ITEM | DESCRIPTION            |
|------|------------------------|
| 1    | Strap, Cover           |
| 2    | Thumbscrew             |
| 3    | Insulator, Red         |
| 4    | Insulator, Black       |
| 5    | Clip, Electrical       |
| 6    | Fuse </td              |
| 7    | Fuse Holder            |
| 8    | Housing, Prot. Ckt.    |
| 9    | Junction Box           |
| 10   | Bracket, Xstr Mounting |
| 11   | Capacitor              |
| 12   | Resistor, R1           |
| 13   | Resistor, R2           |
| 14   | Semiconductor, VR1     |
| 15   | Semiconductor, VR2     |
| 16   | Thyristor, Q1          |
| 17   | Cover, Connector       |
| 18   | Connector, Battery     |
| 19   | Terminal Lug, E1       |
| 20   | Washer, Lock-          |
| 21   | Nut, Hexagon           |
| 22   | Washer, Lock-          |
| 23   | Terminal Lug, E2       |
| 24   | Nut, Hexagon           |
| 25   | Washer, Lock-          |

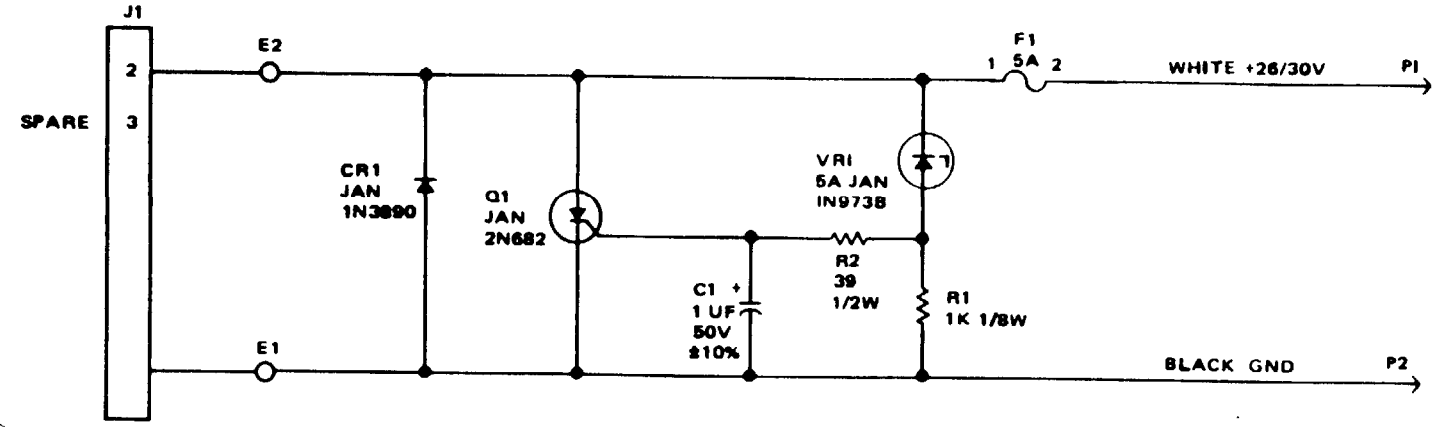
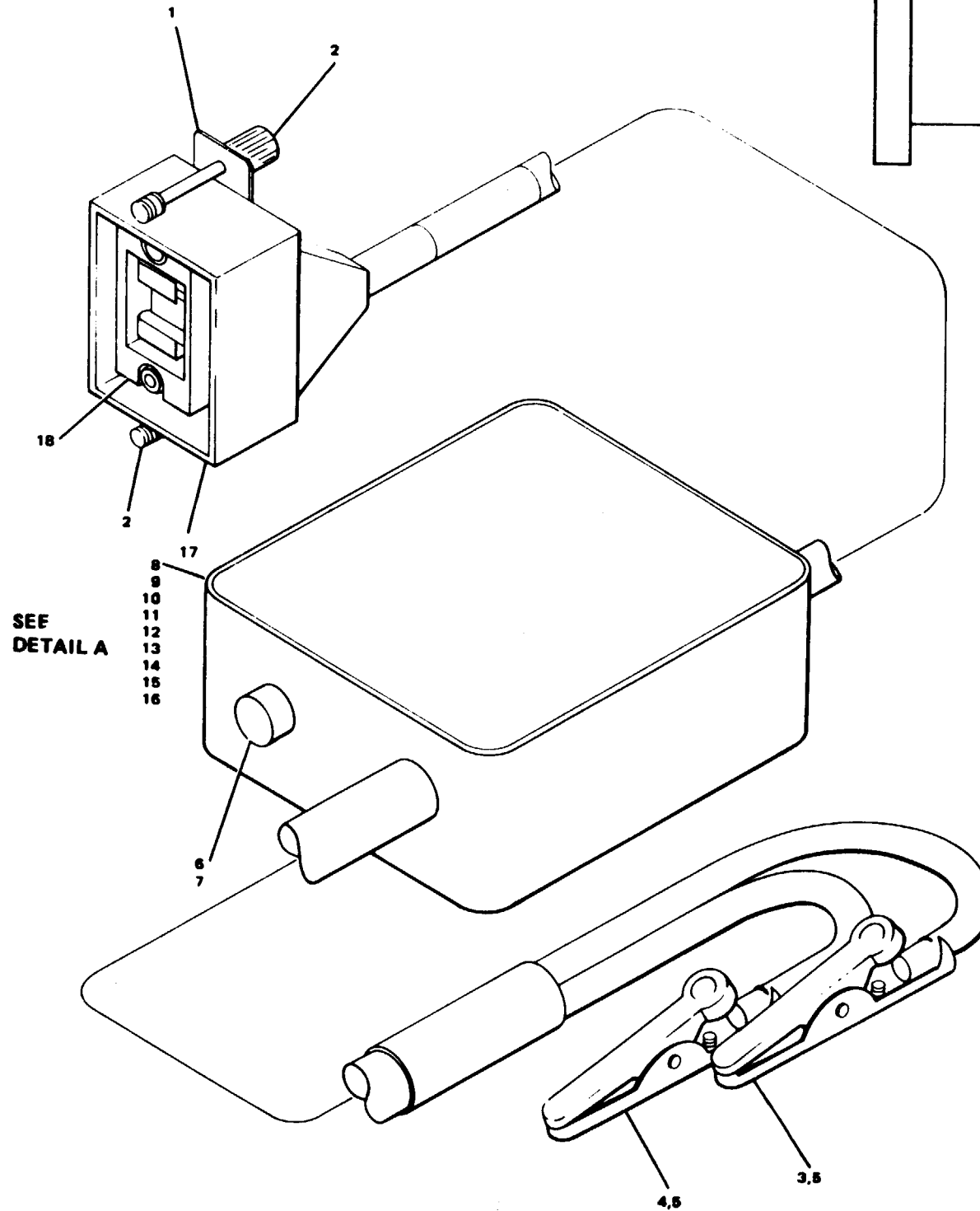

SCHMATIC DIAGRAM

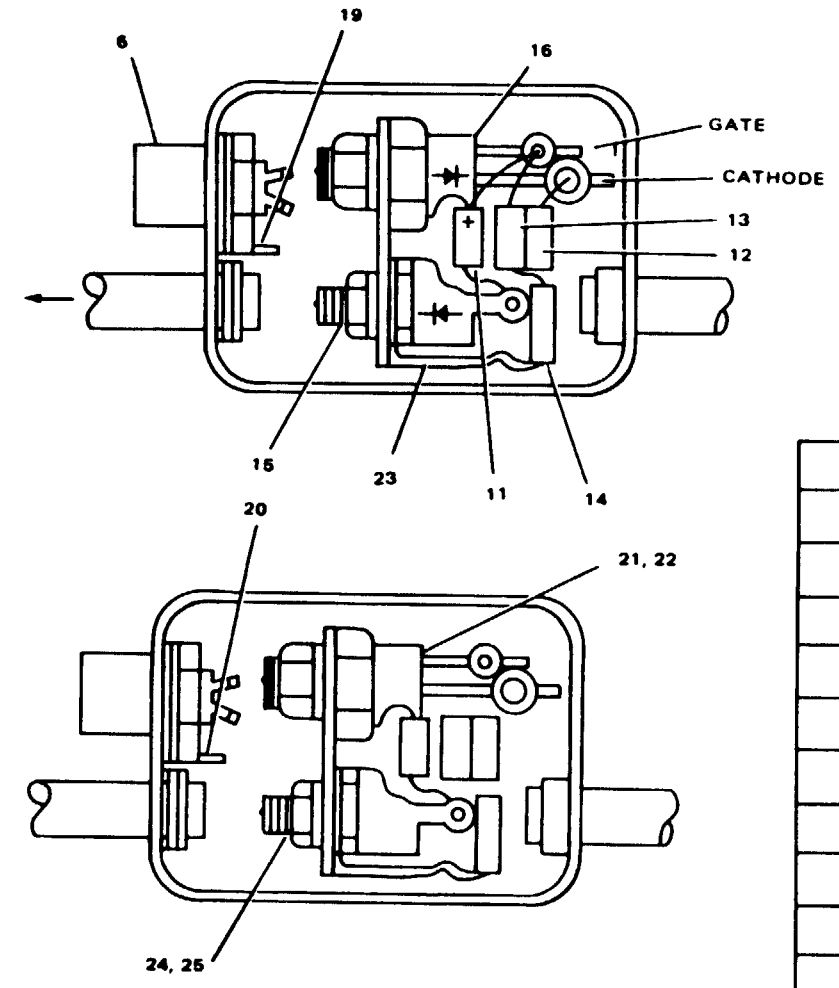

DETAIL A

WIRE LIST	
FROM	TO
J1-2	F1-1
F1-1	E2
F1-2	P1
J1-1	Q1 CATH
Q1 CATH	P2
Q1 CATH	E1
Q1 CATH	CR1 ANODE
C1 +	Q1 GATE
C1 -	CR1 ANODE
R1	Q1 CATH
R1	VR1 ANODE
R2	VR1 ANODE
R2	Q1 GATE
VR1 CATH	E2

**BATTERY EXTENDER CABLE**

ITEM	DESCRIPTION
1	Strap, Cover
2	Thumbscrew
3	Cover, Connector
4	Cover, Junction Box
5	Thumbscrew
6	Cover, Connector
7	Connector
8	Connector, Battery

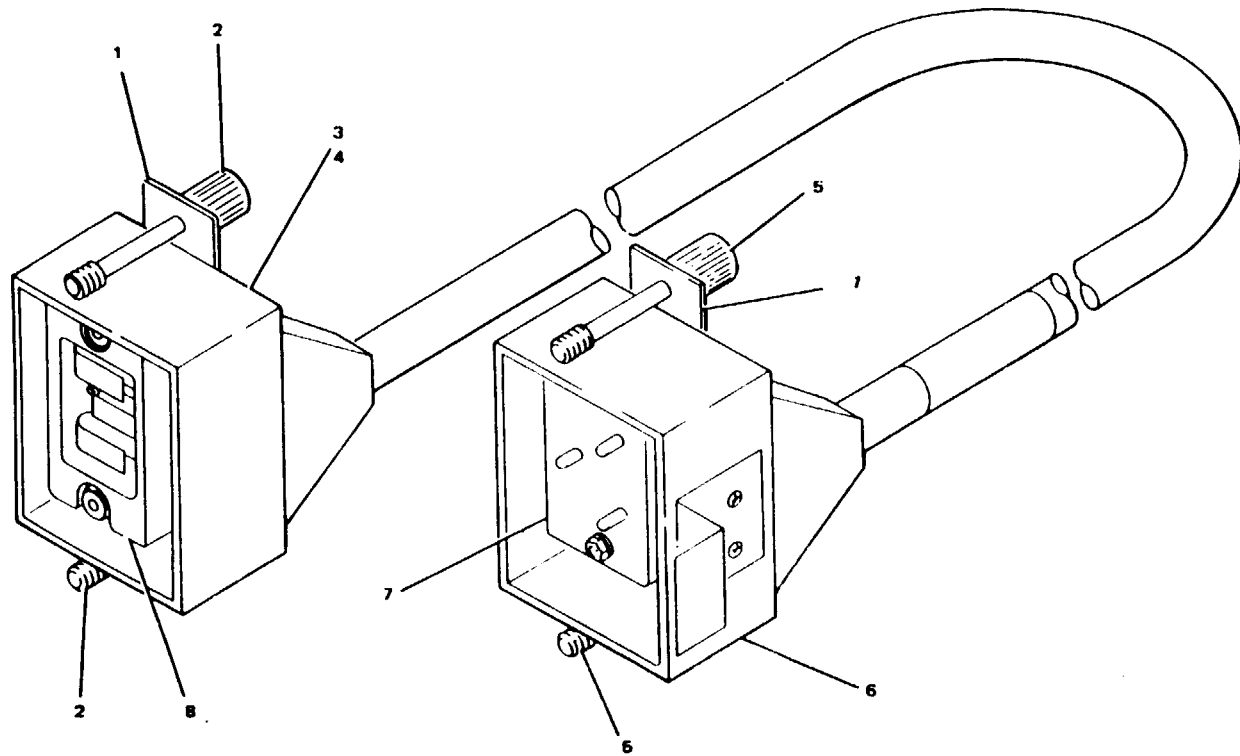

**ANTENNA BASE**

ITEM	DESCRIPTION
1	Antenna Base
2	Connector, Coaxial

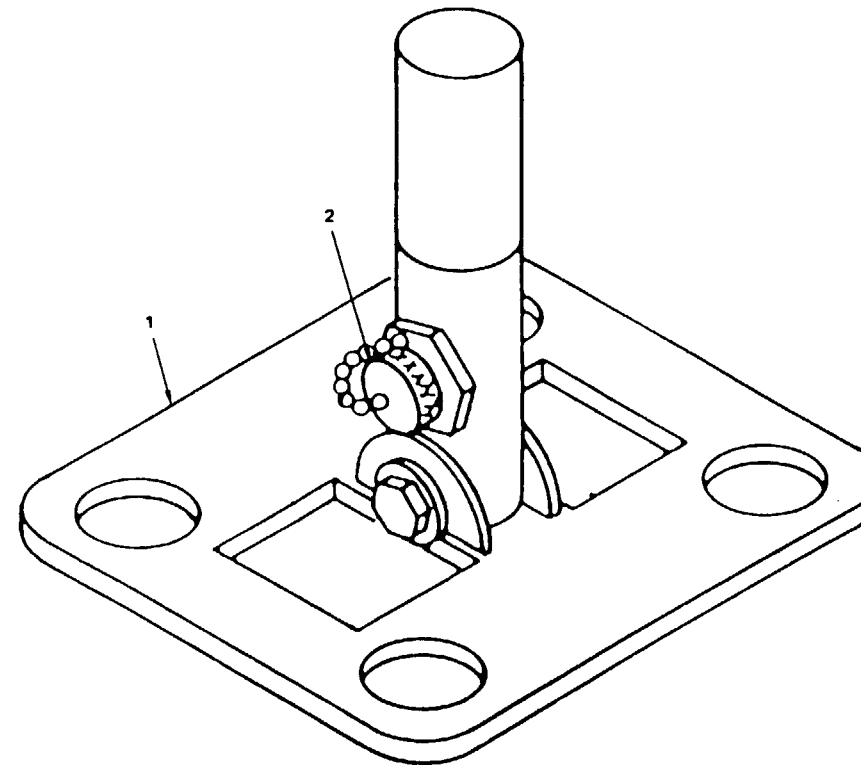

**TELEGRAPH KEY**

ITEM	DESCRIPTION
1	ID Plate
2	Connector
3	Cable Assembly

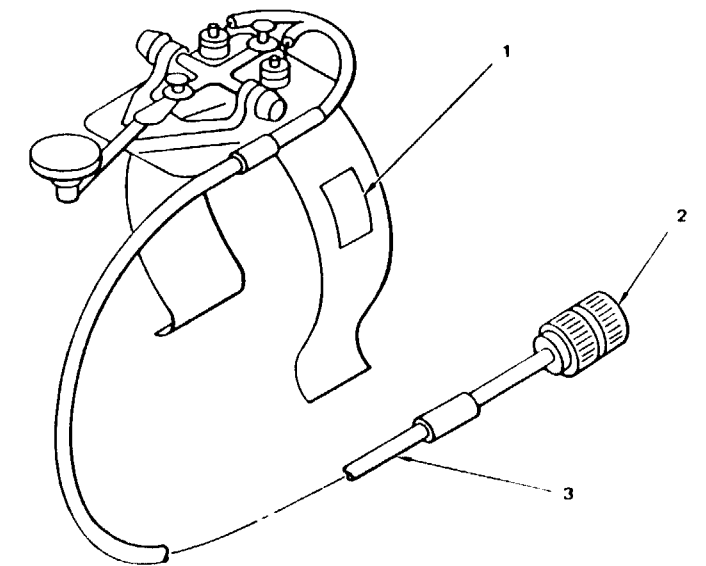

**TRANSIT CASE**

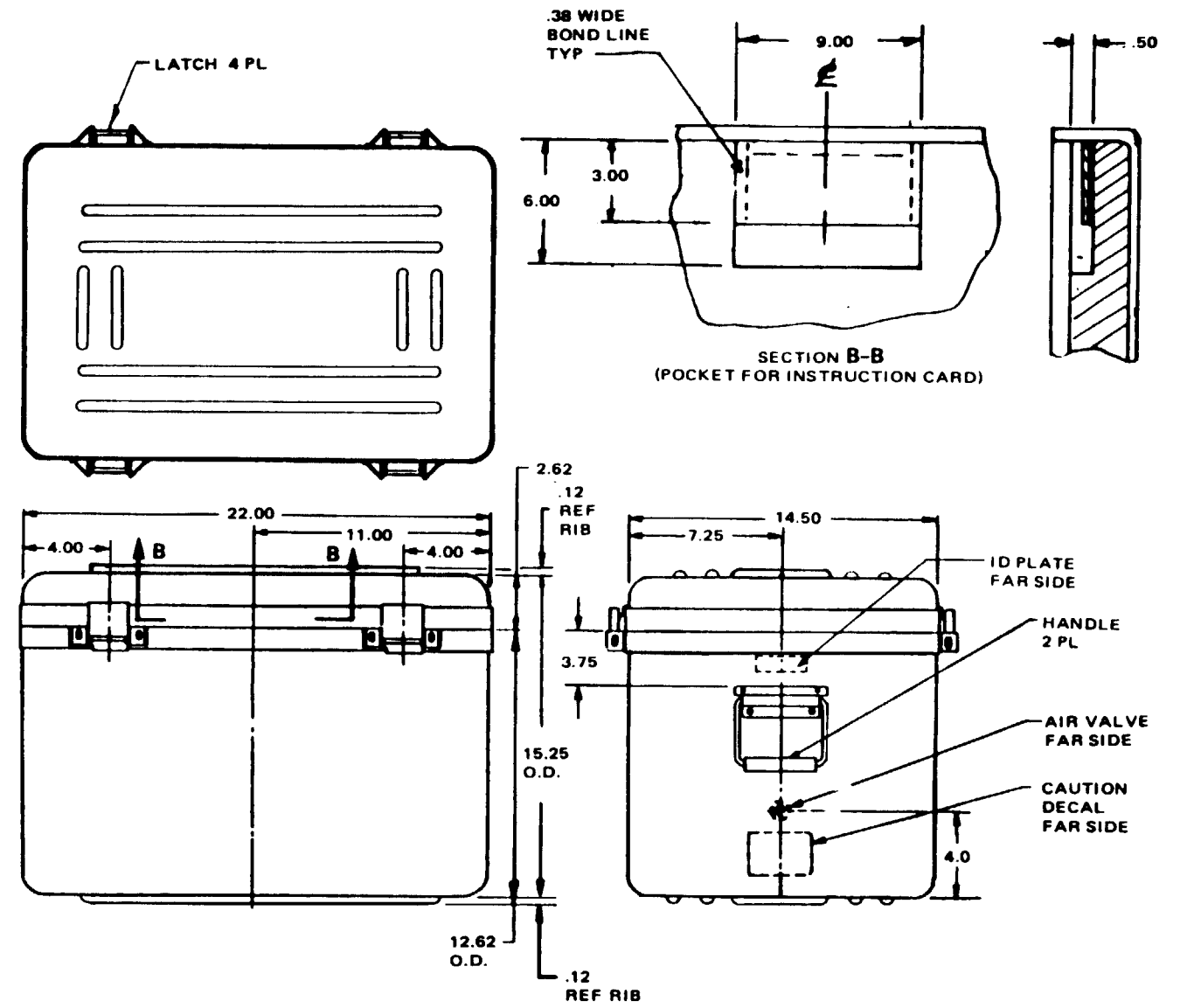
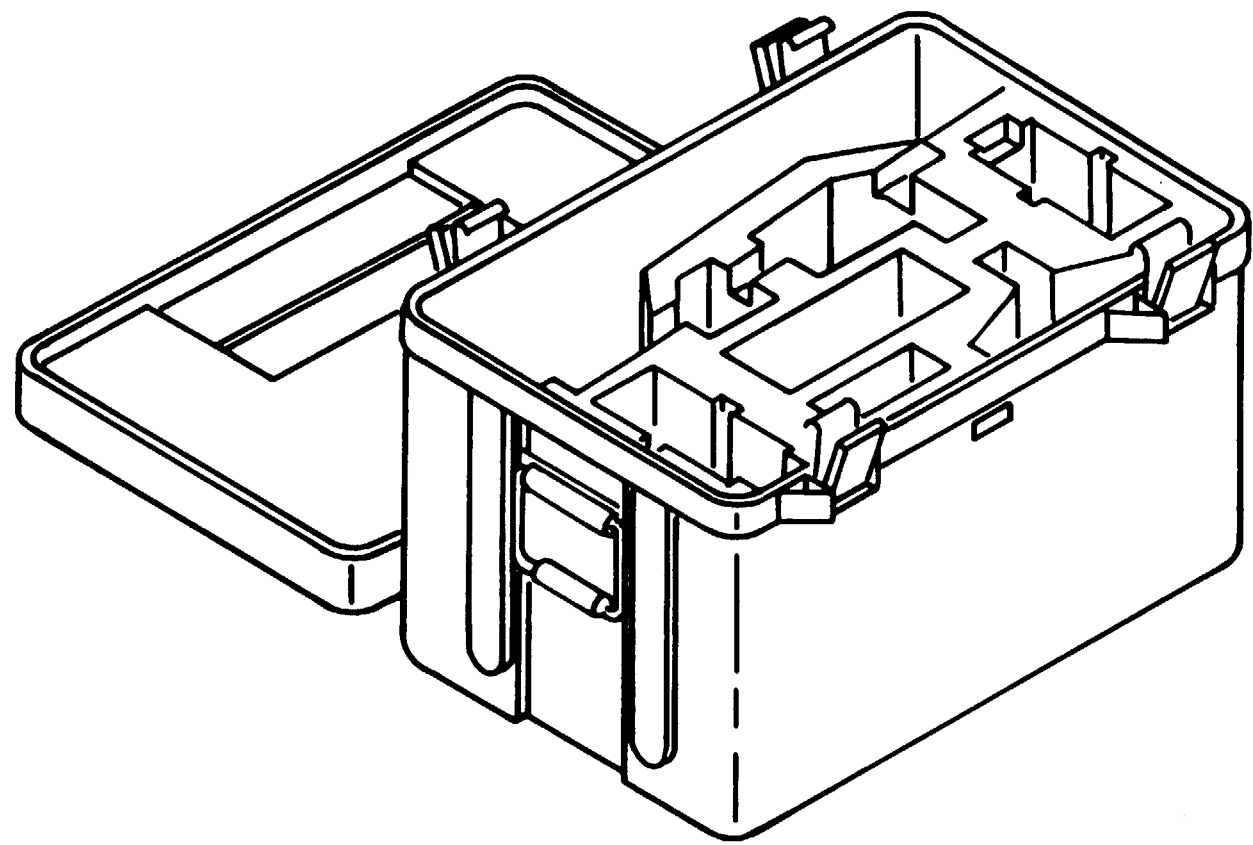

## CHAPTER 4 RT MAINTENANCE

### Section I. TOOLS AND TEST EQUIPMENT

	Page
Introduction .....	4-1
RT Special Tools.....	4-1
RT Test Equipment .....	4-1
Repair Parts and Special Tools .....	4-1

#### INTRODUCTION

This chapter provides the necessary information to maintain the STAJ RT. Information required for the repair of the RT housing and covers is contained in RS-07748A-50/4. The troubleshooting flowchart checks out the RT and aids the maintenance technician in isolating a fault to a module. Disassembly procedures, reassembly procedures, maintenance diagrams, and component locations are also provided.

#### RT SPECIAL TOOLS

The special tools, materials, test cables, and fixtures required for maintenance of the RT are listed in the table below. Tools and materials on pages 3-4 and 3-5 should also be considered when unit repair is required.

Description	Part Number	Quantity
Tool Kit, Electronic Equipment	TK-105/g	1
General Support Maintenance Kit	OA-9163/GRC-213A	1
O-Ring Lubricant	4275140-998 (MIL-S-22473)	AR

#### RT TEST EQUIPMENT

The following table lists the test equipment required to test the RT. Refer to *page 1-6* for equipment characteristics.

#### NOTES

1. Equivalent test equipment may be used.
2. Use only test equipment that is properly calibrated. Failure to do so may provide erroneous or misleading performance or fault indications.
3. If adequate wattmeter is not available, substitute VTVM terminated with dummy load,  $P = E^2/R$ , where  $R = 50$  ohms.

Description	Quantity
DC, Power Supply	1
Detecting Element	1
Dummy Load	1
Generator, Signal	1
Multimeter	1
RF Signal Generator	1
Test Set, Radio Frequency	1

#### REPAIR PARTS AND SPECIAL TOOLS

The repair parts and special tools list is intended for Army use only.

Title	Publication Number
Repair Parts and Special Tools List	TM 11-5820-1046-40P

BLANK  
INTENTIONALLY

Section II. RT TROUBLESHOOTING

	Page
Introduction .....	4-3
Test Setup .....	4-3
RT Troubleshooting Procedure .....	4-4

**INTRODUCTION**

The RT troubleshooting flowchart allows the maintenance technician to isolate a probable fault in the RT. The flowchart should be used with the component location diagrams (chapter 6, section II).. Once a fault has been isolated the disassembly and reassembly procedures in section iii should be used to remove the faulty component.

**TEST SETUP, fig 4-1**

The troubleshooting procedure setup for the RT is shown in the diagram below.

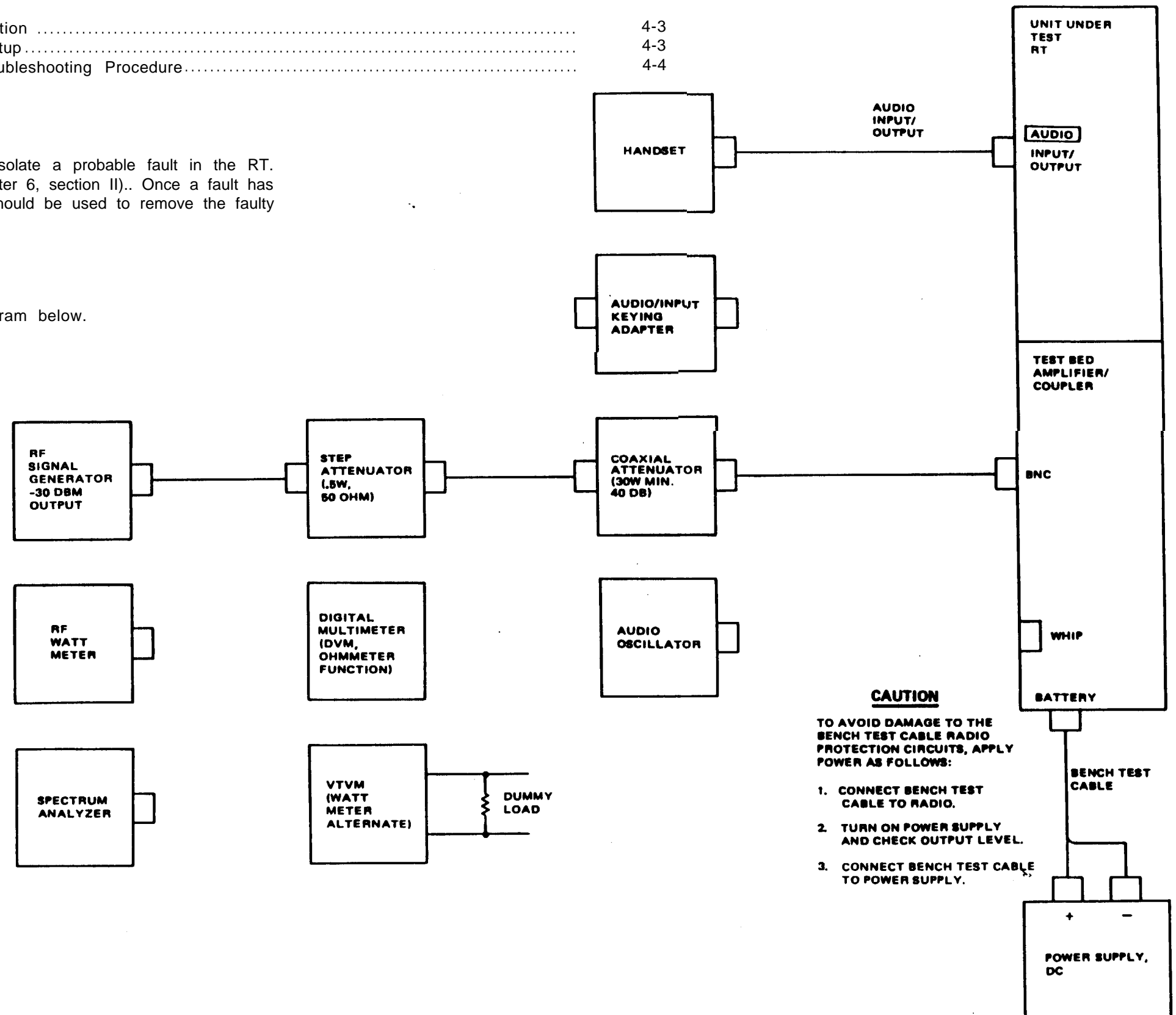

NOTES:

1. EQUIVALENT TEST EQUIPMENT MAY BE USED.
2. USE ONLY TEST EQUIPMENT THAT IS PROPERLY CALIBRATED. FAILURE TO DO SO MAY PROVIDE ERRONEOUS OR MISLEADING PERFORMANCE OR FAULT INDICATIONS.
3. IF ADEQUATE WATTMETER IS NOT AVAILABLE, SUBSTITUTE VTVM TERMINATED WITH DUMMY LOAD,  $P = E^2/R$  WHERE  $R = 50$  OHMS.
4. BEFORE USING SPECTRUM ANALYZER, RF SECTION HP-8553B PERFORM PRELIMINARY CHECKS CONTAINED IN THE HP-8553B OPERATING MANUAL.

Figure 4-1. Test Setup

**RT TROUBLESHOOTING PROCEDURE (1 of 3)**

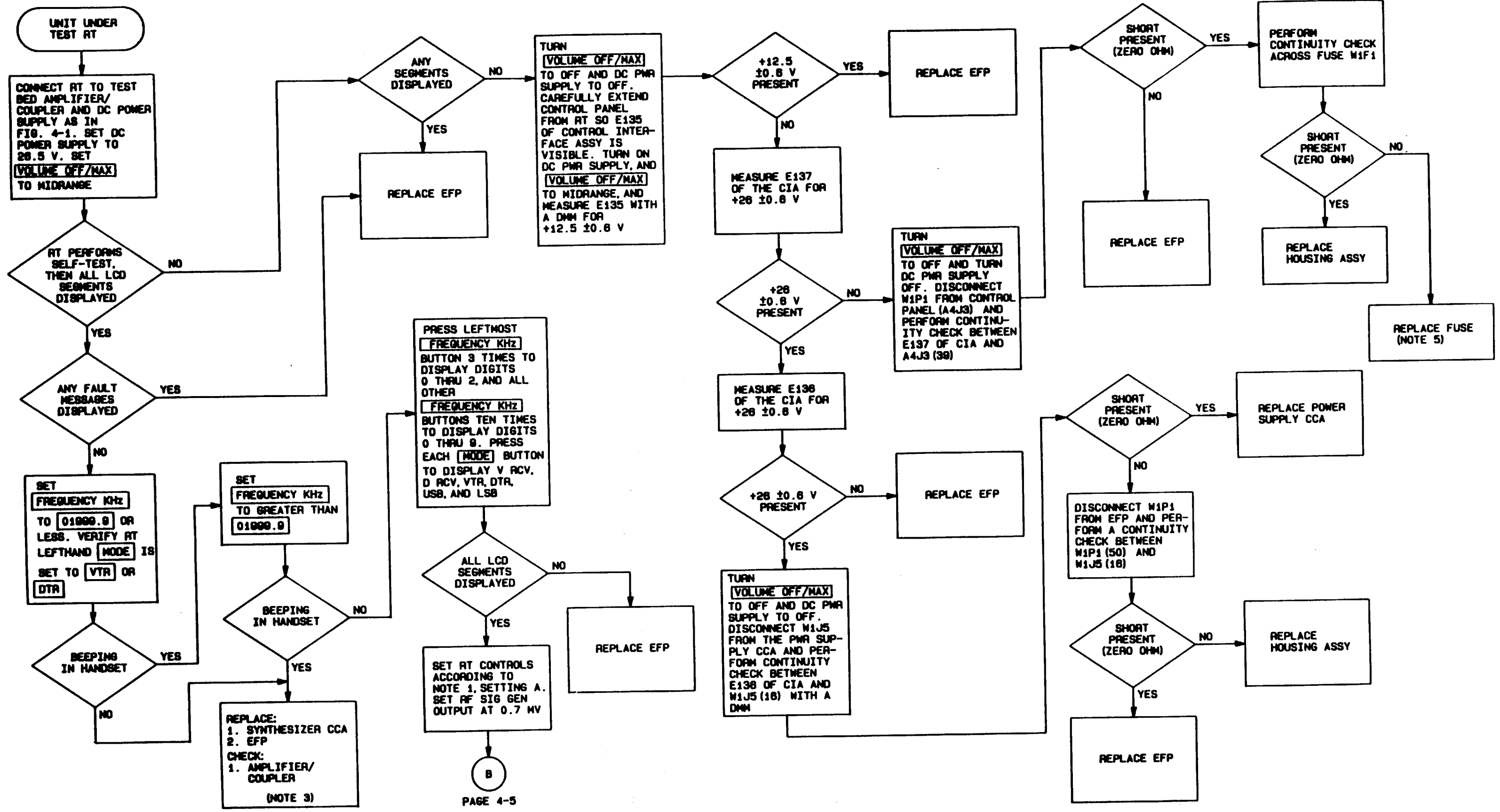



RT TROUBLESHOOTING PROCEDURE (2 of 3)

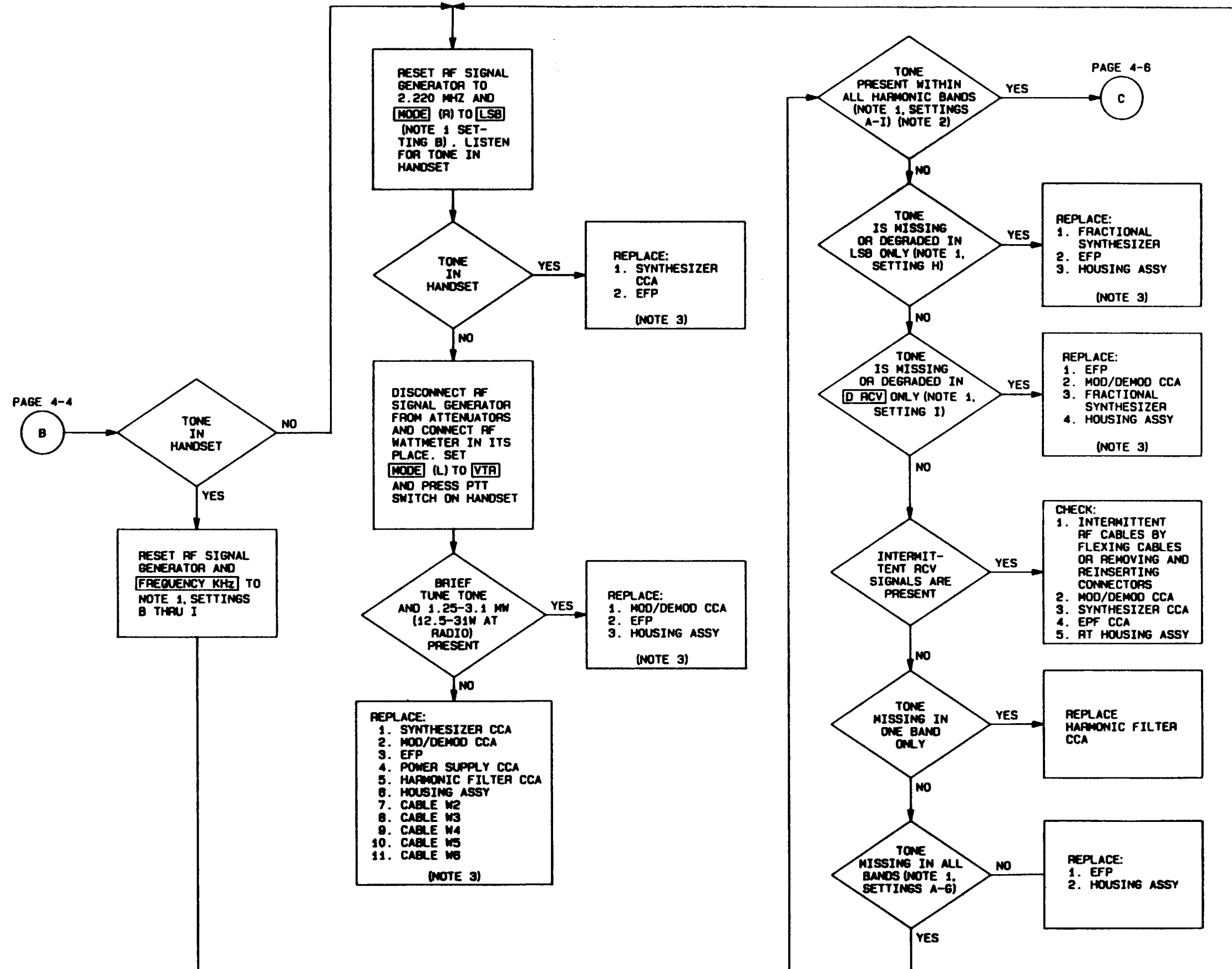

**RT TROUBLESHOOTING PROCEDURE (3 of 3)**

PAGE 4-5

C

DISCONNECT RF SIGNAL GENERATOR FROM ATTENUATORS AND CONNECT WATTMETER IN ITS PLACE. CONNECT AUDIO ADAPTER TO RT. CONNECT AUDIO INPUT/KEYING ADAPTER TO AUDIO ADAPTER. CONNECT HANDSET TO AUDIO ADAPTER.

SET [FREQUENCY KHZ] TO [15,554.5]  
 SET [MODE] (R) TO [USB]  
 [MODE] (L) TO [VTR]  
 CLOSE CW KEY ON AUDIO INPUT/KEYING ADAPTER.

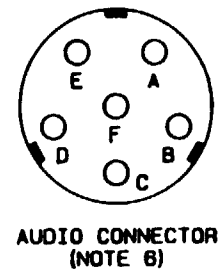
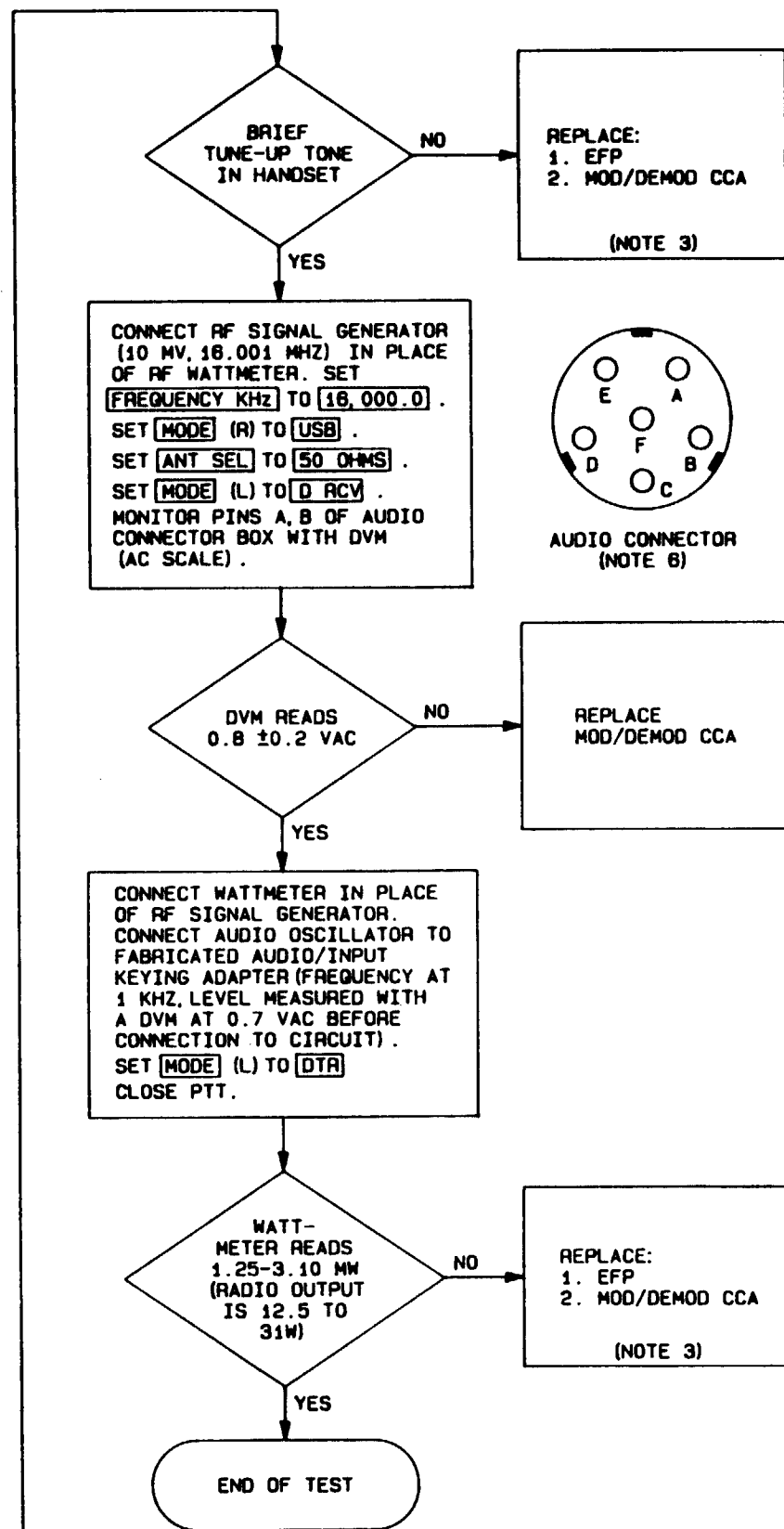
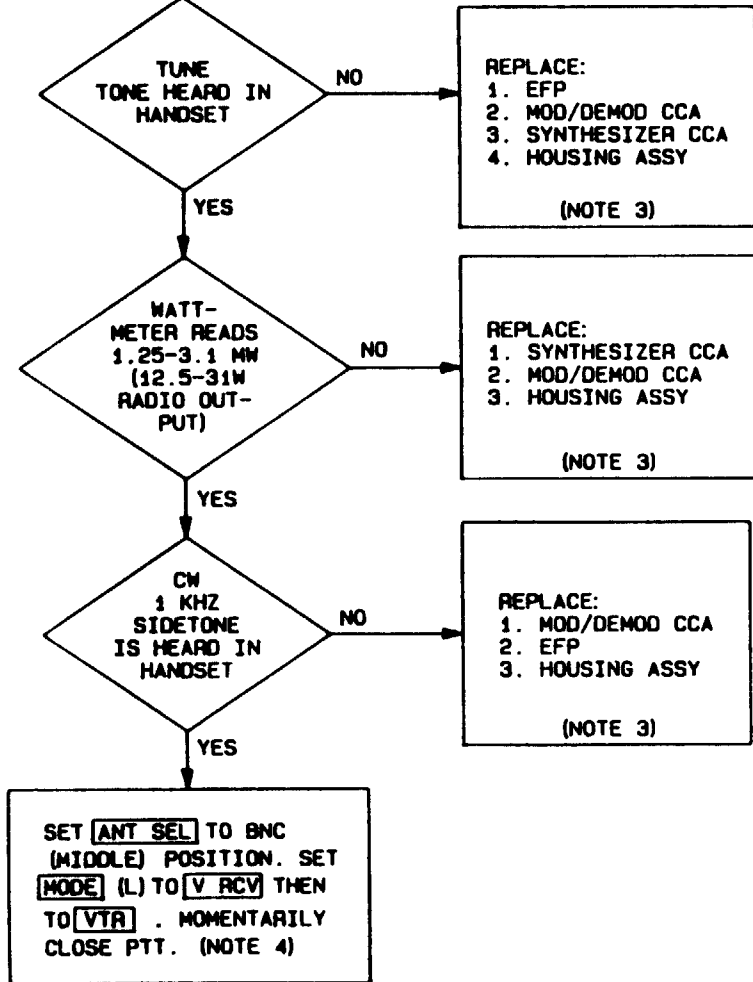

NOTES:

1.	SETTING	RADIO SET FREQUENCY (KHZ)	SIDEBAND	MODE	RF SIGNAL GENERATOR FREQUENCY (MHZ)
	A	2,221.0	USB	V RCV	2.222
	B	2,221.0	LSB	V RCV	2.220
	C	3,334.0	USB	V RCV	3.335
	D	8,885.0	USB	V RCV	8.888
	E	8,888.0	USB	V RCV	8.889
	F	15,554.0	USB	V RCV	15.555
	G	27,777.0	USB	V RCV	27.778
	H	27,777.0	LSB	V RCV	27.776
	I	27,777.0	LSB	D RCV	27.778

- HARMONIC BANDS ARE 2-3 MHZ, 3-5 MHZ, 5-8 MHZ, 8-12 MHZ, 12-20 MHZ, AND 20-30 MHZ.
- REINSTALL THE ORIGINAL MODULES IN REVERSE ORDER. IF THEY DID NOT CORRECT THE FAULT, THEY ARE GOOD MODULES AND SHOULD NOT BE CONDEMNED AS FAULTY.
- FREQUENCY OR MODE MUST BE CHANGED EACH TIME TO CAUSE TUNE-UP TONE. WHEN PTT IS CLOSED. SETTING THE MODE SWITCH TO V-RCV AND BACK TO V-TR WILL GENERATE A TUNE START PULSE. THIS, IN TURN, ALLOWS A TUNE CYCLE TO START WHEN PTT IS PRESSED. CHANGING ANY FREQUENCY DIGIT EXCEPT 100 HZ OR TURNING THE RADIO SET OFF AND BACK ON WILL ALSO GENERATE A TUNE START PULSE.
- IF THE FUSE OPENS AGAIN DURING TESTING, REPLACE THE FOLLOWING UNTIL THE FAULT IS CORRECTED:
  - POWER SUPPLY CCA
  - ELECTRONIC FRONT PANEL (EFP)
  - SYNTHESIZER CCA
  - MOD/DEMOD CCA
  - HARMONIC FILTER CCA
  - HOUSING ASSY

8.	AUDIO CONNECTOR PIN	SIGNAL NAME
	A	AUDIO RTN
	B	RCV AUDIO
	C	PTT
	D	XMT AUDIO
	E	CW KEY
	F	CTS

**Section III. RT DISASSEMBLY AND REASSEMBLY**

	Page		Page
Introduction .....	4-7	Cable W1 Removal and Replacement .....	4-15
RT Disassembly and Reassembly .....	4-7	Cable W2 Removal and Replacement .....	4-16
RT Housing Assembly Removal and Replacement .....	4-8	Cable W3 Removal and Replacement .....	4-17
Modulator/Demodulator A1A1 Removal and Replacement .....	4-9	Cable W4 Removal and Replacement .....	4-17
Harmonic Filter A1A2 Removal and Replacement .....	4-11	Cable W5 Removal and Replacement .....	4-18
Synthesizer A1A3 Removal and Replacement .....	4-12	Cable W6 Removal and Replacement .....	4-19
Electronic Front Panel (EFP) A1A4 Removal and Replacement .....	4-13	Electronic Front Panel (EFP) A1A4 Detailed Removal and Replacement .....	4-21
Power Supply A1A5 Removal and Replacement .....	4-14		

**INTRODUCTION**

Once a fault has been isolated, the disassembly and reassembly procedures in this section should be used to remove the faulty RT component. Component location diagrams are provided in this section for easy reference. Refer to the tables in section I of this chapter for necessary tools and test equipment.

**RT DISASSEMBLY AND REASSEMBLY**

Procedures for disassembly and reassembly of the RT (A1) consist of removing and replacing the following modules:

- RT Housing
- Modulator/Demodulator (A1A1)
- Harmonic Filter (A1A2)
- Synthesizer (A1A3)
- Electronic Front Panel (A1A4)
- Power Supply (A1A5)
- Cables W1 thru W6

**RT HOUSING ASSEMBLY REMOVAL AND REPLACEMENT**

**INITIAL SETUP**

Tools	Materials/Parts:	Personnel Required:
Tool Kit, Electronic Equipment General Support Maintenance Kit	None	1

**WARNING**

De-energize equipment before removing or replacing the RT housing assembly.

**CAUTION**

Use ESD precautionary procedures when handling, removing, or replacing modules or cables.

**REMOVAL**

**NOTE**

This procedure is performed when cable W1 is defective.

**CAUTION**

When removing modules (except for power supply), pull straight up. Do not rock.

Perform module removal procedures for the following:

- Modulator/Demodulator A1A1 Removal (page 4-9)
- Harmonic Filter A1A2 Removal (page 4-11)
- Synthesizer A1A3 Removal (page 4-12)
- Electronic Front Panel (EFP) A1A4 Removal (page 4-13)
- Power Supply A1A5 Removal (page 4-14)

**CAUTION**

Use extreme care when removing cables. Creasing or severe bending will damage cables internally.

2. Perform cable removal procedures for cables W1 thru W6 (pages 4-75 thru 4-19)

**REPLACEMENT**

**NOTE**

This procedure is performed when cable W1 is replaced by depot level maintenance.

**CAUTION**

When removing modules (except for power supply), pull straight up. Do not rock.

1. Perform module replacement procedures for the following:

- Power Supply A1A5 Replacement (page 4-14)
- EFP A1A4 Replacement (page 4-13)
- Synthesizer A1A3 Replacement (page 4-12)
- Harmonic Filter A1A2 Replacement (page 4-11)
- Modulator/Demodulator A1A1 Replacement (page 4-9)

**CAUTION**

Use extreme care when replacing cables. Creasing or severe bending will damage cables internally.

2. Perform cable replacement procedures for cables W1 thru W6 (pages 4-15 thru 4-19).

**MODULATOR/DEMODULATOR A1A1 REMOVAL AND REPLACEMENT (1 of 2), fig 4-2**

**INITIAL SETUP**

**Tools:**

Tool Kit, Electronic Equipment  
General Support Maintenance Kit

**Materials/Parts:**

None

**Personnel Required**

1

**WARNING**

De-energize equipment before removing or replacing the modulator/demodulator.

**CAUTION**

Use ESD precautionary procedures when handling, removing, or replacing the modulator/demodulator.

**REMOVAL**

1. Place RT so cover assembly (1) is on top and, when facing electronic front panel, control knobs read right side up.
2. Remove cover assembly (1) by loosening 8 captive screws (2).
3. Disconnect 4 color-coded rf cables (13) from modulator/demodulator (15).
4. Disconnect 2 color-coded rf cables (6) from harmonic filter module (4).
5. Loosen 4 captive screws (16) on modulator/demodulator module (15).
6. Move and hold rf cables away from module.

**CAUTION**

Care should be taken in lifting modulator/demodulator (15) from RT housing (7). 10-pin connector cable (19) is attached underneath modulator/demodulator (15).

7. Grasp nylon line handle on top of modulator/demodulator module (15) closer to back end of RT and pull gently upward to remove module from RT housing (7).
8. Loosen hex screw in wire bundle on 10-pin connector (17) using correct size hex key.
9. Remove 10-pin connector (17).
10. Remove rf cable (14) W6P2 from module (15).

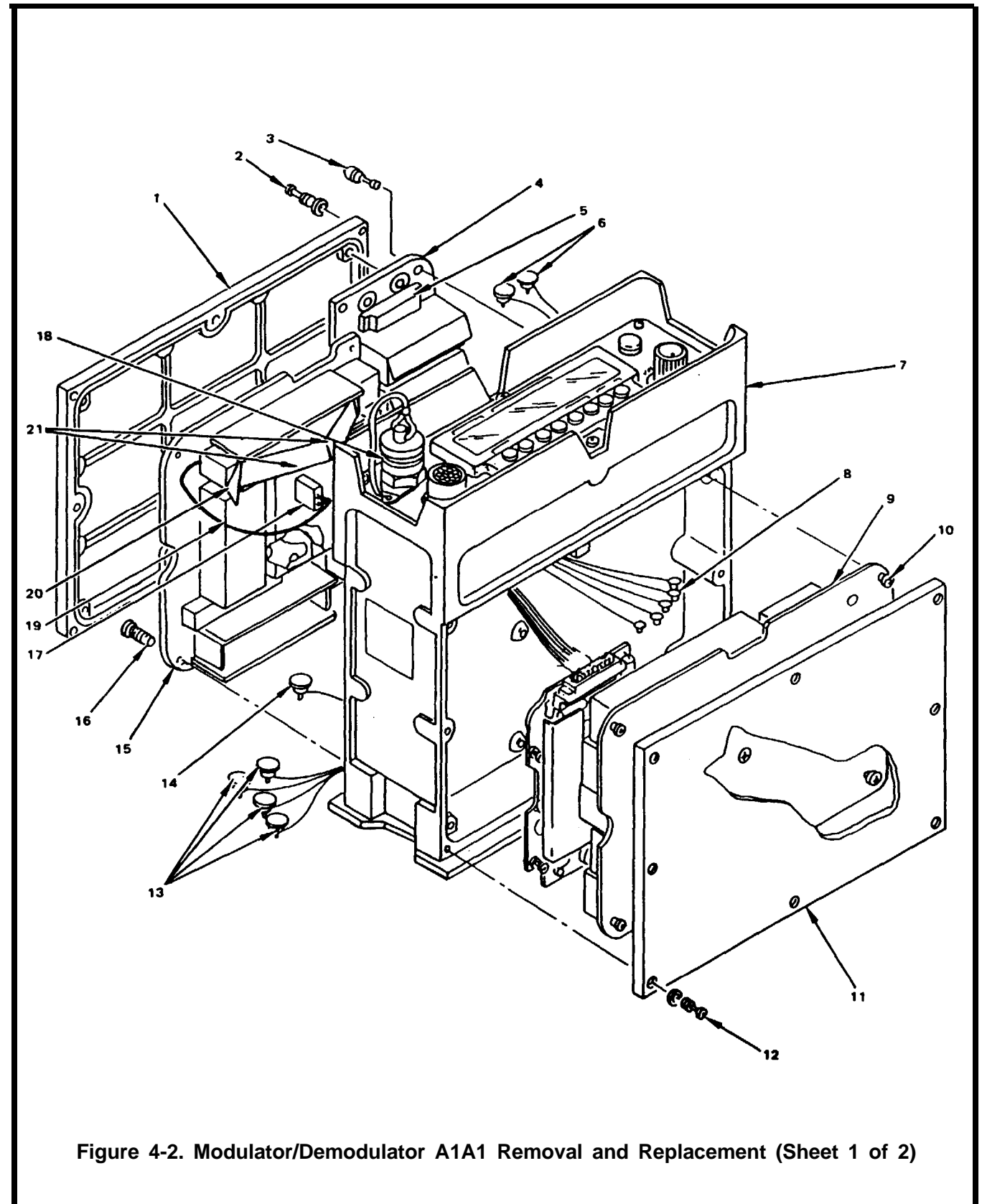

Figure 4-2. Modulator/Demodulator A1A1 Removal and Replacement (Sheet 1 of 2)

**MODULATOR/DEMODULATOR A1A1 REMOVAL AND REPLACEMENT (2 of 2), fig 4-2**

**REPLACEMENT**

1. Replace 10-pin connector (17) and tighten screw using correct size hex key.
2. Reconnect rf cable W6P2 (14).

**CAUTION**

Care should be taken in placement of 10-pin connector cable W6 (19) when placing module into RT housing (7). Ensure cable W6 (19) rests under cable retainer spring (20).

3. Hold rf cables back so as not to interfere with modulator/demodulator module (15) placement.
4. Ensure cable W6 (19) rests under cable retainer spring (20) and no cables are crushed by spring fingers. Carefully push module into RT housing (7) so multipin connector (18) fits properly into jack in RT housing.
5. Tighten 4 captive screws (16) on modulator/demodulator module (15).
6. Reconnect 4 color-coded rf cables (13) to modulator/demodulator module (15).
7. Reconnect 2 color-coded rf cables (6) to harmonic filter module (4).

**NOTE**

Verify rf connectors are seated properly into CCA.

8. Inspect and lubricate O-ring in cover assembly (1).
9. Replace cover assembly (1) and tighten 8 screws (2).

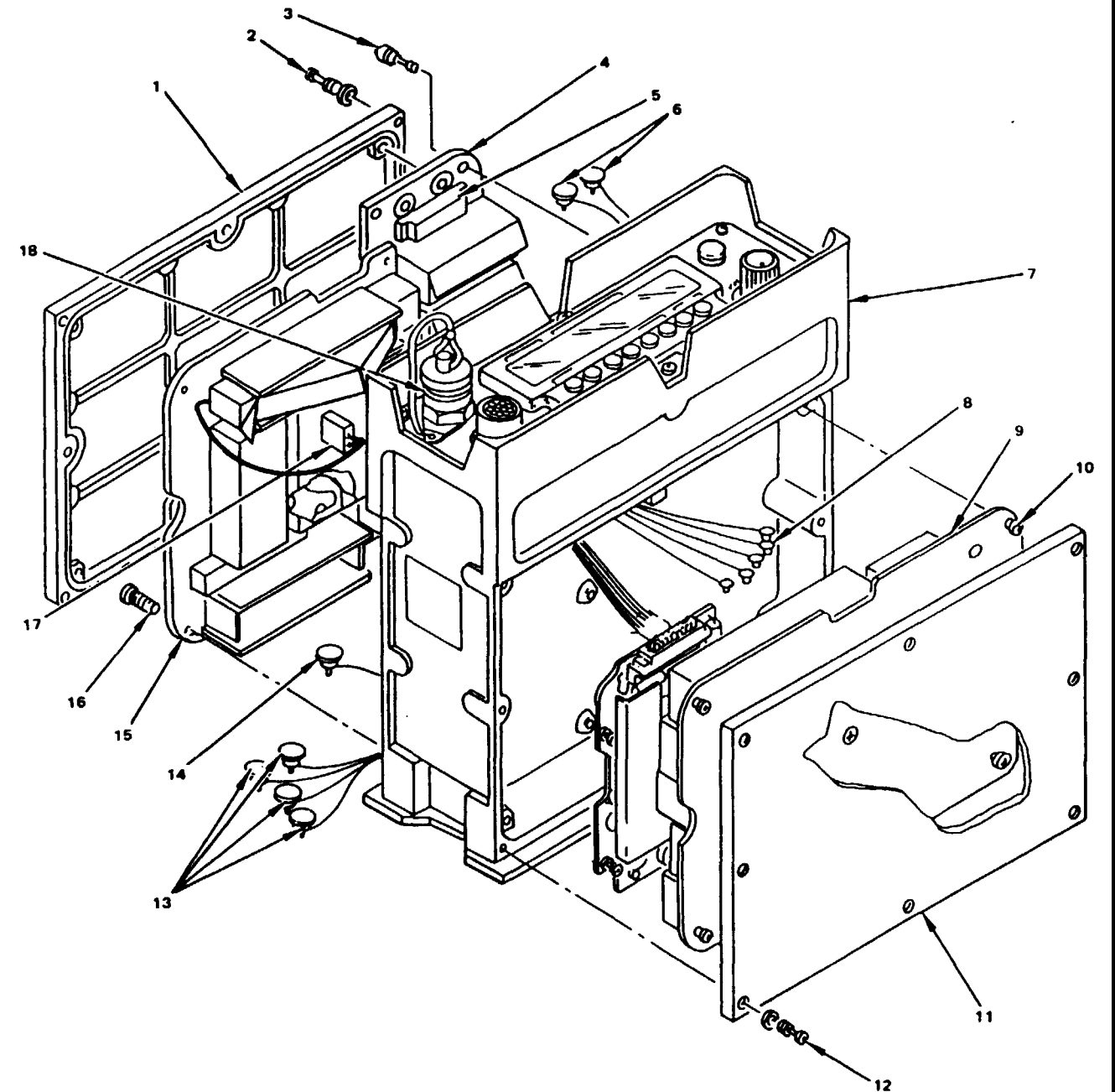

Figure 4-2. Modulator/Demodulator A1A1 Removal and Replacement (Sheet 2 of 2)

**HARMONIC FILTER A1A2 REMOVAL AND REPLACEMENT, fig 4-3**

**INITIAL SETUP**

Tools:	Materials/Parts:	Personnel Required
Tool Kit, Electronic Equipment General Support Maintenance Kit	None	1

**WARNING**

De-energize equipment before removing or replacing the harmonic filter.

**CAUTION**

Use ESD precautionary procedures when handling, removing, or replacing the harmonic filter.

**REMOVAL**

1. Place RT so cover assembly (1) is on top and electronic front panel and control knobs read rightside up.
- 2 Remove cover assembly (1) by loosening 8 captive screws (2).
3. Disconnect 2 color-coded rf cables (6) from harmonic filter module (4).
4. Loosen 4 captive screws (3) on harmonic filter module (4).
5. Grasp nylon line handle on top of harmonic filter module (4) and pull gently upward to remove module.

**REPLACEMENT**

1. Align harmonic filter module (4) over RT housing connector (not shown).
- 2 Carefully push module into RT housing, so multipin connector (5) and jack fit properly.
3. Tighten 4 captive screws (3) on harmonic filter module (4).
4. Reconnect 2 rf cables (6) to harmonic filter module (4) according to the color code.
5. Replace cover assembly (1) and tighten 8 captive screws (2).

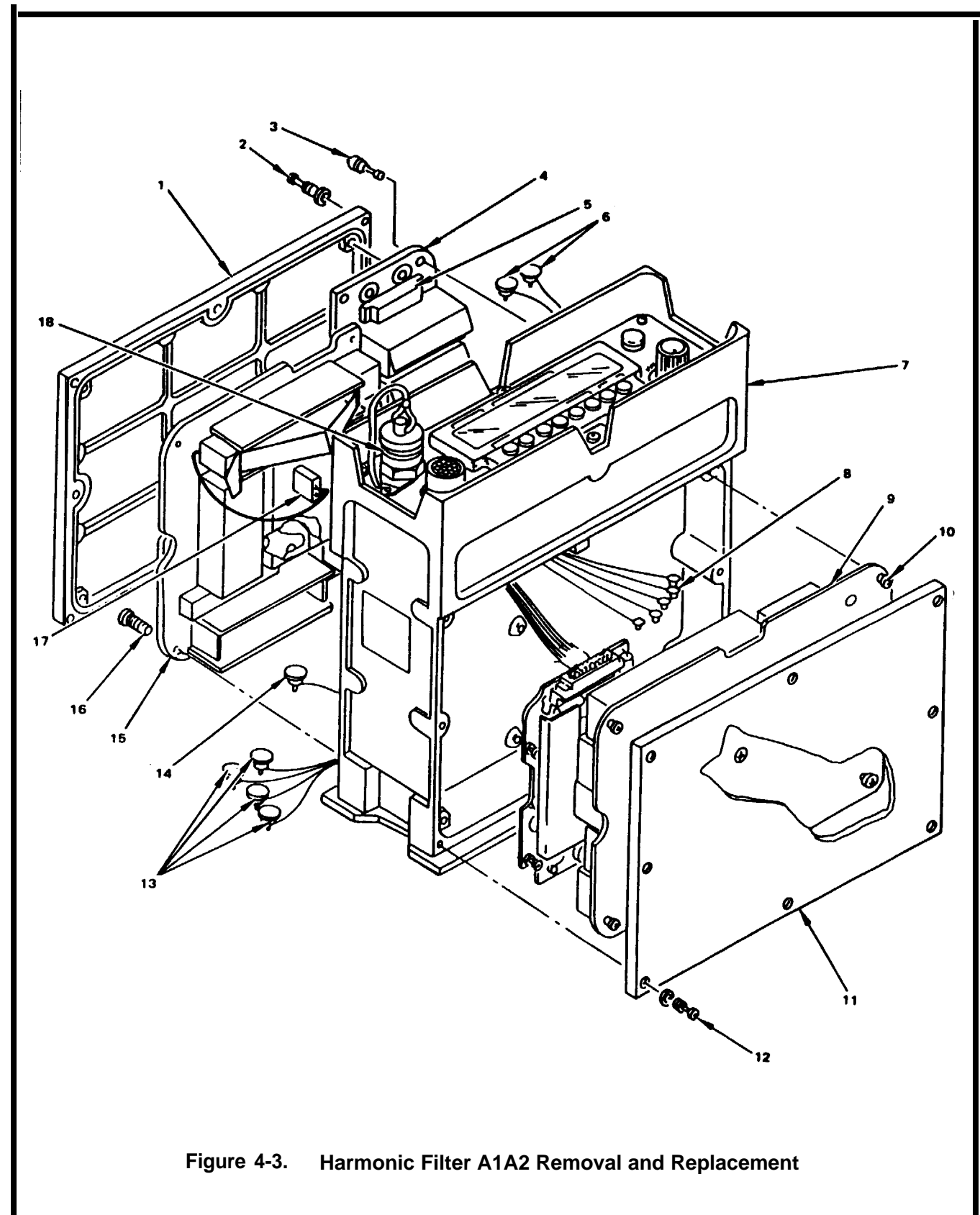

Figure 4-3. Harmonic Filter A1A2 Removal and Replacement

INITIAL SETUP	Tools:	Materials/Parts:	Personnel Required
	Tool Kit, Electronic Equipment General Support Maintenance Kit O-Ring Lubricant	None	1
<b>WARNING</b>			
De-energize equipment before removing or replacing the synthesizer.			
<b>CAUTION</b>			
Use ESD precautionary procedures when handling, removing, or replacing the synthesizer.			
REMOVAL			
<ol style="list-style-type: none"> <li>1. Place RT so bottom cover assembly (11) is on top and control panel is facing away from you.</li> <li>2. Remove cover assembly (11) by loosening 8 captive screws (12).</li> <li>3. Disconnect 5 color-coded rf cables (8) from synthesizer module (9).</li> <li>4. Loosen 5 screws (10) on synthesizer module (9).</li> <li>5. Grasp nylon line handle on module (9) and pull gently upward to remove module.</li> </ol>			
REPLACEMENT			
<ol style="list-style-type: none"> <li>1. Align synthesizer module (9) over multipin connector at bottom of RT housing (7).</li> </ol>			
<b>CAUTION</b>			
When replacing modules, do not pinch rf cables between housing and module.			
<ol style="list-style-type: none"> <li>2. Carefully push module into RT housing (7) so multipin connector (not shown) and jack fit properly.</li> <li>3. Tighten 5 captive screws (10) on module.</li> </ol>			
<b>CAUTION</b>			
Insertion of miniature coax connectors must be made carefully without forcing.			
<ol style="list-style-type: none"> <li>4. Reconnect rf cables (8) to module (9) according to color code. Verify rf cables are properly seated into module.</li> <li>5. Lubricate O-ring in cover assembly (11). Replace cover assembly (11) and tighten 8 captive screws (12).</li> </ol>			

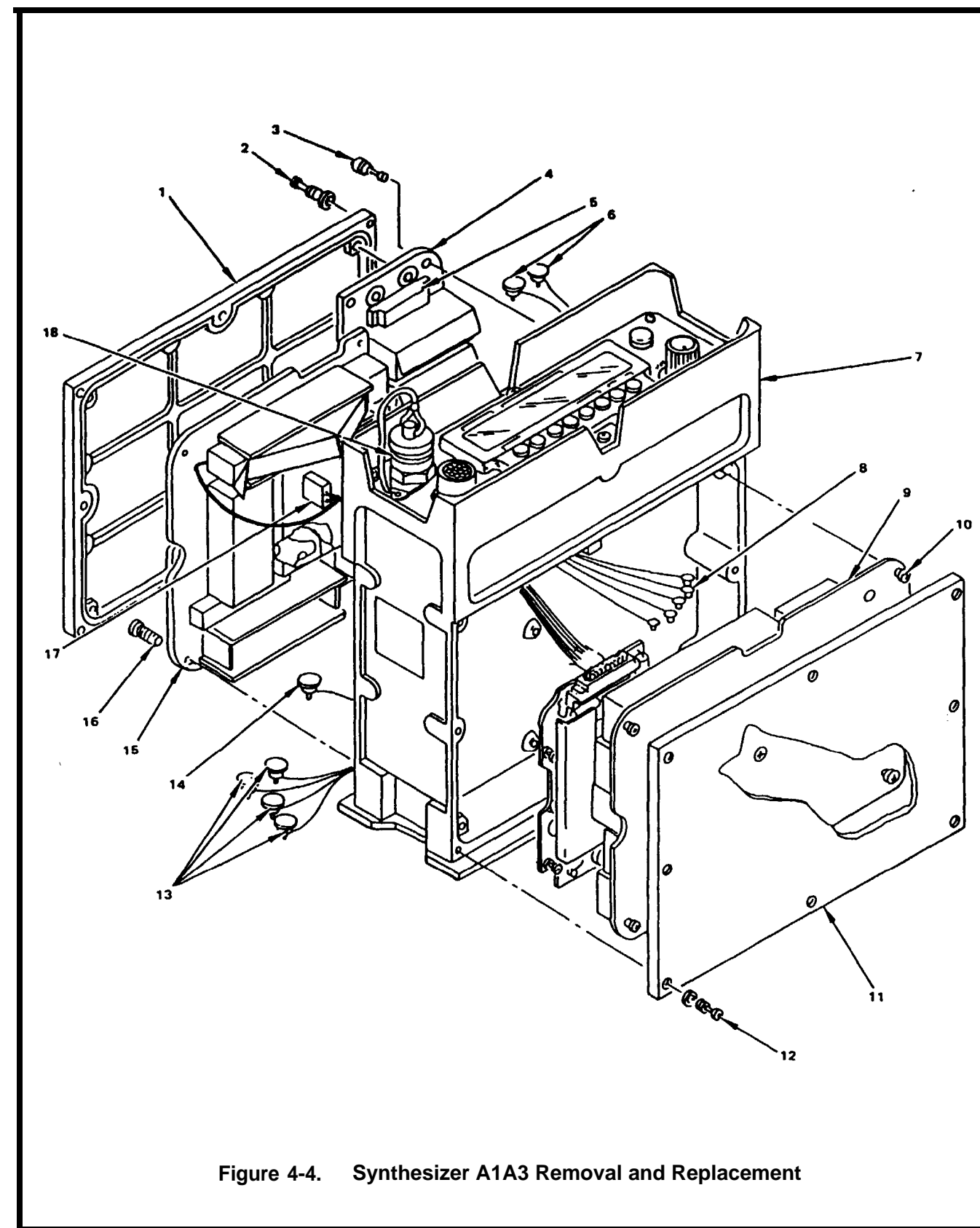

Figure 4-4. Synthesizer A1A3 Removal and Replacement



**ELECTRONIC FRONT PANEL (EFP) A1A4 REMOVAL AND REPLACEMENT, fig 4-5**

**Tools:**

Tool Kit, Electronic Equipment  
General Support Maintenance Kit

**Materials/Parts:**

None

**Personnel Required:**

1

**WARNING**

De-energize equipment before removing or replacing the EFP.

**CAUTION**

Use ESD precautionary procedures when handling, removing, or replacing the EFP.

**REMOVAL**

1. Place RT so EFP cover assembly (4) is on top.
2. Loosen 6 captive screws (3) on EFP cover assembly (4).

**CAUTION**

Care should be taken in lifting EFP (4) from RT housing (6). Attached cables are located underneath EFP (4).

3. Pull EFP (4) out by grasping audio connector plug (2) and display switch assembly (15).
4. Locate 10-pin connector (12) and ribbon cable (14).
5. Loosen captive hex screw on 10-pin connector (12) located on bottom of control interface CCA (1) using correct size hex key. Disconnect 10-pin connector (12).
6. Remove rf cable W5 (6) from control interface CCA (1).
7. Loosen 2 captive hex screws (7) using correct size hex key.
8. Pull ribbon cable plug (10) and multipin connector (5) apart.

**REPLACEMENT**

1. Align ribbon cable plug (10) with multipin connector PI (5) and push them together to seat firmly.

**CAUTION**

Use only moderate force to tighten screws that hold down modules, covers, etc.

2. Tighten 2 captive hex screws (7) using appropriate hex key.
3. Align 10-pin connector (12) to control interface CCA (1) and tighten hex screw using correct size hex key.
4. Connect rf cable W5 (6) to control interface CCA (1).
5. Rest cable W6 (13) on top of ribbon cable (14) forming an s-shape across ribbon cable (14). Put EFP back in RT housing (6) ensuring not to crush any cables. Verify gasket (not shown) is in place.
6. Tighten 6 captive screws (3) on EFP cover assembly (4).

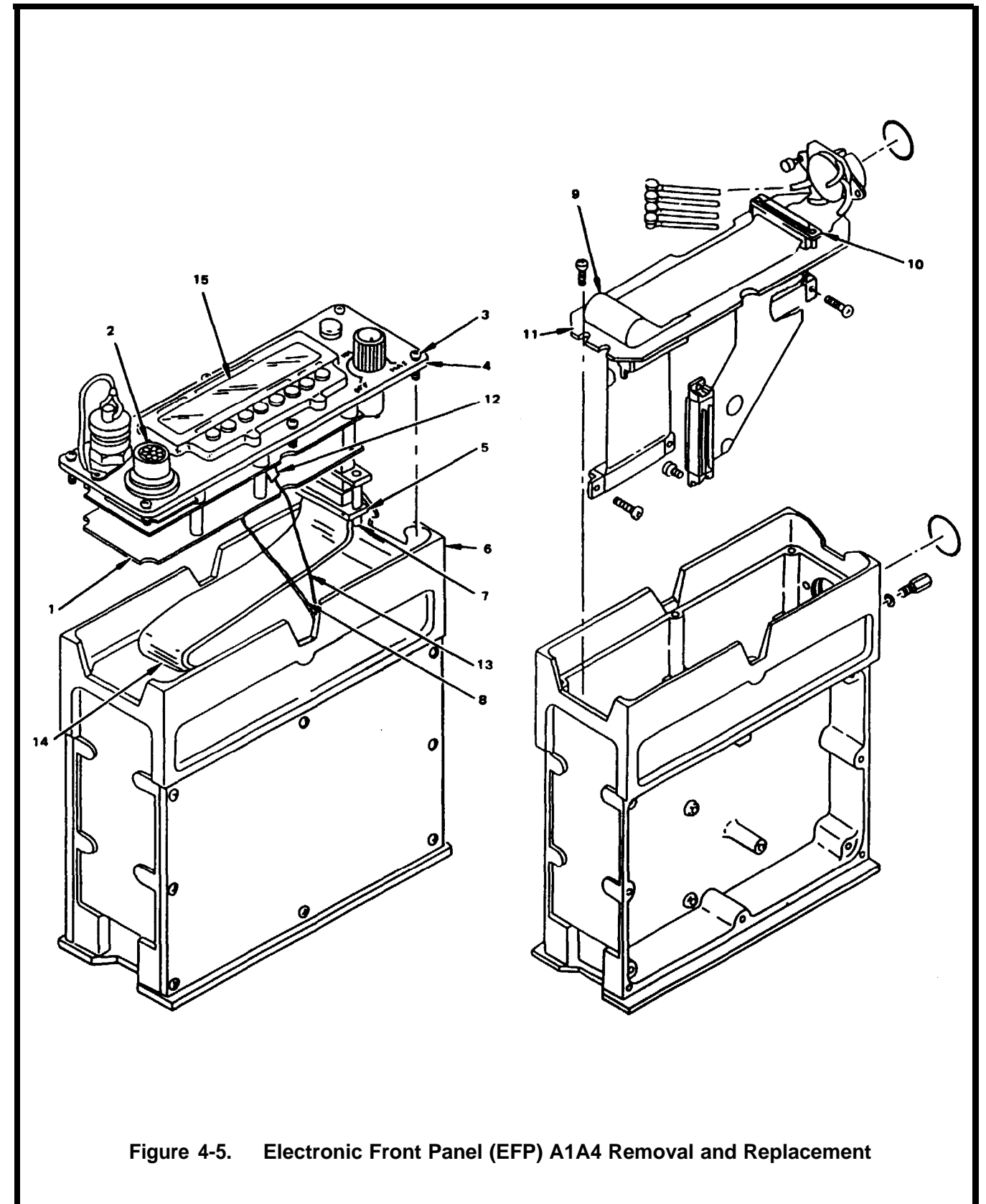

Figure 4-5. Electronic Front Panel (EFP) A1A4 Removal and Replacement

**POWER SUPPLY A1A5 REMOVAL AND REPLACEMENT, fig 4-6**

**INITIAL SETUP**

Tools:	Materials/Parts:	Personnel Required:
Tool Kit, Electronic Equipment General Support Maintenance Kit	None	1

**WARNING**

De-energize equipment before removing or replacing the power supply.

**CAUTION**

Use ESD precautionary procedures when handling, removing, or replacing the power supply.

**REMOVAL**

1. To remove power supply module (4), synthesizer module (2) must first be removed. Remove synthesizer (2) CCA, by performing procedures per Synthesizer A1A3 Removal (page 4-12).
2. Remove 4 captive screws (3) holding power supply module (4) and shield to RT housing (1).

**CAUTION**

Improper removal of power supply may cause damage to multipin connector. If any captive screws begin to tip while removing power supply, stop pulling and straighten screws before proceeding.

3. Grasp nylon line handle and gently ease module (4) and shield backwards out of plug before lifting upward.
4. Loosen 5 captive screws (not shown) connecting shield to power supply.
5. Remove shield.

**REPLACEMENT**

1. Replace shield and tighten 5 screws (not shown) using correct size hex key.
2. Place module so multipin connector PI (5) and jack on RT housing (1) are aligned. Carefully plug module into housing. Pry from back end of module with a screwdriver or other tool, if necessary, to mate connector.
3. Tighten 4 captive screws (3) on power supply module (4).
4. Replace synthesizer (2) CCA, by performing procedures per Synthesizer A1A3 Replacement (page 4-12).

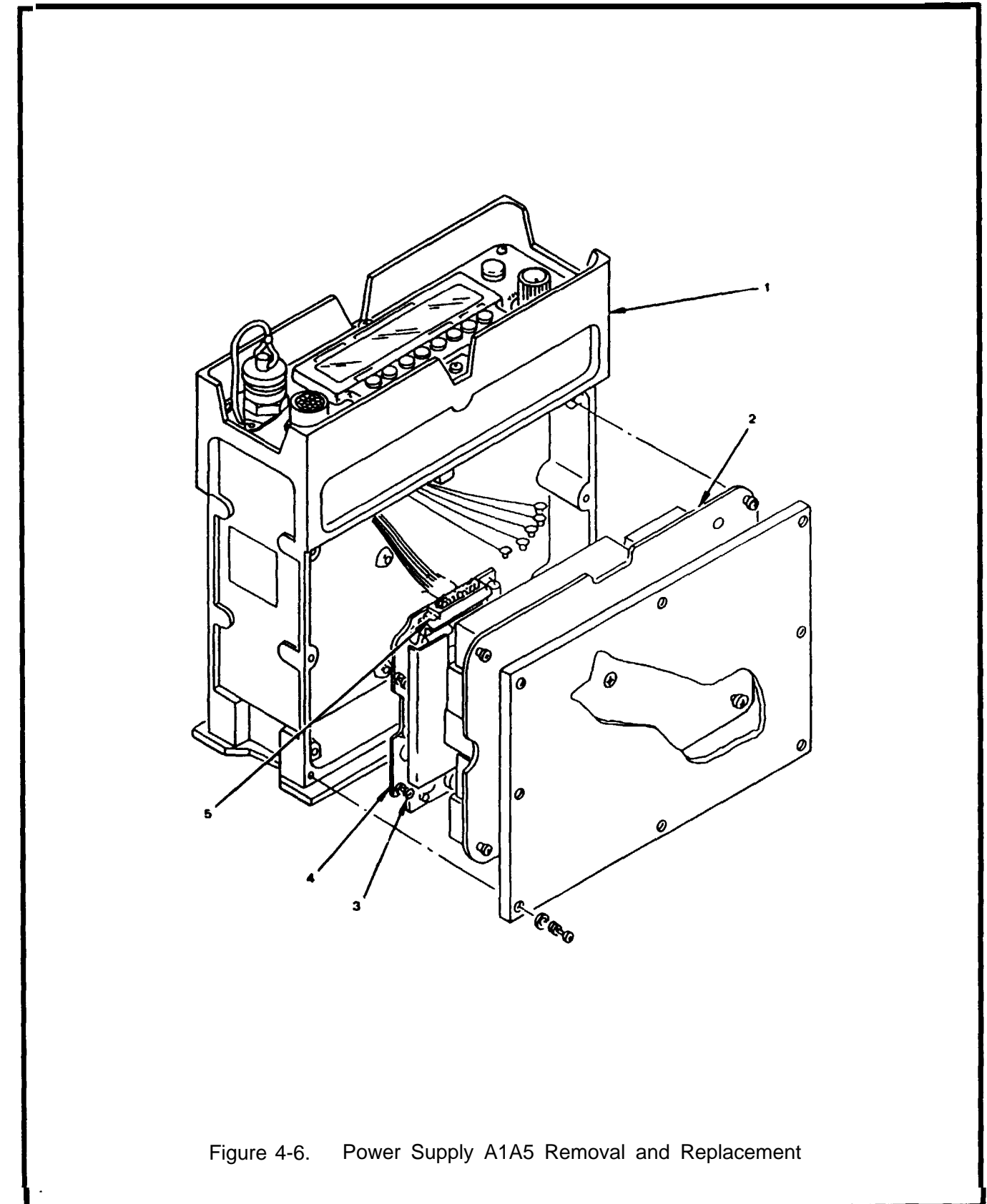

Figure 4-6. Power Supply A1A5 Removal and Replacement

**CABLE W2 REMOVAL AND REPLACEMENT, fig 4-8**

**INITIAL SETUP**

Tools:	Materials/Parts:	Personnel Required:
Tool Kit, Electronic Equipment General Support Maintenance Kit	None	1

**WARNING**

De-energize equipment before removing or replacing cable W2.

**CAUTION**

Use ESD precautionary procedures when handling, removing, or replacing cable W2.

**REMOVAL**

1. Remove modulator/demodulator (5) CCA, by performing procedures per Modulator/Demodulator A1A1 Removal (page 4-9).
2. Remove synthesizer (3) CCA, by performing procedures per Synthesizer A1A3 Removal (page 4-12).

**CAUTION**

Ensure RT does not fall over.

3. Place RT so EFP (1) is facing ceiling.

To prevent damage to cable or nearby components, care should be taken when removing cable.

4. Grasp one end of cable W2 (4) and gently pull cable out of housing (2).

**REPLACEMENT**

**CAUTION**

To prevent damage to cable or nearby components, care should be taken when replacing cable.

1. Place RT so EFP (1) is facing ceiling.
2. Insert cable W2 (4) between printed wiring board and middle divider of RT housing (2).
3. Replace synthesizer (3) CCA, by performing procedures per Synthesizer A1A3 Replacement (page 4-12).
4. Replace modulator/demodulator (5) CCA, by performing procedures per Modulator/Demodulator Replacement (page 4-9).

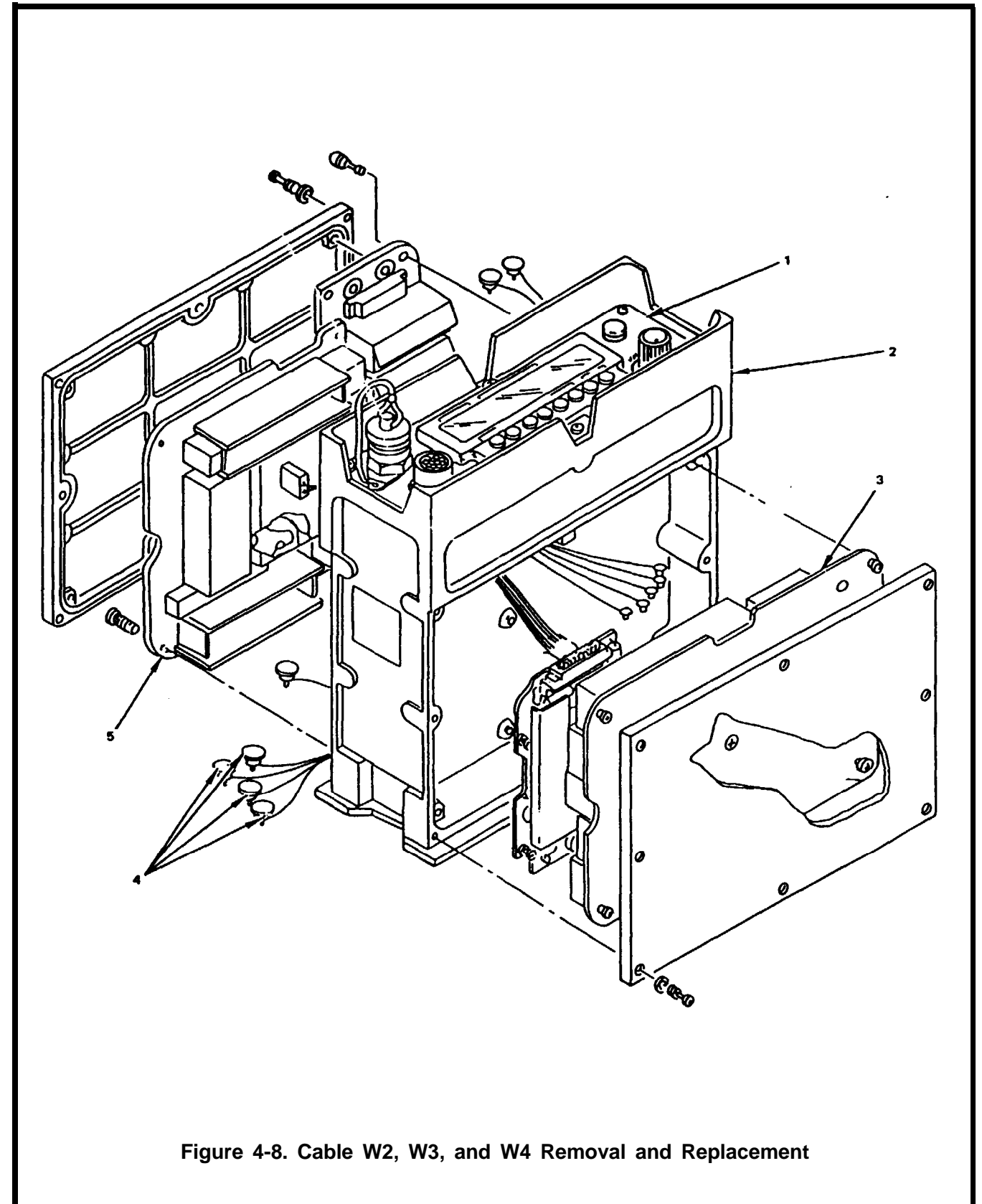

Figure 4-8. Cable W2, W3, and W4 Removal and Replacement

**CABLE W2 REMOVAL AND REPLACEMENT, fig 4-8**

**INITIAL SETUP**

Tools:	Materials/Parts:	Personnel Required:
Tool Kit, Electronic Equipment General Support Maintenance Kit	None	1

**WARNING**

De-energize equipment before removing or replacing cable W2.

**CAUTION**

Use ESD precautionary procedures when handling, removing, or replacing cable W2.

**REMOVAL**

1. Remove modulator/demodulator (5) CCA, by performing procedures per Modulator/Demodulator A1A1 Removal (page 4-9).
2. Remove synthesizer (3) CCA, by performing procedures per Synthesizer A1A3 Removal (page 4-12).

**CAUTION**

Ensure RT does not fall over.

3. Place RT so EFP (1) is facing ceiling.

To prevent damage to cable or nearby components, care should be taken when removing cable.

4. Grasp one end of cable W2 (4) and gently pull cable out of housing (2).

**REPLACEMENT**

**CAUTION**

To prevent damage to cable or nearby components, care should be taken when replacing cable.

1. Place RT so EFP (1) is facing ceiling.
2. Insert cable W2 (4) between printed wiring board and middle divider of RT housing (2).
3. Replace synthesizer (3) CCA, by performing procedures per Synthesizer A1A3 Replacement (page 4-12).
4. Replace modulator/demodulator (5) CCA, by performing procedures per Modulator/Demodulator Replacement (page 4-9).

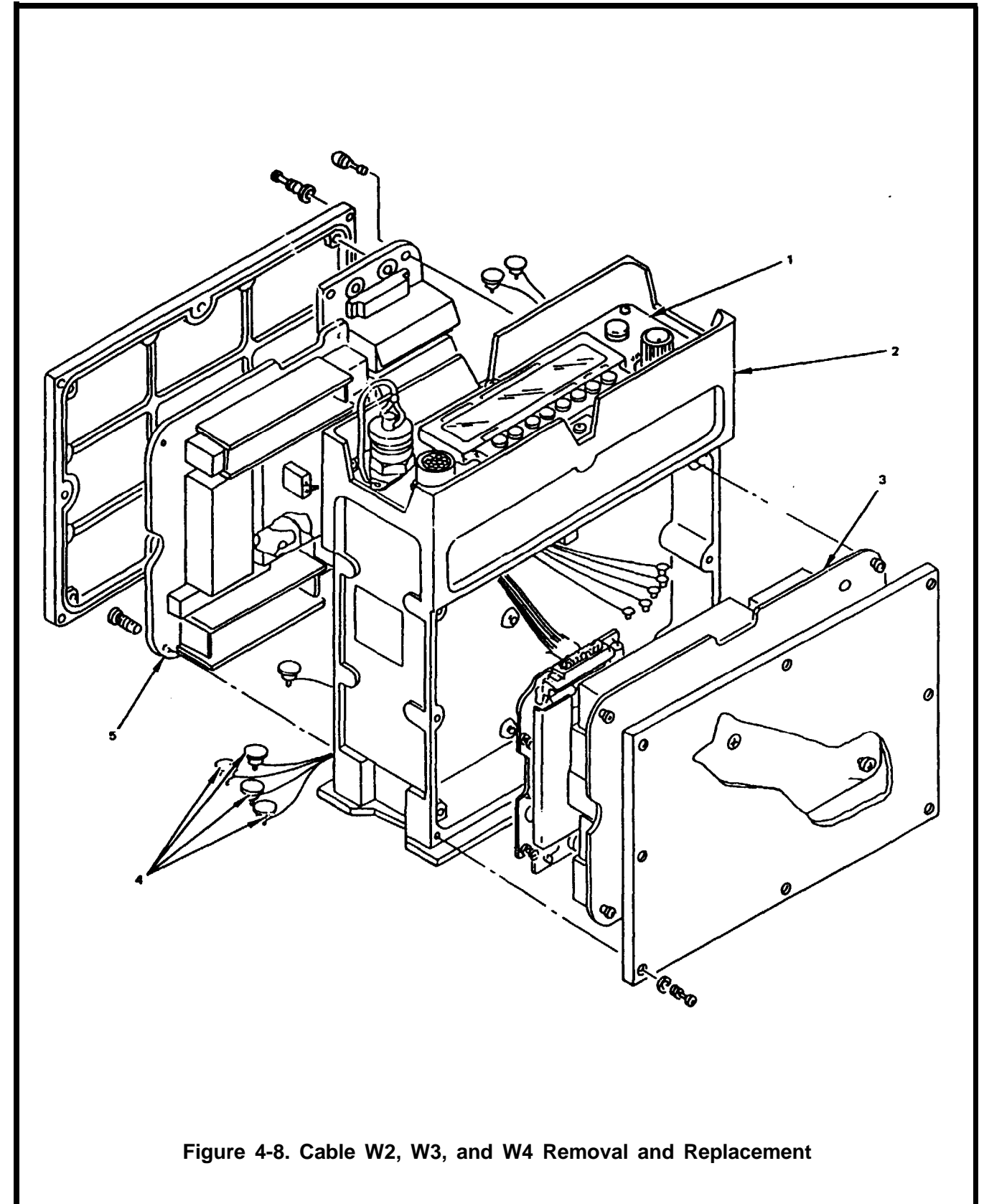

Figure 4-8. Cable W2, W3, and W4 Removal and Replacement

**CABLE W3 REMOVAL AND REPLACEMENT, fig 4-8**

<b>INITIAL SETUP</b>		
Tools:	Materials/Parts:	Personnel Required
Tool Kit, Electronic Equipment General Support Maintenance Kit	None	1
<b>WARNING</b>		
De-energize equipment before removing or replacing cable W3.		
<b>CAUTION</b>		
Use ESD precautionary procedures when handling, removing, or replacing cable W3.		
<b>REMOVAL</b>		
<ol style="list-style-type: none"> <li>1. Remove modulator/demodulator (5) CCA, by performing procedures per Modulator/Demodulator A1A1 Removal (page 4-9).</li> <li>2. Remove synthesizer (3) CCA, by performing procedures per Synthesizer A1A3 Removal (page 4-12).</li> </ol>		
<b>CAUTION</b>		
Ensure RT does not fall over.		
<ol style="list-style-type: none"> <li>3. Place RT so EFP (1) is facing ceiling.</li> </ol>		
<b>CAUTION</b>		
To prevent damage to cable or nearby components, care should be taken when removing cable.		
<ol style="list-style-type: none"> <li>4. Grasp one end of cable W3 (4) and gently pull cable out of housing (2).</li> </ol>		
<b>REPLACEMENT</b>		
<b>CAUTION</b>		
To prevent damage to cable or nearby components, care should be taken when replacing cable.		
<ol style="list-style-type: none"> <li>1. Place RT so EFP (1) is facing ceiling.</li> <li>2. Insert cable W3 (4) between printed wiring board and middle divider of RT housing (2).</li> <li>3. Replace synthesizer (3) CCA, by performing procedures per Synthesizer A1A3 Replacement (page 4-12).</li> <li>4. Replace modulator/demodulator (5) CCA, by performing procedures per Modulator/Demodulator A1A1 Replacement (page 4-9).</li> </ol>		

**CABLE W4 REMOVAL AND REPLACEMENT, fig 4-8**

<b>INITIAL SETUP</b>		
Tools:	Materials/Parts:	Personnel Required:
Tool Kit, Electronic Equipment General Support Maintenance Kit	None	1
<b>WARNING</b>		
De-energize equipment before removing or replacing cable W4.		
<b>CAUTION</b>		
Use ESD precautionary procedures when handling, removing or replacing cable W4.		
<ol style="list-style-type: none"> <li>1. Remove modulator/demodulator (5) CCA, by performing procedures per Modulator/Demodulator A1A1 Removal (page 4-9).</li> <li>2. Remove synthesizer (3) CCA, by performing procedures per Synthesizer A1A3 Removal (page 4-12).</li> <li>3. Place RT so EFP (1) is facing ceiling.</li> </ol>		
<b>CAUTION</b>		
To prevent damage to cable or nearby components, care should be taken when removing cable.		
<ol style="list-style-type: none"> <li>4. Grasp one end of cable W4 (4) and gently pull cable out of housing (2).</li> </ol>		
<b>REPLACEMENT</b>		
<b>CAUTION</b>		
To prevent damage to cable or nearby components, care should be taken when replacing cable.		
<ol style="list-style-type: none"> <li>1. Place RT so EFP (1) is facing ceiling.</li> <li>2. Insert cable W4 (4) between printed wiring board and middle divider of RT housing (2).</li> <li>3. Replace synthesizer (3) CCA, by performing procedures per Synthesizer A1A3 Replacement (page 4-12).</li> <li>4. Replace modulator/demodulator (5) CCA, by performing procedures per Modulator/Demodulator A1A1 Replacement (page 4-9).</li> </ol>		

**CABLE W5 REMOVAL AND REPLACEMENT, fig 4-9**

**INITIAL SETUP**

Tools:	Materials/Parts:	Personnel Required
Tool Kit, Electronic Equipment General Support Maintenance Kit	None	1

**WARNING**

De-energize equipment before removing or replacing cable W5.

**CAUTION**

Use ESD precautionary procedures when handling, removing, or replacing cable W5.

**REMOVAL**

1. Remove synthesizer (8) CCA, by performing procedures per Synthesizer A1A3 Removal (page 4-12).
2. Loosen 6 captive screws (2) on EFP (3).

**CAUTION**

To prevent damage to cables and cable W6, care should be taken to prevent EFP from falling out when captive screws are loosened.

3. Pull EFP (3) out by grasping AUDIO connector plug and VOLUME OFF/MAX switch ensuring ribbon cable W1 (7) and cable W6 (6) are not damaged.
4. Disconnect rf cable W5 (5) from control interface unit (1).

**CAUTION**

To prevent damage to cable or nearby components, care should be taken when removing cable.

5. Grasp one end of rf cable W5 (5) and pull cable out of housing (4).

**REPLACEMENT**

**CAUTION**

To prevent damage to cable or nearby components, care should be taken when replacing cable.

1. Place RT so EFP (3) is facing ceiling.
2. Insert rf cable W5 (5) between control interface unit (1) and middle divider of RT housing (4).
3. Connect rf cable W5 (5) to copntrol interface unit (1).
4. Slide EFP (3) into housing and fasten 6 captive screws (2).
5. Replace synthesizer (8) CCA, by performing procedures per Synthesizer A1A3 Replacement (page 4-12).

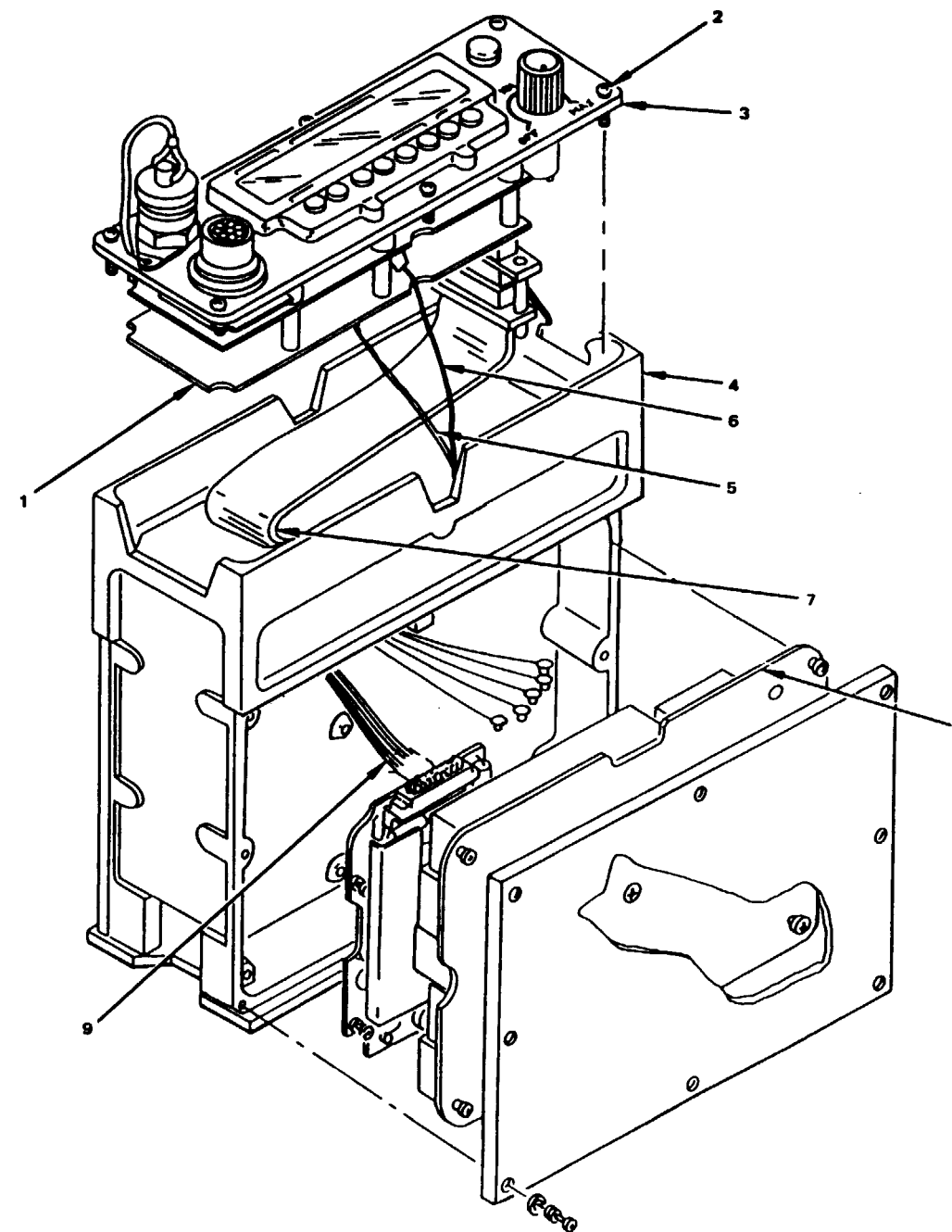

Figure 4-9. Cable W5 and W6 Removal and Replacement

**CABLE W6 REMOVAL AND REPLACEMENT, fig 4-9****INITIAL SETUP****Tools:**

Tool Kit, Electronic Equipment  
General Support Maintenance Kit

**Materials/Parts:**

None

**Personnel Required:**

1

**WARNING**

De-energize equipment before removing or replacing cable W6.

**CAUTION**

Use ESD precautionary procedures when handling, removing, or replacing cable W6.

**REMOVAL**

1. Remove modulator/demodulator CCA, by performing procedures per Modulator/Demodulator A1A1 Removal (*page 4-9*).
2. Place RT so EFP (3) is facing ceiling.
3. Loosen 6 captive screws (2) on EFP (3).

**CAUTION**

To prevent damage to cables and cable W6, care should be taken to prevent EFP from falling out when captive screws are loosened.

4. Pull EFP (3) out by grasping AUDIO connector plug and VOLUME OFF/MAX switch.
5. Disconnect cable W6 (6) from control interface unit (1).
6. Grasp one end of cable W6 and pull cable W6 out of housing (4).

**REPLACEMENT****CAUTION**

To prevent damage to cable or nearby components, care should be taken when replacing cable.

1. Place RT so EFP (3) is facing ceiling.
2. Insert cable W6 (6) between control interface unit (1) and middle divider of RT housing (4).
3. Connect cable W6 to control interface unit (1).
4. Slide EFP (3) into housing and fasten 6 captive screws (2).
5. Replace modulator/demodulator CCA, by performing procedures per Modulator/Demodulator A1A1 Replacement (*page 4-9*).

**ELECTRONIC FRONT PANEL (EFP) A1A4 DETAILED REMOVAL AND REPLACEMENT**  
 (1 of 2), fig 4-10

**INITIAL SETUP**

Tools:	Materials/Parts:	Personnel Required
Tool Kit, Electronic Equipment General Support Maintenance Kit	None	1

**WARNING**

De-energize equipment before removing or replacing the EFP.

**CAUTION**

Use ESD precautionary procedures when handling, removing, or replacing the EFP.

**REMOVAL**

1. Remove EFP assembly (22), by performing procedures per Electronic Front Panel (EFP) A1A4 Removal (page 4-13).
2. Remove rubber boot (1) on LIGHT pushbutton switch (6).
3. Loosen set screw on VOLUME OFF/MAX switch, S2, knob (2) and remove knob.
4. Remove nut assembly under S2 knob (2). Nut assembly consists of nut (3) and flat washer (4).
5. Remove nuts (20, 21) on CONT connector (17) and AUDIO connector plug (18).
6. Remove 6 screws (15) on Control Panel interface Analog Subassembly, A1A4A2 (11).
7. Gently lift up and flip over A1A4A2 (11), as ribbon cable allows, so A1A4A2 (11) and Control Panel interface Digital Subassembly, A1A4A1 (8), lay flat, side-by-side.
8. Loosen 6 studs (10) with attaching flat washers (9).
9. Place EFP assembly (22) on fiat surface. Take S1 (6) and S2 (7) (with O-ring (5)) out of their openings. Lift out all circuit boards and attached assemblies (8, 11, 16, 17, 18), as ribbon cables (16) permit.
10. Connections made at ribbon cables (16) must be unsoldered to remove either the AUDIO connector plug (18) or CONT connector plug (17).

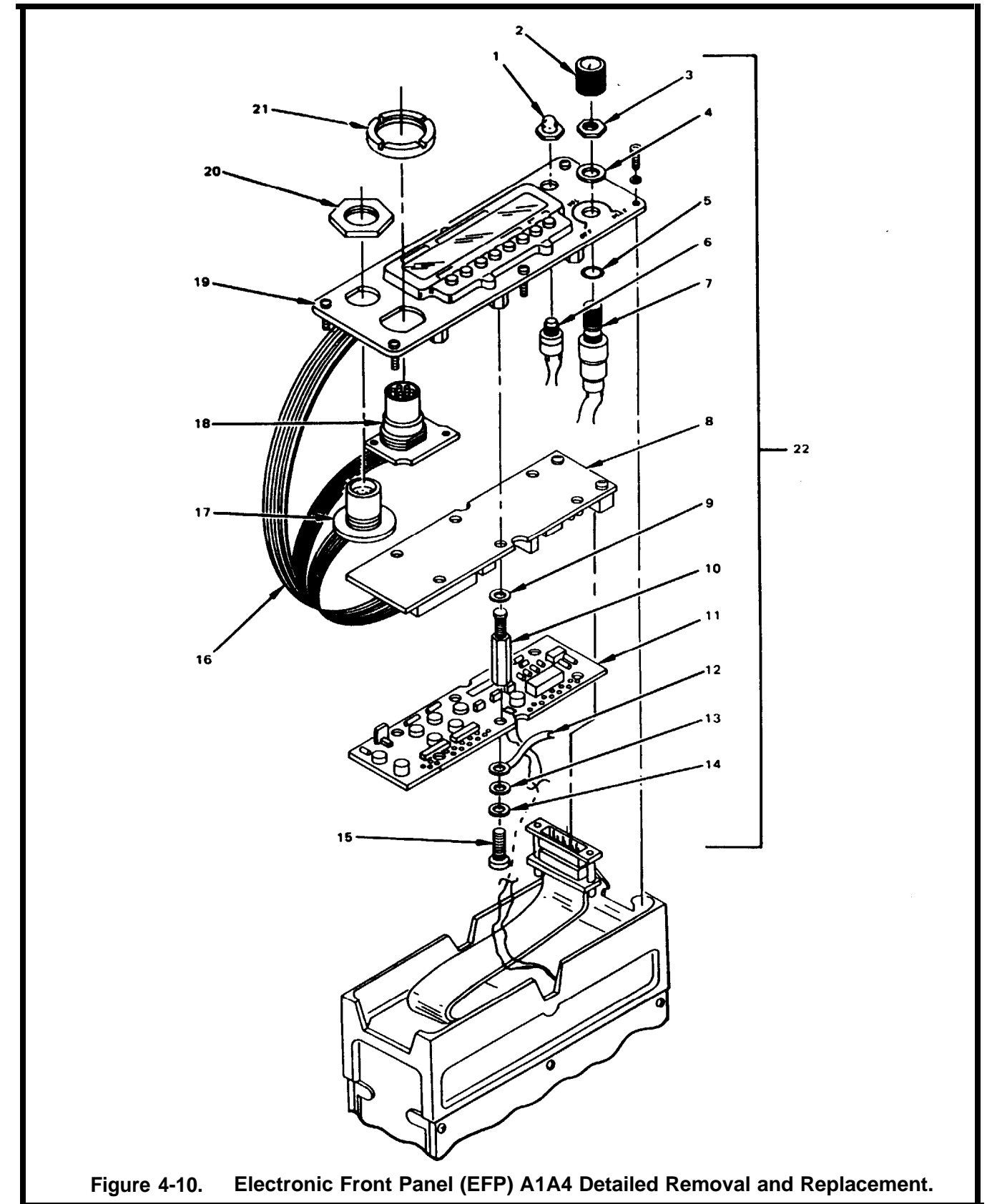

Figure 4-10. Electronic Front Panel (EFP) A1A4 Detailed Removal and Replacement.



**ELECTRONIC FRONT PANEL (EFP) A1A4 DETAILED REMOVAL AND REPLACEMENT**  
**(2 of 2), fig 4-10****REPLACEMENT**

1. All connections between **AUDIO** connector plug (18) and **CONT** connector plug (17) and ribbon cables (16) must be soldered.
2. Place **AUDIO** connector plug (18) and **CONT** connector plug (17) in their respective openings on Front Panel Assembly (19) and tighten nuts (20, 21).
3. Replace O-ring (5) on S2 (7), and place S2 and S1 (6) in their respective openings on Front Panel Assembly (19).
4. Replace rubber boot (1) on S1 (6), and flat washer (4), nut (3), and knob (2) on S2 (7).
5. Tighten 6 studs (10) with attaching flat washers (9) on A1A4A1 (8).
6. Place A1A4A2 (11) on top of A1A4A1 (8) and replace 6 screws (15) with lock washers (14), flat washers (13), and ground lugs (12).
7. Replace EFP assembly (22), by performing procedures per Electronic Front Panel (EFP) A1A4 Replacement (page 4-13).

BLANK  
INTENTIONALLY

## CHAPTER 5 AMPLIFIER/COUPLER MAINTENANCE

### Section I. INTRODUCTION AND TOOLS

	Page
Introduction .....	5-1
Amplifier/Coupler Special Tools .....	5-1
Amplifier/Coupler Test Equipment .....	5-1

#### INTRODUCTION

This chapter provides the information necessary to maintain Radio Frequency Amplifier AM-6874/PRC-104 (amplifier/coupler). Information required for the repair of the amplifier/coupler housing and covers is contained in RS-07748A-50/4. The performance test and troubleshooting flowchart checks out the amplifier/coupler and aids the maintenance technician in isolating a fault to a module or a component of the unit. Complete disassembly and reassembly procedures are provided for the amplifier/coupler (A2). Chapter 7 contains all maintenance data for the two amplifier/coupler modules:

1. Power Amplifier A2A1
2. Antenna Tuner A2A2

#### AMPLIFIER/COUPLER SPECIAL TOOLS

The special tools, materials, and fabricated test cables and fixtures required for maintenance of the amplifier/coupler are listed in the table below. Tools and materials in the tables on *pages 3-4 and 3-5* should also be considered when unit repair is required. For Army personnel, refer to Repair Parts and Special Tools List TM 11-5820-1 046-40P.

Description	Part Number
Audio Input/Keying Adapter	...
Whip Adapter	...
Tool Kit, Electronic Equipment	TK-105/G
Bench Repair Center	Pace PRC-350C
Maintenance Kit, Printed Circuit	MK-9841A
O-Ring Lubricant, Barium Base	755002A7551

#### AMPLIFIER/COUPLER TEST EQUIPMENT

The following lists the equipment required to test the amplifier/coupler. Refer to page 1-6 for equipment characteristics.

#### NOTES

1. Equivalent test equipment may be used.
2. Use only test equipment that is properly calibrated. Failure to do so may provide erroneous or misleading performance or fault indications.
3. If adequate wattmeter is not available, substitute VTVM terminated with dummy load,  $P = E^2/R$ , where  $R = 50$  ohms.

Name	Quantity
Radio Set, Test Bed	1
VTVM	1
Signal Generator, RF	1
Attenuator, Step 10-db steps, 0.5w, 50 ohm	1
Wattmeter, RF	
— Power Meter	1
— Thermocouple Power Sensor	1
Power Supply, DC	1
Attenuator, Coaxial 20db, 30w min., 50 ohm	1

BLANK  
INTENTIONALLY

**Section II. AMPLIFIER/COUPLER TROUBLESHOOTING**

	<b>Page</b>
Introduction .....	5-3
Amplifier/Coupler Power Distribution .....	5-4
Amplifier/Coupler RF Cabling .....	5-4
Test Setup .....	5-5
Amplifier/Coupler Troubleshooting Procedure .....	5-6

**INTRODUCTION**

The performance test and troubleshooting procedures are combined into a single flowchart format (chapter 3). This allows the maintenance technician to check the amplifier/coupler (A2) for normal indications, and to branch off for fault isolation if an abnormal indication exists. The troubleshooting flowchart is an aid for isolating to a probable fault and should be used in conjunction with the functional block diagrams. Once a fault has been located and corrected, the performance test is repeated. Do not skip blocks in the performance test, because succeeding blocks may be based upon certain faults being eliminated.

**AMPLIFIER/COUPLER POWER DISTRIBUTION, fig 5-1**

The power distribution diagram for the amplifier/coupler is shown below.

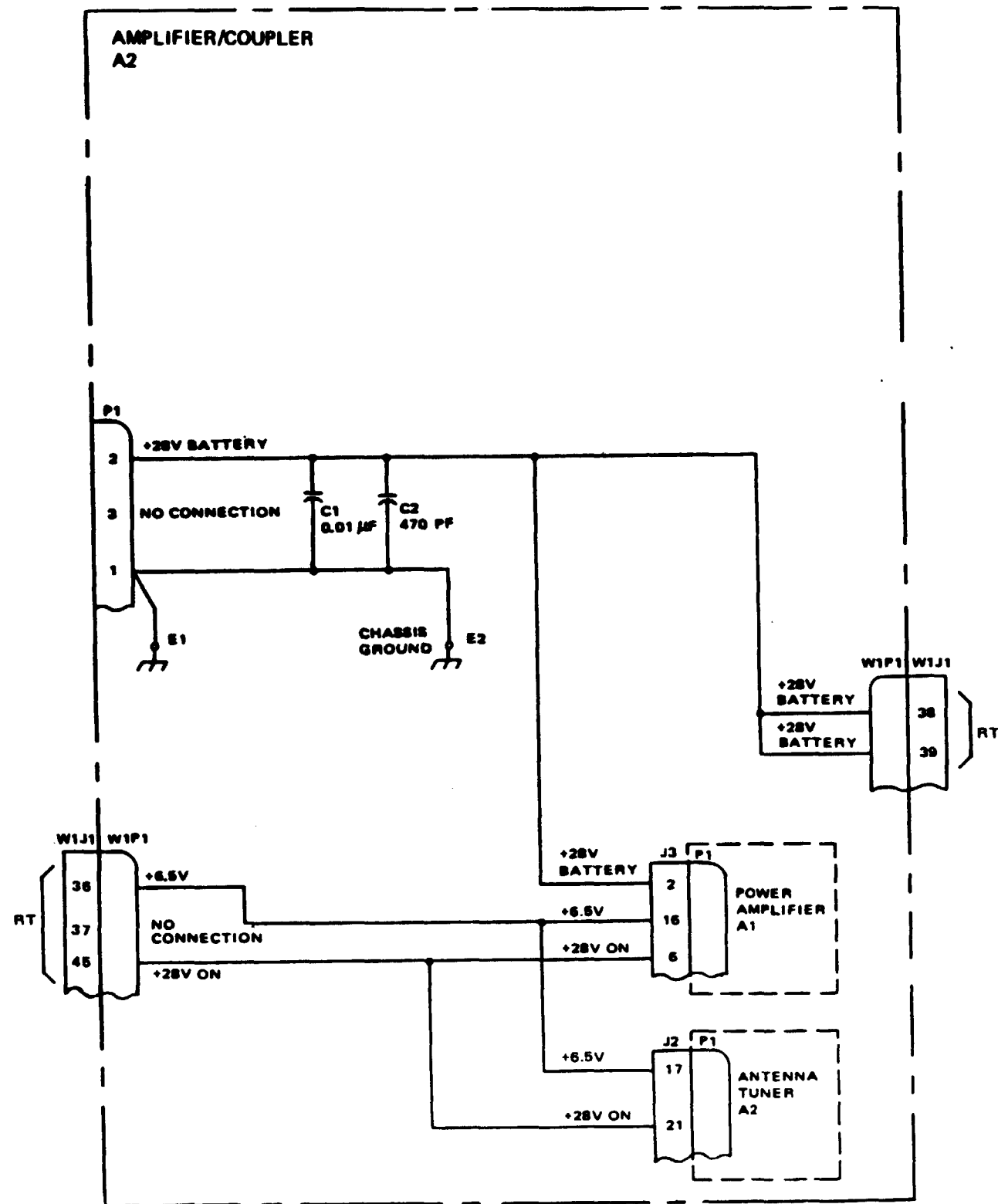

Figure 5-1. Amplifier/Coupler Power Distribution

**AMPLIFIER/COUPLER RF CABLING, fig 5-2**

The rf cabling diagram for the amplifier/coupler is shown below.

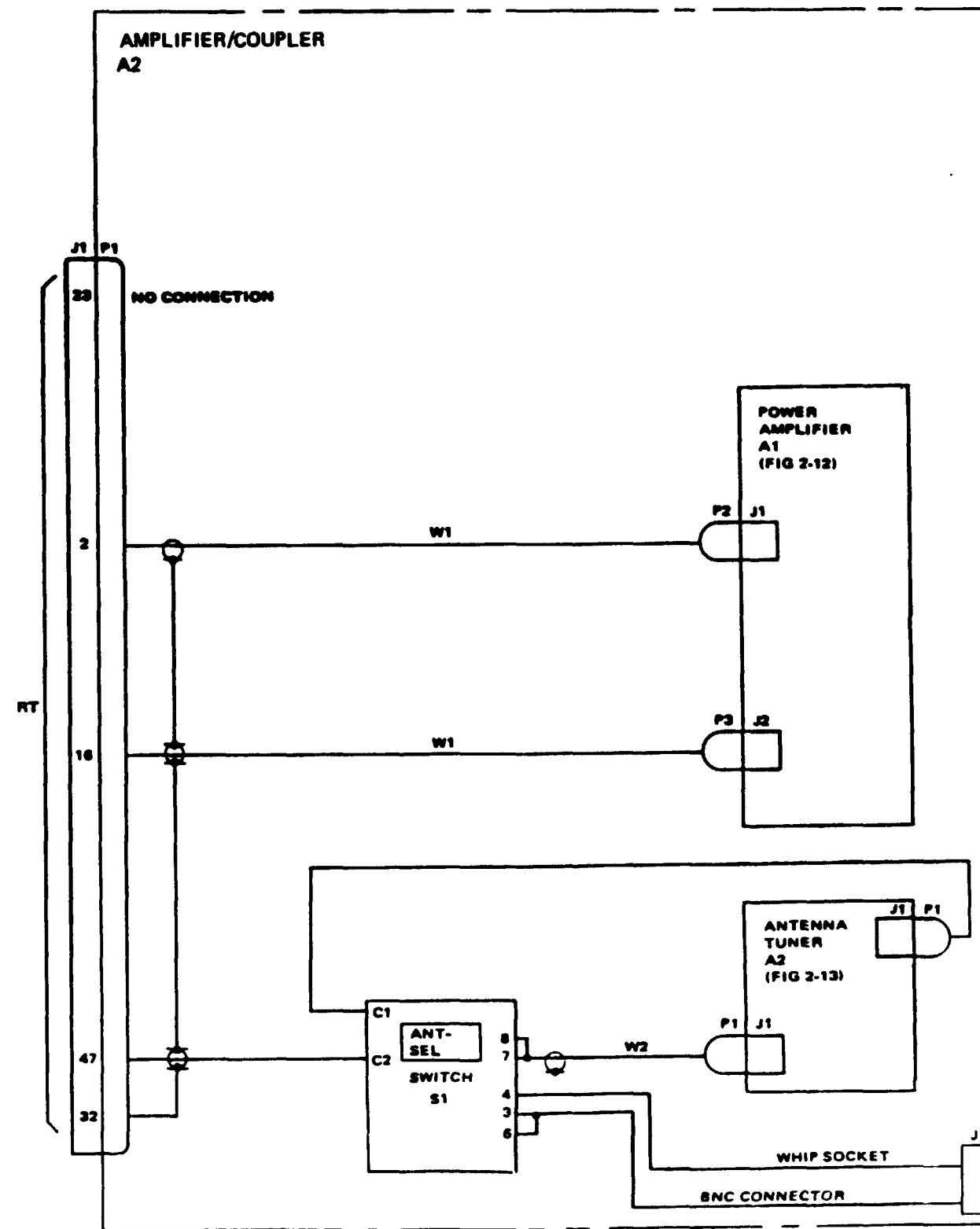

Figure 5-2. Amplifier/Coupler RF Cabling

**TEST SETUP, fig 5-3**

The troubleshooting procedure setup for the amplifier/coupler is shown in the diagram below.

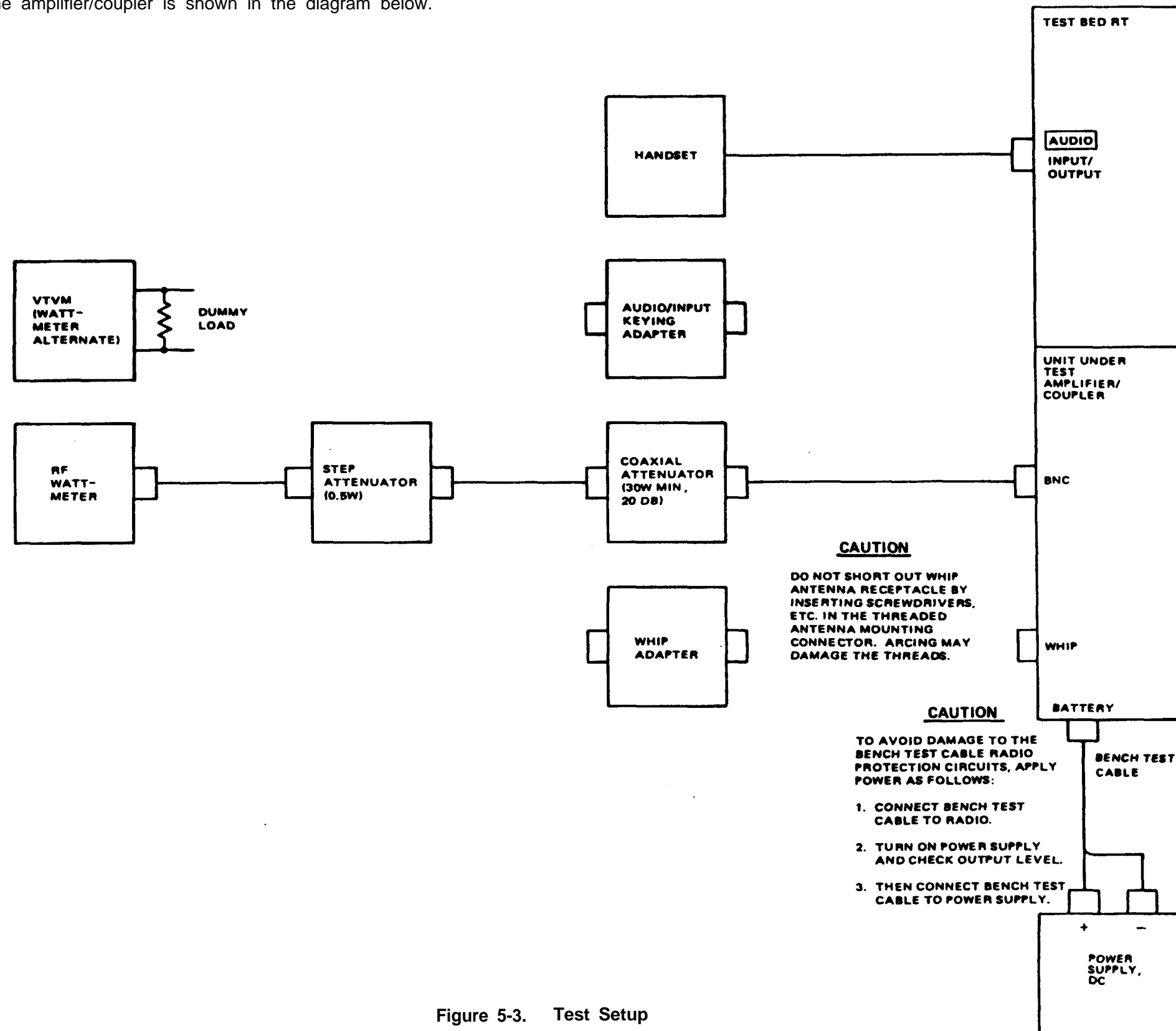
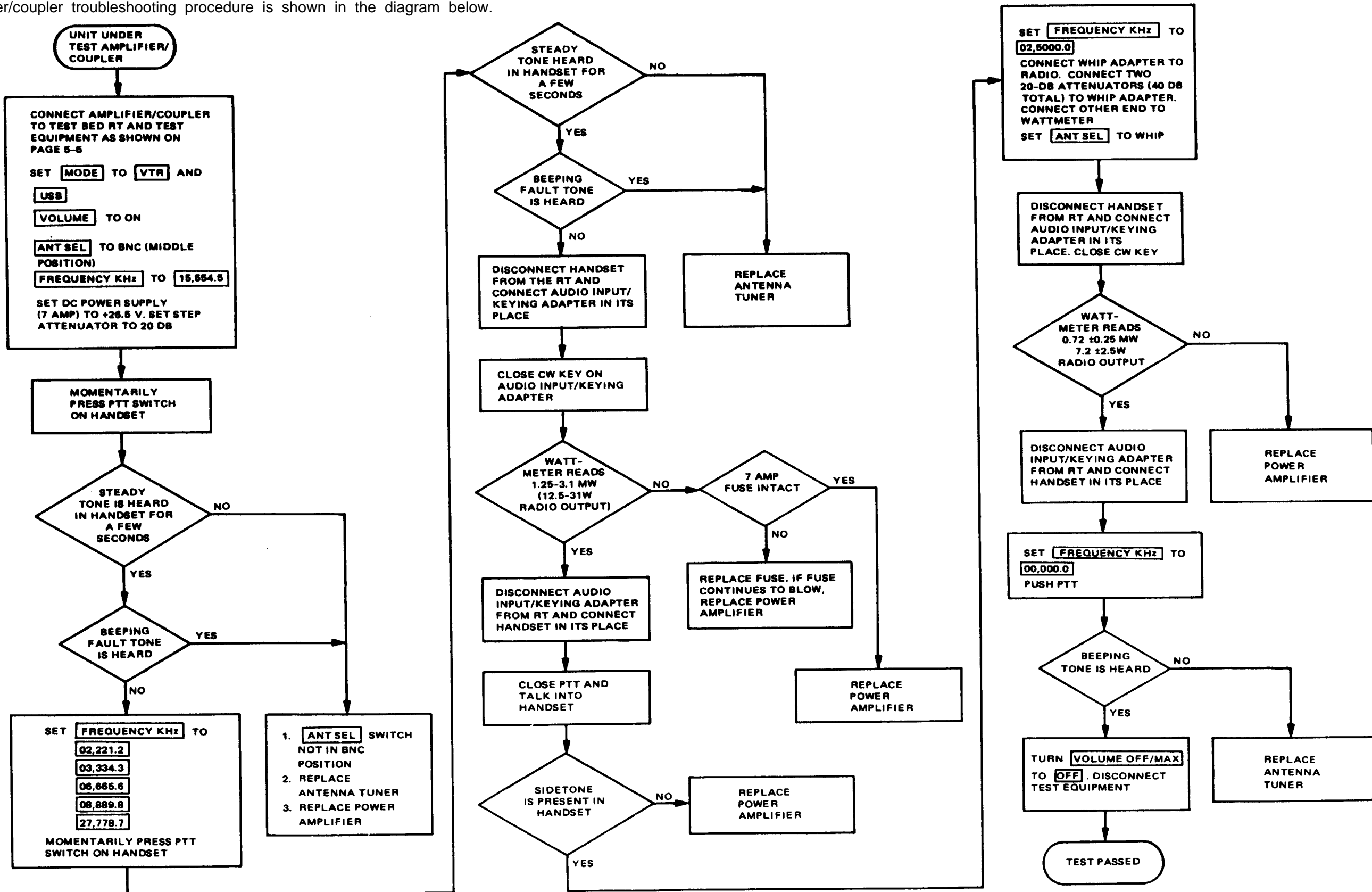

Figure 5-3. Test Setup

**AMPLIFIER/COUPLER TROUBLESHOOTING PROCEDURE**

The amplifier/coupler troubleshooting procedure is shown in the diagram below.





**Section III. AMPLIFIER/COUPLER DISASSEMBLY AND REASSEMBLY**

	Page		Page
Introduction .....	5-7	Antenna Mount Removal and Replacement .....	5-12
Amplifier/Coupler Disassembly and Reassembly .....	5-7	BNC Connector A2J1 Removal and Replacement .....	5-12
Power Amplifier A2A1 Removal and Replacement .....	5-8	Antenna Select Switch A2S1 Removal and Replacement .....	5-13
Antenna Tuner A2A2 Removal and Replacement .....	5-9	Ground A2E1 Removal and Replacement .....	5-14
Ribbon Cable A2W1 Removal and Replacement .....	5-10	Latch Removal and Replacement .....	5-15

**INTRODUCTION**

Once a fault has been isolated, the disassembly and reassembly procedures in this section should be used to remove the faulty amplifier/coupler component. Component location diagrams are provided in this section for easy reference. Refer to the tables in section I of this chapter for necessary tools and test equipment.

**AMPLIFIER/COUPLER DISASSEMBLY AND REASSEMBLY**

Procedures for disassembly and reassembly of the amplifier/coupler (A2) consist of removing and replacing the power amplifier A2A1, antenna tuner A2A2, ribbon cable A2W1, BNC connector A2J1, and antenna select (ANT SEL) switch A2S1 ,

**POWER AMPLIFIER A2A1 REMOVAL AND REPLACEMENT, fig 5-4**

**INITIAL SETUP**

**Tools:**

Tool Kit, Electronic Equipment  
O-Ring Lubricant

**Materials/Parts:**

None

**Personnel Required:**

1

**WARNING**

De-energize equipment before removing or replacing the power amplifier.

**CAUTION**

Use ESD precautionary procedures when handling, removing, or replacing the power amplifier.

**REMOVAL**

1. Place amplifier/coupler so cover assembly (8) is on top and front face reads upside down.
2. Remove cover assembly (8) by loosening 8 captive screws (7).
3. Disconnect rf cables (6) from power amplifier module assembly (9).
4. Loosen 4 captive (Phillips head) screws (6) that connect power amplifier module assembly (9) to amplifier/coupler housing (4).
5. Grasp wire handle on module and pull gently upward so module is removed.

**REPLACEMENT**

1. Align power amplifier module (8) over amplifier/coupler housing (4) as shown.
2. Carefully plug module (9) into housing so multipin connector (10) and jack fit properly.
3. Tighten 4 captive screws (6) on module (9).
4. Reconnect 2 rf cables (5) to module according to colorcode.
5. Lubricate O-ring in cover assembly (8). Replace cover assembly. Tighten 8 captive screws (7).

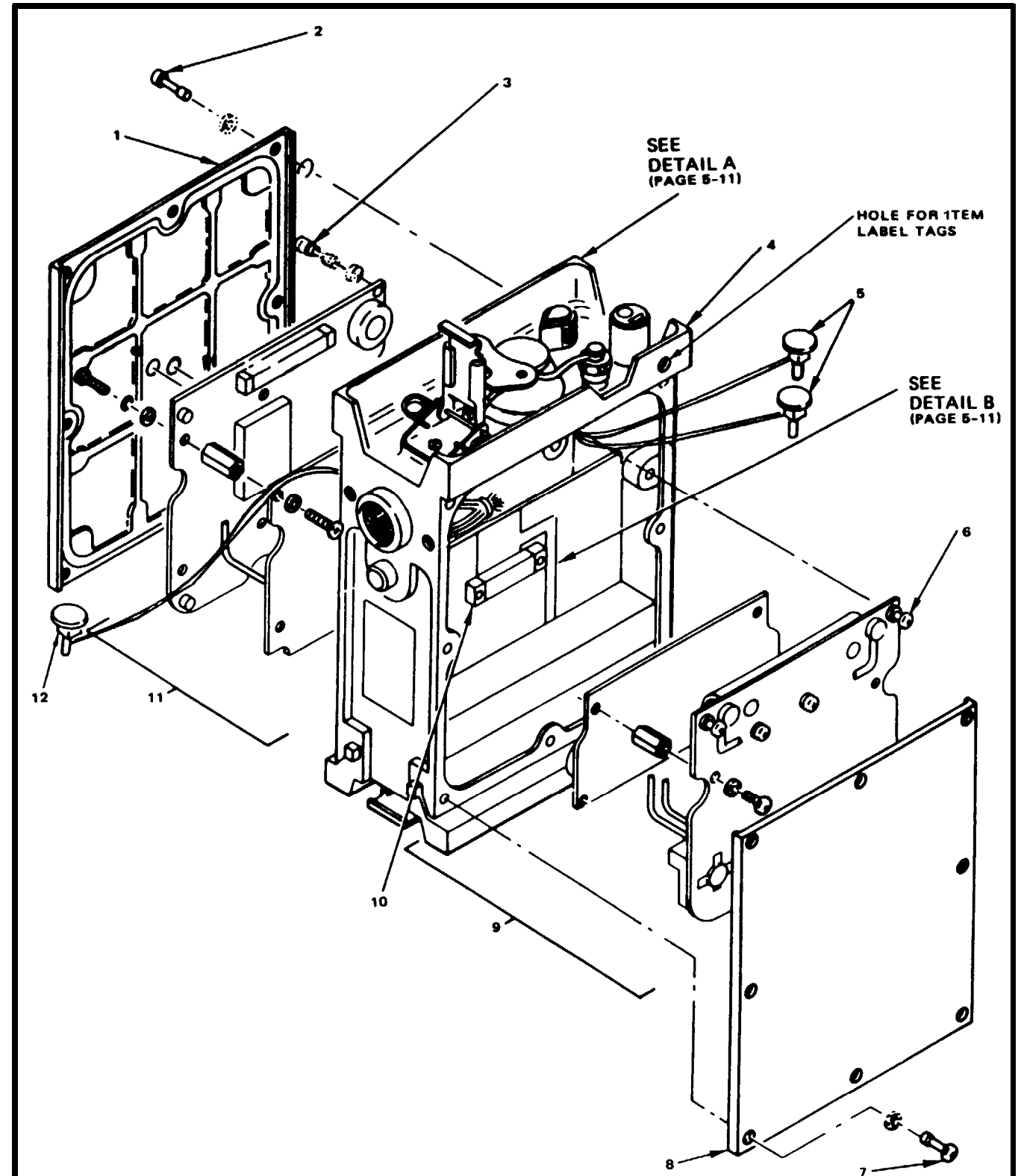

Figure 5-4. Power Amplifier A2A1 Removal and Replacement

**ANTENNA TUNER A2A2 REMOVAL AND REPLACEMENT, fig 5-5**

**INITIAL SETUP**

Tools:	Materials/parts:	Personnel Required
Tool Kit, Electronic Equipment O-Ring Lubricant	None	1

**WARNING**

De-energize equipment before removing or replacing the antenna tuner.

**CAUTION**

Use ESD precautionary procedures when handling, removing, or replacing the antenna tuner.

**REMOVAL**

1. Place amplifier/coupler so cover assembly (1) is on top.
2. Remove cover assembly (1) by loosening 8 captive screws (2).
3. Disconnect rf cable (13) from antenna tuner module assembly (11).
4. Loosen 4 captive screws (3) that connect module to amplifier/coupler housing (4).
5. Grasp module and pull gently upward so module is removed.

**REPLACEMENT**

1. Align module (11) over amplifier/coupler housing (4) as shown.
2. Carefully plug module (11) into amplifier/coupler housing (4) so multipin connector (12) and jack fit properly.
3. Tighten 4 captive screws (3) on module.
4. Reconnect rf cable (13) according to colorcode.
5. Lubricate O-ring in cover assembly (1). Replace cover assembly. Tighten 8 captive screws (2).

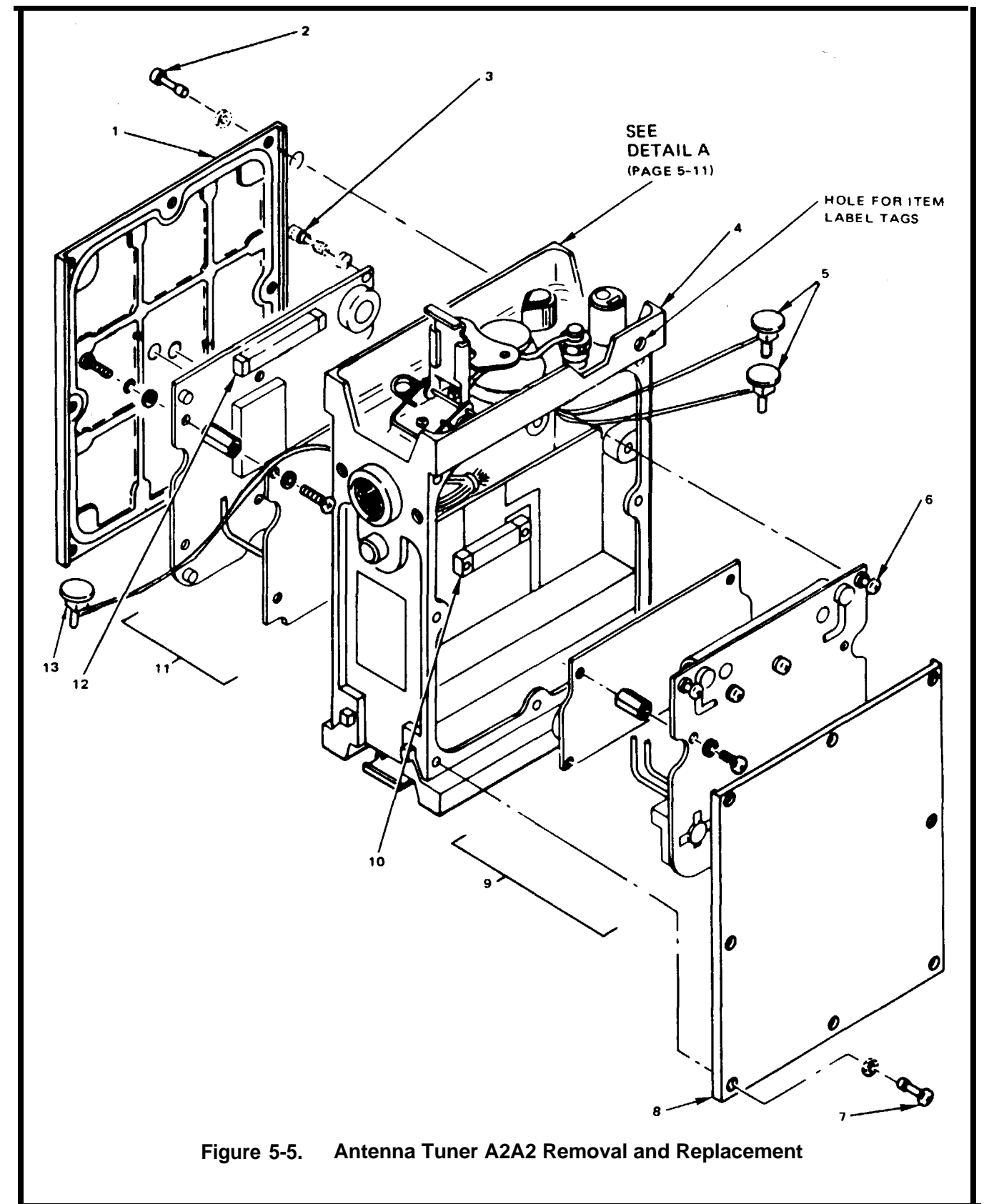

Figure 5-5. Antenna Tuner A2A2 Removal and Replacement

**RIBBON CABLE A2W1 REMOVAL AND REPLACEMENT (1 of 2), fig 5-6**

**INITIAL SETUP**

Tools:	Materials/Parts:	Personnel Required
Tool Kit, Electronic Equipment	None	1

**WARNING**

De-energize equipment before removing or replacing ribbon cable A2W1.

**CAUTION**

Use ESD precautionary procedures when handling, removing, or replacing ribbon cable A2W1.

**REMOVAL**

**NOTE**

Remove power amplifier and antenna tuner before attempting removal of ribbon cable A2W1.

1. Locate connector receptacle (19) on side of amplifier/coupler housing (7).
2. Remove mounting screws of multipin connector (18) which are located on opposite side of amplifier/coupler unit just below multipin connector (26).
3. Remove screw and nut that mount terminal (25) to amplifier/coupler housing (7) adjacent to multipin connector (19).
4. Remove mounting screw (17) for multipin connector (26), which are located on opposite side of amplifier/coupler unit, just above multipin connector (18).
5. Place amplifier/coupler so battery connector (13) faces upward and remove 2 mounting screws (14) with associated washers.
6. Remove screw and nut that mount terminal (25) to amplifier/coupler housing (7) at base of multipin connector (20) adjacent to capacitors (15).

**CAUTION**

Use extreme care when removing ribbon cables. Creasing or severe bending will damage ribbon cables internally.

7. Grasp ribbon cable support (23) and ribbon cable assembly (24) and slowly pull backward until notched area of circuit card is separated from raised portion of amplifier/coupler housing. Lift circuit card and ribbon cable assembly up and forward until connector receptacle (19) is separated from amplifier/coupler housing (7).
8. Place amplifier/coupler housing (7) so multipin connector (18) faces upward. Slowly lift up and carefully pull back ribbon cable support (23) and ribbon cable assembly (24).
9. Grasp bottom of battery connector (13) and slowly pull ribbon cable assembly outward separating battery connector from amplifier/coupler housing (7).
10. Unsolder ribbon cable assembly from battery connector (13).
11. Grasp ribbon cable support (23) and ribbon cable assembly (24) and remove from amplifier/coupler housing (7).

**CAUTION**

Use extreme care when replacing ribbon cables. Creasing or severe bending will damage ribbon cables internally.

1. Place ribbon cable assembly (24) and ribbon cable support (23) in amplifier/coupler housing (7) so bottom of ribbon cable extends through connector opening, located at bottom of amplifier/coupler housing, allowing enough space to solder battery connector (13) onto ribbon cable (24).
2. Solder battery connector (13) onto ribbon cable terminal (25) to amplifier/coupler housing (7) by attaching mounting bracket with screw and nut.
3. Carefully push battery connector (13) into place. Attach connector screws (14) with associated washers and tighten.
4. Grasp ribbon cable support (23) and ribbon cable assembly (24) and straddle amplifier/coupler internal housing. At same time, work receptacle connector (19) into position.
5. Push ribbon cable support and ribbon cable assembly into position by carefully pushing circuit card toward connector opening (19) and then pushing circuit board forward, allowing notched portion of circuit board (23) to fit into notched portion of amplifier/coupler housing (7).
6. Align connectors (26,18) on their appropriate mounting studs.
7. Attach connector (26,18) using 2 screws, 2 lockwashers, and 2 flat washers. Screws and washers are attached from back side of connector. Attach terminal (27) adjacent to connector (27) using mounting plate, screw, and flat washer.
8. Attach connector (19) using 2 screws (28), packing (29), and nuts (20).

RIBBON CABLE A2W1 REMOVAL AND REPLACEMENT (2 of 2)

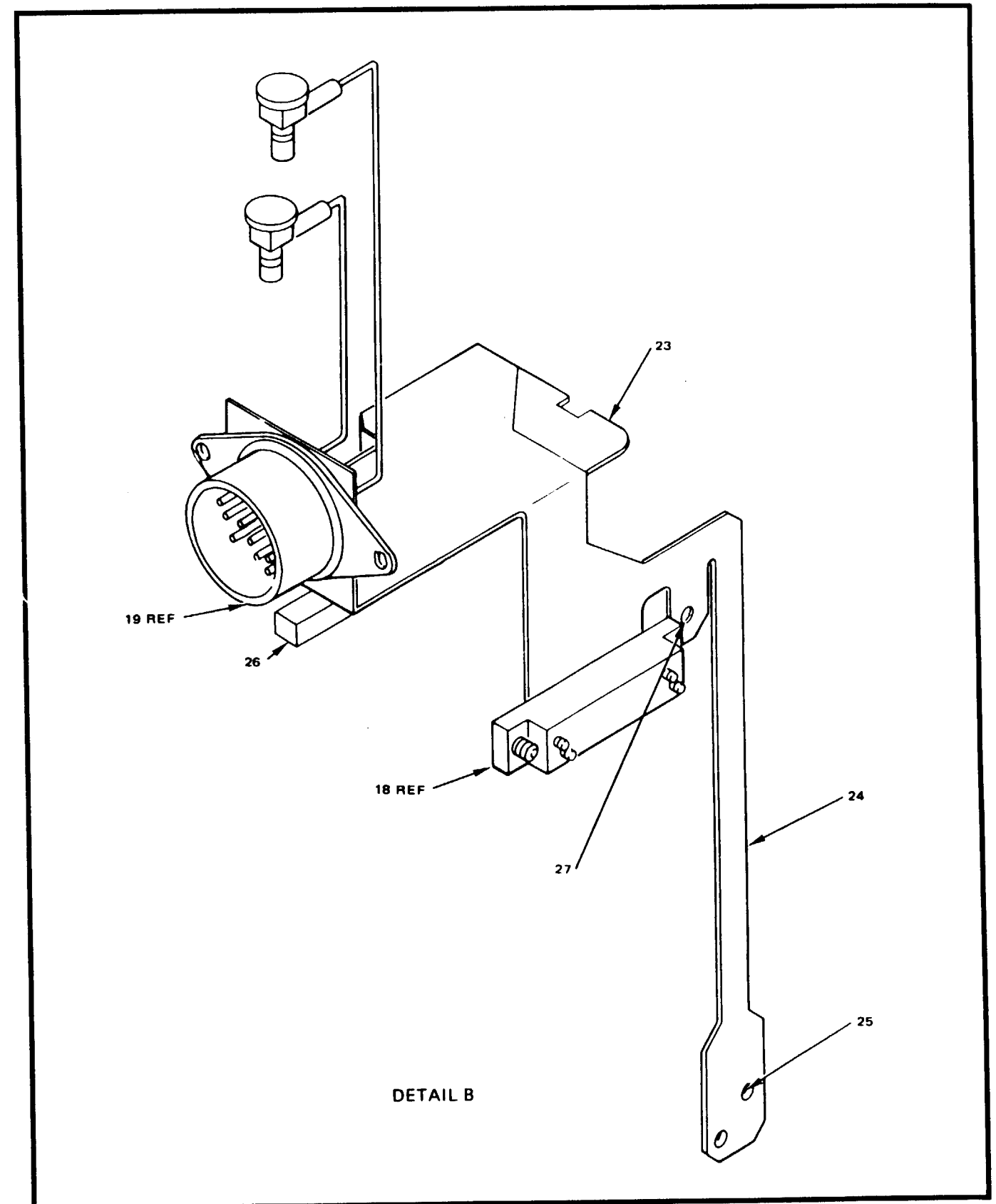
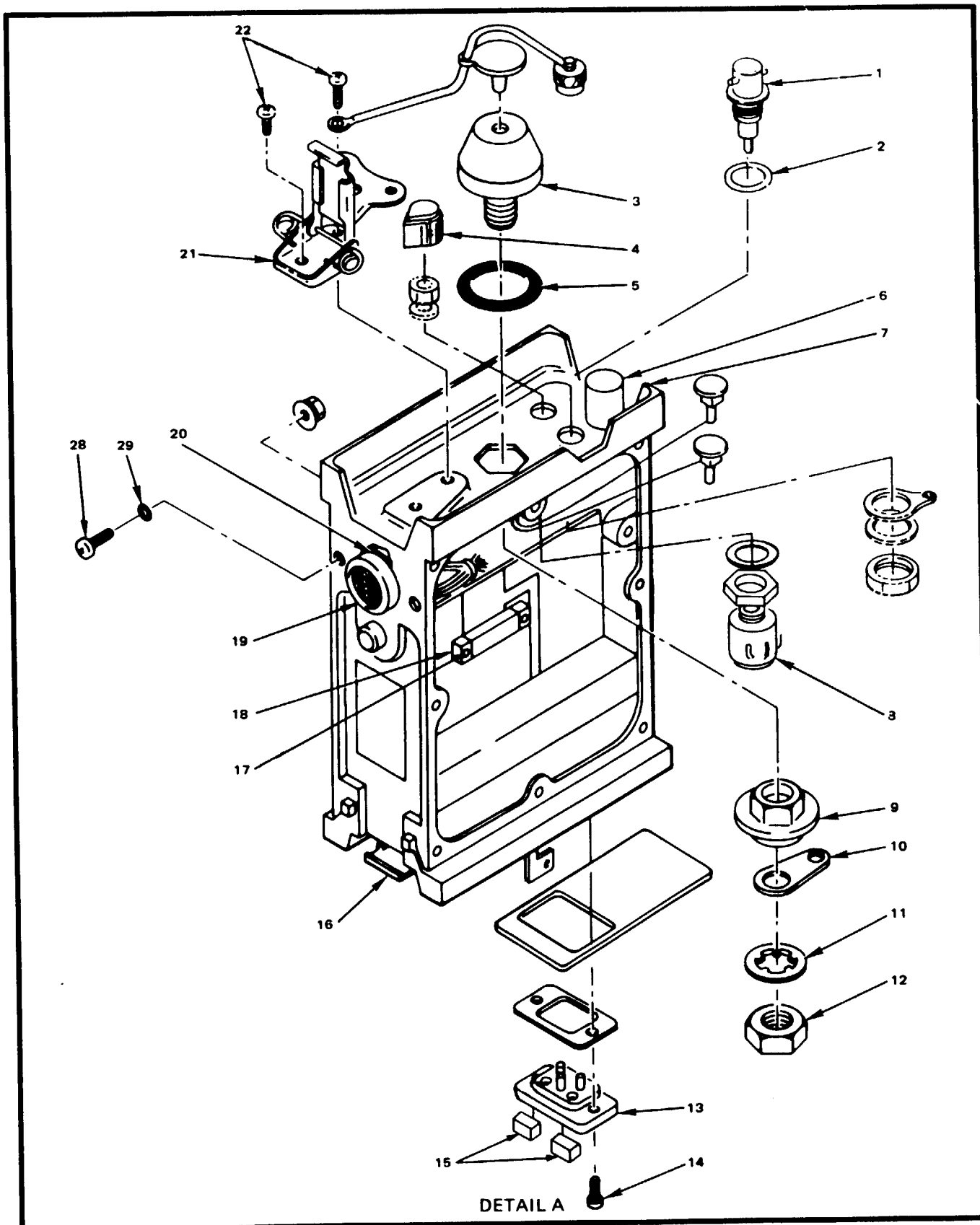

Figure 5-6. Ribbon Cable A2W1 Removal and Replacement

**ANTENNA MOUNT REMOVAL AND REPLACEMENT, fig 5-7**

**INITIAL SETUP**

Tools:	Materials/Parts:	Personnel Required:
Tool Kit, Electronic Equipment	None	1

**WARNING**

De-energize equipment before removing or replacing the antenna mount.

**CAUTION**

Use ESD precautionary procedures when handling, removing, or replacing the antenna mount.

**REMOVAL**

1. Remove ribbon cable support and ribbon cable assembly as in Ribbon Cable A2W1 Removal (page 5-10).
2. Loosen and remove nut (12) at base of whip antenna mount.
3. Remove lockwasher (11), terminal lug (10) and lower antenna mount (9).
4. Grasp upper antenna mount (1), pull upward, separating upper antenna and preform packing (3) from amplifier/coupler housing (7).

**REPLACEMENT**

1. Inspect preform packing (3). Replace if worn or cracked. Lubricate preform packing.
2. Align upper antenna mount (1) and preform packing (3) with hexagon cutout on top of amplifier/coupler housing.
3. Push upper antenna mount (1) through hex cutout.
4. Align lower antenna mount (9) with upper antenna mount (1).
5. Push lower antenna mount (9) into hex cutout.
6. Attach terminals lug (10).
7. Attach lockwasher (11).
8. Attach nut (12) and tighten.

**BNC CONNECTOR A2J1 REMOVAL AND REPLACEMENT, fig 5-7**

**INITIAL SETUP**

Tools:	Materials/Parts:	Personnel Required:
Tool Kit, Electronic Equipment Maintenance Kit, Printed Circuit	None	1

Use ESD precautionary procedures when handling, removing, or replacing BNC connector A2J1.

**REMOVAL**

1. Unsolder lead from terminal (not shown) of back side of BNC connector (4) adjacent to upper antenna mount (1).
2. Loosen and remove nut and washer on bottom of BNC connector (4).
3. Grasp BNC connector (4) from top and pull upward, separating connector and preform packing (5) from amplifier/coupler housing (7).

**REPLACEMENT**

1. Inspect preform packing O-ring (5). Replace if worn or cracked. Lubricate preform packing.
2. Align BNC connector (4) and preform packing (5) with hole adjacent to antenna mount.
3. Push BNC connector (4) and preform packing (5) into position with connector soldering terminal extending downward.
4. Screw on nut and washer and tighten.
5. Solder teflon wire from antenna select switch (8) to BNC connector terminal (4).

**ANTENNA SELECT SWITCH A2S1 REMOVAL AND REPLACEMENT, fig 5-7**

**INITIAL SETUP**

**Tools:**

Tool Kit, Electronic Equipment

**Materials/Parts:**

None

**Personnel Required:**

1

**WARNING**

De-energize equipment before removing or replacing the antenna select switch.

**CAUTION**

Use ESD precautionary procedures when handling, removing, or replacing antenna select switch A2S1.

**REMOVAL**

1. Working from the back side of antenna select switch (8), label and unsolder terminals 1, 3, 4,5, and 8.
2. Remove antenna select knob (2) by loosening 2 allen screws on side of knob.
3. Remove nut and lockwasher from threaded portion of antenna select switch (8).
4. Carefully pull antenna select switch downward, separating and removing switch from amplifier/coupler housing (7).

**REPLACEMENT**

1. Align antenna select switch (8) with appropriate hole in amplifier/coupler housing (7) and place into position with switch shaft extending upward and with threaded portion of shaft visible.
2. Attach lockwasher and nut.
3. Solder terminal connections 1, 3, 4, 5, and 8 located at base of antenna select switch (8).
4. Place antenna select knob (2) on antenna select switch shaft (8) and align with appropriate selection. Tighten 2 allen screws on side of knob.

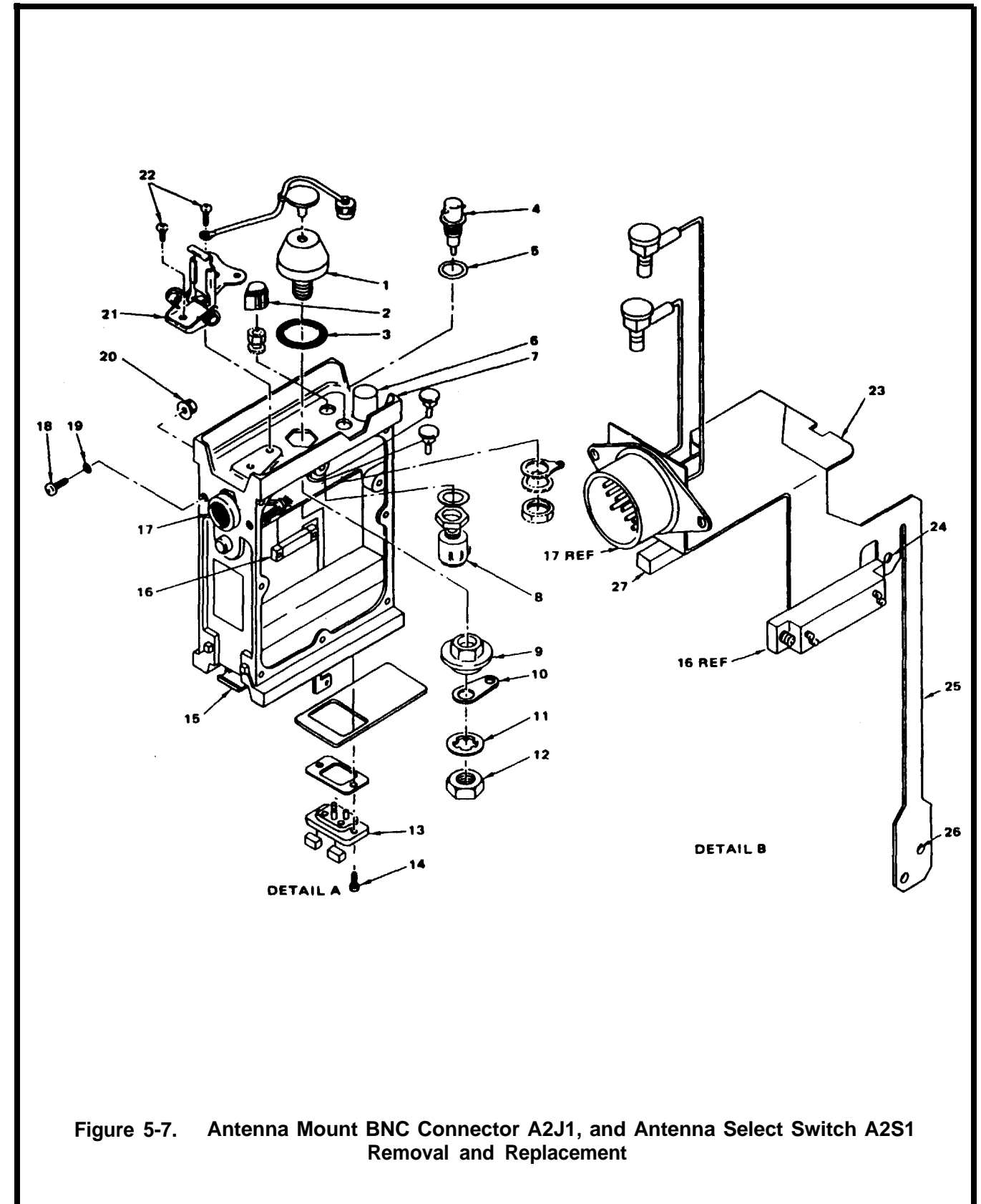

Figure 5-7. Antenna Mount BNC Connector A2J1, and Antenna Select Switch A2S1 Removal and Replacement

**GROUND A2E1 REMOVAL AND REPLACEMENT, fig 5-8**

**INITIAL SETUP**

**Tools:**

Tool Kit, Electronic Equipment

**Materials/Parts:**

None

**Personnel Required**

1

**WARNING**

De-energize equipment before removing or replacing ground A2E1.

**CAUTION**

Use ESD precautionary procedures when handling, removing, or replacing ground A2E1.

**REMOVAL**

1. Working from back side of ground connector (2) adjacent to antenna select knob (1) loosen and remove nut and washer.
2. Grasp top of connector ground (2) and pull upward, removing ground from amplifier/coupler housing (3).

**REPLACEMENT**

1. Align connector ground (2) and place in appropriate hole with threaded portion extending downward.
2. Attach washer and nut to threaded portion of connector ground (2).

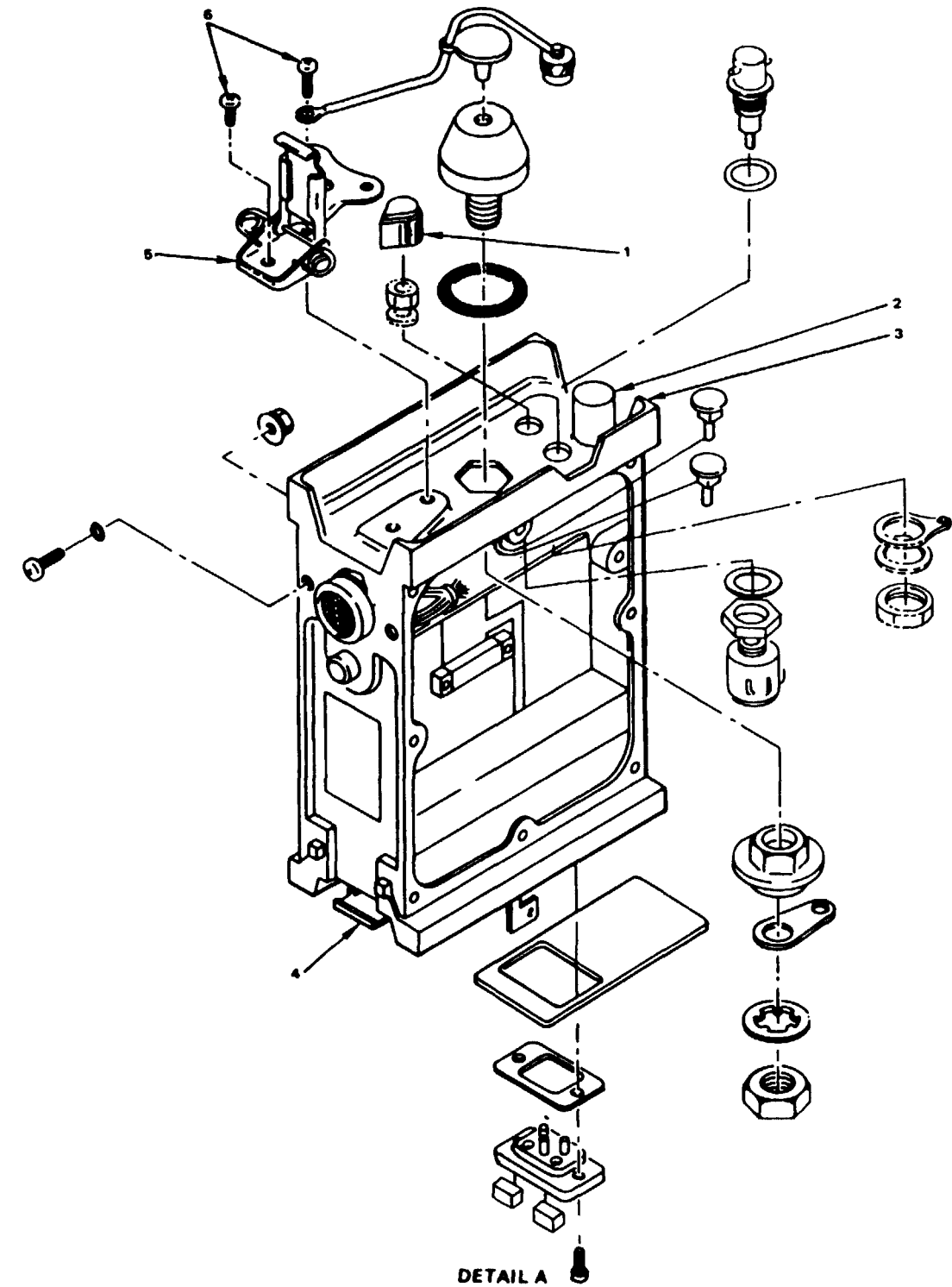

Figure 5-8. Ground A2E1 and Latch Removal and Replacement



**LATCH REMOVAL AND REPLACEMENT, fig 5-8**

**INITIAL SETUP**

**Tools:**

Tool Kit, Electronic Equipment

**Materials/Parts:**

None

**Personnel Required:**

1

**REMOVAL**

1. Remove latch (5) by loosening and removing 2 allen screws (6). Use same procedure for removing bottom latch (4).

**REPLACEMENT**

1. Place amplifier/coupler housing so control knobs face upward.
2. Align latch (5) with raised portion of amplifier/coupler housing (3).
3. insert 2 allen screws (6) and tighten.
4. Use same procedures for replacing bottom latch (4).

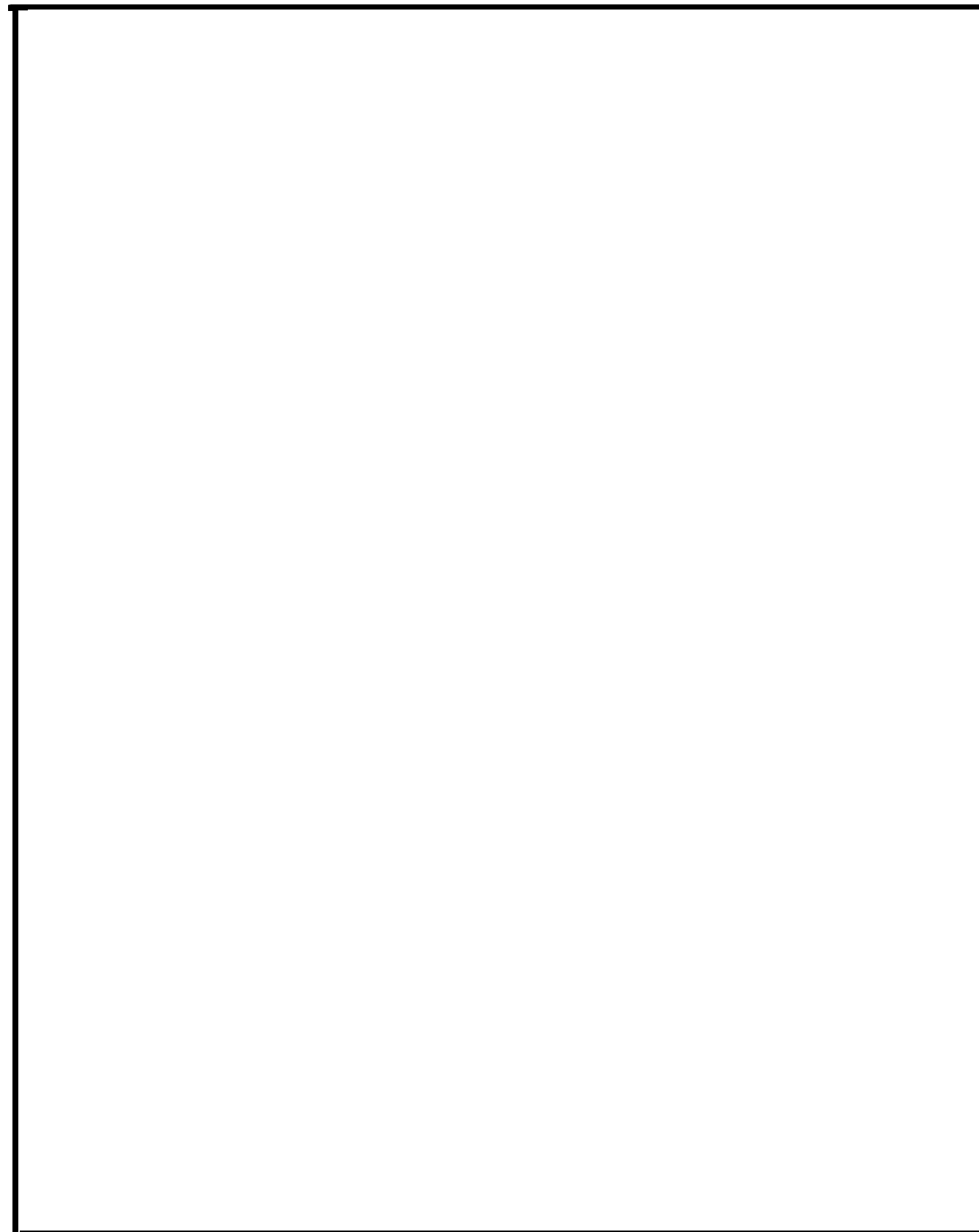

BLANK  
INTENTIONALLY

**MARINE CORPS ONLY**  
**CHAPTER 6**  
**RT DEPOT MAINTENANCE**

**Section I. RT FAULT ISOLATION**

	Page		Page
General .....	6-1	Special Tools and Test Equipment .....	6-23
EFP Fault Isolation .....	6-2	Performance Test Setup .....	6-23
Special Tools and Test Equipment .....	6-2	Performance Test .....	6-24
Performance Test Setup .....	6-2	Synthesizer Fault Isolation .....	6-25
Performance Test .....	6-3	Special Tools and Test Equipment .....	6-25
Modulator/Demodulator Fault Isolation .....	6-8	Performance Test Setup .....	6-25
Special Tools and Test Equipment .....	6-8	Performance Test .....	6-26
Performance Test Setup .....	6-9	Alignment Procedure .....	6-30
Performance Test .....	6-10	Harmonic Filter Fault Isolation .....	6-31
Alignment Procedure .....	6-17	Special Tools and Test Equipment .....	6-31
First Frequency Converter Fault isolation .....	6-19	Performance Test Setup .....	6-31
Special Tools and Test Equipment .....	6-19	Performance Test .....	6-32
Performance Test Setup .....	6-19	Alignment Procedure .....	6-36
Performance Test .....	6-20	Power Supply Fault Isolation .....	6-39
Second Frequency Converter Fault isolation .....	6-21	Special Tools and Test Equipment .....	6-39
Special Tools and Test Equipment .....	6-21	Performance Test Setup .....	6-40
Performance Test Setup .....	6-21	Performance Test .....	6-41
Performance Test .....	6-22	Alignment Procedure .....	6-43
Third Frequency Converter Fault Isolation .....	6-23		

**GENERAL**

This section contains information required to enable the technician to locate malfunctions in the components of the RT modules. Fault isolation procedures consist of special tools and test equipment, performance test setup, performance test, and, in some cases, alignment procedure. Fault isolation procedures are provided for the EFP, modulator/demodulator, harmonic filter, and power supply. The procedure for the modulator/demodulator is further divided into fault isolation procedures for the first, second, and third frequency converters.

**NOTE**

All measurements in the fault isolation and alignment procedures are taken with respect to chassis ground, unless otherwise specified.

**EFP FAULT ISOLATION**

**EFP FAULT ISOLATION SPECIAL TOOLS AND TEST EQUIPMENT**

Description	Part Number
Tool Kit, Electronic	TK-105/G
Bench Repair Center	Pace PRC-350C
Maintenance Kit, Printed Circuit	MK-9841A
Radio Set, Teat Bed	AN/PRC-104
Digital Multimeter (DVM, ohmmeter function)	
Power Supply DC	
Oscilloscope	
Spectrum Analyzer, Mainframe	
Signal Generator, RF	

**NOTE**

Refer to page 1-6 for test equipment characteristics.

**EFP FAULT ISOLATION PERFORMANCE TEST SETUP**

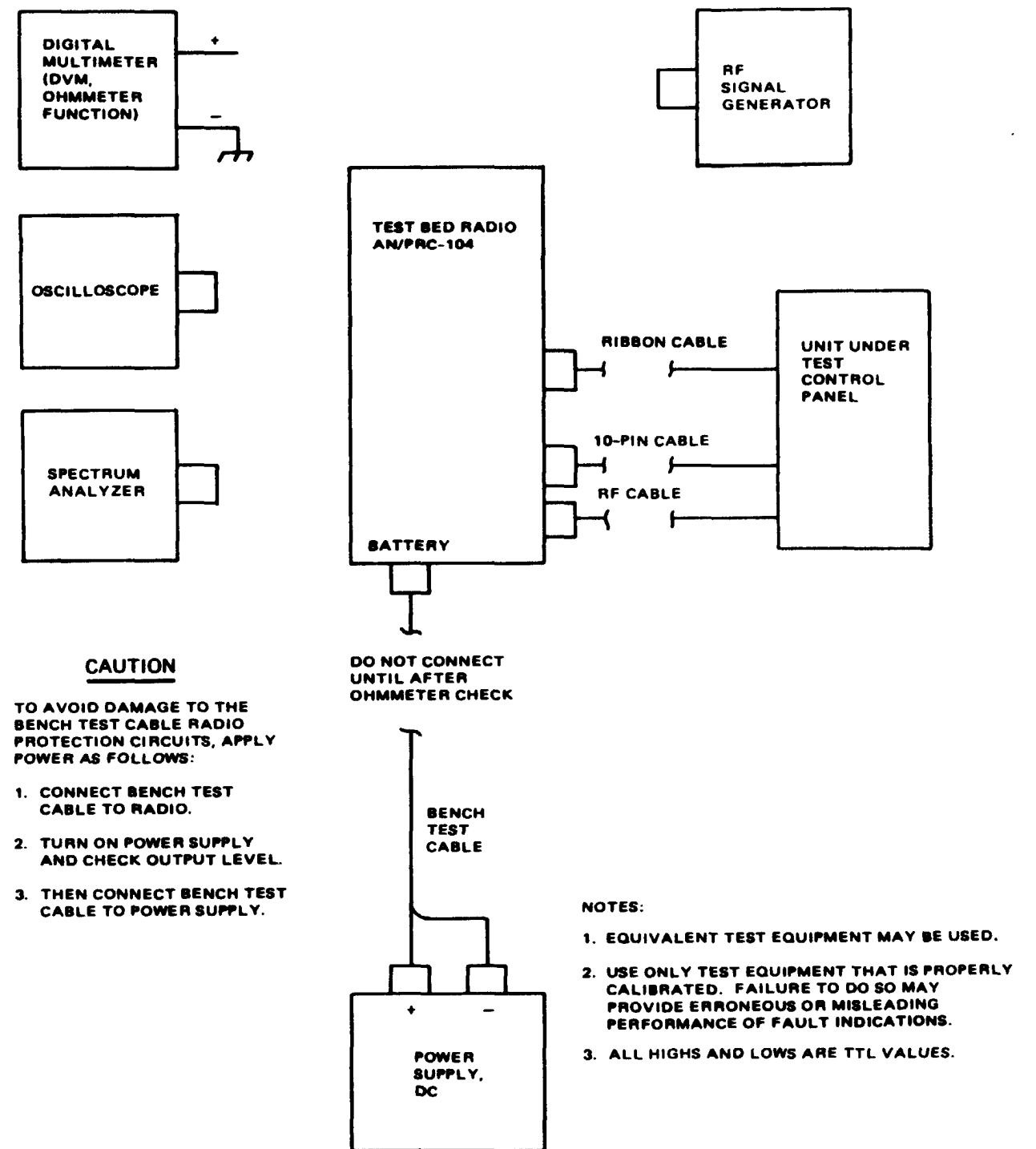
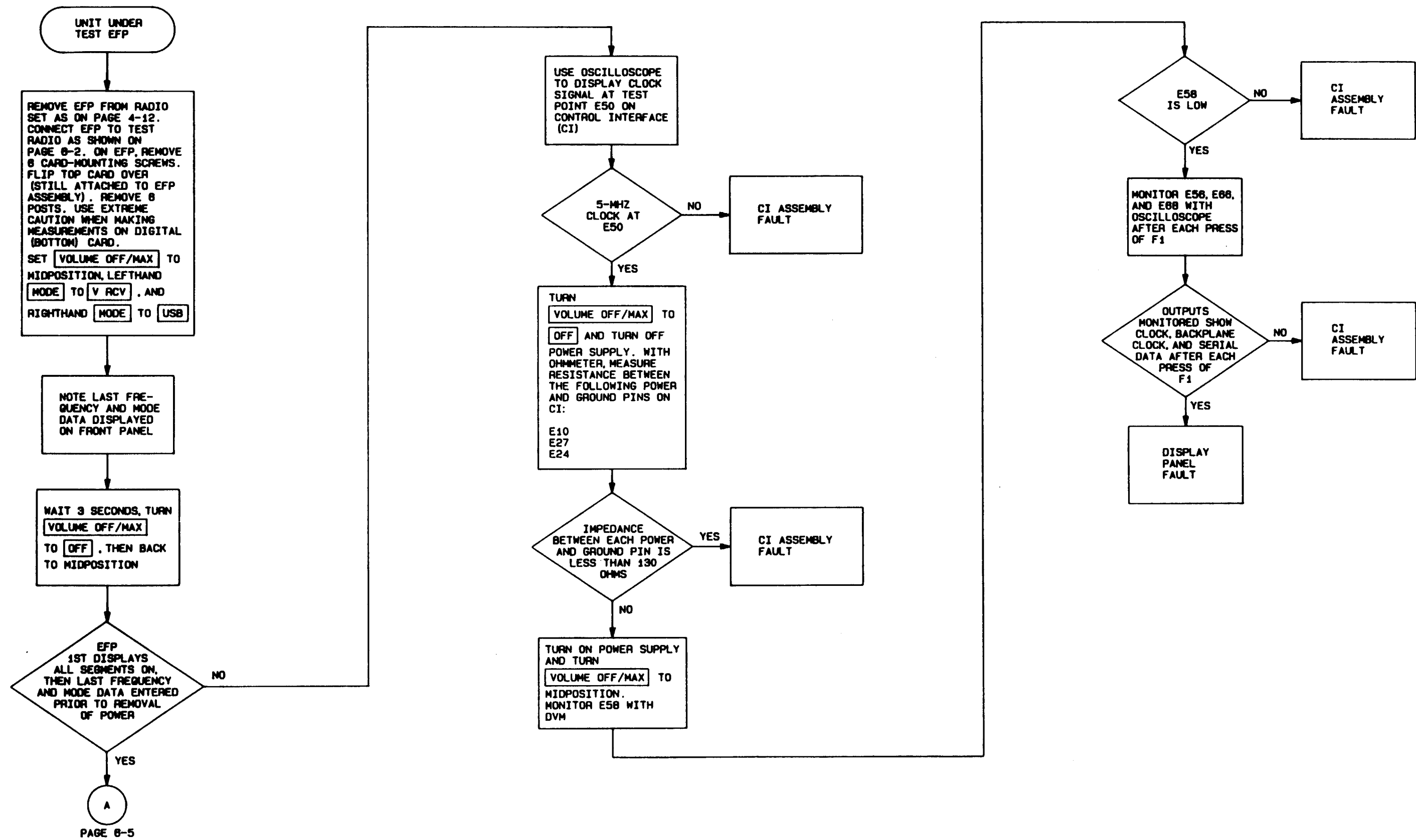

Figure 6-1. EFP Fault Isolation Performance Test Setup

**EFP FAULT ISOLATION PERFORMANCE TEST (1 of 5)**



**EFP FAULT ISOLATION PERFORMANCE TEST (2 of 5)**

**NOTE**

0 means low, 1 means high.

EFP DISPLAY FOR F1 AND F2

EFP Display		J1					
F1	F2	02	07	14	16	03	05
0	2	0	1	1	1	1	1
0	3	1	0	1	1	1	1
0	5	1	1	0	1	1	1
0	8	1	1	1	0	1	1
1	2	1	1	1	1	0	1
2	0	1	1	1	1	1	0

EFP DISPLAY FOR F1

EFP Display	J1	
F1	18	04
1	0	1
2	1	0
0	0	0

EFP DISPLAY FOR F2

EFP Display	J1			
F2	17	01	06	13
1	0	0	0	1
2	0	0	1	1
3	0	0	1	1
4	0	1	0	0
5	0	1	0	1
6	0	1	1	0
7	0	1	1	1
8	1	0	0	0
9	1	0	0	1
0	0	0	0	0

EFP DISPLAY FOR F3

EFP Display	J1			
F3	35	25	26	28
1	0	0	0	1
2	0	0	1	1
3	0	0	1	1
4	0	1	0	0
5	0	1	0	1
6	0	1	1	0
7	0	1	1	1
8	1	0	0	0
9	1	0	0	1
0	0	0	0	0

EFP DISPLAY FOR F4

EFP Display	J1			
F4	34	23	24	29
1	0	0	0	1
2	0	0	1	1
3	0	0	1	1
4	0	1	0	0
5	0	1	0	1
6	0	1	1	0
7	0	1	1	1
8	1	0	0	0
9	1	0	0	1
0	0	0	0	0

EFP DISPLAY FOR F5

EFP Display	J1			
F5	32	20	22	31
1	0	0	0	1
2	0	0	1	1
3	0	0	1	1
4	0	1	0	0
5	0	1	0	1
6	0	1	1	0
7	0	1	1	1
8	1	0	0	0
9	1	0	0	1
0	0	0	0	0

EFP DISPLAY FOR F6

EFP Display	J1			
F6	33	19	21	30
1	0	0	0	1
2	0	0	1	1
3	0	0	1	1
4	0	1	0	0
5	0	1	0	1
6	0	1	1	0
7	0	1	1	1
8	1	0	0	0
9	1	0	0	1
0	0	0	0	0

DATA/VOICE AND TX/RX MODE DISPLAY

M1	J1	
	46	51
V RCV	0	0
VTR	0	1
D RCV	1	0
DTR	1	1

**EFP FAULT ISOLATION PERFORMANCE TEST (3 of 5)**

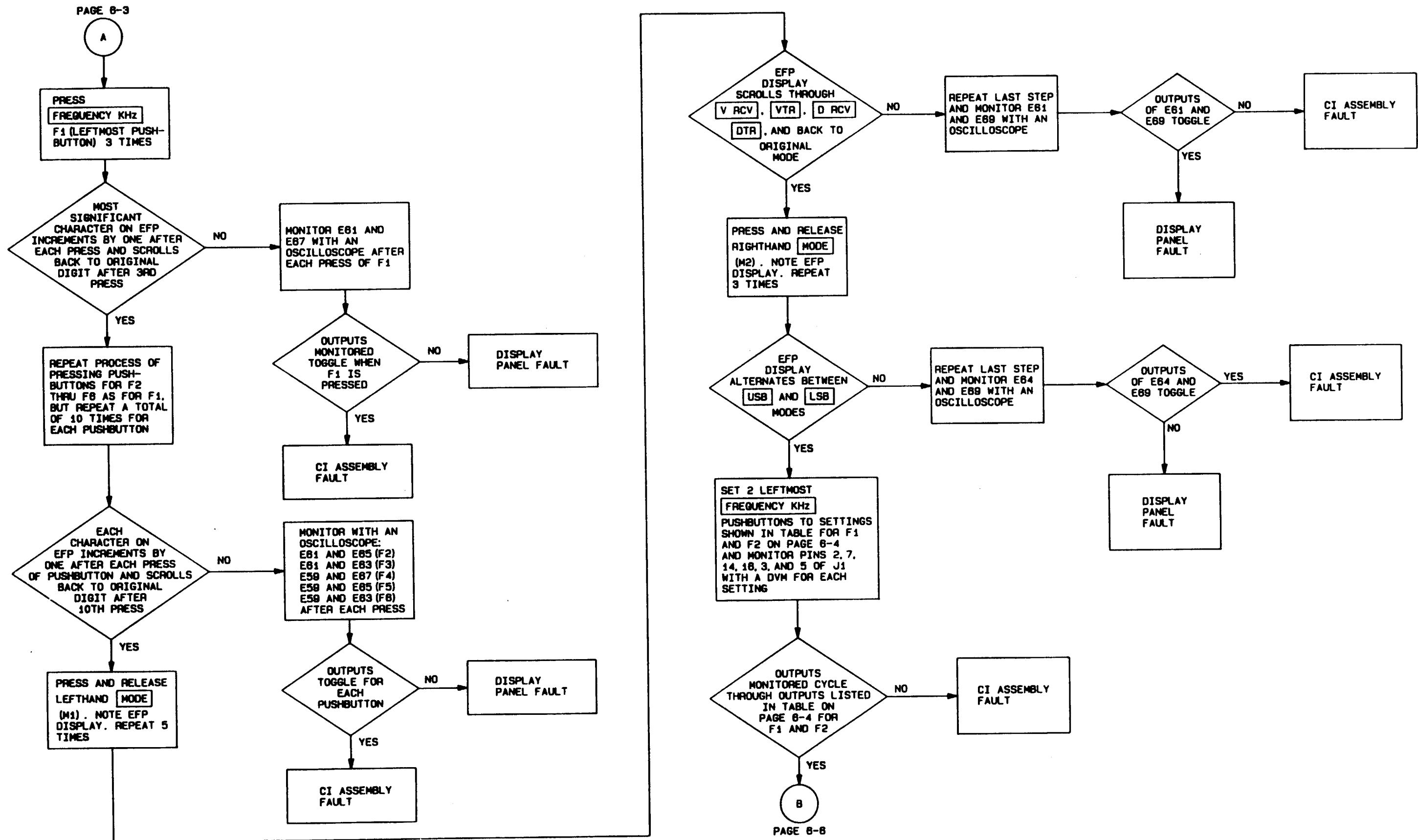

**EFP FAULT ISOLATION PERFORMANCE TEST (4 of 5)**

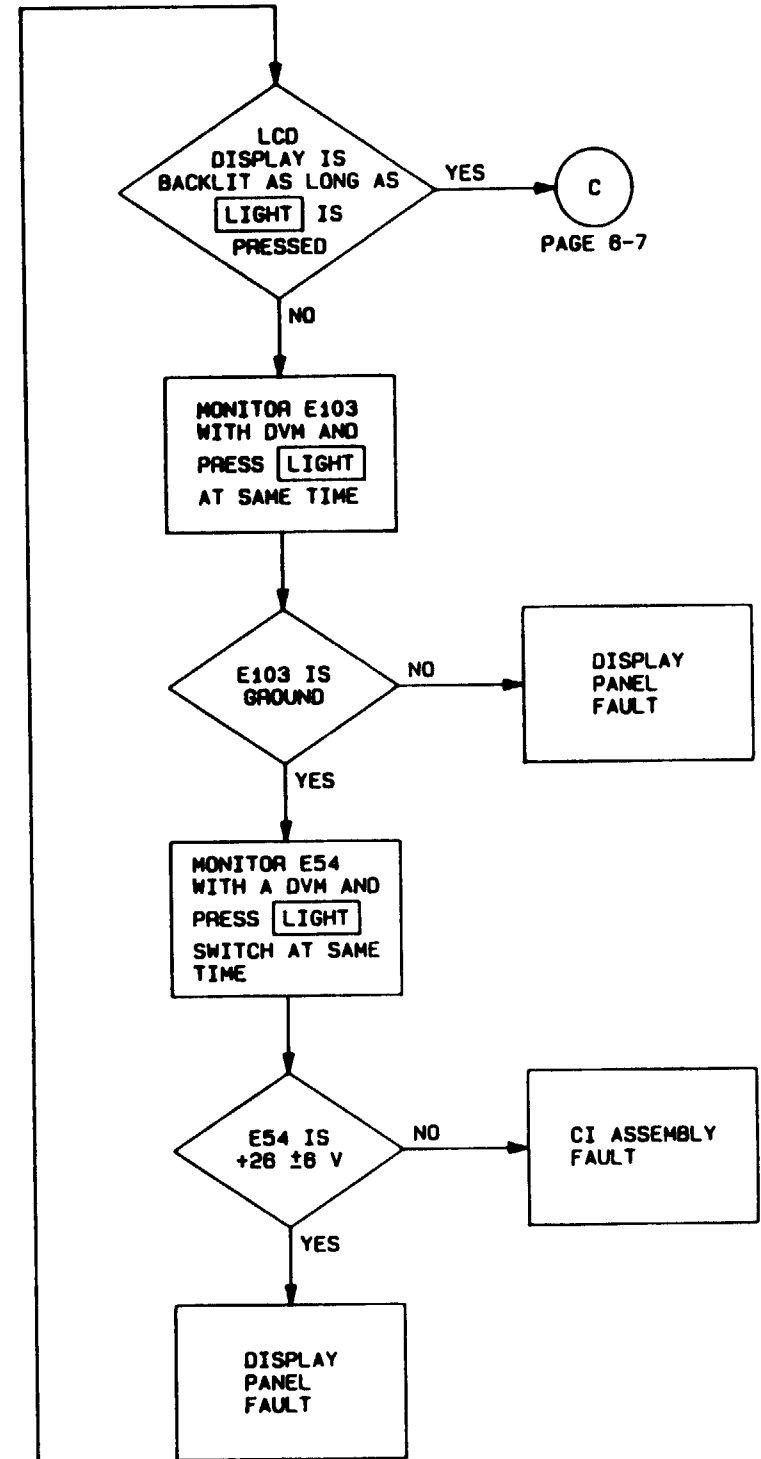
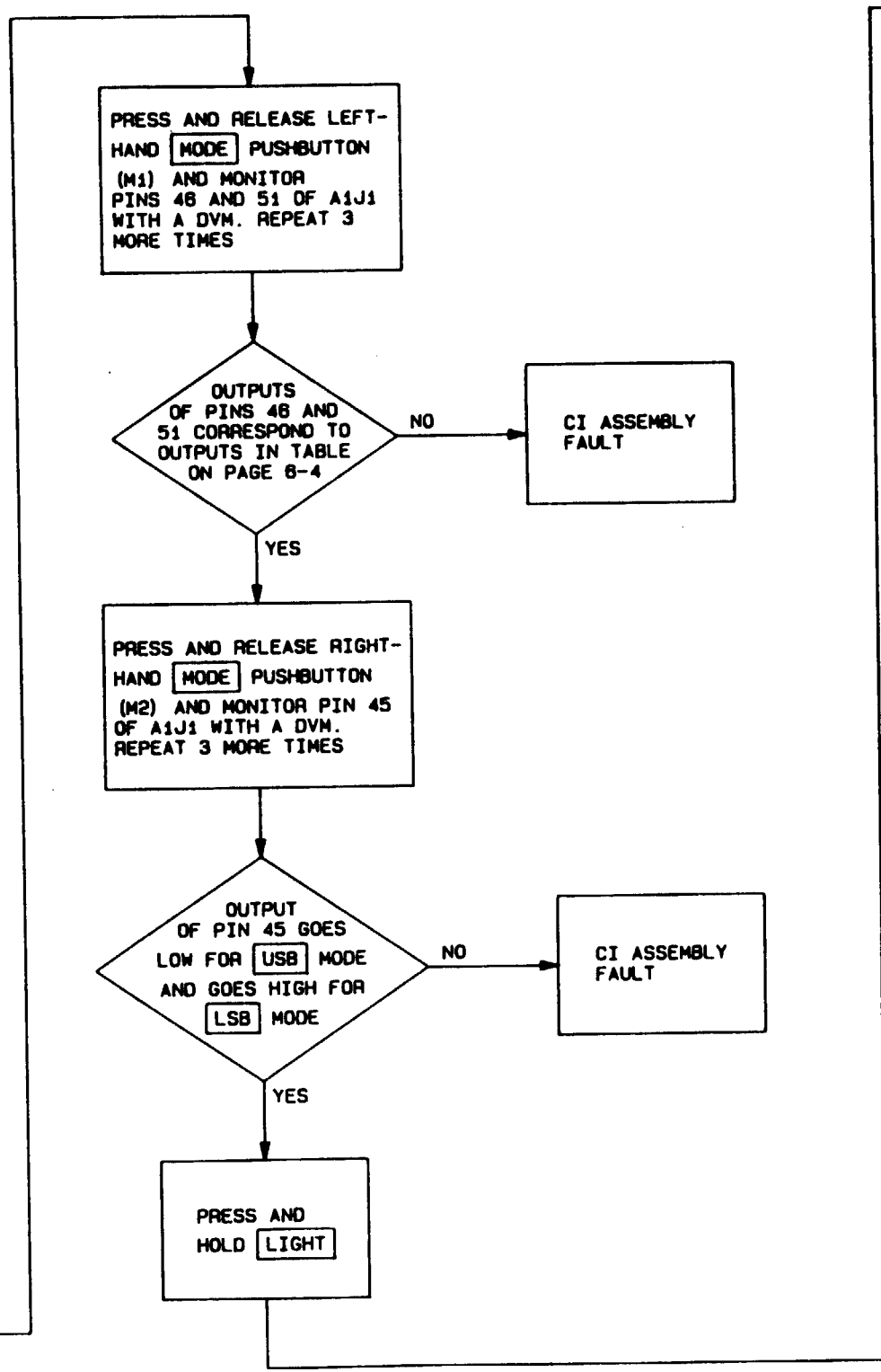
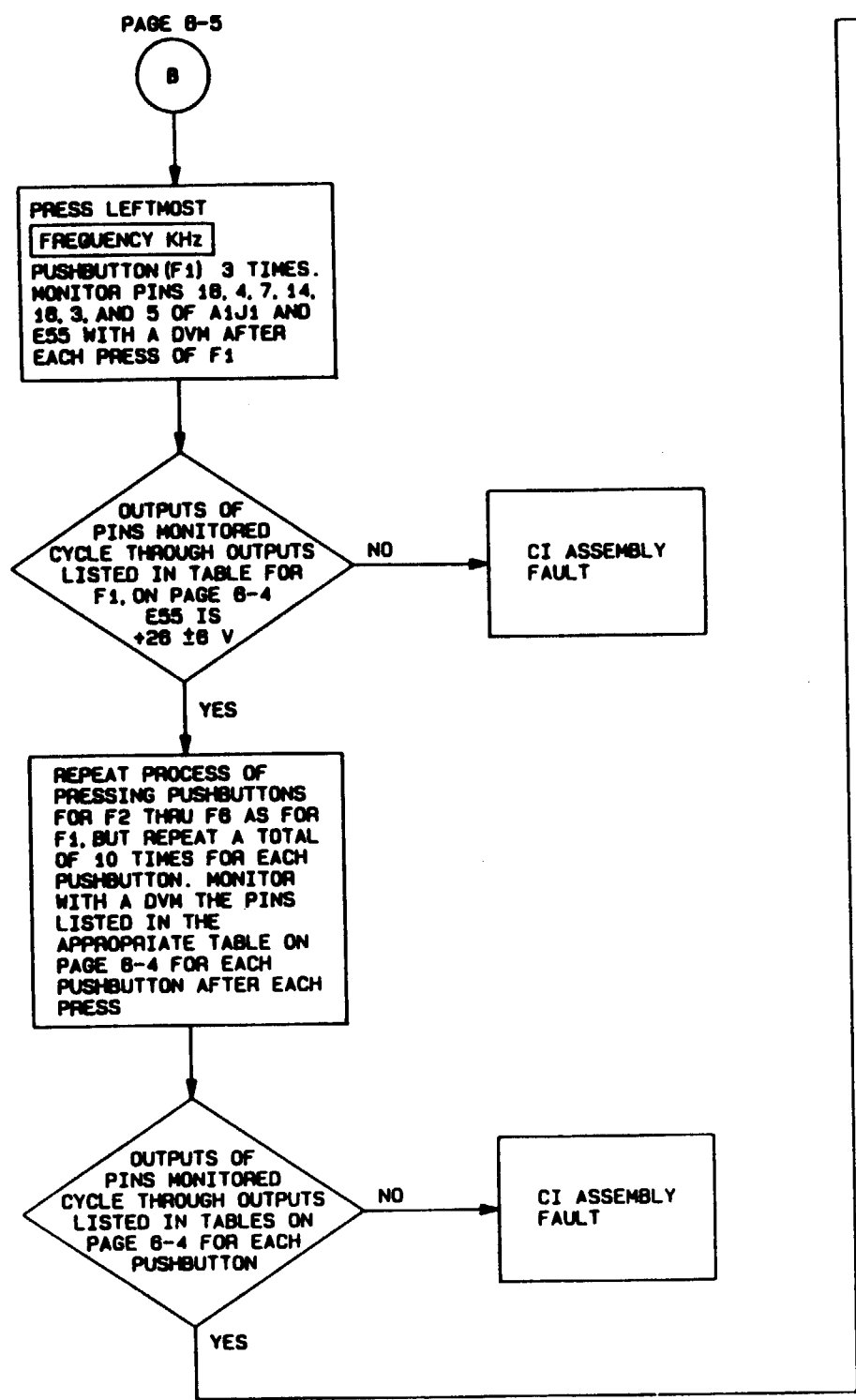



**EFP FAULT ISOLATION PERFORMANCE TEST (5 of 5)**

PAGE 6-6

C

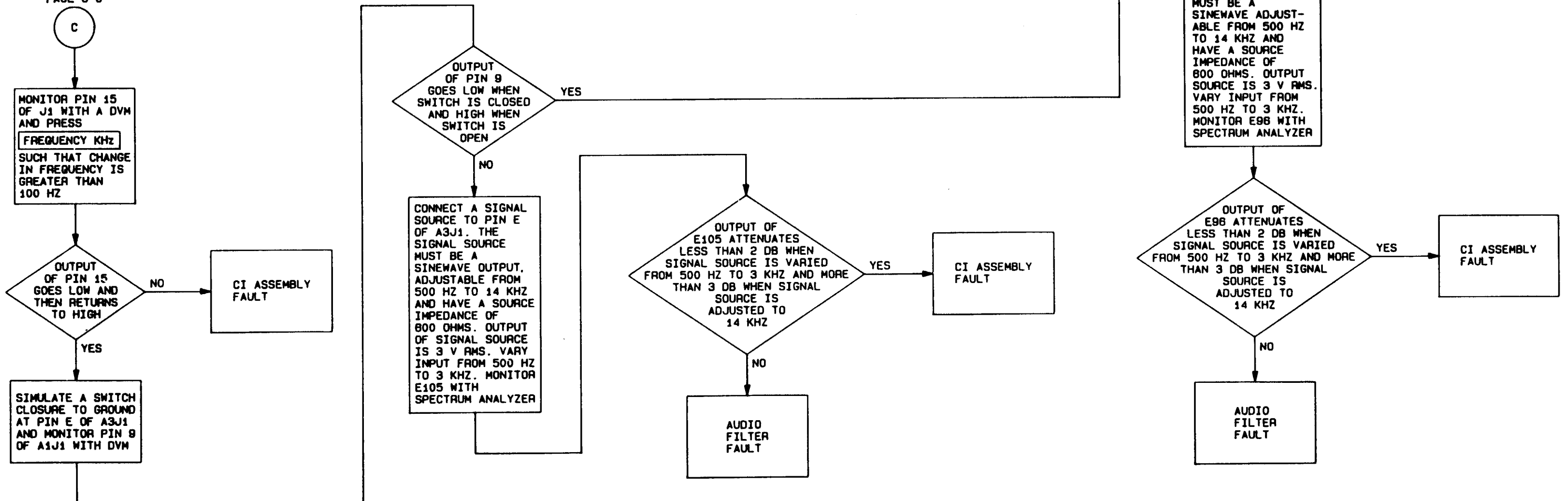

**MODULATOR/DEMODULATOR FAULT ISOLATION**

The modulator/demodulator fault isolation procedure is divided into the following: special tools and test equipment, performance test setup, and performance test.

**MODULATOR/DEMODULATOR FAULT ISOLATION SPECIAL TOOLS AND TEST EQUIPMENT**

Description	Part Number
Modulator/Demodulator Test Extender Cable	...
RF Coax Cable (3 each)	...
RF Extender Cable (3 each)	...
Audio Input/Keying Adapter	...
Tool Kit, Electronic	TK-105/G
Bench Repair Center	Pace PRC-350C
Maintenance Kit, Printed Circuit	MK-984/A
Radio Set, Test Bed	AN/PRC-104
Audio Oscillator	
VTVM	
Dummy Load (50 ohms)	
Signal Generator, RF	
Oscilloscope, Storage	
Digital Multimeter (DVM, ohmmeter function)	

Description	Part Number
Attenuator, Step 10-db steps, 0.5 W, 50 ohms	
Wattmeter	
— Power Meter	
— Thermocouple Power Sensor	
Spectrum Analyzer	
— High Resolution IF. Section	
— RF Section	
— Tracking Generator	
— High impedance Probe	
Distortion Analyzer	
Power Supply Current Limited	
Power Supply DC	
Attenuator, Coaxial 20 db, 30 W rein, 50 ohms (3 each)	
150-Ohm Resistor	...
500-Ohm Resistor	...
2000-Ohm Resistor	...

**NOTE**

Refer to page 1-6 for test equipment characteristics.

**MODULATOR/DEMODULATOR FAULT ISOLATION PERFORMANCE TEST SETUP**

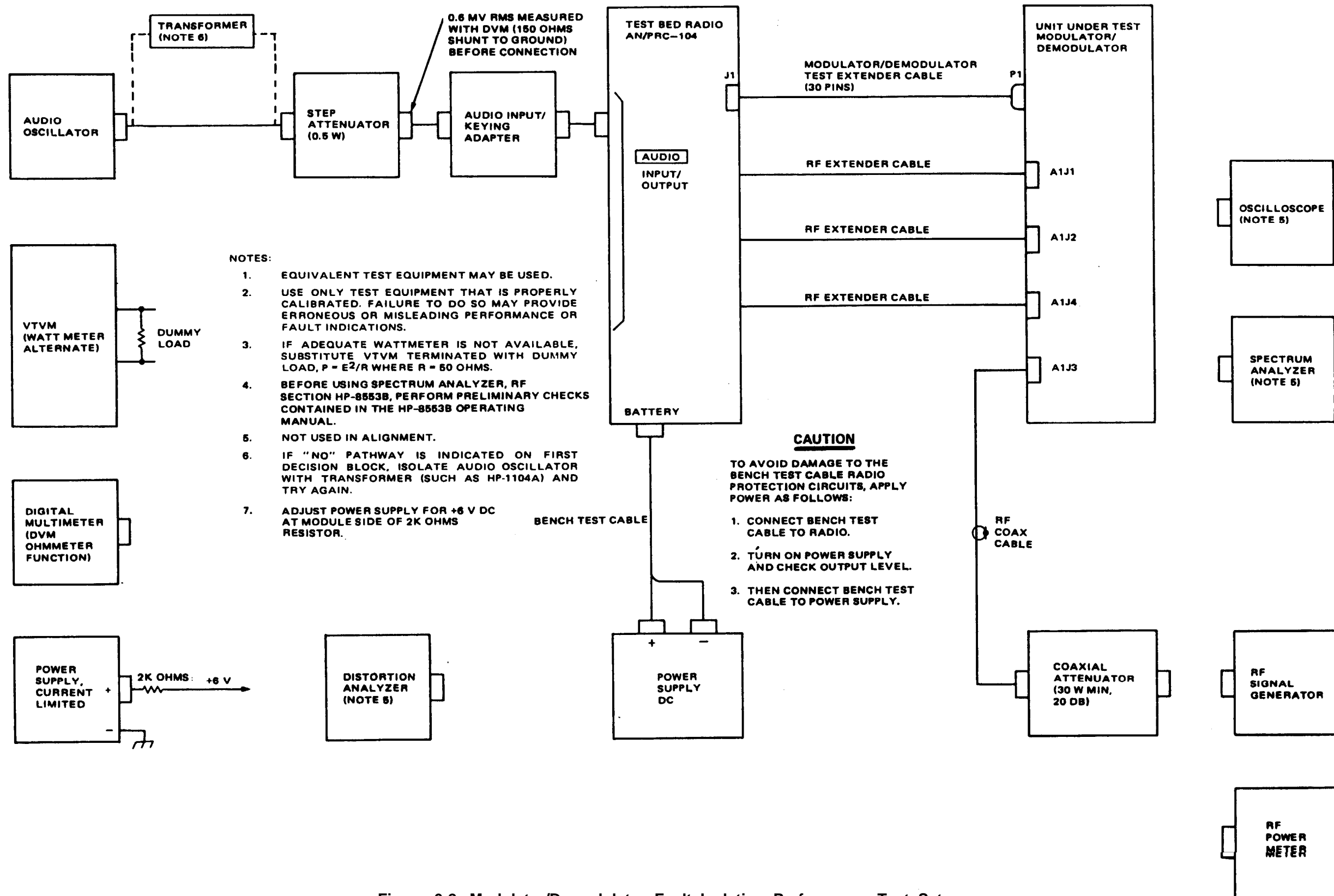
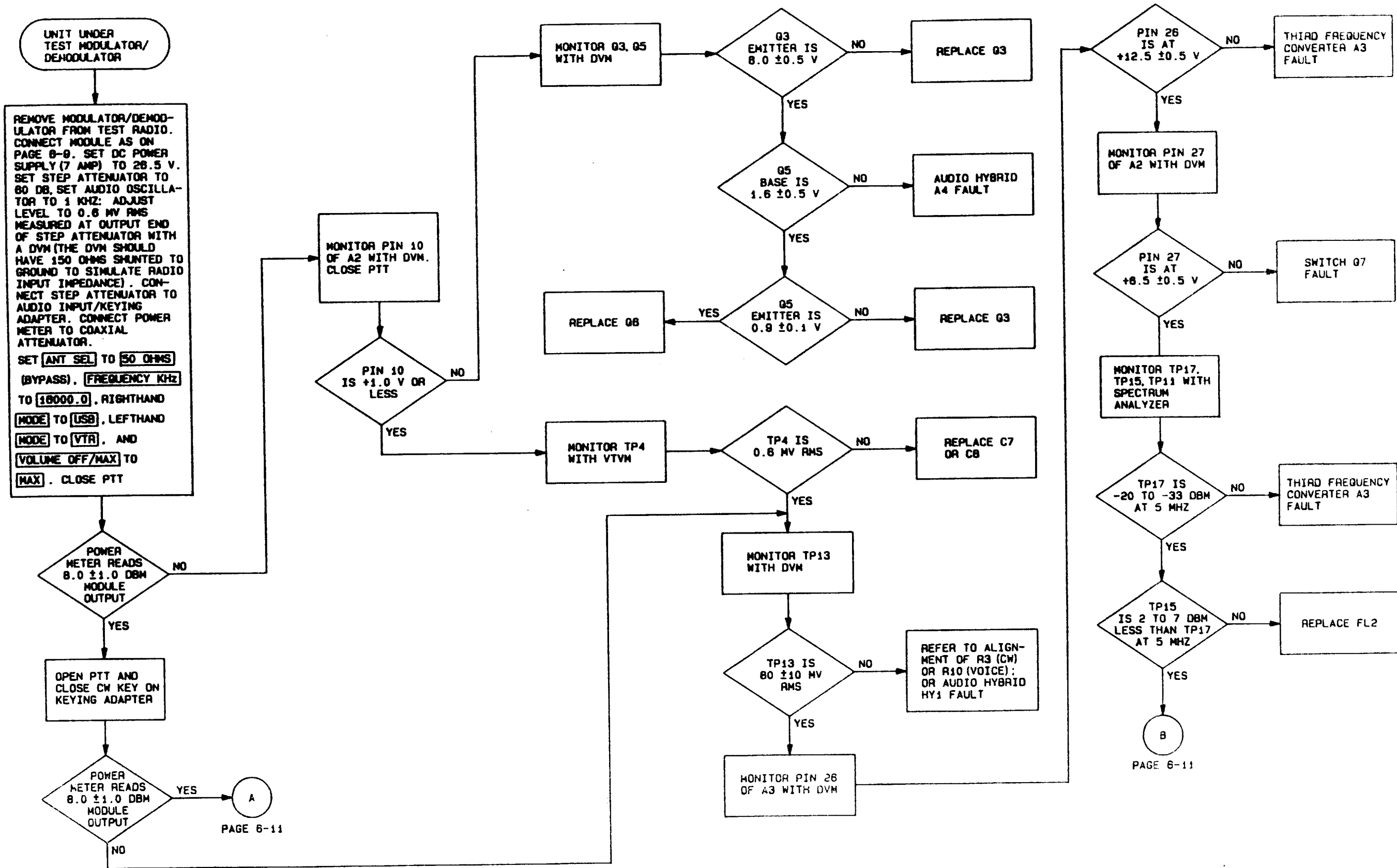
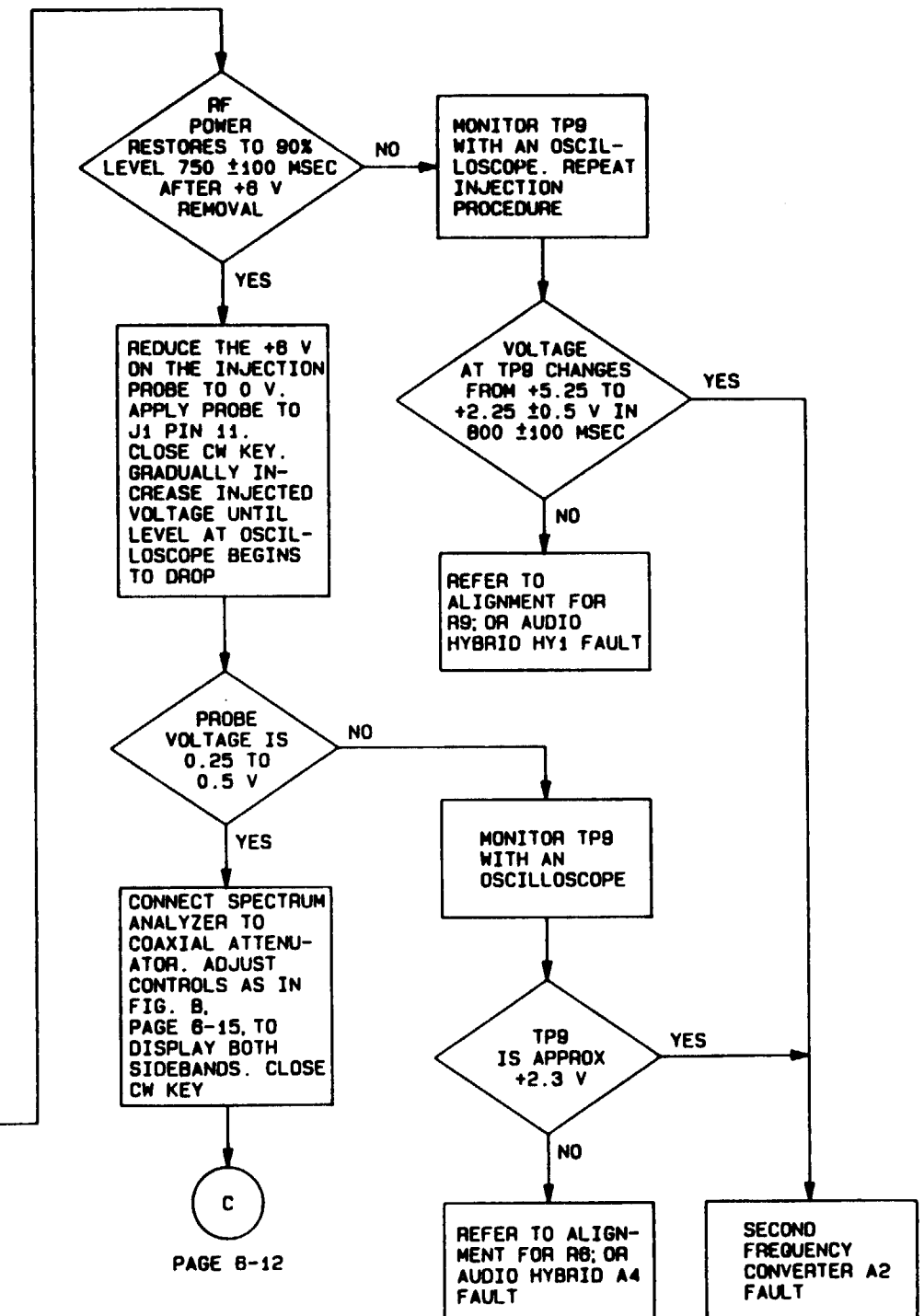
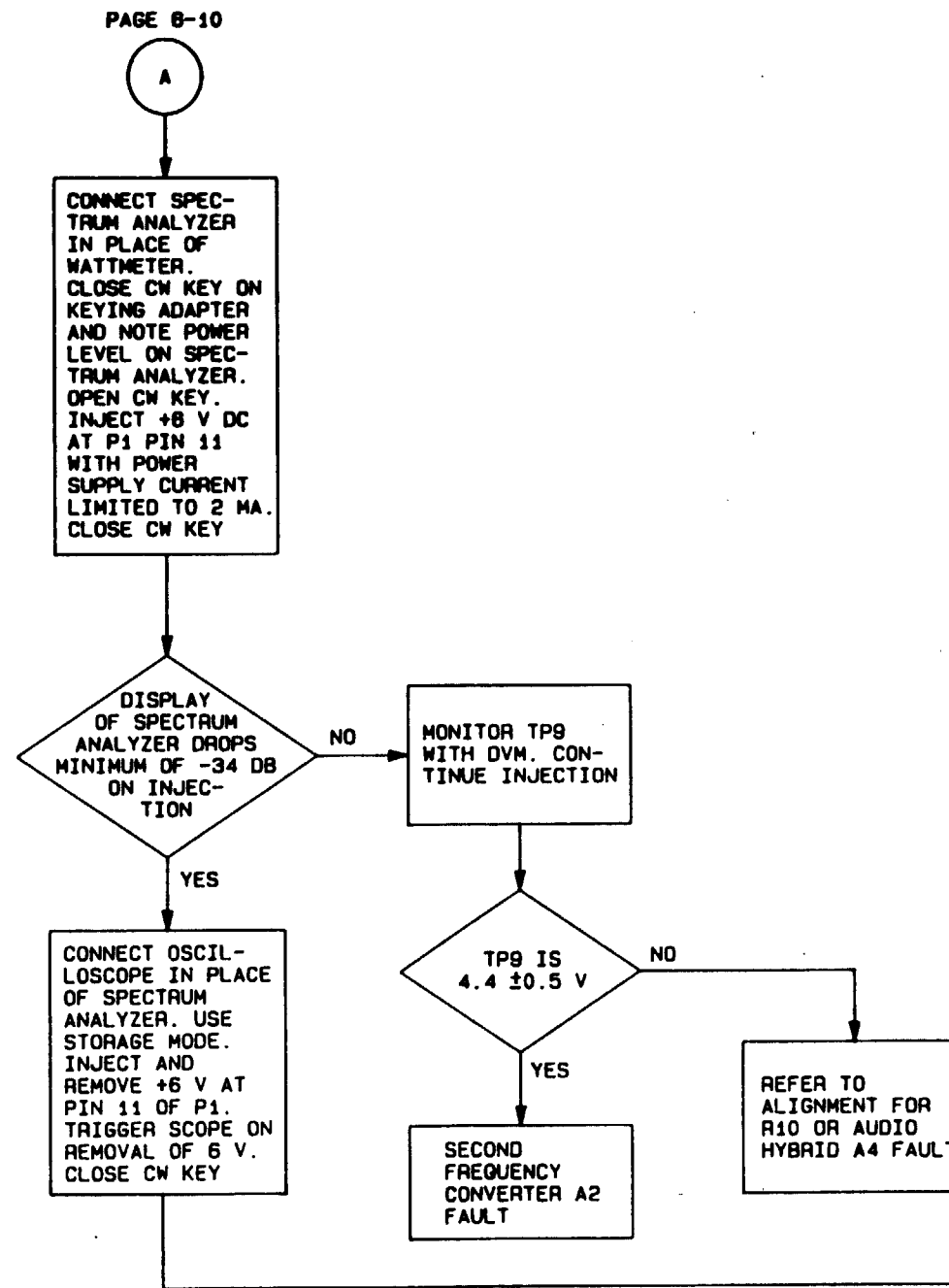
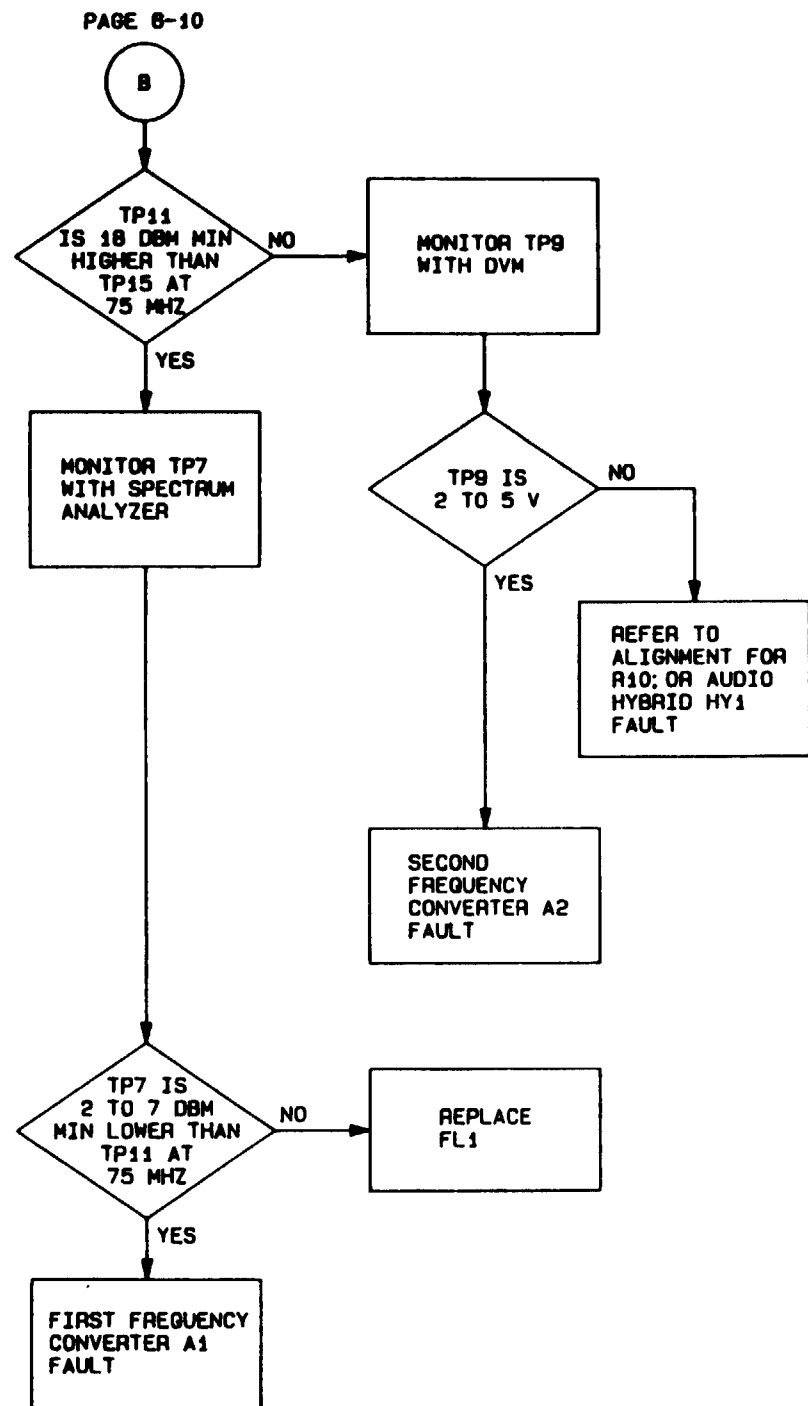

Figure 6-2. Modulator/Demodulator Fault Isolation Performance Test Setup

**MODULATOR/DEMODULATOR FAULT ISOLATION PERFORMANCE TEST (1 of 7)**



**MODULATOR/DEMODULATOR FAULT ISOLATION PERFORMANCE TEST (2 of 7)**



**MODULATOR/DEMODULATOR FAULT ISOLATION PERFORMANCE TEST (3 of 7)**

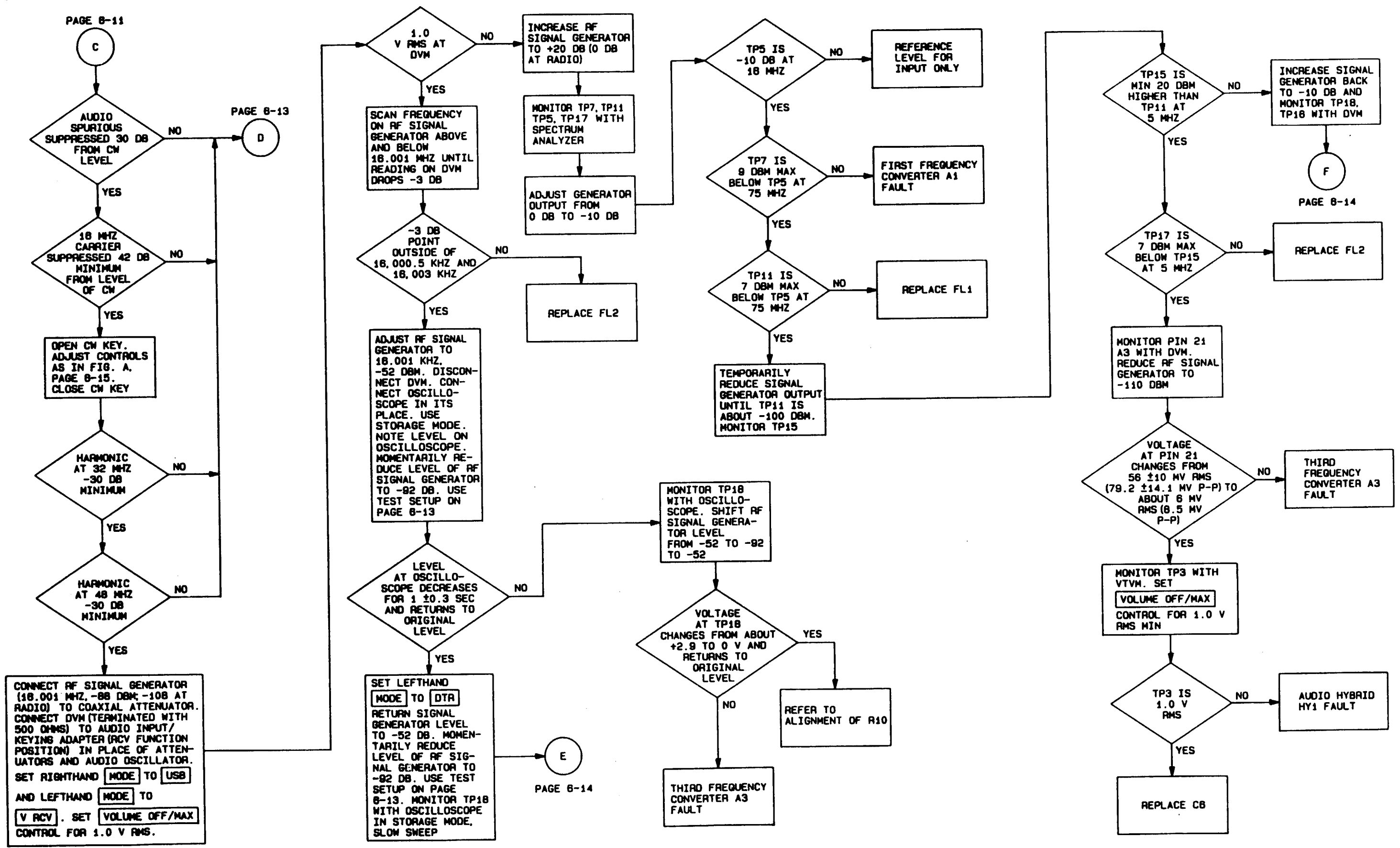

**MODULATOR/DEMODULATOR FAULT ISOLATION PERFORMANCE TEST (4 of 7)**

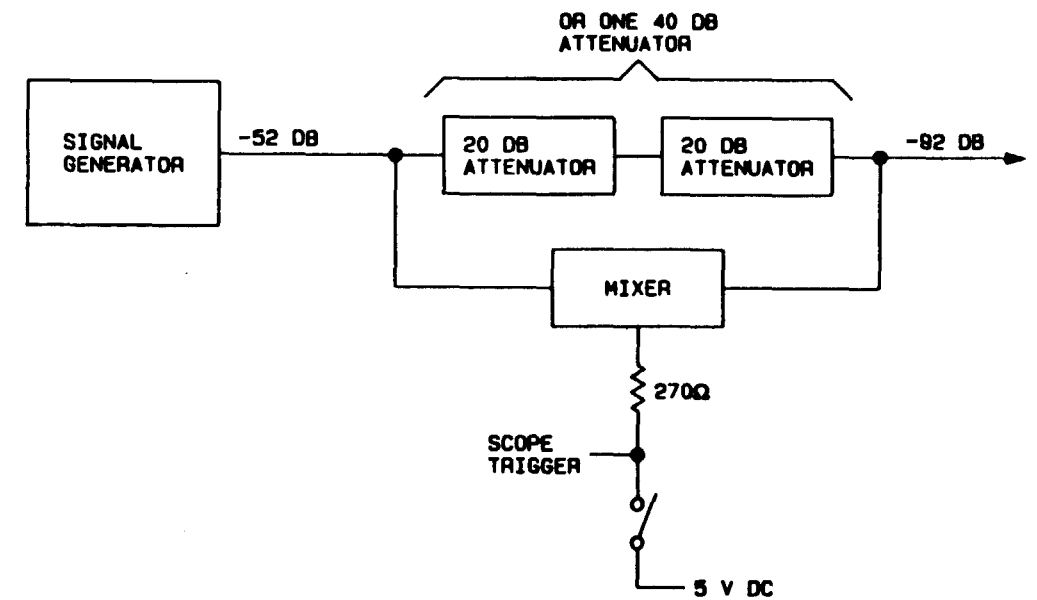
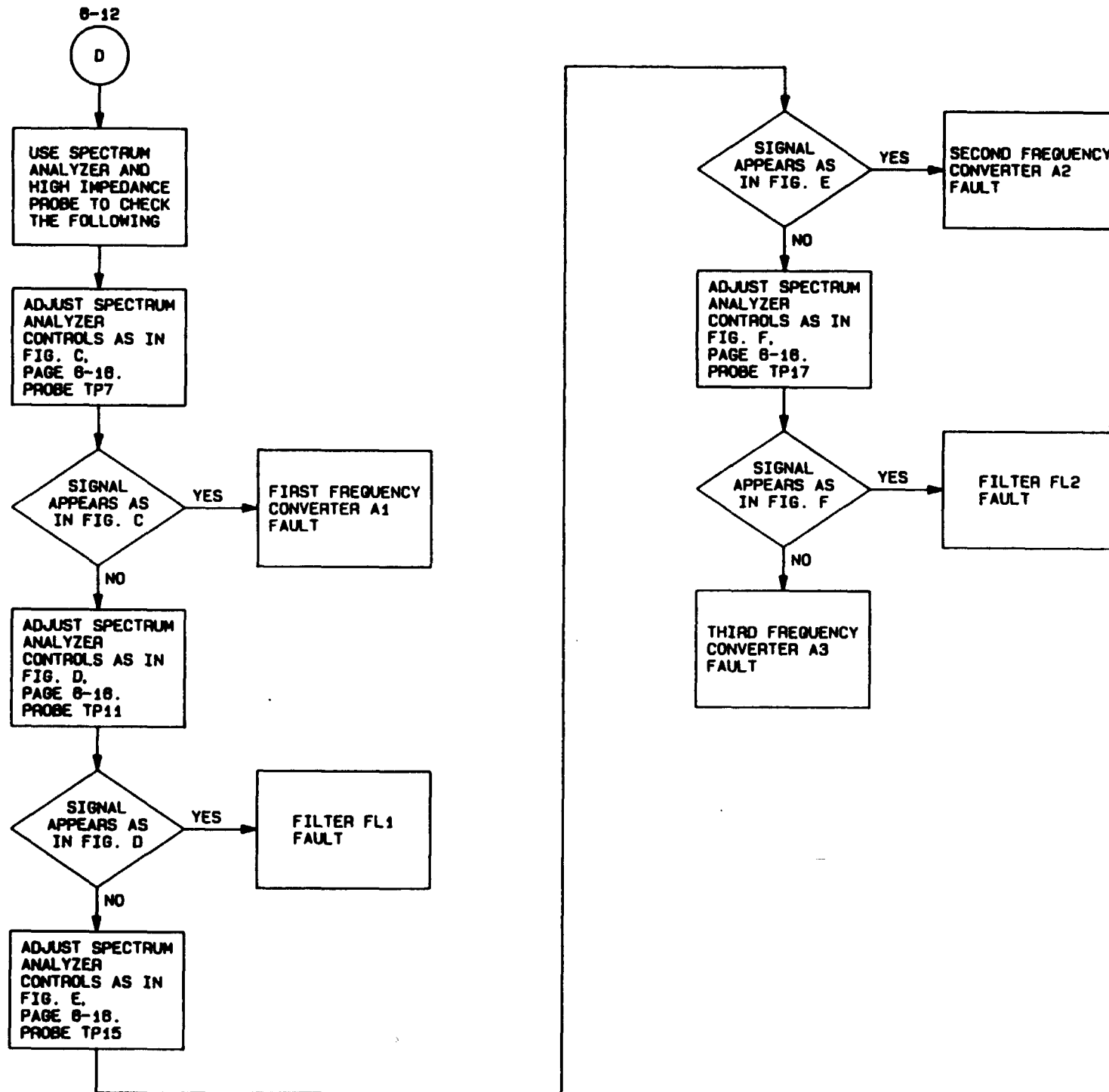

**MODULATOR/DEMODULATOR FAULT ISOLATION PERFORMANCE TEST (5 of 7)**

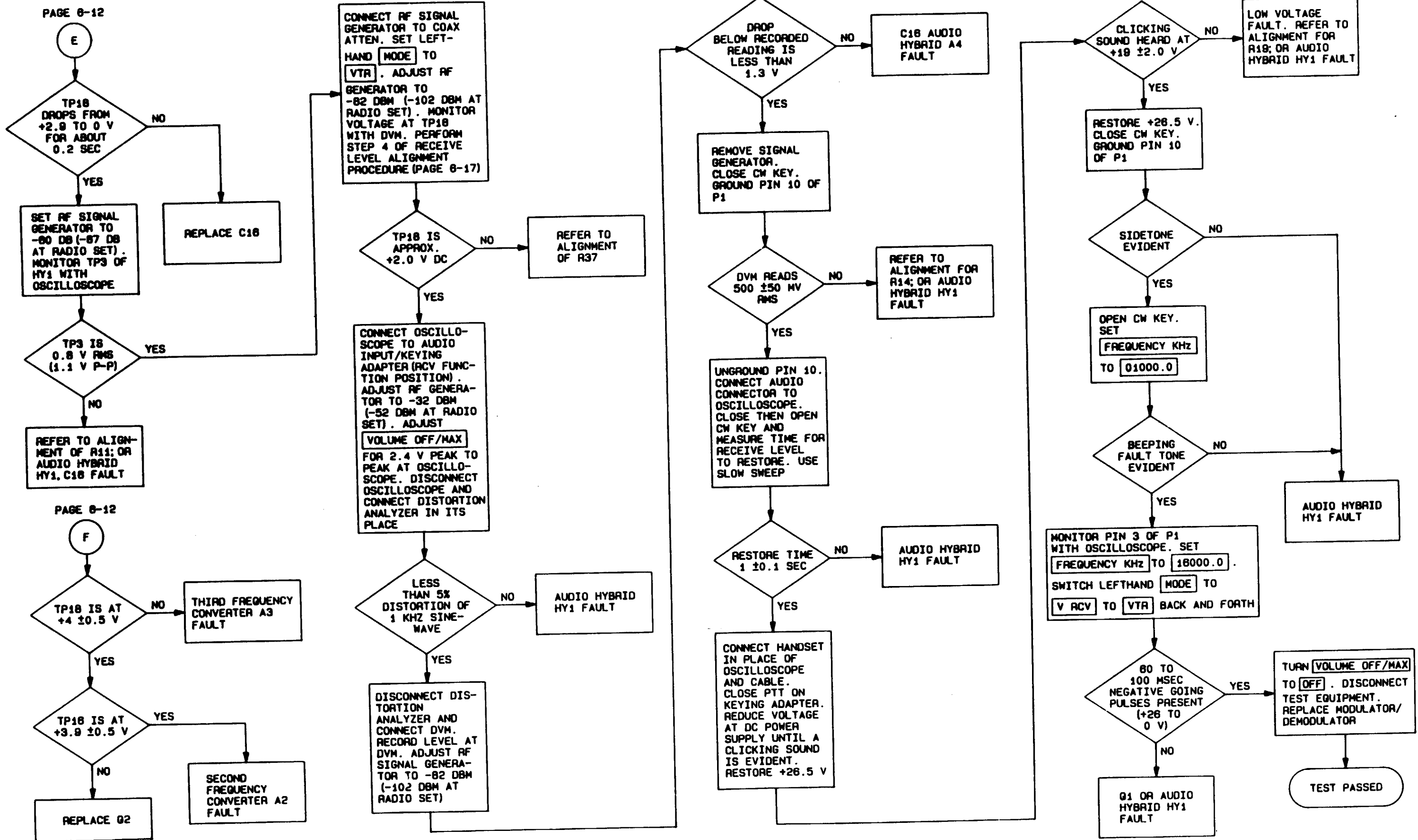



**MODULATOR/DEMODULATOR FAULT ISOLATION PERFORMANCE TEST (6 of 7)**

RESOLUTION BANDWIDTH 100 KHZ  
 SCAN WIDTH 10 MHZ PER CM  
 INPUT ATTEN. 40 DB  
 RANGE PER DIVISION  
 VIDEO FILTER 100 HZ  
 10 DB LOG  
 LOG REF +10  
 SCAN MODE SINGLE  
 LINEAR SENSITIVITY AS REQ'D  
 SCAN TRIGGER AUTO  
 CENTER FREQUENCY AS REQ'D  
 SCAN TIME 1 SECOND  
 STORAGE STANDARD  
 INTENSITY AS REQ'D  
 PERSISTENCE MAXIMUM

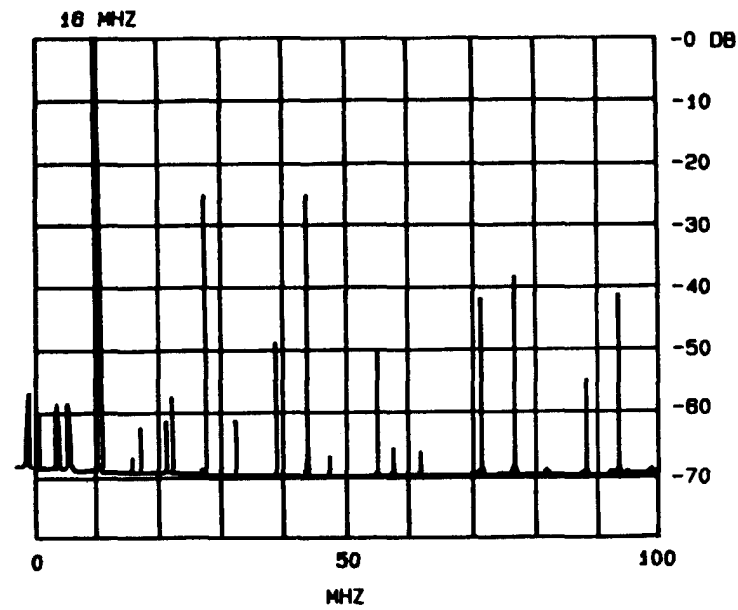

FIGURE A. HARMONIC CHARACTERISTICS OF THE MODULATOR/DEMODULATOR AT 18 MHZ

RESOLUTION BANDWIDTH 0.1 KHZ  
 SCAN WIDTH 1 KHZ/DIV.  
 INPUT ATTEN. 40 DB  
 SCAN TIME 2 SECONDS  
 RANGE PER DIVISION  
 10 DB LOG  
 LOG REF +10  
 SCAN MODE SINGLE  
 CENTER FREQUENCY 16.001  
 VIDEO FILTER 10 HZ  
 SCAN TRIGGER AUTO  
 LINEAR SENSITIVITY AS REQ'D  
 STORAGE STANDARD  
 INTENSITY AS REQ'D  
 PERSISTENCE MAXIMUM

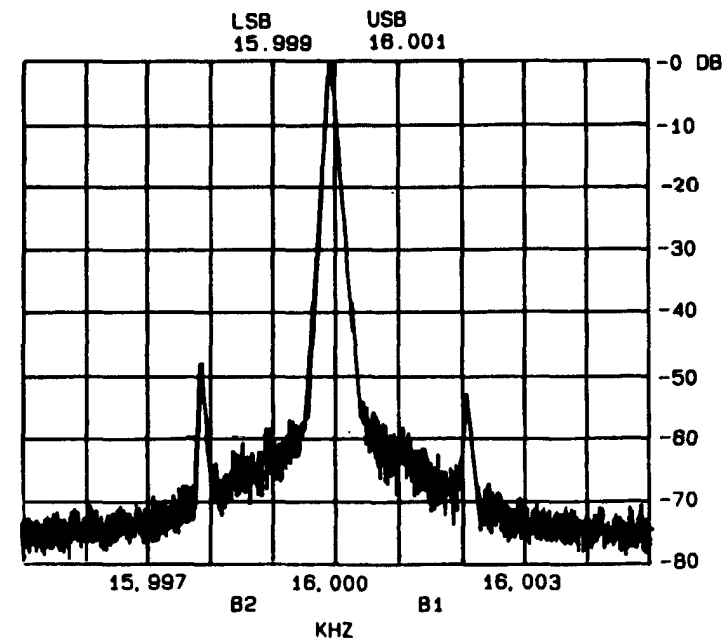

FIGURE B. B1-18 MHZ UPPER SIDEBAND, CENTER FREQUENCY 16.001 B2 - 15.999 MHZ LOWER SIDEBAND

NOTE: UNLESS OTHERWISE SPECIFIED

ALL VOLTAGE MEASUREMENTS  
 TAKEN WITH RESPECT TO  
 CHASSIS GROUND.

**MODULATOR/DEMODULATOR FAULT ISOLATION PERFORMANCE TEST (7 of 7)**

RESOLUTION BANDWIDTH 100 HZ  
 SCAN WIDTH 10 KHZ  
 INPUT ATTEN. 10 DB  
 SCAN TIME 3.0 SEC  
 RANGE PER DIVISION  
 VIDEO FILTER 3 KHZ  
 10 DB LOG  
 LOG REF +10  
 SCAN MODE SINGLE  
 CENTER FREQUENCY 74.99908 MHZ  
 LINEAR SENSITIVITY AS REQ'D  
 SCAN TRIGGER AUTO  
 STORAGE STANDARD  
 INTENSITY AS REQ'D  
 PERSISTENCE MAXIMUM

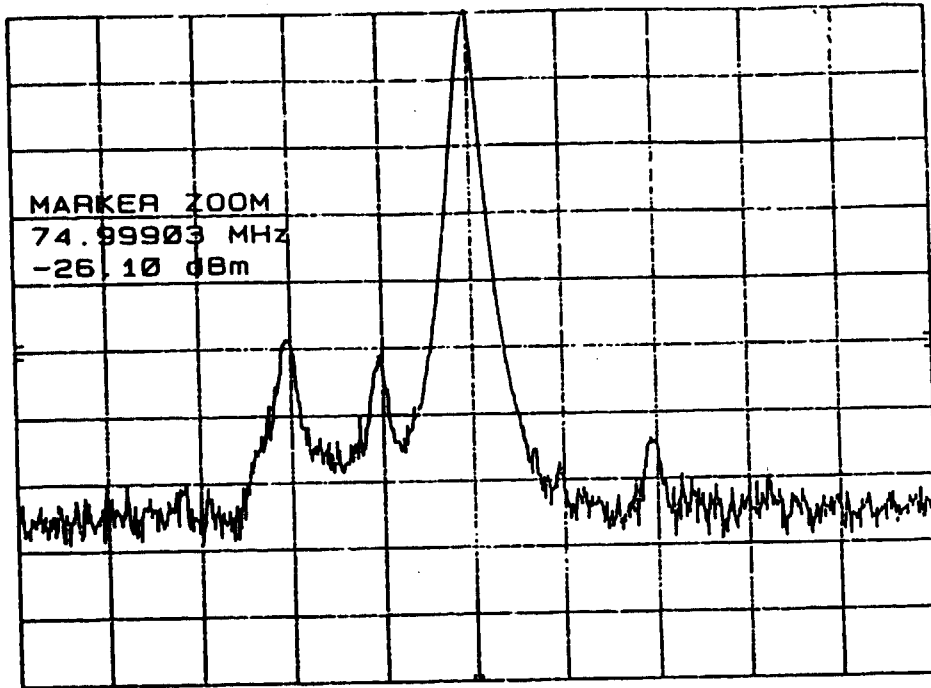

FIGURE C

RESOLUTION BANDWIDTH 100 HZ  
 SCAN WIDTH 10 KHZ  
 INPUT ATTEN. 10 DB  
 SCAN TIME 3.0 SEC  
 RANGE PER DIVISION  
 VIDEO FILTER 3 KHZ  
 10 DB LOG  
 LOG REF +10  
 SCAN MODE SINGLE  
 CENTER FREQUENCY 4.99902 MHZ  
 LINEAR SENSITIVITY AS REQ'D  
 SCAN TRIGGER AUTO  
 STORAGE STANDARD  
 INTENSITY AS REQ'D  
 PERSISTENCE MAXIMUM

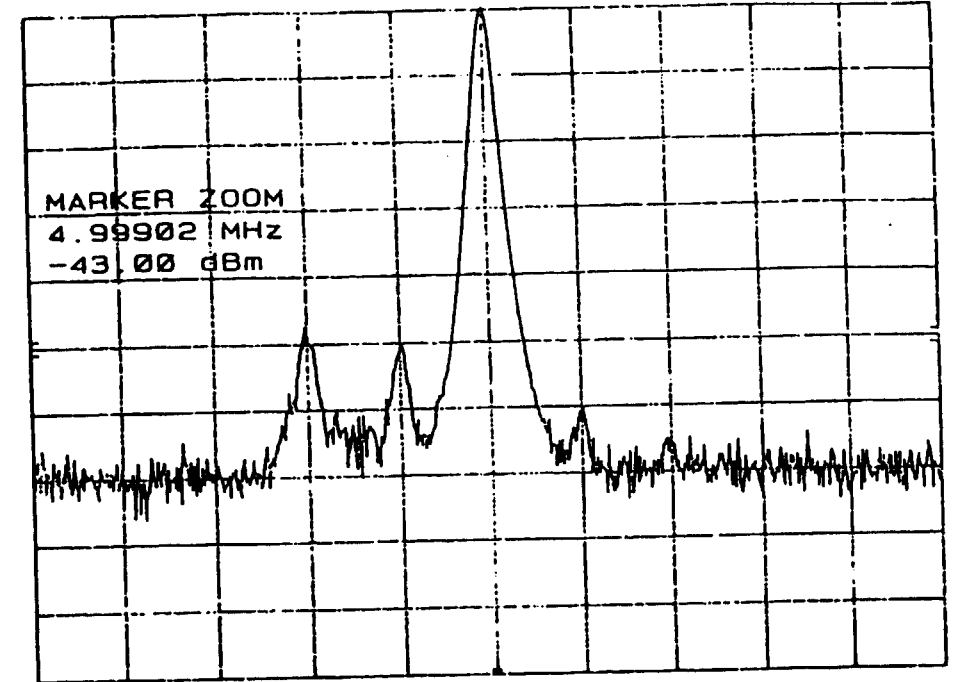

FIGURE E

RESOLUTION BANDWIDTH 100 HZ  
 SCAN WIDTH 10 KHZ  
 INPUT ATTEN. 10 DB  
 SCAN TIME 3.0 SEC  
 RANGE PER DIVISION  
 VIDEO FILTER 3 KHZ  
 10 DB LOG  
 LOG REF +10  
 SCAN MODE SINGLE  
 CENTER FREQUENCY 74.99908 MHZ  
 LINEAR SENSITIVITY AS REQ'D  
 SCAN TRIGGER AUTO  
 STORAGE STANDARD  
 INTENSITY AS REQ'D  
 PERSISTENCE MAXIMUM

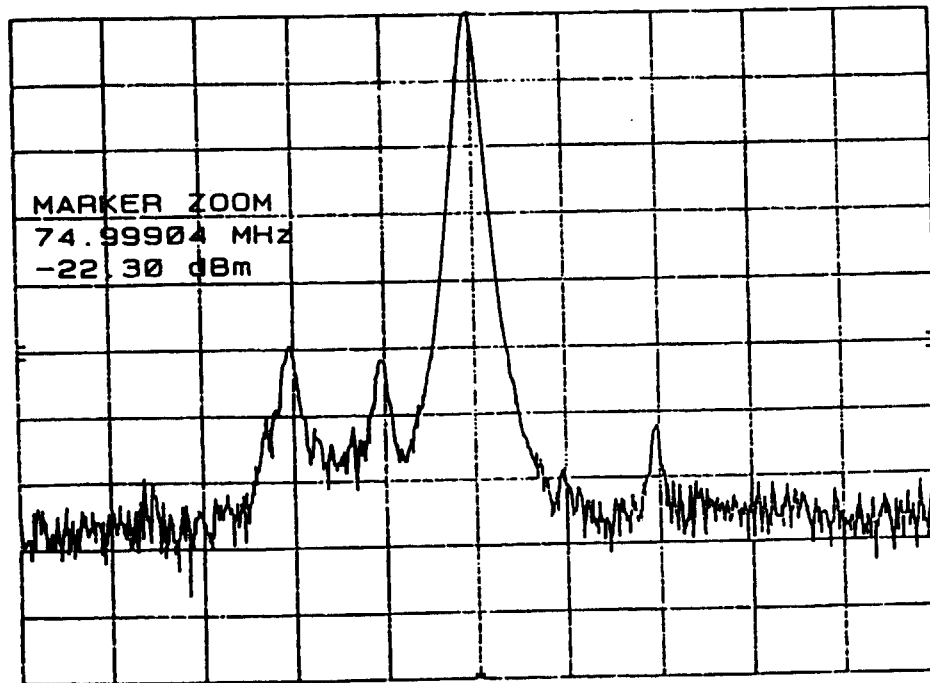

FIGURE D

RESOLUTION BANDWIDTH 100 HZ  
 SCAN WIDTH 10 KHZ  
 INPUT ATTEN. 10 DB  
 SCAN TIME 3.0 SEC  
 RANGE PER DIVISION  
 VIDEO FILTER 3 KHZ  
 10 DB LOG  
 LOG REF +10  
 SCAN MODE SINGLE  
 CENTER FREQUENCY 4.99902 MHZ  
 LINEAR SENSITIVITY AS REQ'D  
 SCAN TRIGGER AUTO  
 STORAGE STANDARD  
 INTENSITY AS REQ'D  
 PERSISTENCE MAXIMUM

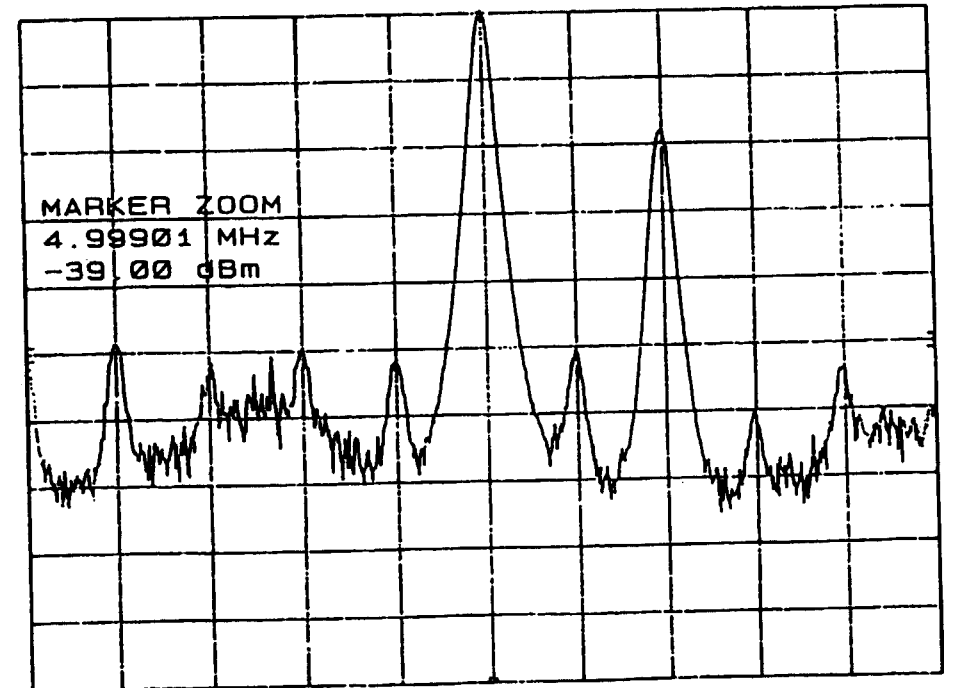

FIGURE F

**MODULATOR/DEMODULATOR FAULT ISOLATION ALIGNMENT PROCEDURE (1 of 2)**

The alignment procedure is to be used in either of these situations (1) the performance test calls a potentiometer out of adjustment, or (2) one of the following is replaced:

1. First frequency converter, A1A1A1.
2. Second frequency converter, A1A1A2.
3. Third frequency converter, A1A1A3.
4. Audio control hybrid, HY1.

The procedure consists of special tools and test equipment, alignment setup, preliminary setup, and alignment procedures.

**SPECIAL TOOLS AND TEST EQUIPMENT**

The special tools and test equipment required for the alignment procedure are the same as those listed in the table on page 6-8.

**ALIGNMENT SETUP**

The alignment setup is the same as the setup shown on page 6-9.

**PRELIMINARY SETUP**

1. Remove the modulator/demodulator from the RT and connect the module as on page 6-9.
2. Set rf signal generator at J2 to 104.999 MHz, +3 dbm with tolerance +2, -1 dbm.
3. Use the following inputs for J1 and J4:  
J1: 70 MHz -4 dbm  $\pm 1$  dbm  
J4: 5 MHz, 0 dbm +1, -2 dbm
4. Adjust audio generator and attenuator to obtain 0.6 mV rms, 1 -kHz signal at the output of the attenuator.
5. Shunt across 150-ohm resistor to ground and connect to audio input keying adapter as shown on page 6-9.
6. Select VTR and PTT test box switches.

**TRANSMIT OUTPUT LEVEL ALIGNMENT, R3, R6, R10, AND R14**

1. Adjust ALC offset, R6, on modulator/demodulator for maximum CCW. Connect a 0-6 V dc source to the test box ALC terminals and adjust to 0.0 +0.05 V dc.
2. Adjust R10 to obtain 80 mV rms at TP13. If output power is within 1 db of 28 dbm, readjust R10 until the output power is 28.0 +0.25 dbm. If output power is not within 1 dbm of 28 dbm, adjust the fixed pad, R20, R21, and R22, to the nearest value that produces 28.0  $\pm 1.0$  dbm with 80 mV rms of drive at TP13. The fixed pad values are given in the table on page 6-18. Once the fixed pad is adjusted, adjust R10 until the output power is 28.0  $\pm 0.25$  dbm and verify that the drive level at TP13 is 80  $\pm 10$  mV rms.
3. Apply a 1 -kHz, 0-dbm input to modem tone test point J5-9. Place voice-operated gain adjustment device (vogad) bypass switch in bypass position (grounding J5-1). Adjust R32 to obtain 28.0  $\pm 0.2$  dbm at the modulator/demodulator output (J3).
4. Remove audio input to test box and open the PIT switch.
5. Adjust cw level R3, to obtain 28.0 dbm with tolerance  $\pm 0.2$  dbm output from the modulator/demodulator.
6. Adjust sidetone, R14, to obtain 500  $\pm 10$  mV rms, 1 -kHz output.

**ALC RELEASE TIME ALIGNMENT, R6**

1. Connect a 0-6 V dc source to the test box ALC input terminals, and adjust to 0.8  $\pm 0.01$  V dc.
2. Adjust ALC adjust, R6, to obtain an output power of +22.0 dbm  $\pm 0.25$  db.
3. Increase ALC voltage to 6 V dc. Ground ALC input voltage and adjust R9 for a release time constant of 750  $\pm 100$  msec.
4. Open cw key, TX enable, and sidetone switches.

**RECEIVE LEVEL ALIGNMENT**

1. Set lefthand MODE pushbutton to V RCV and righthand MODE pushbutton to USB.
2. Adjust input generator for 16.001 MHz, -103 dbm input to J3 of the modulator/demodulator.
3. Use the following inputs for J1, J2, and J4.  
J1: 70 MHz, -4 dbm  $\pm 1$  dbm  
J2: 91 MHz +3 dbm +2, -1 dbm  
J4: 5MHz, 0dbm +1, -2 dbm
4. Adjust receive level control, R37, to obtain 2.0  $\pm 0.1$  V dc AGC voltage at TP18 with the case of the second converter AGC FET (Q3) shorted to ground.

**MODULATOR/DEMODULATOR FAULT ISOLATION ALIGNMENT PROCEDURE (2 of 2)**

**DATA MODE AUDIO OUTPUT ALIGNMENT, R11**

1. Set lefthand MODE pushbutton to D RCV.
2. Adjust the Input at J3 to -92 dbm.
3. Adjust data adjust, R11, to obtain 0.78 ±0.04 V rms audio output into a 500-ohm load.

**LOW VOLTAGE ALARM ALIGNMENT, R19**

1. Close TX enable (TX EN) and PIT test box switches.  
 TX EN - +28 V  
 PTT - ground  
 Fault - ground
2. Reduce the 26.0 V dc Input voltage to 19.0 V dc.
3. Adjust low voltage threshold adjust, R19, to the point where an audible clicking sound is heard in the handset.
4. Open TX enable and PTT.

**DISCONNECT THE TEST EQUIPMENT**

**SELECTED RESISTORS FOR MODULATOR/DEMODULATOR R20, R21, AND R22**

Transmit fixed 50-ohm pad adjustment. Refer to modulator/demodulator A1A1 alignment. (Before replacing R20, R21, and R22, examine these resistors on the modulator/demodulator and record individual values for references.)

Pad Attenuation (db)	Resistor Values (Ohms)		
	R20	R21	R22
3	300	18	300
4	220	24	220
5	180	30	180
6	150	36	150
7	130	43	130
8	110	51	110
9	110	62	110
10	91	68	91
11	91	82	91
12	82	91	82
13	82	110	82

Ohms	Military No.
18	RLR05C18R0GM
24	RLR05C24R0GM
30	RLR05C30R0GM
36	RLR05C36R0GM
43	RLR05C43R0GM
51	RLR05C51
62	RLR05C62R0GM
68	RLR05C68R0GM
82	RLR05C82R0GM
91	RLR05C91R0GM
110	RLR05C1100GM
130	RLR05C1300GM
150	RLR05C1500GM
180	RLR05C1800GM
220	RLR05C2200GM
300	RLR05C3000GM

**FIRST FREQUENCY CONVERTER FAULT ISOLATION**

The first frequency converter fault isolation procedure is divided into the following: special tools and test equipment, performance test setup, and performance test.

**I FIRST FREQUENCY CONVERTER FAULT ISOLATION SPECIAL TOOLS AND TEST EQUIPMENT I**

Description	Part Number
RF Coax Cable (2 each)	...
RF Extender Cable (3 each)	...
Audio Input/Keying Adapter	...
Modulator/Demodulator Test Extender Cable	...
Frequency Converter Test Bed	...
Tool Kit, Electronic	TK-105/G
Bench Repair Center	Pace PRC-350C
Maintenance Kit, Printed Circuit	MK-984/A
Radio Set, Test Bed	AN/PRC-104
Signal Generator, RF	
Digital Multimeter (DVM, ohmmeter function)	
Spectrum Analyzer	
— High Resolution IF. Section	
— RF Section	
— Tracking Generator	
— High Impedance Probe	
Power Supply, DC	
Attenuator, Coaxial 20 db, 30 W min, 50 ohms	Narda 765-20

NOTE

Refer to page 1-6 for test equipment characteristics.

**FIRST FREQUENCY CONVERTER FAULT ISOLATION PERFORMANCE TEST SETUP**

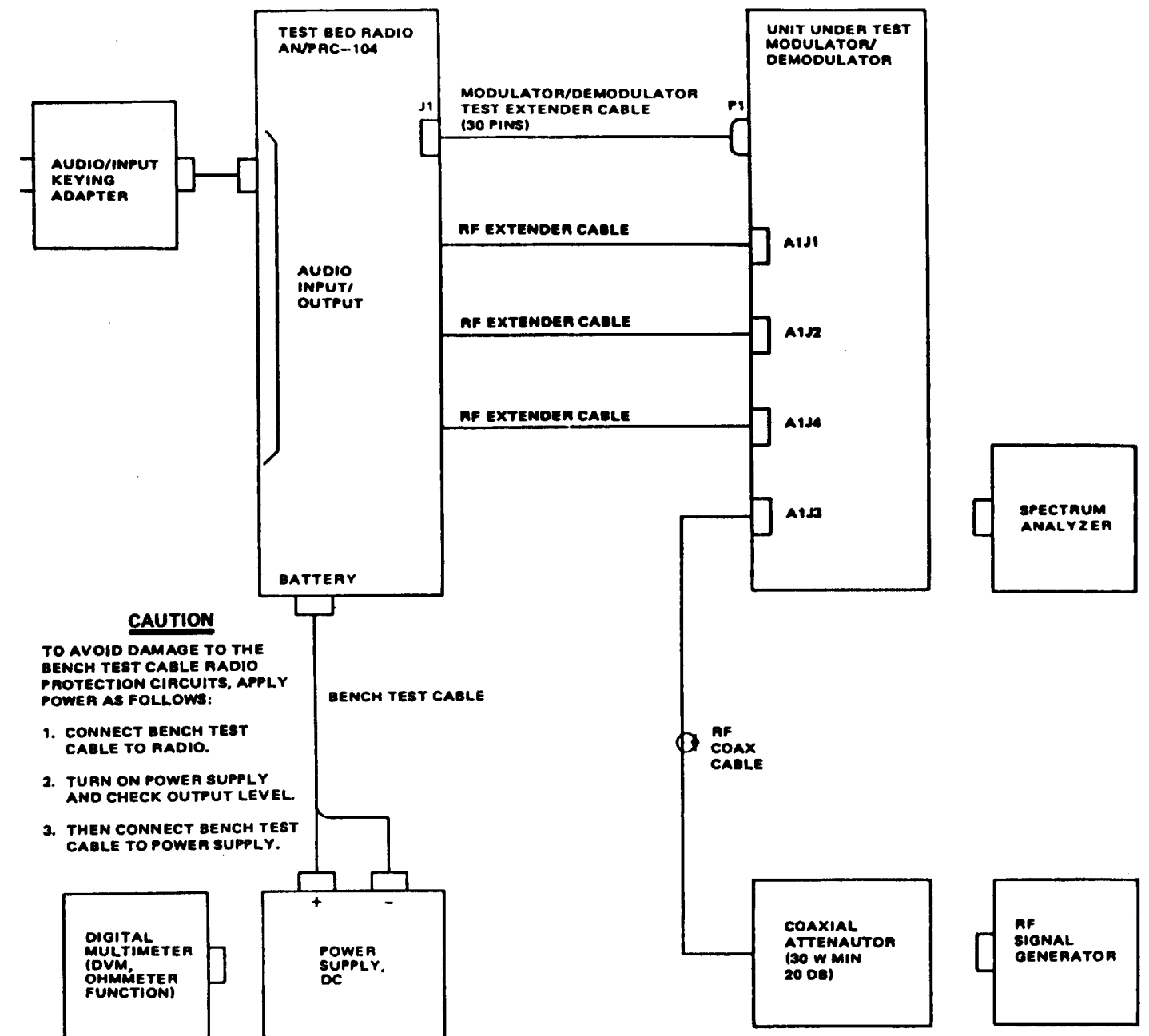

NOTES:

1. EQUIVALENT TEST EQUIPMENT MAY BE USED.
2. USE ONLY TEST EQUIPMENT THAT IS PROPERLY CALIBRATED. FAILURE TO DO SO MAY PROVIDE ERRONEOUS OR MISLEADING PERFORMANCE OR FAULT INDICATIONS.
3. BEFORE USING SPECTRUM ANALYZER, RF SECTION HP-8553B, PERFORM PRELIMINARY CHECKS CONTAINED IN THE HP-8553B OPERATING MANUAL.

Figure 6-3 First Frequency Converter Fault Isolation Performance Test Setup

**FIRST FREQUENCY CONVERTER FAULT ISOLATION PERFORMANCE TEST**

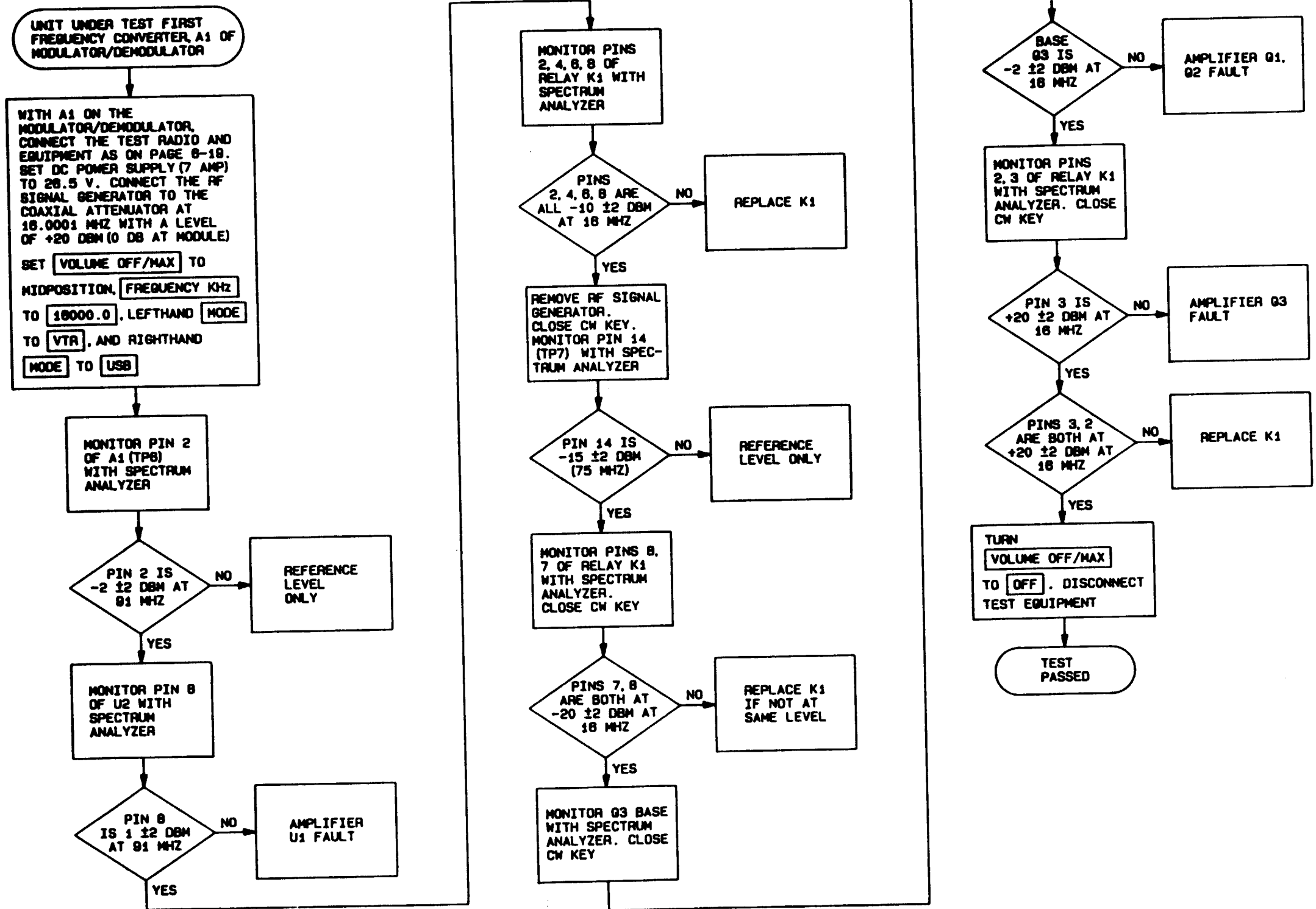

**SECOND FREQUENCY CONVERTER FAULT ISOLATION**

The second frequency converter fault isolation procedure is divided into the following: special tools and test equipment, performance test setup, and performance test.

**SECOND FREQUENCY CONVERTER FAULT ISOLATION SPECIAL TOOLS AND TEST EQUIPMENT**

The special tools and test equipment required for the second frequency converter fault isolation procedure are the same as those listed on page 6-19 for the first frequency converter.

**SECOND FREQUENCY CONVERTER FAULT ISOLATION PERFORMANCE TEST SETUP**

The performance test setup for the second frequency converter fault isolation procedure is the same as the setup shown on page 6-19 for the first frequency converter.

**SECOND FREQUENCY CONVERTER FAULT ISOLATION PERFORMANCE TEST**

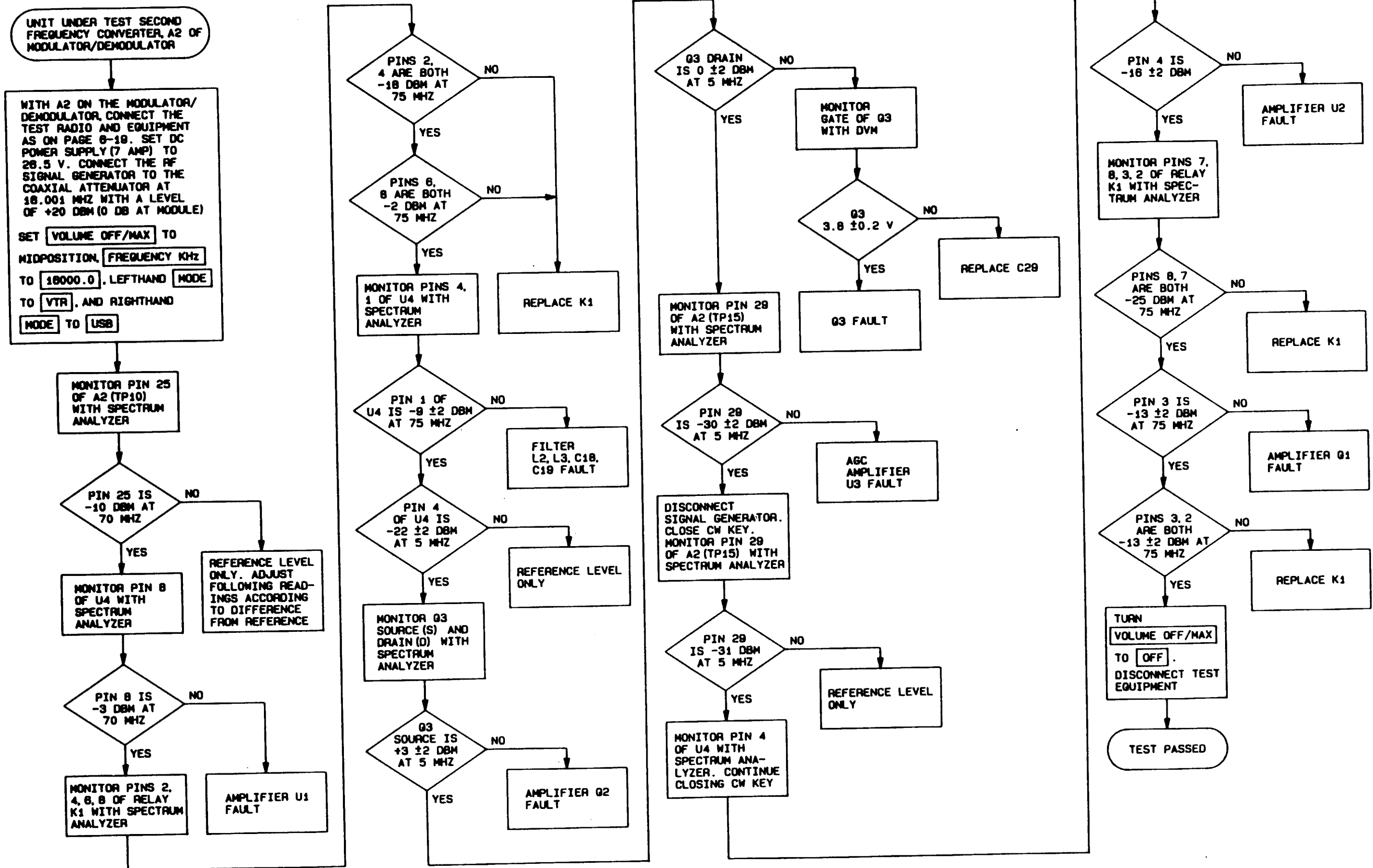



**THIRD FREQUENCY CONVERTER FAULT ISOLATION**

The third frequency converter fault isolation procedure is divided into the following: special tools and test equipment, performance test setup, and performance test.

**THIRD FREQUENCY CONVERTER FAULT ISOLATION SPECIAL TOOLS AND TEST EQUIPMENT**

The special tools and test equipment required for the third frequency converter fault isolation procedure are the same as those listed on page 6-19 for the first frequency converter.

**THIRD FREQUENCY CONVERTER FAULT ISOLATION PERFORMANCE TEST SETUP**

The performance test setup for the third frequency converter fault Isolation procedure is the same as the setup shown on page 6-19 for the first frequency converter.

**THIRD FREQUENCY CONVERTER FAULT ISOLATION PERFORMANCE TEST**

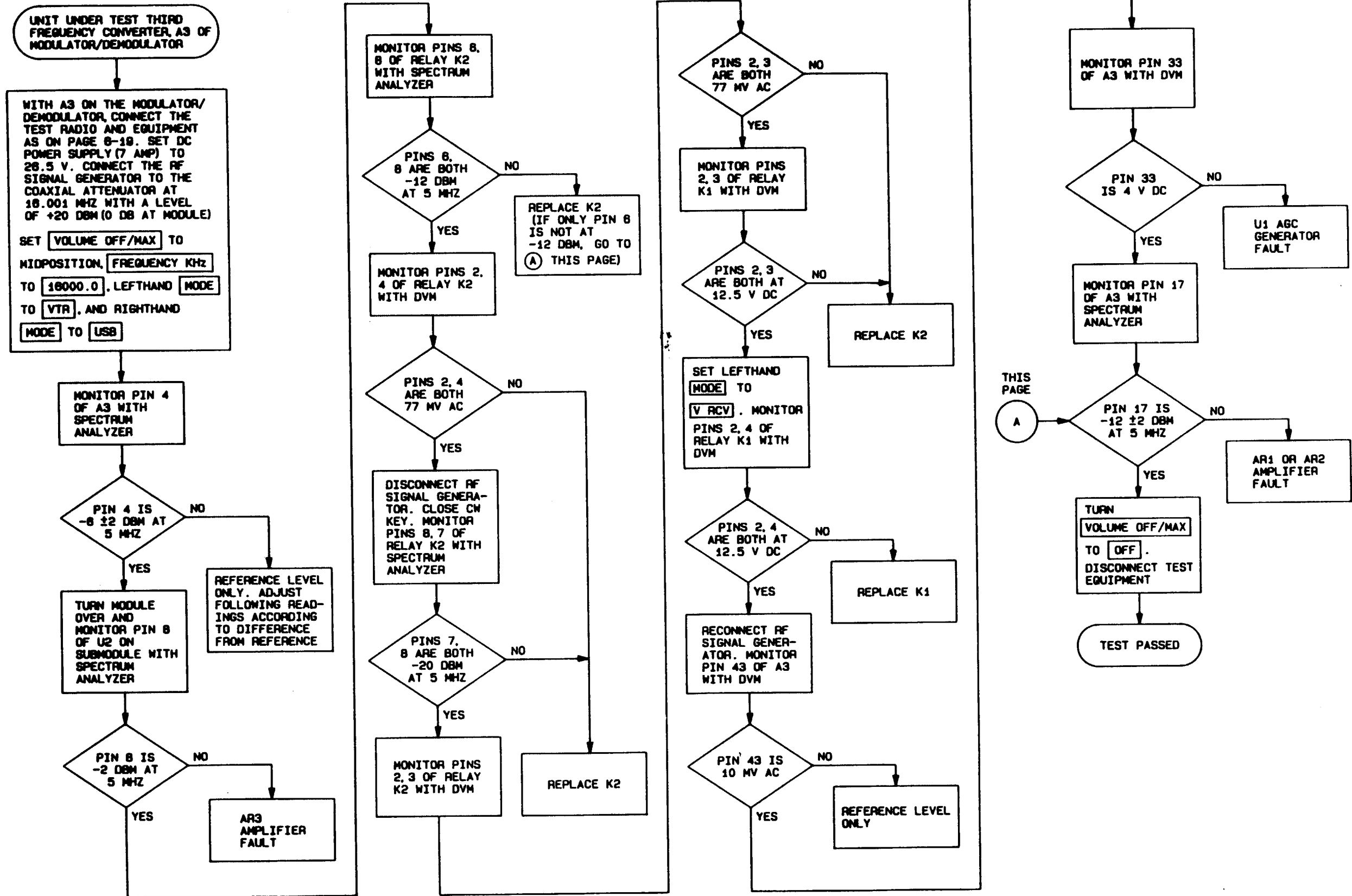

**SYNTHESIZER FAULT ISOLATION**

The synthesizer fault isolation procedure is divided into the following: special tools and test equipment, performance test setup, performance test, and alignment procedure.

**SYNTHESIZER FAULT ISOLATION SPECIAL TOOLS AND TEST EQUIPMENT**

Description	Part Number
Synthesizer Test Extender Cable (36-pin)	...
Tool Kit, Electronic	TK-105/G
Bench Repair Center	Pace PRC-350
Maintenance Kit, Printed Circuit	MK-984/A
Radio Set, Test Bed	AN/PRC-104
Frequency Counter	
RF Power Meter	
RF Spectrum Analyzer	
Oscilloscope	
Power Supply	

**NOTE**

Refer to page 1-6 for test equipment characteristics.

**SYNTHESIZER FAULT ISOLATION PERFORMANCE TEST SETUP**

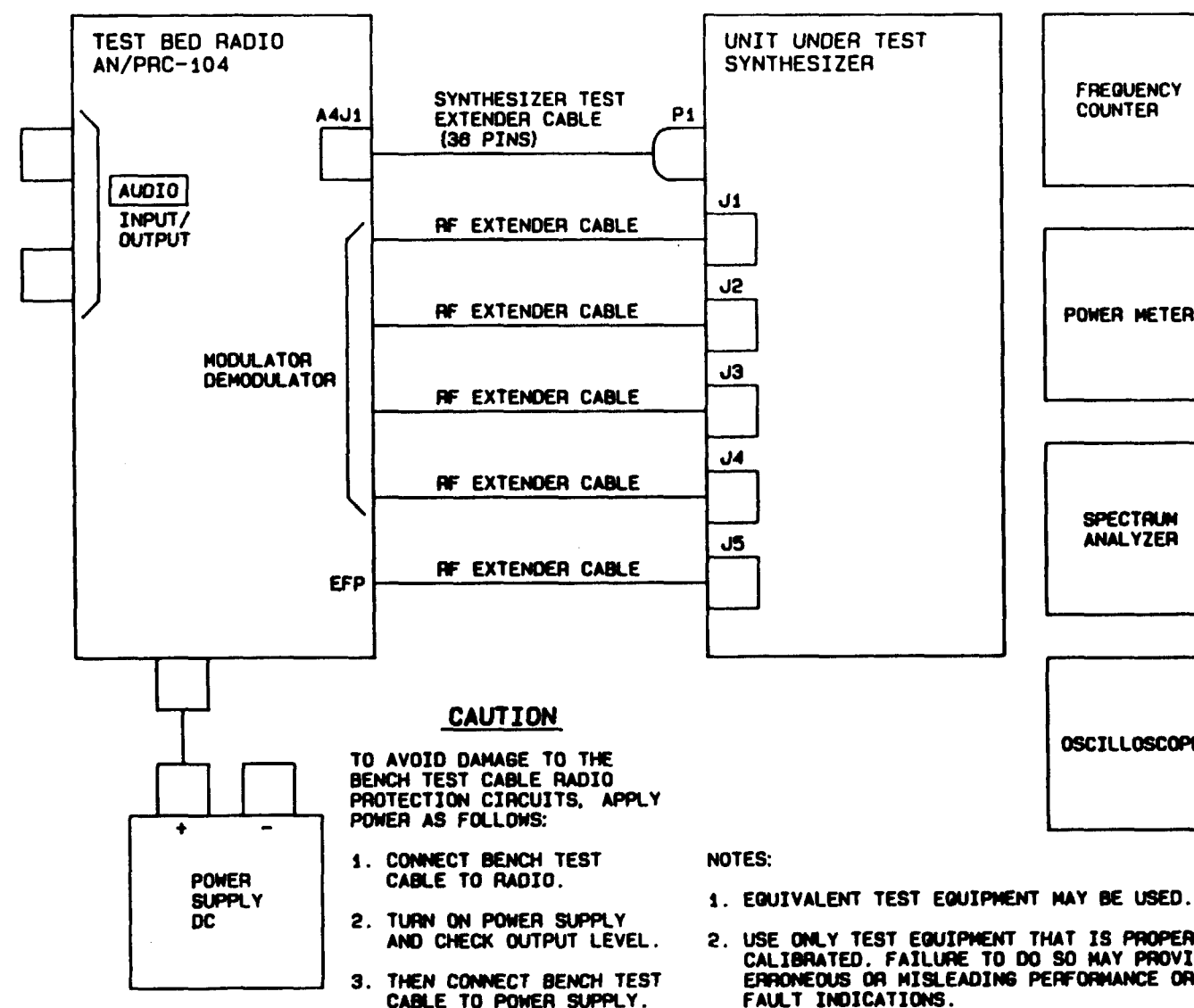
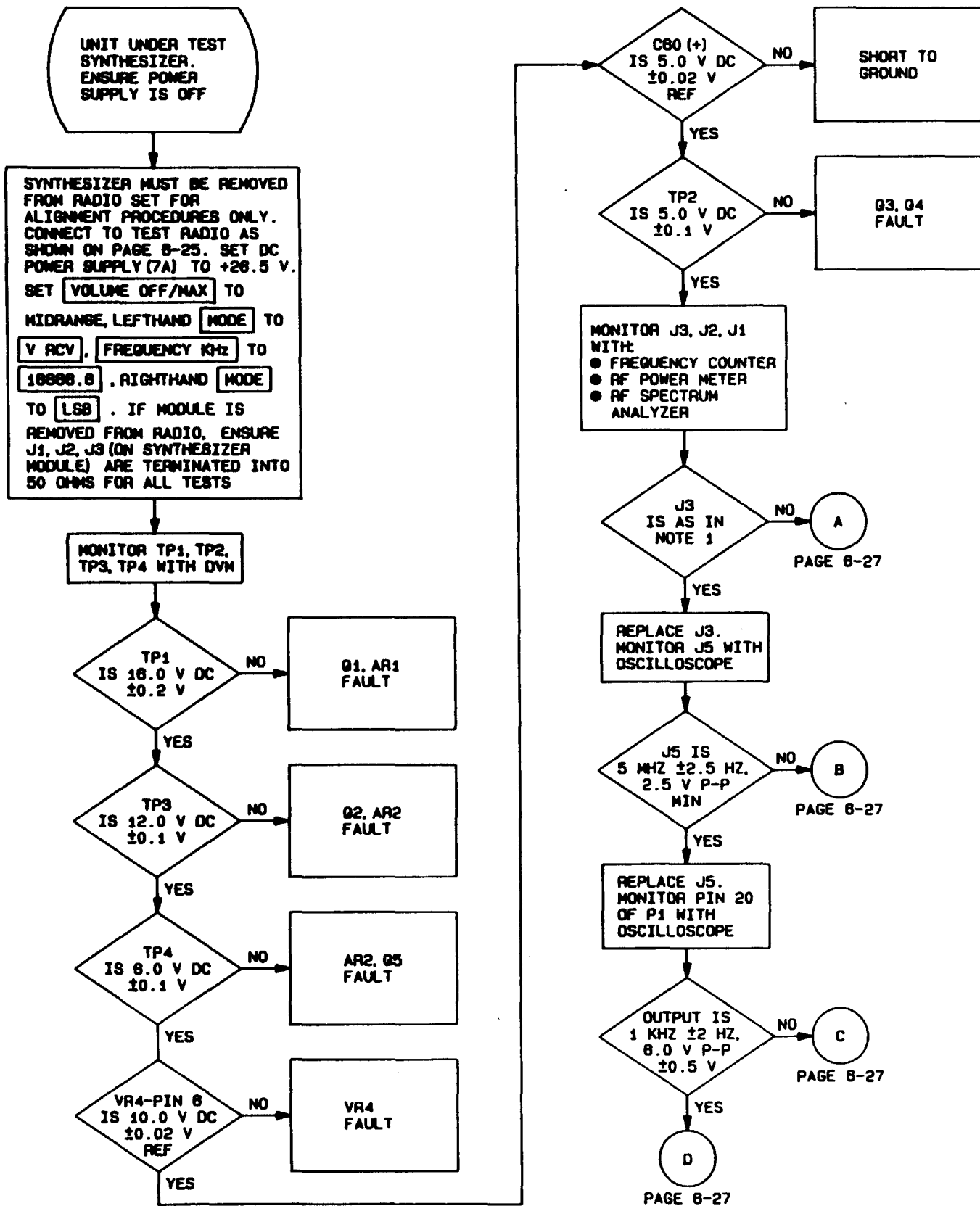

Figure 8-4. Synthesizer Fault Isolation Performance Test Setup

**SYNTHESIZER FAULT ISOLATION PERFORMANCE TEST (1 of 4)**



NOTES:

1. 3RD LO OUTPUT REQUIREMENTS (J3)

FREQUENCY: 5 MHz ±2.5 Hz (±5.0 Hz IF RIBIDIUM FREQUENCY STANDARD NOT USED)  
POWER: 0 DBM ±2 DB

2. 2ND LO OUTPUT REQUIREMENTS (J2)

FREQUENCY: 70 MHz ±70 Hz (USB)  
80 MHz ±80 Hz (LSB)  
POWER: -4 DBM ±1 DB  
SPURIOUS: ±150 KHz OF  $f_0$  40 MHz TO 90 MHz\*  
85 DBC 55 DBC

\* EXCLUDE SPURIOUS SIGNALS WITHIN ±150 KHz OF  $f_0$

3. 1ST LO OUTPUT REQUIREMENTS (J1)

FRONT PANEL FREQUENCY SETTING (KHz)	FREQUENCY ( $f_0$ ), J1	RF POWER, J1
02000.0	77,000.0 KHz ±77 Hz	3 DBM +2, -1 DB
18888.8	91,888.8 KHz ±92 Hz	3 DBM +2, -1 DB
28888.8	104,888.8 KHz ±105 Hz	3 DBM +2, -1 DB

BCD INPUT LOGIC FREQUENCY CONTROL VERSUS INPUT  
"0"=-1.5 V MAXIMUM, "1"=-3.5 V MINIMUM

$(f_0)$	U8 BCD FREQUENCY WORD																					
	7	8	14	17	19	21	23	24	25	26	27	28	29	30	31	32	33	34	35	37	38	39
77,000.0 KHz ±77 Hz	0	0	0	0	1	0	0	0	0	0	0	0	0	0	0	0	0	0	0	0	0	0
91,888.8 MHz ±92 Hz	0	1	0	1	1	0	0	1	1	0	0	1	1	0	0	1	1	0	0	1	1	0
104,888.8 MHz ±105 Hz	1	0	1	0	0	1	1	0	0	1	1	0	0	1	1	0	0	1	1	0	0	1

SPURIOUS			
±3 KHz OF $f_0$	±3 KHz TO 10 KHz OF $f_0$	±10 KHz TO ±50 KHz OF $f_0$	±50 KHz TO ±5 MHz OF $f_0$
35 DBC MAX	LINEAR DECREASE FROM 35 DBC TO 60 DBC	60 DBC MAX	70 DBC MAX

4. CURRENT SWITCH WAVEFORMS

TEST FREQUENCY (KHz)	MONITOR A1, PIN:	WAVEFORM
18800.1	21	
18801.0	19	
18810.0	20	

5. WHEN MAKING CONTINUITY CHECKS, ENSURE EQUIPMENT IS DE-ENERGIZED

**SYNTHESIZER FAULT ISOLATION PERFORMANCE TEST (2 of 4)**

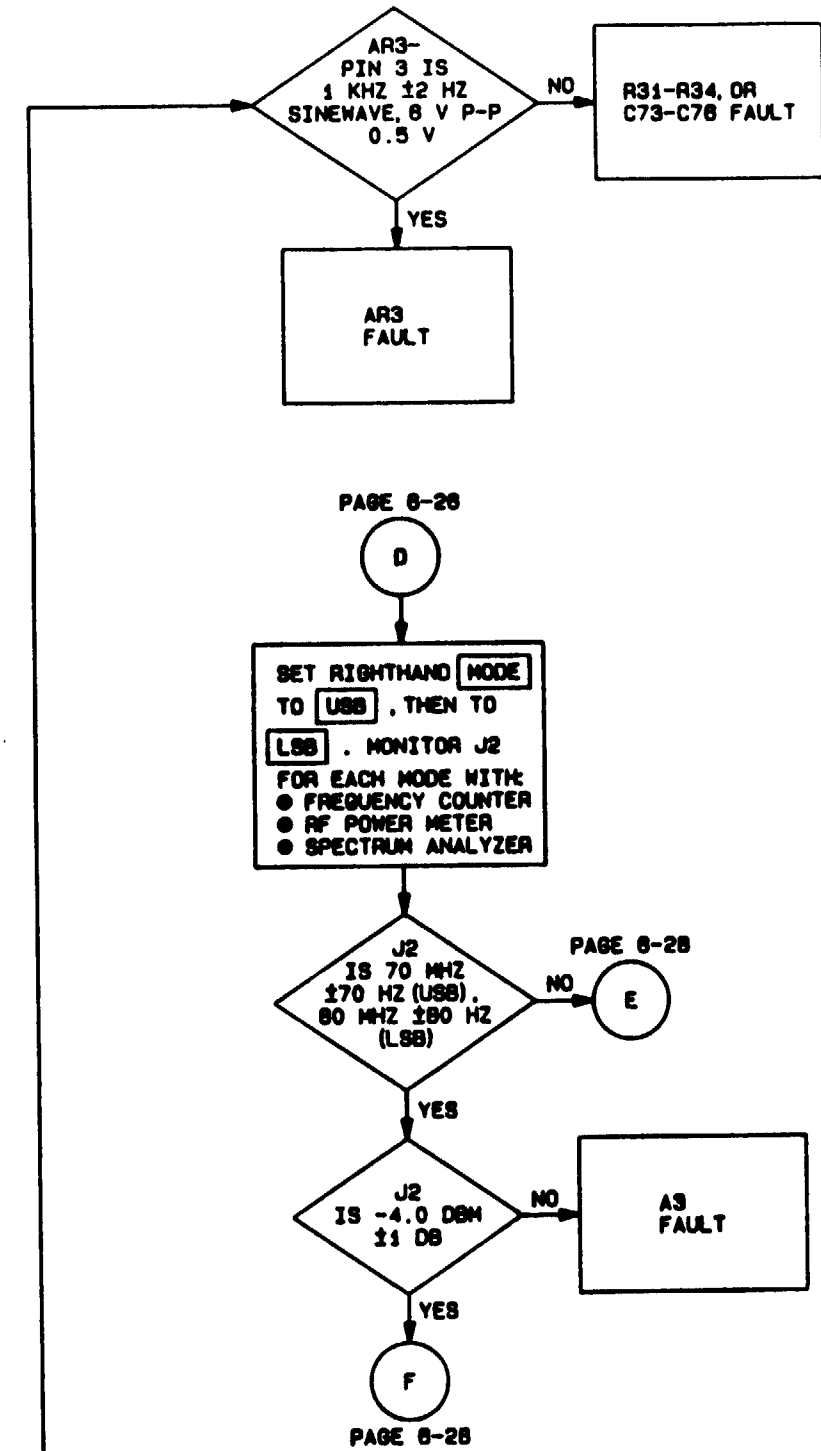
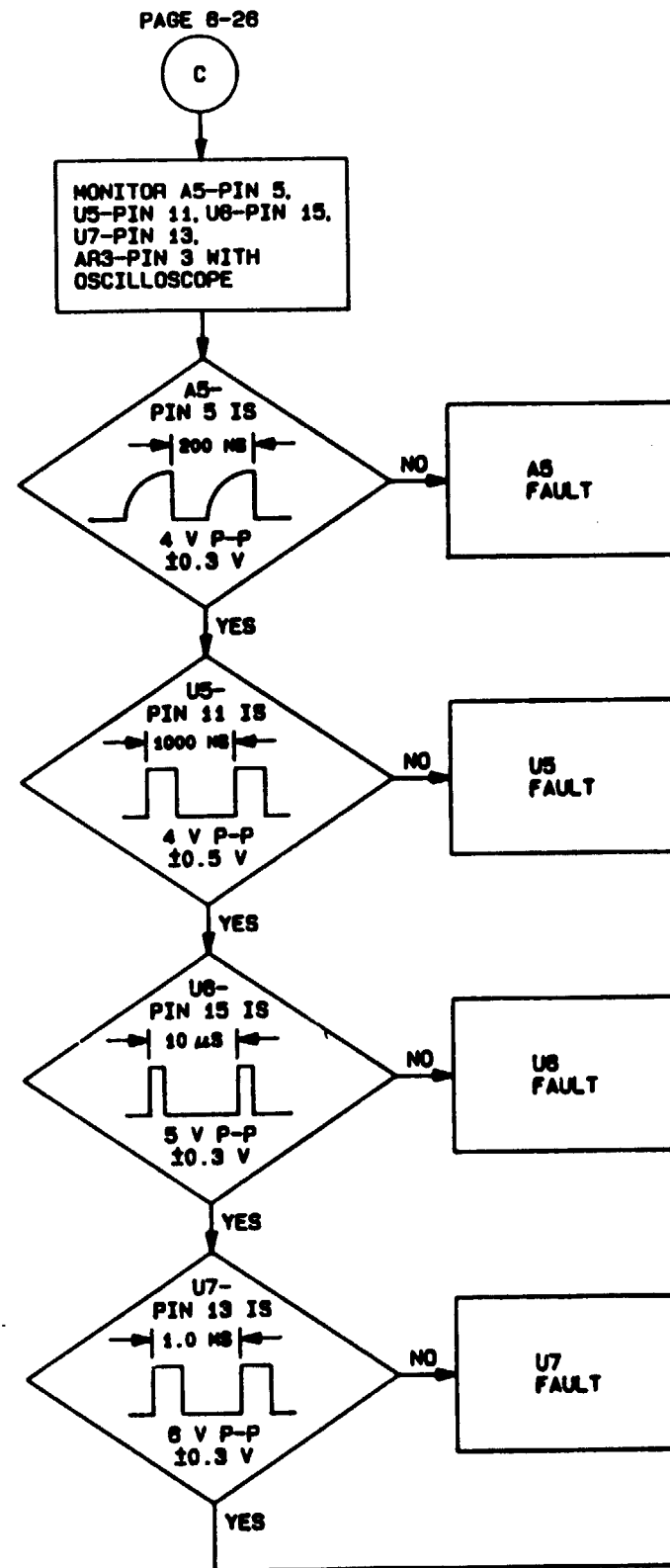
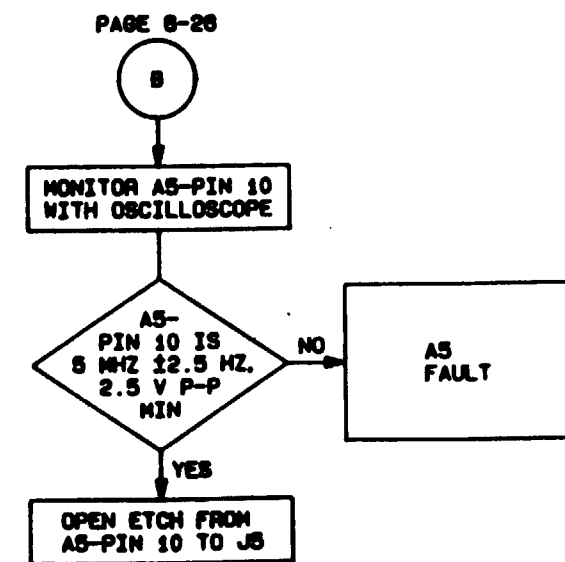
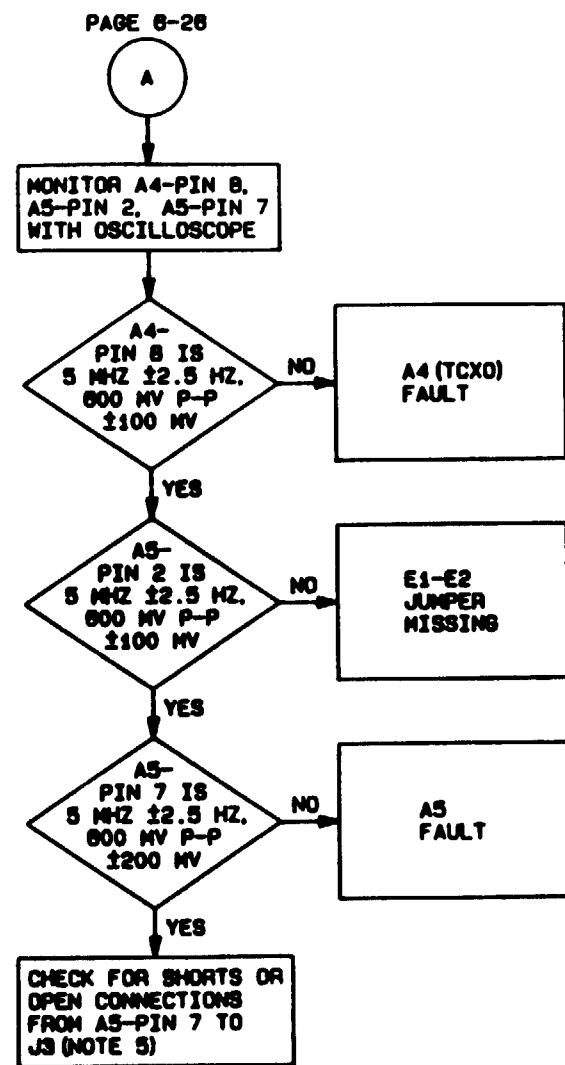

**SYNTHESIZER FAULT ISOLATION PERFORMANCE TEST (3 of 4)**

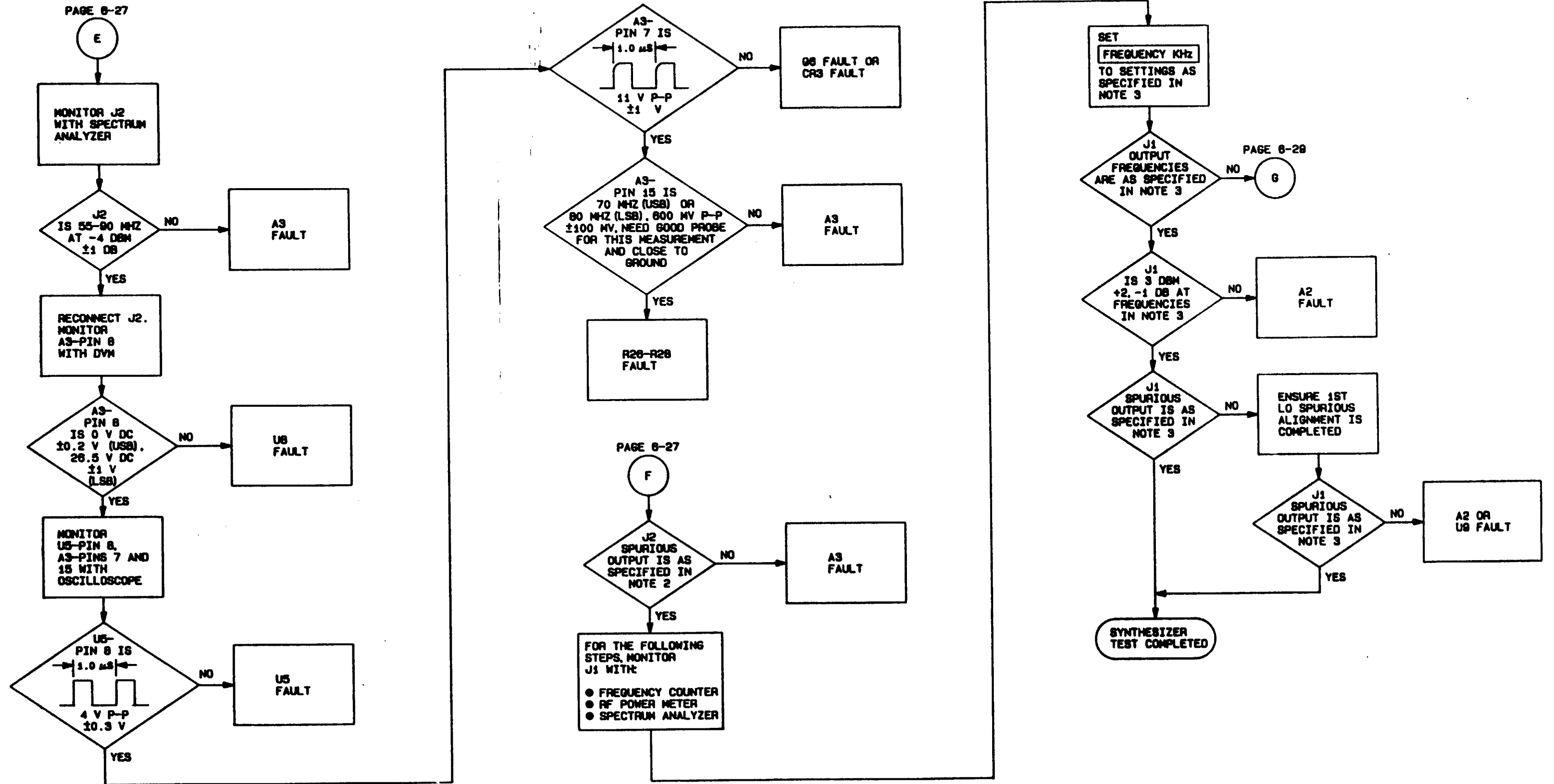

**SYNTHESIZER FAULT ISOLATION PERFORMANCE TEST (4 of 4)**

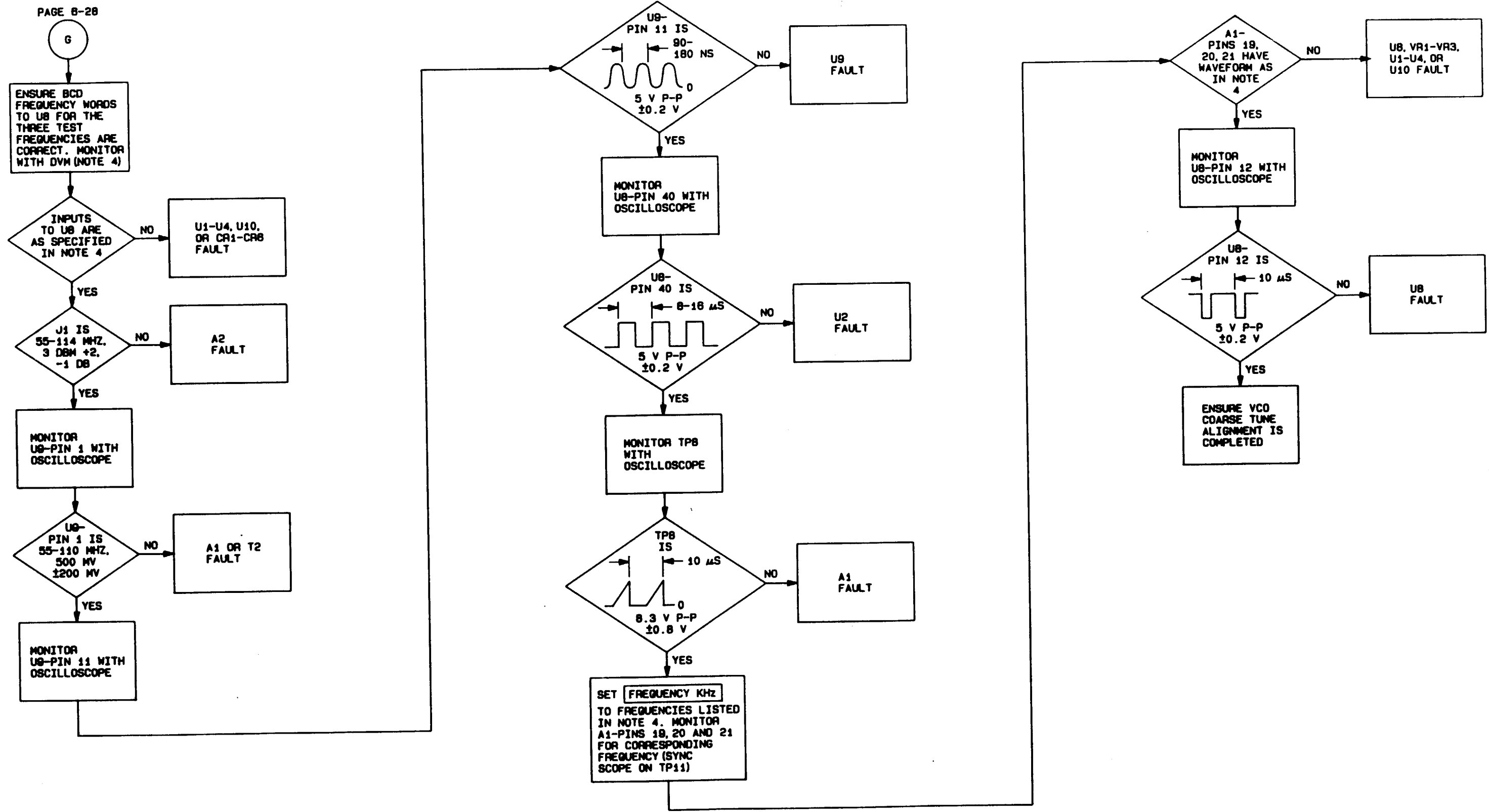

## SYNTHESIZER FAULT ISOLATION ALIGNMENT PROCEDURE

The alignment procedure is to be used in either of these situations (1) the fault isolation test calls for a specific alignment procedure, or (2) one of the following is replaced:

1. Ramp generator, A1A3A1.
2. 77-105 MHz VCO, A1A3A2.
3. 70/60 MHz VCO, A1A3A3.
4. 5 MHz TCXO, A1A3A4.
5. 5 MHz buffer/driver, A1A3A5.

If one or more of the five submodules listed above are replaced, then both alignments outlined on this page must be performed.

The procedure consists of special tools and test equipment, alignment setup, and alignment procedures.

### SPECIAL TOOLS AND TEST EQUIPMENT

The special tools and test equipment required for the alignment are the same as those listed in the table on page 6-25.

### ALIGNMENT SETUP

The alignment setup is the same as the setup shown on page 6-25.

### PRELIMINARY SETUP

1. Connect the test radio as on page 6-25. Comply with notes 1 and 2 on page 6-25.
2. Set dc power supply to +26.5 V  $\pm$  0.1 V. Power supply should be capable of putting out 5 A.
3. Set the test radio controls on the control panel and amplifier/coupler as follows:
  - a. Lefthand MODE to V-RCV
  - b. ANT SEL to 50 OHMS (bypass)
  - c. VOLUME OFF/MAX to midposition

### 1ST LO SPURIOUS ALIGNMENT

1. Set FREQUENCY KHz to 15001.0.
2. Monitor the 1st LO output, J1, of the module with a spectrum analyzer
3. Adjust ramp generator, submodule 10 kHz phase adjust, R8, for minimum 1 kHz spur levels within  $\pm$ 5 kHz of 90.001 MHz.
4. 1 kHz spurious shall be 35 dbc or better.
5. Set FREQUENCY KHz to 15010.0.
6. Adjust ramp generator submodule 1 kHz phase adjust, R9, for minimum 1 kHz spur levels within  $\pm$ 5 kHz of 90.001 MHz.
7. 1 kHz spurious shall be 35 dbc or better.

### VCO COARSE TUNE ALIGNMENT

1. Set FREQUENCY KHz to 2900.0.
2. Monitor TP5 with a digital voltmeter and connect a spectrum analyzer to J1.
3. Verify synthesizer output at J1 is phase-locked at 77.900 MHz on the spectrum analyzer.
4. Measure the voltage at TP5 and adjust offset, R1 9, for 6.0  $\pm$ 0.5 V.
5. Record the voltage at TP5 and the output frequency at J1.  
 $V_a = \text{_____ V}$        $F_a = \text{_____ MHz}$
6. Set FREQUENCY KHz to 2990.0.
7. Verify synthesizer output at J1 is phase-locked at 104.900 MHz on the spectrum analyzer. If not phase-locked decrement the output frequency in 100 kHz steps until phase-lock is acquired.
8. Record the voltage at TP5 and the output frequency at J1.  
 $V_b = \text{_____ V}$        $F_b = \text{_____ MHz}$
9. Adjust gain, R25, for  
 $V_a + 0.5 (V_b - V_a) = V_{at TP5}$
10. Repeat steps 6 thru 9 until  $F_a = 2.900$  MHz and  $F_b = 29.900$  MHz and the absolute difference between  $V_a$  and  $V_b$  is less than 0.1 V.  
 $V_a - V_b < 0.1$  V Yes, continue.  
 No, go to step 6.  
 If this is unsuccessful, set R19 and R25 to their midrange settings and begin again at step 1.
11. Increase the frequency from 2000.00 kHz to 29900.0 kHz in 100-kHz steps and record the minimum and maximum voltages at TP5 and the frequencies at which the minimum and maximum voltages were found.  
 $V_{max} = \text{_____ V}$        $F_{max} = \text{_____ MHz}$   
 $V_{min} = \text{_____ V}$        $F_{min} = \text{_____ MHz}$
12. Calculate the desired voltage at  $F_{max}$  by the equation:  
 $V_{max}(\text{desired}) = 6.00 + 0.5 (V_{max} - V_{min})$ .  $V_{max}(\text{desired}) = \text{_____}$
13. Adjust R19 to this voltage with frequency equal to  $F_{max}$
14. Record  $V_a = \text{_____ V}$  at  $F_a = 2.900$  MHz;  $V_b = \text{_____ V}$  at  $F_b = 29.900$  MHz. Verify that  $V_a - V_b < 0.1$  V. If not, begin again at step 9.
15. Verify that  $V_{max} < 7.0$  V at  $F_{max}$  and that  $V_{min} > 5.0$  V at  $F_{min}$ .  
 If this is not true and  $V_{max} - V_{min} < 2.0$  V, begin again at step 9.  
 If this is not true and  $V_{max} - V_{min} > 2.0$  V, the varactor on the 77-105 MHz VCO submodule assembly must be replaced (ie, this unit should not have passed submodule tests).



**HARMONIC FILTER FAULT ISOLATION**

The harmonic filter fault isolation procedure is divided into the following: special tools and test equipment, performance test setup, performance test, and alignment procedure.

**HARMONIC FILTER FAULT ISOLATION SPECIAL TOOLS AND TEST EQUIPMENT**

Description	Part Number
Harmonic Filter/Power Amplifier Test Extender Cable	...
RF Coax Cable (2 each)	...
Audio Input/Keying Adapter	...
Tool Kit, Electronic	TK-105/G
Bench Repair Center	Pace PRC-350C
Maintenance Kit, Printed Circuit	MK-984/A
Radio Set, Test Bed	AN/PRC-104
Digital Multimeter (DVM, ohmmeter function)	
Spectrum Analyzer	
— High Resolution IF. Section	
— RF Section	
— Tracking Generator	
Power Supply, DC	
Attenuator, Coaxial 20 db, 30 W min, 50 ohms	Narda 765-20

**NOTE**

Refer to page 1-6 for test equipment characteristics.

**HARMONIC FILTER FAULT ISOLATION PERFORMANCE TEST SETUP**

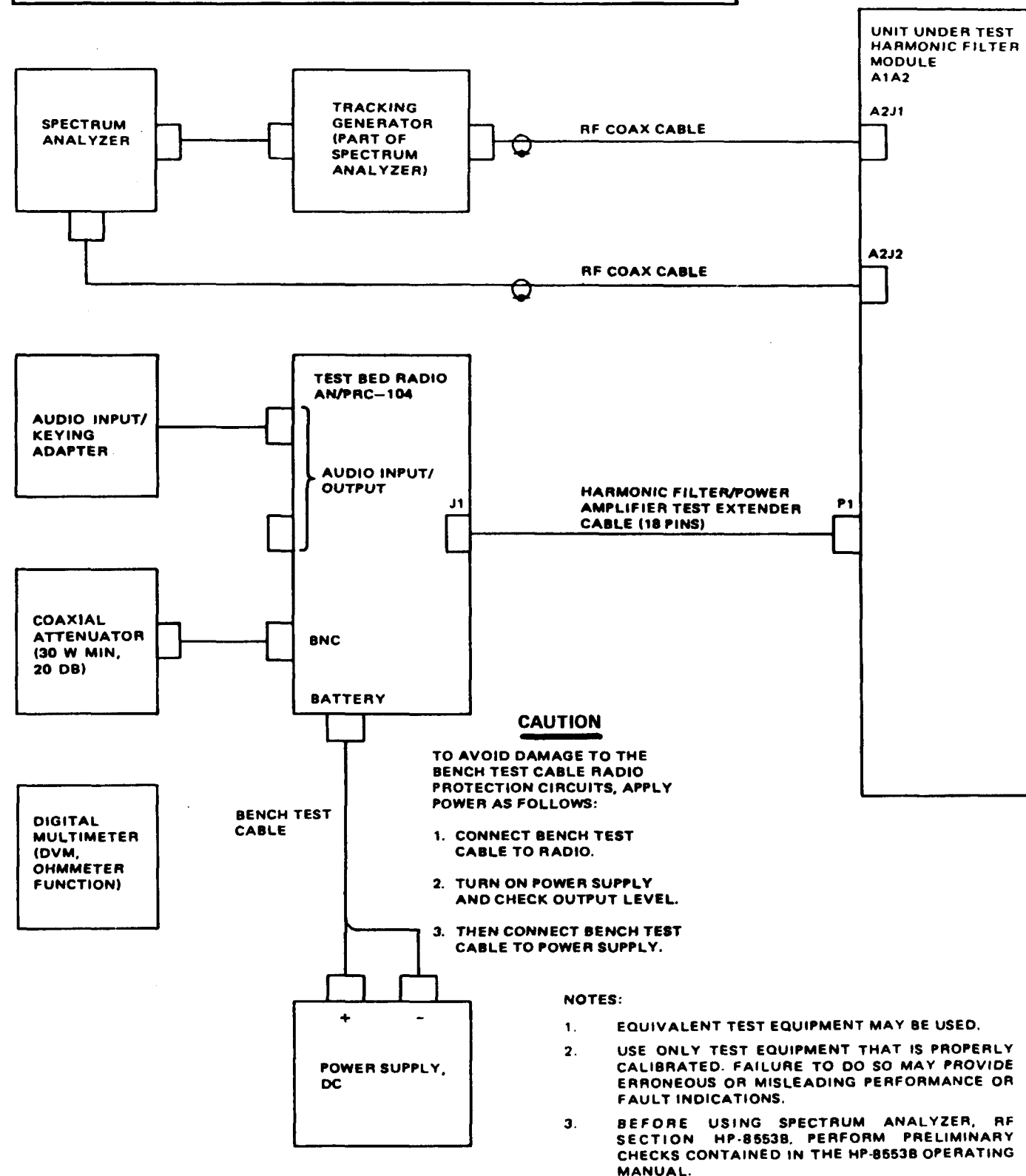

Figure 6-5. Harmonic Filter Fault Isolation Performance Test Setup

**HARMONIC FILTER FAULT ISOLATION PERFORMANCE TEST (1 of 4)**

**NOTES**

1. The narrowband criterion is a maximum of 1.8-db insertion loss in the passband. A shorting bar, connected between the two fabricated rf cables, should be used to achieve a 0-db reference. The wideband criterion is -40 db suppression beyond 3 times the lower band frequency of the selected filter. To obtain narrow and wideband spectral outputs as in the figures, set the controls on the spectrum analyzer as follows

<b>Controls</b>	<b>Narrow</b>	<b>Wide</b>
Scan Trigger — AUTO	AUTO	AUTO
Scan Mode — INT.	INT.	INT.
Video Filter — 10 kHz	OFF	10 kHz
Log/CM	2-db Log	10-db Log
Linear Sensitivity — 1	-1	-6
Log Reference — 0	0	10
Scan Time	5 ms	20 ms
Range	0-11 MHz	0-110 MHz
Input Attenuation	50 db	20 db
Bandwidth	100 kHz	300 kHz
Center Frequency	2.5 MHz	50 MHz
Scan Width	0.2 MHz (Per Division)	0.05 kHz (0-100 MHz) (Inner Red)
<b>Tracking Generator</b>		
Function	Track Analyzer	Same
RF Level	0 dbm	Same

Each filter can legitimately be checked by attaching the rf signal generator to A2J1 and the power meter to A2J2; the rf signal generator is set to upper, middle, and lower points on the passband, and the insertion loss (1.8 db maximum) is read on the power meter. A zero reference is established by connecting the rf signal generator to power meter.

- 2 Scan width is 0.5 MHz, center frequency is 4,000 kHz.
3. Scan width is 0.5 MHz, center frequency is 6,500 kHz.
4. Scan width is 1 MHz, center frequency is 10,000 kHz, range 0-110.
5. Scan width is 2 MHz, center frequency is 16,000 kHz, scan time 10 ms.
6. Scan width is 5 MHz, center frequency is 25,000 kHz, scan time 20 ms.
7. Unless otherwise specified, all voltage measurements taken with respect to chassis ground.

**HARMONIC FILTER FAULT ISOLATION PERFORMANCE TEST (2 of 4)**

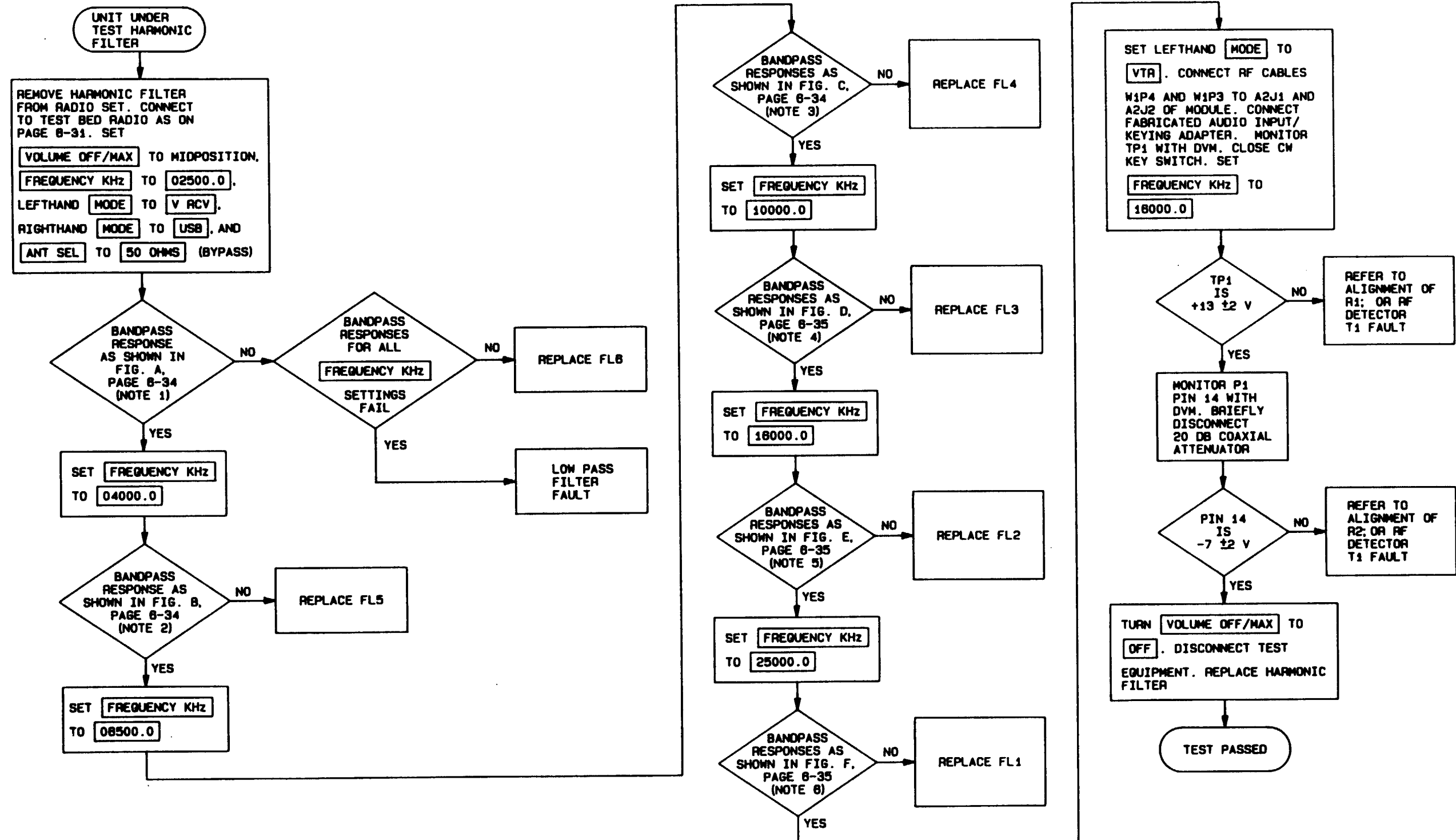

**HARMONIC FILTER FAULT ISOLATION PERFORMANCE TEST (3 of 4)**

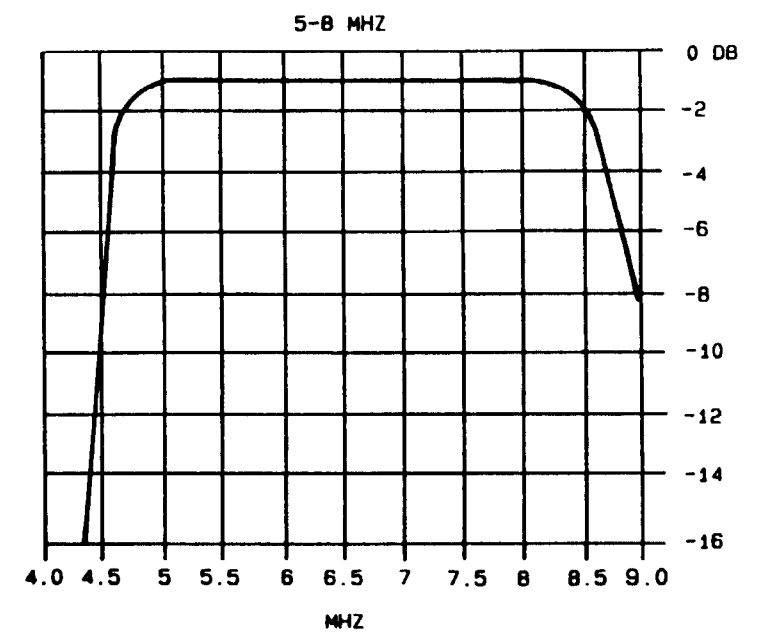
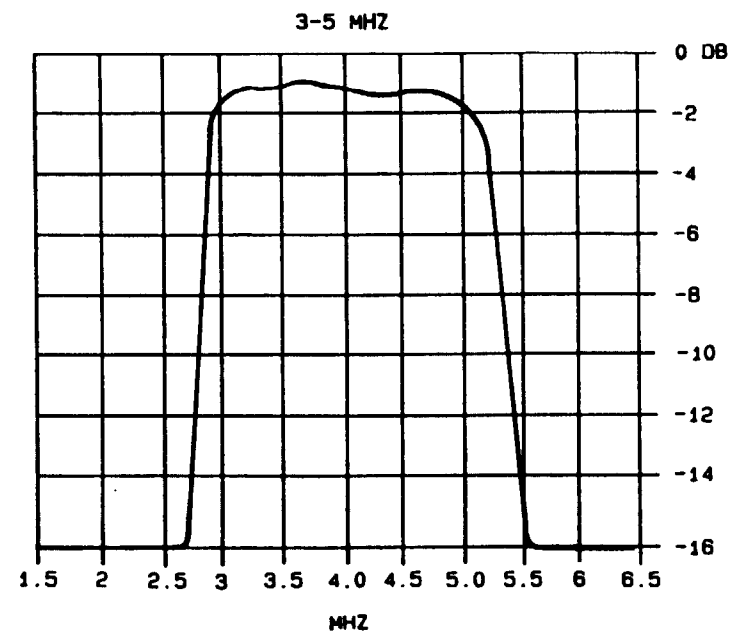
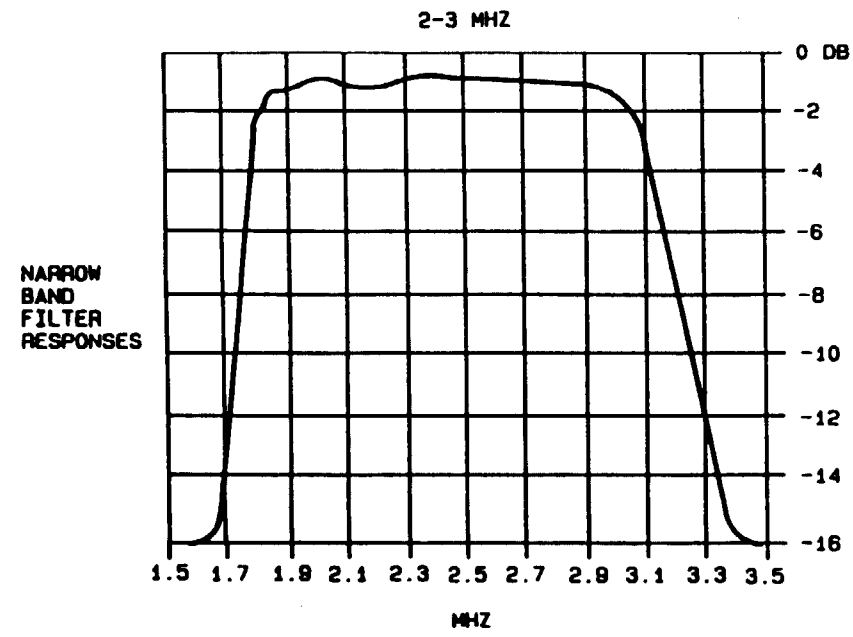

SPECTRUM ANALYZER SETTINGS IN PERFORMANCE TEST NOTES

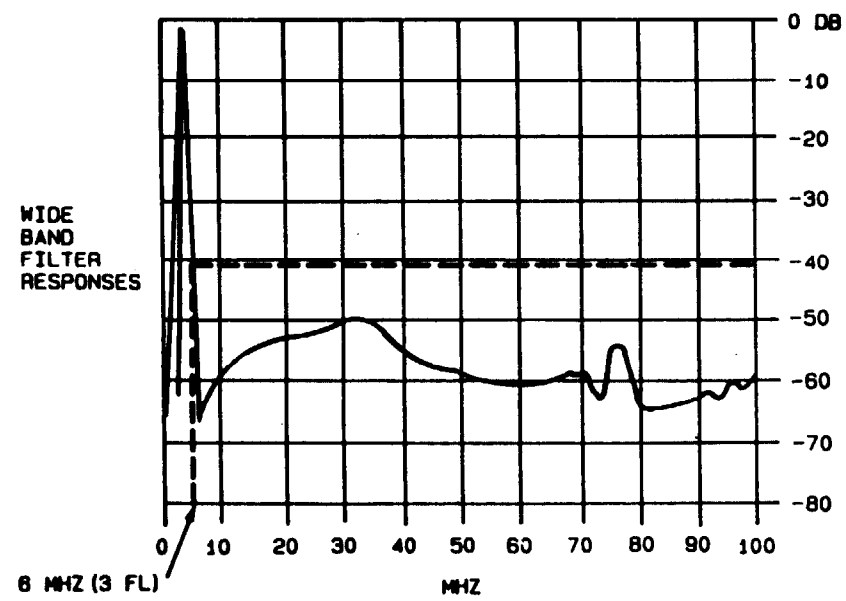

FIGURE A

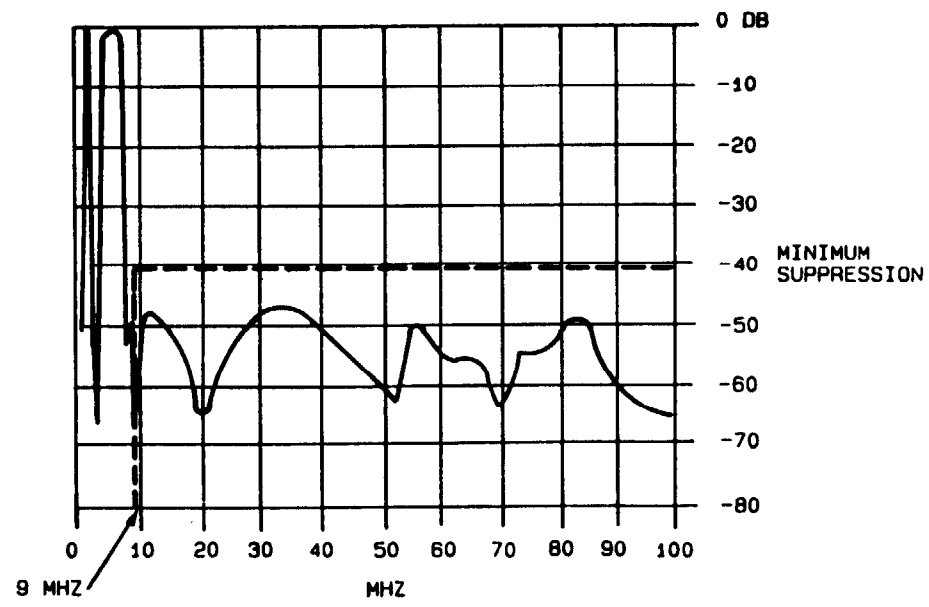

FIGURE B

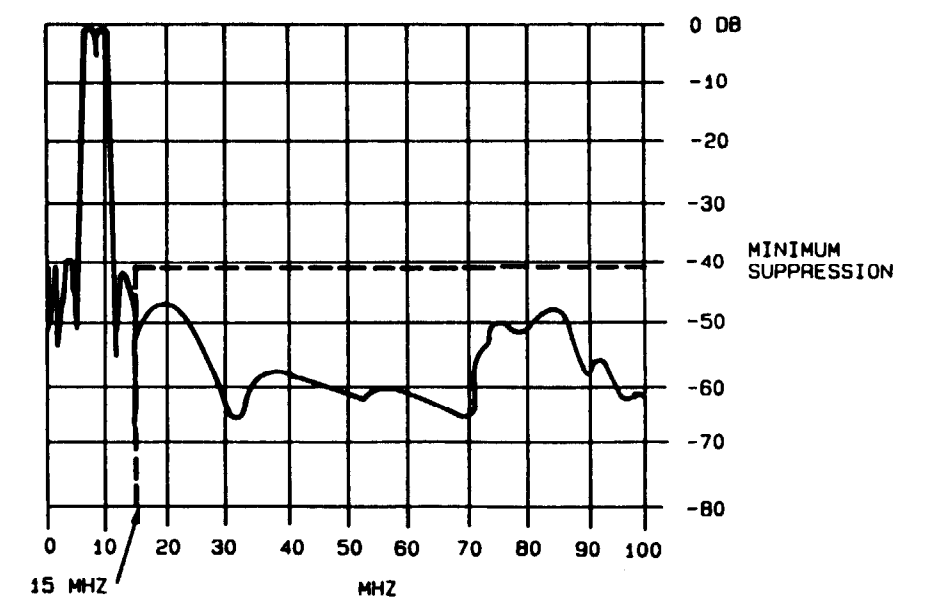

FIGURE C

**HARMONIC FILTER FAULT ISOLATION PERFORMANCE TEST (4 of 4)**

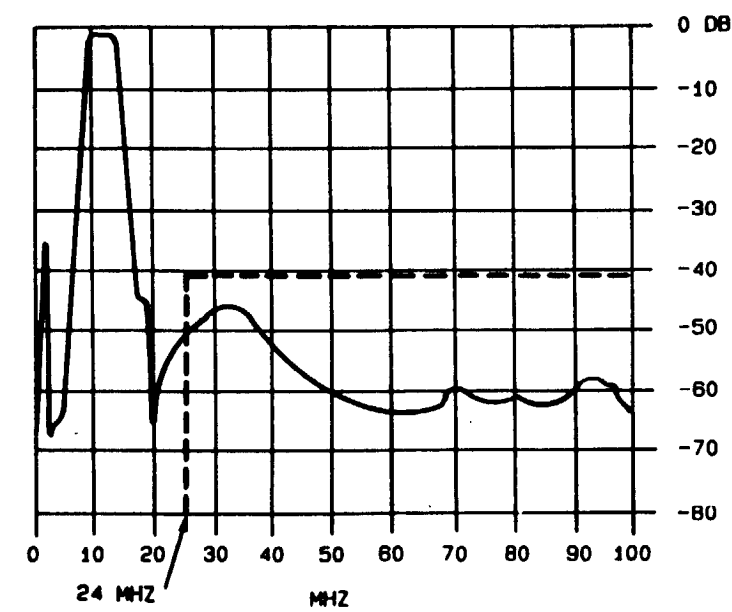
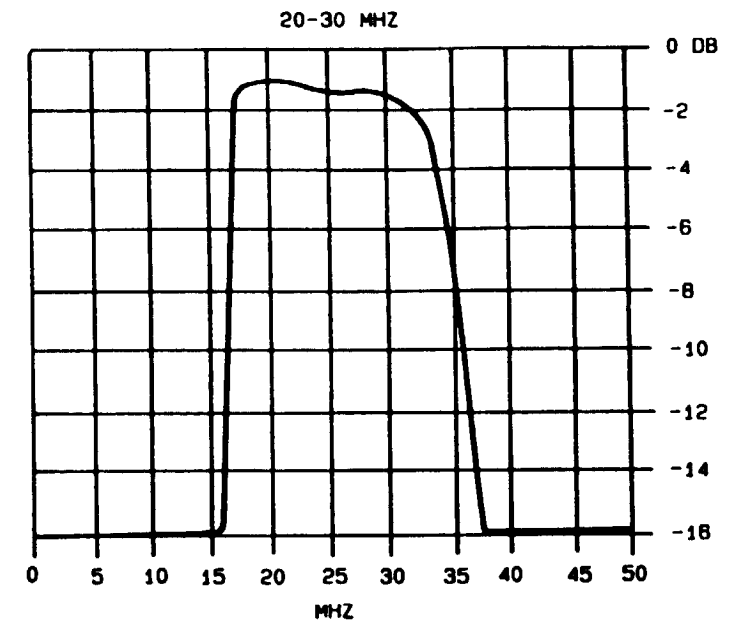
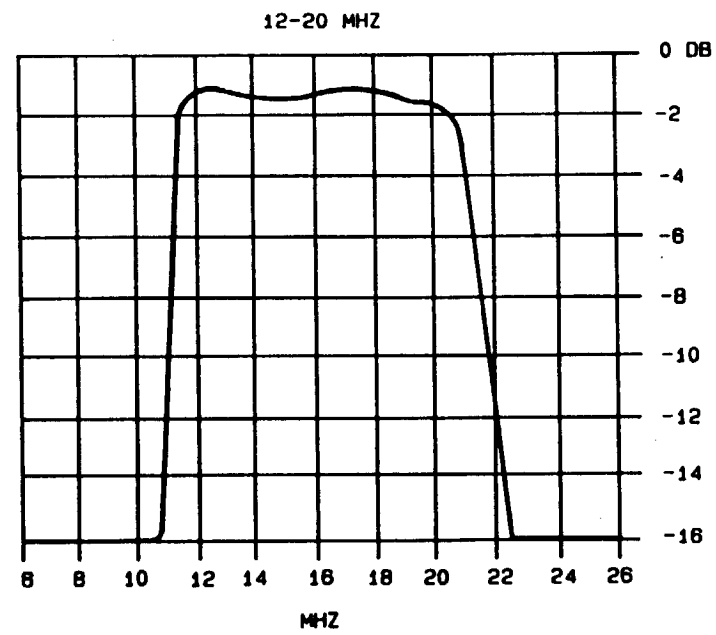
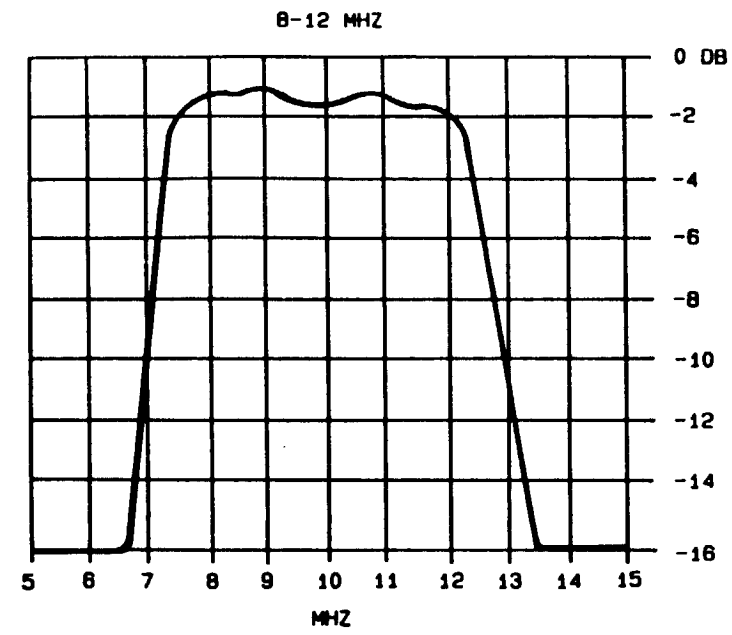

FIGURE D

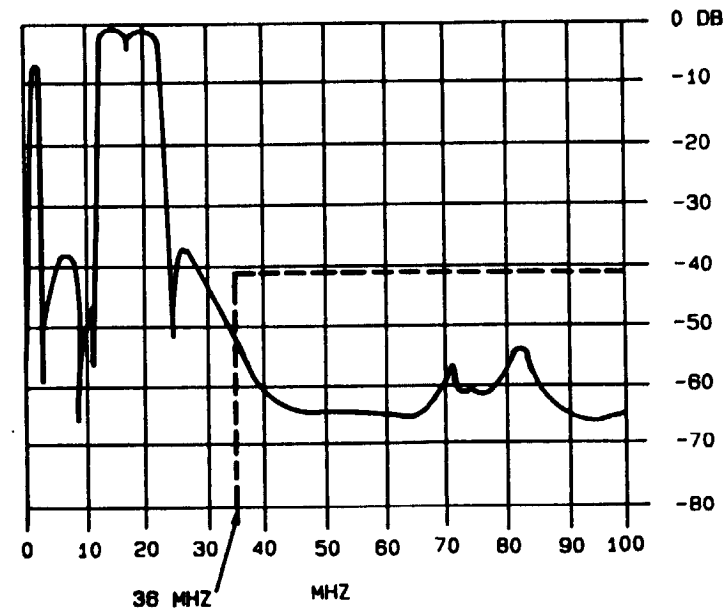

FIGURE E

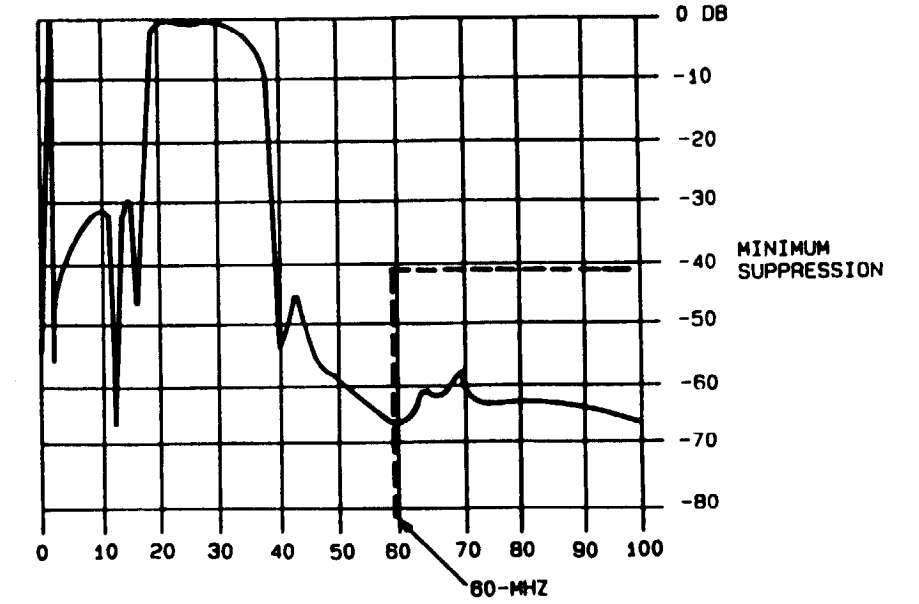

FIGURE F

**HARMONIC FILTER FAULT ISOLATION ALIGNMENT PROCEDURE (1 of 3), fig 6-16**

The alignment procedure is to be used in either of these situations (1) the performance test calls a potentiometer out of adjustment, or (2) the following is replaced: rf detector T1, CR1, CR2, CI, C2, C3, and C4. The procedure consists of special tools and test equipment, alignment setup, preliminary setup, and adjustment procedure.

**SPECIAL TOOLS AND TEST EQUIPMENT**

Description	Part Number
Harmonic Filter/Power Amplifier Test Extender Cable	...
RF Coax Cable (3 each)	...
Radio Set, Test Bed	AN/PRC-104
VTVM	
Signal Generator, RF	
Digital Multimeter (DVM, ohmmeter function)	
Dummy Load (50 ohms)	
Wattmeter	
— Power Meter	
— Thermocouple Power Sensor	
Power Supply, DC	
Power Supply, Current Limited	
Attenuator, Coaxial (20 db, 30 W min, 50 ohms)	Narda 765-20
Attenuator, Step	

**NOTE**

Refer to page 1-6 for test equipment characteristics.

**HARMONIC FILTER FAULT ISOLATION ALIGNMENT PROCEDURE (2 of 3)**

**ALIGNMENT SETUP**

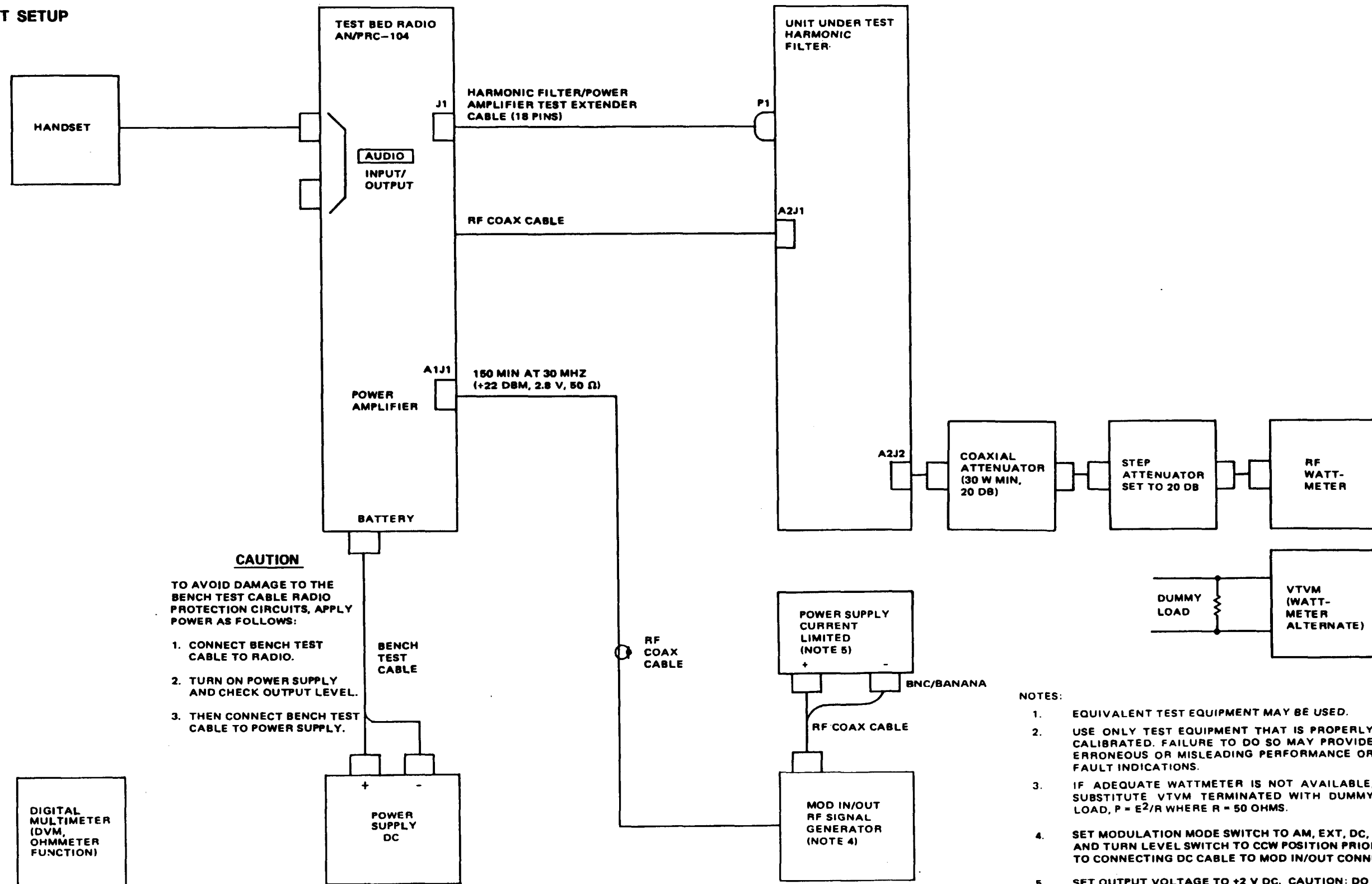

**CAUTION**  
 TO AVOID DAMAGE TO THE BENCH TEST CABLE RADIO PROTECTION CIRCUITS, APPLY POWER AS FOLLOWS:  
 1. CONNECT BENCH TEST CABLE TO RADIO.  
 2. TURN ON POWER SUPPLY AND CHECK OUTPUT LEVEL.  
 3. THEN CONNECT BENCH TEST CABLE TO POWER SUPPLY.

- NOTES:**
1. EQUIVALENT TEST EQUIPMENT MAY BE USED.
  2. USE ONLY TEST EQUIPMENT THAT IS PROPERLY CALIBRATED. FAILURE TO DO SO MAY PROVIDE ERRONEOUS OR MISLEADING PERFORMANCE OR FAULT INDICATIONS.
  3. IF ADEQUATE WATTMETER IS NOT AVAILABLE, SUBSTITUTE VTVM TERMINATED WITH DUMMY LOAD,  $P = E^2/R$  WHERE  $R = 50$  OHMS.
  4. SET MODULATION MODE SWITCH TO AM, EXT, DC, AND TURN LEVEL SWITCH TO CCW POSITION PRIOR TO CONNECTING DC CABLE TO MOD IN/OUT CONNECTOR.
  5. SET OUTPUT VOLTAGE TO +2 V DC. CAUTION: DO NOT EXCEED +5 V DC. SET CURRENT REGULATION TO MINIMUM REQUIRED TO PERFORM ALIGNMENT.

Figure 6-6. Harmonic Filter Fault Isolation Alignment Procedure

**HARMONIC FILTER FAULT ISOLATION ALIGNMENT PROCEDURE (3 of 3)**

**PRELIMINARY SETUP**

1. Remove the harmonic filter from the RT.
2. Remove the cover from the power amplifier module of the test bed radio set. Disconnect the rf radio coax A1J1 at the module and plug in the fabricated rf coax cable in its place
3. Connect the test radio, module, cables, and test equipment as shown on page 6-37. Comply with notes 1 thru 5 on page 6-37.
4. Select the rf signal generator frequency of 29.9999 MHz and an initial level output of 0 dbm at radio. Set dc power supply (7 amp) to +26.5 V.
5. Set the test radio controls on the control panel and amplifier/coupler as follows:
  - a. FREQUENCY KHz to 29999.9
  - b. Lefthand MODE to VTR
  - c. ANT SEL to 50 OHMS (bypass)
  - d. VOLUME OFF/MAX to midposition

**ADJUSTMENT**

1. Monitor VFWD, TP1, of the module using the test DVM and a sharp probe.
2. Close the PTT switch on the handset and adjust the rf signal generator output to +19 dbm, turn the modulation level control to obtain 20 W output (2 mW indicated on the wattmeter) from the harmonic filter module.
3. Adjust R1 to obtain +14.5  $\pm$ 0.1 V dc at TP1 of the module with 20 W module output.
4. Change the DVM monitor point from TP1 to A1A2P1 pin 14, VREFL (reflected voltage).
5. Adjust R2 to obtain the minimum voltage at pin 14. It should be between zero and -3.0 V dc.
6. Open the handset PTT switch.
7. Disconnect the +26.5 V dc input to the radio and remove the cables connected to the module.



**POWER SUPPLY FAULT ISOLATION**

The power supply fault Isolation procedure is divided into the following: special tools and test equipment, performance test setup, performance test, and alignment procedure.

**POWER SUPPLY FAULT ISOLATION SPECIAL TOOLS AND TEST EQUIPMENT**

Description	Part Number
Synthesizer Test Extender Cable	...
Audio Input/Keying Adapter	...
RF Extender Cable	...
Tool Kit, Electronic	TK-105/G
Bench Repair Center	Pace PRC-350C
Maintenance Kit, Printed Circuit	MK-984/A
Radio Set, Test Bed	AN/PRC-104
VTVM	
Digital Multimeter (DVM, ohmmeter function)	
Dummy Load (50 ohms)	
Wattmeter	
— Power Meter	
— Thermocouple Power Sensor	
Power Supply, DC	
Attenuator, Coaxial 20 db, 30 W min, 50 ohms	Narda 765-20
Multimeter	

NOTE

Refer to page 1-6 for test equipment characteristics.

**POWER SUPPLY FAULT ISOLATION PERFORMANCE TEST SETUP**

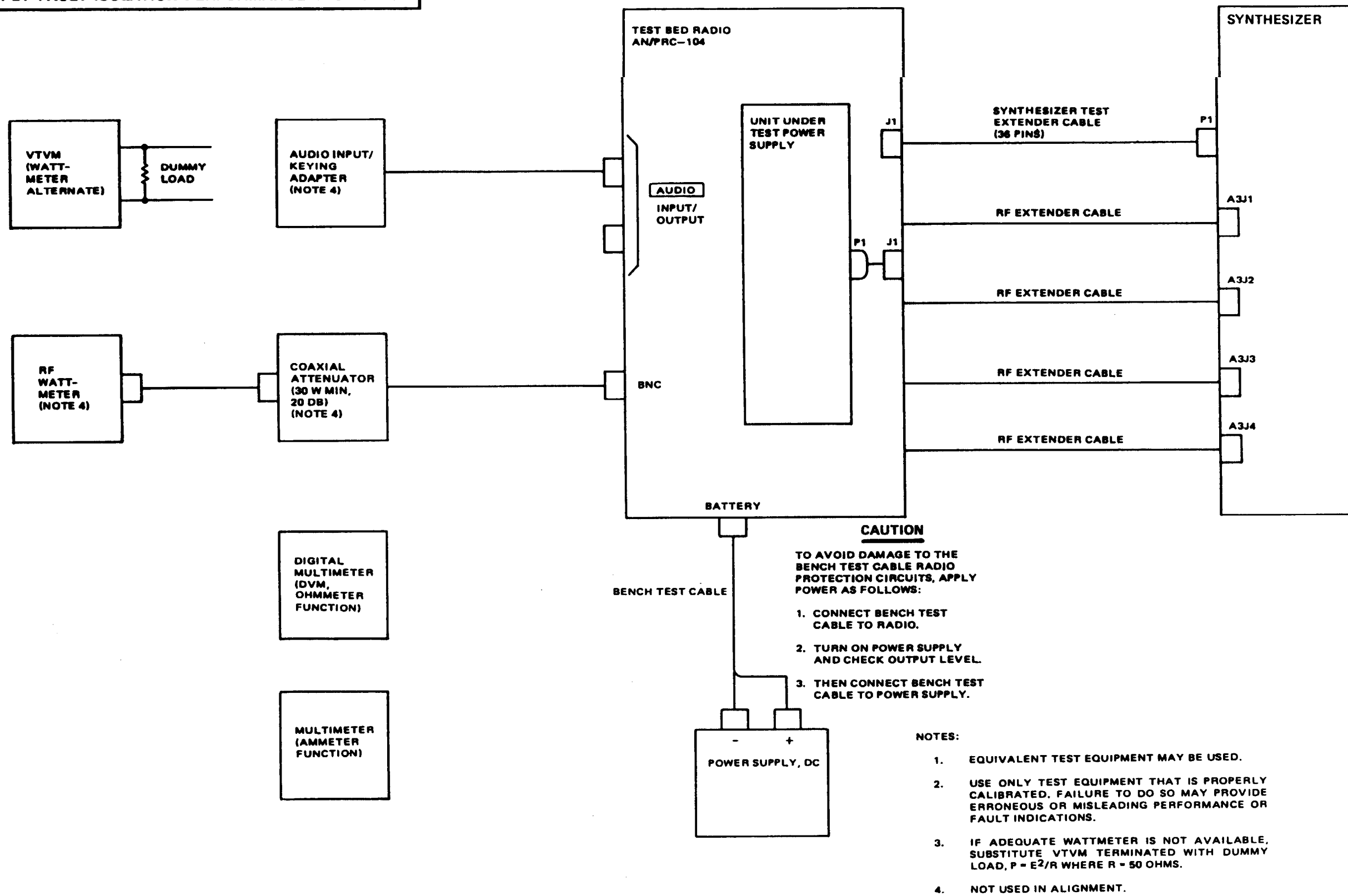
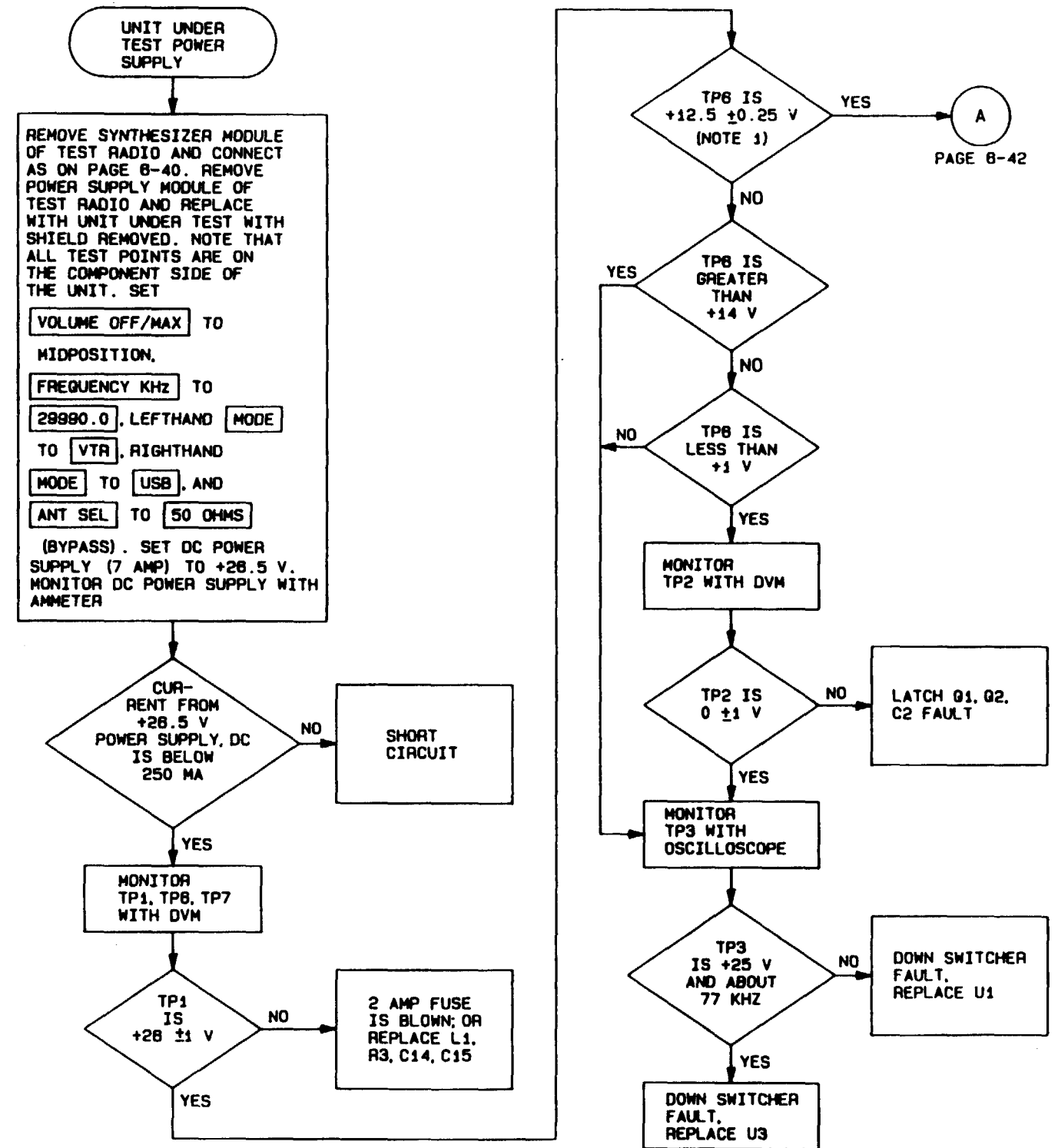

Figure 6-7. Power Supply Fault Isolation Performance Test Setup

**POWER SUPPLY FAULT ISOLATION PERFORMANCE TEST (1 of 2)**

**NOTES**

1. If voltage exceeds tolerance, refer to alignment of R17.
2. If voltage exceeds tolerance, refer to alignment of R24.
3. Unless otherwise specified, all voltage measurements taken with respect to chassis ground.



**POWER SUPPLY FAULT ISOLATION PERFORMANCE TEST (2 of 2)**

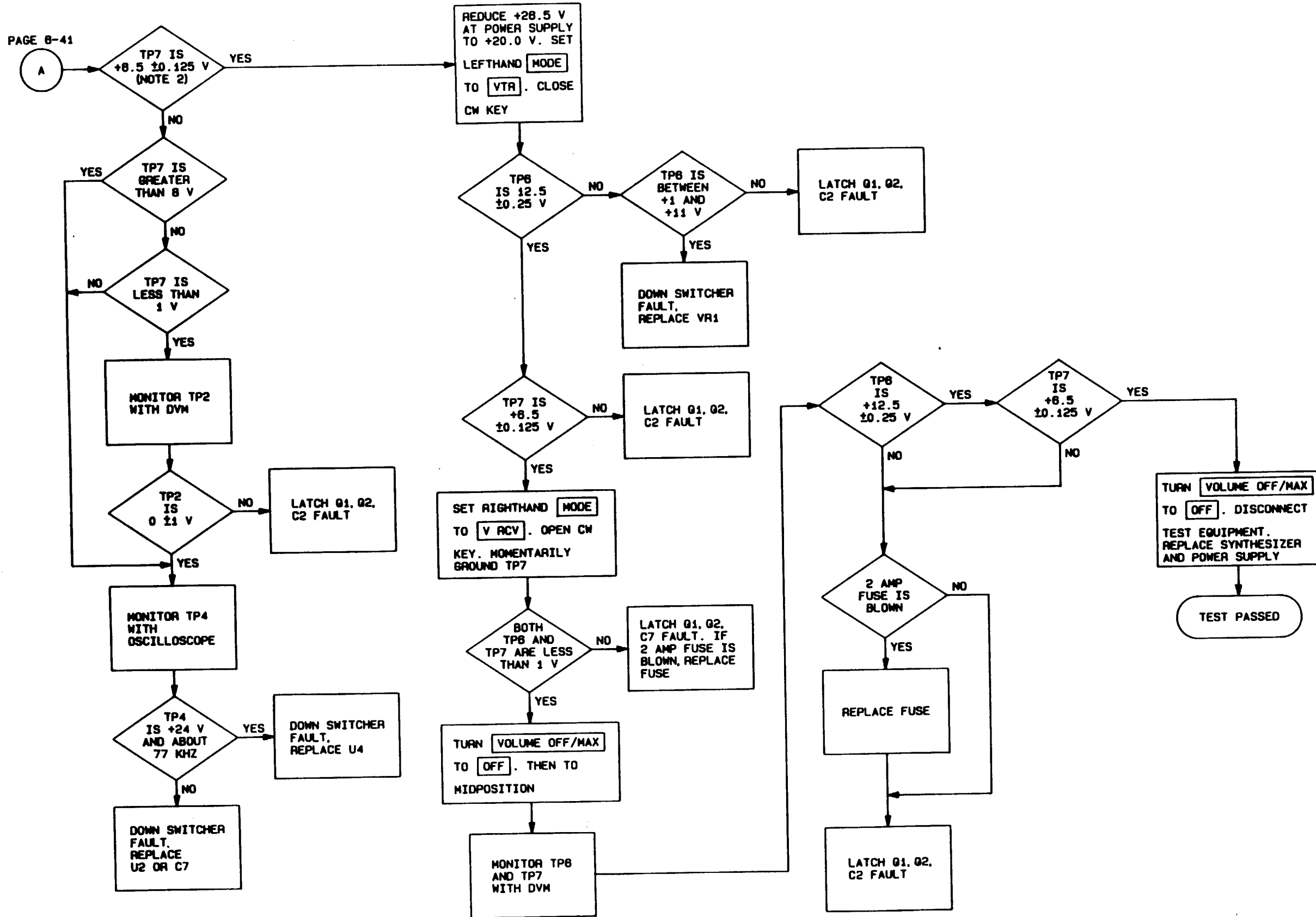

**POWER SUPPLY FAULT ISOLATION ALIGNMENT PROCEDURE**

The alignment procedure is to be used in either of these situations (1) the performance test calls a potentiometer out of adjustment, or (2) one of the following is replaced:

1. Timers U1, U2.
2. Switching Regulators U3, U4.
3. Diode VR1.
4. Capacitors C6, C7.

The procedure consists of special tools and test equipment, alignment setup, preliminary setup, and adjustment procedure.

**SPECIAL TOOLS AND TEST EQUIPMENT**

The special tools and test equipment required for the alignment procedure are the same as those listed in the table on page 6-39.

**ALIGNMENT SETUP**

The alignment setup is the same as the setup shown on page 6-40.

**PRELIMINARY SETUP**

1. Remove the synthesizer and the power supply from the RT.
2. Plug the power supply (unit to be aligned) into the test bed radio.
3. Except for the keying adapter and wattmeter, connect the test radio, cables, adapters, and test equipment as shown on page 6-39. Set the dc power supply (7 amp) to +26.5 V.
4. Set the following test radio controls as follows:
  - a. FREQUENCY KHz to 29990.0
  - b. Righthand MODE to USB
  - c. ANT SEL to 50 OHMS (bypass)
  - d. Lefthand MODE to VTR
  - e. VOLUME OFF/MAX to midposition

**ADJUSTMENT**

1. Monitor the voltage at TP7 of the module and adjust R24 to obtain +6.50 V.
2. Monitor the voltage at TP6 of the module and adjust R17 to obtain +12.50 V.
3. Turn the radio off and disconnect the test equipment.

BLANK  
INTENTIONALLY

Section II. RT COMPONENT LOCATION

	Page		Page
General .....	6-45	Second Frequency Converter Component Location .....	6-52
EFP Component Location .....	6-46	Third Frequency Converter Component Location .....	6-53
Synthesizer Component Location .....	6-49	Harmonic Filter Component Location .....	6-54
Modulator/Demodulator Component Location .....	6-50	Power Supply Component Location .....	6-55
First Frequency Converter Component Location .....	6-51		

**GENERAL**

This section contains parts location diagrams and parts lists for the RT modules. This information is provided for the EFP, synthesizer, modulator/demodulator, harmonic filter, and power supply.

**EFP COMPONENT LOCATION (1 of 3)**

CONTROL PANEL INTERFACE ANALOG SUBASSEMBLY

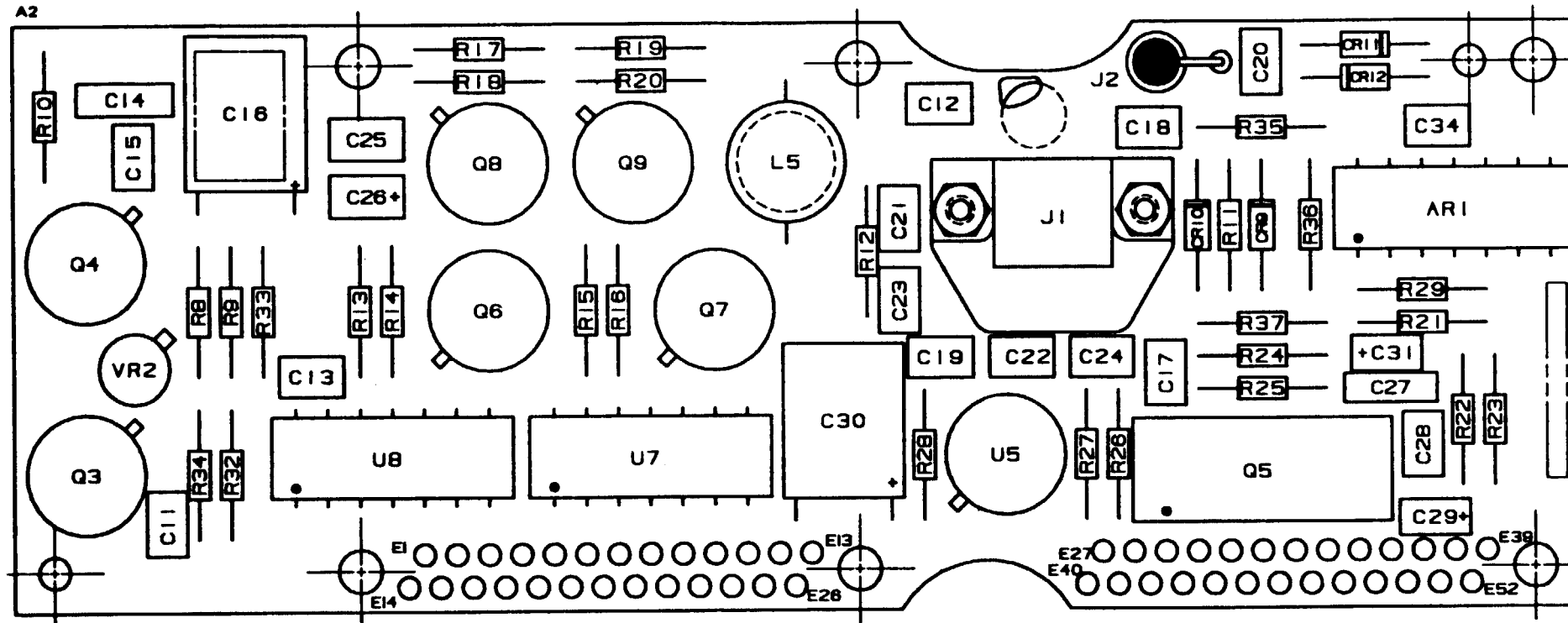

  
ATTENTION  
STATIC SENSITIVE  
DEVICE  
HANDLING  
PRECAUTIONS REQUIRED  
755002C0430

Figure 6-8. EFP Component Location (Sheet 1)





**EFP COMPONENT LOCATION (3 of 3)**

AUDIO FILTER

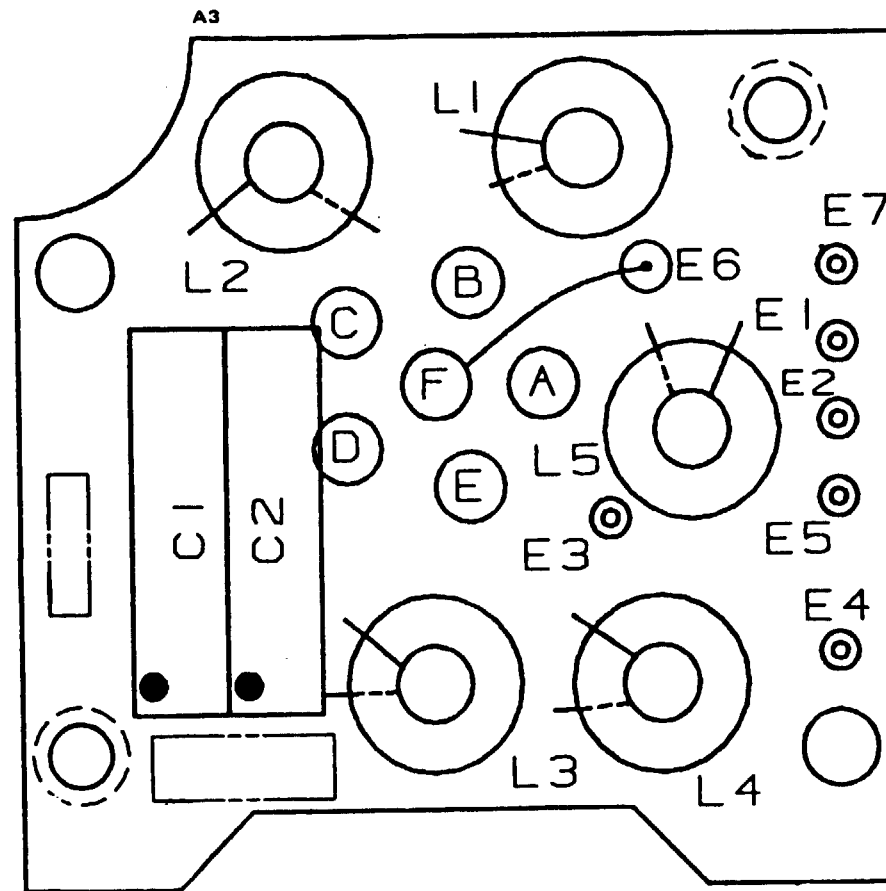

  
**ATTENTION**  
STATIC SENSITIVE  
DEVICE  
HANDLING  
PRECAUTIONS REQUIRED

75502C0475

Figure 6-6. EFP Component Location (Sheet 3)

**SYNTHESIZER COMPONENT LOCATION**

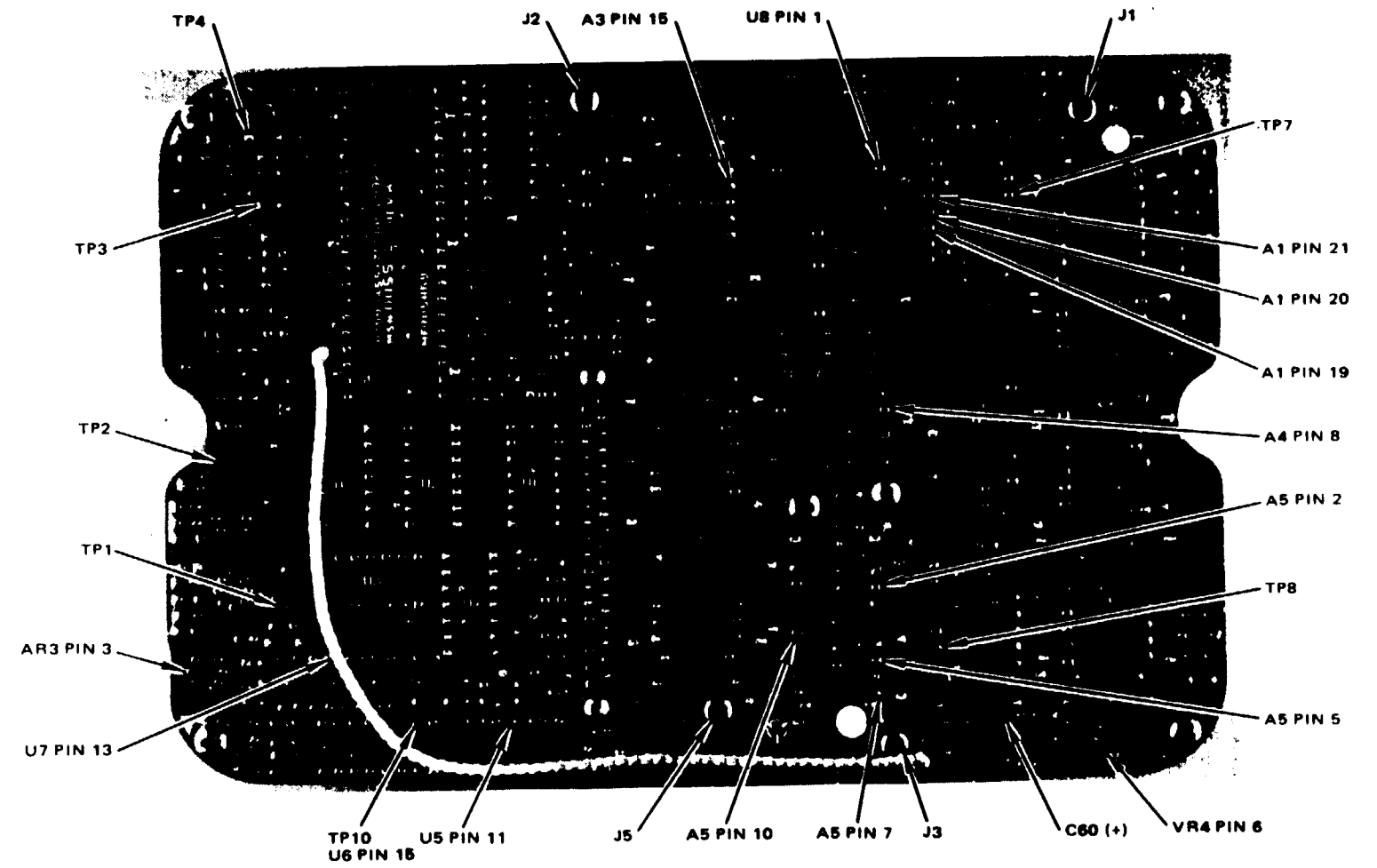
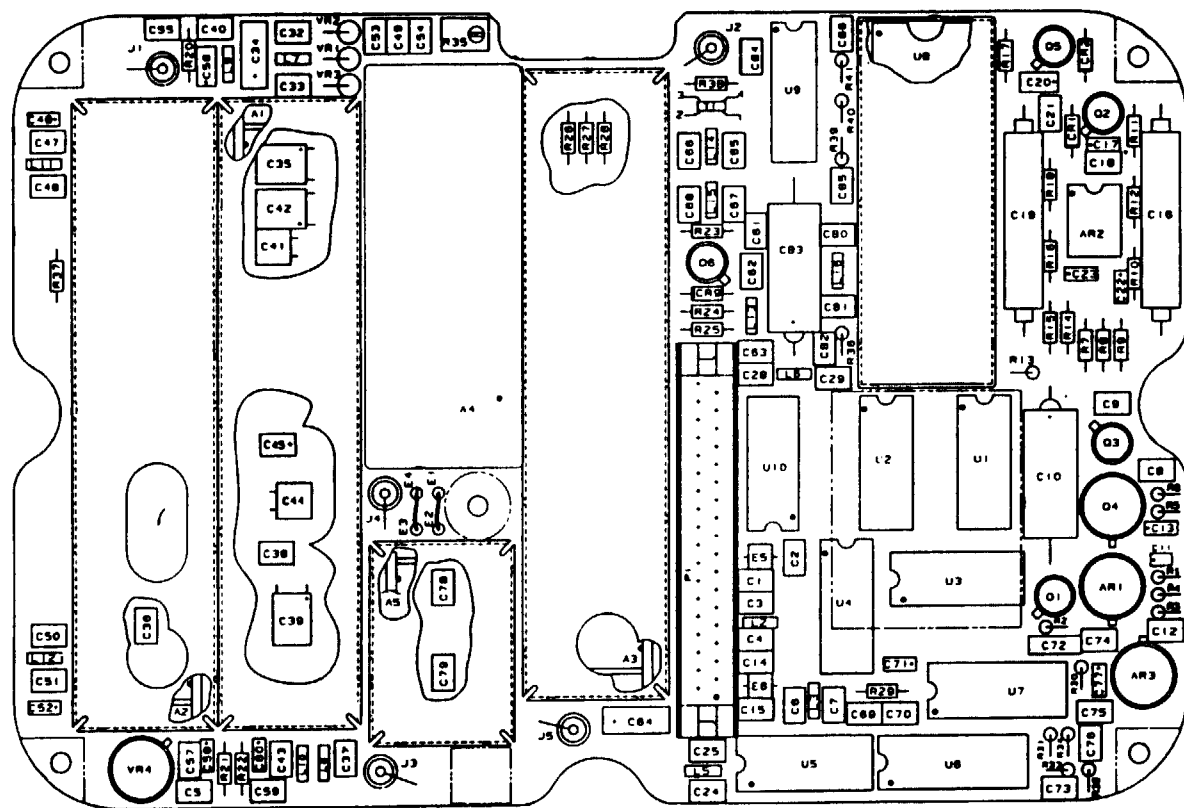

  
**ATTENTION**  
 STATIC SENSITIVE  
 DEVICE  
 HANDLING  
 PRECAUTIONS REQUIRED  
 785002C0320

Figure 6-9. Synthesizer Component Location

**MODULATOR/DEMODULATOR COMPONENT LOCATION**

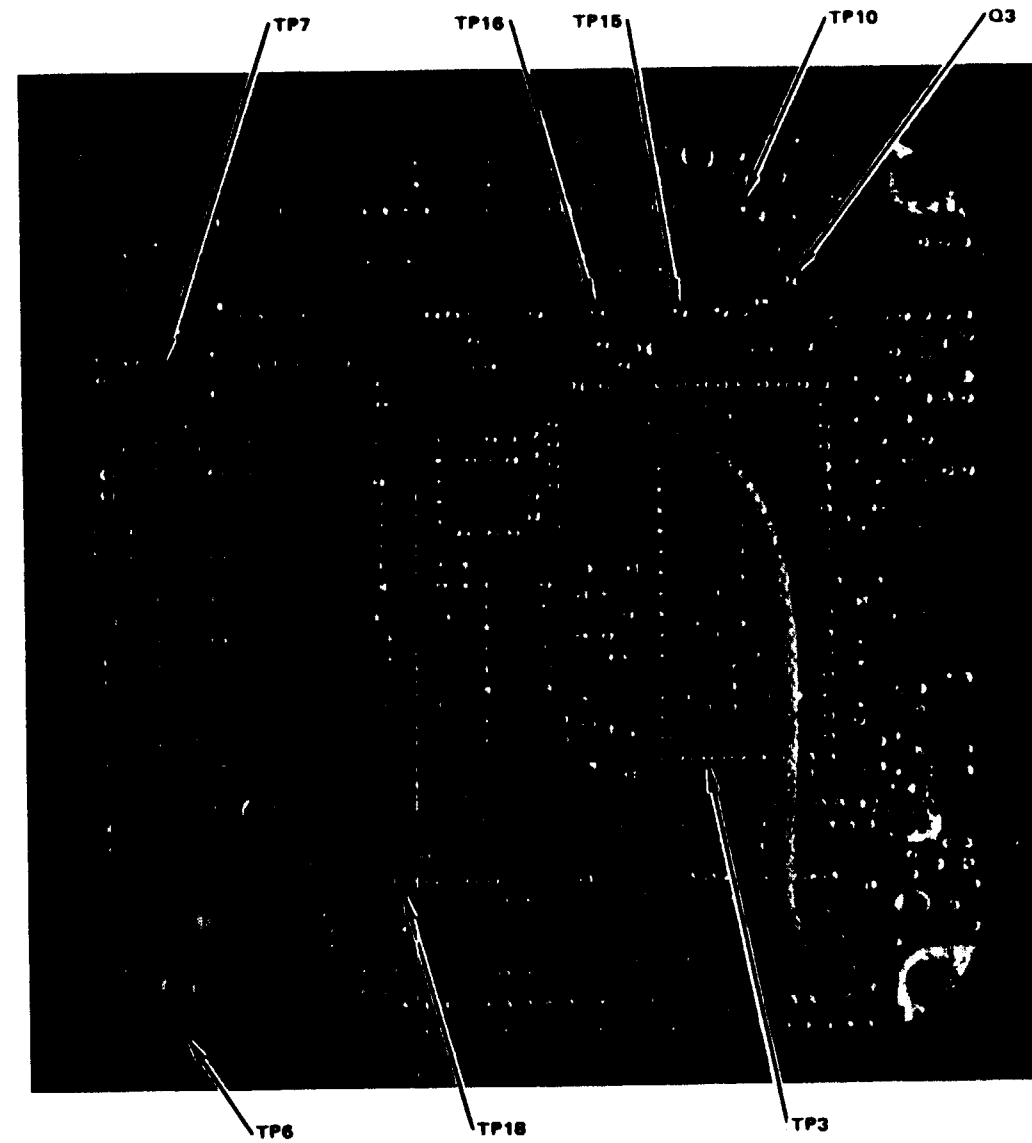
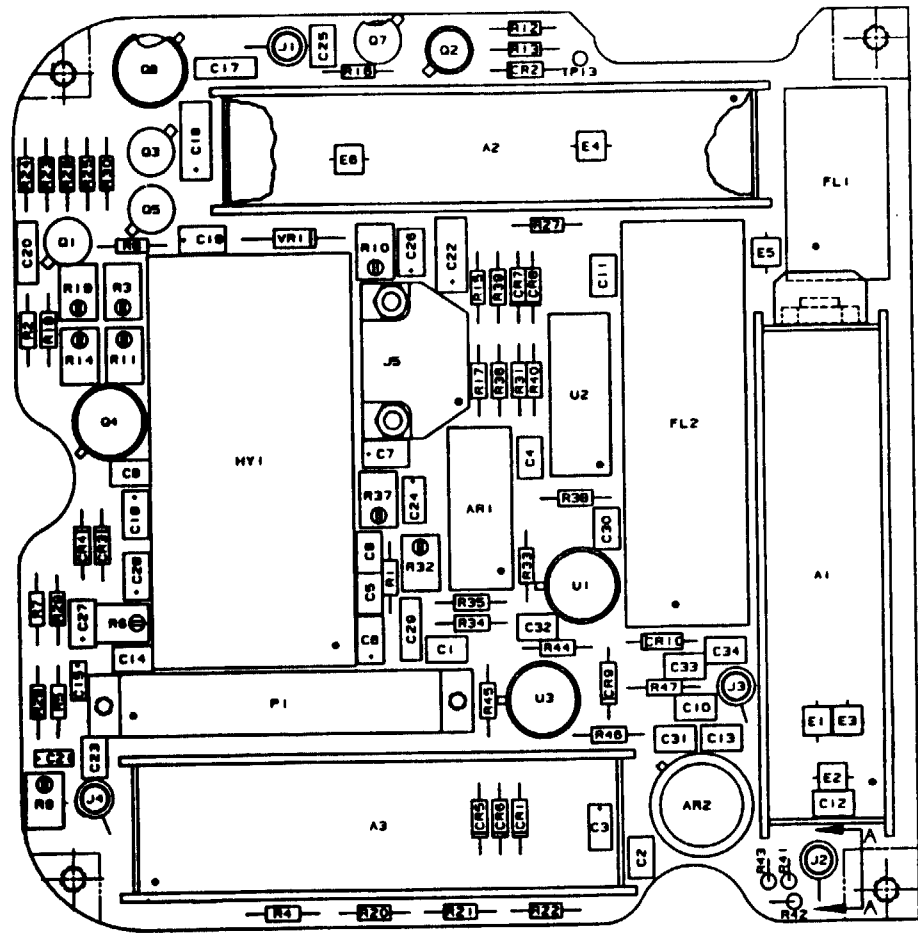

ATTENTION  
STATIC SENSITIVE  
DEVICE  
HANDLING  
PRECAUTIONS REQUIRED  
755002C0220

Figure 6-10. Modulator/Demodulator Component Location

**FIRST FREQUENCY CONVERTER COMPONENT LOCATION**

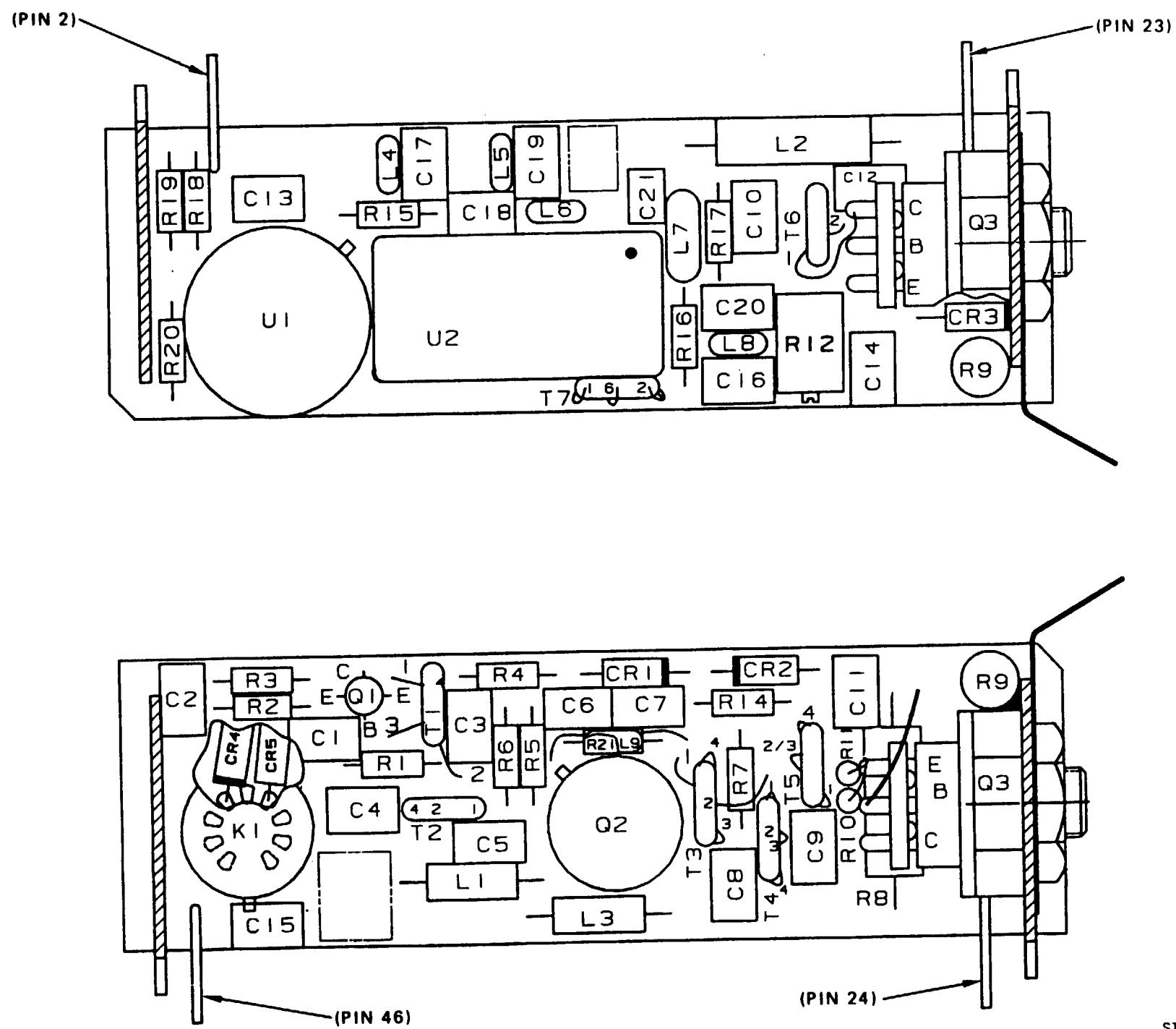

  
**ATTENTION**  
 STATIC SENSITIVE  
 DEVICE  
 HANDLING  
 PRECAUTIONS REQUIRED  
 785002C0230

Figure 6-11. First Frequency Converter Component Location

**SECOND FREQUENCY CONVERTER COMPONENT LOCATION**

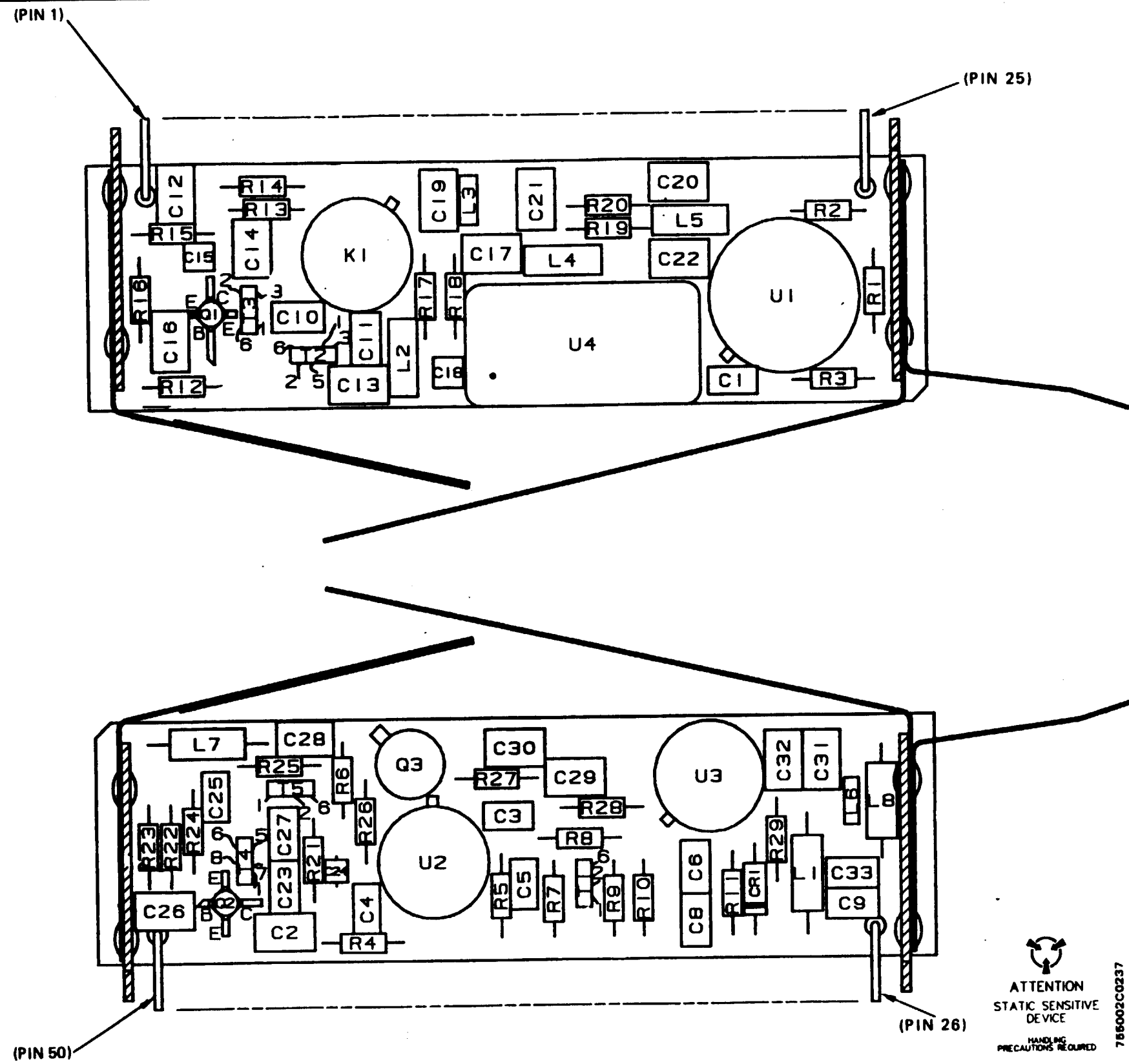

ATTENTION  
 STATIC SENSITIVE  
 DEVICE  
 HANDLING  
 PRECAUTIONS REQUIRED

786002C0237

Figure 6-12. Second Frequency Converter Component Location

THIRD FREQUENCY CONVERTER COMPONENT LOCATION

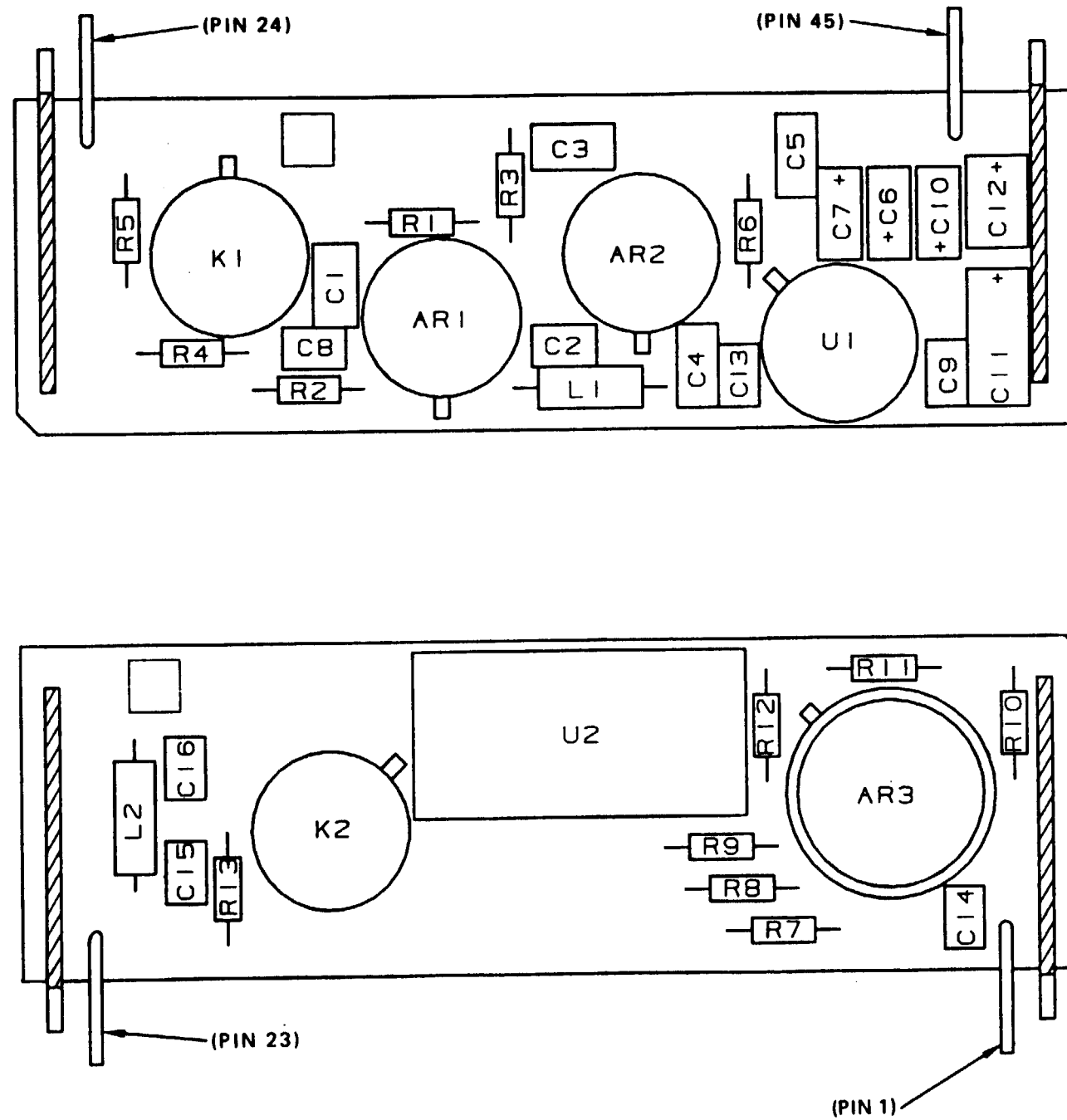

ATTENTION  
STATIC SENSITIVE  
DEVICE  
HANDLING  
PRECAUTIONS REQUIRED

786002C0243

Figure 6-13. Third Frequency Converter Component Location

**HARMONIC FILTER COMPONENT LOCATION**

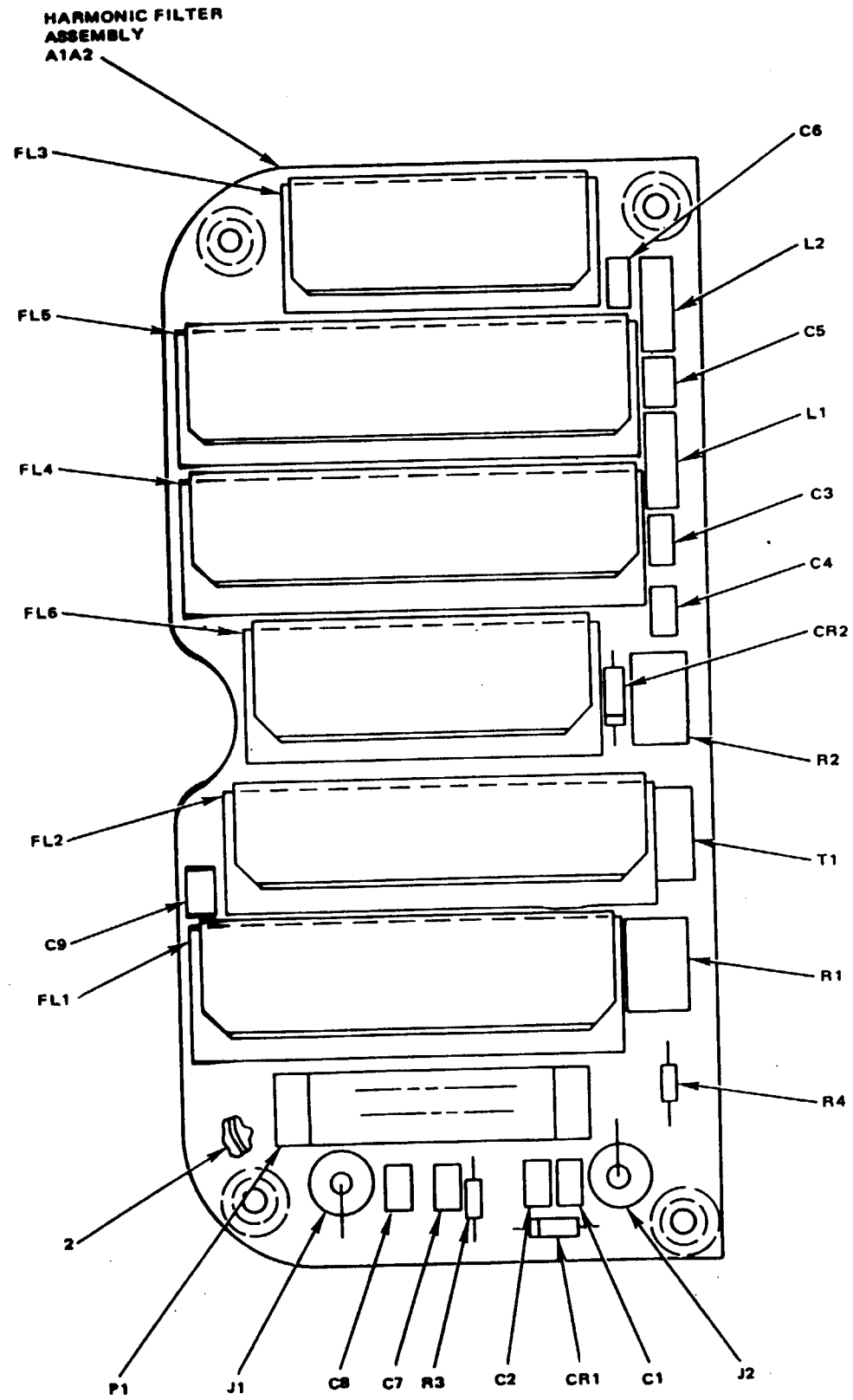
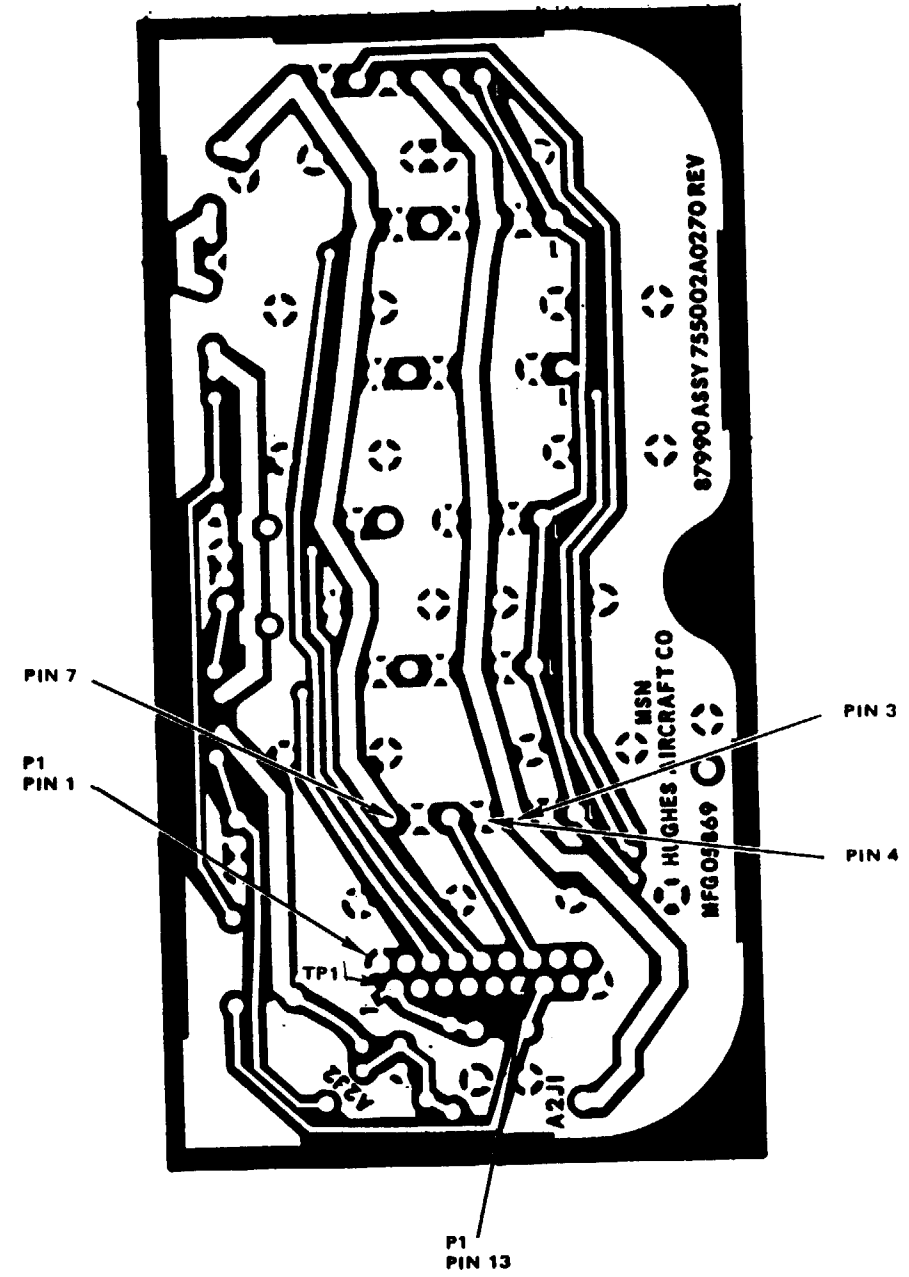

Figure 6-14. Harmonic Filter Component



NOTE: 3 DENOTES TEST POINT 3 ETC.



**POWER SUPPLY COMPONENT LOCATION**

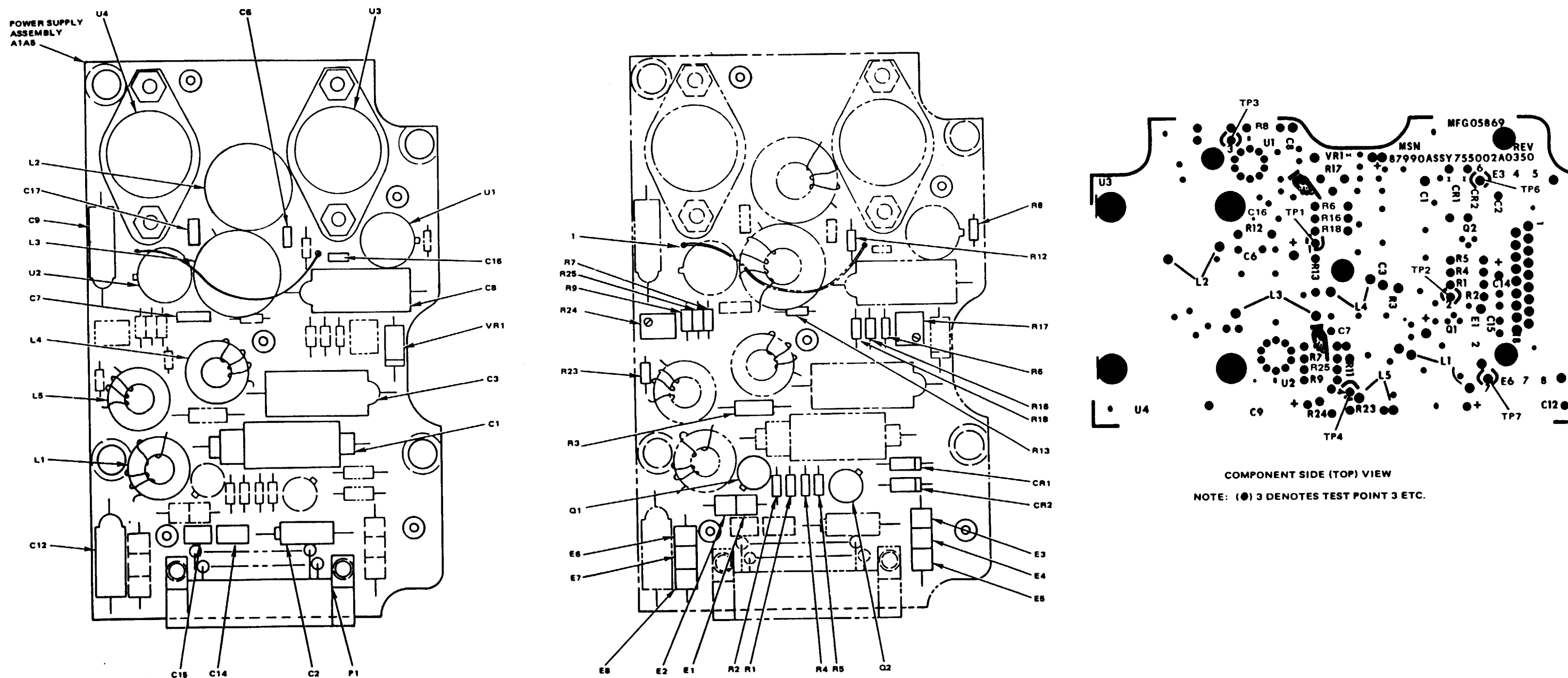

Figure 6-15. Power Supply Component Location

755002A0350

BLANK  
INTENTIONALLY

Section III. RT SCHEMATIC DIAGRAMS

	Page		Page
General .....	6-57	Modulator/Demodulator Schematic Diagram .....	6-76
RT Schematic Diagram .....	6-58	First Frequency Converter Schematic Diagram .....	6-78
EFP Schematic Diagram .....	6-60	Second Frequency Converter Schematic Diagram .....	6-79
Synthesizer Schematic Diagram .....	6-65	Third Frequency Converter Schematic Diagram .....	6-80
Ramp Generator Schematic Diagram .....	6-70	Harmonic Filter Schematic Diagram .....	6-81
70/80 MHz Voltage-Controlled Oscillator (VCO) Schematic Diagram .....	6-72	Power Supply Schematic Diagram .....	6-82
77-105 MHz Voltage-Controlled Oscillator (VCO) Schematic Diagram .....	6-74		

**GENERAL**

This section contains detailed schematic diagrams to be used by the technician to troubleshoot the RT. Schematic diagrams are provided for the EFP, synthesizer, modulator/demodulator harmonic filter, and power supply.

**RT SCHEMATIC DIAGRAM (1 of 2)**

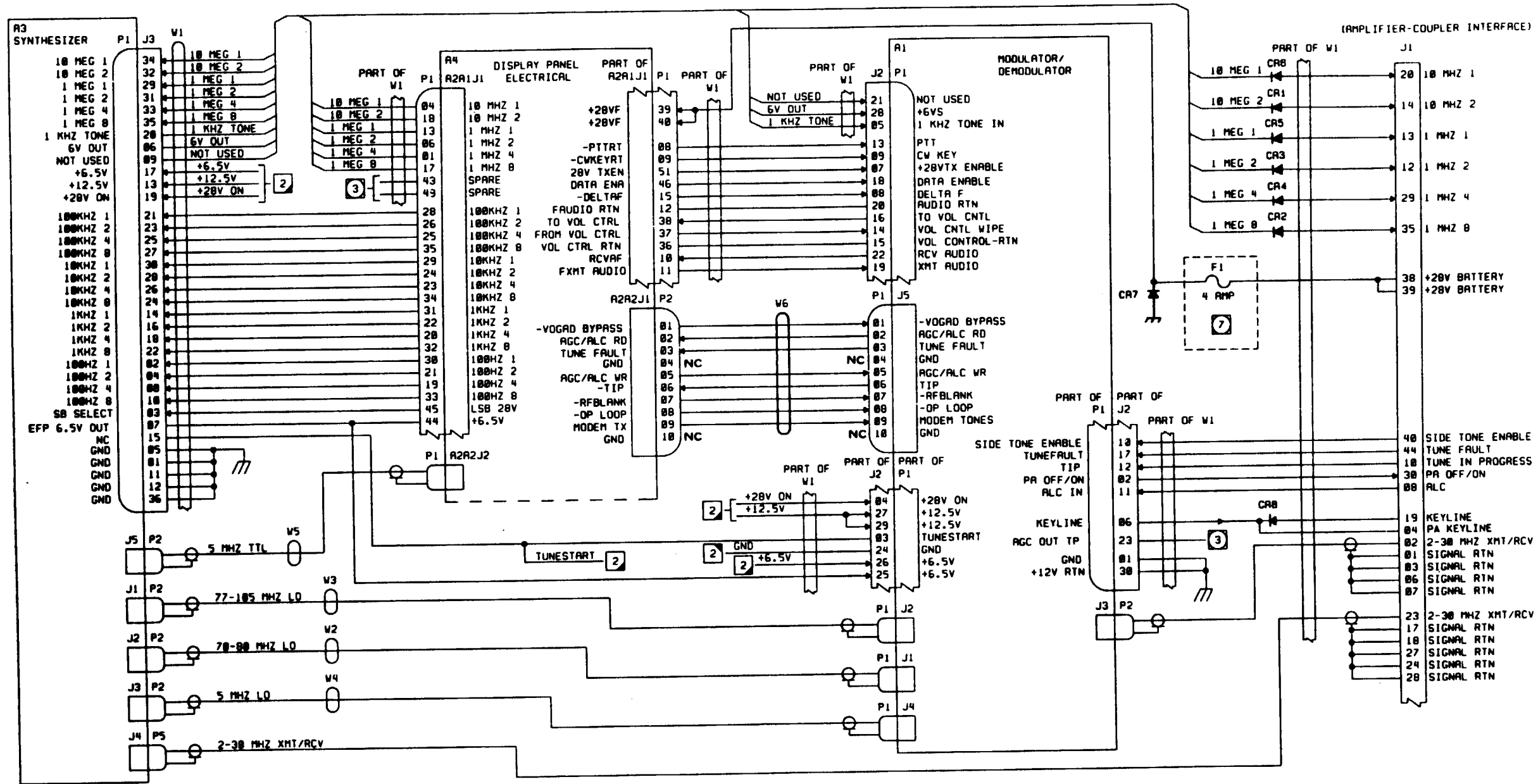

NOTES: UNLESS OTHERWISE SPECIFIED.

1. FOR ASSEMBLY SEE 755002C0150.
2. A SQUARE SYMBOL WITH SHADED CORNER(S) AND A NUMBER ENCLOSED INDICATES THE SHEET AND QUADRANT FOR THE ASSOCIATED CONNECTION(S).
3. TERMINALS SHOWN WITHOUT CONNECTION(S) ARE NOT USED.
4. A CIRCLE WITHIN A SQUARE SYMBOL MEANS: SEE NOTE NUMBER INDICATED.
5. PARTIAL REFERENCE DESIGNATIONS ARE SHOWN. FOR COMPLETE DESIGNATION, PREFIX WITH UNIT NUMBER OR SUBASSEMBLY DESIGNATION.
6. FOR TEST SPECIFICATION SEE 755002C0153.
7. NOT PART OF 755002A0120.
8. CA1 THRU CA8 ARE ON ASSEMBLY 755002A0120.

REFERENCE DESIGNATION	
HIGHEST NO. USED	NUMBERS NOT USED
A5	
F1	
W6	
CA8	

**ATTENTION**  
 STATIC SENSITIVE DEVICE  
 HANDLING PRECAUTIONS REQUIRED

Figure 6-16. RT Schematic Diagram (Sheet 1)

**RT SCHEMATIC DIAGRAM (2 of 2)**

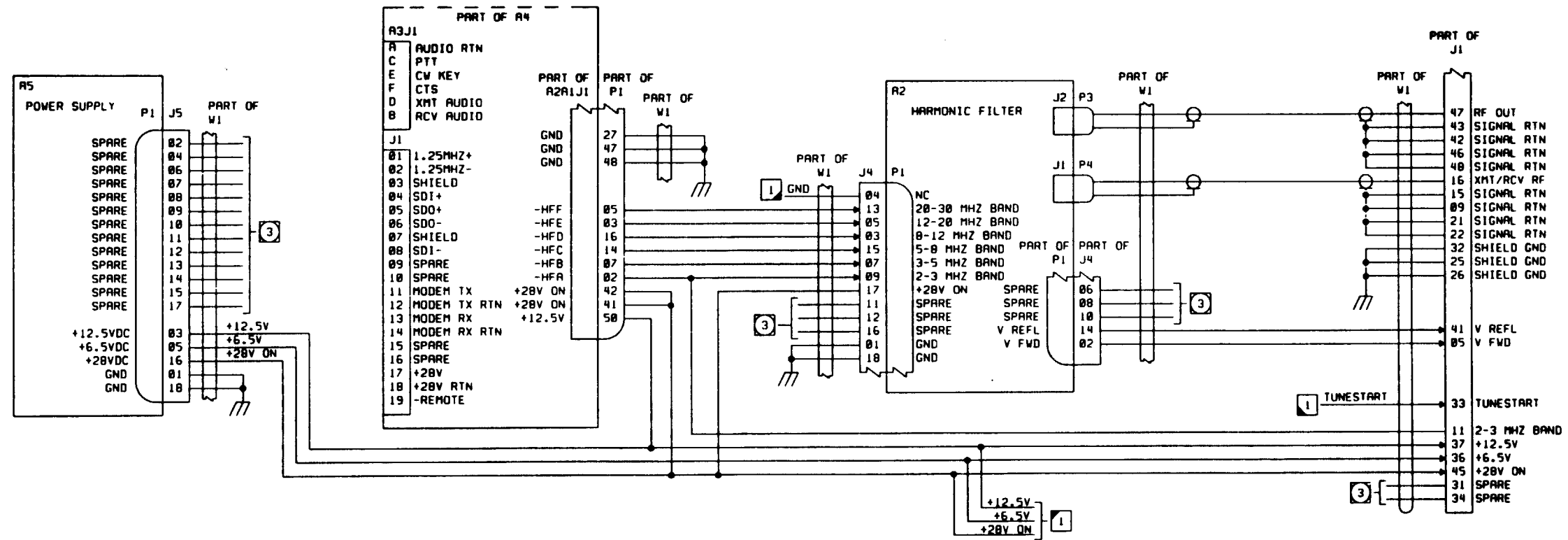
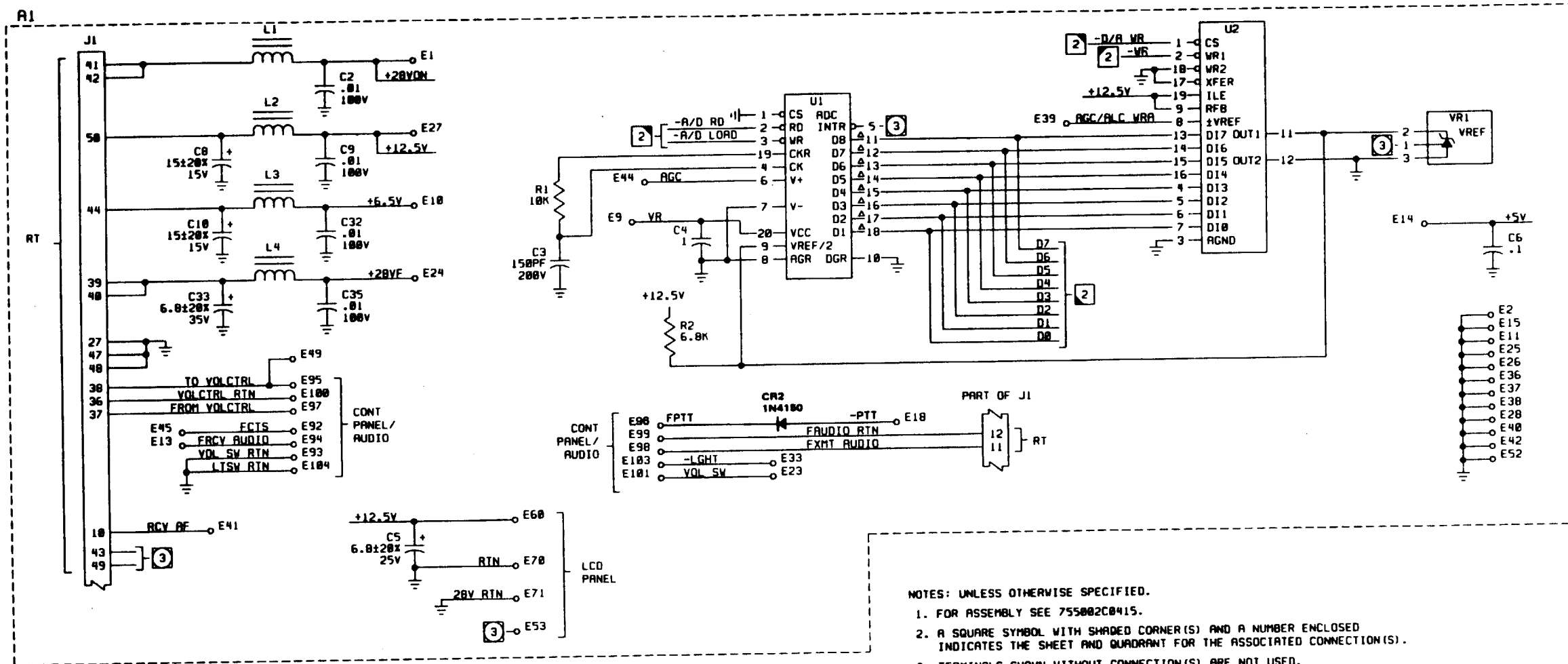

Figure 6-16. RT Schematic Diagram (Sheet 2)

**EFP SCHEMATIC DIAGRAM (1 of 5)**

INTERFACE CONTROL PANEL



- NOTES: UNLESS OTHERWISE SPECIFIED.
1. FOR ASSEMBLY SEE 755002C0415.
  2. A SQUARE SYMBOL WITH SHADED CORNER(S) AND A NUMBER ENCLOSED INDICATES THE SHEET AND QUADRANT FOR THE ASSOCIATED CONNECTION(S).
  3. TERMINALS SHOWN WITHOUT CONNECTION(S) ARE NOT USED.
  4. A CIRCLE WITHIN A SQUARE SYMBOL MEANS: SEE NOTE NUMBER INDICATED.
  5. RESISTANCE VALUES ARE IN OHMS PLUS OR MINUS 2X.1/8W.
  6. CAPACITANCE VALUES ARE IN MICROFARADS PLUS OR MINUS 10X.50V.
  7. PARTIAL REFERENCE DESIGNATIONS ARE SHOWN. FOR COMPLETE DESIGNATION, PREFIX WITH UNIT NUMBER OR SUBASSEMBLY DESIGNATION.
  8. WHEN SIGNALS WITH WIDE DISTRIBUTION (SUCH AS CLOCK AND SOFT VCC) ORIGINATE ON SHEET 1, SYMBOLS FOR THE ASSOCIATED CONNECTIONS ARE NOT SHOWN.
  9. THE SYMBOLS  $\Delta$   $\diamond$   $\nabla$  INDICATE A PIN TO BE TRISTATE, BIDIRECTIONAL OR BIDIRECTIONAL-TRISTATE, RESPECTIVELY.
  10. FOR TEST SPECIFICATION SEE 755002C0417.
  11. L1 THRU L4 ARE 14 TURNS AVG NO. 31 ON 3E2A CORE.

  
**ATTENTION**  
 STATIC SENSITIVE  
 DEVICE  
 HANDLING  
 PRECAUTIONS REQUIRED

755002C0416

Figure 6-17. EFP Schematic Diagram (Sheet 1)

**EFP SCHEMATIC DIAGRAM (2 of 5)**

INTERFACE CONTROL PANEL

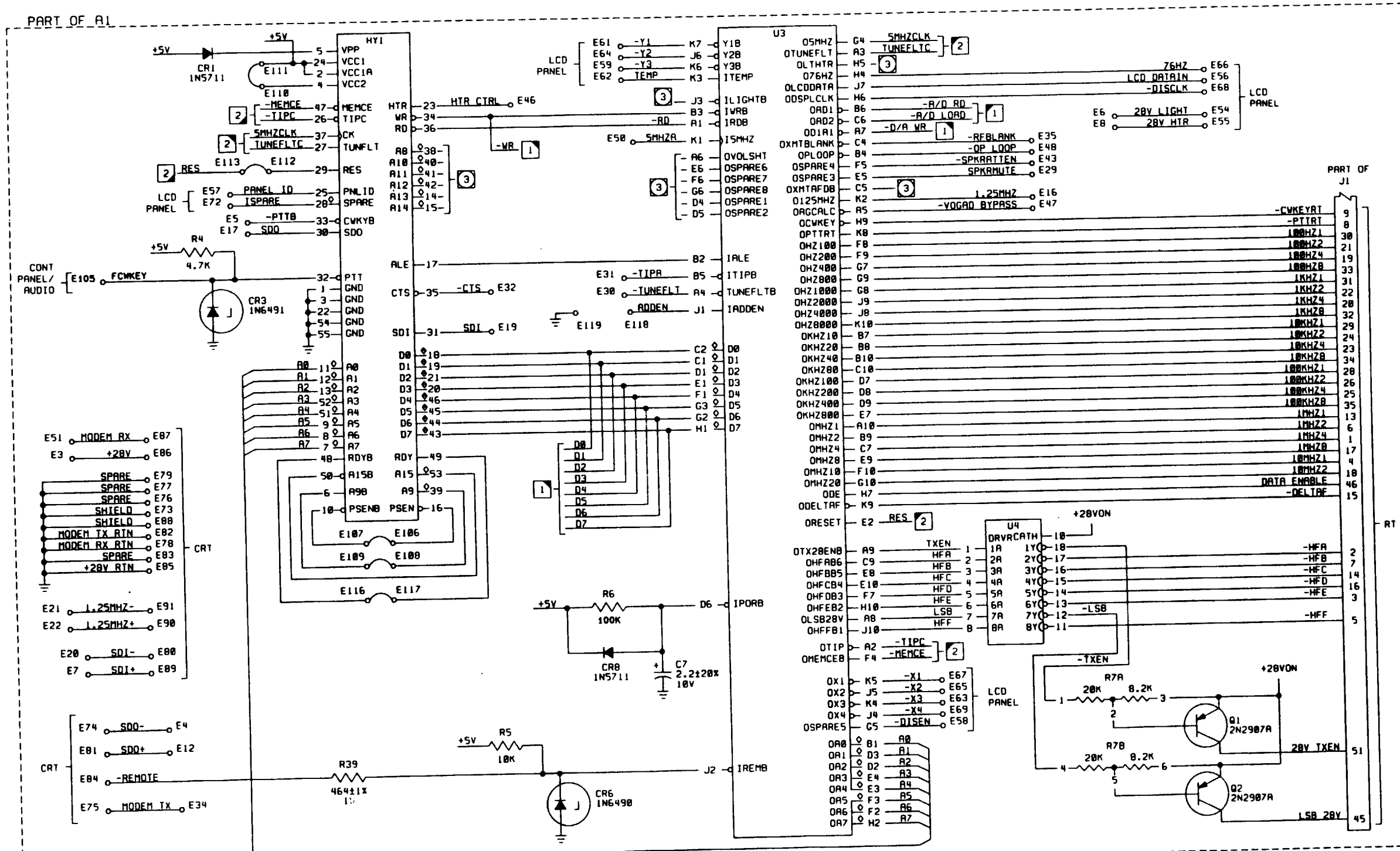
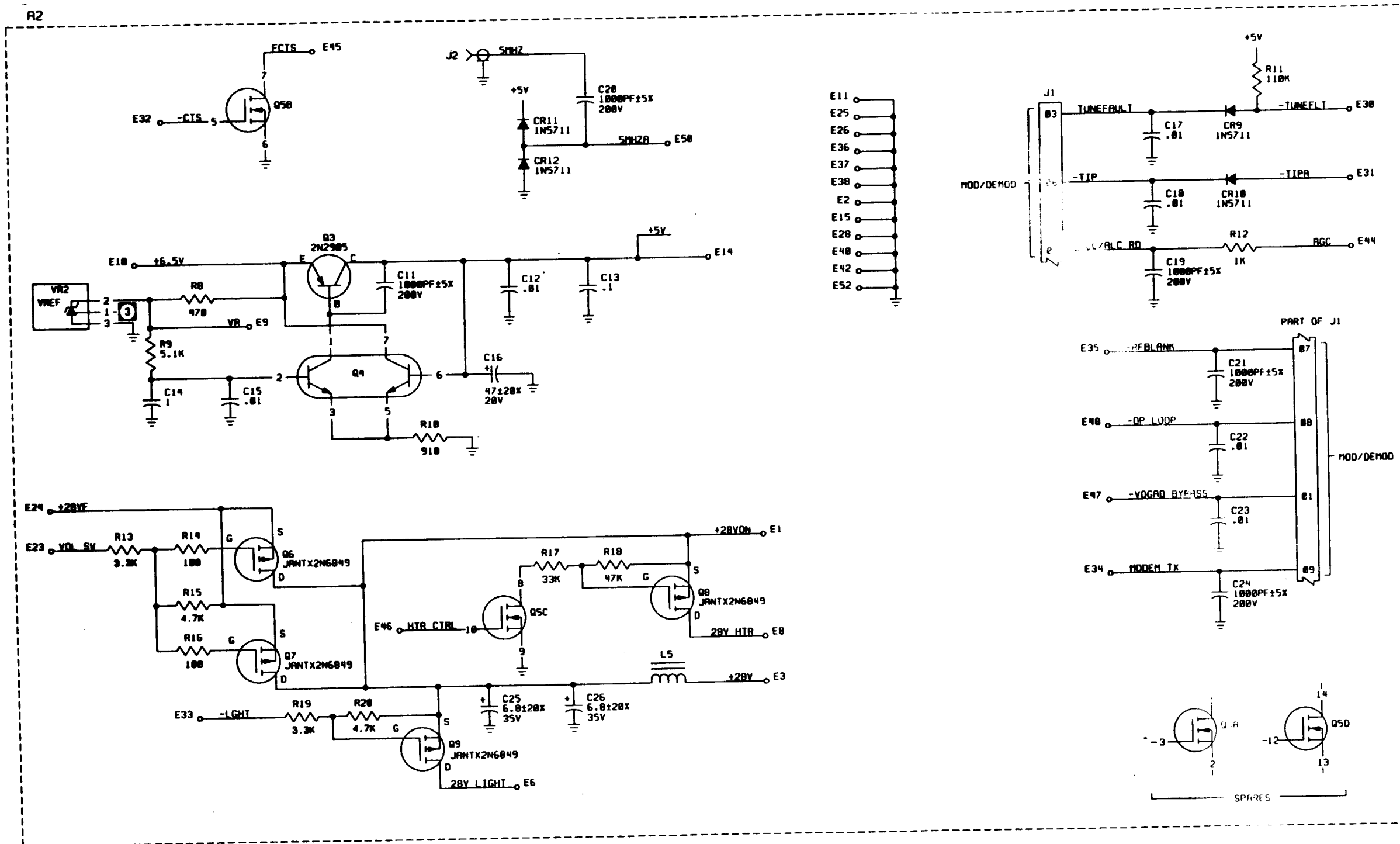

Figure 6-17. EFP Schematic Diagram (Sheet 2)

**EFP SCHEMATIC DIAGRAM (3 of 5)**

INTERFACE CONTROL PANEL



76002C0416

Figure 6-17. EFP Schematic Diagram (Sheet 3)



**EFP SCHEMATIC DIAGRAM (4 of 5)**

**INTERFACE CONTROL PANEL**

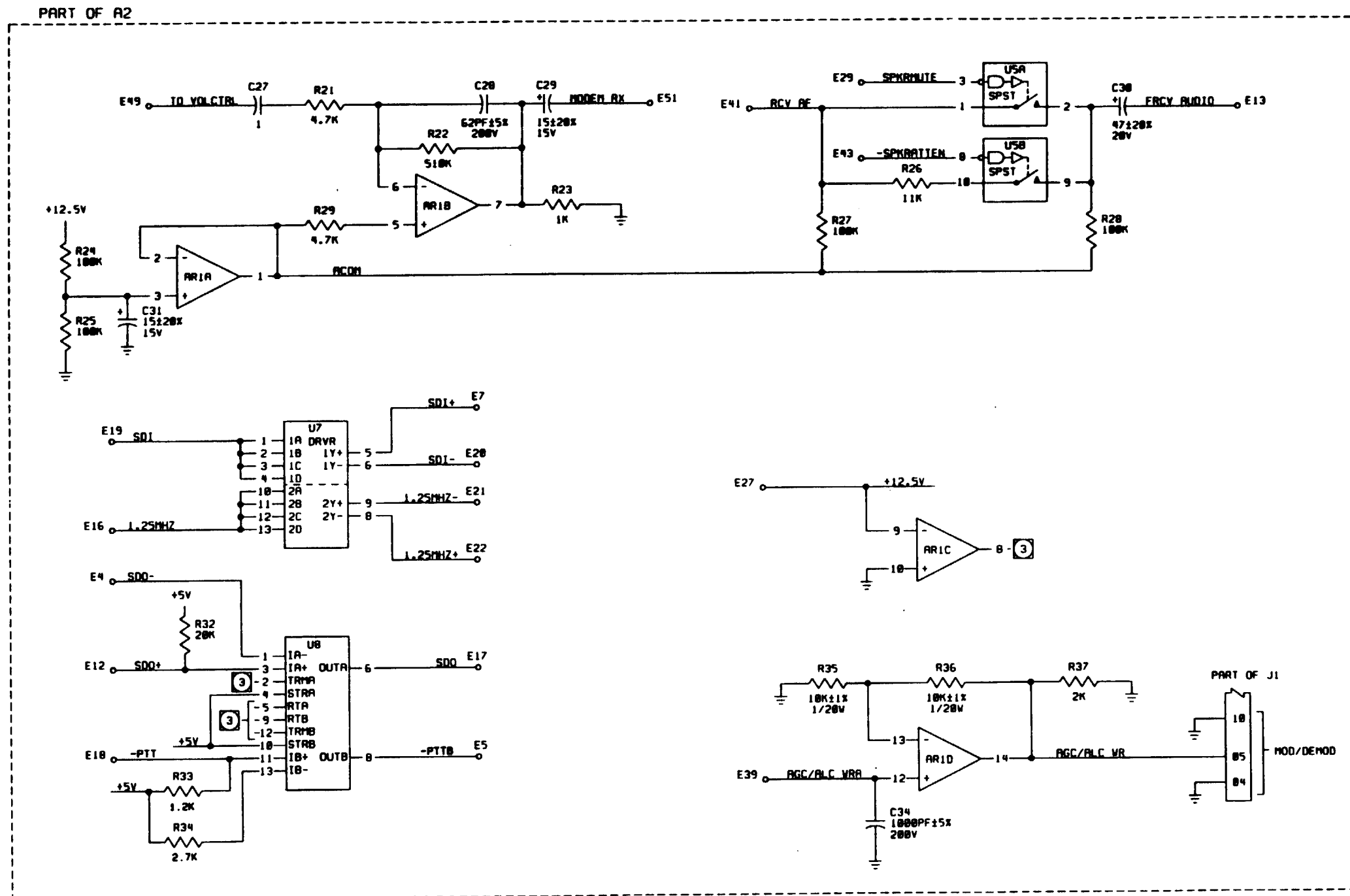
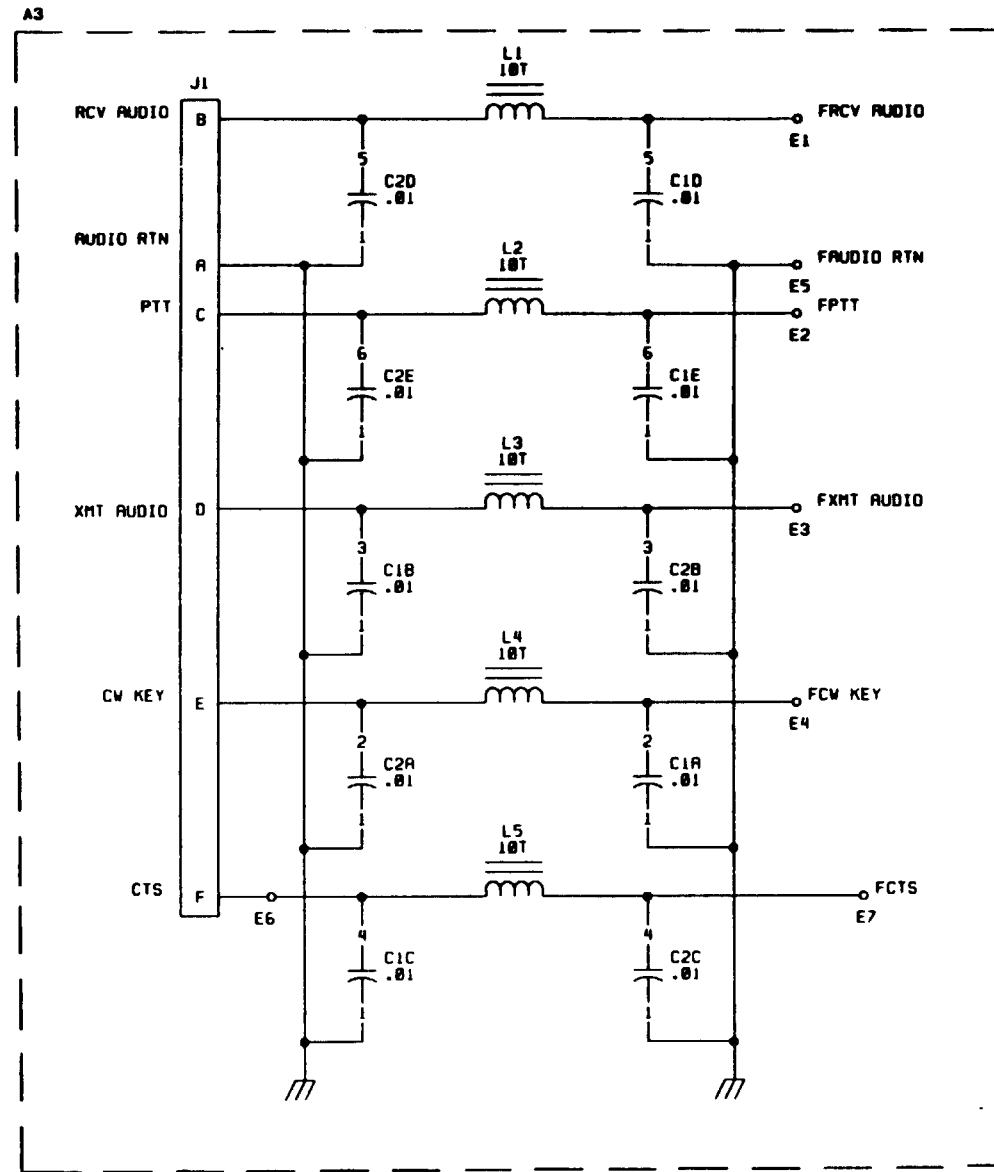

Figure 6-17. EFP Schematic Diagram (Sheet 4)

**EFP SCHEMATIC DIAGRAM (5 of 5)**

**AUDIO FILTER**



NOTES: UNLESS OTHERWISE SPECIFIED

1. FOR ASSEMBLY SEE 755002C0475.
2. CAPACITOR VALUES ARE IN MICROFARADS PLUS OR MINUS 10%, 50V.
3. PARTIAL REFERENCE DESIGNATIONS ARE SHOWN. FOR COMPLETE DESIGNATION, PREFIX WITH UNIT NUMBER OR SUBASSEMBLY DESIGNATION.
4. FOR TEST SPECIFICATION SEE 755002C0477.

  
**ATTENTION**  
**STATIC SENSITIVE**  
**DEVICE**  
**HANDLING**  
**PRECAUTIONS REQUIRED**

755002C0476

Figure 6-17. EFP Schematic Diagram (Sheet 5)

**SYNTHESIZER SCHEMATIC DIAGRAM (1 of 5)**

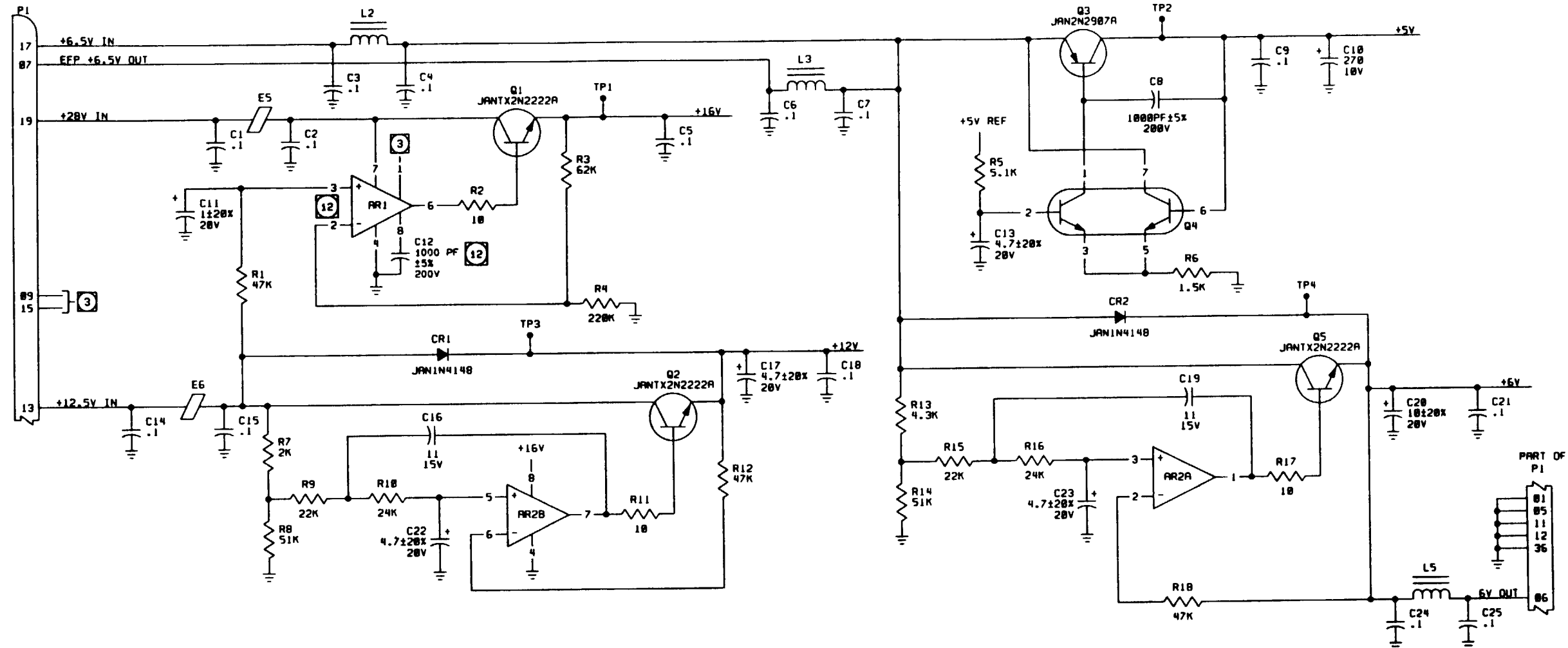

**NOTES: UNLESS OTHERWISE SPECIFIED.**

1. FOR ASSEMBLY SEE 755002C0320.
2. A SQUARE SYMBOL WITH SHADED CORNER(S) AND A NUMBER ENCLOSED INDICATES THE SHEET AND QUADRANT FOR THE ASSOCIATED CONNECTION(S).
3. TERMINALS SHOWN WITHOUT CONNECTION(S) ARE NOT USED.
4. A CIRCLE WITHIN A SQUARE SYMBOL MEANS: SEE NOTE NUMBER INDICATED.
5. RESISTANCE VALUES ARE IN OHMS PLUS OR MINUS 2%, 1/8W.
6. CAPACITANCE VALUES ARE IN MICROFARADS PLUS OR MINUS 10%, 50V.
7. PARTIAL REFERENCE DESIGNATIONS ARE SHOWN. FOR COMPLETE DESIGNATION, PREFIX WITH UNIT NUMBER OR SUBASSEMBLY DESIGNATION.
8. ALL COILS ARE 10 TURNS AVG NO. 30 ON 3E2A CORE.
9. WHEN SIGNALS WITH WIDE DISTRIBUTION (SUCH AS CLOCK AND SOFT VCC) ORIGINATE ON SHEET 1, SYMBOLS FOR THE ASSOCIATED CONNECTIONS ARE NOT SHOWN.
10. FOR TEST SPECIFICATION SEE 755002C0323.
11. FOR EXTERNAL TCXO SIGNAL CONNECTION, REMOVE JUMPERS BETWEEN E1 AND E2 AND E4 AND E3, THEN CONNECT E2 AND E3 WITH A JUMPER.
12. WHEN REPLACING AR1 OR C12, ENSURE C12 IS 1000 PF.

  
**ATTENTION**  
 STATIC SENSITIVE  
 DEVICE  
 HANDLING  
 PRECAUTIONS REQUIRED

755002C0321

Figure 6-18 Synthesizer Schematic Diagram (Sheet 1)

**SYNTHESIZER SCHEMATIC DIAGRAM (2 of 5)**

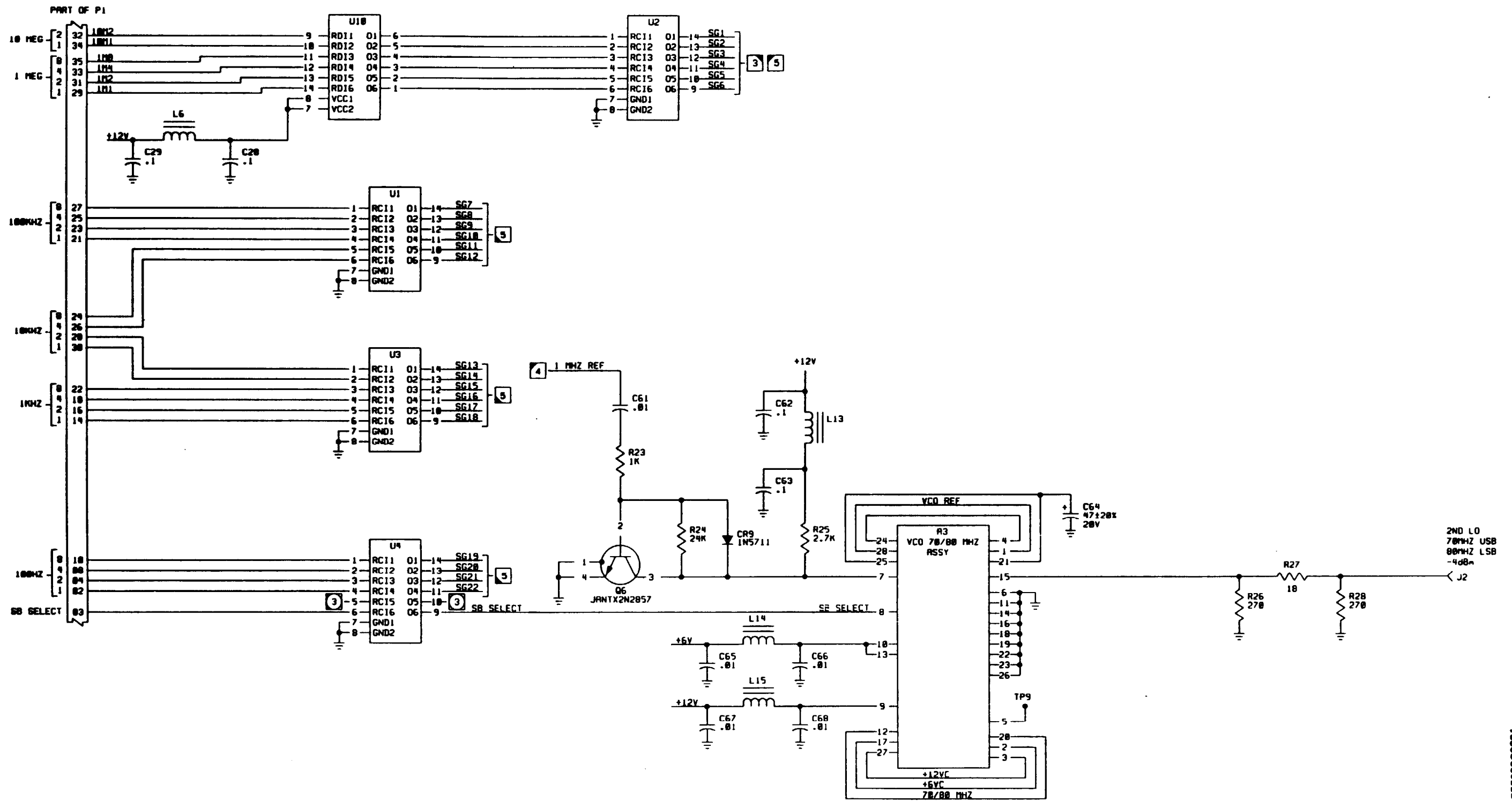

Figure 6-18 Synthesizer Schematic Diagram (Sheet 2)

**SYNTHESIZER SCHEMATIC DIAGRAM (3 of 5)**

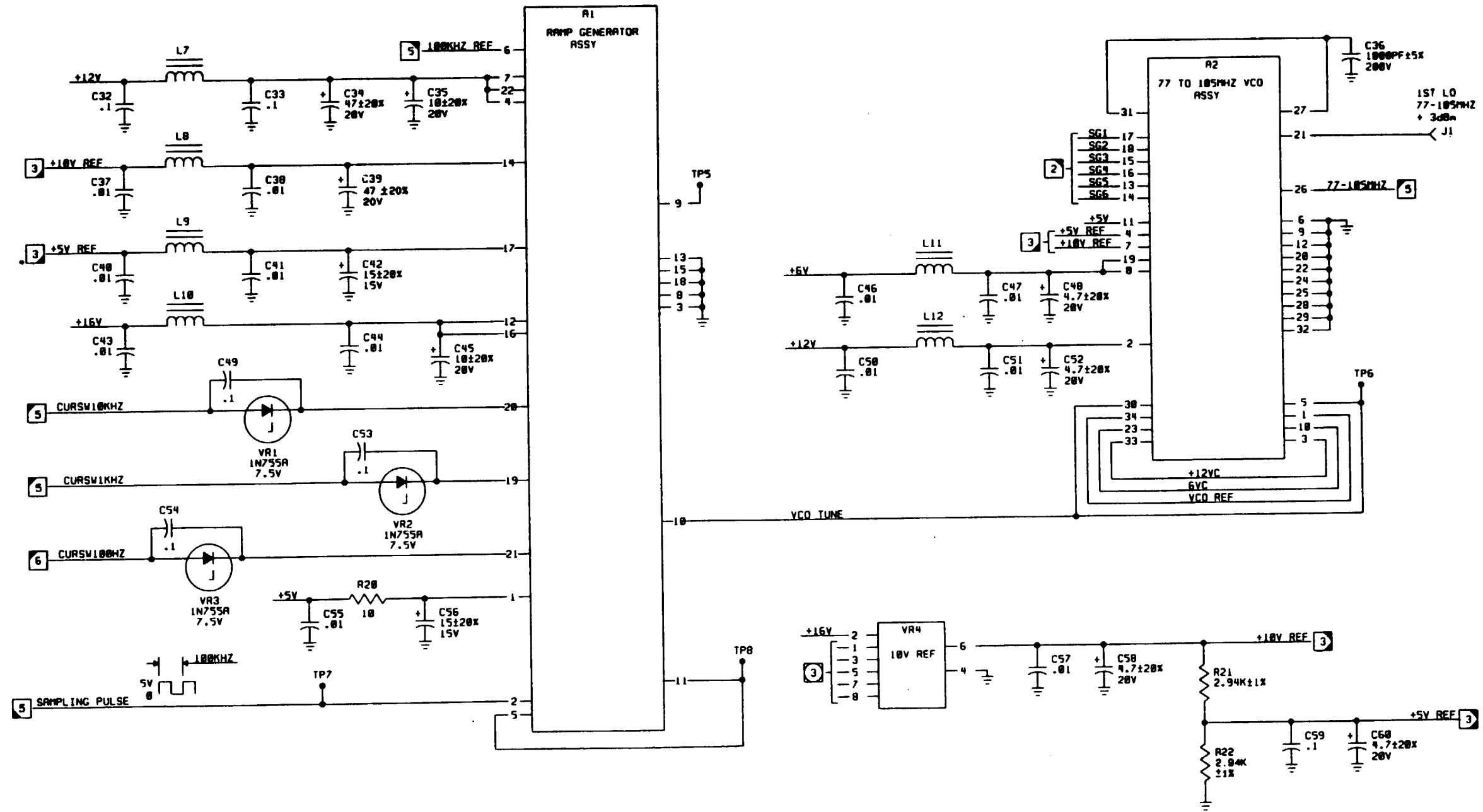

Figure 6-18. Synthesizer Schematic Diagram (Sheet 3)

**SYNTHESIZER SCHEMATIC DIAGRAM (4 of 5)**

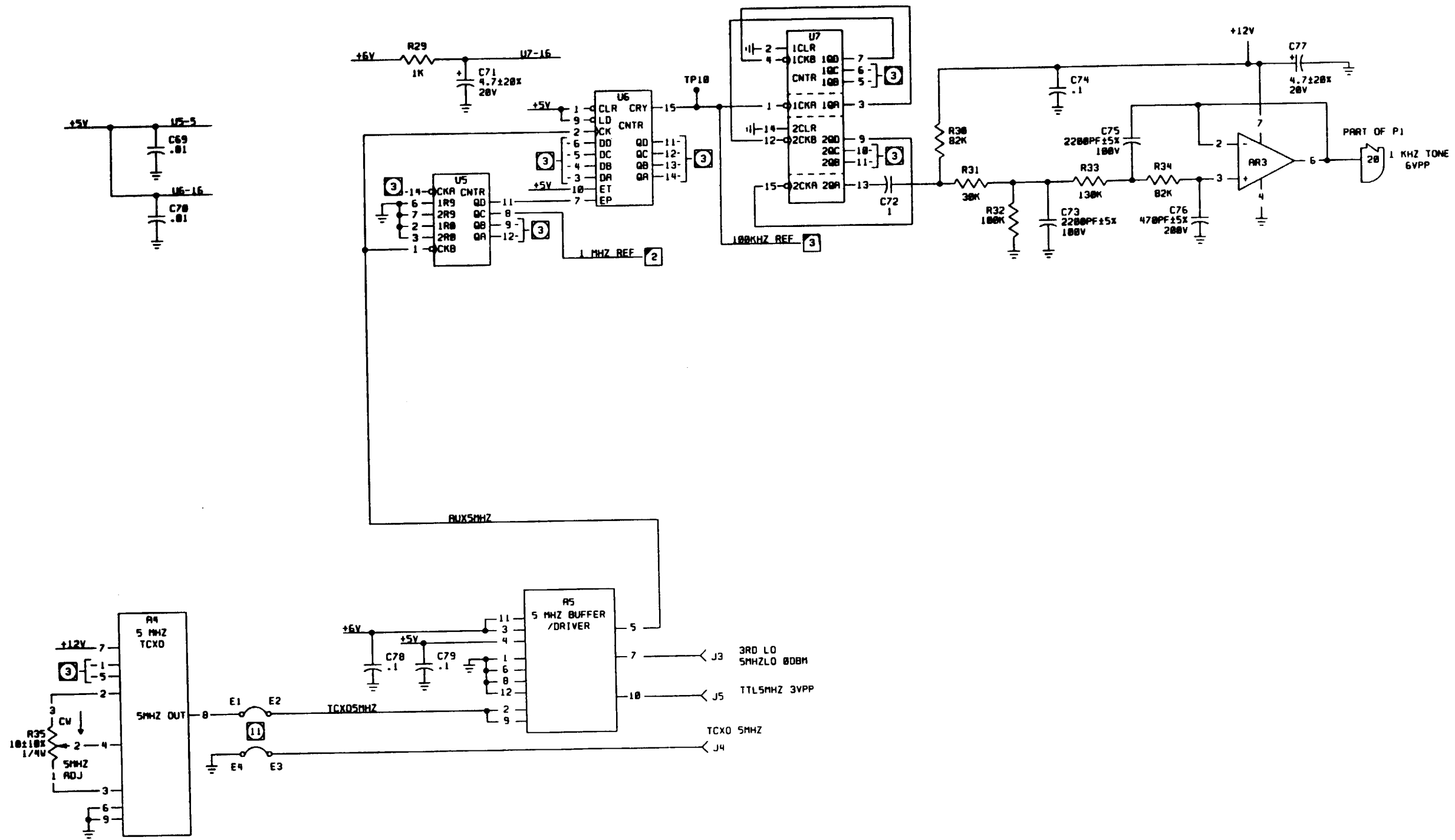
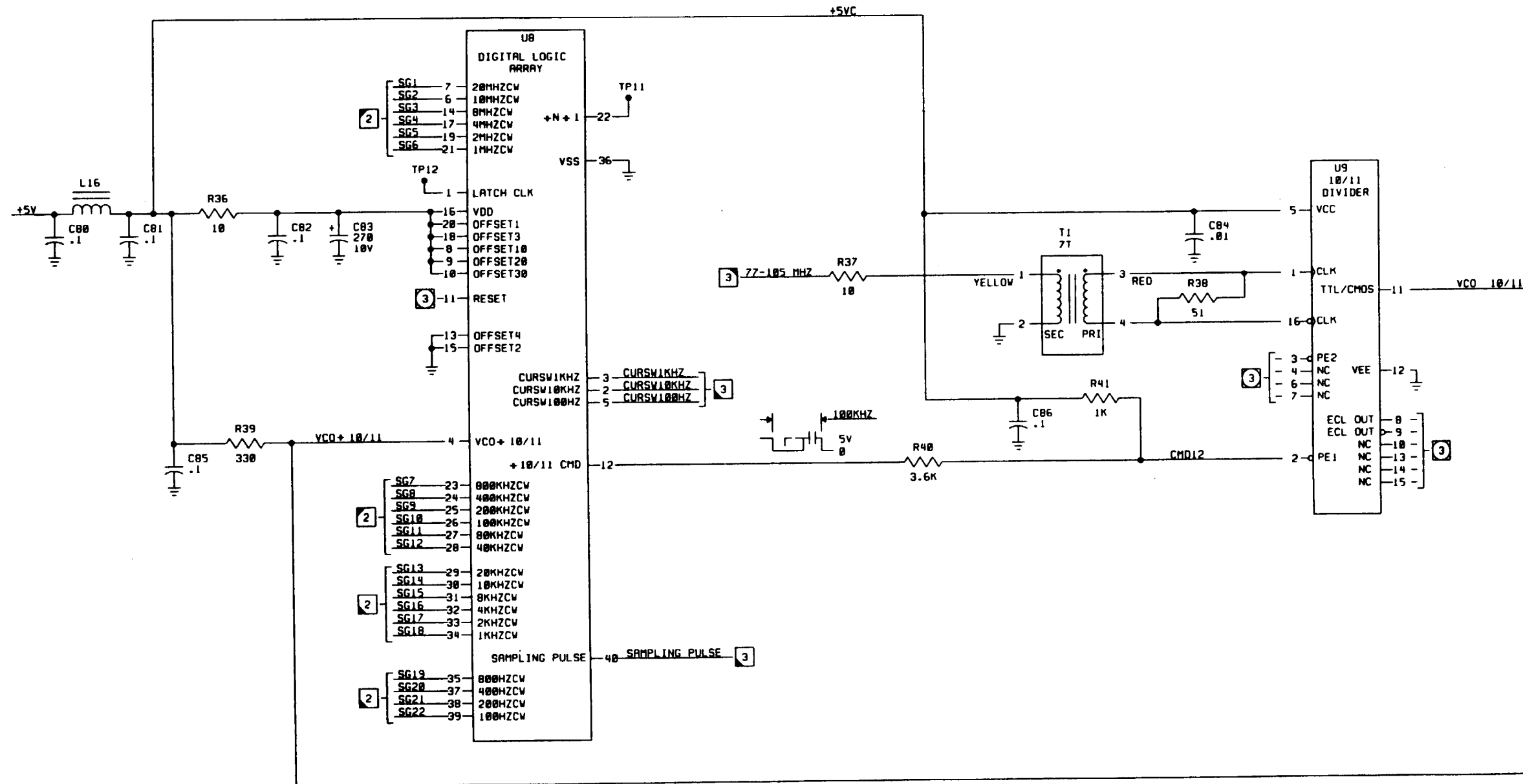

Figure 6-18. Synthesizer Schematic Diagram (Sheet 4)

755002C0321

**SYNTHESIZER SCHEMATIC DIAGRAM (5 of 5)**



755002C0321

Figure 6-18. Synthesizer Schematic Diagram (Sheet 5)

**RAMP GENERATOR SCHEMATIC DIAGRAM (1 of 2)**

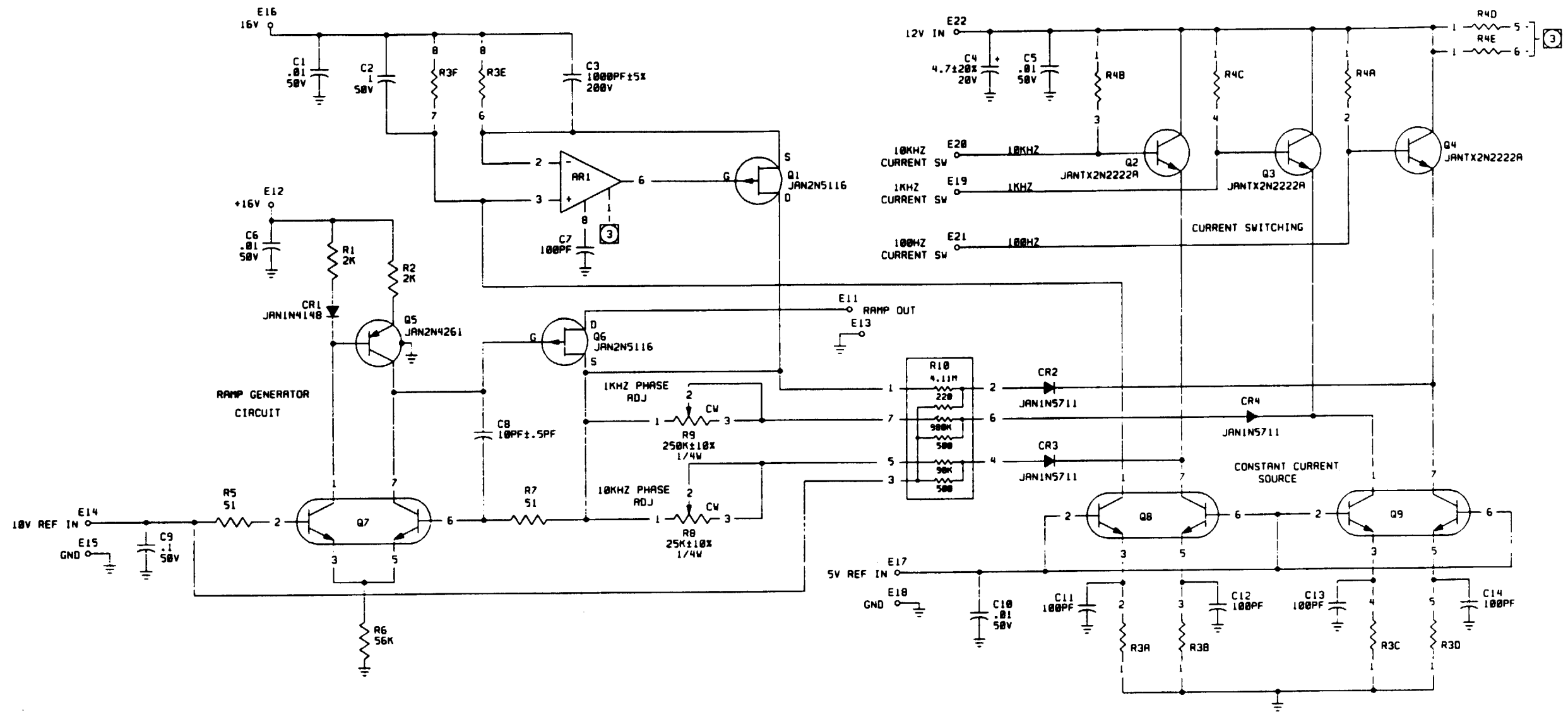

NOTES: UNLESS OTHERWISE SPECIFIED.

1. FOR ASSEMBLY SEE 755002C0394.
2. A CIRCLE WITHIN A SQUARE SYMBOL MEANS: SEE NOTE NUMBER INDICATED.
3. TERMINALS SHOWN WITHOUT CONNECTION(S) ARE NOT USED.
4. RESISTANCE VALUES ARE IN OHMS PLUS OR MINUS 2%, 1/8W.
5. CAPACITANCE VALUES ARE IN MICROFARADS PLUS OR MINUS 10%, 100V.
6. PARTIAL REFERENCE DESIGNATION ARE SHOWN. FOR COMPLETE DESIGNATION, PREFIX WITH UNIT NUMBER OR SUBASSEMBLY DESIGNATION.
7. FOR TEST SPECIFICATION SEE 755002C0396.
8. CR5A THROUGH CR5D ARE A QUAD MATCHED DIODE SET, PART NO. 755002C7036-1.

MODULE IDENTIFICATION				
REFERENCE DESIGNATION	TYPE	+16V PIN	+5V PIN	GND PIN
AR1	LM108H	7	-	4
AR2	LF156H	7	-	4
R3	RES NTWK	-	-	-
R4	RES NTWK	-	-	-
U1	54HC08	-	14	7

REFERENCE DESIGNATION	
HIGHEST NO. USED	NOT USED
AR2	
C2B	
CRB	CR6, CR7, CR8
E22	
L2	
Q11	
R20	
Y2	
U1	

**ATTENTION**  
 STATIC SENSITIVE DEVICE  
 HANDLING PRECAUTIONS REQUIRED

755002C0395 SH 1

Figure 6-19. Ramp Generator Schematic Diagram (Sheet 1)



**RAMP GENERATOR SCHEMATIC DIAGRAM (2 of 2)**

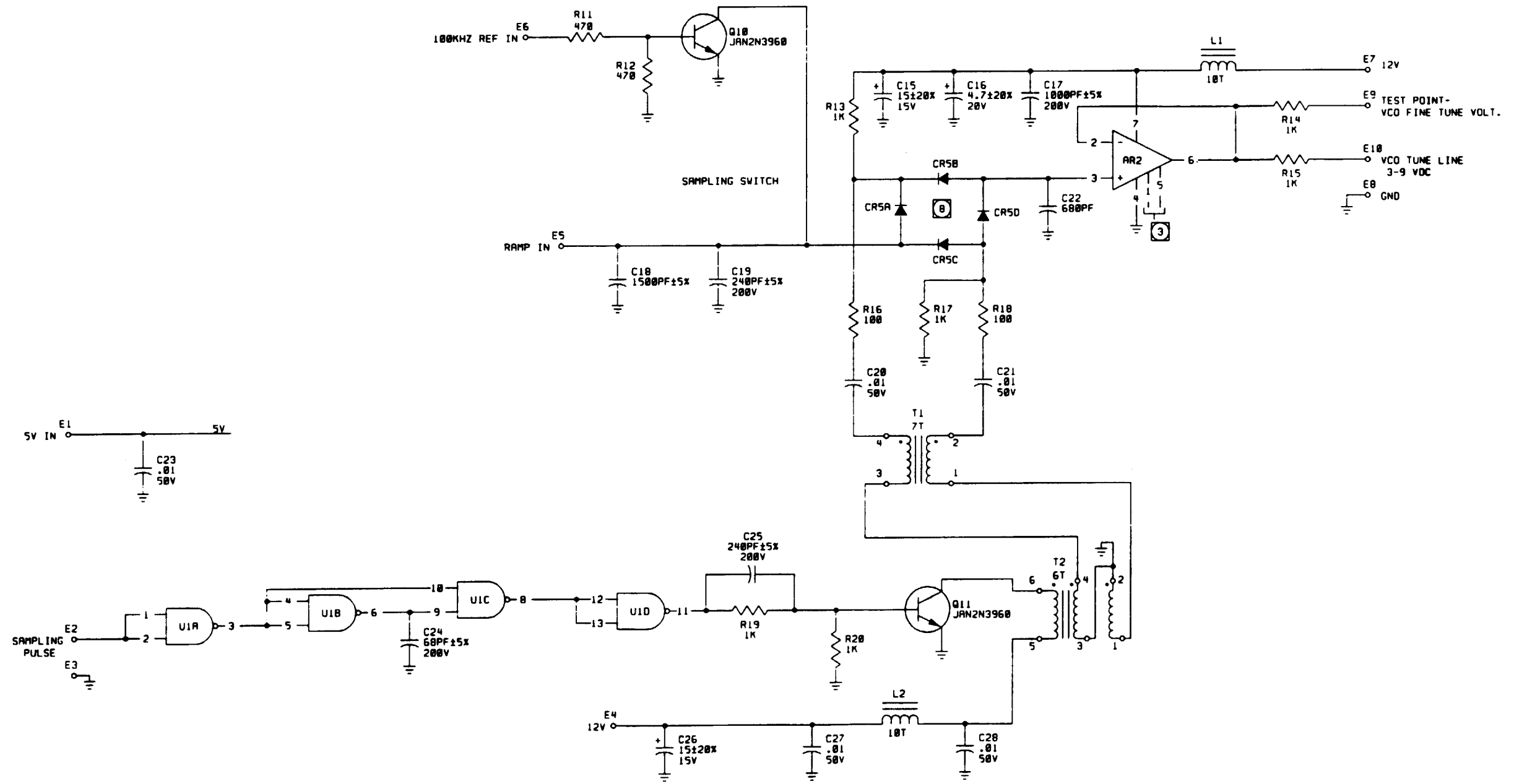
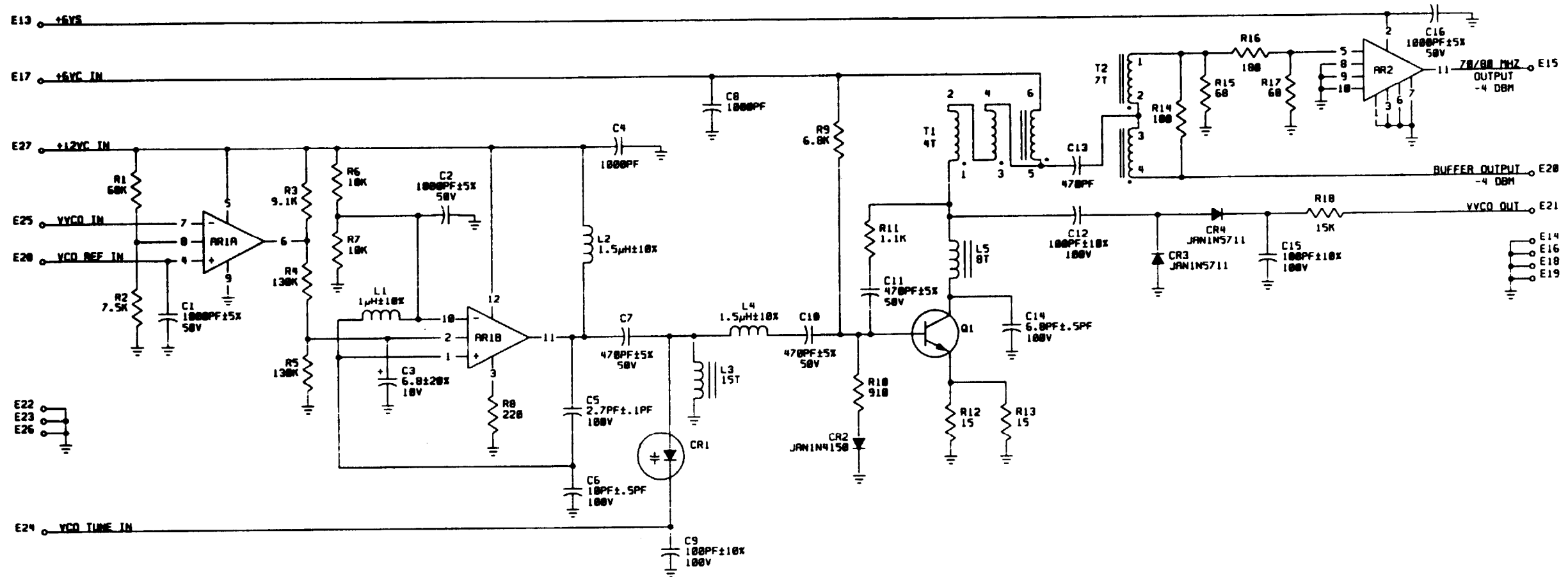

Figure 6-19. Ramp Generator Schematic Diagram (Sheet 2)

**70/80 MHZ VOLTAGE-CONTROLLED OSCILLATOR (VCO) SCHEMATIC DIAGRAM (1 of 2)**



NOTES: UNLESS OTHERWISE SPECIFIED.

1. FOR ASSEMBLY SEE 755002C0365.
2. TERMINALS SHOWN WITHOUT CONNECTION(S) ARE NOT USED.
3. A CIRCLE WITHIN A SQUARE SYMBOL MEANS: SEE NOTE NUMBER INDICATED.
4. RESISTANCE VALUES ARE IN OHMS PLUS OR MINUS 2%, 1/8W.
5. CAPACITANCE VALUES ARE IN MICROFARADS PLUS OR MINUS 5%, 200V.
6. PARTIAL REFERENCE DESIGNATIONS ARE SHOWN. FOR COMPLETE DESIGNATION, PREFIX WITH UNIT NUMBER OR SUBASSEMBLY DESIGNATION.
7. FOR TEST SPECIFICATION SEE 755002C0367.

MODULE IDENTIFICATION				
REFERENCE DESIGNATION	TYPE	+6V PIN	+12V PIN	GND PIN
AR1	CA3049	-	5, 12	-
AR2	HA4281	2	-	4, 12
AR3	LF156H	-	7	4
U1	SP8668	2	-	5
U2	PLL SYNTHESIZER	-	5	-

REFERENCE DESIGNATION	
HIGHEST NO. USED	NUMBERS NOT USED
AR3	
C27	
CR7	
E28	
L6	
Q3	
R48	
T3	
U2	

  
**ATTENTION**  
 STATIC SENSITIVE  
 DEVICE  
 HANDLING  
 PRECAUTIONS REQUIRED

755002C0366 SH 1

Figure 6-20. 70/80 MHz Voltage-Controlled Oscillator (VCO) Schematic Diagram (Sheet 1)

70/80 MHz VOLTAGE-CONTROLLED OSCILLATOR (VCO) SCHEMATIC DIAGRAM (2 of 2)

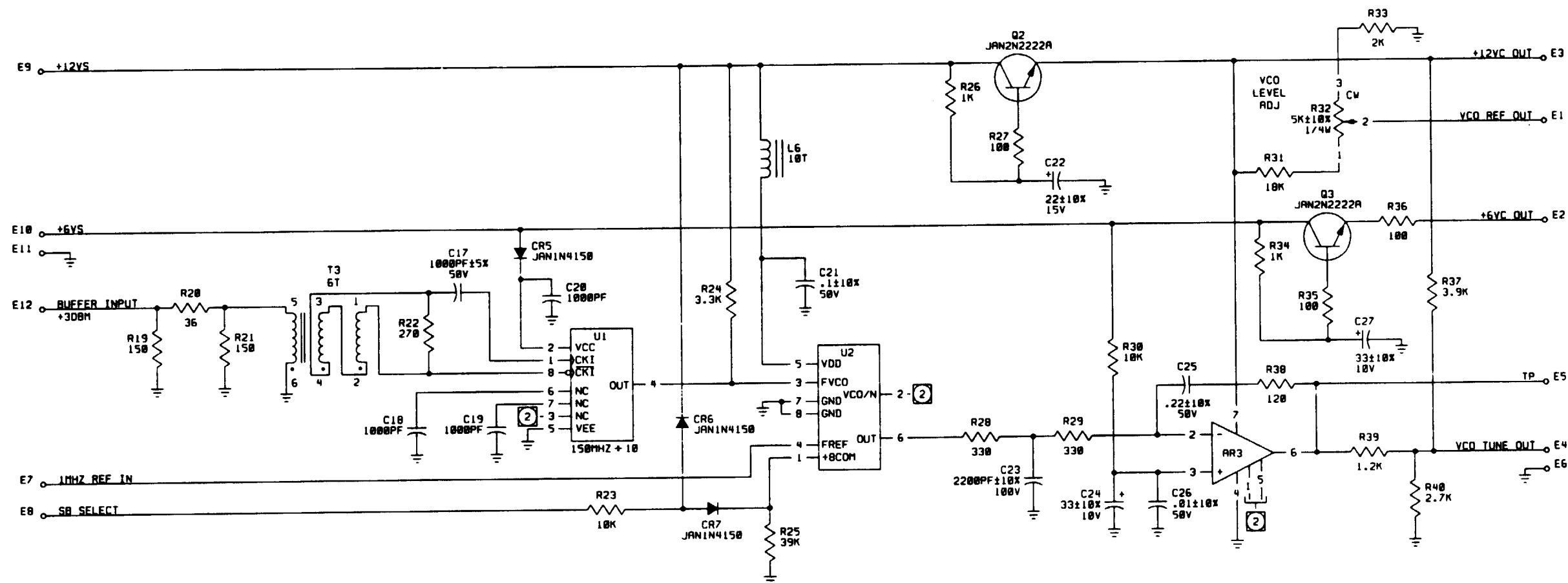
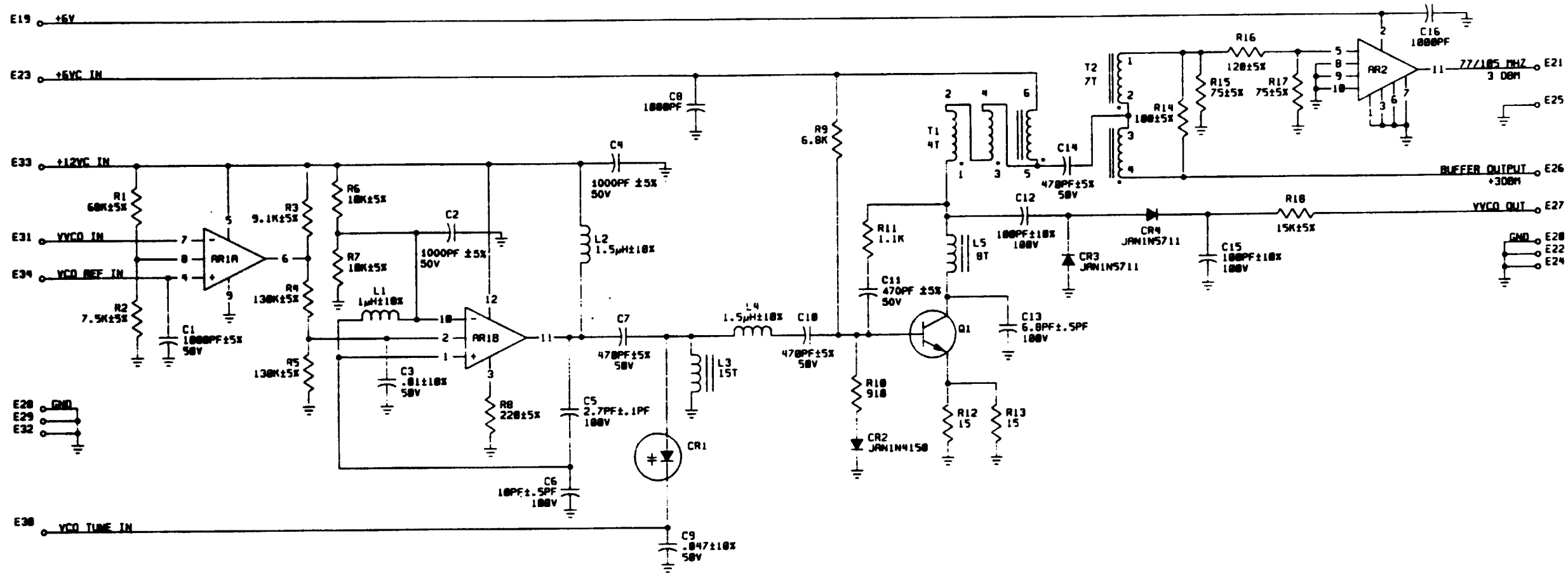

Figure 6-20. 70/80 MHz Voltage-Controlled Oscillator (VCO) Schematic Diagram (Sheet 2)

**77-105 MHZ VOLTAGE-CONTROLLED OSCILLATOR (VCO) SCHEMATIC DIAGRAM (1 of 2)**



NOTES: UNLESS OTHERWISE SPECIFIED.

1. FOR ASSEMBLY SEE 755002C0330.
2. TERMINALS SHOWN WITHOUT CONNECTION ARE NOT USED.
3. A CIRCLE WITHIN A SQUARE SYMBOL MEANS: SEE NOTE NUMBER INDICATED.
4. RESISTANCE VALUES ARE IN OHMS PLUS OR MINUS 2X.1/8V.
5. CAPACITANCE VALUES ARE IN MICROFARADS PLUS OR MINUS 5X.200V.
6. PARTIAL REFERENCE DESIGNATION ARE SHOWN. FOR COMPLETE DESIGNATION, PREFIX WITH UNIT NUMBER OR SUBASSEMBLY DESIGNATION.
7. FOR TEST SPECIFICATION SEE 755002C0332.

MODULE IDENTIFICATION			
REFERENCE DESIGNATION	TYPE	+VCC PIN	GND PIN
AR1	CA3049	5, 12	9, 3
AR2	AM4201	2	4, 12
AR3	OP27BJ	7	u
R20	RES NTWK ±1%, .04W	-	-
U1	54HC05	14	7

REFERENCE DESIGNATION	
HIGHEST NO. USED	NUMBERS NOT USED
AR3	
C23	
CR4	
E34	
L6	
Q3	
R34	
T2	
U1	

  
**ATTENTION**  
 STATIC SENSITIVE  
 DEVICE  
 HANDLING  
 PRECAUTIONS REQUIRED

755002C0331 SH 1

Figure 6-21. 77-105 MHz Voltage-Controlled Oscillator (VCO) Schematic Diagram (Sheet 1)

77-105 MHZ VOLTAGE-CONTROLLED OSCILLATOR (VCO) SCHEMATIC DIAGRAM (2 of 2)

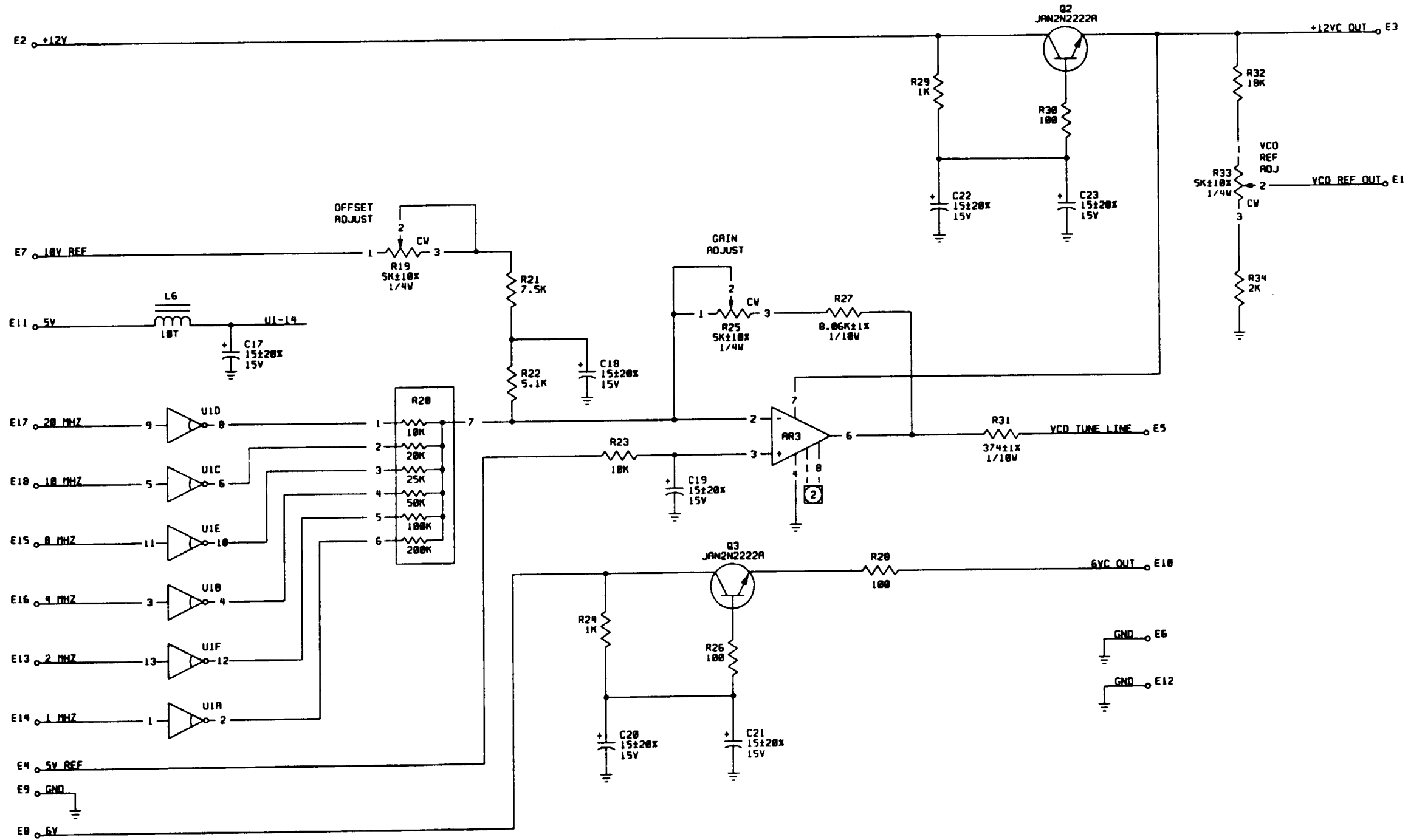
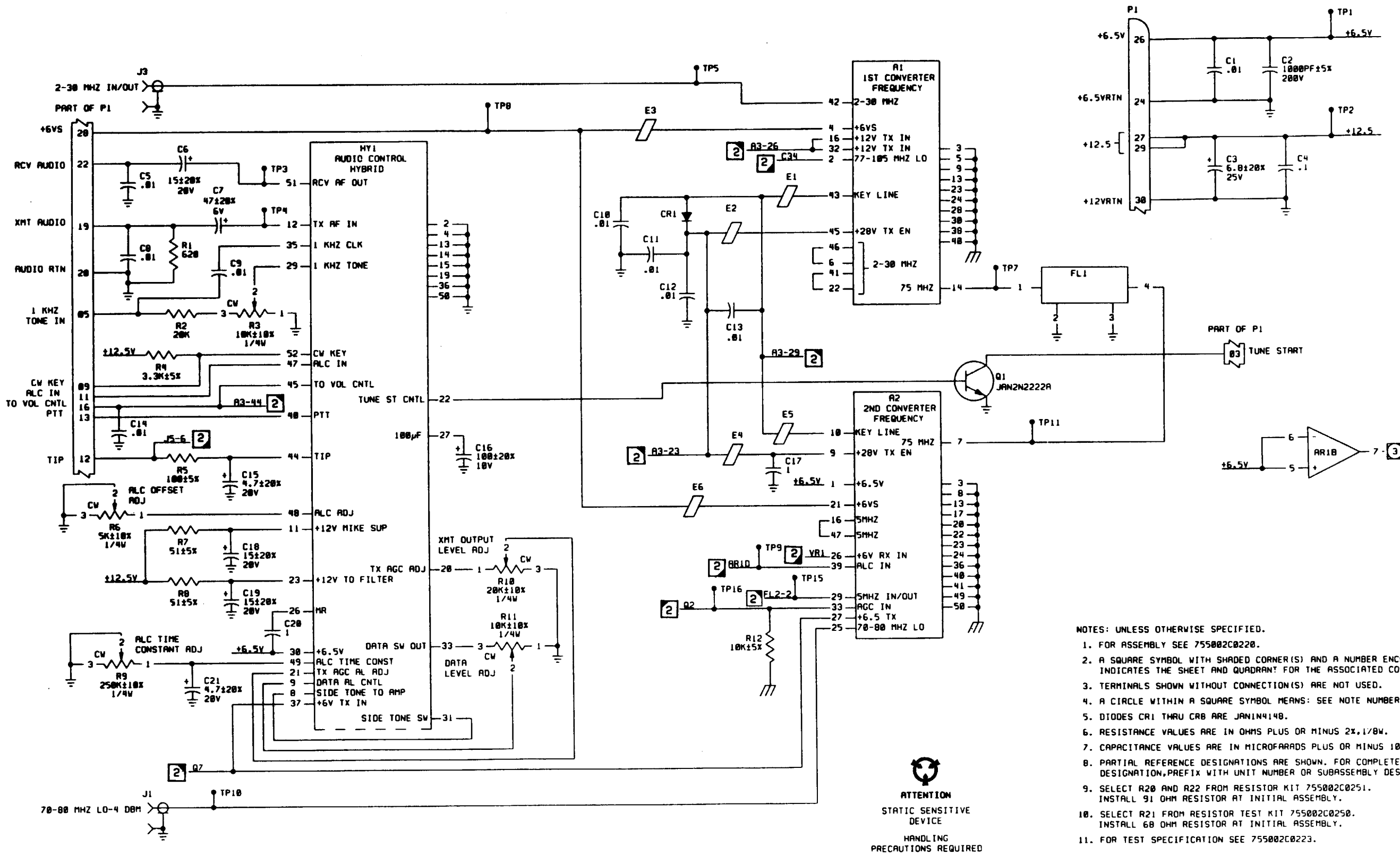

Figure 6-21. 77-105 MHz Voltage-Controlled Oscillator (VCO) Schematic Diagram (Sheet 2)

**MODULATOR/DEMODULATOR SCHEMATIC DIAGRAM (1 of 2)**



- NOTES: UNLESS OTHERWISE SPECIFIED.
1. FOR ASSEMBLY SEE 755002C0220.
  2. A SQUARE SYMBOL WITH SHADED CORNER(S) AND A NUMBER ENCLOSED INDICATES THE SHEET AND QUADRANT FOR THE ASSOCIATED CONNECTION(S).
  3. TERMINALS SHOWN WITHOUT CONNECTION(S) ARE NOT USED.
  4. A CIRCLE WITHIN A SQUARE SYMBOL MEANS: SEE NOTE NUMBER INDICATED.
  5. DIODES CR1 THRU CR8 ARE JANIN4148.
  6. RESISTANCE VALUES ARE IN OHMS PLUS OR MINUS 2%, 1/4W.
  7. CAPACITANCE VALUES ARE IN MICROFARADS PLUS OR MINUS 10%, 50V.
  8. PARTIAL REFERENCE DESIGNATIONS ARE SHOWN. FOR COMPLETE DESIGNATION, PREFIX WITH UNIT NUMBER OR SUBASSEMBLY DESIGNATION.
  9. SELECT R20 AND R22 FROM RESISTOR KIT 755002C0251. INSTALL 91 OHM RESISTOR AT INITIAL ASSEMBLY.
  10. SELECT R21 FROM RESISTOR TEST KIT 755002C0250. INSTALL 68 OHM RESISTOR AT INITIAL ASSEMBLY.
  11. FOR TEST SPECIFICATION SEE 755002C0223.

**ATTENTION**  
 STATIC SENSITIVE  
 DEVICE  
 HANDLING  
 PRECAUTIONS REQUIRED

Figure 6-22. Modulator/Demodulator Schematic Diagram (Sheet 1)

755002C0221

**MODULATOR/DEMODULATOR SCHEMATIC DIAGRAM (2 of 2)**

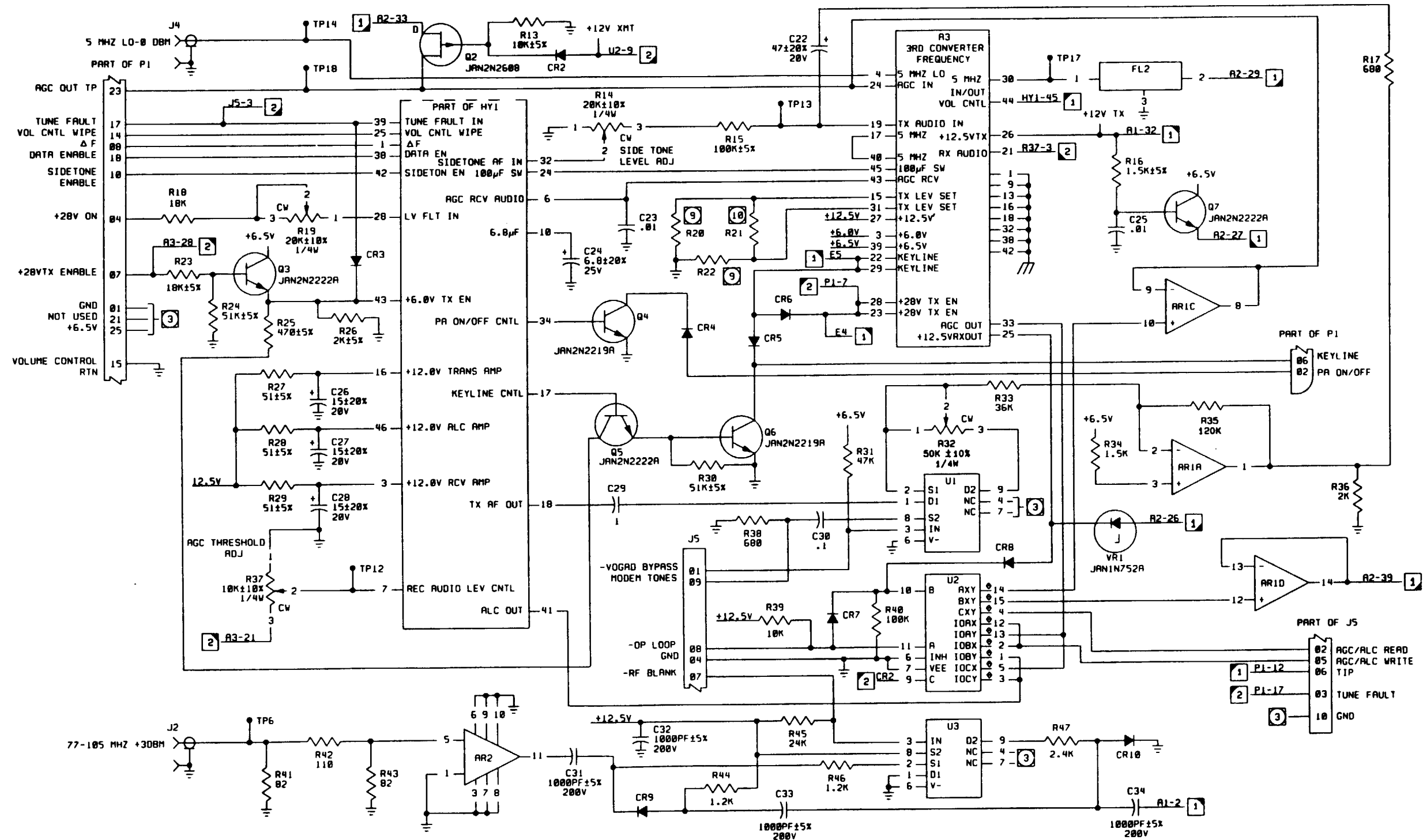
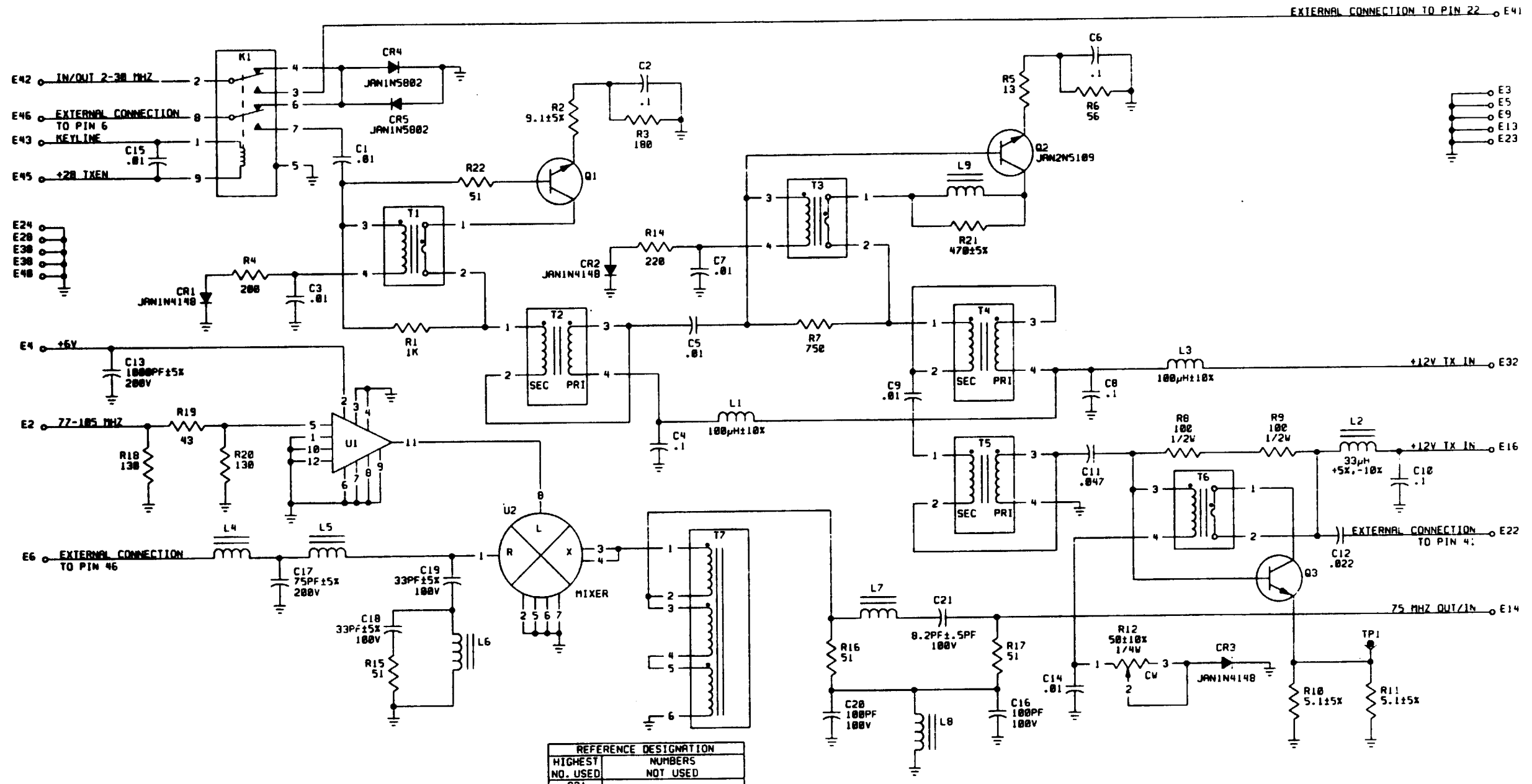

Figure 6-22. Modulator/Demodulator Schematic Diagram (Sheet 2)

755002C0221

**FIRST FREQUENCY CONVERTER SCHEMATIC DIAGRAM**



- NOTES: UNLESS OTHERWISE SPECIFIED.
1. FOR ASSEMBLY SEE 755002C0230.
  2. RESISTANCE VALUES ARE IN OHMS LUS OR MINUS 2%, 1/8W.
  3. CAPACITANCE VALUES ARE IN MICROFARADS PLUS OR MINUS 10%, 50V.
  4. PARTIAL REFERENCE DESIGNATIONS ARE SHOWN. FOR COMPLETE DESIGNATION, PREFIX WITH UNIT NUMBER OR SUBASSEMBLY DESIGNATION.
  5. FOR TEST SPECIFICATION SEE 755002A0232.

REFERENCE DESIGNATION	HIGHEST NO. USED	NUMBERS NOT USED
C21		
CR5		
E46	E1, E7, E8, E10-E12, E15, E17-E21, E25-E27, E29, E31, E33-E37, E39, E44	
K1		
L9		
Q3		
R22	R13	
T7		
TP1		
U2		

**ATTENTION**  
 STATIC SENSITIVE DEVICE  
 HANDLING PRECAUTIONS REQUIRED

755002C0231

Figure 6-23. First Frequency Converter Schematic Diagram



**SECOND FREQUENCY CONVERTER SCHEMATIC DIAGRAM**

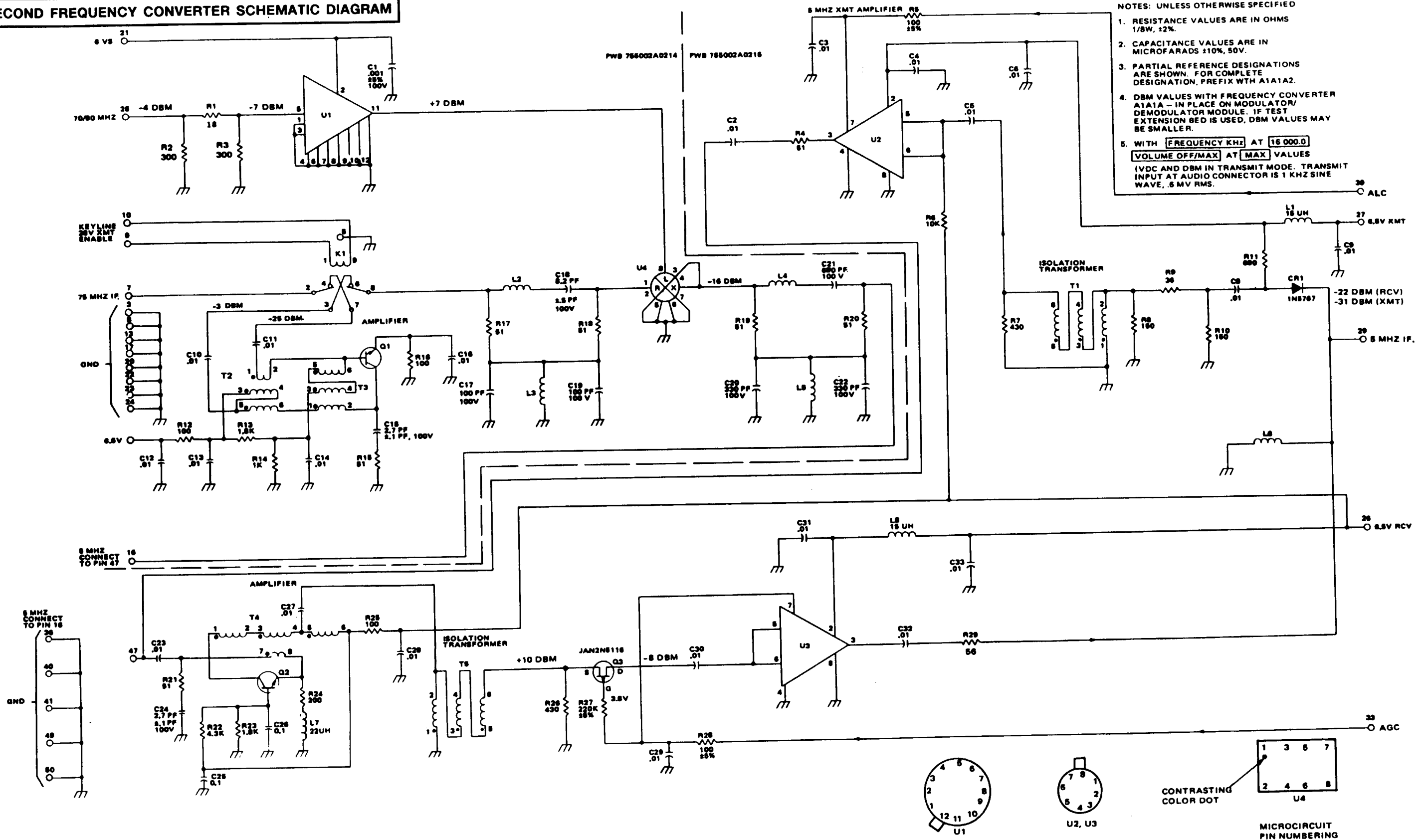
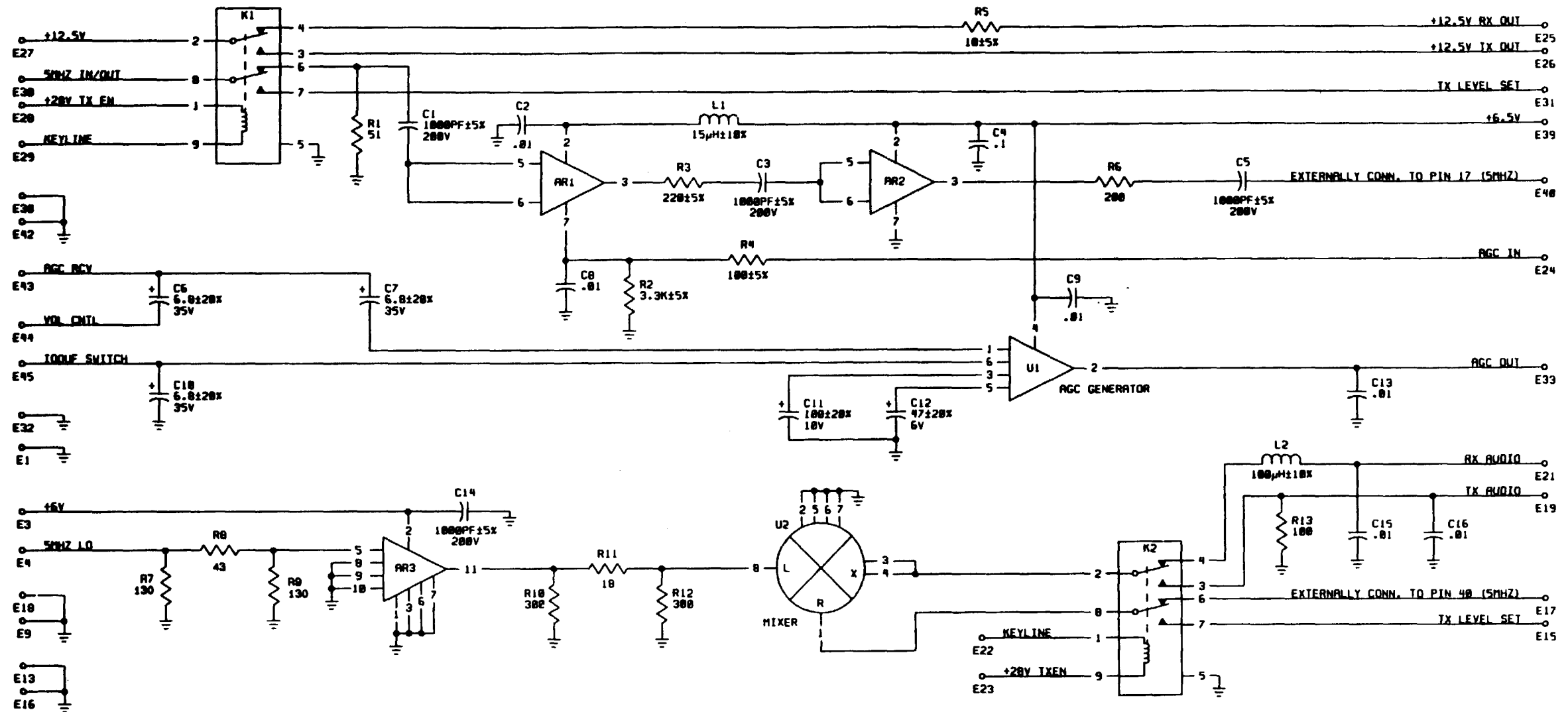

Figure 6-24. Second Frequency Converter Schematic Diagram

55002A0238

**THIRD FREQUENCY CONVERTER SCHEMATIC DIAGRAM**



NOTES: UNLESS OTHERWISE SPECIFIED.

1. FOR ASSEMBLY SEE 755002C0243.
2. RESISTANCE VALUES ARE IN OHMS PLUS OR MINUS 2%, 1/8W.
3. CAPACITANCE VALUES ARE IN MICROFARADS PLUS OR MINUS 10%, 50V.
4. PARTIAL REFERENCE DESIGNATIONS ARE SHOWN. FOR COMPLETE DESIGNATION, PREFIX WITH UNIT NUMBER OR SUBASSEMBLY DESIGNATION.
5. FOR TEST SPECIFICATION SEE 755002C0245.

  
**ATTENTION**  
 STATIC SENSITIVE  
 DEVICE  
 HANDLING  
 PRECAUTIONS REQUIRED

75002C0244

Figure 6-25. Third Frequency Converter Schematic Diagram

**HARMONIC FILTER SCHEMATIC DIAGRAM**

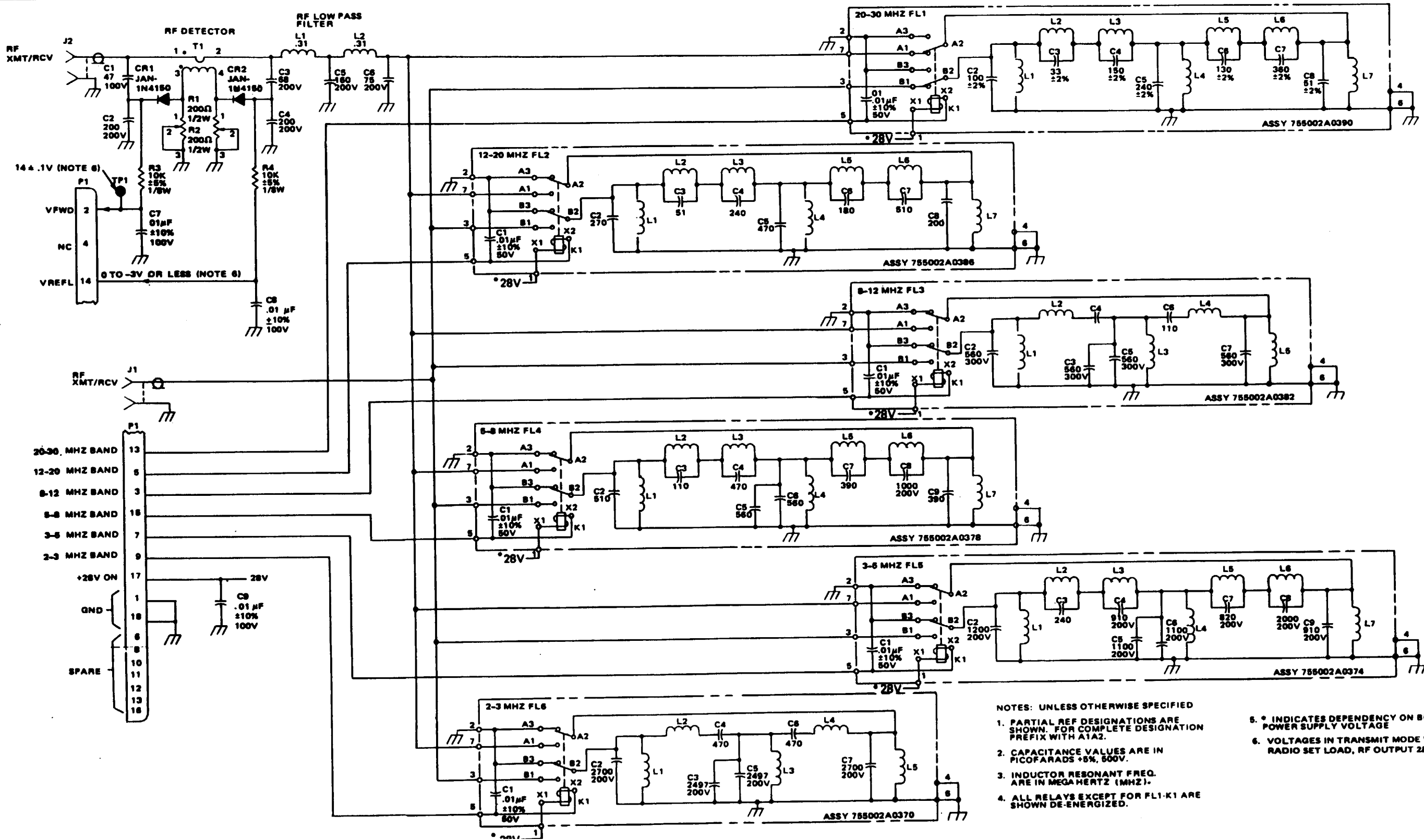

- NOTES: UNLESS OTHERWISE SPECIFIED
1. PARTIAL REF DESIGNATIONS ARE SHOWN. FOR COMPLETE DESIGNATION PREFIX WITH A1A2.
  2. CAPACITANCE VALUES ARE IN PICOFARADS ±5%, 500V.
  3. INDUCTOR RESONANT FREQ. ARE IN MEGA HERTZ (MHZ).
  4. ALL RELAYS EXCEPT FOR FL1-K1 ARE SHOWN DE-ENERGIZED.
  5. \* INDICATES DEPENDENCY ON BENCH POWER SUPPLY VOLTAGE
  6. VOLTAGES IN TRANSMIT MODE WITH 50 OHM RADIO SET LOAD, RF OUTPUT 20W.

Figure 6-26. Harmonic Filter Schematic Diagram

755002A0271

**POWER SUPPLY SCHEMATIC DIAGRAM**

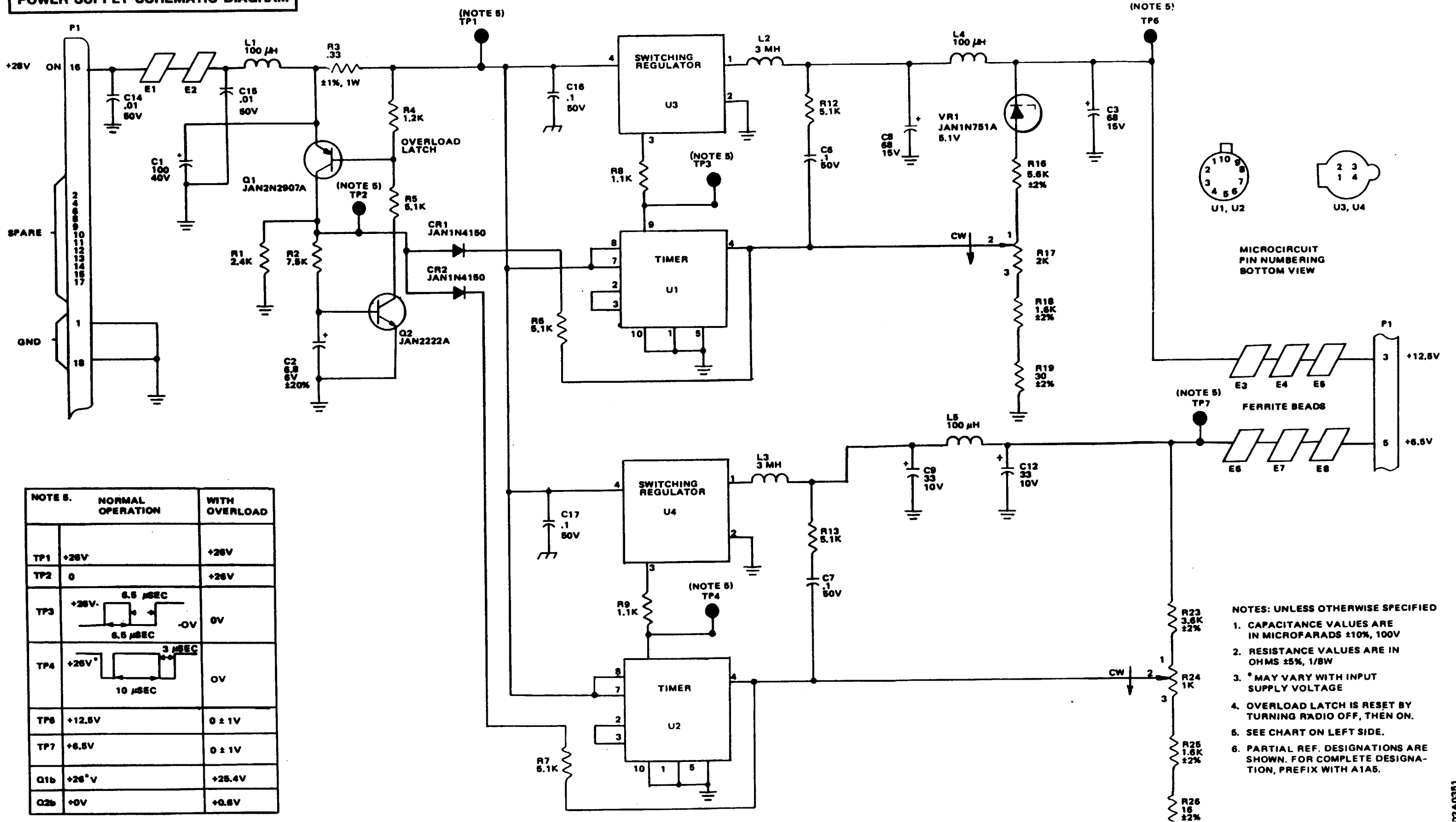

NOTE 5.		NORMAL OPERATION	WITH OVERLOAD
TP1		+28V	+28V
TP2		0	+28V
TP3			0V
TP4			0V
TP6		+12.5V	0 ± 1V
TP7		+6.5V	0 ± 1V
Q1b		+28V	+25.4V
Q2b		+0V	+0.6V

- NOTES: UNLESS OTHERWISE SPECIFIED
1. CAPACITANCE VALUES ARE IN MICROFARADS ±10%, 100V
  2. RESISTANCE VALUES ARE IN OHMS ±5%, 1/8W
  3. \* MAY VARY WITH INPUT SUPPLY VOLTAGE
  4. OVERLOAD LATCH IS RESET BY TURNING RADIO OFF, THEN ON.
  5. SEE CHART ON LEFT SIDE.
  6. PARTIAL REF. DESIGNATIONS ARE SHOWN. FOR COMPLETE DESIGNATION, PREFIX WITH A1A5.

Figure 6-27. Power Supply Schematic Diagram

**MARINE CORPS ONLY**  
**CHAPTER 7**  
**AMPLIFIER/COUPLER DEPOT MAINTENANCE**

**Section I. AMPLIFIER/COUPLER FAULT ISOLATION**

	Page
General .....	7-1
Power Amplifier Fault Isolation .....	7-1
Special Tools and Test Equipment .....	7-1
Performance Test Setup .....	7-2
Performance Test .....	7-3
Alignment Procedure .....	7-7

	Page
Antenna Tuner Fault Isolation .....	7-8
Special Tools and Test Equipment .....	7-8
Performance Test Setup .....	7-9
Performance Test .....	7-10
Alignment Procedure .....	7-15

**GENERAL**

This section contains information required to enable the technician to locate malfunctions in the components of the amplifier/coupler modules. Fault isolation procedures are provided for the power amplifier and antenna tuner.

**NOTE**

All measurements in the fault isolation and alignment procedures are taken with respect to chassis ground, unless otherwise specified.

**POWER AMPLIFIER FAULT ISOLATION**

The power amplifier fault isolation procedure is divided into the following: special tools and test equipment, performance test setup, performance test, and alignment procedure.

**POWER AMPLIFIER FAULT ISOLATION SPECIAL TOOLS AND TEST EQUIPMENT**

Description	Part Number
Harmonic Filter/Power Amplifier Test Extender Cable	...
Audio Input/Keying Adapter	...
RF Coax Cable	...
Tool Kit, Electronic	TK-105/G
Bench Repair Center	Pace PRC-350C
Maintenance Kit, Printed Circuit	MK-984/A
Radio Set, Test Bed	AN/PRC-104

Description	Part Number
VTVM	
Signal Generator, RF	
Oscilloscope	
Digital Multimeter (DVM, ohmmeter function)	
Attenuator, Step 10-db steps, 0.5 W, 50 ohms	
Dummy Load (50 ohms)	
Wattmeter	
— Power Meter	
— Thermocouple Power Sensor	
Spectrum Analyzer	
— High Resolution IF. Section	
— RF Section	
— Tracking Generator	
— High Impedance Probe	
Power Supply, DC	
Attenuator, Coaxial 20 db, 30 W min, 50 ohms	Narda 765-20

**NOTE**

Refer to page 1-6 for test equipment characteristics.

**POWER AMPLIFIER FAULT ISOLATION PERFORMANCE TEST SETUP**

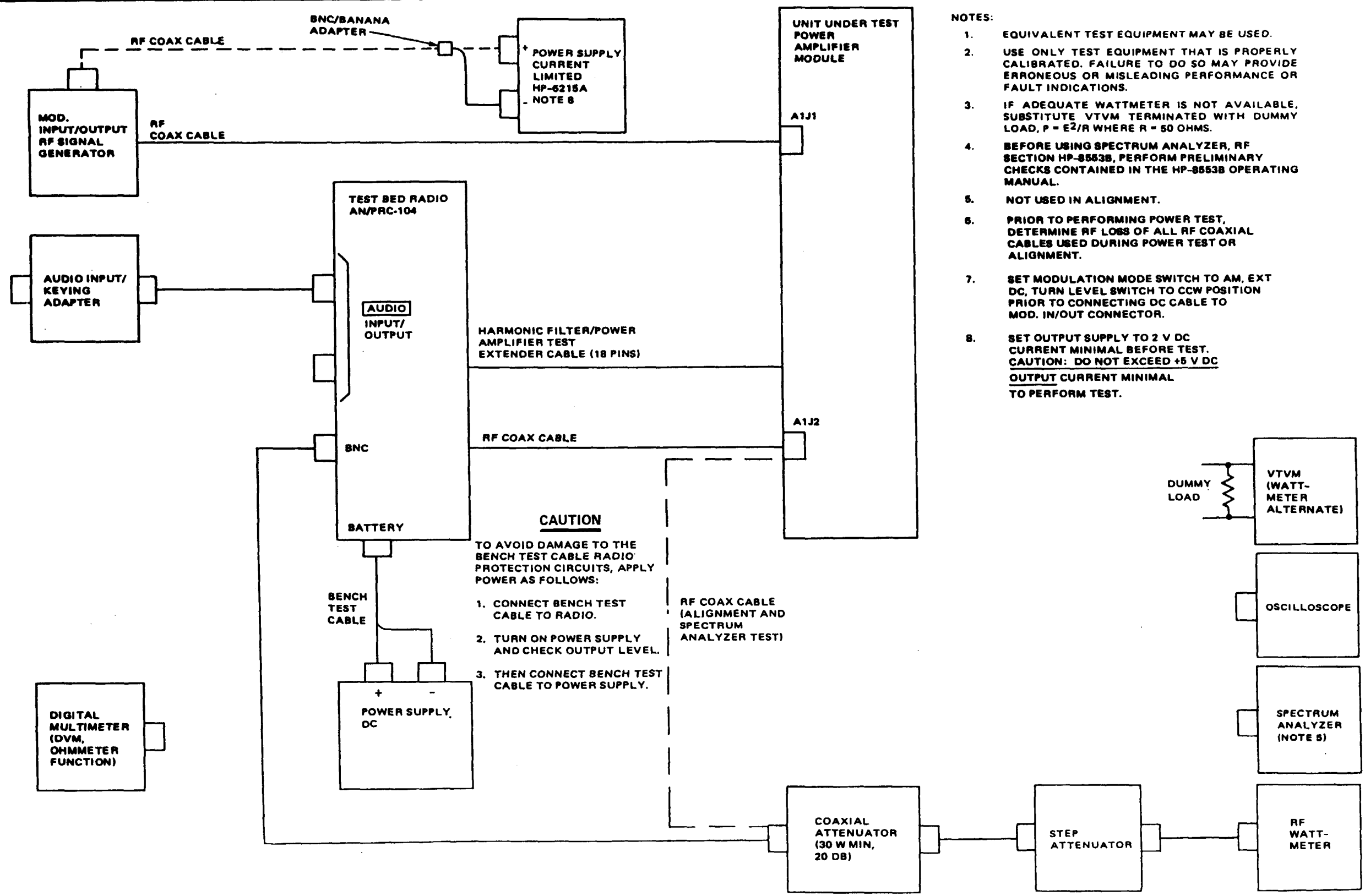

- NOTES:
1. EQUIVALENT TEST EQUIPMENT MAY BE USED.
  2. USE ONLY TEST EQUIPMENT THAT IS PROPERLY CALIBRATED. FAILURE TO DO SO MAY PROVIDE ERRONEOUS OR MISLEADING PERFORMANCE OR FAULT INDICATIONS.
  3. IF ADEQUATE WATTMETER IS NOT AVAILABLE, SUBSTITUTE VTVM TERMINATED WITH DUMMY LOAD,  $P = E^2/R$  WHERE  $R = 50$  OHMS.
  4. BEFORE USING SPECTRUM ANALYZER, RF SECTION HP-8553B, PERFORM PRELIMINARY CHECKS CONTAINED IN THE HP-8553B OPERATING MANUAL.
  5. NOT USED IN ALIGNMENT.
  6. PRIOR TO PERFORMING POWER TEST, DETERMINE RF LOSS OF ALL RF COAXIAL CABLES USED DURING POWER TEST OR ALIGNMENT.
  7. SET MODULATION MODE SWITCH TO AM, EXT DC, TURN LEVEL SWITCH TO CCW POSITION PRIOR TO CONNECTING DC CABLE TO MOD. IN/OUT CONNECTOR.
  8. SET OUTPUT SUPPLY TO 2 V DC CURRENT MINIMAL BEFORE TEST. **CAUTION: DO NOT EXCEED +5 V DC OUTPUT CURRENT MINIMAL TO PERFORM TEST.**

Figure 7-1. Power Amplifier Fault Isolation Performance Test Setup

**POWER AMPLIFIER FAULT ISOLATION PERFORMANCE TEST (1 of 4)**

**NOTES**

1. TP8 voltage should be between 2.8 and 9.8 V peak to peak when frequency is between 2 and 16 MHz. TP8 voltage should be between 10.6 and 36.4 V peak to peak when frequency is between 17 and 30 MHz.
2. A negative voltage (-7.5 V) may be injected at pin 5 of P1 to test AR2-2, Q16 without using rf drive.
3. Unless otherwise specified, all voltage measurements taken with respect to chassis ground.
4. All points of test for this troubleshooting branch on 755002A0668 board.

HARMONICS TOLERANCE:  
 FIRST - 10 DB MIN  
 SECOND - 30 DB MIN  
 THIRD - 30 DB MIN  
 FOURTH - 30 DB MIN  
 FIFTH - 30 DB MIN  
 WITH RESPECT TO CARRIER

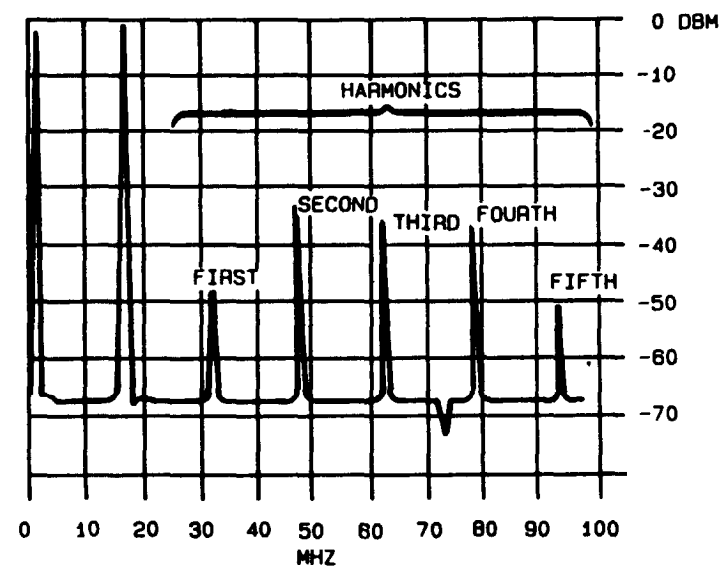

FIGURE A

BANDWIDTH	300 KHZ
SCAN WIDTH	10 MHZ
INPUT ATTENUATOR	40 DB
SCAN TIME DIV	0.5 SEC
LOG. REF LEVEL	+10
LINEAR SENSITIVITY	0
VIDEO FILTER	100 HZ
SCAN MODE	SINGLE
10-DB LOG.	10-DB LOG.
SCAN TRIGGER	AUTO
CENTER FREQUENCY	50 MHZ
SCAN (INNER RED)	PER DIV
RANGE MHZ	0-110
STORAGE	STD
INTENSITY	CENTERED
PERSISTENCE	90 - 180°
TIME	90°

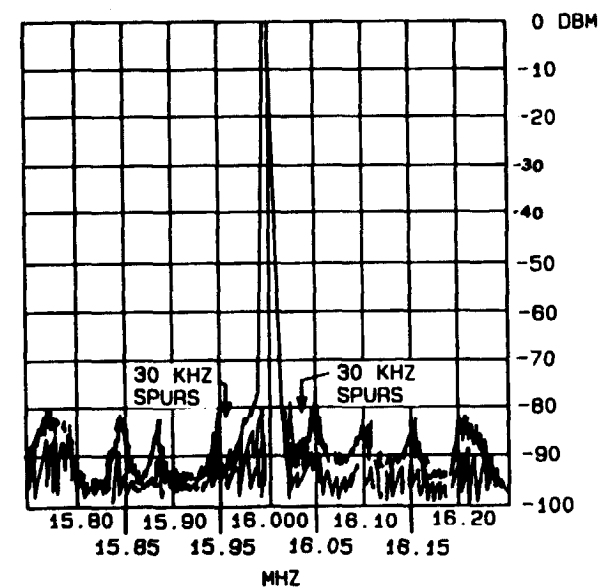
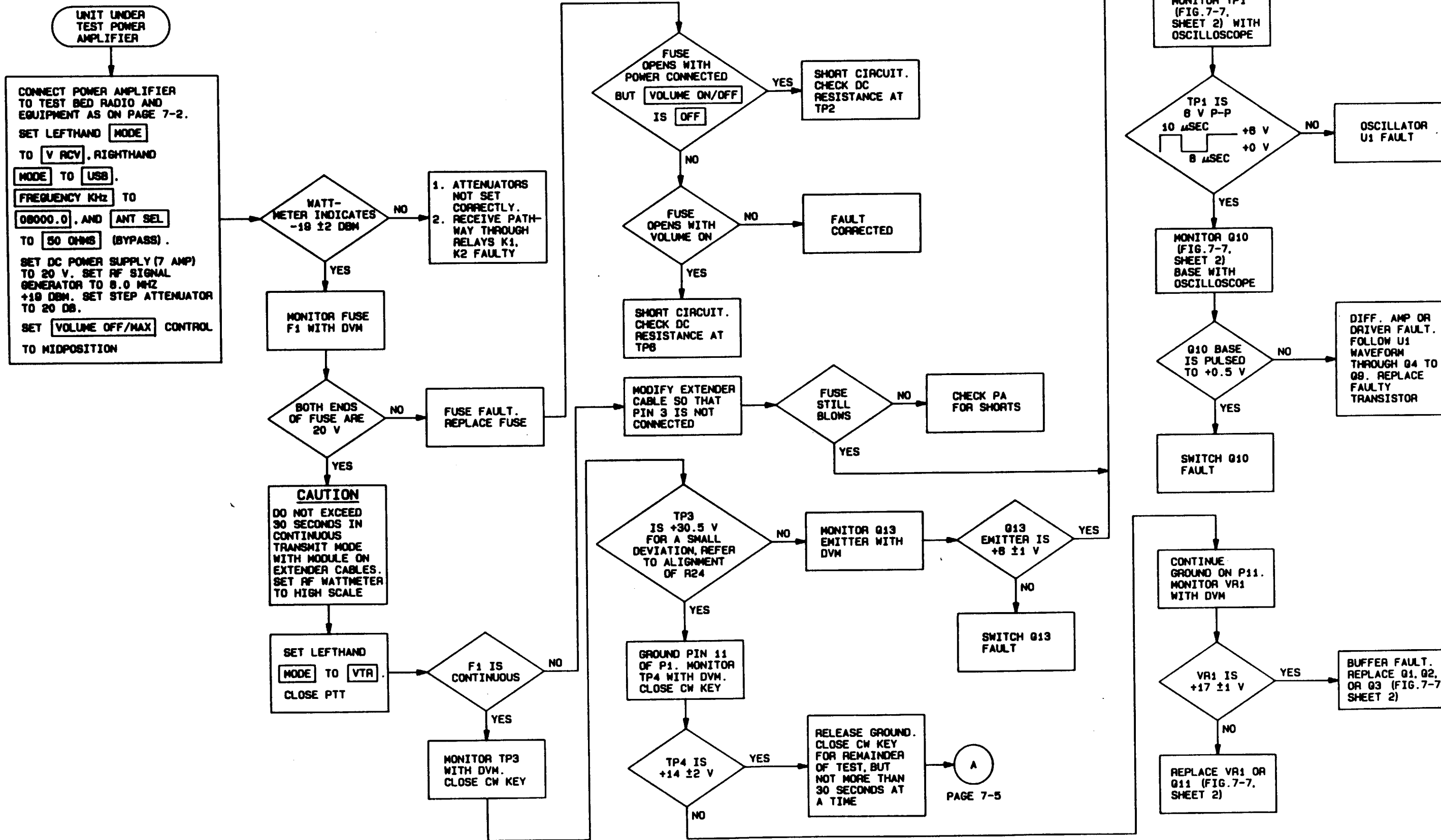

FIGURE B

BANDWIDTH	1 KHZ
SCAN WIDTH	0.05 MHZ
INPUT ATTENUATOR	10 DB
RANGE MHZ	0-110
CENTER FREQUENCY	16 MHZ
VIDEO FILTER	10 KHZ
SCAN MODE	SINGLE
10-DB LOG.	10-DB LOG.
SCAN TRIGGER	AUTO
LOG. REF	-20
LINEAR SENSITIVITY	0
SCAN (INNER RED)	PER DIV
SCAN TIME DIV	0.5 SEC
STORAGE	STD
INTENSITY	CENTERED
PERSISTENCE	90 - 180°
TIME	90°

STAJ-45104-7-1-2.1

**POWER AMPLIFIER FAULT ISOLATION PERFORMANCE TEST (2 of 4)**





**POWER AMPLIFIER FAULT ISOLATION PERFORMANCE TEST (3 of 4)**

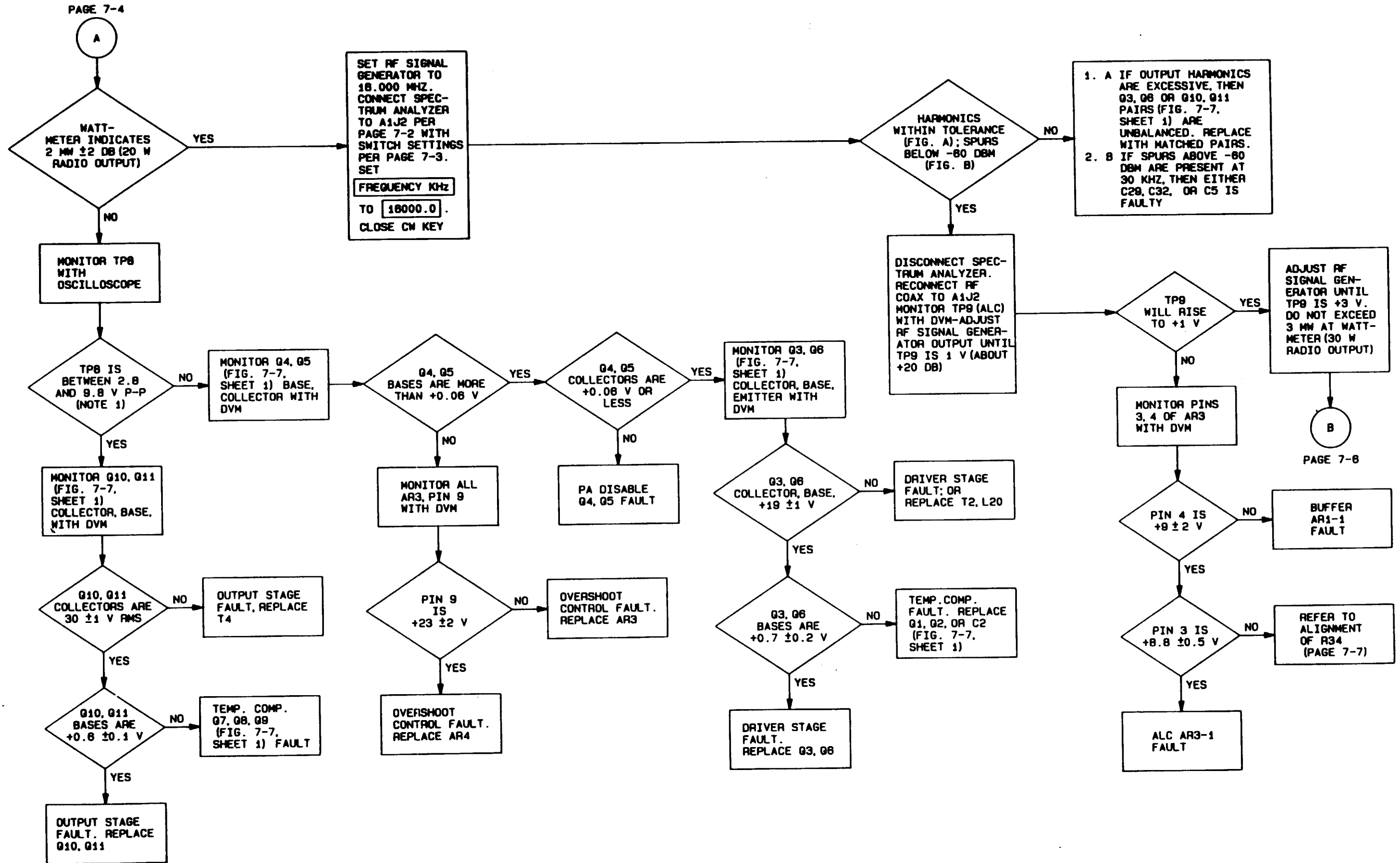

**POWER AMPLIFIER FAULT ISOLATION PERFORMANCE TEST (4 of 4)**

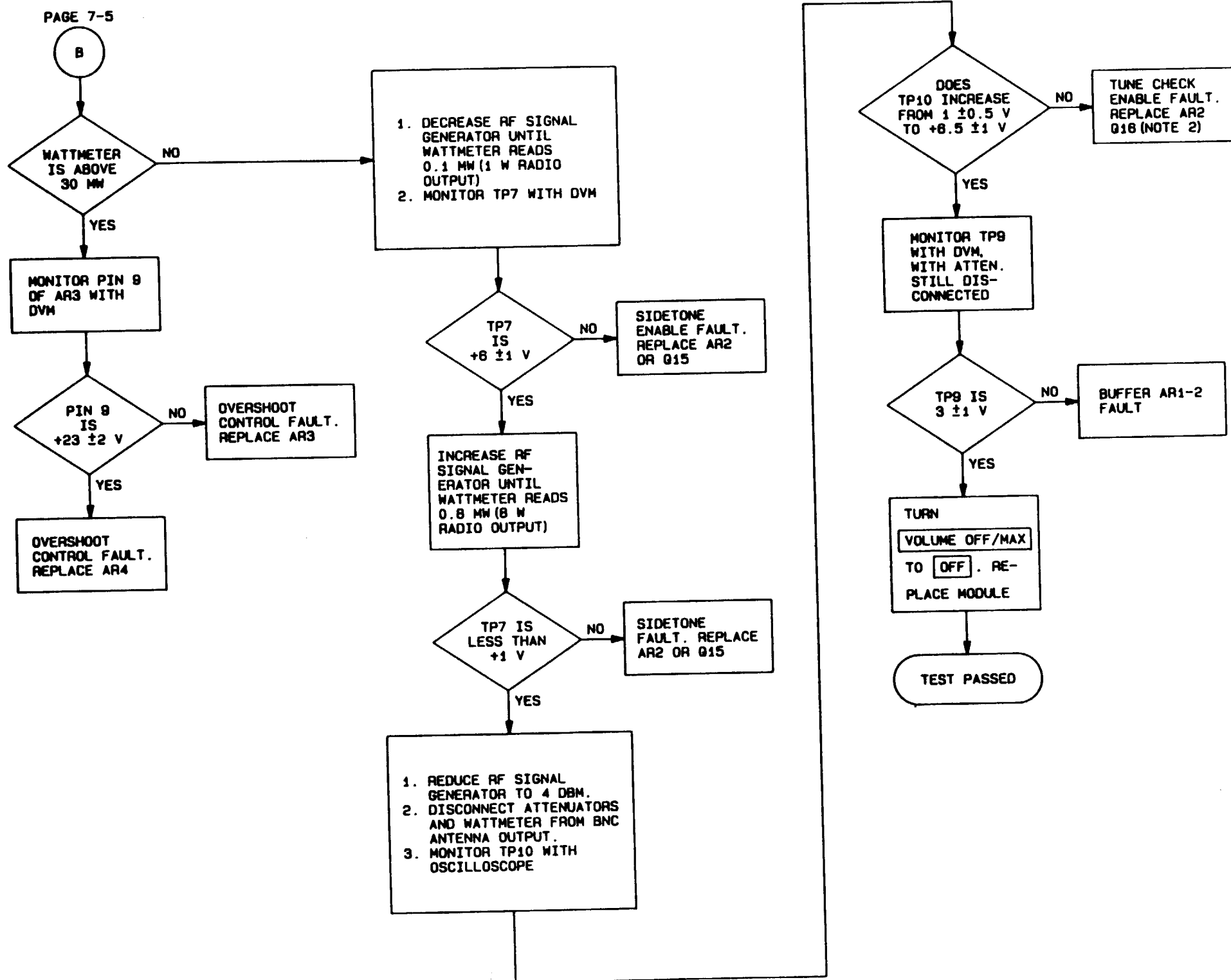

## POWER AMPLIFIER FAULT ISOLATION ALIGNMENT PROCEDURE

The alignment procedure is to be used in either of these situations: (1) the performance test calls a potentiometer out of adjustment, or (2) one of the following is replaced:

1. Overshoot control AR3, AR4.
2. ALC, AR3.
3. Buffers AR1, AR2.
4. Power transistors Q3, Q6, Q10, Q11 (fig. 7-7, sheet 1).
5. Transformers T1, T2, T3, T4, T5.
6. DC-DC converter.

The procedure consists of a preliminary setup and an adjustment procedure.

### PRELIMINARY SETUP

1. With all power off, remove the power amplifier module from the amplifier/coupler. Connect the test setup as shown on page 7-2, except that A1J1 will not be connected to the rf coaxial extender cable at this time. Connect the rf coax extender cable shown at A1J2 to the coaxial attenuator.
2. Set dc power supply (7 amp) to  $+24.5 \pm 0.1$  V dc. Set the coaxial attenuator to 10 db.
3. Set the ANT SEL switch to 50 OHMS (bypass), VOLUME OFF/MAX to midposition. Set FREQUENCY KHz to 29999.9, lefthand MODE to USB, and righthand MODE to VTR.

### ADJUSTMENT

#### NOTE

The following definitions apply for adjustments made in the steps below:

- R1 = gain adjust
- R13 = bias adjust
- R24 = +30.5 V dc adjust
- R34 = ALC reference adjust

1. Monitor power amplifier module TP3 with DVM. Press PTT (audio input/keying adapter). Adjust R24 (fig. 7-2, sheet 2) (bottom board) for  $+30.5 \pm 0.5$  V dc. Release PTT and set VOLUME OFF/MAX to OFF.
2. On the 18-pin extender cable, open pin 3 by removing the jumper wire between the two test points. Insert a 100 mA dc ammeter between these two test points ensuring that the negative ammeter test lead is connected to the test point nearest to the power amplifier module 18-pin connector. Turn VOLUME OFF/MAX to midposition.
3. Press PTT and adjust R13 (fig. 7-2, sheet 1) on the power amplifier module (top board) for 90 mA. The PTT switch should be pressed only long enough to adjust R13. Release PTT and wait 60 seconds. Press PTT and check the ammeter for a reading of 90 mA. Release PTT.
4. Remove the ammeter test leads from the extender cable test points. Reinstall the jumper wire to these test points.
5. Connect the rf coaxial cable from the rf signal generator to the power amplifier module A1J1. Adjust the rf output level of the signal generator to +22 dbm (150 mW) at 30 MHz. Refer to notes 7 and 8 on page 7-2.
6. Press PTT on the audio input/keying adapter and adjust R1 (fig. 7-2, sheet 1) for a reading of 27 mW on the power meter ( $23 \pm 3$  W at A1J2). Release PTT.
7. Monitor E8 on bottom board assembly 755002A0668 with a DVM. Press PTT and adjust R34 (fig. 7-2, sheet 1) for a reading of  $+13.5 \pm 0.5$  V dc.
8. Release PTT. Turn off all power to the power amplifier module. Disconnect all test equipment.

**ANTENNA TUNER FAULT ISOLATION**

The antenna tuner fault isolation procedure is divided into the following: special tools and test equipment, performance test setup, performance test, and alignment procedure.

**ANTENNA TUNER FAULT ISOLATION SPECIAL TOOLS AND TEST EQUIPMENT**

Description	Part Number
Antenna Tuner Test Extender Cable	...
Audio input/Keying Adapter	...
Tool Kit, Electronic	TK-105/G
Bench Repair Center	Pace PRC-350C
Maintenance Kit, printed Circuit	MK-984/A
Radio Set, Test Bed	AN/PRC-104
VTVM	
Signal Generator, RF	
Oscilloscope	

Description	
Digital Multimeter (DVM, ohmmeter function)	
Attenuator, Step 10-db steps, 0.5 W, 50 ohms	
Dummy Load (50 ohms) 20 W minimum	
Wattmeter	
— Power Meter	
— Thermocouple Power Sensor	
Power Supply, Current Limited	
Power Supply, DC	
Attenuator, Coaxial 20 db, 30 W min, 50 ohms	Narda 765-20

**NOTE**

Refer to page 1-6 for test equipment characteristics.

**ANTENNA TUNER FAULT ISOLATION PERFORMANCE TEST SETUP**

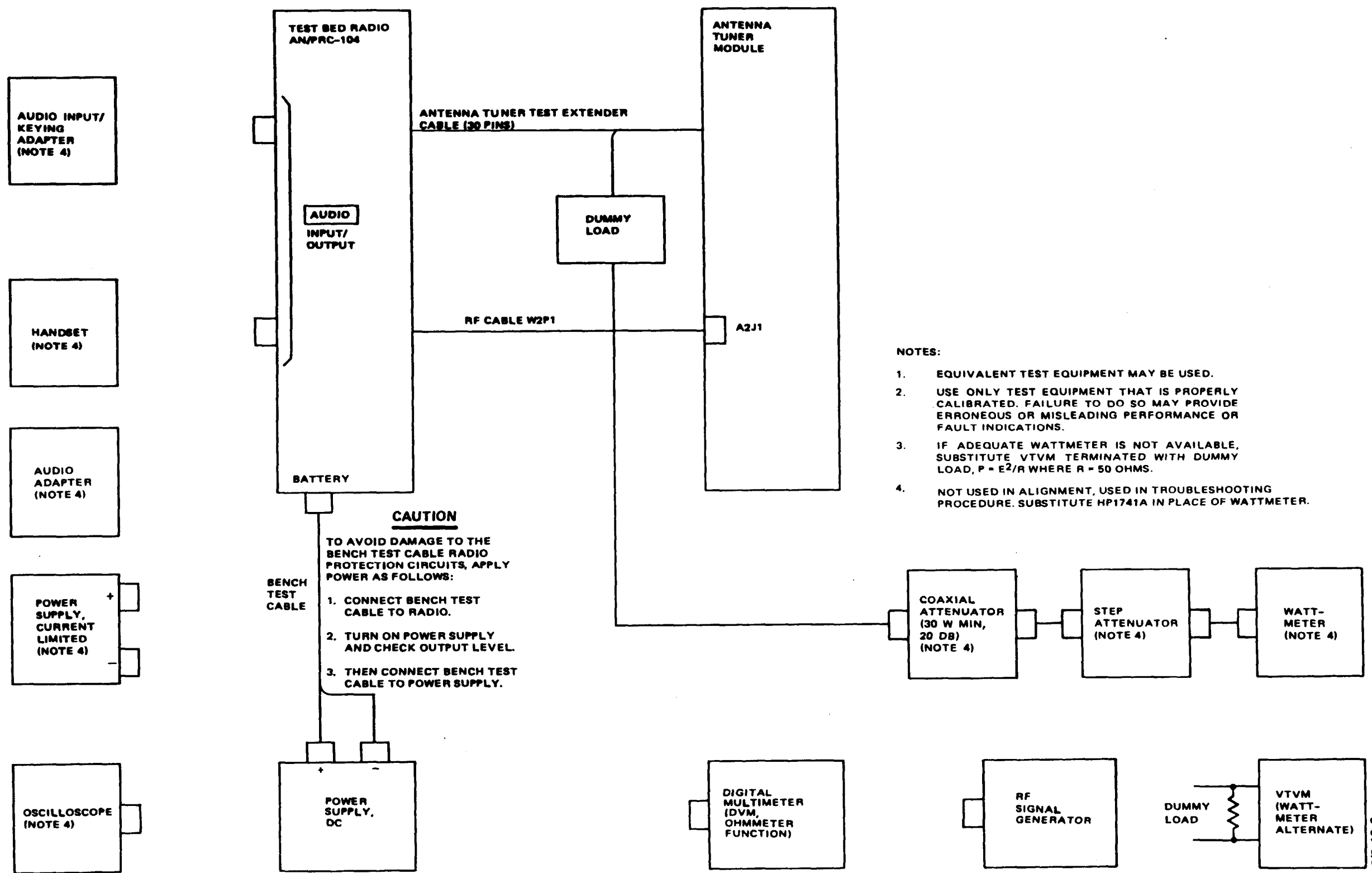

- NOTES:**
1. EQUIVALENT TEST EQUIPMENT MAY BE USED.
  2. USE ONLY TEST EQUIPMENT THAT IS PROPERLY CALIBRATED. FAILURE TO DO SO MAY PROVIDE ERRONEOUS OR MISLEADING PERFORMANCE OR FAULT INDICATIONS.
  3. IF ADEQUATE WATTMETER IS NOT AVAILABLE, SUBSTITUTE VTVM TERMINATED WITH DUMMY LOAD,  $P = E^2/R$  WHERE  $R = 50$  OHMS.
  4. NOT USED IN ALIGNMENT, USED IN TROUBLESHOOTING PROCEDURE. SUBSTITUTE HP1741A IN PLACE OF WATTMETER.

Figure 7-2 Antenna Tuner Fault Isolation Performance Test Setup

104-4873-10-3

**ANTENNA TUNER FAULT ISOLATION PERFORMANCE TEST (1 of 5)**

**NOTES**

1. Changing the lefthand MODE pushbutton from VTR to V RCV to VTR causes a tune start signal to be routed from the modulator/demodulator. This causes all capacitive and inductive elements to be removed from the rf pathway. When the PTT or CW key is closed, the inductors and capacitors are added.
2. A voltage difference of 1.5 V ac or greater across the coil indicates that the relay is open. The coil is then in the rf pathway. After a tune start, and before PTT is closed, all coil relays should be closed.
3. If a coil is replaced, be sure that its inductance is exactly ( $\pm 1$  percent) one-half of next larger coil.
4. Unless otherwise specified, all voltage measurements are taken with respect to ground.
5. Hybrid binary count faults can be investigated as follows:
  - a. Monitor TP10 with DVM and record voltage measurement.
  - b. Set TP10 to 0 V (this disables comparator) by adjusting R4.
  - c. Monitor S and R terminals for KL1 thru KL11 relays and compare waveforms to those of a functional module (ensure the 'L' count is performed properly).
  - d. Set TP10 to +6 V by adjusting R4.
  - e. Monitor TP8 and TP9 with DVM and record voltage measurement.
  - f. Set TP8 and TP9 to +0 V (this disables comparator) by adjusting R2 and R3, respectively.
9. Monitor S and R terminals for KC1 thru KC8 relays and compare waveforms to those of a functional module (ensure the 'C' count is performed properly).
- h. Reset TP8, TP9, and TP10 to the values recorded in steps a and e.
6. Component failures due to untraceable faults require special handling at a factory or depot location using a test fixture and a vector Impedance meter. If performance is not satisfactory and a tune-fault does not occur, then refer module to fifth echelon repair level.

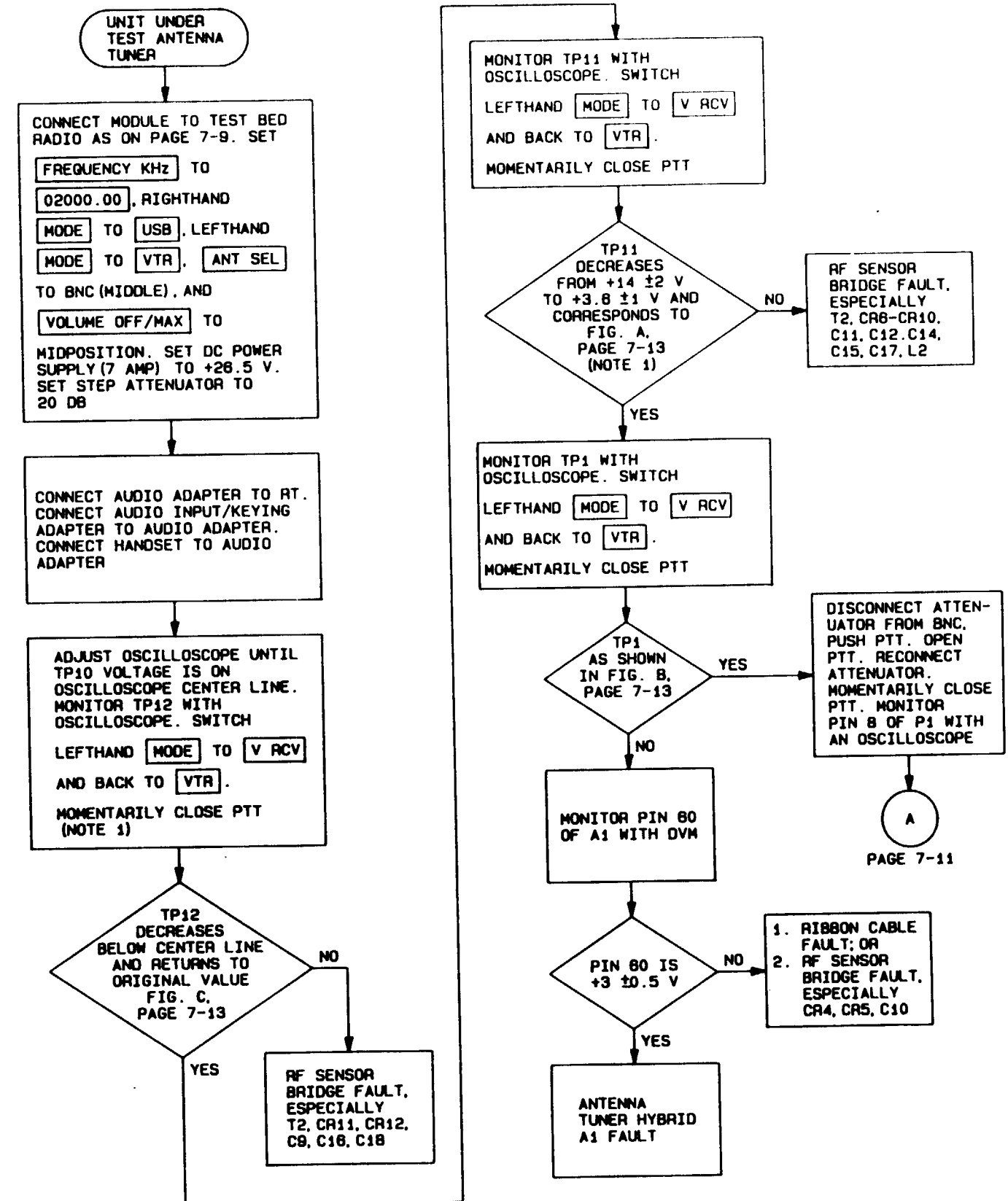

**ANTENNA TUNER FAULT ISOLATION PERFORMANCE TEST (2 of 5)**

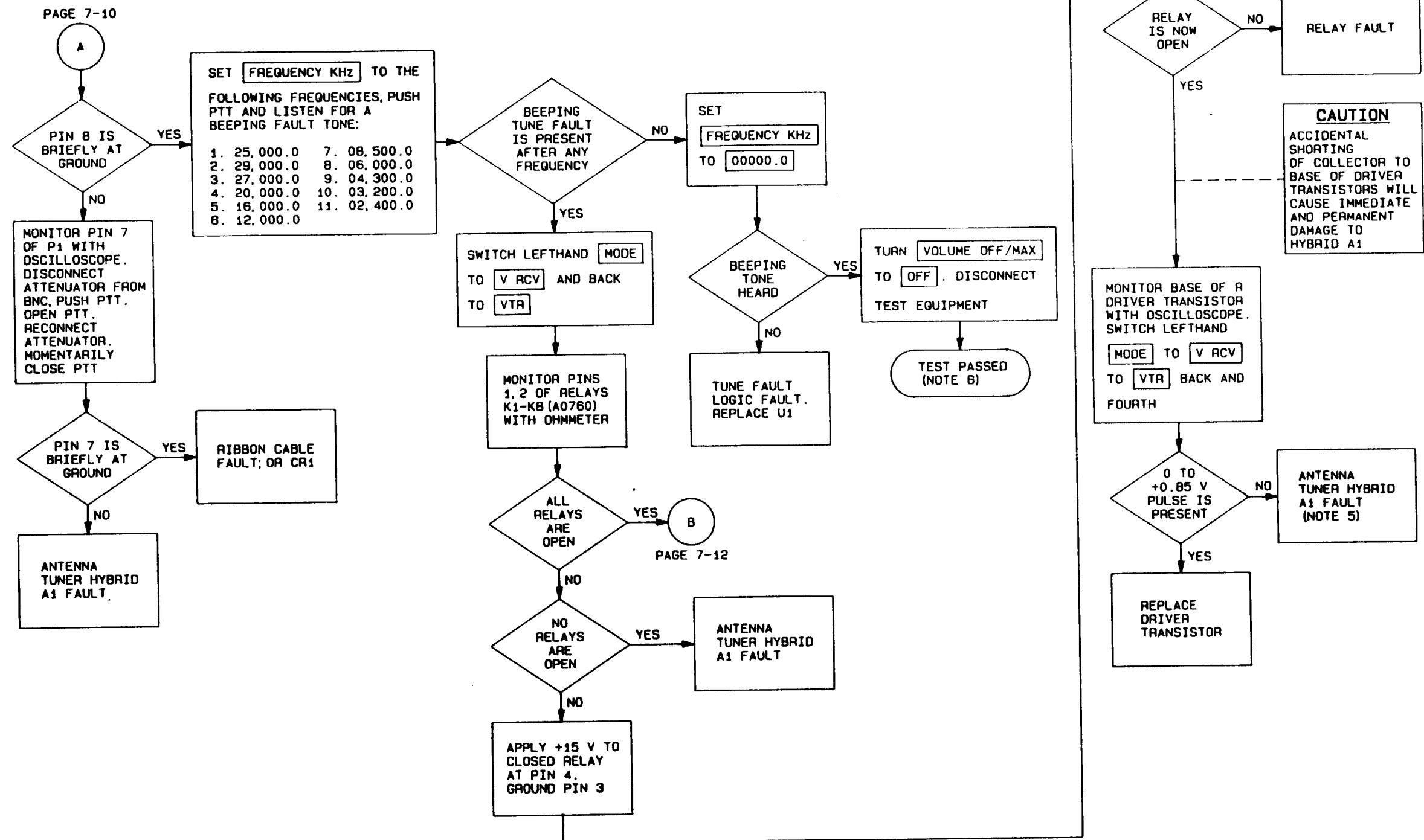

**ANTENNA TUNER FAULT ISOLATION PERFORMANCE TEST (3 of 5)**

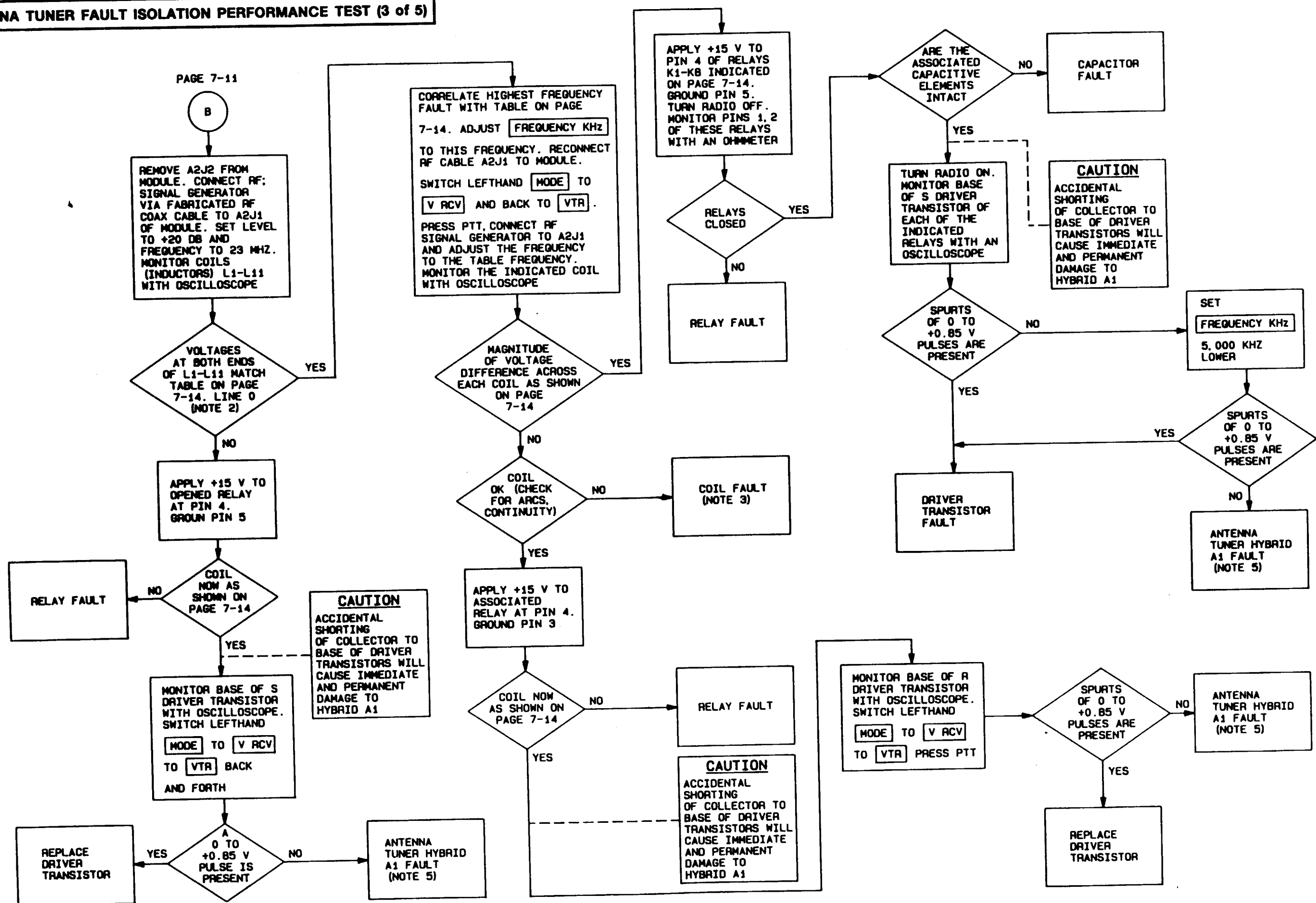



**ANTENNA TUNER FAULT ISOLATION PERFORMANCE TEST (4 of 5)**

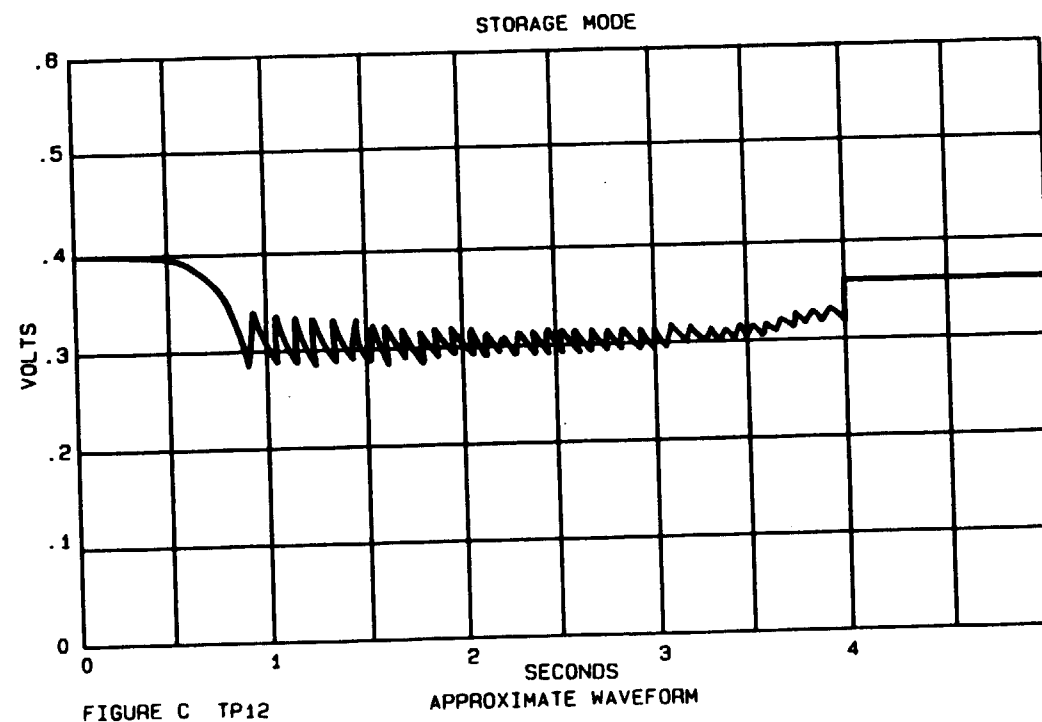
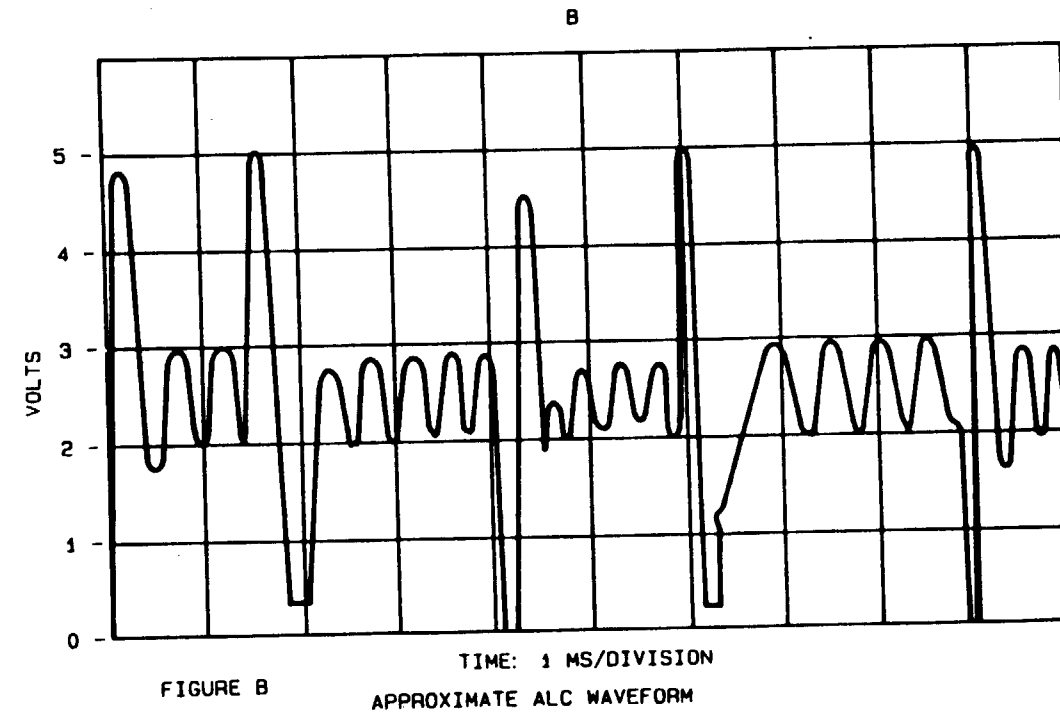
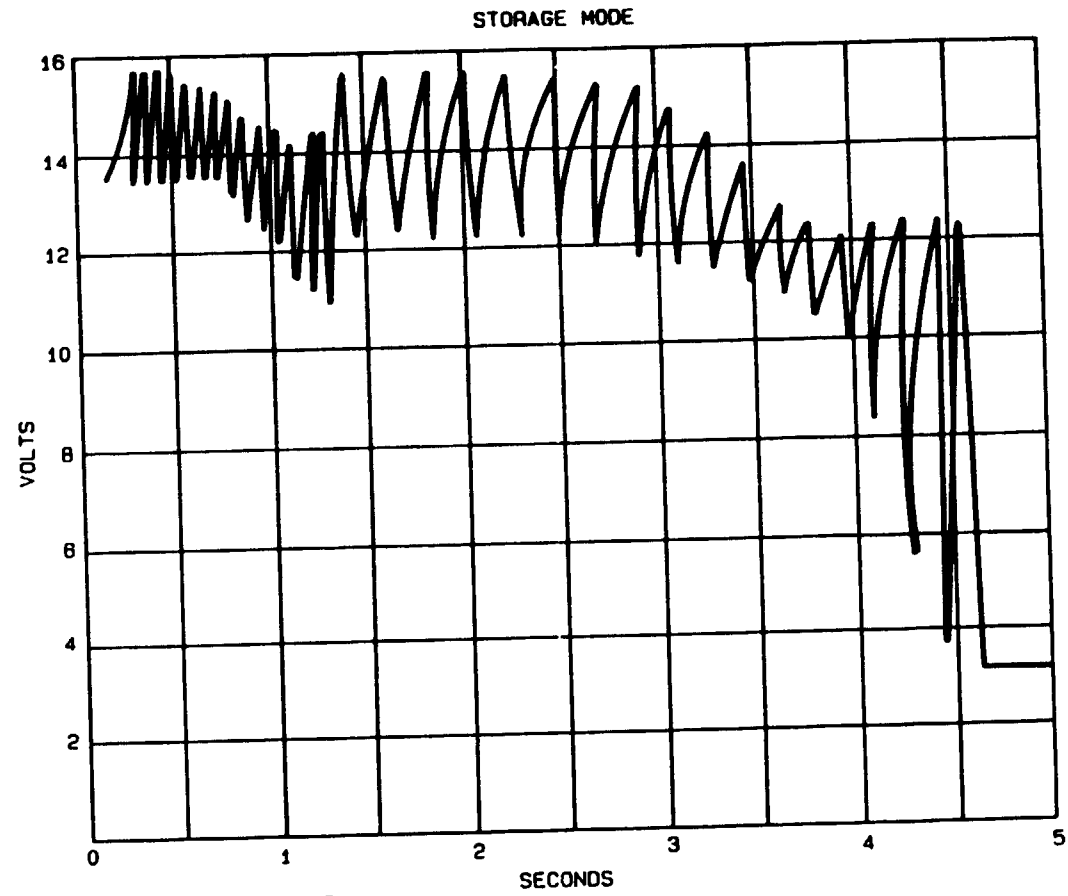

HP-1741A WITH 10:1 PROBE V/DIV 0.1 TIME/DIV 0.5 SEC  
 SWEEP VERNIER 1-2 0'CLOCK TRIGGER LEVEL 1 0'CLOCK  
 AUTO NORM TO NORM POS NEG TO POS

**ANTENNA TUNER FAULT ISOLATION PERFORMANCE TEST (5 of 5)**

FAULT FREQUENCY CORRESPONDS TO FREQUENCY KHZ AND RF SIGNAL GENERATOR FREQUENCY FOR COIL AND RELAY CHECK	INDUCTORS (COILS) L1-L11 ARE IN PARALLEL WITH RELAYS K1-K11. TO DETERMINE WHETHER A GIVEN RELAY IS OPEN OR CLOSED, THE IMPEDANCE OF THE INDUCTOR (COIL) IS MEASURED AT A HIGH FREQUENCY BY CHECKING THE VOLTAGE DIFFERENCE ACROSS THE INDUCTORS (COILS). THESE ARE SOME TYPICAL PEAK-TO-PEAK COIL VOLTAGES, WHERE A/B IS COIL IN VOLTS/ COIL OUT VOLTS (WITH RESPECT TO GROUND). A VOLTAGE DIFFERENCE OF 1.5 V OR GREATER INDICATES AN OPEN RELAY.											CAPACITIVE RELAYS TO CHECK FOR EACH FREQUENCY							
	L1	L2	L3	L4	L5	L6	L7	L8	L9	L10	L11	K1	K2	K3	K4	K5	K6	K7	K8
0. 23,000	3/3	3/3.5	3.5/3.8	3.8/.4	4/4.5	4.5/4.8	4.5/5	5/5.5	5.5/6	6/6	6/6.2	0	0	0	0	0	0	0	0
1. 25,000	10/8*	8/8	8/5*	5/5.5								X	X	X					
2. 28,000	10/8.5	8.5/7*	7/7									X	X	X					
3. 27,000		10/10	10/4.5*	8.5/4.5								X	X	X					
4. 20,000			8/6	8/15*	15/15									X	X	X			
5. 18,000				7/6	8/23*	23/23								X	X	X			
6. 12,000					5/5	5/35*	35/35							X	X	X			
7. 08,500						3.8/3.5	3.5/40*	40/40							X	X	X		
8. 06,000							2.5/2.5	2.5/18*	18/18						X	X	X		
9. 04,300								14/14	14/60*	60/60					X	X	X		
10. 03,200									27/27	27/50*	50/50				X	X	X		
11. 02,400										30/30	30/60*				X	X	X		

X - CHECK THESE RELAYS BY APPLYING +15 V TO PIN 4 AND GROUND PIN 5.

**ANTENNA TUNER FAULT ISOLATION ALIGNMENT PROCEDURE (1 of 2)**

The alignment procedure is to be used in either of these situations: (1) the performance test calls a potentiometer out of adjustment, or (2) the rf sensor bridge is replaced.

The procedure consists of special tools and test equipment, alignment setup, preliminary setup, and adjustment procedure. The adjustment procedure can be shortened by adjusting R1, R2, R3, and R4 to the values given in step 13 on page 7-16. The complete procedure need only be run if work has been done on the rf sensor bridge.

**SPECIAL TOOLS AND TEST EQUIPMENT FOR ALIGNMENT**

Description	Part Number
100-Ohm Load	...
130-Ohm Load	...
RF Coax Cable	...
Audio Input/Keying Adapter	...
Radio Set, Test Bed	AN/PRC-104
Signal Generator, RF	
Digital Multimeter (DVM, ohmmeter function)	
Power Supply, DC	

**NOTE**

Refer to page 1-6 for test equipment characteristics.

**ALIGNMENT SETUP**

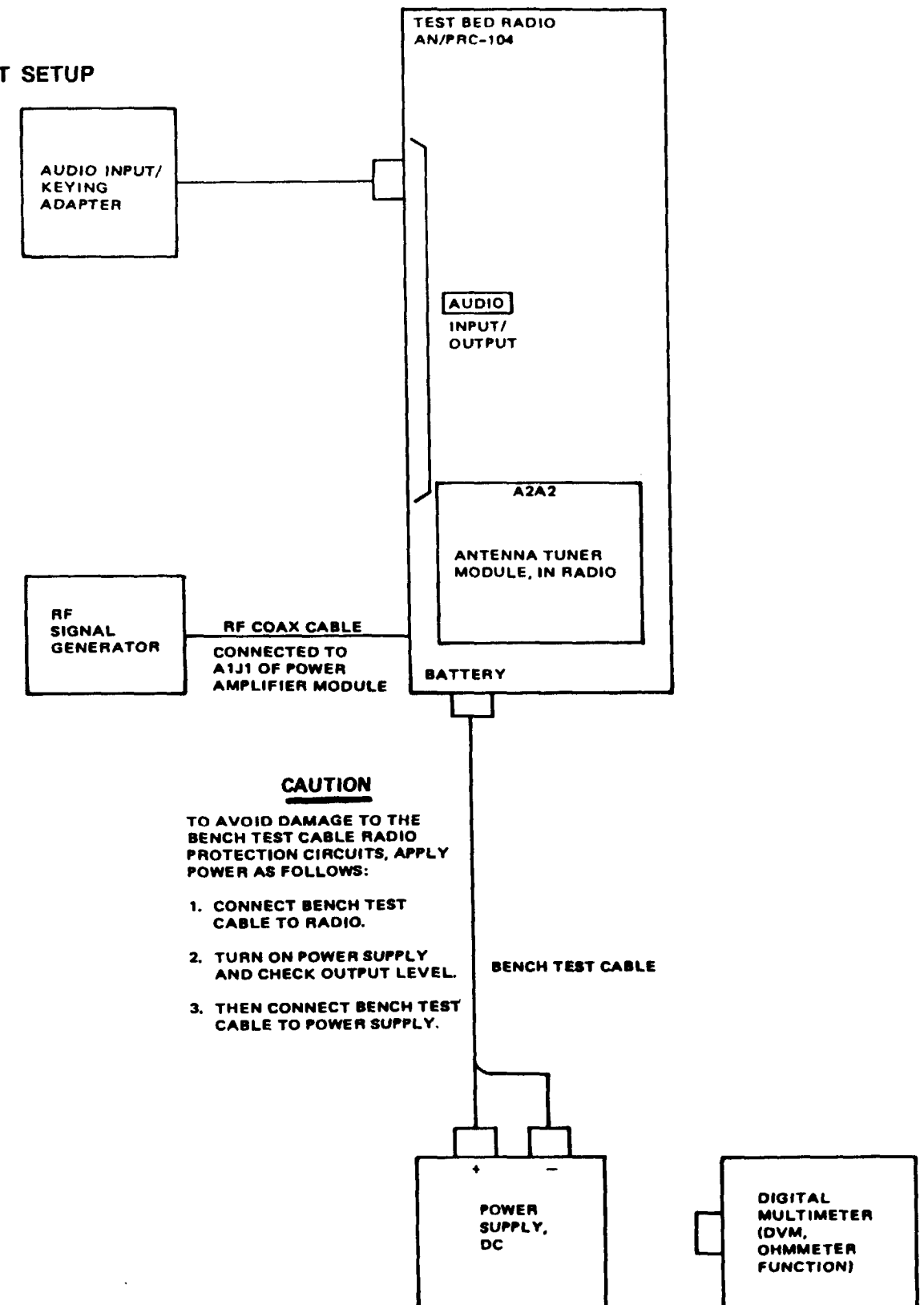

Figure 7-3. Antenna Tuner Fault Isolation Alignment Procedure

**ANTENNA TUNER FAULT ISOLATION ALIGNMENT PROCEDURE (2 of 2)**

**PRELIMINARY SETUP**

1. Connect test radio as on page 7-15.
2. Connect an rf signal generator to the input of the power amplifier module at A1J1. Set the level to -100 dbm and the frequency to 2.000 MHz.
3. Connect the 130-ohm load to the radio set BNC connector.
4. Set the radio controls to the following:
  - a. FREQUENCY KHz to 02000.0
  - b. Lefthand MODE to VTR
  - c. Righthand MODE to USB
  - d. VOLUME OFF/MAX to midposition
  - e. ANT SEL to BNC

ADJUSTMENT

**NOTE**

If module is removed from radio for any adjustment, repeat steps 1 and 2.

1. Switch lefthand MODE to V RCV and back to VTR. Close CW key and hold. This generates a tune start pulse and dumps the antenna tuner module.
2. Ground (continuously) E7 of ribbon cable.

3. Adjust the rf signal generator so that the voltage at TP13 varies between +7 and +14 V (+7 V = 1 W, +14 V = 4 W) and measure the output of the vswr detector at TP11. Do not stay at the 4 W level for any length of time.
4. Verify the level compensation resistor, R7, is adjusted for a variation in dc output of less than 0.1 V dc at TP11 as performed in step 3.
5. Once R7 is adjusted, adjust the rf signal generator so that TP13 is +10 V rms. Note the voltage at TP11.
6. Adjust R3 until the 1.5 vswr reference voltage, TP9, is the same as that noted in step 5.
7. Adjust R2 until the 1.6 vswr reference voltage at TP8 is +0.6 V higher than that of TP9.
  - a. Replace the 130-ohm load with the 100-ohm load.
9. Increase level of rf signal generator until TP13 is +10 V rms. This corresponds to 2 W in a 50-ohm system.
10. Measure the dc output of the Z sensor at TP12. Record voltage at TP12.
11. Adjust R4 until the Z comparator reference voltage, TP10, is the same as that measured in step 10.
12. Adjust R1 until the voltage at TP7 is +3.0 V.
13. The following are typical settings after alignment:

ALC	REF	R1	TP7	+3.0 V
1.6	REF	R2	TP8	+4.3 V
1.5	REF	R3	TP9	+3.7 V
ZREF		R4	TP10	+3.2 V

14. Turn radio off and disconnect test equipment.

## Section II. Amplifier/Coupler Component Location

	Page
General .....	7-17
Power Amplifier Component Location .....	7-18
Antenna Tuner Component Location .....	7-20

### **GENERAL**

This section contains parts location diagrams and parts lists for the amplifier/coupler modules. This information is provided for the power amplifier and antenna tuner.

**POWER AMPLIFIER COMPONENT LOCATION (1 of 2)**

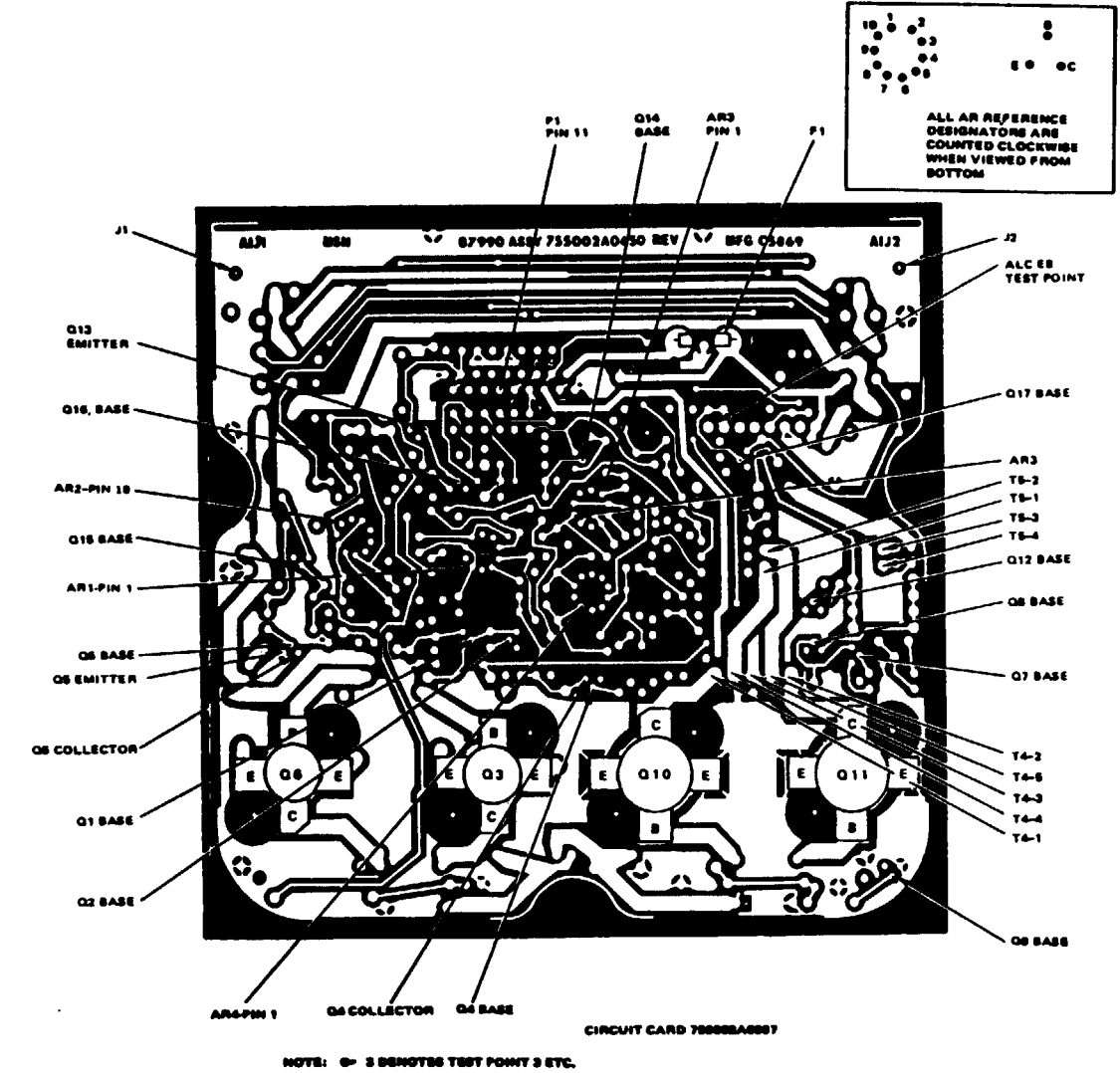
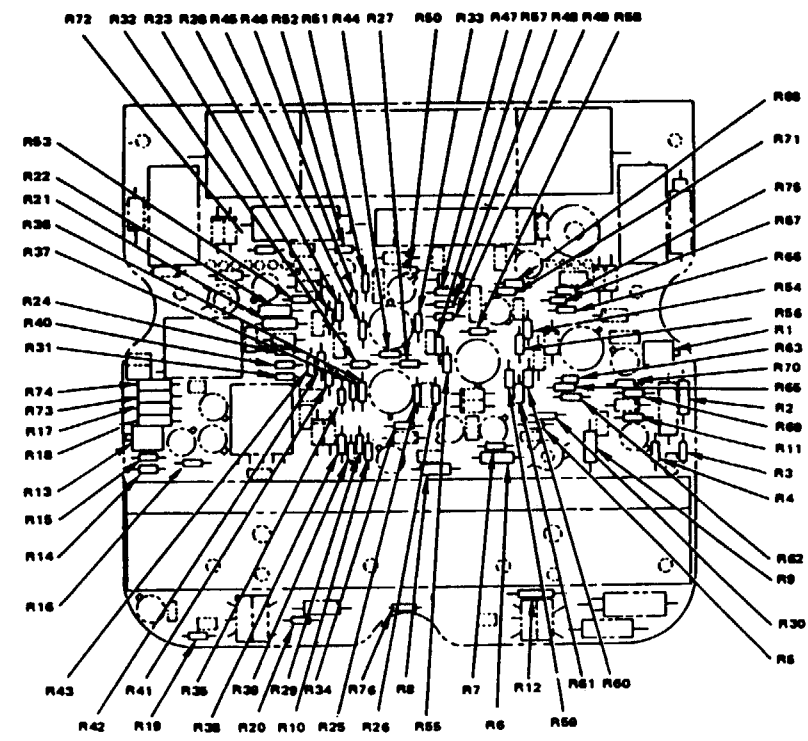
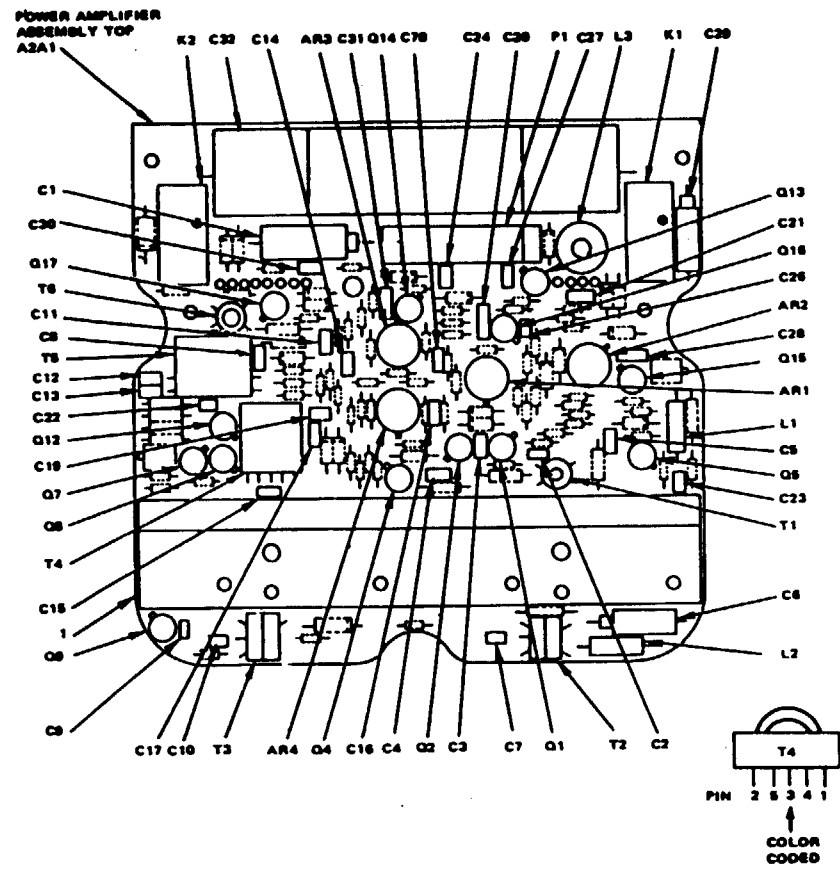

ALL AR REFERENCE DESIGNATORS ARE COUNTED CLOCKWISE WHEN VIEWED FROM BOTTOM

Figure 7-4. Power Amplifier Component Location (Sheet 1)

**POWER AMPLIFIER COMPONENT LOCATION (2 of 2)**

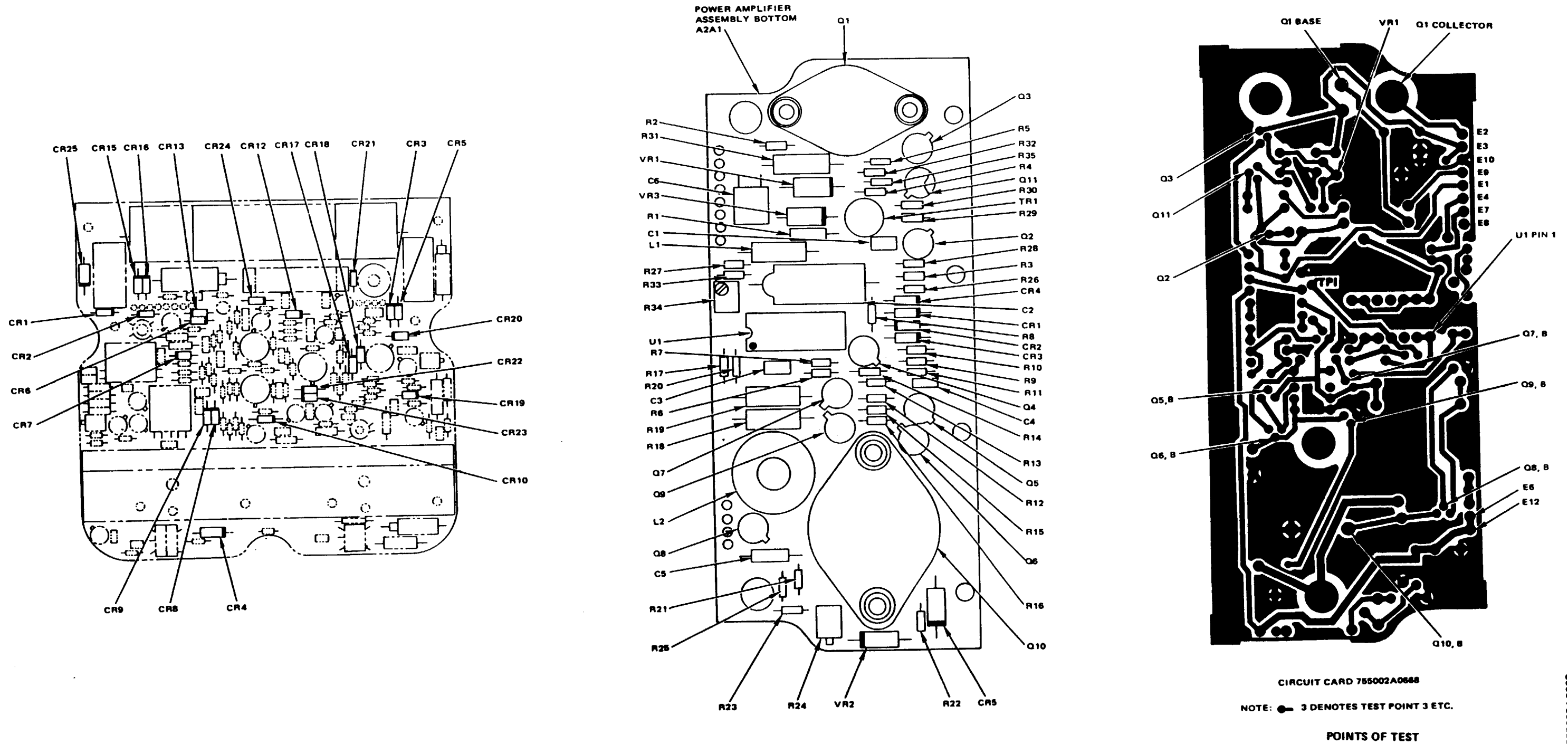

Figure 7-4. Power Amplifier Component Location (Sheet 2)

**ANTENNA TUNER COMPONENT LOCATION (1 of 2)**

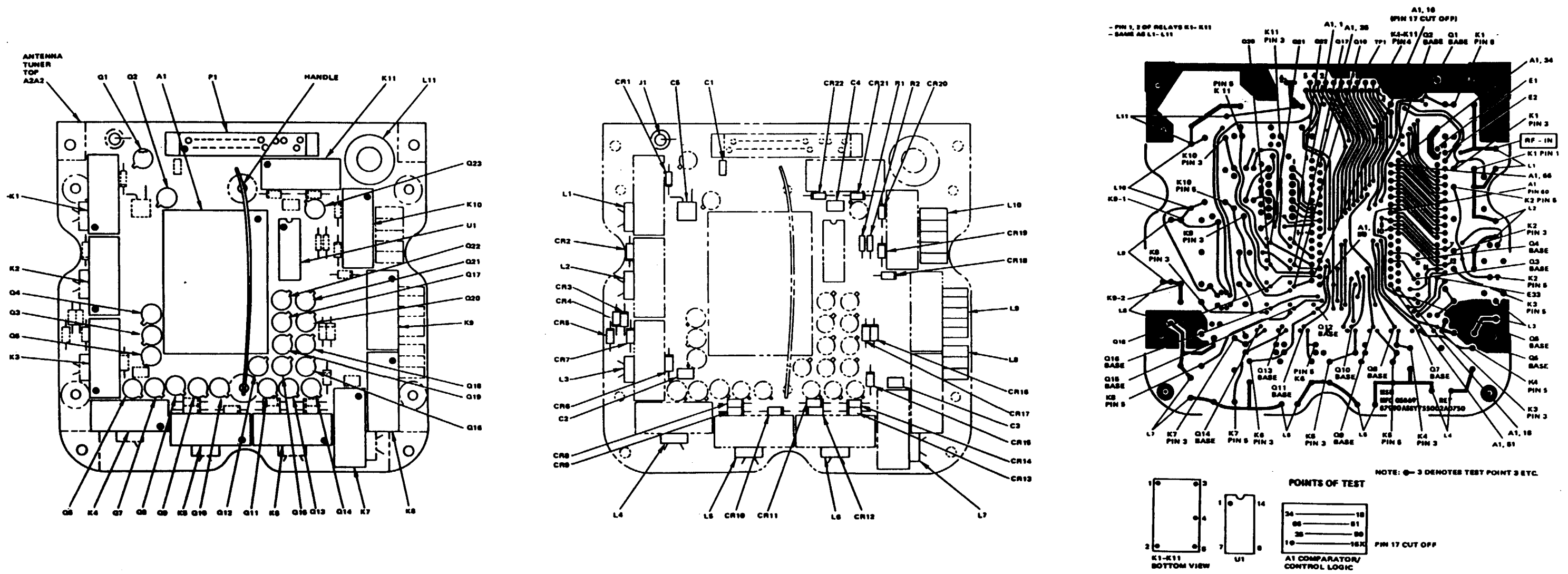

Figure 7-5. Antenna Tuner Component Location (Sheet 1)

785002A0789



**ANTENNA TUNER COMPONENT LOCATION (2 of 2)**

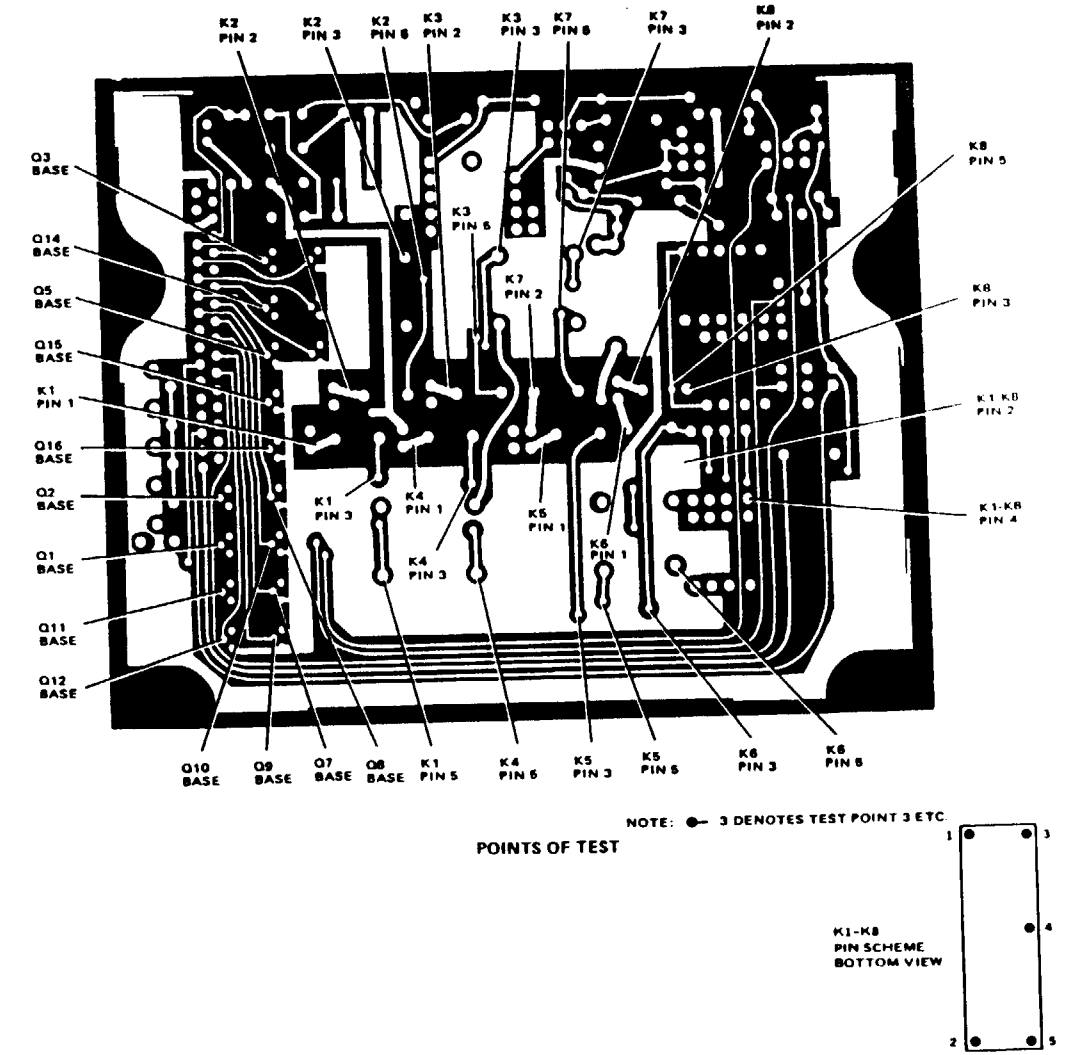
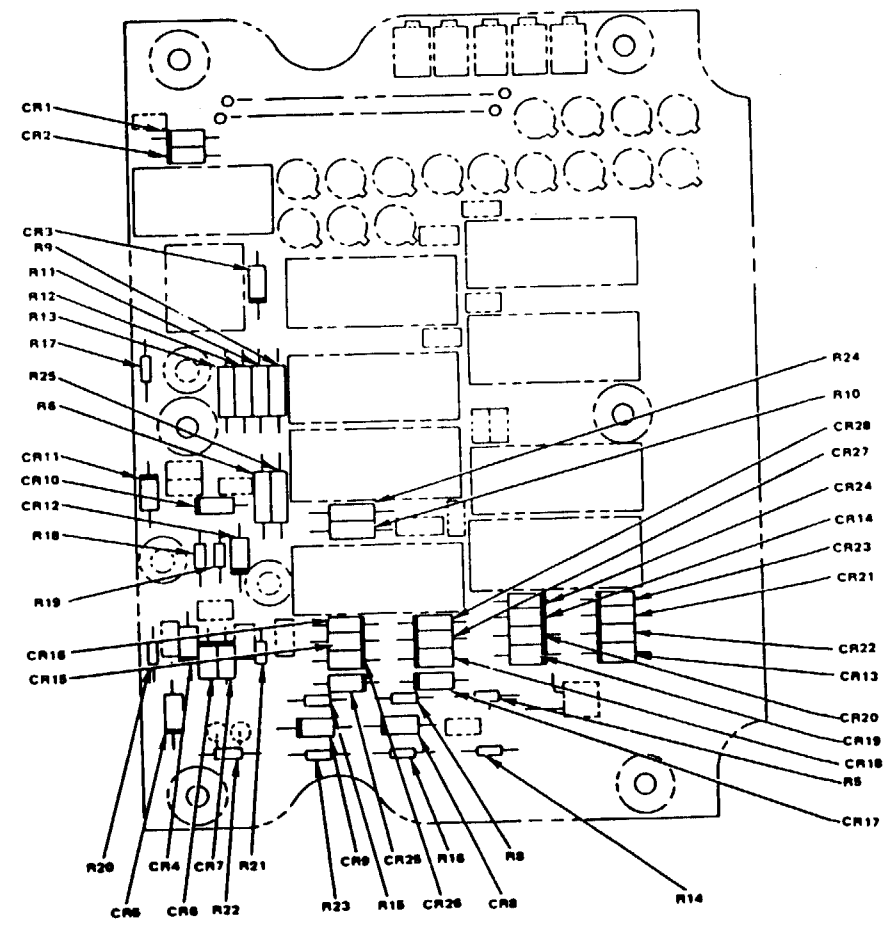
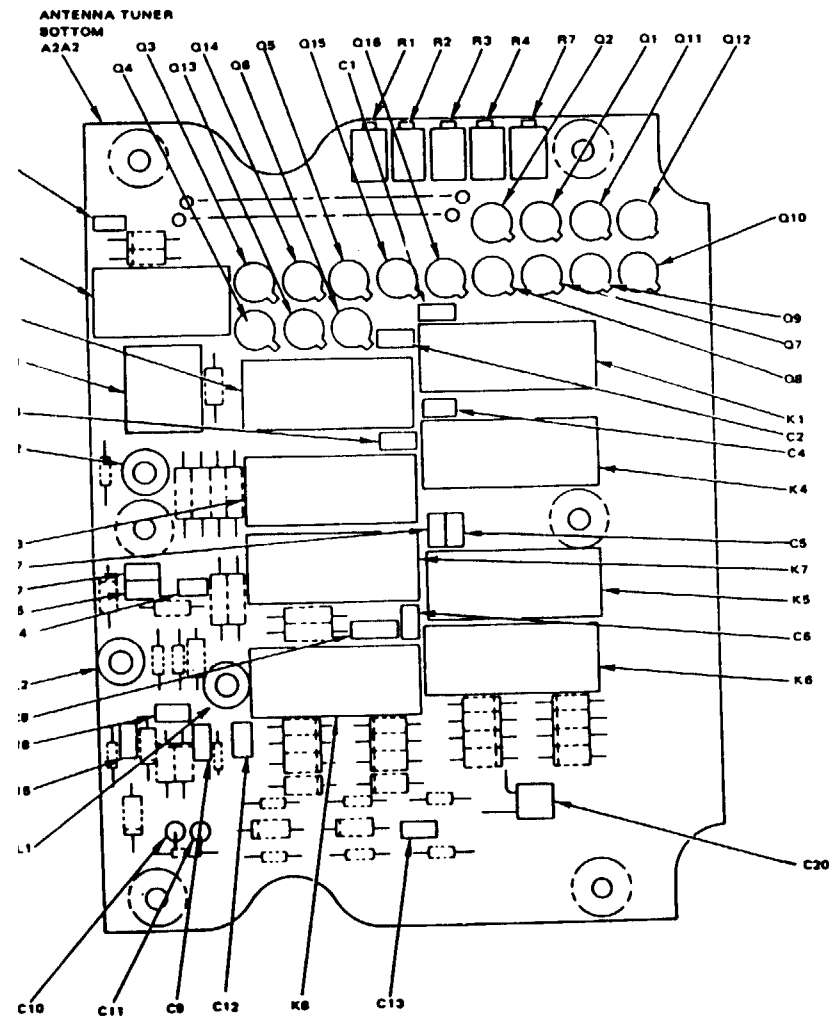

Figure 7-5. Antenna Tuner Component Location (Sheet 2)

755002A0760

BLANK  
INTENTIONALLY

### Section III. AMPLIFIER/COUPLER SCHEMATIC DIAGRAMS

	Page
General .....	7-23
Amplifier/Couplar Schematic Diagram .....	7-24
Power Amplifier Schematic Diagram .....	7-25
Antenna Tuner Schematic Diagram .....	7-27

**GENERAL**

This section contains detailed schematic diagrams to be used by the technician to troubleshoot the amplifier/coupler. Schematic diagrams are provided for the power amplifier and antenna tuner.

**AMPLIFIER/COUPLER SCHEMATIC DIAGRAM**

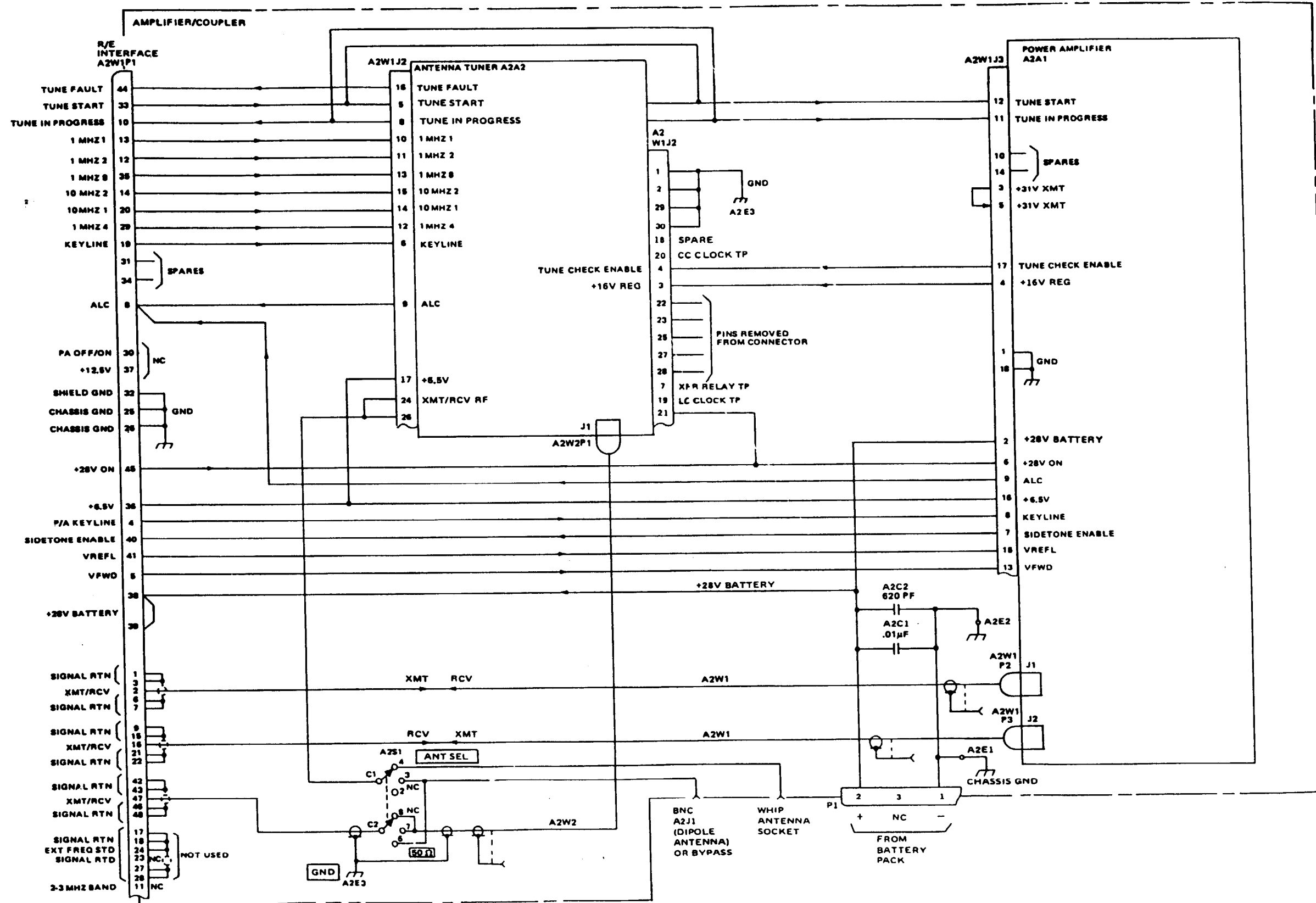
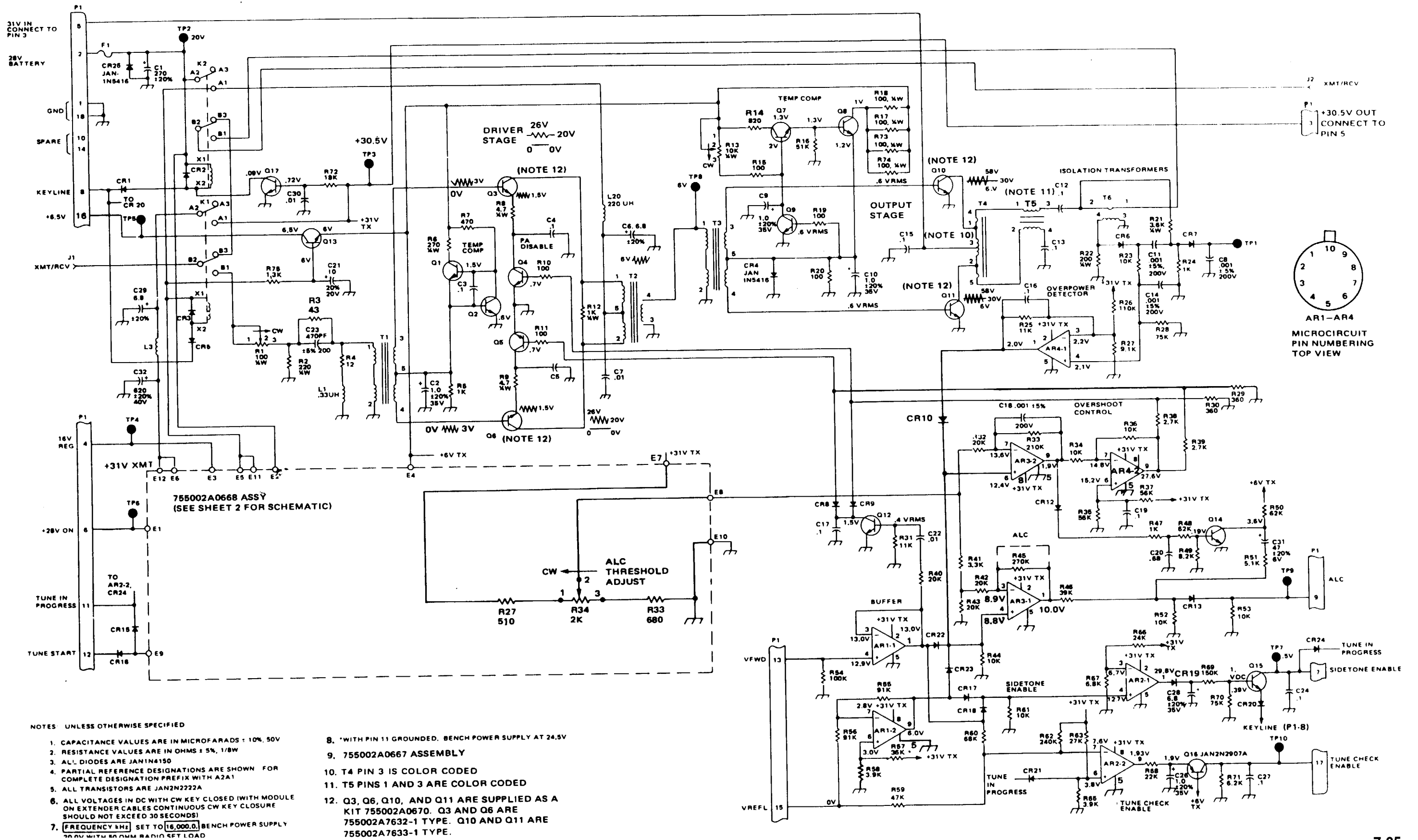

Figure 7-6. Amplifier/Coupler Schematic

**POWER AMPLIFIER SCHEMATIC DIAGRAM (1 of 2)**



**NOTES UNLESS OTHERWISE SPECIFIED**

1. CAPACITANCE VALUES ARE IN MICROFARADS: 10%, 50V
2. RESISTANCE VALUES ARE IN OHMS: 5%, 1/8W
3. ALL DIODES ARE JAN1N4150
4. PARTIAL REFERENCE DESIGNATIONS ARE SHOWN FOR COMPLETE DESIGNATION PREFIX WITH A2A1
5. ALL TRANSISTORS ARE JAN2N2222A
6. ALL VOLTAGES IN DC WITH CW KEY CLOSED (WITH MODULE ON EXTENDER CABLES CONTINUOUS CW KEY CLOSURE SHOULD NOT EXCEED 30 SECONDS)
7. **FREQUENCY (KHZ)** SET TO **16,000.0**, BENCH POWER SUPPLY 28.0V WITH 200MM RADIO SET LOAD
8. \*WITH PIN 11 GROUNDING. BENCH POWER SUPPLY AT 24.5V
9. 755002A0667 ASSEMBLY
10. T4 PIN 3 IS COLOR CODED
11. T5 PINS 1 AND 3 ARE COLOR CODED
12. Q3, Q6, Q10, AND Q11 ARE SUPPLIED AS A KIT 755002A0670. Q3 AND Q6 ARE 755002A7632-1 TYPE. Q10 AND Q11 ARE 755002A7633-1 TYPE.

Figure 7-7. Power Amplifier Schematic Diagram (Sheet 1)

**POWER AMPLIFIER SCHEMATIC DIAGRAM (2 of 2)**

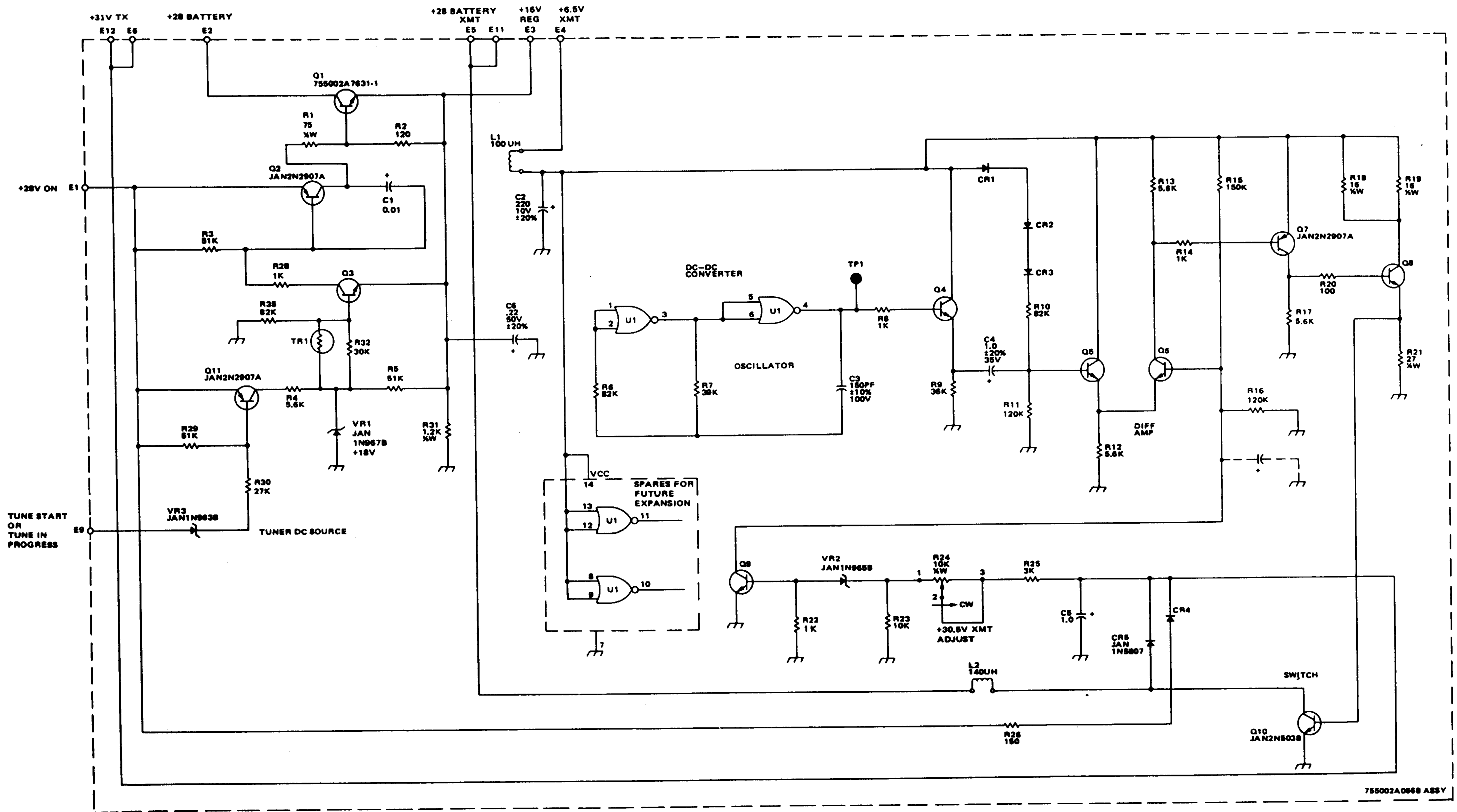

Figure 7-7. Power Amplifier Schematic Diagram (Sheet 2)

ANTENNA TUNER SCHEMATIC DIAGRAM (1 of 2)

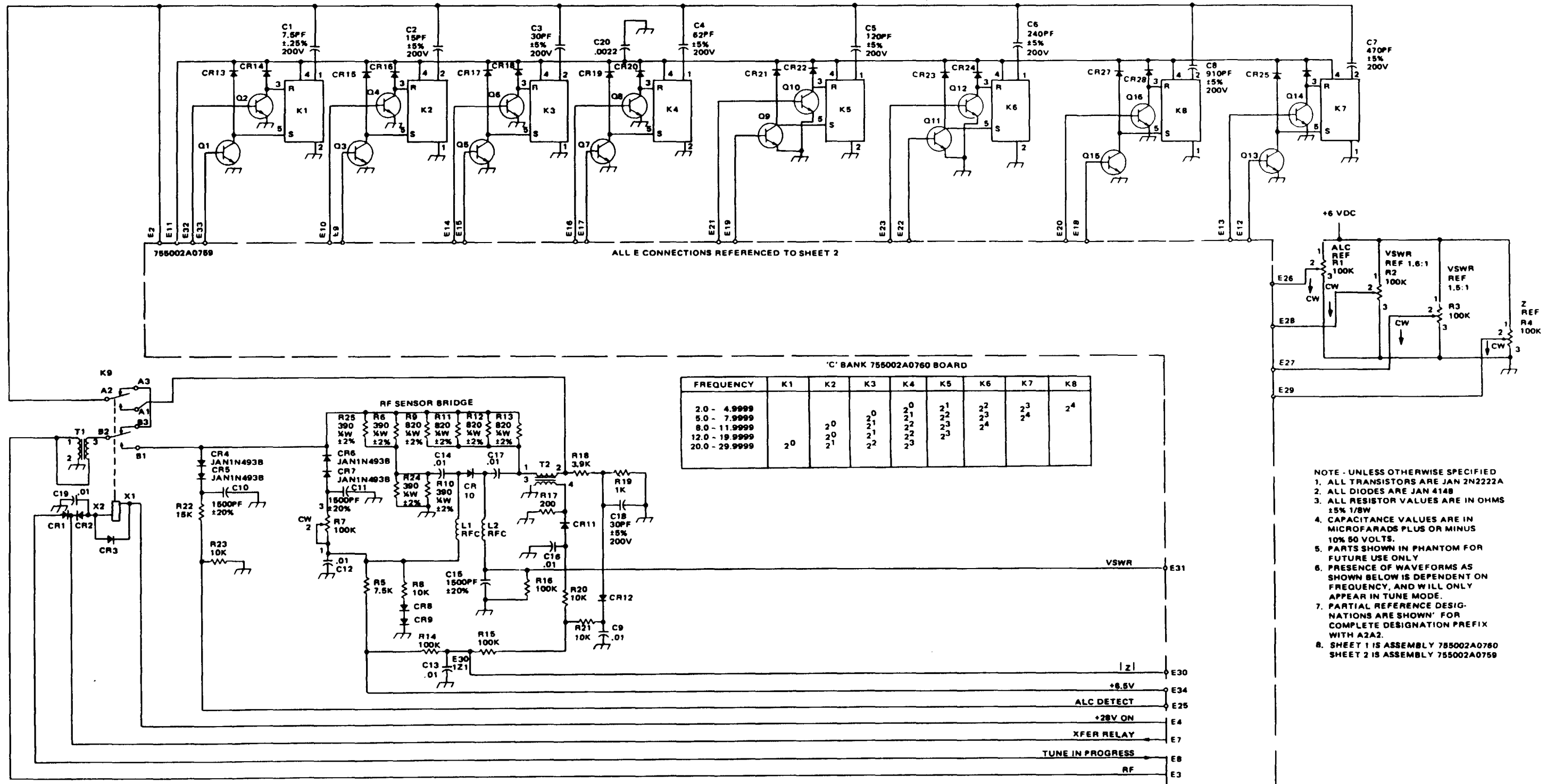
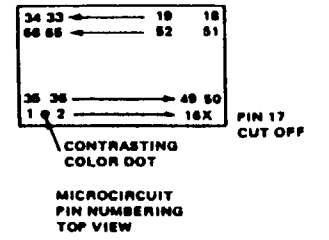
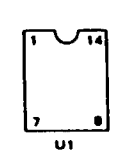

Figure 7-8. Antenna Tuner Schematic Diagram (Sheet 1)

**ANTENNA TUNER SCHEMATIC DIAGRAM (2 of 2)**

'L' BANK 755002A0759 BOARD

FREQUENCY	K1	K2	K3	K4	K5	K6	K7	K8	K9	K10	K11
2 - 2.0000				2 <sup>0</sup>	2 <sup>1</sup>	2 <sup>2</sup>	2 <sup>3</sup>	2 <sup>4</sup>	2 <sup>5</sup>	2 <sup>6</sup>	2 <sup>7</sup>
3 - 7.0000			2 <sup>0</sup>	2 <sup>1</sup>	2 <sup>2</sup>	2 <sup>3</sup>	2 <sup>4</sup>	2 <sup>5</sup>	2 <sup>6</sup>	2 <sup>7</sup>	2 <sup>8</sup>
8 - 11.0000		2 <sup>0</sup>	2 <sup>1</sup>	2 <sup>2</sup>	2 <sup>3</sup>	2 <sup>4</sup>	2 <sup>5</sup>	2 <sup>6</sup>	2 <sup>7</sup>	2 <sup>8</sup>	2 <sup>9</sup>
12 - 20.0000	2 <sup>0</sup>	2 <sup>1</sup>	2 <sup>2</sup>	2 <sup>3</sup>	2 <sup>4</sup>	2 <sup>5</sup>	2 <sup>6</sup>	2 <sup>7</sup>	2 <sup>8</sup>	2 <sup>9</sup>	2 <sup>10</sup>



ALL E CONNECTIONS REFERENCED TO SHEET 1

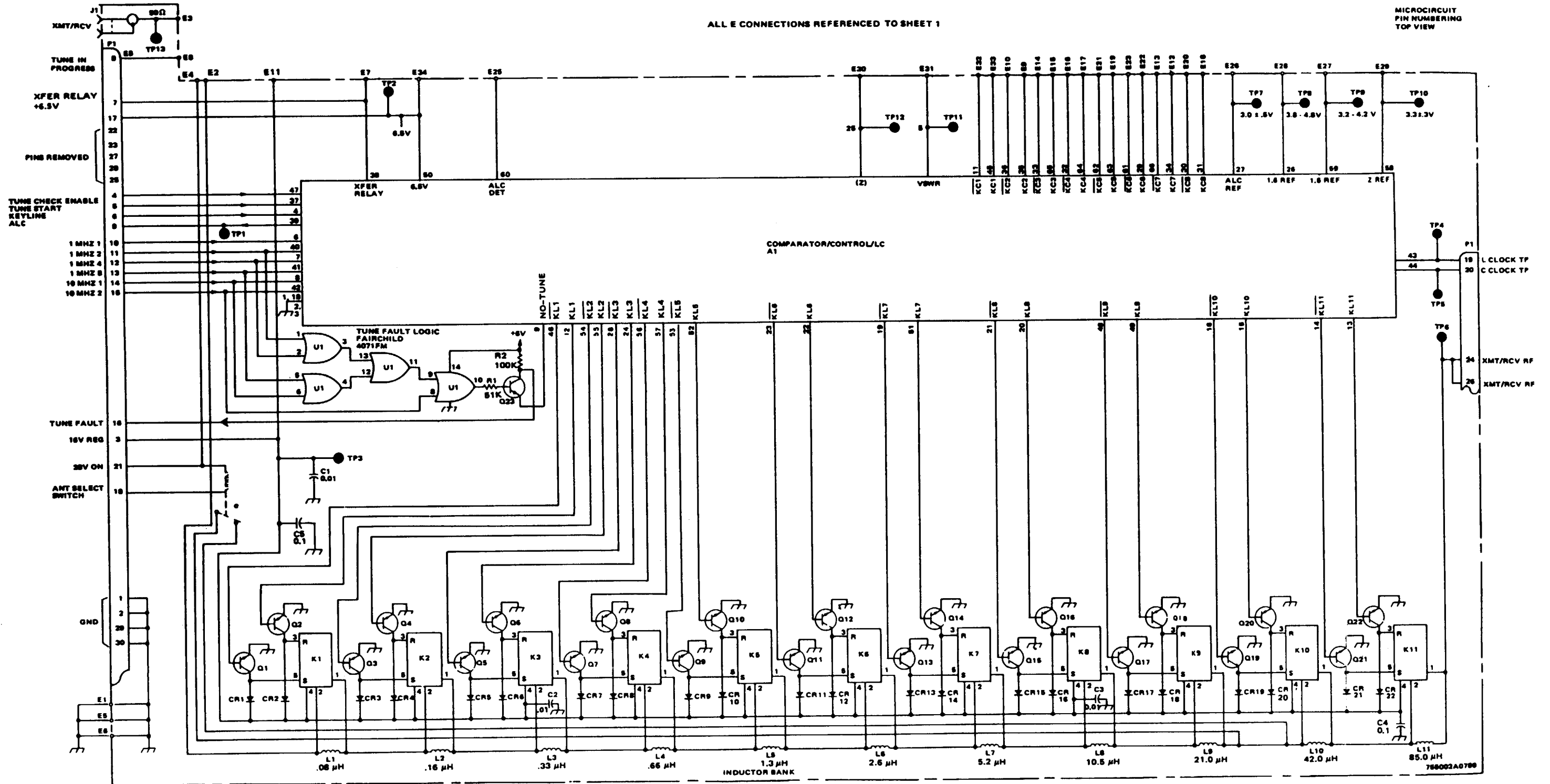

Figure 7-8. Antenna Tuner Schematic Diagram (Sheet 2)



**GLOSSARY**

**Section 1. ABBREVIATIONS**

Term or Abbreviation	Definition or Description
AGC	Automatic gain control
ALC	Automatic level control
ANT	Antenna
ANT SEL	Antenna select
bps	Bits per second
CAGE	Commercial and government entity
CCA	Circuit card assembly
C1A	Control Interface Assembly
CONT	Controller
CW	Continuous wave
D/A	Digital-to-analog
dc	Direct current
DMM	Digital Multimeter
D RCV	Data receive
DTR	Data transceiver (transmit/receive)
ECCM	Electronic counter countermeasures
EFP	Electronic front panel
EIR	Equipment improvement recommendation
ESD	Electro-static discharge
FET	Field effect transistor
GND	Ground
hf	High frequency
if.	Intermediate frequencies
LC	inductance-capacitance
LCD	Liquid crystal display
LO	Local oscillator
LSB	Lower sideband

Term or Abbreviation	Definition or Description
MAC	Maintenance allocation chart
MAX	Maximum
MHZ	One million Hertz
MOSFET	Metal oxide semiconductor field effect transistor
NVIS	Near vertical incidence skywave
PLL	Phase-locked loop
PMCS	Preventive Maintenance Checks and Services
PTT	Push-to-talk
RPSTL	Repair parts and special tools list
rf	Radio frequency
RT	Receiver-Transmitter
SEL	Select
STAJ	Short term antijam
swr	Standing wave ratio
TCXO	Temperature-compensated crystal oscillator
TMDE	Test measurement and diagnostic equipment
TTL	Transistor-transistor logic
USB	Upper sideband
U/M	Unit of measure
UUT	Unit under test
v	volt
VCO	Voltage controlled oscillator
VOGAD	Voice-operated gain adjustment device
V RCV	Voice receive
vswr	Voltage standing wave ratio
VTR	Voice transceiver (transmit/receive)
VTVM	Vacuum tube voltmeter
w	Watt
wpm	Words per minute

BLANK  
INTENTIONALLY

## APPENDIX A REFERENCES

### **SCOPE**

This appendix lists all forms, field manuals, technical manuals, and miscellaneous publications referenced in this manual.

### **FORMS**

<p>DA Form 2028 DA Form 2028-2 SF 361 SF 368</p>	<p>Recommended Changes to Publications and Blank Forms Recommended Changes to Equipment Technical Publications Discrepancy in Shipment Report (DISREP) Quality Deficiency Report</p>
--	--

### **TECHNICAL MANUALS**

<p>TM-740-90-1</p>	<p>Transportation Discrepancy Report</p>
<p>TM 750-244-2</p>	<p>Procedures for Destruction of Army Electronic Material to Prevent Enemy Use (Electronic Command)</p>
<p>TM 07748B-12/1 TM 11-5820-1046-12</p>	<p>Operator's and Organizational Maintenance Manual, Radio Set AN/PRC-104</p>
<p>RS 07748A-50/4</p>	<p>Rebuild Standard for Radio Set AN/PRC-104B</p>
<p>TM 11-5820-1046-40P</p>	<p>intermediate General Support Repair Parts and Special Tools List for Radio Set AN/PRC-104</p>
<p>SL-4-07748A TO 31R2-2PRC-104-4</p>	<p>Stock List</p>
<p>TC 10-19</p>	<p>ALICE (All-Purpose Lightweight individual Carrying Equipment)</p>
<p>TM-07508A-14</p>	<p>Antenna AS-2259JGR and Antenna-to-Antenna Base Adapter MX-9313/GR</p>

BLANK  
INTENTIONALLY

INDEX (1 of 3)

	Page		Page
<b>A</b>		<b>C (cont)</b>	
Amplifier/Coupler		Converter, 5-MHz .....	2-31
Component Location .....	7-17	<b>D</b>	
Depot Maintenance .....		Detailed Functional Description .....	2-9
Detailed Functional Description .....	2-10	<b>E</b>	
Antenna Tuner .....	2-14	<b>EFP</b>	
Power Amplifier .....	2-10	Component Location .....	6-46
Disassembly and Reassembly .....	5-7	Fault isolation .....	6-2
Fault Isolation .....	7-1	Performance Test .....	6-3
Introduction and Tools .....	5-1	Performance Test Setup .....	6-2
Maintenance .....	5-1	Special Tools and Test Equipment .....	6-2
Power Distribution .....	5-4	Schematic Diagram .....	6-60
RF Cabling .....	5-4	Electronic Front Panel (EFP) A1A4 Removal and Replacement .....	4-12
Schematic Diagrams .....	7-23	Equipment Description and Data .....	1-3
Special Tools .....	5-1	Equipment Not Supplied .....	1-6
Test Equipment .....	5-1	Equipment Supplied .....	1-5
TroubelShooting .....	5-3	Examination .....	3-15
Troubleshooting Procedure .....	5-6	<b>F</b>	
Antenna Base .....	3-28	Fabrication of Special Support Equipment .....	3-17
Antenna Mount .....	5-12	First Frequency Converter	
Antenna Select Switch A2S1 .....	5-13	Component Location .....	6-51
Antenna Tuner		Fault Isolation .....	6-19
A2A2 Removal and Replacement .....	5-9	Performance Test .....	6-20
Component Location .....	7-20	Performance Test Setup .....	6-19
Fault Isolation .....	7-8	Special Tools and Test Equipment .....	6-19
Alignment Procedure .....	7-10	Schematic Diagram .....	6-78
Performance Test .....	7-9	Front Panel Assembly .....	2-16
Performance Test Setup .....	7-8	<b>G</b>	
Special Tools and Test Equipment .....	7-27	General Information .....	1-1
Schematic Diagram .....	7-27	General Maintenance .....	3-1
Audio Filter Assembly .....	2-25	Ground A2E1 Removal and Replacement .....	5-14
<b>B</b>		<b>H</b>	
Battery Extender Cable .....	3-27	Harmonic Filter	
Bench Test Cable .....	3-26	A1A2 Removal and Replacement .....	4-10
BNC Connector A2J1 .....	5-12	Component Location .....	6-54
<b>C</b>		Fault Isolation .....	6-31
Cable W2 .....	4-14	Alignment Procedure .....	6-36
Cable W3 .....	4-15	Performance Test .....	6-32
Cable W4 .....	4-15	Performance Test Setup .....	6-31
Cable W5 .....	4-16	Special Tools and Test Equipment .....	6-31
Cable W6 .....	4-17	Schematic Diagram .....	6-81
Cable W1P2 .....	4-18		
Circuit Card			
Assembly Repair Procedures (Marine Corps Only) .....	3-1		
Repair Procedures .....	3-4		
Standards .....	3-2		
Cleaning and Examlnation .....	3-13		
Cleaning .....	3-14		
Examination .....	3-15		
Control Interface Assembly .....	2-18		

**INDEX (2 of 3)**

	Page		Page
<b>I</b>			
Introduction .....	1-1		
<b>L</b>			
Latch Removal and Replacement .....	5-15		
List of Publications .....	1-7		
<b>M</b>			
Maintenance Data for Accessories .....	3-25		
Modulator/Demodulator	4-9		
AI AI Removal and Replacement .....	6-50		
Component Location .....	6-8		
Fault Isolation .....	6-8		
Alignment Procedure .....	6-8		
Performance Test .....	6-10		
Performance Test Setup .....	6-9		
Special Tools and Test Equipment .....	6-8		
Schematic Diagram .....	6-76		
Oscillator, 70/80 MHz Voltage-Controiied .....	2-30		
Schematic Diagram .....	6-72		
Oscillator, 77-105 MHz Voltaga-Controiied .....	2-30		
Schematic Diagram .....	6-74		
<b>P</b>			
Performance Test and Troubleshooting .....	3-22		
Power Amplifier	5-8		
A2A1 Removal and Replacement .....	7-18		
Component Location .....	7-1		
Fault Isolation .....	7-7		
Alignment Procedure .....	7-3		
Performance Test .....	7-2		
Performance Test Setup .....	7-1		
Special Tools and Test Equipment .....	7-24		
Schematic Diagram .....	2-53		
Power Distribution .....	2-53		
Description .....	2-53		
Power Supply	4-13		
A1A5 Removal and Replacement .....	6-55		
Component Location .....	6-39		
Fault Isolation .....	6-43		
Alignment Procedure .....	6-41		
Performance Test .....	6-40		
Performance Test Setup .....	6-39		
Special Tools and Test Equipment .....	6-82		
Schematic Diagram .....	2-1		
principles of Operation .....	2-1		
<b>R</b>			
Radio Set	1-3		
Description .....	2-5		
General Description .....	2-5		
<b>R (cont)</b>			
Ramp Generator .....			2-31
Schematic Diagram .....			6-70
Receive Operation .....			2-4
Ribbon Cable A2W1 Removal and Replacement .....			5-10
<b>RT</b>			
Component Location .....			6-45
Depot Maintenance .....			6-1
Detailed Functional Description .....			2-16
Audio Control Hybrid .....			2-28
Automatic Level Control .....			2-34
Electronic Front Panel .....			2-16
Frequency Converters .....			2-36
Harmonic Filter .....			2-42
Modulator/Demoduiator .....			2-26
Power Supply .....			2-50
Synthesizer .....			2-22
Disassembly and Reassembly .....			4-7
Fault Isolation .....			6-1
Housing Assembly Removal and Replacement .....			4-8
Maintenance .....			4-1
Schematic Diagrams .....			6-57
Special Tools .....			4-1
Test Equipment .....			4-1
Tools and Test Equipment .....			4-1
Troubleshooting .....			4-3
Procedure .....			4-4
RT, Ampiiifier/Coupler, and Battery Pack General Description .....			2-6
<b>S</b>			
Safety Summary .....			a
Scope of Manual .....			1-1
Second Frequency Converter			6-52
Component Location .....			6-25
Fault Isolation .....			6-22
Performance Test .....			6-25
Performance Test Setup .....			6-25
Special Tools and Test Equipment .....			6-79
Schematic Diagram .....			1-6
Support Equipment .....			1-6
<b>Synthesizer</b>			
A1A3 Removal and Replacement .....			4-11
Component Location .....			6-53
Fault Isolation .....			6-25
Alignment Procedure .....			6-30
Performance Test .....			6-26
Performance Test Setup .....			6-25
Special Tools and Test Equipment .....			6-25
Schematic Diagram .....			6-65

**INDEX (3 of 3)**

<b>T</b>		<b>Page</b>	<b>T (cont)</b>	<b>P a g e</b>
Table of Contents .....	i			
Technical Characteristics .....	1-4			
Telegraph Key .....	3-29			
Theory of Operation .....	2-1			
Third Frequency Converter				
Component Location .....	6-53	Third Frequency Converter (cont)		
Fault Isolation .....	6-23	performance Test .....	6-24	
		Performance Test Setup .....	6-23	
		Special Tools and Test Equipment .....	6-23	
		Schematic Diagram .....	6-80	
		Transit Case .....	3-30	
		Transmit Operation .....	2-2	

BLANK  
INTENTIONALLY