

## TECHNICAL MANUAL

### MAINTENANCE INSTRUCTIONS WITH ILLUSTRATED PARTS BREAKDOWN DEPOT

### RADIO COMMUNICATION SYSTEM AN/GRC-206(V)1 PART NUMBER 707167-801 NSN 5820-01-113-1925 AND AN/GRC-206(V)2 PART NUMBER 707167-802 NSN 5820-01-075-2001

(ATOS)

DOCUMENT CLEARED FOR RELEASE VIA FOIA-2014-06235-F

**THIS DOCUMENT IS PUBLIC DOMAIN**

DISTRIBUTION STATEMENT B - Distribution authorized to U.S. Government Agencies only (Administrative or Operational Use) (30 October 1998). Other requests for this document shall be referred to 406 SCMS/GUHA, Robins AFB, GA 31098. Questions concerning technical content shall be referred to 407 SCMS/GULA.

WARNING - This document contains technical data whose export is restricted by the Arms Export Control Act (Title 22, U.S.C., Sec 2751, et seq.) or the Export Administration Act of 1979, as amended, Title 50, U.S.C., App. 2401, et seq. Violations of these export laws are subject to severe criminal penalties. Disseminate in accordance with provisions of DoD Directive 5230.25.

HANDLING AND DESTRUCTION NOTICE - Comply with distribution statement and destroy by any method that will prevent disclosure of contents or reconstruction of the document.

BASIC AND ALL CHANGES HAVE BEEN MERGED  
TO MAKE THIS A COMPLETE PUBLICATION

Published Under Authority of the Secretary of the Air Force

INSERT LATEST CHANGED PAGES. DESTROY SUPERSEDED PAGES.

**LIST OF EFFECTIVE PAGES**

NOTE: The portion of the text affected by the changes is indicated by a vertical line in the outer margin of the page. Changes to illustrations are indicated by shaded or screened areas, or by miniature pointing hands.

Dates of issue for original and changed pages are:

|  |  |
|--|--|
| Original . . . . .0 . . . . .15 January 1987 | Change . . . . .5 . . . . .5 November 1999 |
| Change . . . . .1 . . . . .30 July 1991      | Change . . . . .6 . . . . .30 May 2000     |
| Change . . . . .2 . . . . .28 February 1992  | Change . . . . .7 . . . . .20 October 2000 |
| Change . . . . .3 . . . . .7 January 1993    | Change . . . . .8 . . . . .1 May 2002      |
| Change . . . . .4 . . . . .30 October 1998   | Change . . . . .9 . . . . .22 June 2009    |

TOTAL NUMBER OF PAGES IN THIS PUBLICATION IS 624, CONSISTING OF THE FOLLOWING:

| Page No.                        | *Change No. | Page No.                | *Change No. | Page No.                    | *Change No. |
|---------------------------------|-------------|-------------------------|-------------|-----------------------------|-------------|
| Title . . . . .                 | 9           | 7-14.1 Added . . . . .  | 2           | Index 1 - Index 8 . . . . . | 0           |
| A - B . . . . .                 | 9           | 7-14.2 Blank . . . . .  | 2           | FO-1 . . . . .              | 0           |
| C Blank . . . . .               | 6           | 7-15 - 7-16 . . . . .   | 0           | FO-2 Blank . . . . .        | 0           |
| i - ii . . . . .                | 0           | 7-17 . . . . .          | 9           | FO-3 . . . . .              | 0           |
| iii - viii . . . . .            | 9           | 7-18 - 7-42 . . . . .   | 0           | FO-4 Blank . . . . .        | 0           |
| ix . . . . .                    | 0           | 7-43 . . . . .          | 9           | FO-5 . . . . .              | 0           |
| x Blank . . . . .               | 0           | 7-44 - 7-46 . . . . .   | 0           | FO-6 Blank . . . . .        | 0           |
| 1-1 - 1-26 . . . . .            | 0           | 7-47 - 7-48 . . . . .   | 4           | FO-7 . . . . .              | 0           |
| 2-1/3-1 - 3-8 . . . . .         | 0           | 7-49 - 7-50 . . . . .   | 0           | FO-8 Blank . . . . .        | 0           |
| 4-1 - 4-58 . . . . .            | 0           | 7-51 . . . . .          | 9           | FO-9 . . . . .              | 0           |
| 5-1 - 5-2 . . . . .             | 4           | 7-52 . . . . .          | 4           | FO-10 Blank . . . . .       | 0           |
| 5-3 - 5-96 . . . . .            | 0           | 7-53 - 7-54 . . . . .   | 0           | FO-11 . . . . .             | 0           |
| 5-97 - 5-102 . . . . .          | 7           | 7-55 . . . . .          | 3           | FO-12 Blank . . . . .       | 0           |
| 5-103 - 5-104 Deleted . . . . . | 7           | 7-56 - 7-57 . . . . .   | 0           | FO-13 . . . . .             | 0           |
| 5-105 - 5-106 . . . . .         | 0           | 7-58 . . . . .          | 9           | FO-14 Blank . . . . .       | 0           |
| 5-107 - 5-108 . . . . .         | 7           | 7-59 - 7-63 . . . . .   | 0           | FO-15 . . . . .             | 0           |
| 5-109 - 5-110 . . . . .         | 6           | 7-64 . . . . .          | 9           | FO-16 Blank . . . . .       | 0           |
| 5-111 - 5-113 . . . . .         | 7           | 7-65 . . . . .          | 0           | FO-17 . . . . .             | 0           |
| 5-114 Blank . . . . .           | 7           | 7-66 . . . . .          | 9           | FO-18 Blank . . . . .       | 0           |
| 5-115 - 5-120 . . . . .         | 0           | 7-67 . . . . .          | 0           | FO-19 . . . . .             | 0           |
| 5-121 - 5-122 . . . . .         | 7           | 7-68 . . . . .          | 9           | FO-20 Blank . . . . .       | 0           |
| 5-123 - 5-128 . . . . .         | 0           | 7-69 - 7-90 . . . . .   | 0           | FO-21 . . . . .             | 0           |
| 5-129 - 5-131 . . . . .         | 7           | 7-91 - 7-92 . . . . .   | 8           | FO-22 Blank . . . . .       | 0           |
| 5-132 Blank . . . . .           | 7           | 7-93 - 7-99 . . . . .   | 0           | FO-23 . . . . .             | 0           |
| 5-133 - 5-138 . . . . .         | 0           | 7-100 . . . . .         | 2           | FO-24 Blank . . . . .       | 0           |
| 5-139 - 5-142 . . . . .         | 7           | 7-101 - 7-105 . . . . . | 0           | FO-25 . . . . .             | 0           |
| 5-143 - 5-158 . . . . .         | 0           | 7-106 . . . . .         | 9           | FO-26 Blank . . . . .       | 0           |
| 5-159 - 5-162 . . . . .         | 5           | 7-106.1 Added . . . . . | 2           | FO-27 . . . . .             | 0           |
| 5-163 - 5-184 . . . . .         | 0           | 7-106.2 Blank . . . . . | 2           | FO-28 Blank . . . . .       | 0           |
| 5-185 - 5-186 . . . . .         | 8           | 7-107 - 7-108 . . . . . | 7           | FO-29 . . . . .             | 0           |
| 5-187 - 5-196 . . . . .         | 0           | 7-109 - 7-112 . . . . . | 0           | FO-30 Blank . . . . .       | 0           |
| 6-1 . . . . .                   | 0           | 7-113 . . . . .         | 9           | FO-31 . . . . .             | 0           |
| 6-2 Blank . . . . .             | 0           | 7-114 - 7-115 . . . . . | 0           | FO-32 Blank . . . . .       | 0           |
| 7-1 - 7-7 . . . . .             | 0           | 7-116 . . . . .         | 1           | FO-33 . . . . .             | 0           |
| 7-8 . . . . .                   | 2           | 7-117 . . . . .         | 3           | FO-34 Blank . . . . .       | 0           |
| 7-9 - 7-12 . . . . .            | 0           | 7-118 - 7-120 . . . . . | 0           | FO-35 . . . . .             | 0           |
| 7-13 . . . . .                  | 9           | 7-121 - 7-124 . . . . . | 8           | FO-36 Blank . . . . .       | 0           |
| 7-14 . . . . .                  | 3           | 7-125 - 7-136 . . . . . | 0           | FO-37 . . . . .             | 0           |

\*Zero in this column indicates an original page.



| Page No.    | *Change No. | Page No.     | *Change No. | Page No.     | *Change No. |
|-------------|-------------|--------------|-------------|--------------|-------------|
| FO-38 Blank | 0           | FO-95        | 0           | FO-140 Blank | 0           |
| FO-39       | 0           | FO-96 Blank  | 0           | FO-141       | 0           |
| FO-40 Blank | 0           | FO-97        | 0           | FO-142 Blank | 0           |
| FO-41       | 0           | FO-98 Blank  | 0           | FO-143       | 0           |
| FO-42 Blank | 0           | FO-99        | 0           | FO-144 Blank | 0           |
| FO-43       | 0           | FO-100 Blank | 0           | FO-145       | 0           |
| FO-44 Blank | 0           | FO-101       | 0           | FO-146 Blank | 0           |
| FO-45       | 0           | FO-102 Blank | 0           | FO-147       | 0           |
| FO-46 Blank | 0           | FO-103       | 0           | FO-148 Blank | 0           |
| FO-47       | 0           | FO-104 Blank | 0           | FO-149       | 0           |
| FO-48 Blank | 0           | FO-105       | 0           | FO-150 Blank | 0           |
| FO-49       | 0           | FO-106 Blank | 0           | FO-151       | 0           |
| FO-50 Blank | 0           | FO-107       | 0           | FO-152 Blank | 0           |
| FO-51       | 0           | FO-108 Blank | 0           | FO-153       | 0           |
| FO-52 Blank | 0           | FO-109       | 0           | FO-154 Blank | 0           |
| FO-53       | 0           | FO-110 Blank | 0           | FO-155       | 0           |
| FO-54 Blank | 0           | FO-111       | 0           | FO-156 Blank | 0           |
| FO-55       | 0           | FO-112 Blank | 0           | FO-157       | 0           |
| FO-56 Blank | 0           | FO-113       | 0           | FO-158 Blank | 0           |
| FO-57       | 0           | FO-114 Blank | 0           | FO-159       | 0           |
| FO-58 Blank | 0           | FO-115       | 0           | FO-160 Blank | 0           |
| FO-59       | 0           | FO-116 Blank | 0           | FO-161       | 0           |
| FO-60 Blank | 0           | FO-117       | 0           | FO-162 Blank | 0           |
| FO-61       | 0           | FO-118 Blank | 0           | FO-163       | 0           |
| FO-62 Blank | 0           | FO-119       | 0           | FO-164 Blank | 0           |
| FO-63       | 0           | FO-120 Blank | 0           | FO-165       | 0           |
| FO-64 Blank | 0           | FO-121       | 0           | FO-166 Blank | 0           |
| FO-65       | 0           | FO-122 Blank | 0           | FO-167       | 0           |
| FO-66 Blank | 0           | FO-123       | 0           | FO-168 Blank | 0           |
| FO-67       | 0           | FO-124 Blank | 0           | FO-169       | 0           |
| FO-68 Blank | 0           | FO-125       | 0           | FO-170 Blank | 0           |
| FO-69       | 0           | FO-126 Blank | 0           | FO-171       | 0           |
| FO-70 Blank | 0           | FO-127       | 0           | FO-172 Blank | 0           |
| FO-71       | 0           | FO-128 Blank | 0           | FO-173       | 0           |
| FO-72 Blank | 0           | FO-129       | 0           | FO-174 Blank | 0           |
| FO-73       | 0           | FO-130 Blank | 0           |              |             |
| FO-74 Blank | 0           | FO-131       | 0           |              |             |
| FO-75       | 0           | FO-132 Blank | 0           |              |             |
| FO-76 Blank | 0           | FO-133       | 0           |              |             |
| FO-77       | 0           | FO-134 Blank | 0           |              |             |
| FO-78 Blank | 0           | FO-135       | 0           |              |             |
| FO-79       | 0           | FO-136 Blank | 0           |              |             |
| FO-80 Blank | 0           | FO-125       | 0           |              |             |
| FO-81       | 0           | FO-126 Blank | 0           |              |             |
| FO-82 Blank | 0           | FO-127       | 0           |              |             |
| FO-83       | 0           | FO-128 Blank | 0           |              |             |
| FO-84 Blank | 0           | FO-129       | 0           |              |             |
| FO-85       | 0           | FO-130 Blank | 0           |              |             |
| FO-86 Blank | 0           | FO-131       | 0           |              |             |
| FO-87       | 0           | FO-132 Blank | 0           |              |             |
| FO-88 Blank | 0           | FO-133       | 0           |              |             |
| FO-89       | 0           | FO-134 Blank | 0           |              |             |
| FO-90 Blank | 0           | FO-135       | 0           |              |             |
| FO-91       | 0           | FO-136 Blank | 0           |              |             |
| FO-92 Blank | 0           | FO-137       | 0           |              |             |
| FO-93       | 0           | FO-138 Blank | 0           |              |             |
| FO-94 Blank | 0           | FO-139       | 0           |              |             |

\*Zero in this column indicates an original page.



SAFETY SUMMARY

The following warnings and cautions appear in the text in this volume, and are repeated here for emphasis.

WARNING

High voltages capable of causing death are used in this equipment. Use extreme caution when servicing either the power supplies or their load components.

CAUTION

Prior to handling electrostatic-sensitive electronic devices, personnel and equipment must be grounded to prevent static discharge damage to the device. Do not removal or install subassembly in test fixture with power applied or damage to equipment may result.

Do not attempt to install both audio interface circuit cards in the card guides on the test set at the same time, or damage to equipment may result.

CAUTION

Set all test equipment switches to the OFF or down position to begin the procedure.

CAUTION

The following steps reads a negative value. Ensure that test equipment is configured to read negative values or damage may result to the equipment.

CAUTION

Fibers of fiber optic cable are very delicate. Fibers will break if roughly handled.

CAUTION

Ensure S12 is held in BAT PLRT RVS position only momentarily or damage to equipment may result.

CAUTION

Ensure insulated leads are used to prevent shorting of +28 VC power supply.

CAUTION

The top of Power Converter Test Set TS4090 will be hot to the touch. Ensure the top remains clear for cooling purposes.

CAUTION

Ensure power and signal inputs are removed before doing continuity checks. Otherwise, damage to equipment may result.

## TABLE OF CONTENTS

| Chapter |  | Page    |
|---------|--|---------|
| 1.      | GENERAL INFORMATION                            |         |
| 1-1     | GENERAL .....                                  | 1-1     |
| 1-2     | DESCRIPTION AND PURPOSE.....                   | 1-1     |
| 1-3     | ELECTRICAL DESCRIPTION .....                   | 1-1     |
| 1-4     | PHYSICAL DESCRIPTION .....                     | 1-1     |
| 1-5     | RADIO SYSTEM .....                             | 1-9     |
| 1-6     | EQUIPMENT MOUNTING RACK.....                   | 1-9     |
| 1-7     | POWER SWITCHBOARD .....                        | 1-9     |
| 1-8     | SIGNAL DISTRIBUTION UNIT.....                  | 1-9     |
| 1-9     | RADIO SET CONTROL .....                        | 1-9     |
| 1-10    | HF SUBSYSTEM .....                             | 1-10    |
| 1-11    | VHF-FM SUBSYSTEM .....                         | 1-10    |
| 1-12    | VHF-AM SUBSYSTEM .....                         | 1-10    |
| 1-13    | UHF-AM SUBSYSTEM .....                         | 1-10    |
| 1-14    | ANTENNA SYSTEMS .....                          | 1-10    |
| 1-15    | ACCESSORY AND ANCILLARY EQUIPMENT .....        | 1-11    |
| 1-16    | COMSEC EQUIPMENT COMPATIBILITY .....           | 1-11    |
| 1-17    | LEADING PARTICULARS.....                       | 1-11    |
| 1-18    | CAPABILITIES AND LIMITATIONS .....             | 1-15    |
| 1-19    | EQUIPMENT SUPPLIED.....                        | 1-16    |
| 1-20    | EQUIPMENT REQUIRED BUT NOT SUPPLIED.....       | 1-16    |
| 1-21    | SPECIAL TOOLS AND TEST EQUIPMENT .....         | 1-16    |
| 1-22    | RELATED TECHNICAL MANUALS .....                | 1-20    |
| 2.      | INSTALLATION                                   |         |
| 2-1     | GENERAL .....                                  | 2-1/3-1 |
| 3.      | PREPARATION FOR USE AND RESHIPMENT             |         |
| 3-1     | INTRODUCTION.....                              | 2-1/3-1 |
| 3-2     | GENERAL .....                                  | 2-1/3-1 |
| 3-3     | PREPARATION FOR RESHIPMENT .....               | 2-1/3-1 |
| 4.      | THEORY OF OPERATION                            |         |
| 4-1     | INTRODUCTION.....                              | 4-1     |
|         | SECTION I. FUNCTIONAL SYSTEM OPERATION .....   | 4-1     |
| 4-2     | GENERAL .....                                  | 4-1     |
| 4-3     | RADIO SYSTEM FUNCTIONAL DESCRIPTION.....       | 4-1     |
|         | SECTION II. DETAILED THEORY OF OPERATION ..... | 4-5     |
| 4-4     | SCOPE .....                                    | 4-5     |
| 4-5     | ELECTRICAL EQUIPMENT CHASSIS.....              | 4-5     |
| 4-6     | SDU AUDIO INTERFACE (1) CCA .....              | 4-6     |
| 4-7     | SDU AUDIO INTERFACE (2) CCA.....               | 4-10    |
| 4-8     | RED INTERFACE CCA.....                         | 4-12    |
| 4-9     | BLACK INTERFACE CCA .....                      | 4-18    |
| 4-10    | CPU CCA.....                                   | 4-26    |
| 4-11    | SDU POWER SUPPLY SUBASSEMBLY.....              | 4-33    |
| 4-12    | FIBER OPTIC MODULE ASSEMBLY .....              | 4-35    |

## TABLE OF CONTENTS - CONTINUED

| CHAPTER      |  | PAGE  |
|--------------|--|-------|
| 4-13         | RADIO SET CONTROL .....                            | 4-37  |
| 4-14         | AUDIO INTERFACE CCA .....                          | 4-37  |
| 4-15         | DIGITAL INTERFACE CCA .....                        | 4-43  |
| 4-16         | RSC REGULATOR .....                                | 4-48  |
| 4-17         | FM BITE/AUDIO INTERFACE ASSEMBLY .....             | 4-49  |
| 4-18         | PANEL INTERFACE CCA .....                          | 4-51  |
| 4-19         | SDU INTERFACE CCA .....                            | 4-55  |
| 4-20         | RT INTERFACE CCA .....                             | 4-56  |
| 5.           | MAINTENANCE  |       |
| 5-1          | SCOPE .....  | 5-1   |
| SECTION I.   | SPECIAL MAINTENANCE .....                          | 5-1   |
| 5-2          | GENERAL .....                                      | 5-1   |
| 5-3          | SDU ELECTRICAL EQUIPMENT CHASSIS MAINTENANCE ..... | 5-2   |
| 5-4          | AUDIO INTERFACE (1) MAINTENANCE .....              | 5-10  |
| 5-5          | AUDIO INTERFACE (2) MAINTENANCE .....              | 5-45  |
| 5-6          | SDU POWER SUPPLY SUBASSEMBLY MAINTENANCE .....     | 5-48  |
| 5-7          | FIBER OPTIC MODULE ASSEMBLY MAINTENANCE .....      | 5-64  |
| 5-8          | FIBER OPTIC CABLE ASSEMBLY .....                   | 5-68  |
| 5-9          | RADIO SET CONTROL .....                            | 5-85  |
| 5-10         | RSC AUDIO INTERFACE CCA .....                      | 5-148 |
| 5-11         | RSC DIGITAL INTERFACE CCA .....                    | 5-152 |
| 5-12         | RSC REGULATOR CCA .....                            | 5-156 |
| 5-13         | FM BITE/AUDIO INTERFACE ASSEMBLY .....             | 5-164 |
| 5-14         | FM BITE/AUDIO CCA .....                            | 5-179 |
| 5-15         | DISTRIBUTION BOX MAINTENANCE .....                 | 5-180 |
| 5-16         | PDU ELECTRICAL EQUIPMENT CHASSIS MAINTENANCE ..... | 5-184 |
| SECTION II.  | PERFORMANCE TEST CHECKS .....                      | 5-185 |
| 5-17         | GENERAL .....                                      | 5-185 |
| 6.           | CIRCUIT DIAGRAMS                                   |       |
| 6-1          | GENERAL .....                                      | 6-1   |
| 7.           | ILLUSTRATED PARTS BREAKDOWN                        |       |
| SECTION I.   | INTRODUCTION .....                                 | 7-1   |
| 7-1          | GENERAL .....                                      | 7-1   |
| 7-2          | MAINTENANCE PARTS LIST .....                       | 7-1   |
| 7-3          | NUMERICAL INDEX .....                              | 7-3   |
| 7-4          | REFERENCE DESIGNATION INDEX .....                  | 7-4   |
| SECTION II.  | MAINTENANCE PARTS LIST .....                       | 7-7   |
| SECTION III. | NUMERIC INDEX .....                                | 7-116 |
| SECTION IV.  | REFERENCE DESIGNATION INDEX .....                  | 7-125 |

## LIST OF ILLUSTRATIONS

| Figure | Title   | Page |
|--------|---|------|
| 1-1    | Radio Communication System AN/GRC-206(V)1 (Sheet 1 of 2) .....      | 1-2  |
| 1-1    | Radio Communication System AN/GRC-205(V)2 (Sheet 2) .....           | 1-3  |
| 1-2    | Radio System Component Location .....                               | 1-4  |
| 1-3    | Radio System Antennas .....   | 1-12 |
| 1-4    | TS-4132 SDU Test Set Controls, Indicators and Connectors .....      | 1-19 |
| 3-1    | Component Packing and Unpacking .....                               | 3-4  |
| 3-2    | Assembly Packing and Unpacking .....                                | 3-5  |
| 3-3    | Typical Packing Instructions for Mechanical Items .....             | 3-7  |
| 3-4    | Typical Packing Instructions for Antennas and Cables .....          | 3-8  |
| 4-1    | Radio System Simplified Block Diagram .....                         | 4-2  |
| 4-2    | SDU Audio Interface (1) 1A1 and (2) 1A2 Block Diagram .....         | 4-7  |
| 4-3    | SDU Red Interface CCA 1A3 Block Diagram .....                       | 4-14 |
| 4-4    | Red Interface Basic Mode Definitions and Bus Interface .....        | 4-17 |
| 4-5    | SDU Black Interface CCA 1A4 Block Diagram .....                     | 4-20 |
| 4-6    | Black Interface Basic Mode Definitions and Bus Interface .....      | 4-22 |
| 4-7    | PIC Block Diagram .....   | 4-34 |
| 4-8    | SDU Power Supply Subassembly 1A6 Block Diagram .....                | 4-36 |
| 4-9    | RSC-SDU Communication Word Format .....                             | 4-39 |
| 4-10   | RSC Transmit Audio 5A2A2 or 6A2A2 Block Diagram .....               | 4-40 |
| 4-11   | RSC Receive Audio 5A2A2 or 6A2A2 Block Diagram .....                | 4-42 |
| 4-12   | Digital Interface CCA 5A2A1 or 6A2A1 Block Diagram .....            | 4-45 |
| 4-13   | RSC Keyboard Schematic Diagram .....                                | 4-46 |
| 4-14   | VHF BITE Panel 4A1 Block Diagram .....                              | 4-52 |
| 4-15   | Panel Interface CCA Block Diagram .....                             | 4-54 |
| 4-16   | SDU Interface CCA Block Diagram .....                               | 4-57 |
| 4-17   | RT Interface CCA Block Diagram .....                                | 4-58 |
| 5-1    | SDU Electrical Equipment Chassis 1 Bench Test Setup .....           | 5-3  |
| 5-1.1  | SDU Reference Designator Location .....                             | 5-9  |
| 5-2    | SDU CCAs Bench Test Setup .....                                     | 5-11 |
| 5-3    | Audio Interface (1) 1A1 Component Location .....                    | 5-13 |
| 5-4    | Audio Interface (2) 1A2 Component Location .....                    | 5-47 |
| 5-5    | SDU Power Supply 1A6 Bench Test Setup .....                         | 5-49 |
| 5-6    | SDU Power Supply 1A6 Component Location .....                       | 5-62 |
| 5-7    | SDU Power Supply 1A6 Component Height .....                         | 5-63 |
| 5-8    | Fiber Optic Module 1A8 and 1A9 Component Location .....             | 5-65 |
| 5-9    | Fiber Optic Transmitter CCA 1A8A1 or 1A9A1 Component Location ..... | 5-66 |
| 5-10   | Fiber Optic Receiver CCA 1A8A2 or 1A9A2 Component Location .....    | 5-67 |
| 5-11   | Fiber Optic Cable Assembly 1A8 or 1A9 Bench Test Setup .....        | 5-70 |
| 5-12   | Hermaphroditic Connector Components .....                           | 5-72 |
| 5-12.1 | Fiber Optic Cable Assembly 1A8 or 1A9 OTDR Display .....            | 5-77 |
| 5-12.2 | Single and Dual OTDR Test Setups .....                              | 5-78 |
| 5-13   | RSC CCAs Bench Test Setup .....                                     | 5-88 |

## LIST OF ILLUSTRATIONS - Continued

| Number | Title   | Page  |
|--------|---|-------|
| 5-14   | Radio Set Control Component Location .....                        | 5-90  |
| 5-14.1 | Display Segment Identification .....                              | 5-145 |
| 5-15   | RSC Audio Interface 5A2A2 or 6A2A2 Component Location .....       | 5-150 |
| 5-16   | RSC Digital Interface CCA 5A2A1 or 6A2A1 Component Location ..... | 5-154 |
| 5-17   | RSC Regulator CCA 5A1A1 or 6A1A1 Component Location.....          | 5-157 |
| 5-18   | RSC Regulator CCA 5A1A1 or 6A1A1 Component Location.....          | 5-163 |
| 5-19   | FM BITE/Audio Interface 4A1 Bench Test Setup .....                | 5-165 |
| 5-20   | FM BITE/Audio Interface 4A1 Component Location .....              | 5-176 |
| 5-21   | FM BITE/Audio Interface 4A1 Wiring Diagram.....                   | 5-178 |
| 5-22   | FM BITE/Audio Interface CCA 4A1A1 Component Location .....        | 5-181 |
| 5-23   | Distribution Box 4A2 Bench Test Setup .....                       | 5-182 |
| 5-24   | PDU Electrical Equipment Chassis 2 Bench Test Setup.....          | 5-186 |
| 5-25   | PDU Electrical Equipment Chassis 2 Component Location .....       | 5-195 |
| 7-1    | Radio Communication System AN/GRG-206(V)1, AN/206(V)2 .....       | 7-7   |
| 7-2    | Control Signal Distribution Unit, C-11169/GRC-206 .....           | 7-15  |
| 7-3    | Distribution Unit Cover .....                                     | 7-18  |
| 7-4    | Audio Interface Circuit Card Assembly (1) .....                   | 7-20  |
| 7-5    | Audio Interface Circuit Card Assembly (2) .....                   | 7-26  |
| 7-6    | Red Interface Circuit Card Assembly .....                         | 7-32  |
| 7-7    | Black Interface Circuit Card Assembly.....                        | 7-35  |
| 7-8    | Central Processing Unit Printed Circuit Card Assembly .....       | 7-38  |
| 7-9    | Power Supply Subassembly .....                                    | 7-41  |
| 7-10   | Backplane Assembly .....  | 7-46  |
| 7-11   | Fiber Optic Module Assembly .....                                 | 7-48  |
| 7-12   | Electrical Equipment Chassis .....                                | 7-53  |
| 7-13   | Power Switchboard, SB-4151/GRC-206.....                           | 7-56  |
| 7-14   | Mounting Plate Assembly .....                                     | 7-59  |
| 7-15   | Electrical Equipment Chassis .....                                | 7-61  |
| 7-16   | Radio Set, AN/URC-113 .....                                       | 7-65  |
| 7-17   | Radio Set Control, C-11166/GRC-206 .....                          | 7-67  |
| 7-18   | Radio Set Control .....   | 7-69  |
| 7-19   | Circuit Card Assembly .....                                       | 7-72  |
| 7-20   | Circuit Card Assembly .....                                       | 7-78  |
| 7-21   | Radio Set Control Panel .....                                     | 7-85  |
| 7-22   | Case Assembly .....   | 7-87  |
| 7-23   | Circuit Card Assembly .....                                       | 7-92  |
| 7-24   | Electrical Mounting Base, MT-6250/GRC-206 .....                   | 7-94  |
| 7-25   | Distribution Box .....  | 7-109 |
| 7-26   | FM Bite/Audio Interface Assembly .....                            | 7-111 |
| 7-27   | Circuit Card Assembly .....                                       | 7-114 |
| FO-1   | Power Distribution Unit Schematic Diagram.....                    | FO-1  |



## LIST OF ILLUSTRATIONS - Continued

| Number | Title  | Page   |
|--------|--|--------|
| FO-2   | SDU Audio Interface (1) Schematic Diagram.....     | FO-3   |
| FO-3   | SDU Audio Interface (2) Schematic Diagram.....     | FO-21  |
| FO-4   | SDU Red Interface Schematic Diagram .....          | FO-43  |
| FO-5   | SDU Black Interface Schematic Diagram .....        | FO-55  |
| FO-6   | CPU Schematic Diagram.....                         | FO-67  |
| FO-7   | SDU Power Supply Schematic Diagram .....           | FO-79  |
| FO-8   | Fiber Optic Module Assembly Schematic Diagram..... | FO-83  |
| FO-9   | RSC Audio Interface Schematic Diagram.....         | FO-85  |
| FO-10  | RSC Digital Interface Schematic Diagram.....       | FO-109 |
| FO-11  | RSC Regulator Schematic Diagram .....              | FO-133 |
| FO-12  | FM BITE/Audio Interface Schematic Diagram.....     | FO-135 |
| FO-13  | Signal Distribution Unit Schematic Diagram .....   | FO-137 |
| FO-14  | RSC Front Panel Wiring Diagram.....                | FO-141 |
| FO-15  | RSC Schematic Diagram .....                        | FO-143 |
| FO-16  | Power Distribution Unit Wiring Diagram .....       | FO-145 |
| FO-17  | Signal Distribution Unit Wiring Diagram .....      | FO-147 |
| FO-18  | Panel Interface Schematic Diagram .....            | FO-153 |
| FO-19  | SDU Interface Schematic Diagram .....              | FO-163 |
| FO-20  | RT Interface Schematic Diagram .....               | FO-169 |

## LIST OF TABLES

| Number | Title  | Page  |
|--------|--|-------|
| 1-1    | Definitions of Terms and Abbreviations .....                       | 1-5   |
| 1-2    | Leading Particulars .....  | 1-13  |
| 1-3    | Capabilities and Limitations .....                                 | 1-16  |
| 1-4    | Special Tools List .....   | 1-17  |
| 1-5    | Test Equipment List .....  | 1-17  |
| 1-6    | Related Technical Manuals .....                                    | 1-20  |
| 3-1    | Items Requiring Special Attention .....                            | 3-2   |
| 4-1    | Machine Cycle Status .....   | 4-28  |
| 4-2    | Interrupt Priority, Restart Address and Sensitivity .....          | 4-30  |
| 5-1    | SDU Electrical Equipment Chassis Component Performance Tests ..... | 5-4   |
| 5-2    | SDU Electrical Equipment Chassis Fault Isolation Tests .....       | 5-4   |
| 5-3    | SDU Electrical Equipment Chassis Wiring List .....                 | 5-5   |
| 5-4    | SDU CCAs Performance Tests .....                                   | 5-14  |
| 5-5    | SDU CCAs Fault Isolation Tests.....                                | 5-29  |
| 5-6    | SDU Power Supply Component Performance Tests .....                 | 5-50  |
| 5-7    | SDU Power Supply Performance Test Voltages .....                   | 5-54  |
| 5-8    | SDU Power Supply Fault Isolation Tests .....                       | 5-55  |
| 5-9    | SDU Power Supply Fault Isolation Voltages .....                    | 5-61  |
| 5-10   | Fiber Optic Cable Assembly Performance Tests .....                 | 5-73  |
| 5-11   | Fiber Optic Cable Assembly Fault Isolation Tests .....             | 5-79  |
| 5-12   | Fiber Optic Cable Cleaning Kit (P/N 741889-801).....               | 5-83  |
| 5-13   | RSC CCAs Performance Tests .....                                   | 5-92  |
| 5-14   | RSC CCAs Fault Isolation Tests .....                               | 5-115 |
| 5-15   | RSC Test Set EPROM Select Codes .....                              | 5-142 |
| 5-16   | RSC Wiring List .....  | 5-146 |
| 5-17   | RSC Regulator CCA Component Performance Tests .....                | 5-158 |
| 5-18   | RSC Regulator CCA Fault Isolation Tests .....                      | 5-160 |
| 5-19   | FM BITE/Audio Interface Performance Tests .....                    | 5-168 |
| 5-20   | FM BITE/Audio Interface Fault Isolation Tests .....                | 5-172 |
| 5-21   | FM BITE/Audio Interface Wiring List .....                          | 5-177 |
| 5-22   | Distribution Box Component Performance Tests .....                 | 5-183 |
| 5-23   | Distribution Box Fault Isolation Tests .....                       | 5-183 |
| 5-24   | Distribution Box Wiring List .....                                 | 5-184 |
| 5-25   | PDU Electrical Equipment Chassis Component Performance Tests ..... | 5-187 |
| 5-26   | PDU Electrical Equipment Chassis Fault Isolation Tests .....       | 5-190 |
| 5-27   | PDU Electrical Equipment Chassis Wiring List .....                 | 5-193 |

## INTRODUCTION

This manual was prepared in accordance with military specifications MIL-M-38784A, MIL-M-38807A and MIL-M-38798B. This manual contains depot level maintenance information, with an illustrated parts breakdown, for Radio Communications System AN/GRC-206(V)1, part number 707167-801; and Radio Communications System AN/GRC-206(V)2, part number 707167-802. Both systems have secure voice capability. Radio Communications System AN/GRC-206(V)3 and AN/GRC-206(V)4 are essentially similar to Radio Communications System AN/GRC-206(V)1, except for the jam resistant electronic counter-countermeasures (ECCM) capability of the AN/GRC-206(V)3 and AN/GRC-206(V)4. For information on Radio Communications System AN/GRC-206(V)3, see TO 31R2-2GRC206-12-1. The chapter descriptions of this manual are as follows:

Chapter 1 contains general information for operation and maintenance familiarization.

Chapter 2 provides the preparation and installation instructions.

Chapter 3 provides information essential for use and shipment.

Chapter 4 explains the principles of operation.

Chapter 5 provides maintenance information.

Chapter 6 contains the circuit diagrams.

Chapter 7 contains the Illustrated Parts Breakdown.

Illustrations, charts, and tables supplement the text throughout for better understanding. General contents of this manual are reflected in the table of contents, list of illustrations, and list of tables. A cross-reference index and an alphabetical index are furnished to provide the location of a particular item.



## CHAPTER 1

## GENERAL INFORMATION

1-1. GENERAL. Radio Communication Systems AN/GRC-206(V)1 and AN/GRC-206(V)2 are illustrated in figure 1-1. The equipment purpose and capabilities are listed. The required special tools and test equipment are also listed and are illustrated. The definitions of terms and abbreviations are listed in table 1-1.

1-2. DESCRIPTION AND PURPOSE. The Radio System is a rack-mounted tactical communications system. Radio Communication Systems AN/GRC-206(V)1 and AN/GRC-206(V)2 are similar except that system AN/GRC-206(V)1 contains cabling and a shock mount to allow the mounting of Radio Frequency Oscillator O-1814/GRC-206 (RFO), used in Radio Communication System AN/GRC-206(V)3. These differences are features of Electrical Equipment Mounting Base MT-6250B/GRC-206. Depot level maintenance for it and the RFO is contained in TO 31R2-2GRC206-12-1. Systems AN/GRC-206(V)1 and AN/GRC-206(V)2 incorporate HF-SSB, VHF-FM, VHF-AM, and UHF-AM subsystems (fig. 1-2) and associated electronic equipment to provide radio communication capabilities in three communications bands. System AN/GRC-206(V)1 also provides all the mechanical and electrical interfaces (e.g., equipment mounts, cables, etc.) necessary to install and operate user-supplied communication security (COMSEC) equipment. The Radio System is intended for use by Tactical Air Control Parties for tactical ground-to-ground and ground-to-air communications and by other Tactical Air Control System (TACS) elements with similar requirements.

1-3. ELECTRICAL DESCRIPTION. The Radio System can be operated as a mobile or fixed tactical communication station. Primary power (+22.5 to +30.0 VDC) for the Radio System is supplied by either of two sources: vehicle electrical system during mobile operations or an auxiliary motor generator during stationary (fixed) operations. In addition, the Radio System is equipped with a power selector switch which allows the Radio System to be operated from the vehicle batteries for a short time should the main power sources become disabled. The Radio System provides the following communications capabilities: a HF-SSB subsystem, operating in the 2.0000 through 29.9999 MHz range; a VHF-FM subsystem, operating in the 30.00 through 75.95 MHz range; a VHF-AM subsystem, operating in the 116.000 through 149.975 MHz range; and a UHF-AM subsystem, operating in the 225.000 through 399.975 MHz range. Separate control and simultaneous operation of the above capabilities is possible, limited only by certain frequency combinations prone to interference and COMSEC restrictions. A signal distribution unit (SDU) is used to interface the four subsystems with one or two radio set controls (RSCs). The RSC/SDU interface allows complete control of the Radio System (through the use of local and remote cables) from local or remote locations. Local emergency operation is possible by bypassing (removing system interconnect cables from any subsystem) the RSC/SDU interface and controlling an individual subsystem by its front panel controls.

1-4. PHYSICAL DESCRIPTION. The following paragraphs describe the Radio System and its major components.

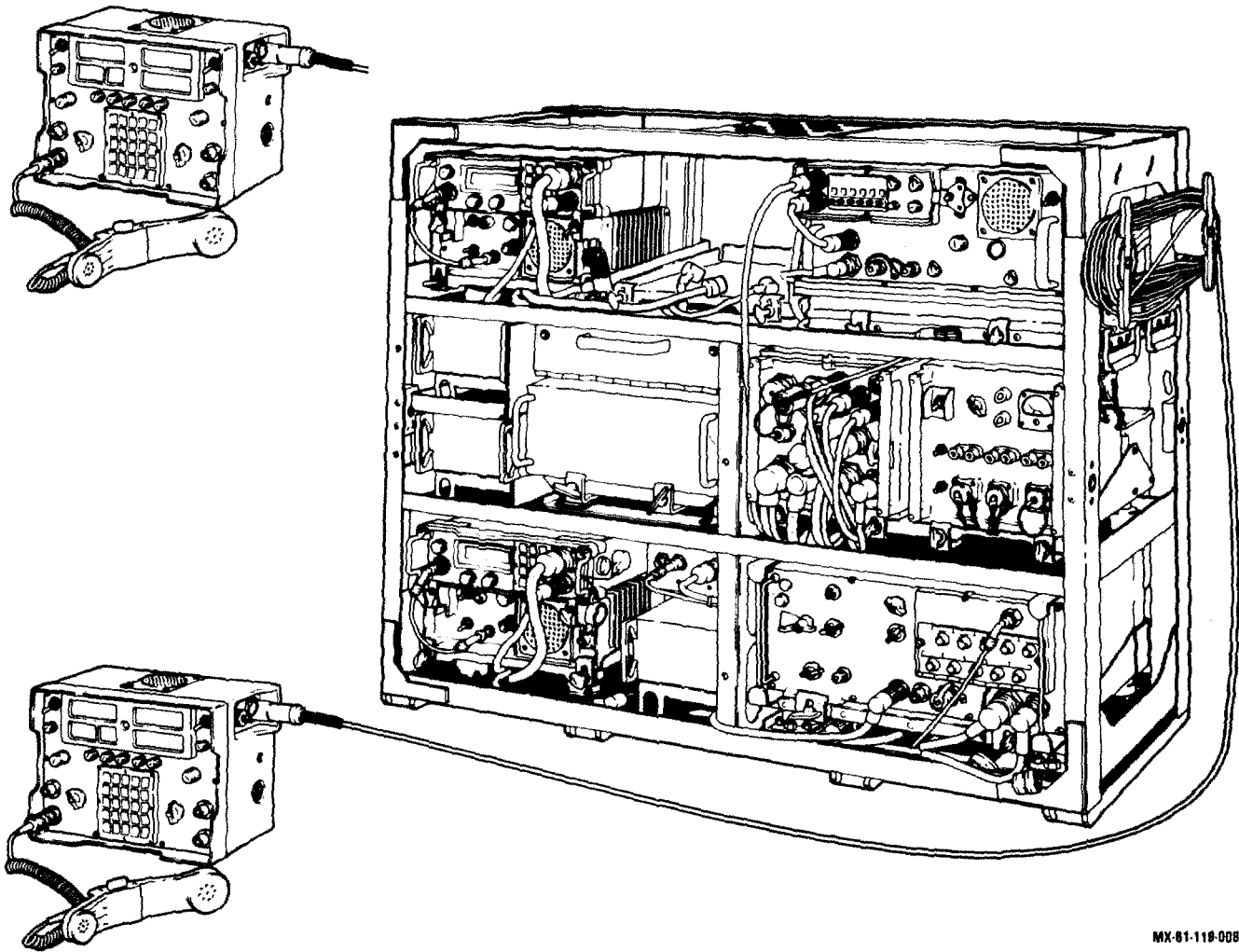

MX-81-118-008

Figure 1-1. Radio Communication System AN/GRC-206(V)1  
(Sheet 1 of 2)

MX-61-628-804  
276(V1), 012-1-33

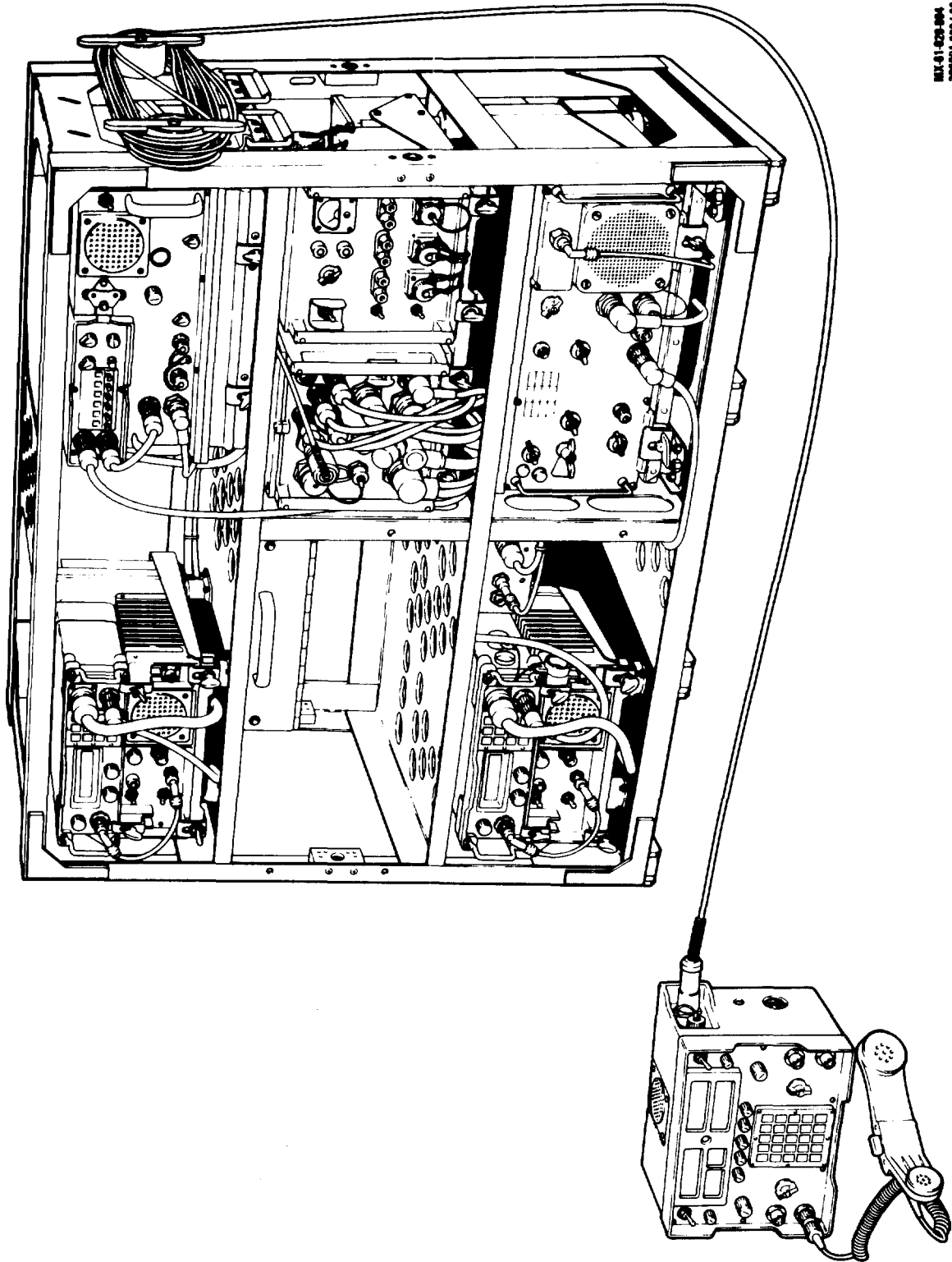

Figure 1-1. Radio Communications System AN/GRC-205 (V) 2  
(Sheet 2 of 2)

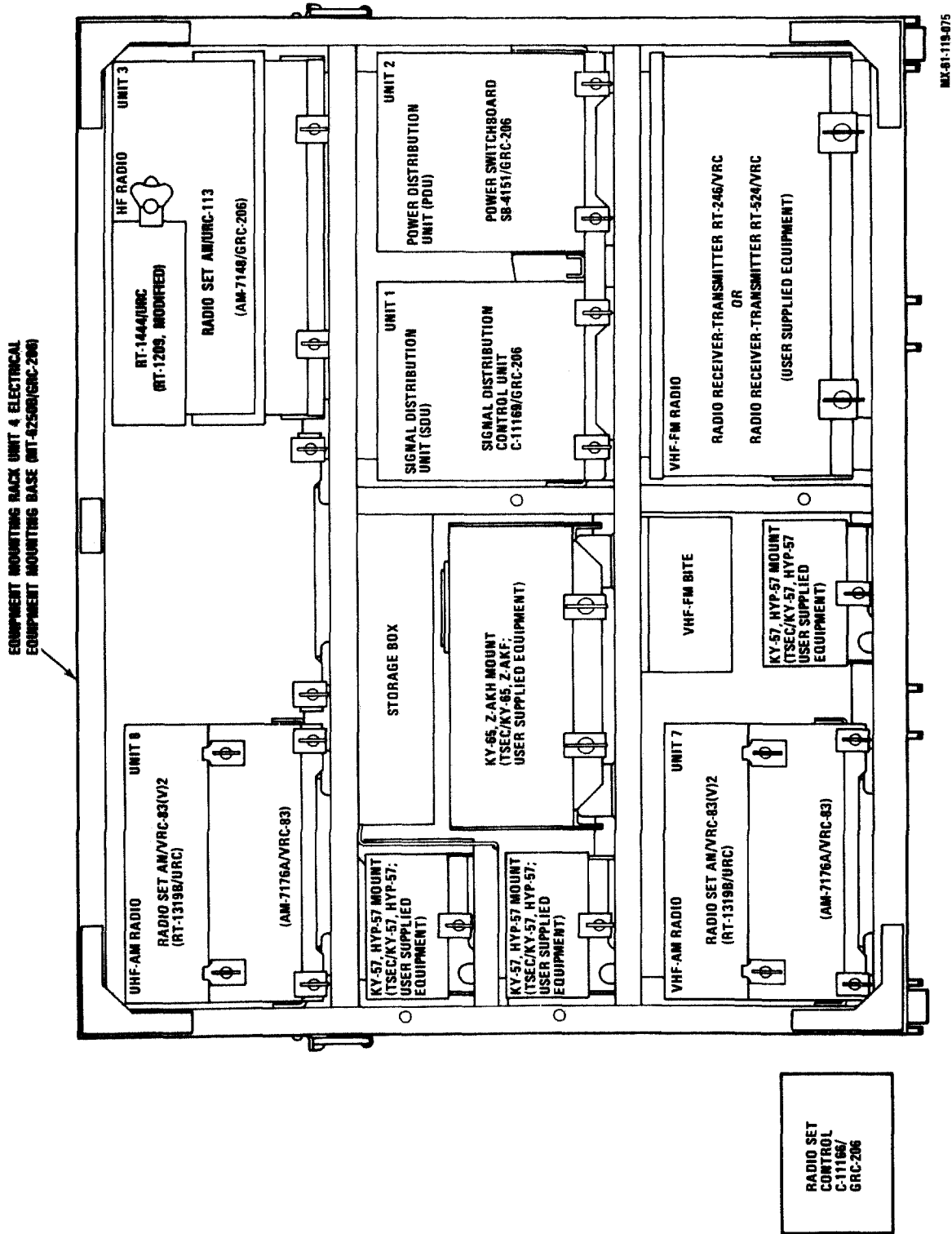

Figure 1-2. Radio System Component Location



Table 1-1. Definitions of Terms and Abbreviations

| Term/abbreviation   | Definition  |
|---------------------|---|
| A/D                 | analog-to digital   |
| AM                  | amplitude modulation  |
| Ancillary equipment | equipment not directly employed in the operation of the Radio System        |
| APC                 | Armored Personnel Carrier   |
| BITE                | built in test equipment   |
| CCA                 | circuit card assembly   |
| Cipher text         | secure voice communication  |
| COMSEC              | communication security  |
| COMSEC equipment    | communication security equipment (e.g., KY-65, Z-AKF, KY-57, KOI-18, etc.). |
| CPU                 | central processing unit   |
| CVSD (modem)        | continuously variable slope delta modulator/demodulator                     |
| D/A                 | digital-to-analog   |
| DAR                 | data available reset  |
| DCT                 | data communications terminal  |
| DVM                 | digital voltmeter   |
| EAROM               | electrically alterable ROM  |
| ELP                 | electroluminescent panel  |
| EOI                 | end of interrupt  |
| ESD                 | electrostatic discharge   |
| ESDS                | electrostatic discharge sensitive   |
| EMI                 | electromagnetic interference  |
| FF                  | flip-flop   |

Table 1-1. Definitions of Terms and Abbreviations - Continued

| Term/abbreviation | Definition  |
|-------------------|---|
| FM                | frequency modulation  |
| F/O cable         | fiber optic cable   |
| I/O               | input-output  |
| IC subsystem      | intercommunication subsystem  |
| kbps              | kilo-bits per second  |
| LCD               | liquid crystal display  |
| Local (emergency) | control is via the radio or radio set front panel controls              |
| Local (normal)    | control is via RSC-SDU interface  |
| LRU               | line replaceable unit   |
| LSB               | lower sideband  |
| M-113             | M-113-A1/A2 Armored Personnel Carrier                                   |
| M-151             | M-151 1/4 ton Utility Vehicle   |
| M-416             | M-416 1/4 ton Utility Trailer   |
| MHz               | megahertz   |
| MSI               | medium-scale integration  |
| NVIS antenna      | near-vertical-incident-skywave antenna                                  |
| OTDR              | optical time domain reflectometer                                       |
| PDU               | power distribution unit, (also referenced as power switchboard SB-4151) |
| PIC               | programmable interrupt controller                                       |
| PJU               | power junction unit   |
| Plain text        | clear voice communication   |
| PLRT              | polarity  |

Table 1-1. Definitions of Terms and Abbreviations - Continued

| Term/abbreviation | Definition  |
|-------------------|---|
| PTT               | push-to-talk  |
| RETX              | re-transmit   |
| RFO               | reference frequency oscillator  |
| RF subsystem      | radio set and associated components   |
| ROM               | read only memory  |
| RSC               | radio set control   |
| RSC-SDU interface | link between operator and RF subsystems   |
| RT                | receiver-transmitter (Unless otherwise prefixed, used to refer to RT-1319B/URC) |
| SDI               | serial data input   |
| SDO               | serial data output  |
| SDU               | signal distribution unit  |
| SRU               | shop replaceable unit   |
| SSB               | single sideband   |
| THRL              | transmitter holding register load   |
| TIP               | tune in progress  |
| TOD               | time of day   |
| UART              | universal asynchronous receiver/transmitter                                     |
| URSC              | unified radio set control   |
| USART             | universal synchronous asynchronous receiver/transmitter                         |
| USB               | upper sideband  |
| UTC               | coordinated universal time  |
| UUT               | unit under test   |

Table 1-1. Definitions of Terms and Abbreviations - Continued

| Term/abbreviation | Definition                        |
|-------------------|-----------------------------------|
| Vehicle           | M-113 or M-151 with M-416 Trailer |
| VSWR              | voltage standing wave ratio       |
| WOD               | word of day                       |

1-5. RADIO SYSTEM. The Radio System is configured within a welded aluminum mounting rack. The RF subsystems are independently mounted and interwired within the mounting rack. Line replaceable units (LRUs) within the mounting rack are mounted on mounting adapters which allow the LRUs to be removed from the mounting rack without the removal of another LRU.

1-6. EQUIPMENT MOUNTING RACK. The equipment mounting rack is a welded aluminum mounting structure of modular design. It provides mounting and consolidation of individual radio sets and electronic equipment into a Radio System for vehicle mounting. It also provides for stowage of ancillary items (e.g., handsets, small cables, and manuals). The equipment mounting rack supplied with system AN/GRC-206(V)1 also contains mounting adapters and cables for COMSEC equipment used during secure voice operations.

1-7. POWER SWITCHBOARD. Primary power for the Radio System is applied through the power switchboard. The power switchboard (PDU) receives primary input power from two possible sources: the vehicle electrical system or an auxiliary motor generator. A power circuit breaker on the power switchboard front panel is used to interrupt input power to rack-mounted equipment. A selector switch is used to select between the two primary sources or vehicle override (vehicle battery). A meter is provided to monitor primary input power. A power indicator lights when input power to the rack-mounted equipment is turned on. A vehicle override warning lamp is used to alert the operator when equipment operation is being supported by the vehicle battery. Three positive (+) and three negative (-) binding posts are provided to give interconnect points for miscellaneous 28 volt operated accessories. Two auxiliary connectors (J1 and J2) also provide an output of the input power. Input power available at the auxiliary outputs (binding post and connectors J1, J2) is controlled by two independent circuit breakers. Another auxiliary connector (J3) provides reserve no-break-power from the vehicle battery (J3 is not used with Radio System configurations covered in this manual).

1-8. SIGNAL DISTRIBUTION UNIT. The SDU is the center of control for the Radio System. It is a microprocessor-based interface unit which processes all control, monitor, and command functions for the Radio System. The SDU provides the means to maintain communications once established by the operator. It resolves operator-to-operator and man-machine conflicts in accordance with pre-programmed instructions stored in its memory circuits. It is also the COMSEC controller for system AN/GRC-206(V)1, blocking all improper COMSEC operating scenarios associated with cipher text (secure voice) communications. All input-output (I/O) interfaces to the SDU are made via 14 connectors mounted on the SDU front panel.

1-9. RADIO SET CONTROL. The RSC provides the capability to control and monitor the operation of the Radio System. It is the I/O terminal for the SDU and is functionally linked to the SDU via a fiber optic (F/O) cable. Two RSCs are supplied with each Radio System. Each RSC can be operated by one to two operators. Remote F/O cabling is provided with the Radio System to deploy one RSC up to a distance of 2 km (6,562 ft). The RSC can be remotely deployed to a distance of 3 km (9,843 ft) by connecting an additional 1 km (3,281 ft) of F/O cable (user-supplied). The RSC front panel provides all the displays, controls, switches, and connectors necessary to allow operator interface and control of each RF subsystem. Power to the RSC is

supplied by either of two sources: internal batteries during remote operation or the SDU during local operation at distances up to 6 meters (20 ft).

1-10. HF SUBSYSTEM. The HF-SSB subsystem consists of Radio Set AN/URC-113, a HF whip antenna, a HF near-vertical-incident-skywave (NVIS) antenna, and required cables. The HF equipment provides voice operation on the upper or lower sideband. The HF radio set may be operated on any one of 280,000 channels and may be used for ground-to-ground or ground-to-air communications. It also provides automatic tuning and antenna impedance matching. It may be operated from its front panel during local (emergency) operations or from the RSC-SDU interface during local (normal) or remote operations.

1-11. VHF-FM SUBSYSTEM. The VHF-FM subsystem consists of Receiver-Transmitter RT-524/VRC (RT-524) or RT-246/VRC (RT-246), a VHF BITE panel, a VHF-FM antenna (whip) and required cables. The VHF-FM equipment provides FM voice communication in the VHF range. The RT-524 and RT-246 are user-supplied and operate on any one of 920 frequency channels in the 30.00 through 75.95 MHz band. The RT-246 is a remote controllable RT and is capable of accepting up to ten preset channels. Once the preset channels have been manually loaded into RT-246, preset channel selection is possible via the RSC-SDU interface. The RT-524 is the manual version of the RT-246. It does not have preset capabilities, and all frequencies must be manually entered via its front-panel controls. The RSC-SDU interface with the RT-524 allows control of the transmit key and audio interface. Squelch selection for either RT remains at the RT's front panel. Both RTs can be operated (locally) during emergency operation from their front-panel controls. The VHF BITE panel 8 is hard-mounted to the equipment mounting rack. The VHF BITE panel monitors the RF output power for drops more than -3 dB below the minimum specified RF power. The VHF BITE panel also provides audio and COMSEC interface signal conditioning.

1-12. VHF-AM SUBSYSTEM. The VHF-AM subsystem consists of Radio Set AN/VRC-83(V)1, a VHF/UHF antenna, and required cables. The VHF-AM equipment provides AM voice, ground-to-air communications in the VHF range. The VHF-AM radio set may be operated on any one of 1360 frequency channels in the 116.000 through 149.975 MHz frequency range. The VHF-AM radio set is capable of accepting up to eight preset channels and is remote controllable via the RSC-SDU interface. The VHF-AM radio set can also be operated (locally) during emergency operation from its front-panel controls.

1-13. UHF-AM SUBSYSTEM. The UHF-AM subsystem consists of Radio Set AN/VRC-83(V)1, a VHF/UHF antenna, and required cables. The UHF-AM equipment provides AM voice, ground-to-air communication in the UHF range. The UHF-AM radio set may be operated on any one of 7000 frequency channels in the 225.000 through 399.975 MHz frequency range. The UHF-AM radio set is capable of accepting up to eight preset channels and is remote controllable via the RSC-SDU interface. The UHF-AM radio set can also be operated (locally) during emergency operation from its front-panel controls.

1-14. ANTENNA SYSTEMS. The Radio System uses three separate vehicle-mounted antennas to receive and transmit in three communication bands. In addition to the three vehicle-mounted antennas which can be used for fixed or mobile operation, an NVIS antenna kit is stowed in the vehicle for use as an HF fixed station antenna. The four antennas supplied with each Radio System are shown in figure 1-3 and are described in the following paragraphs.

a. HF (WHIP) Antenna. The HF whip antenna kit (AT-1011) consists of an eight-section, 32-foot HF whip antenna and a canvas transit bag. The antenna sections may be assembled to make either a 16-foot or 32-foot whip antenna. The 16-foot length is used for mobile or stationary operations, and the 32-foot length is used for stationary operations. The HF whip antenna is capable of operation over the frequency range of 2.0000 through 29.9999 MHz. Automatic tuning of the HF whip antenna is provided by the HF radio set amplifier-coupler.

b. HF (NVIS) Antenna. The HF NVIS propagation antenna kit (AS-2259/GR) consists of an eight-section, 15-foot NVIS antenna, an antenna-to-antenna base adapter (MX-9313/GR), and a canvas transit bag. The NVIS propagation antenna is capable of operation over the frequency range of 2.0000 through 14.0000 MHz. The NVIS antenna is used with the HF radio to increase the range above the distance that is normally possible with the HF whip antenna during stationary operation. Automatic tuning of the NVIS antenna is provided by the HF radio set amplifier-coupler.

c. VHF-FM Antenna. The VHF-FM antenna (AS-1729/VRC) consists of a center-fed whip antenna. The antenna is used for mobile or stationary operation over the frequency range of 30.00 through 75.95 MHz. The base compensation network provides control of the input VSWR.

d. VHF/UHF Antenna. The VHF/UHF antenna (AS-3588/GRC-206) is a combined VHF/UHF antenna with separate UHF and VHF ports on the antenna base. The antenna is capable of operation over the frequency range of 116.000 through 149.975 MHz (VHF) and 225.000 through 399.975 MHz (UHF). The VHF/UHF antenna is vertically polarized and produces an omnidirectional peak radiation pattern.

#### 1-15. ACCESSORY AND ANCILLARY EQUIPMENT.

a. Fiber Optic Cables and Reel Assemblies. Two 1 km F/O cables with reel assemblies are provided with each Radio System. The two F/O cables and reel assemblies allow remote deployment of one or two RSCs.

b. Electrical Equipment Rack. The electrical equipment rack provides stowage provisions for COMSEC equipment used with system AN/GRC-206(V)1. The electrical equipment rack has provisions for storing two TSEC/KY-57s, one TSEC/KY-65, and the associated vehicle power adapters required for COMSEC equipment operation. A security hasp is incorporated on the rack to accommodate a user-supplied padlock to prevent pilferage.

1-16. COMSEC EQUIPMENT COMPATIBILITY. System AN/GRC-206(V)1 has provisions to operate in clear or secure voice modes. Mechanical and electrical interfaces are provided with system AN/GRC-206(V)1 to mount and operate user-supplied COMSEC equipment. When the Radio System is configured for secure voice operation, audio I/O signals are via compatible voice ciphering equipment (KY-65 or KY-57 COMSEC equipment). Visual indicators are provided on the RSC front panel to indicate text status (plain or cipher) of each RF subsystem.

1-17. LEADING PARTICULARS. The leading particulars for the systems AN/GRC-206(V)1 and AN/GRC-206(V)2 are listed in table 1-2.

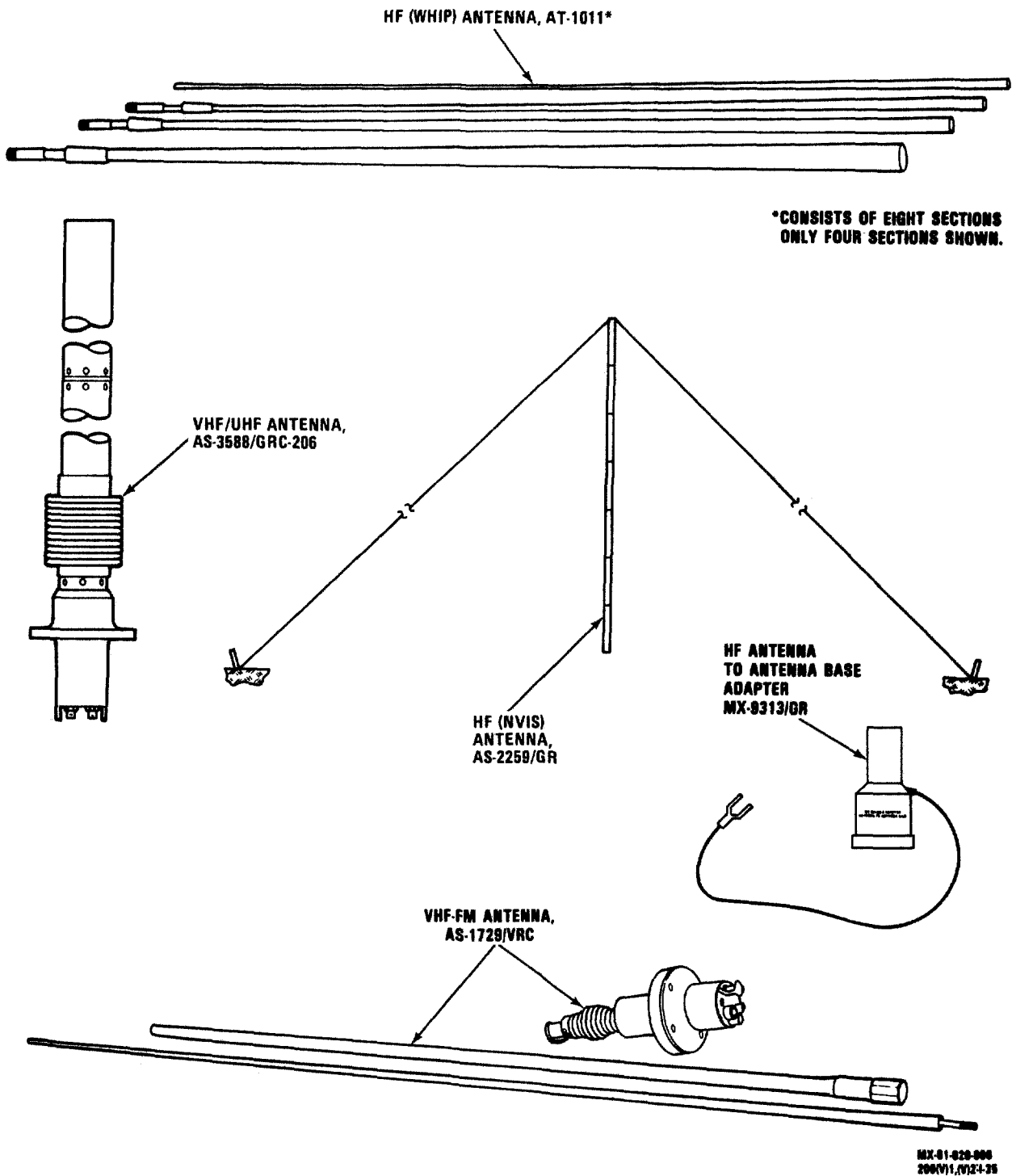

Figure 1-3. Radio System Antennas



Table 1-2. Leading Particulars

| Characteristic                            | Description                                   |
|---|---|
| PRIMARY POWER REQUIREMENTS                |   |
| Input power                               | +22.5 to +30.0 VDC at 1500 watts<br>(maximum) |
| Power available                           |   |
| M-151 vehicle alternator                  | +28.0 VDC at 1500 watts                       |
| M-113 vehicle alternator                  | +28.0 VDC at 1500 watts                       |
| Auxiliary motor generator                 | +27.5 VDC at 1500 watts                       |
| (MEP-025) MIL-G-52732/5                   |   |
| (MEP-026) MIL-G-52732/8                   |   |
| Power required                            |   |
| All equipment on (two transmitters keyed) | 1500 watts, maximum                           |
| All equipment on                          | 150 watts, average                            |
| HF Radio Set                              |   |
| Transmit                                  | 525 watts, maximum                            |
| Receive                                   | 30 watts, maximum                             |
| VHF-FM Radio                              |   |
| Transmit                                  | 300 watts, maximum                            |
| Receive                                   | 50 watts, nominal                             |
| VHF-AM Radio Set                          |   |
| Transmit                                  | 275 watts, maximum                            |
| Receive                                   | 30 watts, nominal                             |
| UHF-AM Radio Set                          |   |
| Transmit                                  | 275 watts, maximum                            |
| Receive                                   | 30 watts, nominal                             |

Table 1-2. Leading Particulars - Continued

| Characteristic  | Description                           |
|---|---------------------------------------|
| <b>EQUIPMENT DIMENSIONS AND WEIGHT</b>                |                                       |
| Electrical Equipment Mounting<br>Base MT-6250/GRC-206 |                                       |
| Width   | 38 in. (96.52 cm)                     |
| Height  | 31 in. (78.74 cm)                     |
| Depth   | 16 in. (40.64 cm)                     |
| Weight*, (MT-6250/GRC-206)                            | 368 lb (167 kg)                       |
| (MT-6250A/GRC-206)                                    | 308 lb (140 kg)                       |
| * Includes all radio equipment.                       |                                       |
| Control, Signal Distribution Unit<br>C-11169/GRC-206  |                                       |
| Width   | 7.50 in. (19.05 cm)                   |
| Height  | 7.50 in. (19.05 cm)                   |
| Depth   | 9.08 in. (22.98 cm)                   |
| Weight  | 12.5 lb (5.68 kg)                     |
| Switchboard, Power SB-4151/<br>GRC-206                |                                       |
| Width   | 7.50 in. (19.05 cm)                   |
| Height  | 7.50 in. (19.05 cm)                   |
| Depth   | 9.82 in. (24.9 cm)                    |
| Weight  | 10.5 lb (4.77 kg)                     |
| Control, Radio Set C-11166/<br>GRC-206, (2 ea)        |                                       |
| Width   | 12.06 in. (30.63 cm)                  |
| Height  | 8.06 in. (20.47 cm)                   |
| Depth   | 5.33 in. (13.54 cm)                   |
| Weight  | 15.06 lb (6.8 kg) - without batteries |
|   | 19.51 lb (8.85 kg) - with BA-5590     |
|   | batteries                             |
|   | 23.02 lb (10.4 kg) - with BB-590      |
|   | batteries                             |

Table 1-2. Leading Particulars - Continued

| Characteristic   | Description          |
|--|----------------------|
| Radio Set, AN/URC-113                                    |                      |
| Width  | 14.00 in. (35.56 cm) |
| Height   | 7.58 in. (19.25 cm)  |
| Depth  | 15.25 in. (38.74 cm) |
| Weight   | 37.4 lb (16.96 kg)   |
| Radio Set, AN/VRC-83(V)1, (2 ea)                         |                      |
| Width  | 10.37 in. (26.34 cm) |
| Height   | 6.50 in. (16.51 cm)  |
| Depth  | 12.50 in. (31.75 cm) |
| Weight   | 33.9 lb (15.38 kg)   |
| Receiver-Transmitter, Radio<br>RT-246/VRC and RT-524/VRC |                      |
| Width  | 15.93 in. (40.46 cm) |
| Height   | 6.75 in. (17.15 cm)  |
| Depth  | 14.00 in. (35.56 cm) |
| Weight, RT-246   | 61 lb (27.57 kg)     |
| RT-524   | 58 lb (26.31 kg)     |
| Rack, Electrical Equipment<br>MT-6251/GRC-206            |                      |
| Width  | 21.0 in. (53.34 cm)  |
| Height   | 20.0 in. (50.8 cm)   |
| Depth  | 8.25 in. (20.96 cm)  |
| Weight   | 10.0 lb (4.54 kg)    |

1-18. CAPABILITIES AND LIMITATIONS. The capabilities and limitations of the systems AN/GRC-206(V)1 and AN/GRC-206(V)2 are listed in table 1-3. Only those subsystems which are to be maintained at depot level are listed. For information on other subsystems, see TO 31R2-2GRC206-2.

Table 1-3. Capabilities and Limitations

| Capability/limitation   | Description   |
|---|---|
| HF-SSB subsystem<br>Frequency range<br>Available channels<br>Preset channels<br>Output power<br>Antenna impedance<br>Antenna tuning time<br>Type of modulation<br>Mode of operation | 2.0000 MHz to 29.9999 MHz at 100 Hz intervals<br>280,000 channels<br>None<br>150 watts average power<br>50 ohms at 15 MHz<br>1.0 seconds typical; 5.0 seconds maximum<br>SSB (upper and lower sidebands)<br>Voice, secure voice, digital data |

1-19. EQUIPMENT SUPPLIED. Refer to TO 31R2-2GRC206-2 for list of equipment supplied with systems AN/GRC206(V)1 and AN/GRC206(V)2.

1-20. EQUIPMENT REQUIRED BUT NOT SUPPLIED. Refer to TO 31R2-2GRC206-2 for list of additional equipment required for the maintenance of systems AN/GRC206(V)1 and AN/GRC206(V)2.

1-21. SPECIAL TOOLS AND TEST EQUIPMENT. The special tools required for the maintenance of systems AN/GRC206(V)1 and AN/GRC206(V)2 are listed in table 1-4. Test equipment required is listed in table 1-5. The SDU Test Set TS-4132 controls, indicators and connectors are shown in figure 1-4.

Table 1-4. Special Tools List

| Part (tool) number | Mfr. code or name        | Figure and index no. | Nomenclature             | Use   |
|--------------------|--------------------------|----------------------|--------------------------|---|
|                    | Fiber Optic Cleaning Kit | --                   | Fiber Optic Cleaning Kit | Used to clean fiber fiber optic cables during test. |

Table 1-5. Test Equipment List

| Type designation/<br>part no.      | Alternate type designation | Figure and index no. | Nomenclature                  | Use  |
|------------------------------------|----------------------------|----------------------|-------------------------------|--|
| HP182C                             | Equivalent                 | --                   | Oscilloscope, Main Frame      | Provides display of signals during test.               |
| HP200CD                            | Equivalent                 | --                   | Signal generator              | Generator audio test signal.                           |
| HP339A                             | Equivalent                 | --                   | Distortion Meter              | Measures the distortion in dBs of the UUT.             |
| HP6443B                            | Equivalent                 | --                   | Regulated Power Supply, DC    | Used to provide -17.5 VDC.                             |
| HP8656A                            | Equivalent                 | --                   | RF Signal Generator           | Generates RF signals for use during test.              |
| QRD30-1<br>Sorenson                | Equivalent                 | --                   | Power Supply DC (2 required)  | Provides DC voltage for test set and UUT.              |
| HP6268B,<br>OPT 26<br>(3 required) | Equivalent                 | --                   | Regulated Power Supply, DC    | Provides prime voltage input source.                   |
| QRD40-2<br>Sorenson                | Equivalent                 | --                   | Power Supply, DC (2 required) | Provides DC voltage for test set and UUT.              |
| TS4132/<br>GRC-206(V)              | None                       | 1-5                  | SDU Test Set                  | Provides interconnection and test signals during test. |

Table 1-5. Test Equipment List - Continued

| Type designation/<br>part no. | Alternate type designation | Figure and index no. | Nomenclature             | Use  |
|-------------------------------|----------------------------|----------------------|--------------------------|--|
| TS4133/                       | None                       | 5-13                 | RSC Test Set             | Provides interconnection and test signals during test.       |
| X10 Oscilloscope Probe        | Equivalent                 | --                   | X10 probe                | Provides a one-tenth oscilloscope presentation reading.      |
| 2051 Yokogawa                 | Equivalent                 | --                   | DC Amp Meter             | Used to measure 0-30 amps.                                   |
| 8300A<br>John Fluke           | Equivalent                 | --                   | Multimeter,<br>digital   | Used to measure resistance and voltage values.               |
| TS4090                        | None                       | 1-0                  | Power Converter Test Set | Used to test RSC regulator CCA and SDU power supply CCA.     |
| OF150                         | Equivalent                 |                      | Fiber Optic OTDR         | Measures dB loss and location of loss in fiber optic cables. |

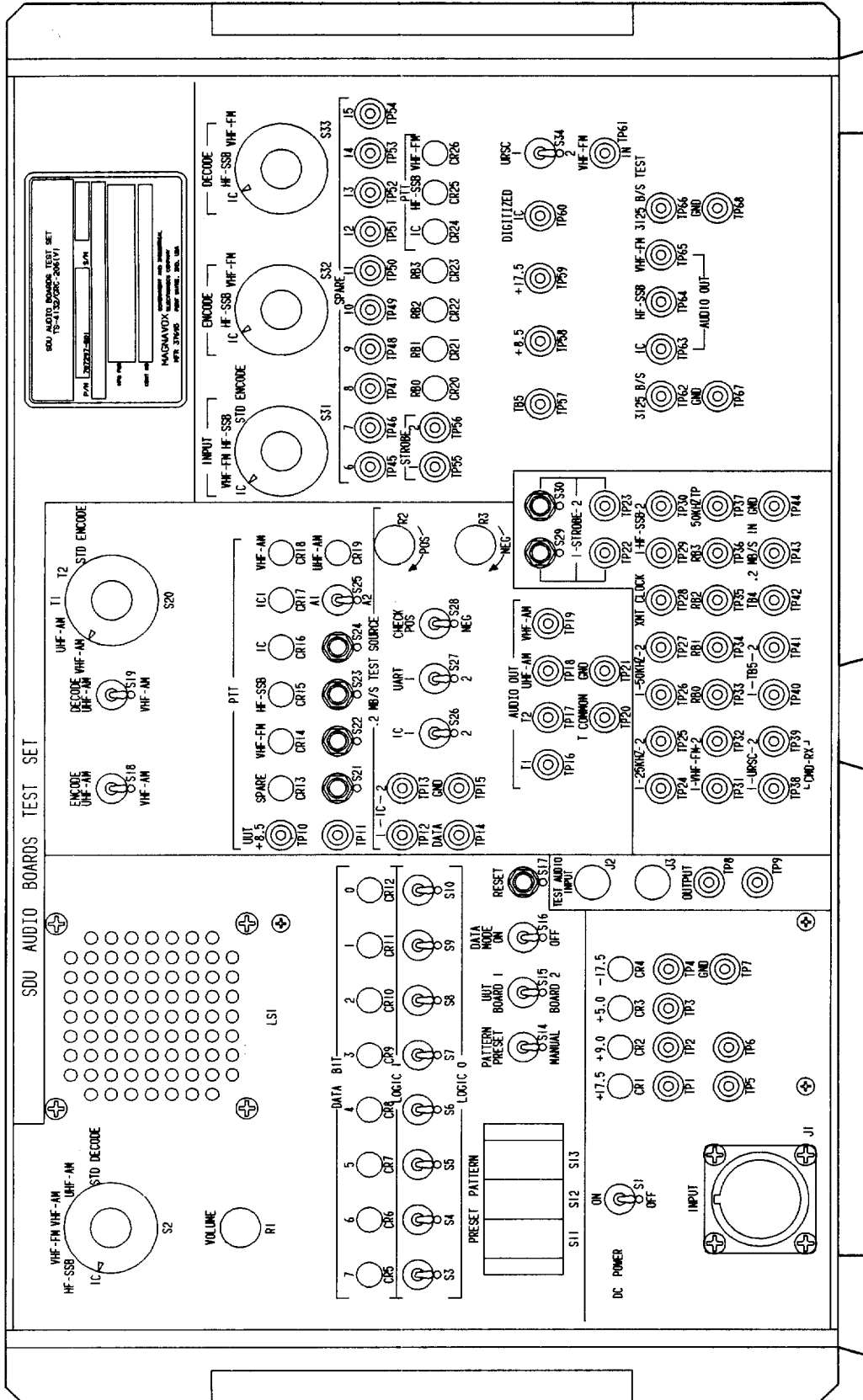

ML 61-118-010

Figure 1-4. TS-4132 SDU Test Set Controls, Indicators and Connectors.

1-22. RELATED TECHNICAL MANUALS. The related technical manuals required for maintenance of AN/GRC206(V)1 and AN/GRC206(V)2 are listed in table 1-6.

Table 1-6. Related Technical Manuals

| Publication no.         | Publication title  | Equipment nomenclature            |
|-------------------------|--|-----------------------------------|
| TO 31R2-2PRC113-1       | Operator's Manual for Radio Set AN/PRC-113(V)1, PN 706738-801  | Radio Set AN/PRC-113(V)1          |
| TO 31R2-2PRC113-1-1     | Supplemental Operator's Manual for Radio Set AN/PRC-113(V)3, PN 706738-803   | Radio Set AN/PRC-113(V)3          |
| TO 31R2-2PRC113-6WC-1   | Scheduled Periodic Inspection Workcards, Radio Set AN/PRC-113(V)1, PN 706738-801                                     | Radio Set AN/PRC-113(V)1          |
| TO 31R2-2PRC113-6WC-1-1 | Supplemental Scheduled Periodic Inspection Workcards, Radio Set AN/PRC-113(V)3, PN 706738-803                        | Radio Set AN/PRC-113(V)3          |
| TO 31R2-2URC62          | Maintenance Instructions with IPB, Intermediate Level, Receiver-Transmitter RT-1319/URC, PN 914858-801               | Receiver-Transmitter RT-1319/URC  |
| TO 31R2-2URC62-1        | Supplemental Maintenance Instructions with IPB, Intermediate Level, Receiver-Transmitter RT-1319B/URC, PN 914858-803 | Receiver-Transmitter RT-1319B/URC |
| TO 31R2-2URC63          | Maintenance Instructions with IPB, Depot Level, Receiver-Transmitter Rt-1319/URC, PN 914858-801                      | Receiver-Transmitter RT-1319/URC  |
| TO 31R2-2URC-63-1       | Supplemental Maintenance Instructions with IPB, Depot Level, Receiver-Transmitter RT-1319B/URC, PN 914585-803        | Receiver-Transmitter RT-1319B/URC |



Table 1-6. Related Technical Manuals - Continued

| Publication no.         | Publication title   | Equipment nomenclature   |
|-------------------------|---|--------------------------|
| TO 31R2-2TRC176-1       | Operator's Manual for Radio Set AN/TRC-176(V)1, PN 706710-801   | Radio Set AN/TRC-176(V)1 |
| TO 31R2-2TRC176-1-1     | Supplemental Operator's Manual for Radio Set AN/TRC-176(V)2, PN 706710-802                                  | Radio Set AN/TRC-176(V)2 |
| TO 31R2-2TRC176-2       | Maintenance Instructions with IPB, Intermediate Level, Radio Set AN/TRC-176(V)1, PN 706710-801              | Radio Set AN/TRC-176(V)1 |
| TO 31R2-2TRC176-2-1     | Supplemental Maintenance Instructions with IPB, Intermediate Level, Radio Set AN/TRC-176(V)2, PN 706710-802 | Radio Set AN/TRC-176(V)2 |
| TO 31R2-2TRC176-3       | Maintenance Instructions with IPB, Depot Level, Radio Set AN/TRC-176(V)1, PN 706710-801                     | Radio Set AN/TRC-176(V)1 |
| TO 31R2-2TRC-176-3-1    | Supplemental Maintenance Instructions with IPB, Depot Level, Radio Set TRC-176(V)2, PN 706710-803           | Radio Set AN/TRC-176(V)2 |
| TO 31R2-2TRC176-6WC-1   | Scheduled Periodic Inspection Workcards, Radio Set AN/TRC-176(V)1, PN 706710-801                            | Radio Set AN/TRC-176(V)1 |
| TO 31R2-2TRC176-6WC-1-1 | Supplemental Scheduled Periodic Inspection Workcards, Radio Set AN/TRC-176(V)2, PN 706710-802               | Radio Set AN/TRC-176(V)2 |
| TO 31R2-2VRC83-1        | Operator's Manual for Radio Set AN/VRC-83(V)1, PN 707123-801  | Radio Set AN/VRC-83(V)1  |

Table 1-6. Related Technical Manuals - Continued

| Publication no.        | Publication title  | Equipment nomenclature                        |
|------------------------|--|---|
| TO 31R2-2VRC83-1-1     | Supplemental Operator's Manual for Radio Set AN/VRC-83(V)2, PN 707123-803  | Radio Set AN/VRC-83(V)2                       |
| TO 31R2-2VRC83-2       | Maintenance Instructions with IPB, Intermediate Level, Radio Set AN/VRC-83(V)1, PN 707123-801                    | Radio Set AN/VRC-83(V)1                       |
| TO 31R2-2VRC83-2-1     | Supplemental Maintenance Instructions with IPB, Intermediate Level, Radio Set AN/VRC-83(V)2, PN 707123-803       | Radio Set AN/VRC-83(V)2                       |
| TO 31R2-2VRC83-3       | Maintenance Instructions with IPB, Depot Level, Radio Set VRC-83(V)1, PN 707123-801                              | Radio Set AN/VRC-83(V)1                       |
| TO 31R2-2VRC-83-3-3    | Supplemental Maintenance Instructions with IPB, Depot Level, Radio Set AN/VRC-83(V), PN 707123-803               | Radio Set AN/VRC-83(V)1                       |
| TO 31R2-2VRC83-6WC-1   | Scheduled Periodic Inspection Workcards, Radio Set AN/VRC-83(V)1, PN 707123-801                                  | Radio Set AN/VRC-83(V)1                       |
| TO 31R2-2VRC83-6WC-1-1 | Supplemental Scheduled Periodic Inspection Workcards, Radio Set AN/VRC-83(V)2, PN 707123-802                     | Radio Set AN/VRC-83(V)2                       |
| TO 31R2-2GRC206-1      | Operator's Manual for Radio Communication System AN/GRC-206(V)1, PN 707167-801 and AN/GRC-206(V)2, PN 707167-802 | Radio Communication System AN/GRC-206(V)1 & 2 |

Table 1-6. Related Technical Manuals - Continued

| Publication no.      | Publication title   | Equipment nomenclature                         |
|----------------------|---|--|
| TO 31R2-2GRC206-1-1  | Supplemental Operator's Manual for Radio Communication System AN/GRC-206(V)3, PN 707167-803   | Radio Communication System AN/GRC-206(V)3      |
| TO 31R2-2GRC206-2    | Maintenance Instructions with IPB, Intermediate Level, Radio Communication System AN/GRC-206(V)1, PN 707167-801 and AN/GRC-206(V)2, PN 707167-802 | Radio Communications System AN/GRC-206(V)1 & 2 |
| TO 31R2-2GRC206-2-1  | Supplemental Maintenance Instructions with IPB, Intermediate Level, Radio Communications System AN/GRC-206(V)3, PN 707167-803                     | Radio Communications System AN/GRC-206(V)3     |
| TO 31R2-2GRC206-12   | Maintenance Instructions with IPB, Depot Level, Radio Communication System AN/GRC206(V)1, PN 707167-803   | Radio Communications System AN/GRC-206(V)1     |
| TO 31R2-2GRC206-12-1 | Supplemental Maintenance Instructions with IPB, Depot Level, Radio Communication System AN/GRC206(V)1, PN 707167-803                              | Radio Communications System AN/GRC-206(V)1     |
| TO 31R2-2GRC206-22   | Maintenance Instructions with IPB, (Depot) Amplifier-Coupler, AM-7148/GRC-206, PN 622-6147-001, NSN 5895-01-1491                                  | Amplifier-Coupler AM-7148/GRC-206              |
| TO 31R2-2VRC-192     | Field and Depot Maintenance Manual, Receiver-Transmitters RT-246/VRC and RT-524/VRC   | Receiver-Transmitter RT-246/VRC & RT-524/VRC   |

Table 1-6. Related Technical Manuals - Continued

| Publication no.     | Publication title   | Equipment nomenclature   |
|---------------------|---|--|
| TO 31R2-2VRC-221    | Operator's and Organizational Maintenance Manual Including Repair Parts and Special Tools Lists, Radio Sets AN/VRC-12, AN/VRC-43, AN/VRC-44, AN/VRC-45, AN/VRC-46, AN/VRC-47, AN/VRC-48, AN/VRC-49, AN/VRC-54, and AN/VRC-55; Mounting MT-1029/VRC and Mounting MT-1898/VRC, Antenna AT/912/VRC; Control, Frequency Selector C-2742/VRC and Control, Radio Set C-2299/VRC | Radio Sets AN/VRC-12, AN/VRC-43, AN/VRC-44, AN/VRC-45, AN/VRC-46, AN/VRC-47, AN/VRC-48, AN/VRC-49, AN/VRC-54, and AN/VRC-55; Mounting MT-1029/VRC and Mounting MT-1898/VRC, Antenna AT/912/VRC; Control, Frequency Selector C-2742/VRC and Control, Radio Set C-2299/VRC |
| TO 31R2-2PRC104-2   | Field Maintenance Instructions, Radio Set AN/PRC-104  | Radio Set AN/PRC-104   |
| TO 31R2-2PRC104-2-1 | Supplemental Field Maintenance Instructions, Receiver-Transmitter RT-1444/URC (Part of Radio Set AN/PRC-104)  | Receiver-Transmitter RT-1444/URC   |
| TO 31R2-2PRC104-4   | Repair Parts List for Radio Set AN/PRC-104  | Radio Set AN/PRC-104   |
| TO 31R2-2PRC104-4-1 | Supplemental Illustrated Parts Breakdown, Receiver-Transmitter RT-1444/URC* (Part of Radio Set AN/PRC-104)  | Receiver-Transmitter RT-1444/URC   |
| TO 33DA27-17-1      | Operation and Maintenance Instructions with Illustrated Parts Breakdown, Power Converter Test Set TS-4090/GRC-206(V), PN 812540-801   | Power Converter Test Set TS-4090/GRC-206(V)  |
| TO 33DA48-25-1      | Operation and Maintenance Instructions with Illustrated Parts Breakdown, Modulator Test Set TS-4092/URC, PN 812544-801  | Modulator Test Set TS-4092/URC   |

Table 1-6. Related Technical Manuals - Continued

| Publication no.  | Publication title   | Equipment nomenclature   |
|------------------|---|--|
| TO 33D7-50-720-1 | Operation and Maintenance Instructions with Illustrated Parts Breakdown, Test Adapter OF-117/U, PN 707258-801                                       | Test Adapter OF-117/U  |
| TO 33D7-36-51-1  | Operation and Maintenance Instructions with Illustrated Parts Breakdown, RT-1319 Receiver Test Set TS-4091/URC, PN 812539-801                       | RT-1319 Receiver Test Set TS-4091/URC                                |
| TO 33D7-33-190-1 | Operation and Maintenance Instructions with Illustrated Parts Breakdown, Multi-Module Test Set TS-4094/URC, PN 812541-801                           | Multi-Module Test Set TS-4094/URC                                    |
| TO 33D7-33-191-1 | Operation and Maintenance Instructions with Illustrated Parts Breakdown, Transmitter Module Test Set TS-4093/URC, PN 812542-801                     | Transmitter Module Test Set TS-4093/URC                              |
| TO 33D7-71-46-1  | Operation and Maintenance Instructions with IPB, Radio Test Set AN/GRM-115, PN 707257-801   | Radio Test Set AN/GRM-115  |
| TO 33D7-71-47-1  | Operation and Maintenance Instructions with IPB, Radio Test Set AN/GRM-116, PN 707291-801 and Receiver-Transmitter Test Set AN/GVM-9, PN 707293-801 | Radio Test Set AN/GRM-116 and Receiver-Transmitter Test Set AN/GVM-9 |
| TO 33D7-71-48-1  | Operation and Maintenance Instructions with IPB, Depot Level, SDU Audio Boards Test Set, TS-4132/GRC-206(V), PN 707297-801                          | SDU Audio Boards Test Set, TS-4132/GRC-206(V)                        |

Table 1-6. Related Technical Manuals - Continued

| Publication no. | Publication title   | Equipment nomenclature                       |
|-----------------|---|--|
| TO 33D7-71-49-1 | Operation and Maintenance Instructions with IPB, Depot Level, Test Set, Unified Radio Set Control TS-4133/GRC-206(V), PN 707296-801 | Unified Radio Set Control TS-4133/GRC-206(V) |

## CHAPTER 2

## INSTALLATION

2-1. GENERAL. This section is not applicable to the depot level. Refer to TO 31R2-2GRC206-2 for this information if needed.

## CHAPTER 3

## PREPARATION FOR USE AND RESHIPMENT

3-1. INTRODUCTION. This chapter contains information on the preparation for reshipment for Radio Communication Systems AN/GRC-206(V)1 and AN/GRC-206(V)2. Preparation for Use is not included in this manual. See TO 31R2-2GRC206-2 for information on preparation and use.

3-2. GENERAL. This chapter contains instructions for reshipment of systems AN/GRC-206(V)1 and AN/GRC-206(V)2.

3-3. PREPARATION FOR RESHIPMENT. Prepare the Radio System for shipment in accordance with the following paragraphs.

a. Methods and Conditions of Reshipment. If shipment of the Radio System is required, normal packing and shipping precautions should be observed. Carefully pack the equipment in the original shipping containers, if available. Brace the equipment in the same manner that the equipment was originally shipped. Refer to figures 3-1 through 3-4 for typical packing and unpacking procedures.

b. Disassembly Required for Reshipment. For removal and disassembly procedures necessary to ship components/assemblies, refer to Chapter 5.

c. Use of Reusable Containers. If at all possible, Radio System components should be shipped in their original containers. Refer to the Radio System packing list which lists the original shipping containers and packed contents. Refer to figure 3-1 for component packing procedures and figure 3-2 for assembly packing procedures. Equipment mounts or brackets which only require physical or mechanical protection should be packed in accordance with figure 3-3. Refer to figure 3-4 for antenna and cable packing procedures.

d. Items Requiring Special Attention. Several components of the Radio System contain assemblies which require special handling. These assemblies contain devices which are sensitive to electrostatic discharge (ESD). Refer to table 3-1 which lists these components and their associated assemblies. Control measures contained in TO 00-25-234 should be observed during all handling or maintenance of these assemblies.

Table 3-1. Items Requiring Special Attention

| Unit/component   | Assembly Name  | Ref. Des. |
|--|--|-----------|
| Unit 1, Signal Distribution<br>Unit Control C-11169/GRC-206      | Audio Interface No. 1 CCA<br>(PN 812094-801)               | 1A1       |
|  | Audio Interface No. 2 CCA<br>(PN 812095-801)               | 1A2       |
|  | Red Interface CCA<br>(PN 812154-801)                       | 1A3       |
|  | Black Interface CCA<br>(PN 812117-801)                     | 1A4       |
|  | CPU CCA<br>(PN 812116-801)                                 | 1A5       |
|  | Fiber Optic Module<br>(PN 812099-801)                      | 1A8/1A9   |
| Unit 3, Radio Set<br>AN/URC-113                                  |  |           |
| Amplifier-Coupler<br>AM-7148/GRC-206                             | Control Logic Assembly<br>(PN 651-8463-001)                | 3A1A4     |
|  | Upper Electronic Equipment<br>chassis<br>(PN 651-8445-001) | 3A1A5     |
| Receiver-Transmitter<br>RT-1444/URC                              | Control Panel Module<br>(PN 755002A0440)                   | 3A2A1A4   |
|  | Remote Control Module<br>(PN 812130-801)                   | 3A2A1     |
| Unit 4, Electrical<br>Equipment Mounting Base<br>MT-6250/GRC-206 | FM BITE/Audio Interface<br>(PN 812132-801)                 | 4A1       |



Table 3-1. Items Requiring Special Attention - Continued

| Unit/component                                 | Assembly Name                                 | Ref. Des. |
|--|---|-----------|
| Unit 5/6, Radio Set<br>Control C-11166/GRC-206 | (See note)                                    |           |
| RSC Case Assembly<br>(PN 812092-801)           | Fiber Optic Module<br>(PN 812099-801 or -802) | 5A1A4     |
| RSC Panel Assembly<br>(PN 812120-801)          | Digital Interface CCA<br>(PN 812126-801)      | 5A2A1     |
|  | Audio Interface CCA<br>(PN 812133-801)        | 5A2A2     |

NOTE: Remove batteries from the RSC prior to shipment or storage for more than 30 days.

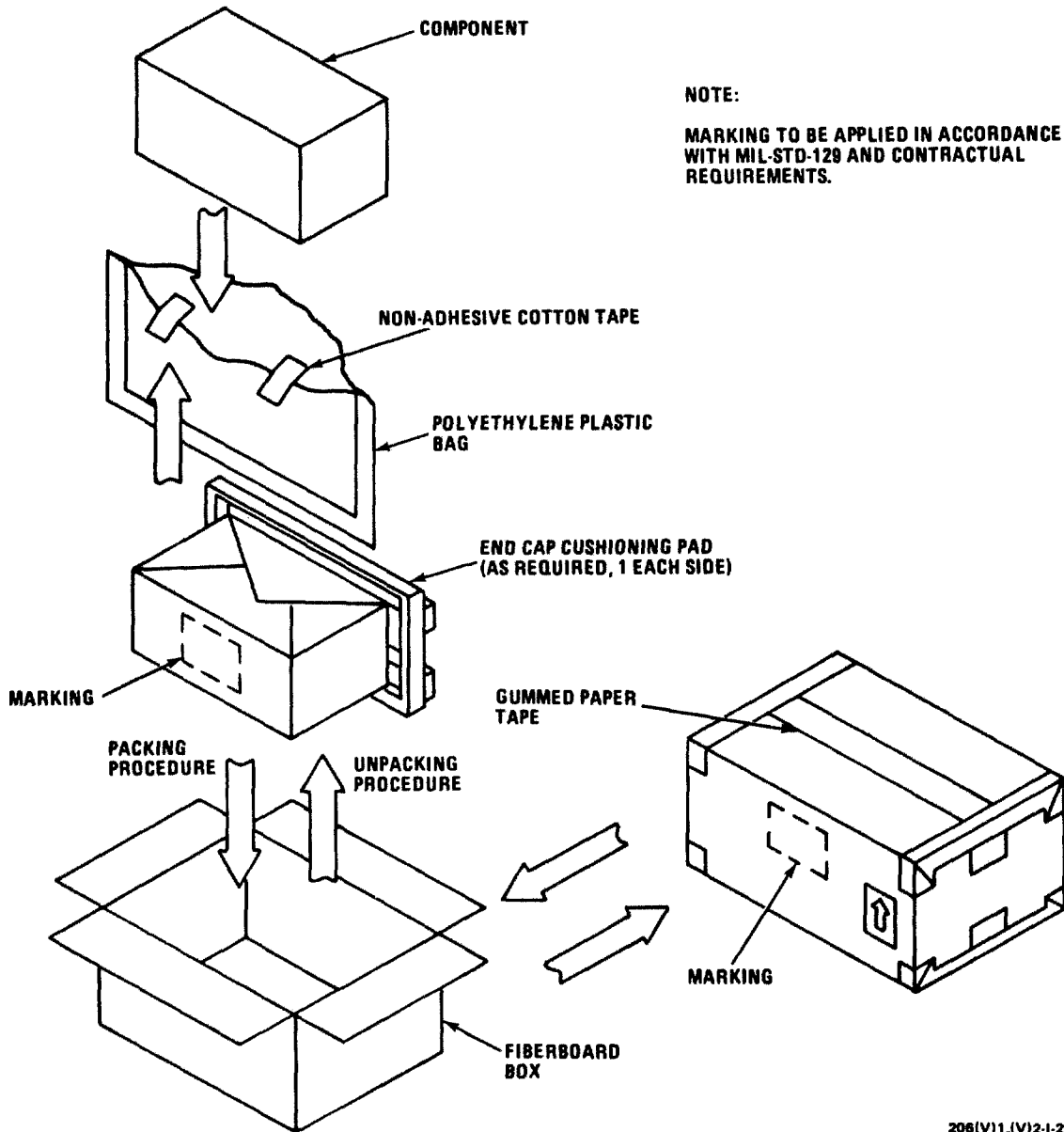

Figure 3-1. Component Packing and Unpacking

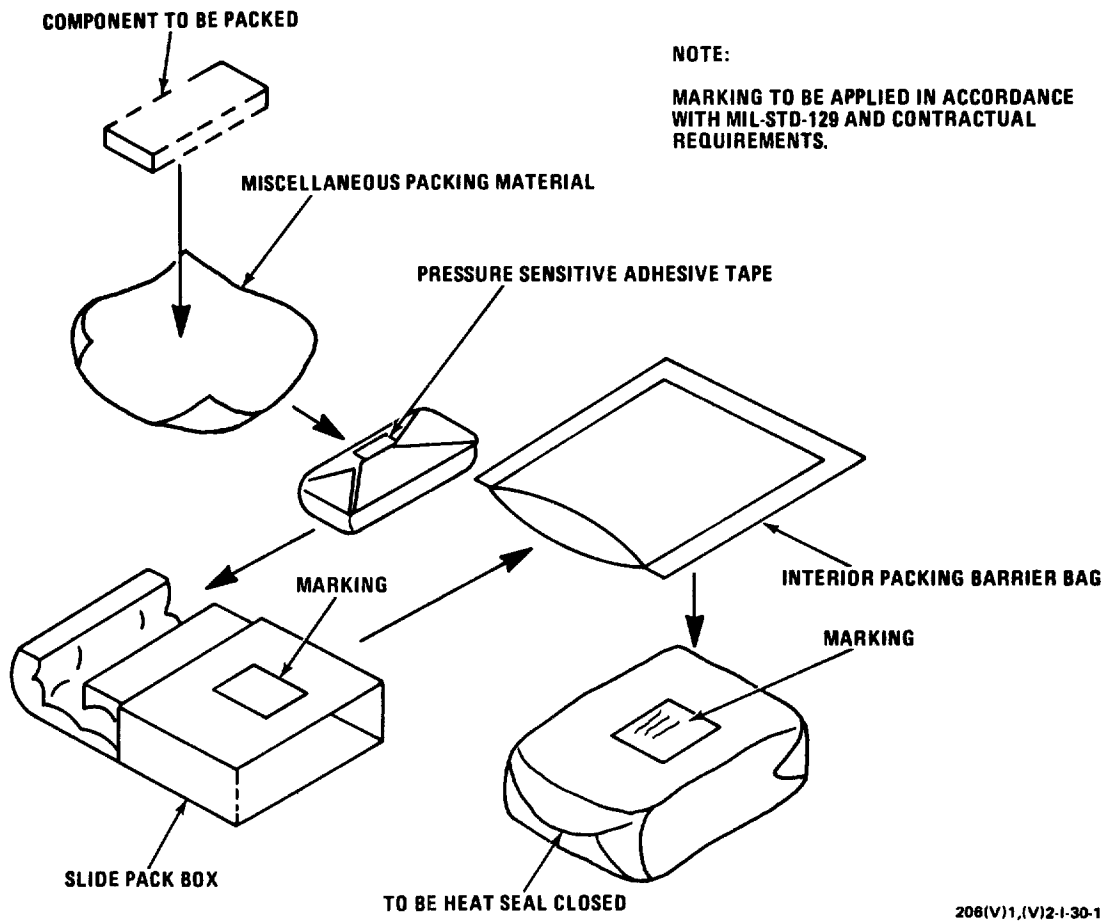
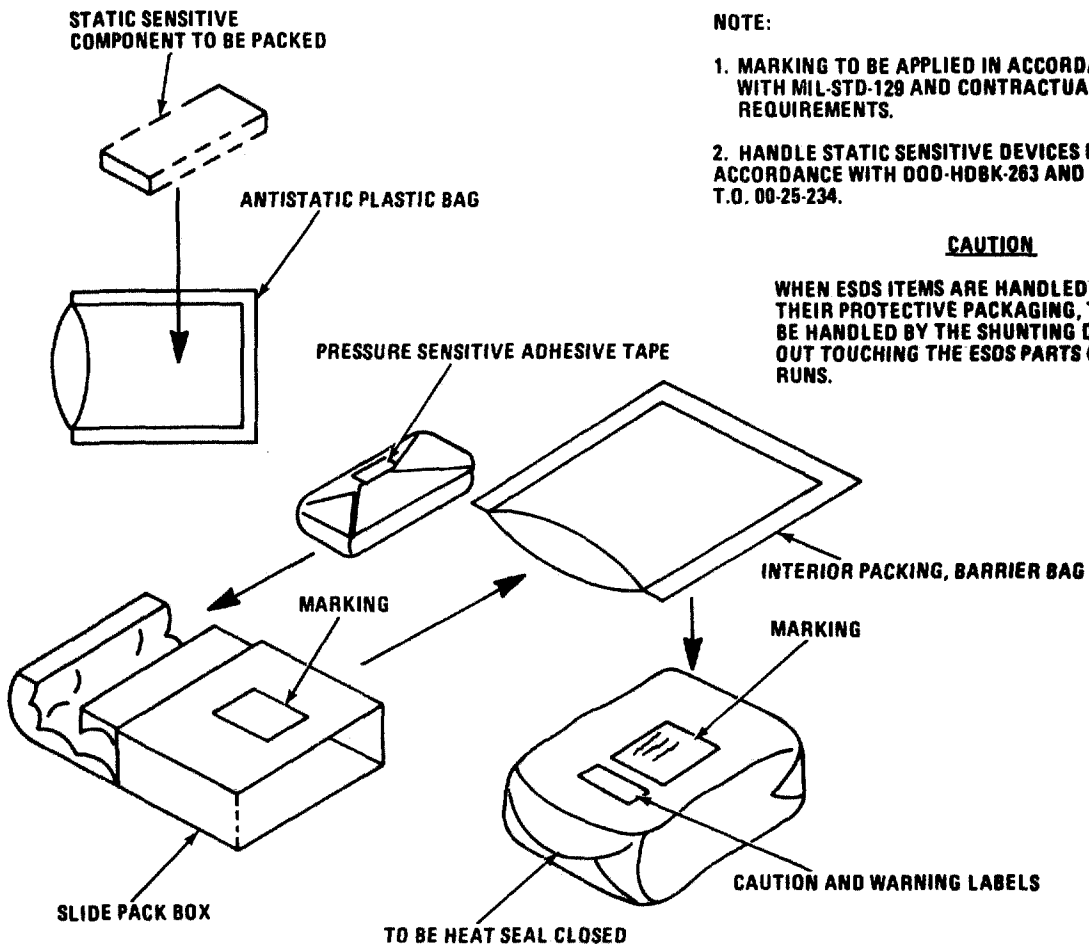
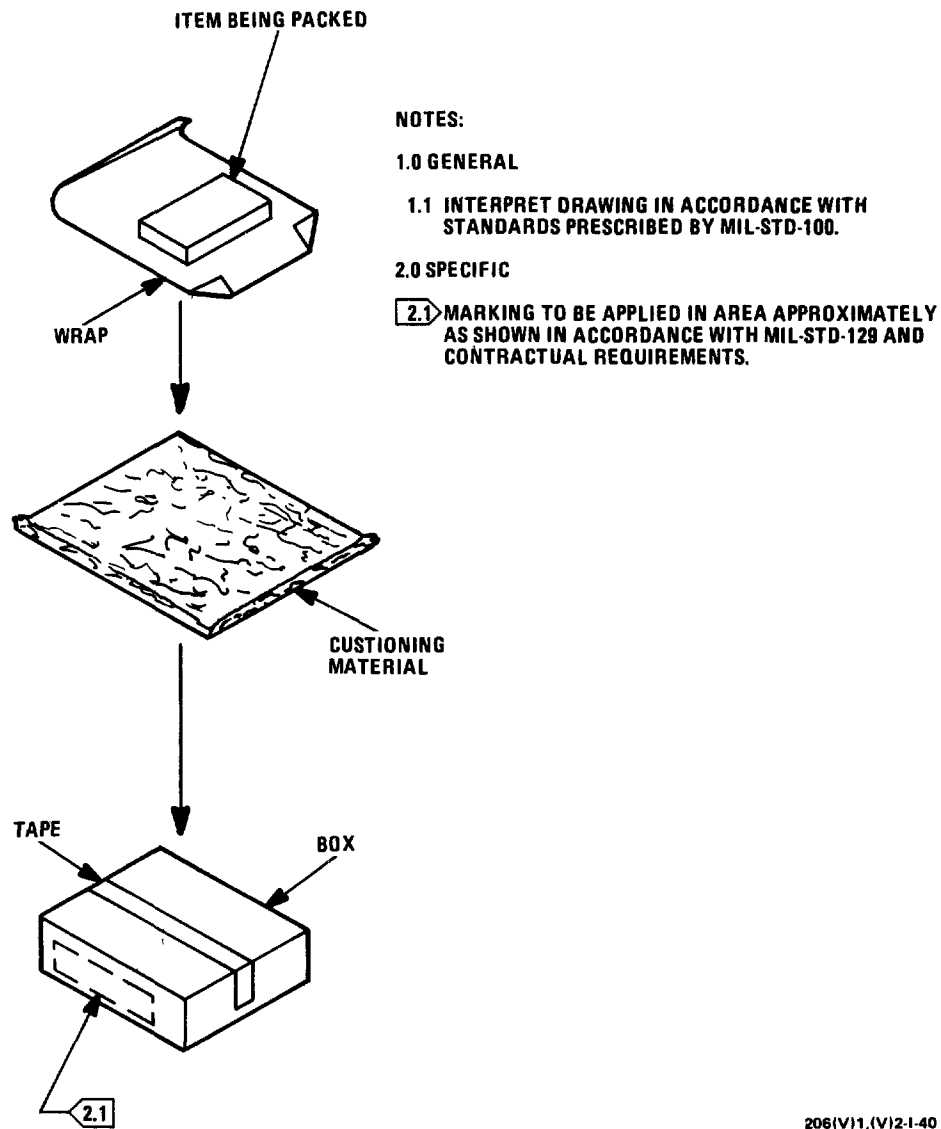

Figure 3-2. Assembly Packing and Unpacking (Sheet 1 of 2)



206(V)1, (V)2-1-30-2

Figure 3-2. Assembly Packing and Unpacking (Sheet 2 of 2)



206(V)1,(V)2-1-40

Figure 3-3. Typical Packing Instructions for Mechanical Items

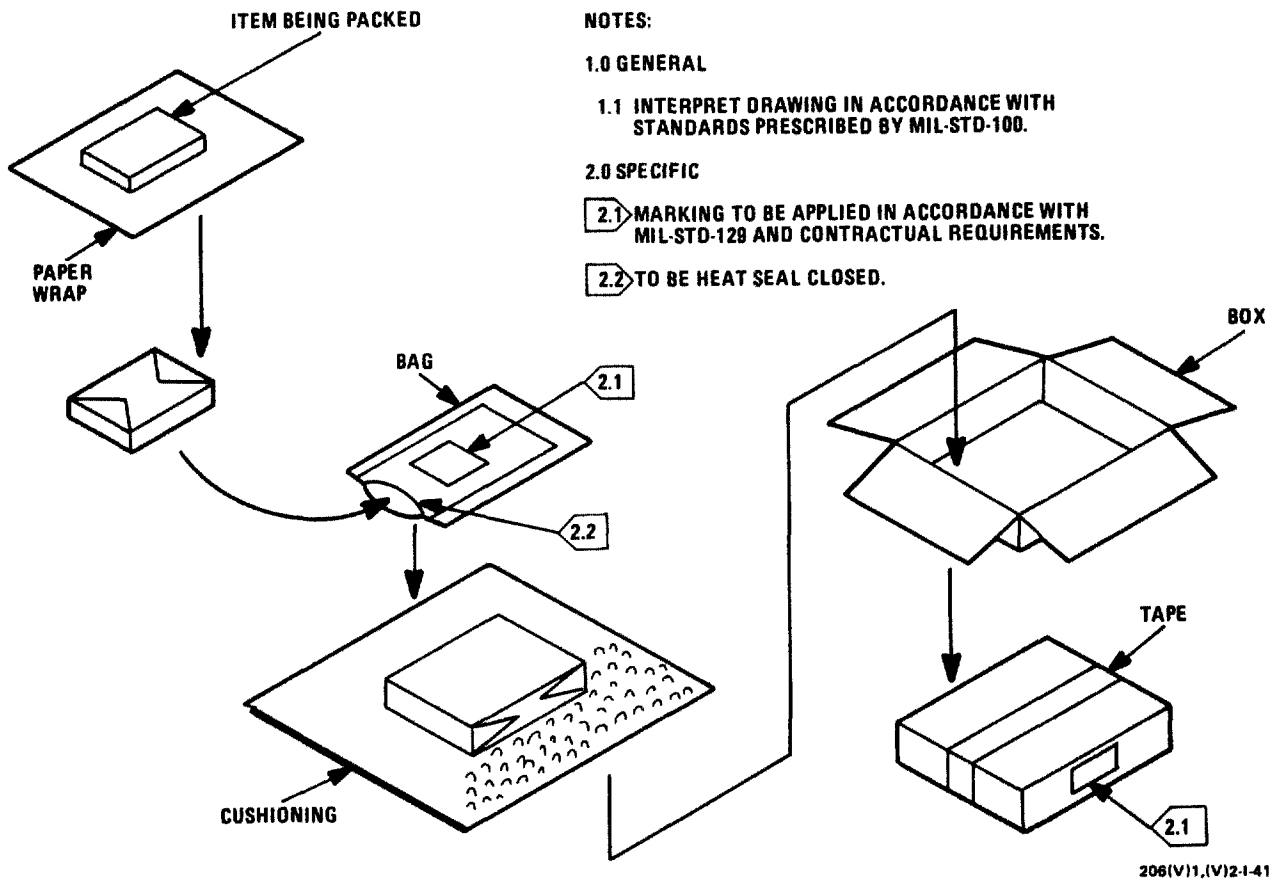

Figure 3-4. Typical Packing Instructions for Antennas and Cables

## CHAPTER 4

## THEORY OF OPERATION

4-1. INTRODUCTION. The theory of operation for Radio Communication Systems AN/GRC-206(V)1 and AN/GRC-206(V)2 is presented in this chapter. It supports depot level maintenance procedures in the subsequent chapter. The theory of operation is presented as a functional description of the radio communication system LRUs and, in turn, their SRU subassemblies and components.

## Section I. FUNCTIONAL SYSTEM OPERATION

4-2. GENERAL. This section contains a brief functional block diagram description of the Radio System. The discussion is based upon figure 4-1. To supplement the information in this section, refer to Chapter 1. Figure 1-1 shows the Radio System component locations, and table 1-3 lists the capabilities and limitations of the equipment. TO 31R2-2GRC-206-2 lists the equipment supplied with the Radio System and gives brief information on the equipment function.

4-3. RADIO SYSTEM FUNCTIONAL DESCRIPTION. The Radio System consists of the following equipment: a power switchboard which selects and distributes primary power for use by Radio System components, an SDU which processes and controls the flow of information between the radio sets and the radio set control (RSCs), two RSCs which provide operator interface and control of the entire Radio System, and four radio sets (and associated antennas) which provide receive and transmit capabilities in three communication bands (HF, VHF, and UHF). In addition, voice ciphering equipment may be connected in the audio path of either radio set to provide secure voice operation of the associated radio set. The following paragraphs provide a functional description of the Radio System major components.

a. Power Distribution. Primary power for the electronic equipment in the Radio System is generated by one of two supplies. One is the vehicle power generating system and the other is a gasoline engine generator. Primary power is routed to the power switchboard via two separate power cables. At the power switchboard, source power is selected and conditioned for distribution. The conditioned power is distributed via a power junction unit (PJU) which is hard-mounted to the rear of the power switchboard mount. Separate power cables from the (PJU) distributes the conditioned +28 VDC power to each LRU installed in the equipment mounting rack.

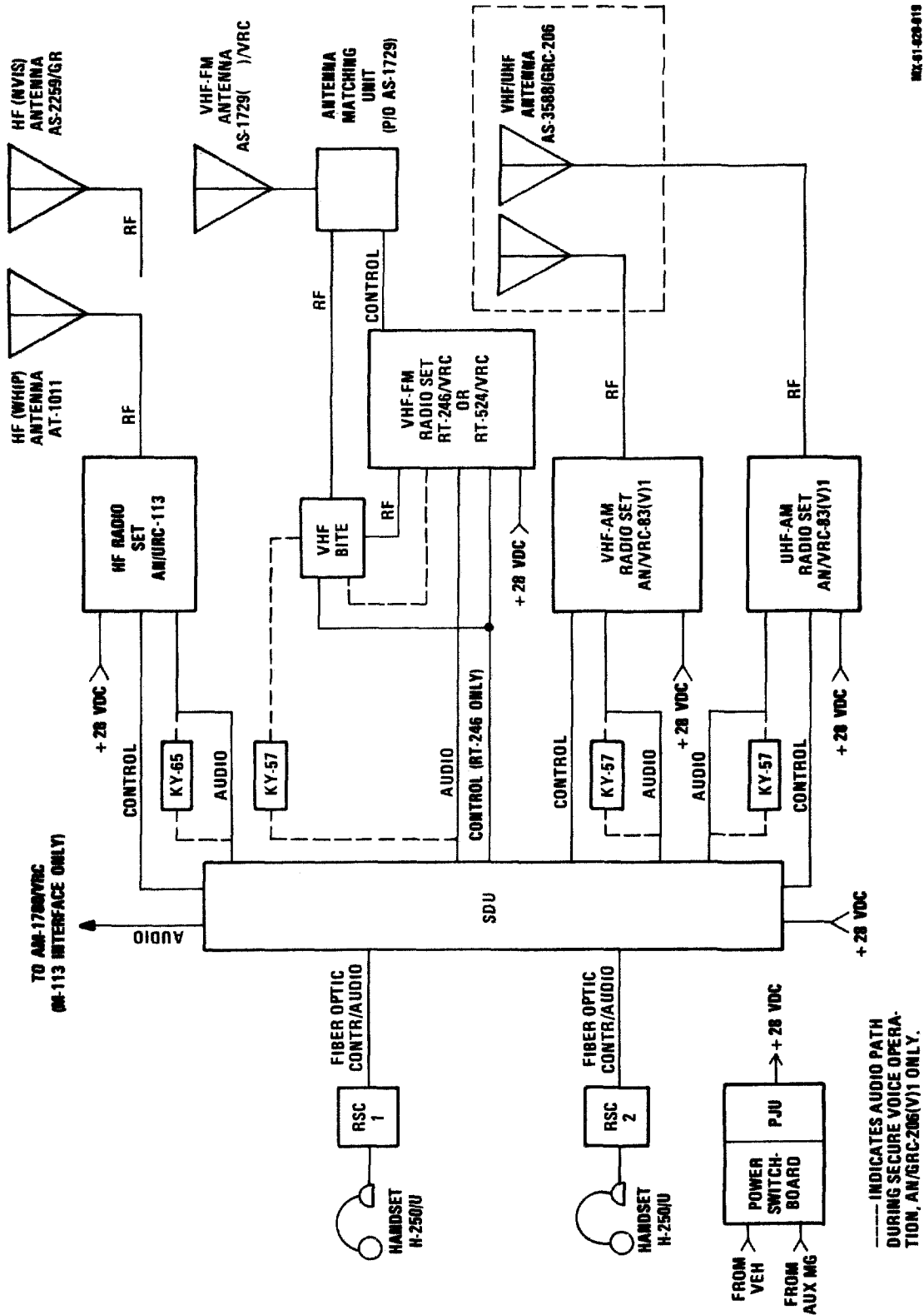

REF: 41-208-818

Figure 4-1. Radio System Simplified Block Diagram



b. RSC-SDU Interface. Control of the entire Radio System (in the normal mode of operation) is accomplished via the RSC-SDU interface which consists of the SDU, F/O cables, and one or two RSCs. Two RSCs are supplied with each Radio System to provide audio and control I/O capabilities in either of the following configurations: one operator at either or both RSCs or two operators at either (but not both) RSC.

(1) Transmit Operation. During transmit operation, digitized audio and control information for the selected RF subsystem is routed from the RSC to the SDU via the transmit (XMT) line of the F/O cable. The information received by the SDU is decoded and processed for output to the selected RF subsystem as conventional control and audio signals. The control and audio signals are routed from the SDU to the appropriate radio set via separate control and audio cables.

(2) Receive Operation. During receive operation, audio signals from the receiving radio set are routed to the SDU. The audio signal, received by the SDU, is digitized and coded for output to the RSC. The coded information is routed from the SDU to the RSC via the receive (RCV) line of the F/O cable. The information received by the RSC is decoded and routed to the appropriate front-panel AUDIO connector, display, or fault indicator.

c. HF Radio Set Operation. The HF radio set is composed of two major components: Receiver-Transmitter RT-1444/URC (RT-1444) and Amplifier-Coupler AM-7148/GRC-206 (AM-7148). The HF radio set provides HF-SSB communications from 2.0000 to 29.9999 MHz and operates on any one of 280,000 frequency channels. The RT-1444/URC is a modified RT-1209/URC. The RT-1444 provides RF drive, frequency selection, operating mode selection RT, power on/off, and squelch control. The AM-7148 basically provides amplification for HF transmission signals and automatic tuning of the installed antenna to impedance-match the 50 ohm resistive output of the power amplifier. The AM-7148 also provides fault sensing with a display circuit to visually indicate the unit/assemblies causing failures.

(1) Transmit Operation. Transmit operation is started by a push-to-talk (PTT) signal that originates from the handset. During transmit operation, the audio and PTT signal from the SDU (KY-65, during secure voice transmissions) is routed to the front-panel AUDIO connector on the RT-1444. The RT-1444 produces an HF-SSB drive input up to 157 milliwatts. This drive is amplified to a peak power of 150 watts by amplifiers within the AM-7148. The RF signal is coupled to the antenna through the low-pass filter assembly to the antenna tuner assembly. A discriminator assembly circuit provides DC analog signals to a control logic assembly that controls antenna tuning sequence and impedance-matching to the antenna. These DC analog signals are developed from magnitude and phase angle relationships of the RF voltage and current monitors.

#### NOTE

If any fault is detected in the HF radio set, a visual fault indication and audible alarm (intermittent two-tone signal) will be present at the RSC.

(2) Receive Operation. The radio subsystem is in the receive mode at any time the PTT signal is not present. During receive operation, the transmit/receive relay

in the low-pass filter assembly is in the receive position, and signals at the antenna are coupled to the RT-1444 through the antenna tuner assembly. The RT-1444 demodulates the RCV RF and converts it to RCV audio. The RCV audio is applied through an audio filter to the audio amplifier circuitry. This amplified audio is routed to the front panel AUDIO connector. The RCV audio is routed from the RT-1444 to the SDU (KY-65, during secure voice reception) for output to the RSC and to the front panel of the AM-7148 for application to the local speaker.

d. VHF-FM Radio Set Operation. RT-246/VRC or RT-524/VRC is used to provide VHF-FM communications from 30.00 to 75.95 MHz and operates on any one of 920 frequency channels. The receive and transmit audio paths are identical from both RTs. A VHF-FM detect circuit is used to sense the type VHF-FM radio installed in the Radio System. This signal is used by the RSC-SDU interface to provide the appropriate RSC display and control functions during VHF-FM operations.

(1) Transmit Operation. During transmit operation, XMT audio signals are routed from the SDU (VHF BITE during secure voice operation) and applied to the front-panel RETRANSMIT R/W connector. The XMT RF from the RT is routed to the VHF BITE panel which monitors the RTs RF output power for losses greater than -3 dB. The XMT RF is then routed to the VHF-FM antenna.

NOTE

If the RF output from the transmitter drops below a specified level, a fault indication will be present at the RSC.

(2) Receive Operation. During receive operation, the RCV RF is routed from the antenna through the VHF BITE panel to the RT. During nonsecure voice operation, the RCV audio signal from the RT is routed to the SDU and then to the RSC for operator input. During secure voice operation, the RCV audio signal from the RT is routed through the VHF BITE and applied to voice ciphering equipment KY-57, then routed to the SDU.

e. VHF/UHF-AM Radio Set Operation. Radio Set AN/VRC-83(V)1 is used to provide VHF/UHF-AM communications for the Radio System. The VHF-AM radio set provides communications from 116.000 to 149.975 MHz and operates on any one of 1350 frequency channels. The UHF-AM radio set provides communications from 225.000 to 399.975 MHz and operates on any one of 7000 frequency channels. The UHF-AM radio set is also capable of guard receiver operation at the input frequency of 243.000 MHz. Refer to TO 31R2-2VRC83-2 for the detail description of AN/VRC-83(V)1. The receive and transmit signal paths are similar for both AN/VRC-83(V)1 applications in the Radio System; therefore, only one description is given.

(1) Transmit Operation. During transmit operation, XMT audio signals are routed from the SDU (KY-57, during secure voice operation) and applied to the RT-1319 AUDIO connector. The XMT RF from the RT-1319 is applied to the AM-7176 which is capable of amplifying the RF to 30 watts when its front-panel switch is in the PA position. Regardless of the selected RF power output, the XMT RF is routed from the AM-7176 and applied to the appropriate (UHF or VHF) port on the UHF/VHF antenna.

## NOTE

If the RF output from the transmitter drops below a specified level, a fault indication will be present at the RSC.

(2) Receive Operation. During receive operation, the RCV RF is routed from the associated UHF/VHF antenna port and applied to AM-7176 ANT connector. The RCV RF is then routed from the AM-7176 to the RT-1319 ANT connector. Internal to the RT-1319, the audio is removed from the RF signal and routed from the RT-1319 AUDIO connector as RCV audio. The RCV audio is then routed to the SDU (KY-57, during secure voice reception) and to the RSC(s).

## Section II. DETAILED THEORY OF OPERATION

4-4. SCOPE. This section describes the operation of electronic circuitry and components that are repairable at depot level maintenance. Electronic circuits described are: the SDU electrical equipment chassis, SDU audio interface (1), SDU audio interface (2), SDU red interface, SDU black interface, SDU CPU, SDU power supply subassembly, SDU F/O module assembly, radio set control (RSC), RSC audio interface, RSC digital interface, RSC regulator, and FM BITE/audio interface assembly.

4-5. ELECTRICAL EQUIPMENT CHASSIS. The electrical equipment chassis and other components make up the power switchboard circuitry, which provides protection against transient voltage spikes and overvoltage conditions. It also provides isolation between the vehicle input (J4) and the auxiliary generator input (J5). See FO-1 for the schematic diagram of the power distribution unit.

a. Input Power. Input power to the power switchboard is +22.5 to +30.0 VDC. The input power can be from either the vehicle electrical system or the auxiliary generator. Switch S1 selects the power source. In the AUX MOTOR GEN position, relay K1 is not energized, and the +28 VDC line from the auxiliary generator connector J5-A is selected. When S1 is in the VEHICLE position, K1 is controlled by the RUN/RUN # input J4-D. When RUN is present at J4-D (RUN/RUN # is ground), K1 is energized, closing contacts A1 - A2. Input voltage from J4 is then supplied to the power switchboard. When RUN # is present at J4-D (RUN/RUN # is open), K1 is not energized, closing contacts A3 - A4, thus inhibiting the use of vehicle power. When S1 is in the VEHICLE OVERRIDE position, K1 is energized, closing contacts A1 - A2 regardless of the RUN/RUN # status. The VEH OVRD indicator DS2 (amber lens) lights, indicating that vehicle battery power is being used by the Radio System.

b. Power Source Selection. In the system power circuit, the power selected by S1 is applied to zener diode CR1 and circuit breaker CB1 to protect against sustained overvoltage and reversed polarity. S1 also turns power to the Radio System on or off. When CB1 is reset and a functioning power source is selected by S1, the PWR ON indicator DS1 (green lens) lights, and the input voltage level is indicated by meter M1. CR5 provides transient spike and overcurrent protection; it limits transient overvoltages to +51 VDC maximum. EMI protection is provided by a filter consisting of L1, C1, and R1. Filtered system power is available at connector J6.

c. Accessory Connectors. Accessory connectors J1 and J2 and binding posts E1 through E6 receive power from K1 through circuit breakers CB3 (J1 and J2) and CB2 (E1 through E6). No-break power from isolating diodes CR2 and CR3 supplies positive voltage to K1 and to connector J3 (not used in (V)1 or (V)2 Radio Systems). In addition to isolating the two power input sources, CR2 and CR3 also act as fuses for loads connected to J3.

4-6. SDU AUDIO INTERFACE (1) CCA. The audio interface (1) CCA interfaces the RSC1 and RSC2 fiber optic links with the SDU. Two UARTs (one for RSC1 and one for RSC2) convert serial information from the RSCs to parallel information for use by the SDU circuits and vice-versa. Audio interface (1) also provides analog-to-digital (A/D) conversion for the UHF-AM and VHF-AM receive audio, and digital-to-analog (D/A) conversion for the UHF-AM and VHF-AM transmit audio. Audio routing circuits also select the proper transmit audio source (RSC1 or RSC2) for the UHF-AM and VHF-AM subsystems. Audio interface (1) also contains an intercommunication (IC) circuit using an audio isolation transformer with balanced output. This additional isolation is necessary because the IC audio line is routed outside the Radio System to the VIC-1 intercom (M-113 vehicle only). All audio signals and key lines for the five subsystems (HF, VHF-FM, VHF-AM, UHF-AM, and IC) are interfaced through connector J1. Connectors J2 and J3 provide the interface for RSC2 and RSC1, respectively, via the associated fiber optic module. Refer to block diagram figure 4-2, and schematic diagram FO-2 during the circuit descriptions.

a. Analog-to-Digital Conversion. The VHF-AM and UHF-AM A/D conversion circuits are essentially identical. Receive audio from the VHF-AM and UHF-AM subsystems is supplied to the CCA at J1-23 (VHF-AM AUDIO IN) and J1-20 (UHF-AM AUDIO IN). The input audio signals are then sent to buffer-amplifier circuits using amplifiers as pass-filters U27A (VHF-AM) and U17A (UHF-AM). The outputs of these amplifier circuits are supplied to the ANLG IN inputs of CVSD (continuously variable slope delta) modems U26 (VHF-AM) and U20 (UHF-AM) for A/D conversion. These CVSD modems are clocked at the 25 kHz XMT CLK rate. A 50 KHZ # clock line is present but unused. The clock is chosen by a selection circuit using NAND gates U25 A through D (VHF-AM) and U19A A through D (UHF-AM), and inverting buffers U18C (VHF-AM) and U18B (UHF-AM).

When the data port enable line to the clock selection circuit is low, the 25 kHz XMT CLK is selected. When the data port enable line is high, the unused 50 kHz clock line is selected. The selected clock line can be disabled by a low on its respective squelch indicator line (VHF-AM SQL IND or UHF-AM SQL IND). The digitized audio from the CVSD modem is supplied to the appropriate transmit bus (TB) line of both UARTs for transmission to the RSCs. The VHF-AM digitized audio goes to TB2 and the UHF-AM goes to TB3 of the UARTs.

b. Digital-to-Analog Conversion. Transmit audio to the VHF-AM and UHF-AM subsystems can be supplied from either RSC. Transmit audio from the RSCs is obtained from the receive bus of that RSCs UART (U3 for RSC1, U6 for RSC2). Digitized audio from each of the UARTs goes to a selection circuit, which chooses the audio source (VHF-AM (1) or VHF-AM (2) for the VHF-AM subsystem, UHF-AM (1) or UHF-AM (2) for the

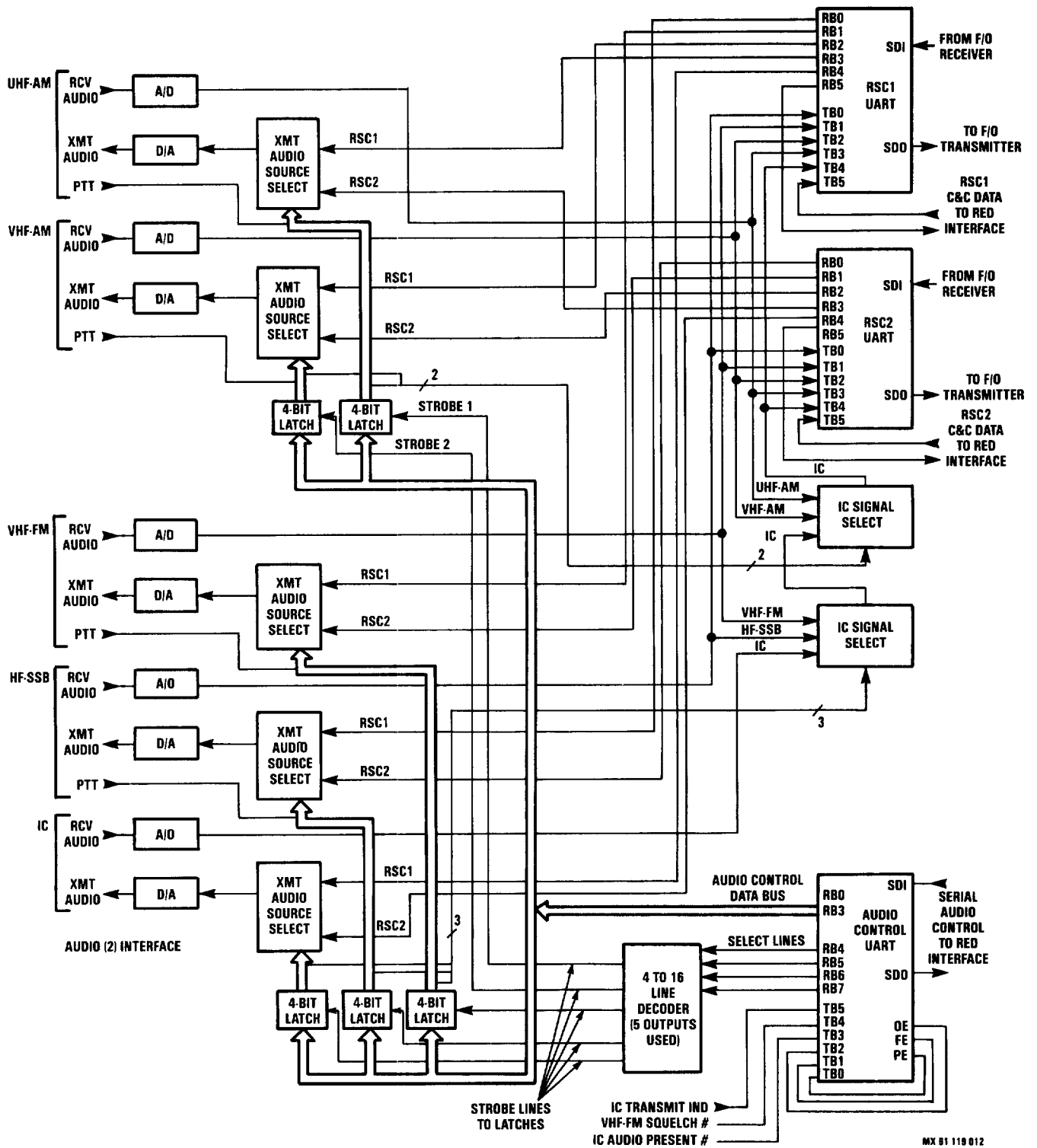

Figure 4-2. SDU Audio Interface (1) 1A1 and (2) 1A2 Block Diagram

UHF-AM subsystem) to be used as transmit audio. This selection circuit also chooses a clock line synchronized with the UART supplying the audio, which can be either a 25 kHz or the unused 50 kHz clock line. These clock signals (25 KHZ (1), 25 KHZ (2)), are generated by the clock synchronization circuit.

The audio source/clock selection circuit can also alternate the selected audio source with the DIGITIZED IC AUDIO when in the DCT mode. The audio source/clock selection circuits for the VHF-AM and UHF-AM are identical, except that every other digitized audio signal from the RSCs is inverted in the VHF-AM circuit. The switching in these circuits is done by digitally controlled analog switches (U22 and U23 for the VHF-AM, U14 and U15 for the UHF-AM).

When the PTT # line is high, the digitized audio and clock lines to the CVSD modem are disabled by the inhibit lines to the analog switches. When the PTT # line is low, the digitized audio and clock signals are supplied to the CVSD modem. The transmit source select control lines (VHF-AM SOURCE SEL and UHF-AM SOURCE SEL) control the switches which select the source of transmit audio (RSC1 or RSC2) and the proper clocks (25 KHZ (1) and unused 50 KHZ (1) or 25 KHZ (2) and unused 50 KHZ (2)). When the SOURCE SEL line is high, the digitized audio and clocks from RSC2 are selected. When the SOURCE SEL line is low, the audio and clock lines from RSC1 are selected. The data port enable lines (VHF-AM DATA PORT ENBL and UHF-AM DATA PORT ENBL) when low, select the 25 kHz clock line for the CVSD modem and select the digitized audio from the chosen RSC as input to the CVSD modem. When the data port enable line is high, the RSC digitized audio/IC digitized audio switch control line (pin 11 on U23 for VHF-AM, U15 for UHF-AM) is connected to a 25 kHz clock line. This causes the input to the CVSD modem to alternate between the IC and the RSC data. A high on the data port enable line also changes the CVSD modem's clock to 50 kHz. The CVSD modems (U24 for VHF-AM, U16 for UHF-AM) are used for D/A conversion only. The digitized audio from the selection circuit is supplied to the DATA IN input, pin 13. The selected clock is supplied to the CLK input, pin 14. The analog output (ANLG OUT, pin 7) is then filtered (by U27B and associated circuitry for VHF-AM, U17B and associated circuitry for UHF-AM). The output of each filter is supplied to the transmit audio line of its respective subsystem through J1 (VHF-AM TRANSMIT AUDIO line at J1-24, UHF-AM TRANSMIT AUDIO line at J1-19).

c. UART Circuitry. The RSC1 UART (U3) and the RSC2 UART (U6) circuits are identical. The digitized receive audio from the various subsystems is applied to the transmit bus of both UARTs as follows:

|     |        |
|-----|--------|
| TB0 | HF-SSB |
| TB1 | VHF-FM |
| TB2 | VHF-AM |
| TB3 | UHF-AM |
| TB4 | IC     |

The TB5 bit of U6 is used for RSC2 command and control (C&C) transmit data from P1-7. The TB5 bit of U3 is used for RSC1 C&C transmit data from P1-5. The serial data from the UARTs SDO output (pin 25) goes to an amplifier (U1C for RSC1, U5B for RSC2) and then to the F/O transmitter through J3-4 (RSC1) and J2-4 (RSC2). Data from the F/O link is received at J3-5 (RSC1) and J2-5 (RSC2). The receive data is amplified (by U1B for RSC1, U5A for RSC2) and supplied to the SDI input (pin 20) of the proper

UART. The receive bus outputs RBO through RB4 provide digitized transmit audio which is routed to the various subsystems through the D/A conversion circuits. These audio lines are suffixed (1) or (2), depending on whether their source was RSC1 or RSC2. The receive lines are arranged in the same order as the transmit lines (RBO is HF-SSB, RB1 is VHF-FM, etc.). The RB5 line is used for C&C data. Data from the RB5 lines is sent to the red interface CCA through amplifiers U1B (RSC1) and U5C (RSC2) and connectors P1-6 (RSC1) and P1-11 (RSC2). Receive bits RB6 and RB7 are not used. The receive and transmit clocks (R CLK and T CLK) of the UARTs receive a 3.2 MHz clock signal from oscillator U4. The output of U4 is supplied to P1-39 (3.2 MHZ OUT) and looped back to P1-9 (3.2 MHZ IN). The 3.2 MHz receive and transmit clock rates correspond to 200 kbps. Transmit timing is provided by the XMT CLK line, which is a 200 kbps T CLK line from binary counter U8. (Binary counter U8 also provides the 100 kHz and 50 kHz signals used in the CCA.) The XMT CLK line is used to signal the transmitter holding register load (THRL #) line of the UART to load the next word for transmission. When a word is received by one of the UARTs, the data available (DA) line goes high. The DA signal passes through a NOR gate (U7A for the RSC1 UART, U7B for the RSC2 UART), provided the data available reset (DAR #) line is high. If the DAR # line is low when the DA line goes high, an overrun condition exists. The inverted DA signal from the NOR gate is input to shift register U9A (RSC1 UART) or U9B (RSC2 UART) and is shifted out after four cycles of the 3.2 MHz clock (1.25 us). When the shift register output (DAR # signal) goes low, the DA signal to the shift register input is disabled. These events produce a 1.25 us low pulse on the DAR # line, clearing the data available flip-flop for the next word of data.

d. Clock Synchronization Circuits. These circuits provide 50 kHz and 25 kHz clocks which are synchronized with the UARTs for use by the CVSD modems in the D/A conversion circuits. The DA (data available) line from each UART is supplied to the reset input of two flip-flops (U10A and U10B for DA (1), U11A and U11B for DA (2)). A 100 kHz clock signal is supplied to the inputs of U10A and U11B, which are set up in a divide-by-two configuration. The Q outputs of U10A and U11B provide an unused 50 kHz signal with a rising edge synchronized with the DA (1) and DA (2), respectively. The unused 50 KHZ (1) and 50 KHZ (2) signals from U10A and U10B are cascaded into U10B and U11A, respectively, in a divide-by-two configuration to produce the 25 KHZ (1) and 25 KHZ (2) signals.

e. PTT Buffers. The PTT # lines for the various subsystems are sent through buffers on the audio (1) CCA before leaving the SDU. The VHF-AM PTT # signal, used on the audio interface (1) CCA, is supplied to inverting buffer U12E, from there to buffer U13G, and from there to connector J1-7. The UHF-AM PTT # line (also used on audio (1) CCA) has a similar buffer circuit, which used U12D, U13F, and outputs at connector J1-8. The VHF-FM PTT #, IC PTT #, and HF-SSB PTT # lines (used on the audio interface (2) CCA) are supplied to the audio interface (1) CCA at connectors P1-55, P1-56, and P1-57, respectively. The VHF-FM PTT circuit is also similar to the VHF-AM circuit and uses U12A, U13B, and outputs at connector J1-4. The VHF-FM PTT circuit uses U12A, U13B, CR5 (for overvoltage protection), and outputs at J1-5. The HF-SSB PTT circuit uses U12C, U13D, and a switching circuit consisting of Q1, CR1, CR2, and R19. This circuit provides compatibility with PTT circuits within the HF-SSB subsystem. Output for this circuit is at J1-6.

f. Audio Control Line Latches. The source select, data port enable, PTT, and squelch indicator signals are presented to the inputs of latches U21A and U21B by

the RB0, RB1, RB2, and RB3 lines, respectively. When the STROBE 1 line goes low, the RB line signal levels are latched into U21A, which holds the UHF-AM control information. When the STROBE 2 line goes low, the RB line signal levels are stored in U21B, which holds the VHF-AM control information.

g. IC Transmit Indicator Circuit. The A1 TRANSMIT KEY and A2 TRANSMIT KEY lines from the AM 1780/VRC (M-113 vehicle only) are presented to the audio interface (1) CCA at connectors J1-21 (A2) and J1-22 (A1). A low level on either line forward biases diode CR3 or CR4, which pulls the input of buffer U13A (normally pulled high by R95) low. The output of U13A is the IC TRANSMIT IND line, which leaves the audio interface CCA at P1-23.

h. Fiber Optic Power Filtering. The +12 VDC power to the F/O modules is routed through the audio interface (1) CCA. Inputs to the audio interface (1) CCA are P1-45 for the +12 V(1), and P1-46 for the +12 V(2) line. The +12 V(1) and +12 V(2) lines are supplied directly to the F/O modules through J3-2 and J2-2, respectively. The +12 VDC lines are filtered for use by the F/O receivers. The +12 V(1) line is filtered by an LC circuit consisting of capacitors C37 through C39 and inductors L9 and L10. The +12 V(2) line is filtered by an LC circuit consisting of capacitors C34 through C36 and inductors L7 and L8. The filtered +12 V(1) line is output to the RSC1 F/O module at J3-10, with ground at J3-7. The filtered +12 V(2) line is output to the RSC2 F/O module at J2-10, with ground at J2-7.

4-7. SDU AUDIO INTERFACE (2) CCA. The audio interface (2) CCA provides (A/D) conversion for the VHF-FM, HF-SSB, and IC receive audio to be sent to the RCSs. It also provides analog (D/A) conversion for transmit audio received from the RSCs, used by the same subsystems. Audio routing circuits select the proper transmit audio source (RSC1 or RSC2) for the VHF-FM, HF-SSB, and IC subsystems. The audio interface (2) CCA also decodes the A/D and D/A audio control information (sent serially from the red interface CCA) used on both the audio interface (1) and audio interface (2) CCAs. Refer to block diagram figure 4-2, and schematic diagram FO-3 during the circuit descriptions.

a. Analog-to-Digital Conversion. The VHF-FM and HF-SSB A/D circuits are identical in operation with the A/D circuits on the audio interface (1) CCA. The VHF-FM A/D circuit uses U26B as an input buffer/amplifier, U11D and U27A through U27D in the clock selection circuit, and CVSD modem U28. The HF-SSB A/D circuit uses U19B as an input buffer/amplifier, U20C and U21A through U21D in the clock selection circuit, and CVSD modem U22. The IC A/D circuit is also similar to the A/D circuits on the audio interface (1) CCA, but the IC A/D circuit does not have the clock selection circuit. The TRANSMIT CLOCK line is supplied to the CLK input of U4 (the CVSD modem used in the IC A/D circuit) through NAND gate U2C. The CVSD modem U4 receives the inverted TRANSMIT CLOCK signal when the IC SIDETONE/RCV CONT control line is high. The audio input buffer/amplifier uses U5B. Digital output from the IC A/D circuit is through inverting buffer U2D. The digitized audio outputs from the A/D conversion circuits are supplied to the transmit bus of the communications UARTs on the audio interface (1) CCA. The HF-SSB digitized audio goes to TB0; the VHF-FM, to TB1. The IC signal is supplied to the intercom signal select circuits on the audio interface (1) and audio interface (2) CCAs.



b. Digital-to-Analog Conversion. The operation of the VHF-FM and HF-SSB A/D circuits is identical to the VHF-AM D/A circuit on the audio interface (1) CCA, described in paragraph 4-7b. The VHF-FM D/A circuit uses analog switches U23 and U24, NAND gate (inverter) U2D, CVSD modem U25, and filter/amplifier U26A. The HF-SSB D/A circuit uses analog switches U16 and U17, buffer (inverter) U20B, CVSD modem U18, and filter/amplifier U19A. In the IC D/A circuit, the IC XMT SOURCE SEL line selects the digitized transmit audio and the 25 kHz clock line to be used by the CVSD modem U9. If the IC XMT SOURCE SEL line is low, analog switch U1 selects the digitized audio and 25 kHz clock from the RSC1 UART. If the IC XMT SOURCE SEL line is high, the digitized audio and 25 kHz clock from the RSC2 UART are selected. The selected clock line to U9 is disabled by analog switch U1B if the IC PTT line is high. The CVSD modem configuration for the IC D/A circuit (U9) is the same as the audio interface (1) D/A modem circuits. The analog output from U9 is sent through a filter/amplifier circuit, containing amplifier U5A.

c. Audio Control UART. The control signals used on the audio interface (1) and audio interface (2) CCAs are sent to the audio interface (2) CCA in serial form. Serial data from the red interface is received at P1-11. This data is in the form of an 8-bit word transmitted at 390 words per second. This serial data is supplied to the serial data input of UART U12, which converts it to eight bits of parallel data. The 390 words per second rate translates to a 50 kHz receive clock frequency. When a word is received, the data available (DA) signal from U12 goes high. The DA signal passes through NOR gate U11C, provided that the D/A reset (DAR #) line is high. (If the DAR # line is low when the DA line goes high, an overrun condition exists.) The inverted DA signal from the NOR gate is input to shift register U10A and is shifted out after four cycles of the 50 kHz clock (80 us). When the shift register output (DAR # signal) goes low, the DA signal to the shift register input is disabled. These events produce an 80 us low pulse on the DAR # line, clearing the data available flip-flop for the next word of data. The UART U12 also transmits serial data to the red interface CCA. The same data rate is used, although only six bits of the eight bits per word are used. The same 50 kHz clock is used both as the transmit clock and receive clock. Transmit bus bits TB0, TB1, and TB2 are used for the parity error (PE), framing error (FE), and overrun error (OE) signals, respectively, from U12. Transmit bus bits TB3, TB4, and TB5 are used for the IC AUDIO PRESENT #, VHF-FM SQUELCH #, and IC TRANSMIT IND signals, respectively. Data presented to the transmit bus is loaded for transmission when the transmit holding register load (THRL #) signal to U12 goes low. The inverted DA signal from the output of NOR gate U11C is used as the THRL # signal. This means that every time a word is received (without overrun) by the UART, a word is transmitted. Serial data output (SDO) from the UART is supplied to amplifier U6A and, from the output of U6A, to P1-43.

d. Audio Control Data Lines. The RB0 through RB3 receive bus lines from UART U12 are supplied to the inputs of 4-bit latches U14A, U14B, U15A, and U15B. The RB4 through RB7 lines from U12 are input to a 4-to-16 line decoder, U13. The S2, S3, S4, and S5 outputs of decoder U13 clock the U15B, U15A, U14B, and U14A latches, respectively. When clocked, the levels of the RB0 through RB3 lines are also supplied to latches on the audio interface (1) CCA through connectors P1-54 (RB0), P1-25 (RB1), P1-58 (RB2), and P1-59 (RB3). The S0 and S1 outputs of decoder U13 (STROBE 1 and STROBE 2 lines) are clock signals to similar latches for the UHF-AM and VHF-AM control lines on the audio interface (1) CCA. Latches U14A and U15A provide the squelch indicator, sources select, data port enable, and PTT signals for

the VHF-FM and HF-SSB audio circuits. Latch U14B provides the IC OFF/ON, IC PTT #, IC SIDETONE/RCV CONT, and IC XMT SOURCE SEL signals. Latch U15B is a spare.

e. VHF-FM Squelch and IC Audio Present Circuits. These circuits generate a digital signal which indicates the presence of audio from the VHF-FM or IC subsystems. Analog audio signals from the VHF-FM AUDIO IN line are detected by diode CR2, which causes the negative input of comparator U6D to go high and the output of U6D to go low. Analog audio signals from the IC AUDIO IN line are detected by diode CR1, which causes the negative input of U6C to go high and the output of U6C to go low. The outputs of U6C and U6D are the IC AUDIO PRESENT # and VHF-FM SQUELCH # lines, respectively.

f. +8.5 V and +17 V Regulators. Shunt divider voltage regulator circuits on the audio interface (2) CCA provide +8.5 VDC and +17 VDC for circuits on the audio interface (1) and audio interface (2) CCAs. Positive 17.5 VDC power is input at P1-60 to a regulator circuit consisting of transistors Q5 through Q7 and associated components. The output of this circuit is filtered by capacitors C27, C45, and C78 and is supplied to the audio interface (1) CCA through P1-26. The +8.5 VDC circuit, consisting of Q2 through Q4 and associated circuitry, is identical, except for resistor values and the addition of more filter capacitors. Positive 9 VDC power is input at P1-22 and +8.5 VDC power is output at P1-24.

4-8. RED INTERFACE CCA. The red interface CCA 1A3 is contained in the SDU and provides a programmable peripheral communications interface between the CPU (which processes parallel data) and serial data sent and received by the RSCs. The red interface handles both audio information and control for the audio information. Refer to figure 4-3 and FO-4. This CCA includes decoder/multiplexer circuitry, amplification circuitry, and shift registers. Also included in this CCA is circuitry for programmable peripheral interfacing, USARTs, Darlington amplifiers, and a pull-up resistor package.

a. Decoder/Multiplexer Circuitry. A Schottky-clamped TTL MSI decoder/multiplexer, U13, is used for data-routing of a very short propagation delay time. It decodes one-of-eight lines Y0 through Y7, dependent on the conditions at the three binary select inputs (SEL A, SEL B, and SEL C) A10 P1-53, A11 P1-8, and A12 P1-9, respectively, and at two of the three enable inputs IO #/M, and WR#/RD#, P1-10 and P1-11. The CPU activates CS # the CCA components in this way. All the inputs of this decoder/multiplexer are fully buffered and are clamped with high-performance Schottky diodes to suppress line ringing. The CPU coordinates the activities of the red interface CCA through U13. The select (P1-8, - 9, and 53) and enable (P1-10, -11, and -12) inputs of U13 are addressed by the CPU to chip select the correct microcircuits (U1, U4, U5, U10, U11, and U12) at the appropriate times.

b. Amplification Circuitry. Microcircuits U6, U7, U8B, U8C, U9B, and U9C are voltage comparator line drivers which use hysteresis to prevent triggering by noise spikes. U8B and U9B control DATA CLOCK VHF-AM and DATA CLOCK UHF-AM (P1-51 and P1-5, respectively). The VHF CLK is input to digital microcircuit U4-12; and the UHF CLK to U5-12. Op-amps U8D and U9D are configured to control the DATA LOAD VHF-AM (P1-52), and DATA LOAD UHF-AM (P1-49) as INTERRUPT 2 (P1-7) and INTERRUPT 3 (P1-4), respectively, to the CPU. These microcircuits invert the input signals. Pull-up resistor package R1 sets reference voltages for microcircuits U8B, C, and D and U9B,

C, and D. Voltage levels of +2.5 VDC can be viewed at test points TP3 and TP4. U8A-7 receives RED PULL-UP VOL on P1-47 and RED VOL REF from P1-2 on pin 6. U9A-2 receives RED PULL-UP VOL on P1-48 and RED VOL REF from P1-3 on pin 6. U14A-11 receives RED PULL-UP VOL from P1-55 and RED REF VOL from P1-54 on pin 10. U14B, C, and D are line drivers for USARTs U10, U11, and U12 and are described under those paragraphs.

c. Shift Register Circuitry. Digital microcircuits U4 and U5 are buffer storage shift registers which serially load bits of information from the VHF and UHF AM radios.

(1) Shift Register U4. U4 handles VHF-AM information, while U5 handles UHF-AM information. DATA CLOCK VHF-AM is applied at U4-12 (CLK), SERIAL DATA VHF-AM is loaded in at U4-18, and DATA LOAD VHF-AM is applied through comparator U8D as INTERRUPT 2 to the CPU. The CPU then chip selects (U4-2) by a low from decoder U13. The SERIAL DATA at U4-18 is then read into the CPU over the data bus. Pins U4-1 and -3 are tied low; U4-9 and -19 are tied high at +5 VDC.

(2) Shift Register U5. U5 handles UHF-AM. DATA CLOCK UHF-AM is applied at U5-12 (CLK), SERIAL DATA VHF-AM is loaded in at U5-18, and DATA LOAD VHF-AM is applied through comparator U9D as INTERRUPT 3 to the CPU. The CPU then chip selects (U5-2) by a low from decoder U13. The SERIAL DATA at U5-18 is then read into the CPU over the data bus. Pins U5-1 and -3 are tied low; U5-9 and -19 are tied high at +5 VDC. Both U4 and U5 send parallel data on the bidirectional data bus.

d. Monitor and Command/Control Circuitry of VHF-AM and UHF-AM. Digital microcircuit U1 is a programmable peripheral interface which is used to continuously monitor the status of the VHF-AM and UHF-AM subsystems. Upon command by the processor, it provides frequency change, synchronized PTT (different from crypto PTT), and data available inputs to those subsystems. Status conditions monitored by the peripheral interface are BITE fault, clear/secure indicate, squelch indicate, and PTT indicate. This device is electrostatic-sensitive.

(1) Status Monitoring Circuitry.

(a) VHF-AM BITE FAULT. The VHF-AM BITE FAULT (P1-42) status signal is set by pull-up resistor package R59 and threshold resistor R3 and is sent to U6A-10. U6A senses the changes and applies it to U1-18. Semiconductor device CR1 is a zener which regulates overvoltage to U6A. Resistors R15 and R16 provide a floating ground voltage level for the noninverting input U6A-11 across pull-up resistor R4. R5 is a feedback hysteresis resistor.

(b) VHF-AM CLEAR/SECURE IND. The VHF-AM CLEAR/SECURE IND (P1-87) status signal is set by pull-up resistor package R59 and threshold resistor R6 and is sent to U6B-8. U6B senses the change and applies it to U1-19. Semiconductor CR2 is a zener which regulates overvoltage to U6B. Resistors R7 and R15 provide a floating ground voltage level for the noninverting input U6B-9 across pull-up resistor R7. R8 is a feedback hysteresis resistor.

(c) VHF-AM SQUELCH IND. The VHF-AM SQUELCH IND (P1-86) status signal is set by pull-up resistor package R59 and threshold resistor R6 and is sent to U6C-6.

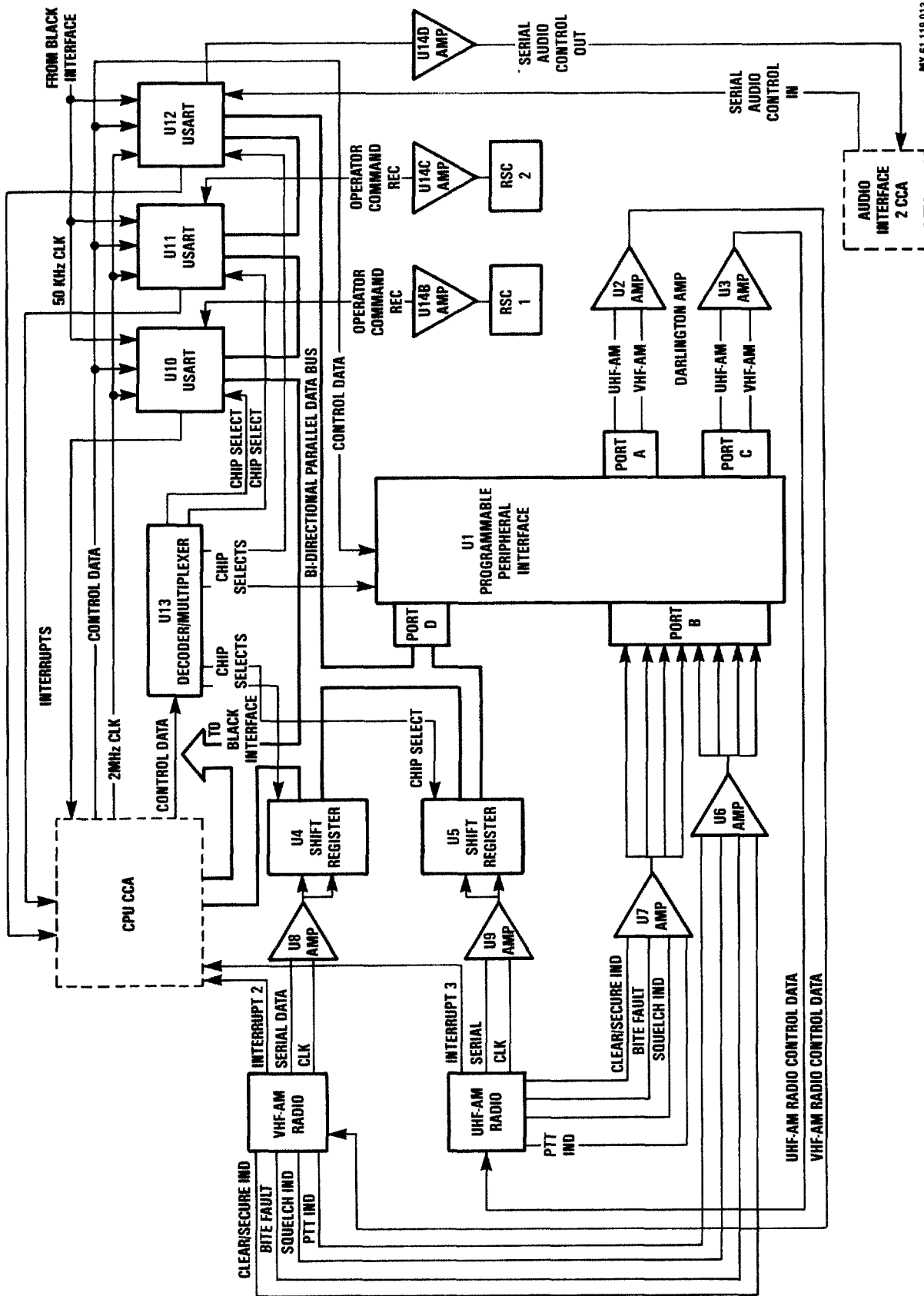

Figure 4-3. SDU Red Interface CCA 1A3 Block Diagram

U6C senses the change and applies it to U1-20. Semiconductor CR3 is a zener which regulates the overvoltage to U6C. Resistors R10 and R15 provide a floating ground voltage level for the noninverting input U6C-7. R10 is a pull-up resistor. R11 is a feedback hysteresis resistor.

(d) VHF-AM PTT IND. The VHF-AM PTT IND (P1-41) status signal is set by pull-up resistor package R59 and threshold resistor R6 and is sent to U6D-4. U6D senses the change and applies it to U1-21. Semiconductor CR4 is a zener which regulates the overvoltage to U6D. Resistors R13 and R15 provide a floating ground voltage level for the noninverting input U6D-5. R14 is a feedback hysteresis resistor. A voltage level of 3.06 VDC can be viewed at TP1. This voltage level is divided by resistors R15 and R16. R13 is a pull-up resistor.

(e) UHF-AM BITE FAULT, CLEAR/SECURE IND and SQUELCH IND. UHF-AM BITE FAULT, CLEAR/SECURE IND and SQUELCH IND signal status monitor circuits operate identically to the VHF-AM circuits described above. Although the reference designators are different, the component values are the same. The status signals are input to U1-22, -23, and -24, respectively. UHF-AM PTT IND signal is routed through circuitry identical to the VHF-AM, but the PTT output of the op-amp U7D-2 is routed through P1-61 as RESET 6.5 to the CPU. A voltage level of 3.06 VDC can be viewed at TP2.

## (2) Command/Control Circuitry.

(a) Mode Selection. The selection of modes of operation of U1 depends upon commands from the CPU. There are three basic modes of operation (figure 4-4) that can be selected by the CPU:

Mode 0 - Basic Input/Output  
 Mode 1 - Strobed Input/Output  
 Mode 2 - Bidirectional Bus

When the reset input goes high, all ports will be set to the input mode. After the reset is removed, U1 can remain in the input mode with no additional initialization required. During the execution of the system program, any of the other modes may be selected using a single output instruction. Ports A and C are output ports, and port B is an input port.

(b) UHF-AM Frequency Control. UHF-AM radio frequency change requests are received in U1 through data bus D0 through D7 and are sent through port A and linear microcircuits (Darlington amplifiers) U2A through U2D to the UHF-AM radio. P1-26, -70, -25, and -69 are utilized. The VHF-AM and UHF-AM subsystems provide their own data load signals (INTERRUPTS 2 and 3) to the processor CPU. The CPU polls each chip constantly, and data already latched into the peripheral interface is available to the processor on request. Pull-up resistor package R2 ensures outputs are high.

(c) VHF-AM Frequency Control. VHF-AM radio frequency change requests are processed in the same manner as those of the UHF-AM described above. Port A outputs PA4 through PA7, Darlington amplifiers U2E through U2G and U3A, and pins P1-21, -24, and -27 and used to route the signals to the VHF-AM radio.

(d) UHF-AM and VHF-AM DATA AVAIL and PTT. DATA AVAIL and PTT are routed to both the UHF-AM and VHF-AM in the same manner as those described above. Port C lower (PC0-PC3) and Darlington amplifiers U3B, C, D, and E route these signals out through P1-66, -22, -67 and -23, respectively. P1-20, -64, -65, and -68, along with Darlington amplifiers U3F and G, are spares.

e. Universal Synchronous/Asynchronous Receiver/Transmitter Circuitry.

Microcircuits U10, U11 and U12 are USARTs designed for data communication with the CPU. Each USART is a three-state, bidirectional, 8-bit buffer used as a peripheral device and is programmed by the CPU to operate using a serial data transmission technique. The USART accepts data characters from the CPU in parallel format and then converts them into a continuous serial data stream for transmission.

Simultaneously, it can receive serial data streams and convert them into parallel data characters for the CPU. The USART will signal the CPU whenever it can accept a new character for transmission or whenever it has received a character for the CPU. The CPU can read the complete status of the USART at any time.

(1) Microcircuit U10. U10 provides operator command data interface for URSC1. The functions of the USART are described below:

(a) Chip Select. U10 is enabled by a command from the CPU through the decoder U13-15 as a low on U10-11.

(b) CPU Command Inputs. The CPU command inputs include RESET, RD #, WR # and C/D #.

(c) TxC # (Transmitter clock). The 50 kHz clock from the black interface is received through P1-39 and is used in the USART to clock the transmitter (U10-9) and receiver (U10-25).

(d) Data Bus Parallel Data Inputs. This 3-state, bidirectional, 8-bit buffer is used to interface the USARTs to the system data bus. Data is transferred or received by the buffer upon execution of input or output instructions of the CPU. Control words, command words, and status information are also transferred through the data bus buffer. The command status, data-in, and data-out registers are separate, 8-bit registers communicating with the system bus through the data bus buffer. The data bus accepts inputs from the system control bus and generates control signals for overall device operation. It contains the control word register and command word register that store the various control formats for the device functional definition.

(e) CPU Interrupt Lines. U10-14 and -15 are INTERRUPT 0 and INTERRUPT 6 lines to the CPU. A high on RX RDY (U10-14) tells the CPU that the receiver is ready with data bit information for the CPU. A high on TX RDY (U10-15) tells the CPU that the transmitter is ready for data bit information from the CPU.

(f) RSC Serial Data. U10 handles data interfacing for RSC1. RSC1 COMMAND REC serial data (P1-85) is applied to RX DATA (U10-3). Serial data out (TXD U10-19) is applied to microcircuit U14B-9, the noninverting pin. A reference voltage of +2 VDC is developed across R53 and applied to U14B-8.

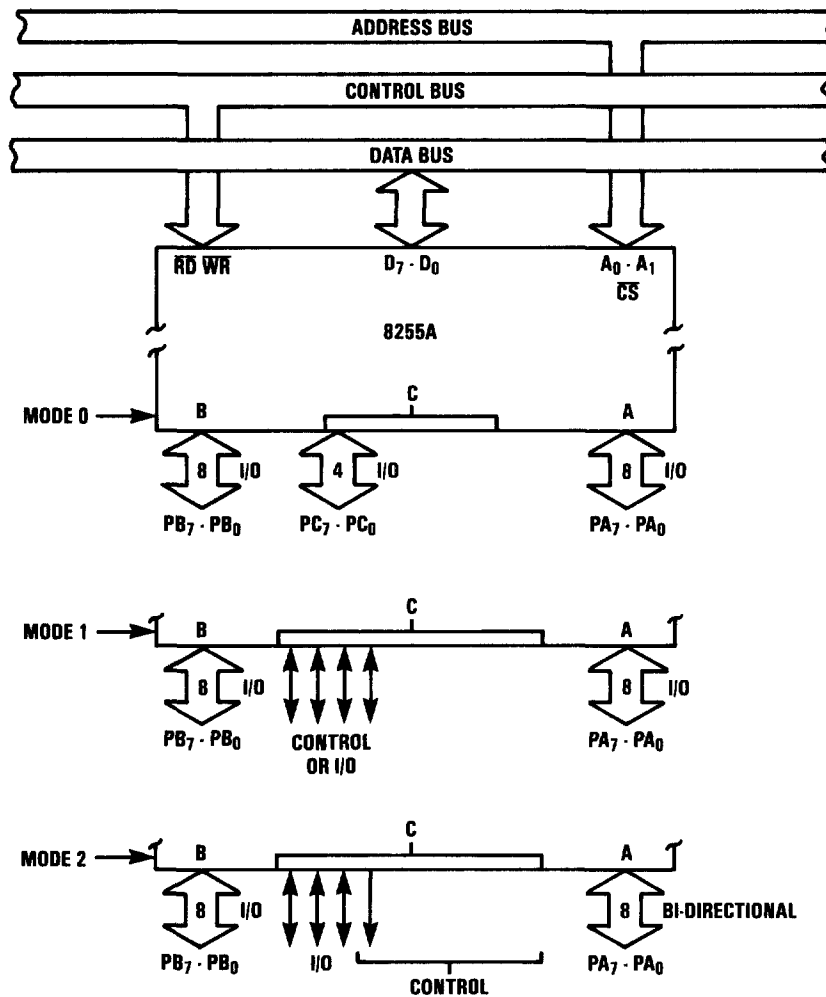

MX-61-119 014

Figure 4-4. Red Interface Basic Mode Definitions and Bus Interface

The output (U14B-14) is sent through P1-56 as RSC 1 OPERATOR COMMAND TRANSMIT. This serial (RSC1 or RSC2) operator command transmit data from the USART provides its associated UART (on CCA A1) with subsystem select data and the appropriate Go-No-Go command depending on subsystem status and Radio System configuration.

(g) Data Set Status. DSR # (data set ready) (U10-22) and CTS # (clear to send) (U10-17) are both tied low to allow U10 to send data whenever required by the CPU. SYNDET/BD (U10-16), RTS # (U10-23), DTR # (U10-24), and TXE (U10-18) are unused and left floating.

(2) Microcircuit U11. Microcircuit U11 provides operator command data interface for RSC2. The functions of this USART are the same as described above with the following exception:

(a) Chip Select. U11 is enabled from decoder/multiplexer U13-14.

(b) CPU Interrupt Lines. U11-14 is the RX RDY INTERRUPT 1 line to the CPU. U11-15 is the TX RDY INTERRUPT 7 line to the CPU.

(c) RSC Serial Data. U11 handles data interfacing for RSC2 COMMAND REC serial Data (P1-38). Serial data out (TXD U11-19) is applied to microcircuit U14C-7. The +2 VDC reference voltage is developed across R54 and applied to U14C-6. The output is sent through P1-58 as URSC2 OPERATOR COMMAND TRANSMIT.

(3) Microcircuit U12. Microcircuit U12 outputs serial audio control data to the UART on audio interface (2) CCA. This serial audio control data is used by the UART for switch matrix control and subsystem decoding. The functions of this USART are the same as described above with the following exceptions:

(a) Chip Select. U12 is enabled from decoder/multiplexer U13-13.

(b) CPU Interrupt Lines. U12-14 is the RX RDY INTERRUPT 5 line to the CPU. U12-15 is the TX RDY INTERRUPT 9 line to the CPU.

(c) Serial Audio Control. U12 handles SERIAL AUDIO CNT IN from the audio interface (2) CCA on P1-81. This is received as RX DATA (U12-3). Serial data out (TXD U12-19) is applied to microcircuit U14D-5. The +2 VDC reference voltage is developed across R55 and applied to U14D-4. The output is sent through P1-57 as SERIAL AUDIO CNT OUT to the UART on audio interface (2) CCA.

f. Input Power Filter Circuit. Capacitors C1 through C14 provide filtering of the +5 VDC input across P1-45 and -90, and GNDs P1-41 and -1. RED PULL-UP VOL of +5 VDC is supplied at P1-15 and developed across resistor R56 for the pull-up voltage circuitry. RED VOL REF of +2 VDC (P1-63) is developed from +5 VDC, divided and filtered across resistors R57 and R58 and capacitor C15.

4-9. BLACK INTERFACE CCA. Black interface CCA 1A4 provides status monitoring and control for the HF-SSB and VHF-FM subsystems. It also provides communications interface for the HF-SSB and clock divider circuits to attain desired frequencies. Black interface circuits include two programmable peripheral interfaces, a 512-bit electrically alterable ROM (EAROM), an octal transceiver, a USART, and various



timing and I/O circuits. The programmable peripheral interfaces and USART are interfaced to the processor via a bidirectional data port. Refer to block diagram figure 4-5 and schematic FO-5.

a. Monitor and Command/Control Circuitry, HF-SSB and VHF-FM. Peripheral interface U3 is used to continuously monitor the status of the HF-SSB and VHF-FM subsystems. Upon command by the processor, it provides preset channel (CH1 - CH10) select data to the VHF-FM subsystem (subsystems employing RT-246, only). This device (U3) is electrostatic-sensitive.

(1) Status Monitoring Circuitry. Status conditions monitored by this peripheral interface are: tune-in-progress (TIP), power amplifier BITE, VHF BITE, KY/KY #, and RT-246 detect. Resistor package R40 provides the pull-up +5 VDC for this input circuitry. Resistor package R39 provides +5 VDC pull-up for inputs to Port B of U3.

(a) TIP. The TIP signal (ground) enters the black interface CCA through P1-72. It pulls down the pull-up voltage of resistor package R40. This low is fed through resistor R13 and applied to microcircuit inverting input U7A-10. Zener diode CR1 regulates the input voltage. The microcircuit U7A is a comparator line driver. Resistor R15 is a feedback resistor which uses hysteresis to prevent triggering by noise spikes. The noninverting side of comparator U7 is held at +2 VDC by voltage divider R11 and R12. TIP is applied to PB3 of U3. A high on this pin indicates that the RT-1444 has been powered up and is self-testing, but not transmitting. When RT-1444 is removed, pull-up voltage resistor package R40 pulls the input to U7A-10 high. This is inverted and appears as a low at U3-PB3. The following circuits operate similarly, except for RT-246 DETECT.

(b) Power Amplifier BITE. The power amplifier BITE signal enters through P1-26. It is fed through resistor R16 and applied to inverting input U7B-8. Zener diode CR2 regulates the input voltage. Resistor R18 is the feedback resistor for U7B. Resistor R17 delivers the +2 VDC from voltage divider R11 and R12 to U7B-9. The POWER AMPL BITE signal is applied to PB2 of U3. This circuit monitors the status of the RT-1209 power amplifier. A high on this pin indicates that the power amplifier is operating correctly.

(c) VHF BITE. The VHF BITE signal enters through P1-71. It is fed through resistor R19 and applied to inverting input U7C-4. Zener diode CR3 regulates the input voltage. Resistor R21 is the feedback resistor for U7C. Resistor R20 delivers the +2 VDC from voltage divider R11 and R12 to U7C-5. The VHF BITE signal is applied to PB1 of U3. This circuit monitors the status of VRC-12 since it is not monitored elsewhere. A high on this pin indicates that the VRC-12 is operating correctly.

(d) KY/KY #. The KY/KY # signal enters through P1-25. It is fed through resistor R22 and applied to inverting input U7D-6. Zener diode CR4 regulates the input voltage. Resistor R24 is the feedback resistor for U7D. Resistor R23 delivers the +2 VDC from voltage divider R11 and R12 to U7D-7. The KY/KY # signal is applied to PBO of U3. This circuit indicates whether or not the KY-57 encryption equipment is installed. A high on this pin indicates the encryption equipment is installed.

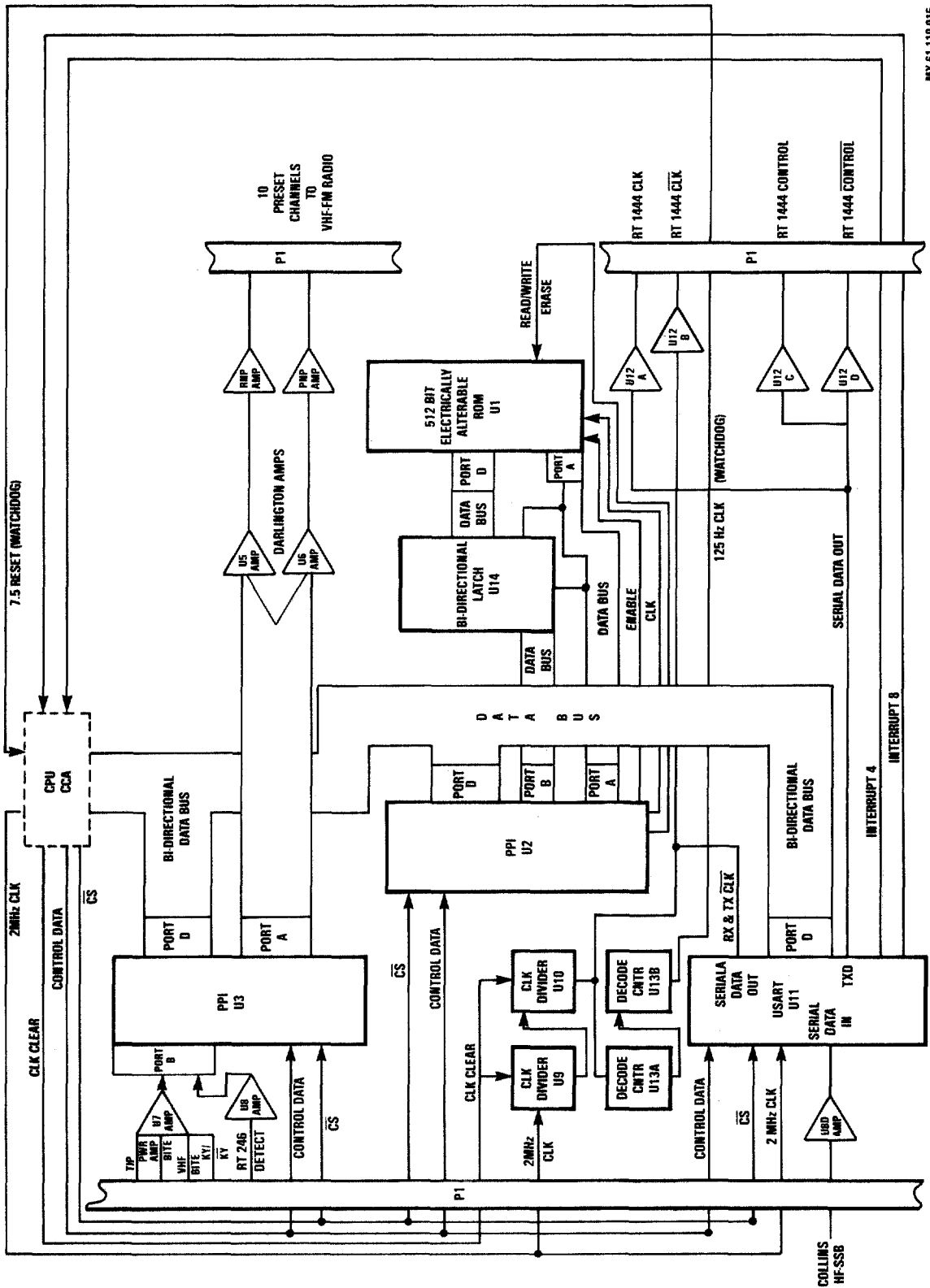

MX-67-119-015

Figure 4-5. SDU Black Interface CCA 1A4 Block Diagram

(e) RT-246 DETECT. The RT-246 DETECT signal (ground removed) from P1-7 enters through P1-3. Pull-up voltage +28 VDC is fed through voltage divider resistors R45 and R48 to noninverting input U8C-5. Inverting input U8C-4 is held at the reference voltage by resistor package R39 and resistor R47. Resistor R47 is the feedback resistor. When RT-246 is installed, a high is applied to U3-PB4.

(f) Test Point 1(TP1). TP1 monitors the +2 VDC applied to the non-inverting inputs of U7. The presence of +2 VDC indicates that status monitoring of TIP, PWR AMP BITE, VHF BITE, and KY/KY # is occurring.

(2) Command/Control Circuitry. The command/control of the HF-SSB and VHF-FM subsystems is accomplished through programmable peripheral interface U3 by the CPU.

(a) Read/Write and Control Logic. These functions manage all of the internal and external transfers of both Data and Control or Status words. It accepts inputs from the CPU address and control buses and, in turn, issues commands to both of the control groups. The control word register can only be written into. No read operation of the control register is allowed.

Control Group A - Port A and Port C lower (C0 and C1) are outputs.

Control Group B - Port B (B0 through B4; B5 through B7 are spares). Control Group B and the high C ports are inputs.

(b) Mode Selection. The selection of modes of operation of U3 depends upon commands from the CPU. There are three basic modes of operation (figure 4-6) that can be selected by the CPU:

Mode 0 - Basic Input/Output  
 Mode 1 - Strobed Input/Output  
 Mode 2 - Bidirectional Bus

(c) VHF-FM Preset Frequency Output Circuitry. Port A and Port C lower (C0 and C1) are used to output the preset frequencies through Darlington pair amplifiers U5A through U6C and PNP drive transistors Q1 through Q10. This amplified output is sent through diodes CR29 through CR38 and connector P1 channels 1 through 10, respectively, to the VHF-FM radio. Resistor package R41 provides +28 VDC pull-up voltage for this circuitry. This voltage is current-limited and applied across resistor R1 through R10, respectively, to the bases of transistors Q1 through Q10. Darlington amplifiers U6D through U6G are not used, and their inputs and outputs through P1 are left floating.

(d) Data Bus. Data Bus provides data bus I/O connecting U3, programmable peripheral interface U2, and communication interface U11 on this CCA. Communication is also provided to the CPU and red interface CCAs through P1-AD0 through -AD7.

b. Command/Control Circuitry of RSC Action Data. The microcircuit U14 is an octal transceiver which consists of two 8-bit parallel I/O ports and is used as a bidirectional data bus between programmable peripheral interface U2 and EAROM U1. Together, these three devices assist the processor in performing command and control functions on action data received from the RSC. These devices, under processor

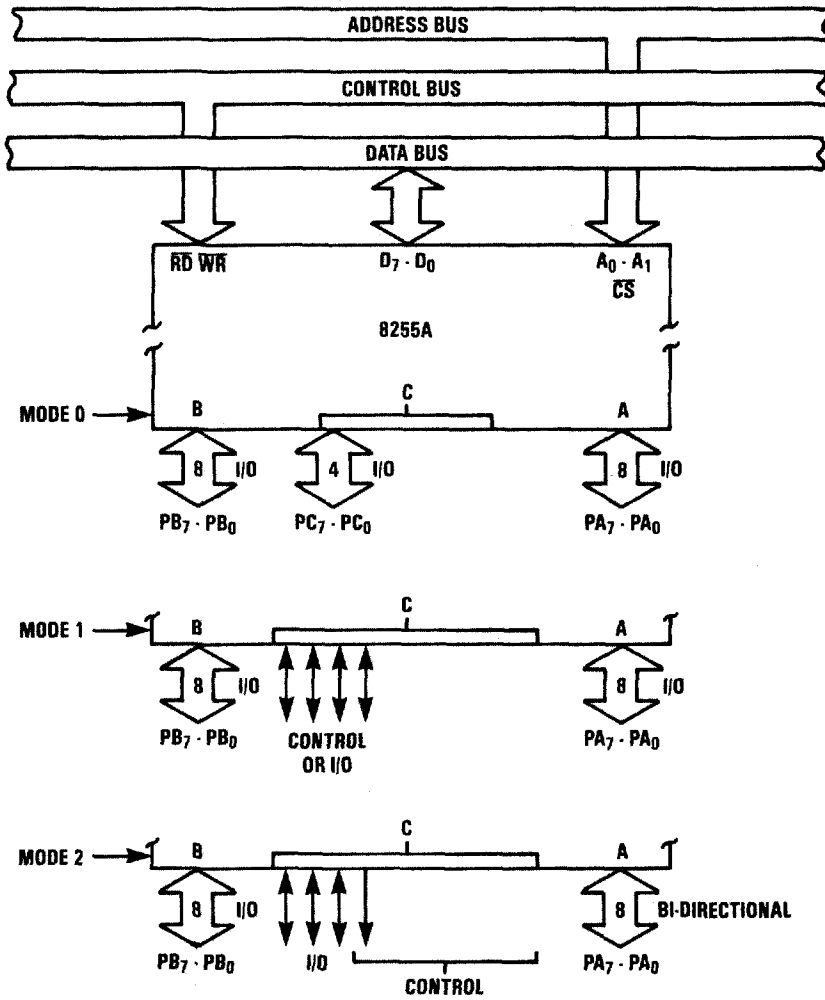

MX-81-119-014

Figure 4-6. Black Interface Basic Mode Definitions and Bus Interface

control, allow action data from the RSC to be permanently stored, changed, or updated, while at the same time supplying the data back to the active RSC for display and operator interface.

(1) Programmable Peripheral Interface Circuitry. This device (U2) is sensitive to electrostatic damage. This digital microcircuit is identical to U3 described above, with the following exceptions:

(a) Read/Write and Control Logic. The read/write and control logic of this digital microcircuit (CS #) is received from the CPU through P1-65.

(b) Port B I/O Circuitry. Port B is a bidirectional bus. The I/O data, which goes through the bidirectional latch to EAROM U1, is sent through Port B (B<sub>0</sub>-B<sub>7</sub>).

(c) Address Circuitry. Port A (A<sub>0</sub>-A<sub>5</sub>) is output. It is used to send the 64 possible addresses to digital microcircuit U1. These commands are CPU-controlled.

(d) EAROM Control Circuitry. Port C lower (C<sub>0</sub>-C<sub>3</sub>) is output. It is used to send EAROM control signals. PC1 sends the ENBL to the EAROM. A high from here, along with CLK from PC0, enables the EAROM.

(2) EAROM Operation. Digital microcircuit U1 provides 512 bits of electrically alterable ROM and contains 64 separate addresses, each of which are able to hold 8 bits of information. U1 receives ENBL (U1-17 and -18 and CLK U1-13) from programmable peripheral interface U2. Mode control of read, write, or erase is input through U1-15 and -16. The 8-bit RSC data is thus handles back and forth through bidirectional latch U14 and programmable peripheral interface U2 to the CPU by the data bus. Once the enter key is depressed on the active RSC, the processor executes the enter command by updating the appropriate subsystem and both RSC1 and RSC2 displays. Digital microcircuit U1 is electrostatic-sensitive.

c. HF-SSB Communication Interface Circuitry. Digital microcircuit U11 is a USART which is used as the communication interface for the HF-SSB subsystem. RT-1444 serial status information is transmitted to the SDU front panel in complementary form for maximum noise immunity and is converted to single-ended form by data I/O circuits. The single-ended data words are fed to the USART which flags (INTERRUPT 4) the processor, indicating that data has been received from the subsystem for output to the processor. Once serviced by the processor, the USART again flags (INTERRUPT 8) the processor, indicating it is available to receive data. The processor inputs control data to the USART via the bidirectional bus. The USART, then under control of the processor, outputs single-ended control data to the data I/O circuits. Timing circuits contained on this assembly generate the RT-1444 clock signal for output by the data I/O circuits. The data I/O circuits convert the single-ended control data and associated clock signals to complementary form from the output to the subsystem.

(1) USART Circuitry. Microcircuit U11 is a USART designed for data communication with the CPU. The USART is a 3-state, bidirectional, 8-bit buffer used as a peripheral device and is programmed by the CPU to operate using a serial data transmission technique. The USART accepts data characters from the CPU in parallel format and then converts them into a continuous serial data stream for transmission.

Simultaneously, it can receive serial data streams and convert them into parallel data characters for the CPU. The USART signals the CPU whenever it can accept a new character for transmission or whenever it has received a character for the CPU. The CPU can read the complete status of the USART at any time. The functions of the USART are described below:

(a) Chip Select. U10 is enabled by a command from the CPU through P1-55 as a low on U10-11.

(b) CPU Command Inputs. The CPU command inputs include RESET, RD#, WR# and C/D#.

(c) RESET (Reset). A high on this input forces the USART into an idle mode. The device will remain at idle until a new set of control words is written into it to program its functional definition. A command reset operation also puts the device into the idle state. This command is routed through P1-18 to U10-21.

(d) RD# (Read). A low on this input informs the USART that the CPU is reading data or status information from it. This command is routed through P1-56 to U10-13.

(e) WR# (Write). A low on this input informs the USART that the CPU is writing data or control words to it. This command is routed through P1-10 to U10-10.

(f) C/D# (Control/Data). This input, in conjunction with the WR# and RD# inputs, informs the USART that the word on the data bus is either a data character, control word, or status information. 1 = CONTROL/STATUS; 0 = DATA. This command is routed through P1-68 to U10-12.

(g) 2 MHz CLK. The 2 MHz clock (P1-17) is input from the CPU through U10-20. The CLK input is used to generate internal device timing. No external inputs or outputs are referenced to CLK, but the frequency of CLK must be greater than 30 times the receiver or transmitter data bit rates.

(h) TXC # and RXCLK # (Transmitter and Receiver Clock). TXC # and RXCLK # are connected to a 12.5 KHz clock and may be pulled high by +28 VDC by pull-up resistor package R39.

(i) Data Bus Parallel Data Inputs. A 3-state, bidirectional, 8-bit buffer is used to interface the USART to the system data bus. Data is transmitted or received by the buffer upon execution of input or output instructions of the CPU. Control words, command words, and status information are also transferred through the data bus buffer. The command status, data-in, and data-out registers are separate 8-bit registers communicating with the system bus through the data bus buffer. Port D accepts inputs from the system control bus and generates control signals for overall device operation. It contains the control word register and command word register that store the various control formats for the device functional definition.

(j) CPU Interrupt Lines. U10-14 and 15 are INTERRUPT 4 and INTERRUPT 8 lines to the CPU. A high on RX RDY (U10-14) tells the CPU that the receiver is ready

with data bit information for the CPU. A high on TX RDY (U10-15) tells the CPU that the transmitter is ready for data bit information from the CPU.

(k) HF-SSB STATUS. U11 handles data interfacing for HF-SSB. RT1209 STATUS and RT1209 STATUS # serial data (P1-2 and 4) is applied through resistors R30 and R33 to the noninverting and inverting inputs of microcircuit U8D. Pull-up voltage of +5 VDC is divided across resistor R29 for R/T1209 STATUS and resistors R31 and R32 for R/T1209 STATUS#. Zeners CR5 and CR6 limit the input voltages to prevent overdriving microcircuit U8D. The output of U8D is applied to RX DATA (U11-3). Serial data out (TXD U11-19) is applied to microcircuit U12C-5, the noninverting pin, and U12D-6, the inverting pin. A reference voltage of +2 VDC is developed across R28 and applied to U12C4 and U12D7. The output of these microcircuits is sent through P1-15 and -59 as RT1209 CONTROL and CONTROL#.

(l) Data Set Status. DSR # (data set ready) (U10-22) and CTS # (clear to send) (U10-17) are both tied low to allow U11 to send data whenever required by the CPU. SYNDET/BD (U11-16), RTS # (U11-23), DTR # (U11-24), and TXE (U11-18) are unused and left floating.

(2) Clock Divider Circuitry. The clock divider circuitry consists of microcircuits U9, U10, and U13 A and B. Also included are microcircuits U12A and B and test point TP2. This circuitry provides the needed frequencies for the R/T 1209 CLOCK, the CPU 50 KHZ CLOCK, and the CPU 125 KHZ CLOCK. Microcircuits U9 and U10 are high-speed monolithic counters consisting of four DC coupled, master-slave flip-flops which are internally interconnected to provide divide-by-five and divide-by-two (U9) and divide-by-two (four times) (U10). During the count operation, transfer of information to the outputs occurs on the negative-going edge of the clock pulse. The CLOCK CLEAR (P1-53) is not used and is left floating. The A, B, C, D, and count/load inputs of U9 and U10 are tied high to +5 VDC clock pull-up. The divide-by-two and divide-by-five (for a divide-by-ten) count is achieved in U9 by applying 2 MHZ CLOCK (P1-17) from the CPU to the clock-2 input (U9-6), while the divide-by-five output (U9-12) is externally connected to the clock-1 input (U9-8). The divide-by-two output (200 KHz) at U9-5 is sent to CLK +1 U10-8. A divide-by-two count, four times, in U10 is achieved by the output U10-5 (100 kHz) being applied to CLK input (U10-6), divided-by-two (50 kHz and 25 kHz) three more times, output on U10-12, and applied as 12.5 KHZ CLOCK to U13A-1. This input clocks the first of two decade dividers in which the enable U13A-2 is held high by +5 VDC. The output from U13A-6 is sent to U13B-9 input as clock for the second decade divider. U13B-10 enable is held high by +5 VDC. The output (U13B-14) is sent through P1-14 as 125 HZ CLOCK to the CPU. U13 is electrostatic-sensitive.

(3) Serial Data Output Circuitry. The serial data output circuitry consists of microcircuits U12A through D and test point TP2. The 12.5 KHZ CLOCK output of U10-12 is applied to the noninverting and inverting inputs U12A and B, respectively, and RXCLK# and TXC# on U11. It is also applied to P1-62, but is unused and left floating. Microcircuit U12A, in conjunction with +5 VDC applied at the inverting input U12A-8, outputs R/T 1209 CLOCK (P1-16). The +5 VDC is also applied to the noninverting pin U12B-11. This microcircuit outputs R/T 1209 CLOCK# through P1-60. The CPU and red interface CCAs receive 50 MHZ CLOCK from U10-9 through P1-58. The 25 KHZ CLOCK and 100 KHZ CLOCK from U10-2 and U10-5, respectively, are applied to

P1-57 and -13, and are unused and left floating. The +5 VDC, used as inputs for microcircuits U12A-D, may be monitored at TP2.

d. Power Supply Circuitry. Negative 28 VDC voltage is applied to the black interface through P1-19. Positive 5 VDC voltage is applied through P1-45 and -90. GND is provided through P1-1 and -46. Capacitors C1 through C15 filter the input DC voltages.

e. Spare Circuitry. Unused or spare circuitry not covered above includes microcircuit U8A, to which is applied BLACK PULL-UP VOL (P1-49) and BLACK VOL REF (P1-47). A SPARE INTERRUPT REQUEST IN (P1-6) circuit includes +5 VDC voltage divider resistors R43 and R34 and voltage regulator zener diode CR7. These input the inverting pin 6 of U8B. The noninverting pin U8B-7 is fed by +5 VDC voltage divider circuit R35, R36, and R37. This power is also fed to BLACK VOL REF (P1-50) which is unused and left floating. R38 is the feedback resistor in the closed-loop operating arrangement of U8B. Plus 5 VDC pull-up voltage is developed across R42 at the U8B output. This SPARE INTERRUPT REQUEST OUT signal (P1-5) is unused and left floating. Plus 5 VDC from resistor package R39 is also applied as BLACK PULL-UP VOL (P1-63). This is jumpered back into the black interface through P1-49 for unused microcircuit U8A.

4-10. CPU CCA. CPU CCA A5 provides the means to control all functions of the Radio System. The major functions controlled are: monitor of system status, audio routing, command and control, operator conflict resolution, communication security scenario, bit error rate compensation, and multiplexer control. These functions are controlled by the microprocessor resident on this CCA. CPU circuits include an 8-bit microprocessor (processor), two programmable interrupt controllers, three 3-to-8 line decoders, four 4096 x 8-bit EPROMs, two 1024 x 4-bit RAMs, a 4 MHz oscillator, an octal buffer, and various gating and I/O circuits. External timing for the processor is provided by the 4 MHz oscillator which supplies an input frequency twice the internal operating frequency of the processor. The processor has internal clock generation and supplies a 2 MHz clock signal to the red and black interface CCAs for system control. The processor has an 8-bit unidirectional address bus and a bidirectional 8-bit data/address bus. The 8-bit (octal) buffer is used to provide a high-speed, high-current interface connecting the processor 8-bit address bus, select lines of the three decoders, and address select lines of the EPROMs. The decoders are used to provide chip enable signals to the RAMs, EPROMs, and interrupt controllers on this assembly and to the peripheral interfaces and UART on black interface CCA A4. Two programmable interrupt controllers are used to process subsystem interrupt flags from the red and black interface assemblies and to resolve interrupt priorities using programmable algorithms controlled by the processor. Once interrupt priorities are established, the processor instructs the interrupt controller to place its preprogrammed interrupt vector address of the selected interrupt on the data bus. The processor then communicates with the selected devices via the bidirectional data bus. All data received from the selected device is verified by the processor against data stored in memory (EPROMs and RAM). The EPROMs store preprogrammed data which includes all allowable operating scenarios and system configurations, command and control instruction formats, and data necessary to provide RSC to SDU bit error rate (BER) compensation. The RAMs provide storage of active or pending data when the Radio System is in use. This data includes active operating configurations of the system, subsystem, and RSCs. An octal latch/register



is interfaced to the data/address bus of the processor and is used to latch address data from the processor to the enabled EPROM or RAM.

a. Functional Operation. The microprocessor controls the functions of the Radio System through interface circuits in the SDU. All control, monitor, and command functions pass through the microprocessor. All audio routing, multiplexing, and demultiplexing is accomplished through hardwired discrete logic operations under microprocessor control. The SDU, controlled by the microprocessor, accomplishes its task via two operating modes.

(1) SDU Initialization Mode. When power is enabled to the SDU circuits, the microprocessor enters an initialization mode. During this mode, all transmit key lines are disabled, all delays are established, and a valid control word is sent to each subsystem (radio set). This control word prevents any problems that may result from a false control word being applied to a radio subsystem. Upon completion of the initialization functions, the SDU transfers to the run mode (run state).

(2) SDU Run State. The SDU run state consists of a continuous series of functions that are subsets of the run state. The SDU recognizes the following subsets of the run state:

(a) Monitor Status. During monitor status the microprocessor collects data concerning the electrical and physical configuration/status of the total Radio System. Monitor status contains subset functions of: Built-in Test Equipment (BITE) status, clear/secure status of system, receiver status, and system configuration.

(b) RSC Status/Data. The RSC supplies operational action data to the SDU via the RSC status/data subset. This data is stored and executed by the microprocessor. RSC status/data contains subset functions of bit error rate (BER), compensation replies, and radio select/control functions which consist of the following subsets: key lines, transmit audio, frequency/channel commands, and mode information.

(c) Link Maintenance and COMSEC Scenario. This run subset establishes the real-time control of the total Radio System. It controls operators and equipments to eliminate possible compromising of the crypto devices or secure information (Radio System AN/GRC-206(V)1) during transmission by the Radio System. The scenario subset consists of the following: internal status, timing, user conflict resolution with subsets of system conflicts, and operator conflicts.

(d) SDU Data to the RSC. This subset of the run state supplies all system status/data to the RSC for display/interface with the operator. This function consists of the following subsets: entered commands, system status, and operating frequencies.

(e) Subsystem Control Data. This subset includes all data supplied to the Radio System subsystems. This function consists of: valid frequency control data and transmit key control.

(f) Signal Routing and Control. This subset consists of all internal SDU routing scenarios. This function consists of: transmit audio, receive audio, intercom audio, multiplex data link control, and command and control execution.

b. Microprocessor Functional Pin Description. The following paragraphs describe the function of each pin of microprocessor U5. Refer to schematic diagram FO-6.

(1) A<sub>8</sub> through A<sub>15</sub> (Address Bus), Pins 21 to 28. These are the most significant 8 bits of EPROM and RAM memory address. A<sub>10</sub> through A<sub>15</sub> are used as I/O address lines. These are 3-state outputs and are held in the high impedance state during hold and halt modes and during RESET. These lines are output through 8-bit buffer U7.

(2) AD0 through AD7 (Multiplexed Address/Data Bus), Pins 12 to 19. During the first clock cycle of each machine cycle, the lines output the lower 8 bits of memory address to 8-bit latch U6. During the second and third clock cycles, AD0 through AD7 lines become data lines.

(3) ALE (Address Latch Enable), Pin 30. This output goes high during the first clock cycle of each machine cycle. This signal is provided to P1-15 (ALE), looped back through P1-19 (ENABLE G), and supplied to the output enable of address latch U6. The falling edge of ALE is set to guarantee setup and hold times for the address information.

(4) IO/M#, S0, and S1 (Machine Cycle Status). These outputs indicate the status of the current machine cycle. Refer to table 4-1. The IO/M#, S0, and S1 signals become valid at the beginning of a machine cycle and remain stable throughout the cycle. The S0 and S1 signals are not used in this system. The IO/M# signal is used to select either the memory or the I/O devices as inputs to the data lines.

Table 4-1. Machine Cycle Status

| <u>IO/M#</u> | <u>S<sub>1</sub></u> | <u>S<sub>0</sub></u> | <u>Status</u>         |
|--------------|----------------------|----------------------|-----------------------|
| 0            | 0                    | 1                    | Memory write          |
| 0            | 1                    | 0                    | Memory read           |
| 1            | 0                    | 1                    | I/O write             |
| 1            | 1                    | 0                    | I/O read              |
| 0            | 1                    | 1                    | Opcode fetch          |
| 1            | 1                    | 1                    | Interrupt acknowledge |
| .            | 0                    | 0                    | Halt                  |
| .            | X                    | X                    | Hold                  |
| .            | X                    | X                    | Reset                 |

. - 3-state (high impedance)  
X - unspecified

(5) RD# (Read Control), Pin 32. A low at this output indicates that the selected memory or I/O device is to be read and that the data bus is available for the data transfer. This is a 3-state output and is in the high impedance state during hold and halt modes and during reset.

(6) WR# (Write Control), Pin 31. A low level on the WR# output indicates the data bus is to be written into the selected memory or I/O location. Data is set up at the trailing edge of WR#. This is a 3-state output and is in the high impedance state during hold and halt modes and during reset.

(7) READY, Pin 35. This input is pulled high, enabling the read and write cycles to complete without interruption.

(8) HOLD, Pin 39. This input is used by another master requesting the use of the address and data buses. This input is not used in this system and is held low by the output of inverter U22D, whose input is pulled high.

(9) HLDA (Hold Acknowledge), Pin 38. This output indicates that the microprocessor CPU has received a HOLD request. Not used in this system.

(10) INTR (Interrupt Request), Pin 10. This input is used as a general-purpose interrupt. Interrupt signals from the master programmable interrupt controller (U10) are looped from the INT BRK 2 line (P1-63) to the INTERRUPT BRK 1 line (P1-21) to the INTR input of microprocessor U5. The INTR input is sampled only during the next to the last clock cycle of an instruction and during the hold and halt states. If it is active, the program counter (PC) will be inhibited from incrementing and an INTA# will be issued. During this cycle, a RESTART or CALL instruction can be inserted to jump to the interrupt service routine. The INTR is enabled and disabled by software. It is disabled by reset and immediately after an interrupt is accepted. See table 4-2 for interrupt priority, restart address, and triggering.

(11) INTA# (Interrupt Acknowledge), Pin 11. This output is used instead of (and has the same timing as) RD# during the instruction cycle after an INTR has been accepted. It is used to activate programmable interrupt controllers U10 and U11. The INTA# signal is looped from the INTERRUPT BRK 1 line (P1-22) to the INTERRUPT BRK 2 line (P1-3) to U10 and U11.

(12) RESET 5.5, RESET 6.5, and RESET 7.5 (Restart Interrupts), Pins 9, 8, and 7. These inputs have the same timing as INTR, except that they cause an internal RESTART to be automatically inserted. The priority of these interrupts is shown in table 4-2. These interrupts have a higher priority than INTR. In addition, they may be individually masked out using the SIM software instruction. The RESET 7.5 line (from P1-56) is the system watchdog timer signal, a 125 Hz clock, from the black interface CCA. The RESET 7.5 line is inverted by U22A. The RESET 6.5 line (from P1-57) is the PTT indicator (PTT IND) line from the red interface CCA, which signals the microprocessor when a PTT has been received from one of the RSCs. The RESET 5.5 is not used in this system and is held low by inverter U22C, whose input is pulled high.

Table 4-2. Interrupt Priority, Restart Address, and Sensitivity

| Name    | Priority | Address branched to (1)<br>when interrupt occurs | Type trigger                                 |
|---------|----------|--|--|
| TRAP    | 1        | 24H  | Rising edge AND high level<br>until sampled. |
| RST 7.5 | 2        | 3CH  | Rising edge (latched).                       |
| RST 6.5 | 3        | 34H  | High level until sampled.                    |
| RST 5.5 | 4        | 2CH  | High level until sampled.                    |
| INTR    | 5        | See Note (2).                                    | High level until sampled.                    |

## NOTES:

(1) The processor pushes the PC on the stack before branching to the indicated address.

(2) The address branched to depends on the instruction provided to the CPU when the interrupt is acknowledged.

(13) TRAP, Pin 6. Trap interrupt is a nonmaskable interrupt, unaffected by any mask or interrupt enable. This input is not used in this system and is grounded.

(14) RESET IN #, Pin 36. A low at this input sets the program counter to zero and resets the interrupt enable and HLDA flip-flops. The data and address buses and the control lines are in the high impedance state during RESET. Because of the asynchronous nature of RESET, the processor's internal flags and registers may be altered by RESET with unpredictable results. RESET IN# is a Schmitt-triggered input, which is connected to the soft-start (pop) circuit for power-on RESET delay. The microprocessor CPU is held in the reset condition as long as RESET IN # is applied.

(15) RESET OUT, Pin 3. This output, when high, indicates that the microprocessor CPU is being reset. The signal is synchronized with the processor clock and lasts an integral number of clock periods. The RESET OUT signal is supplied to the RESET lines on the red and black interface CCAs, as a system reset, through P1-20.

(16)  $X_1$  and  $X_2$  (Clock Inputs), Pins 1 and 2. These inputs are connected to the 4 MHz oscillator circuit, which provides the external clock for the microprocessor. The  $X_2$  input receives the OSC line signal, and  $X_1$  receives the inverted OSC line signal from inverter U23B. The input frequency is divided by 2 to give the processor's internal operating frequency.

(17) CLK (OUT) (Clock Output), Pin 37. This clock output is used as a system clock (2 MHz CLOCK line) and is supplied to the red and black interfaces through P1-28. The frequency of CLK (OUT) is half the  $X_1$ ,  $X_2$  input frequency.

(18) SID (Serial Input Data Line), Pin 5. Not used in this system. This input is pulled high.

(19) SOD (Serial Output Data Line), Pin 4. Not used in this system.

c. POP Circuit. This circuit provides a low pulse to the RESET IN # input of microprocessor U5 when the +28 VDC system power comes up. This provides a "soft start" for the microprocessor. The POP circuit consists of comparator U12C, inverter U22E, and associated components. When the +5 VDC power comes up, the input of U22E is pulled high by R12. This causes the output to go low, resetting the microprocessor. The negative input to U12C is pulled to +5 VDC by R11. When the +28 VDC power comes up, the positive input to U12C is approximately +4.5 VDC. This causes the output of U12C (which is the input of U22E) to go low and the output of U22E (the RESET IN # input) to go high. When the RESET IN # line returns to a high state, the microprocessor leaves the reset state. A low on the POP# line from P1-78 can also reset the microprocessor; however, the POP # line is not used in this system.

d. 4 MHz Oscillator Circuit. The clock for microprocessor U5 is provided by oscillator U25. A selection circuit composed of U24A, U24B, U24C, and U23A selects between the output of U25 and the EXT CLOCK OSC line. This selection circuit is not used in this system. The output of the selection circuit (U24C, pin 3) is supplied to the X<sub>2</sub> clock input of U5. The same signal, inverted by U23B, is supplied to the X<sub>1</sub> input of U5.

e. EPR0M Memory. Four 4096 x 8-bit EPROMs, U1 through U4, are able to output to the data bus lines AD0 through AD7. To output data to the bus, the OE # (pin 20) and CE # (pin 18) of the select EPROM must both be low. The OE # inputs of all four EPROMs are connected to the RD # line from P1-26. This line is the microprocessor's RD# output, which is looped from P1-6 to P1-26. The CE # input lines from U1 through U4 are enabled by the Y0 through Y3 outputs of decoder U8. For any of the EPROMs to be enabled, U8 must be enabled by a low on the IO/M# line (U8-4), a low on the RD # line (U8-5), and a high on the inverted A15 line (U8-6). When all three of these enable conditions are met, the EPROM to be read is selected by address lines A12, A13, and A14, which are the select inputs to the decoder U8. The A0 through A7 (from address latch U6) and A8 through A11 (from buffer U7) address inputs to the EPROMs then determine which 8 bits will be output to the data bus.

f. RAM Memory. Circuitry is provided on the CPU CCA for eight 1024 x 4-bit RAMs, although fewer may be used. The RAMs are enabled in pairs: U14 and U15, U16 and U17, U18 and U19, U20 and U21. The even-numbered RAM (U14, U16, U18 or U20) of the pair accesses the AD0 through AD3 I/O lines. The odd-numbered RAM (U15, U17, U19, or U21) accesses the AD4 through AD7 data bus lines. The RAM pairs are enabled by the Y0 through Y8 outputs of decoder U13 (Y4 through Y7 are spares). The select lines to U13, which choose the RAM pair, are address lines A10, A11, and A12. Decoder U13 is enabled only when the WR #/RD # line (U13-5) is low, the IO/M # line is low, and the A15 line (U13-6) is high. Address lines A0 through A9 determine which 4-bit word will be accessed from each of the pair of RAMs. The A0 through A9 address lines are used to address the RAMs. Write enable signals to the RAMs (asserted when low) come from the WR # output of U5. When a RAM pair is enabled by U13 and its WRITE ENBL input is low, the data on the AD0 through AD7 lines is stored by that pair of RAMs.

If the WRITE ENBL line is high, the selected pair of RAMs outputs the data stored in the addressed location to the ADO through AD7 lines.

g. I/O Decoder. Decoder U9 is a 3-to-8 line decoder used to enable the various I/O devices which use the ADO through AD7 data bus lines. The device to be enabled is selected by the A10, A11, and A12 address lines, which are the SEL A, SEL B, and SEL C inputs to U9, respectively. Output from U9 is enabled only when the IO #/M line (to U9-4) is low, the WR #/RD # line (to U9-5) is low, and A13 (to U9-6) is high. The IO#/M line is the microprocessors IO/M# line inverted by U22F. The WR#/RD# line is the product of the microprocessors RD# and WR# lines, ANDed by U24D (a NAND gate) and U22E (an inverter). The WR#/RD# line is low when either the RD# or WR# line is low. The Y0 and Y1 outputs of U9 enable the programmable interrupt controllers U11 and U10, respectively. The Y2 through Y7 outputs of U9 are the I/O 28, I/O 2C, I/O 30, I/O 34, I/O 38, and I/O 3C enable lines, which are provided to connectors P1-37 through P1-41 and P1-43. The I/O 28, I/O 2C, and I/O 30 lines are used to enable I/O devices on the black interface CCA. The I/O 34, I/O 38, and I/O 3C lines are spares.

h. Programmable Interrupt Controllers. Programmable interrupt controllers (PICs) U10 and U11 function as an overall manager of the interrupt driven CPU system. When one or more I/O device on the red or black interface wants to communicate with the microprocessor, the following procedure occurs (refer to block diagram figure 4-7):

(1) One or more of the interrupt request lines (IRO through IR7) go high, setting a corresponding bit in the PIC interrupt request register (IRR).

(2) The PIC evaluates these requests and sends an INT to the microprocessor, if appropriate.

(3) The microprocessor acknowledges the INT with a low pulse on the INTA # line.

(4) Upon receiving an INTA # signal, the highest priority in the service register (ISR) bit of the PIC is set, and the corresponding IRR bit is reset. The PIC also releases a CALL instruction code (11001101) on the data bus through its D7-00 pins.

(5) This CALL instruction initiates two more INTA# pulses to be sent to the PIC from the microprocessor.

(6) These two INTA # pulses allow the PIC to release its preprogrammed address onto the data bus. The lower 8-bit address is released at the first INTA# pulse, and the higher 8-bit address is released at the second INTA # pulse.

(7) This completes the 3-byte CALL instruction released by the PIC. Otherwise, the ISR bit remains set until the appropriate EOI (end of interrupt) command is issued at the end of the interrupt sequence.

The two PICs are cascaded in a master/slave configuration with U11 as the slave and U10 as the master. The SP/EN # pin (pin 16) of U10 is pulled high; that of U11 is grounded. The cascade lines (CAS0, CAS1, and CAS2) of U11 are supplied to the

respective cascade lines of U10. The INT line from U11 (SLAVE INTERRUPT, P1-69) is looped back to the IR7 input of U10 through P1-48. The INT line from U10 (INT BRK 2) is looped from P1-63 to P1-21 (INTERRUPT BRK 1), which is the INTR line of the microprocessor. The A0, WR #, and RD # lines of U10 and U11 are connected to the A0, WR #, and RD # lines of the microprocessor to read and write the commands into the PIC command registers, as well as reading the various status registers of the PICs. The CS # line to U10 and U11 are the Y1 and Y0 lines of the I/O decoder U9. The interrupt request lines IR0 through IR3, IR5, and IR6 to U10 come from the red interface CCA; IR4 comes from the black interface CCA; and IR7 is the INT line from U11. The IR0 and IR2 lines to U11 come from the red interface CCA. IR1 comes from the black interface CCA, and IR3 through IR7 are spares.

4-11. SDU POWER SUPPLY SUBASSEMBLY. The power supply subassembly is shown in block diagram form in figure 4-8. Positive 28 VDC power from the power distribution unit (PDU) is filtered by L1 and C1 (R46 discharges C1) and is supplied to the +5 V switcher U1 and the +17.5 V switcher U4. Pulse-width modulators U2 and U3, which drive the switchers, are supplied with input voltage through a regulator circuit. Power input to the 9 V and 12 V regulator circuits is obtained from the +17.5 V output. The following paragraphs describe the operation of the circuits in the power supply subassembly. See figure FO-7 for the SDU power supply subassembly schematic diagram.

a. Input Regulator Circuit. Input voltage to pulse-width modulators U2 and U3 is regulated by an input regulator circuit consisting of Q2, Q3, Q4, R1 through R7, and VR1. Transistor Q7; capacitors C28, C29, and C30; resistor R47; and diode CR8 form a momentary interrupt circuit. A momentary interrupt of the +28 VDC input to the power supply removes power to U2 and U3 for approximately 300 ms.

b. Pulse-Width Modulator Circuits. The circuitry of U2 and U3 is basically the same, except for some resistor values. This paragraph applies to both circuits. U2 and U3 are synchronized in a master/slave relationship by tying the oscillator outputs (pin 3) together. In this configuration, the frequency of U3 makes it the master and U2 the slave. The oscillator frequency is set by the value of the resistor at  $R_T$  (pin 6) and the capacitor at  $C_T$  (pin 7). Voltage error sensing is done at the INVERT (pin 1) and NON-INVERT (pin 2) comparator inputs. The NON-INVERT input is clamped at +2.5 VDC between the +5 VDC V REF output (pin 16) and ground by two 4990 ohm resistors. The INVERT input is clamped at approximately +2.5 VDC (depending on the regulator's output) between the +5 VDC (or +17 VDC) output and ground by resistors. The value of resistor R18 (for U3) or R10 (for U2) shall be determined at the time U2 or U3 is installed. The +5 VDC from V REF is also used in the compensation circuit. The compensation voltage is input to U2 and U3 at pin 9. The CL sensing and the shutdown (SHT DN) inputs (pins 4, 5, and 10) are not used. The collector outputs  $C_A$  (pin 12) and  $C_B$  (pin 13) are paralleled, and the output signal is supplied to the switches through a 10 V zener (VR2 for U3, VR3 for U2) and a resistor (R15 for U3, R23 for U2). This zener diode and resistor protect U2 and U3 from overvoltage damage through U1 and U4.

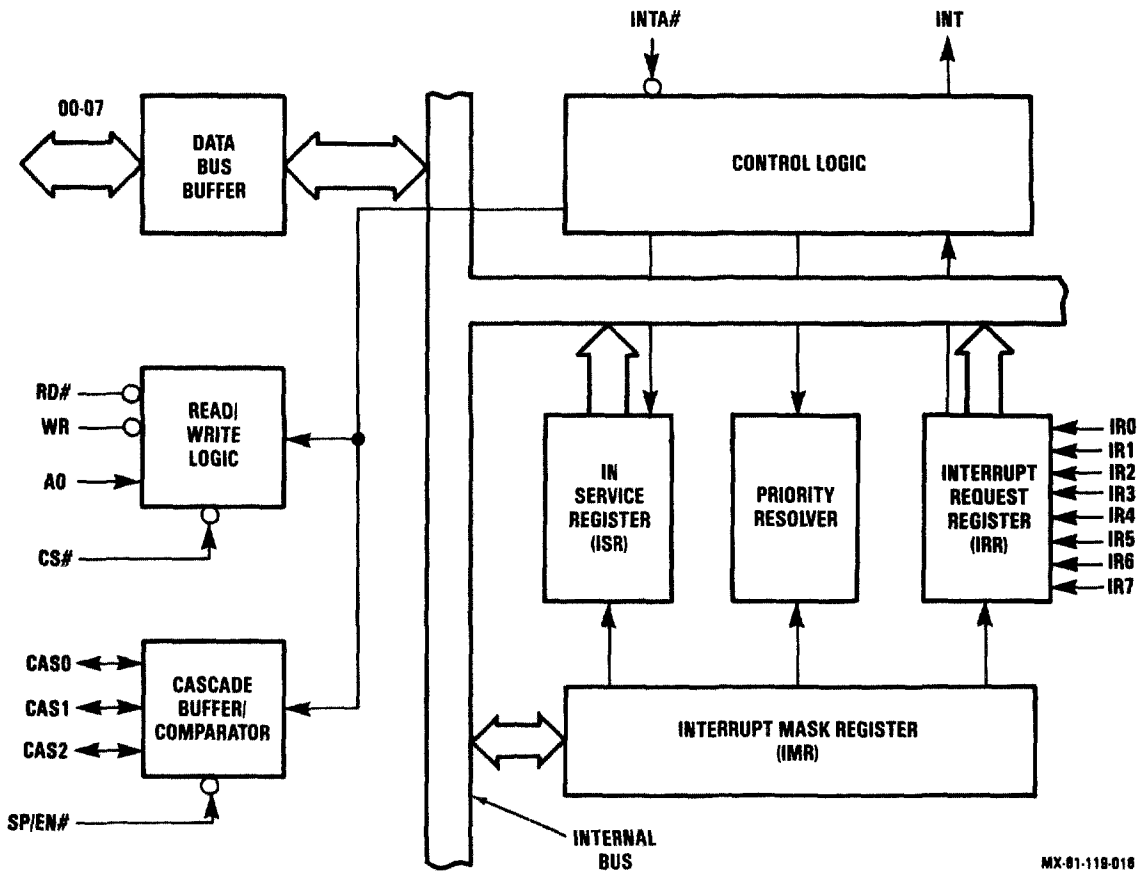

MX-01-118-016

Figure 4-7. PIC Block Diagram



c. Switching Circuits. The +5 V and +17.5 V switching circuits are basically the same. This paragraph will describe the +5 V circuit, with the corresponding components of the +17.5 V circuit in parentheses. The switching regulator U1 (U4) receives +28 VDC at its POS INPUT, pin 4. Both input and output ground are at COMMON, pin 2. The drive signal from U3 (U2) is supplied to pin 3 of the switcher. The positive output from pin 1 is sent to a dual section reactor, L3. The secondary of L3 is used to obtain -29 VDC through rectifier CR3 and R25; output, across R36 and C10, is at P1-7. The +5 VDC is output across C11 and C24 at P1-8 and -23. The +17.5 VDC is output across C13 and C25 at P1-6 and -21. (The output of U4 is sent to an ordinary reactor, L2.) After the reactor, the output is supplied to a current-limiting circuit consisting of Q1, R26, R27, R38, R43, and C23 (Q5, R28, R29, R37, and R45). (Resistor R44, capacitor C22, and SCR Q6 are common to both circuits.) When Q1 (Q5) turns on, Q6 is triggered, removing power to U2 and U3. Capacitors C11 and C24 (C13 and C25) provide further filtering. Overvoltage protection for the output is provided by zener diode VR4 (VR5).

d. +9 V and 12 V Regulator Circuits. The 12 V regulator U6 and the 9 V regulator U5 both use identical circuits, except for some resistor values. Both circuits use regulated and filtered +17.5 VDC from the +17.5 V regulator circuit. This voltage is supplied to the V IN (pin 2) input. Voltage error sensing (to ADJ, pin 1) for U6 is by the circuit consisting of R33, R34, and R35. For U5, the circuit consists of R30, R31, and R32. The values of resistors R35 (U6) and R32 (U5) are determined when U5 or U6 are installed. To provide the correct output voltage. The +12 VDC output from U6 is across capacitors C19 and C27 and is supplied to P1-1. The +9 VDC output from U5 is across C16 and C26 and is supplied to P1-2. Regulators U5 and U6 are protected from reverse voltages by diodes CR4 (U5) and CR6 (U6) across their V IN and V OUT connections and across C19 and C27. Diode CR7 protects against a shorted C18, while CR4 protects against C16 or C26 shorting. CR5 protects against a shorted C15.

4-12. FIBER OPTIC MODULE ASSEMBLY. Fiber optic modules 1A8 and 1A9 or 5A4 and 6A4 are identical; therefore, only one description is necessary. The F/O module consists of F/O transmitter CCA A1, F/O receiver CCA A2, a F/O bulkhead connector, an interface connector, and the F/O module cover. The F/O module provides digital-to-optic and optic-to-digital conversion of communication signals (both audio and control) between the SDU and RSC. The F/O module is capable of full-duplex operation via independent receive and transmit circuits and a two-channel F/O line (F/O cable). The F/O module receiver/transmitter (driver) circuits operate at a data rate of 200 kbps. Supply voltage required for these circuits is +8 to +12 VDC. Maximum supply current required for transmit and receive operations is 150 mA and 70 mA, respectively. I/O signals between the F/O bulkhead connector and the receiver/driver circuits are optically coupled via F/O pigtailed. I/O data between the F/O module and SDU audio interface (1) CCA is CMOS compatible and is routed through the F/O module interface connector.

a. F/O Transmitter CCA A1. Refer to figure FO-8. Fiber optic transmitter CCA A1 receives a transmit signal through connector J1, pin 9 from the SDU audio interface (1) CCA. This voltage is coupled through resistor R7 to the base of the NPN transistor Q2. Positive voltages forward bias the transistor.

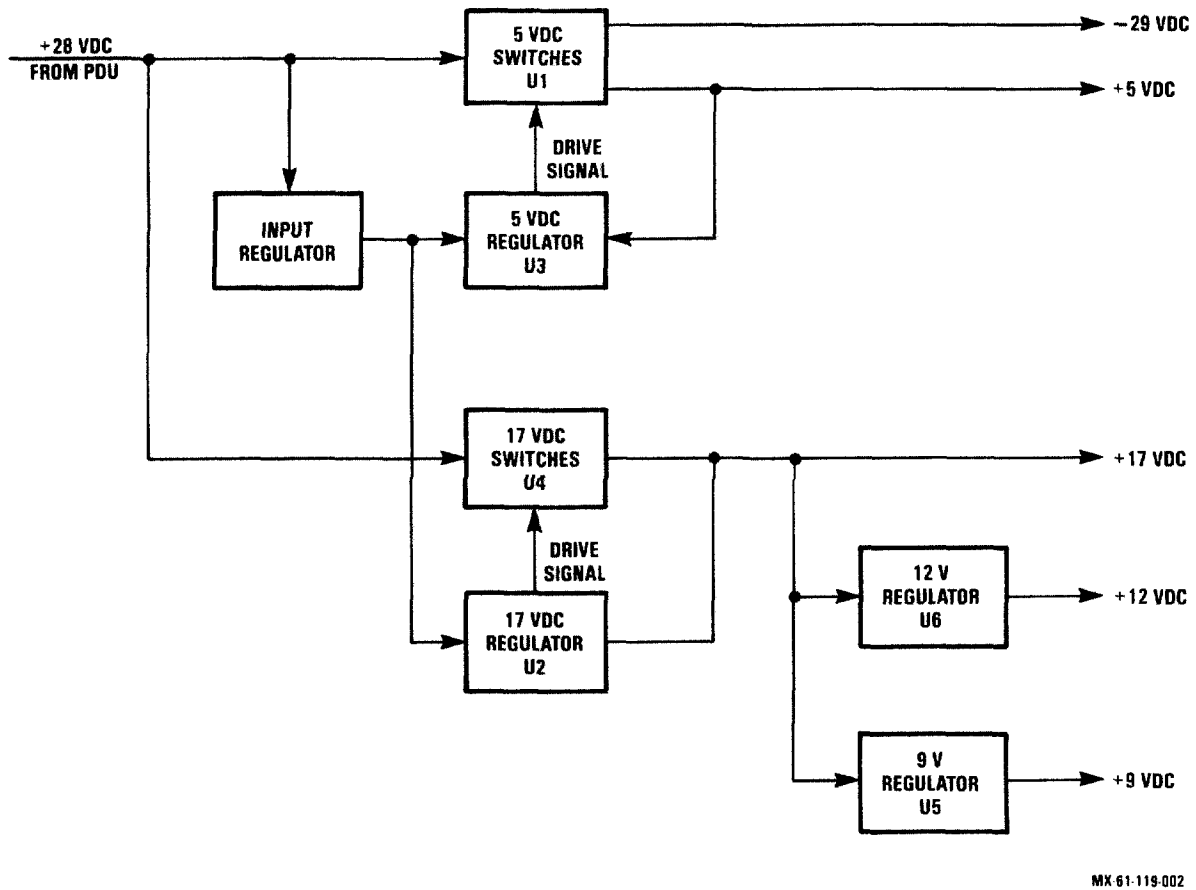

Figure 4-8. SDU Power Supply Subassembly 1A6 Block Diagram

The resulting current flow drives LED CR7, which is optically coupled through a F/O pigtail to the transmit terminal of F/O connector J1 or J2 and thus through the F/O cable to the RSC. This CCA is electrostatic-sensitive.

(1) Shunt Regulation. Shunt regulation of approximately 100 mA is provided for transistor Q2 by associated circuitry. This circuitry consists of diodes CR4 and CR5; resistors R3, R4, R5, and R6; capacitors C1 and C2; zener diode CR6; and FET Q1.

(2) Pull-Up Resistor. The circuitry composed of resistors R1 and R2, along with zener diode CR3, provides resistor pull-up voltage of approximately +5 VDC for comparator microcircuit U3 on F/O receiver CCA A2.

b. F/O Receiver CCA A2. F/O receiver CCA A2 receives signals of light through the F/O cable from the URSC. These signals are optically coupled through a F/O pigtail to the receive terminal of F/O bulkhead connector J1 or J2 and are applied to photo diode assembly CR1. The pulses of light cause the photo diode to conduct, which in turn, applies approximately +6 VDC, developed across the voltage divider, to pin 2 of microcircuit U1. The output from this preamp is applied to pin 3 of microcircuit U2. This amplified signal is again amplified and changed from an analog to a digital state in microcircuit U3. The output from this comparator is sent through pin 1, J1 and pin 10, A10J1 to the the RSC. Microcircuits U1 and U2 are electrostatic-sensitive.

(1) Voltage Divider. A voltage divider network for photo diode CR1 and microcircuit U1 consists of resistors R1 and R2 and capacitors C1 and C2. Capacitors C3, C5, and C6 filter out AC interference to ground. Positive 6 VDC voltage is applied to pin 3 of U1. Positive 12 VDC voltage is applied to pins 7 of U1 and U2 through pin 3 of connector A2J1. Coil L1 protects microcircuits U1 and U2 against transient voltage spikes.

(2) Regenerative Feedback. Regenerative feedback to pin 2 of microcircuit U1 is provided by resistors R3, R9, and R10 and diode CR4. Regenerative feedback to second-stage amplifier microcircuit U2 is provided through resistors R4 and R5 and diodes CR2 and CR3.

(3) U3 Associated Circuitry. Resistors R6, R7, and R8 and capacitors C7 and C8, along with the +12 VDC at pin 8 and ground on pins 1 and 4, configure the microcircuit as a comparator. Analog voltage inputs to U3 may be viewed at TP1, while the output receive digital signal is at a level compatible with the CMOS circuitry internal to the SDU.

4-13. RADIO SET CONTROL. Beyond the theory of operation provided for the RSC in the intermediate manual, theories of operation for depot level repairable SRUs of the radio set control are provided in this manual. Refer to paragraphs 4-14 through 4-16 for the theories of operations of the audio interface CCA digital interface CCA and the RSC regulator, respectively.

4-14. AUDIO INTERFACE CCA. The main function of the audio interface CCA is to encode and decode the serial data sent and received by the RSC. The audio and command and control (C&C) data is transferred between the RSC and the SDU by way of

the F/O link in 8-bit serial word format. The audio interface CCA decodes the words received from the SDU into audio signals and routes selected signals to the operator handsets and the speaker. Transmit audio from the operators is digitized and placed (along with C&C information) into 8-bit words which are transmitted to the SDU. (See figure 4-9.)

a. Transmit Audio Circuits. The transmit audio circuits take audio signals from the operator handsets and/or data communications terminal (DCT) data (operator 1 inputs only) and C&C data and encodes it for the F/O transmitter. Refer to block diagram figure 4-10 and schematic diagram figure FO-9.

(1) A/D Conversion. Transmit audio from panel assembly jacks J1 and J2 (operator 1) and jacks J3 and J4 (operator 2) is supplied to the audio interface CCA at jacks J1 and J2. Operator 1 transmit audio is in J1-23; return is J1-13. Operator 2 transmit audio is in J2-5; return is J1-7. The transmit audio is first applied to a three-stage buffer amplifier/filter consisting of amplifier U3A, B, and C for operator 2 and U6A, B, and C for operator 1 audio. The output of each amplifier is supplied to the respective ANLG IN inputs of two CVSD converters, U4 (operator 1), and U2 (operator 2). The CVSDs convert the audio information to digital information. The CVSD modems are used in the A/D mode only. The sampling rate clock for manual audio is 25 kHz.

(2) UART Transmit Bit Selection. After the audio signals are digitized, they must be supplied to the proper transmit bit of UART U11. The digitized audio is routed as follows:

HF-SSB to TBO  
VHF-FM to TB1  
VHF-AM to TB2  
UHF-AM to TB3  
Intercom to TB4

The output from each CVSD is supplied to a multiplexer which routes the digitized audio to the proper transmit bit of the UART. Multiplexer U21 routes the operator 1 signal, and U22 routes the operator 2 signal. The select lines of the multiplexers are supplied by outputs shift and store register U20. Selection data is transferred serially to U20 from the digital interface CCA through P2-6. The SERIAL CLOCK line clocks in the data when the TRANSMIT AUDIO CLOCK CONTROL line (from P2-8) is asserted. Parallel data from U20 is made available when the TRANSMIT AUDIO SELECT STROBE (P2-4) is asserted. The output of FF U5A controls the DATA PORT/IC CONT line. When D from register U20 is high, U5A sets and the DATA PORT/IC CONT line goes high. This allows the intercom signals from either MUX (U21 or U22) to pass through U10 D and U12F to TB4 of the UART. When DCT TC EN # is low (indicating a DCT at J1 or J2), U10D disables the intercom line to TB4 of the UART.

(3) UART Transmitter. Digitized audio is made available to UART U11 at TBO through TB4. Command and control data is presented at TB5. When the transmitter holding register load (THRL #) signal goes low, the data at TB inputs is loaded for transmission. The THRL # signal is a 25 kHz signal from FF U5B. The output of U5B is controlled by the TRANSMIT CLOCK ENABLE signal from P2-1.

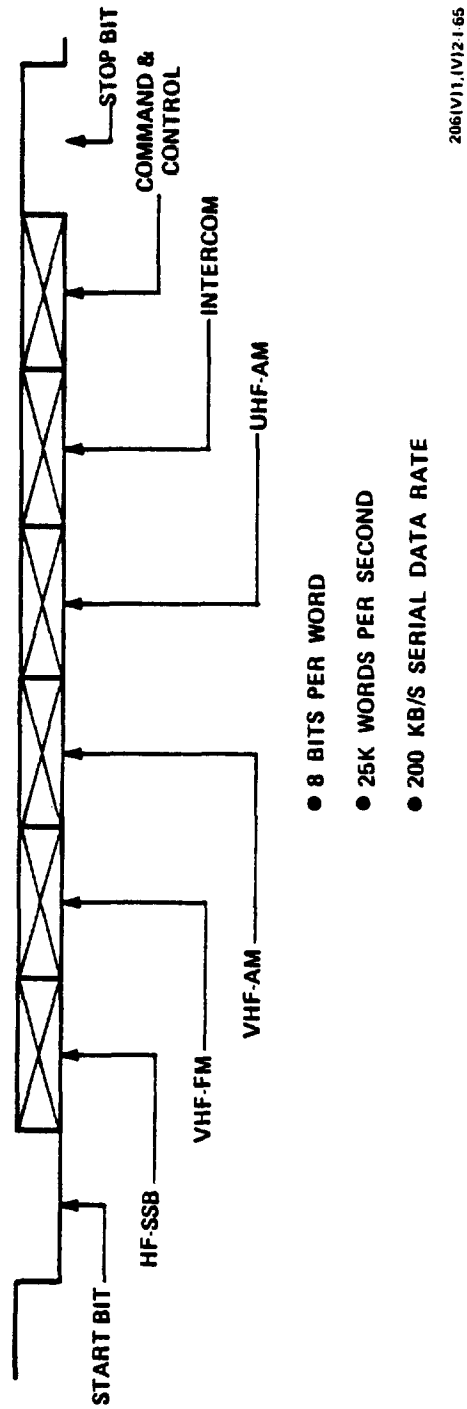
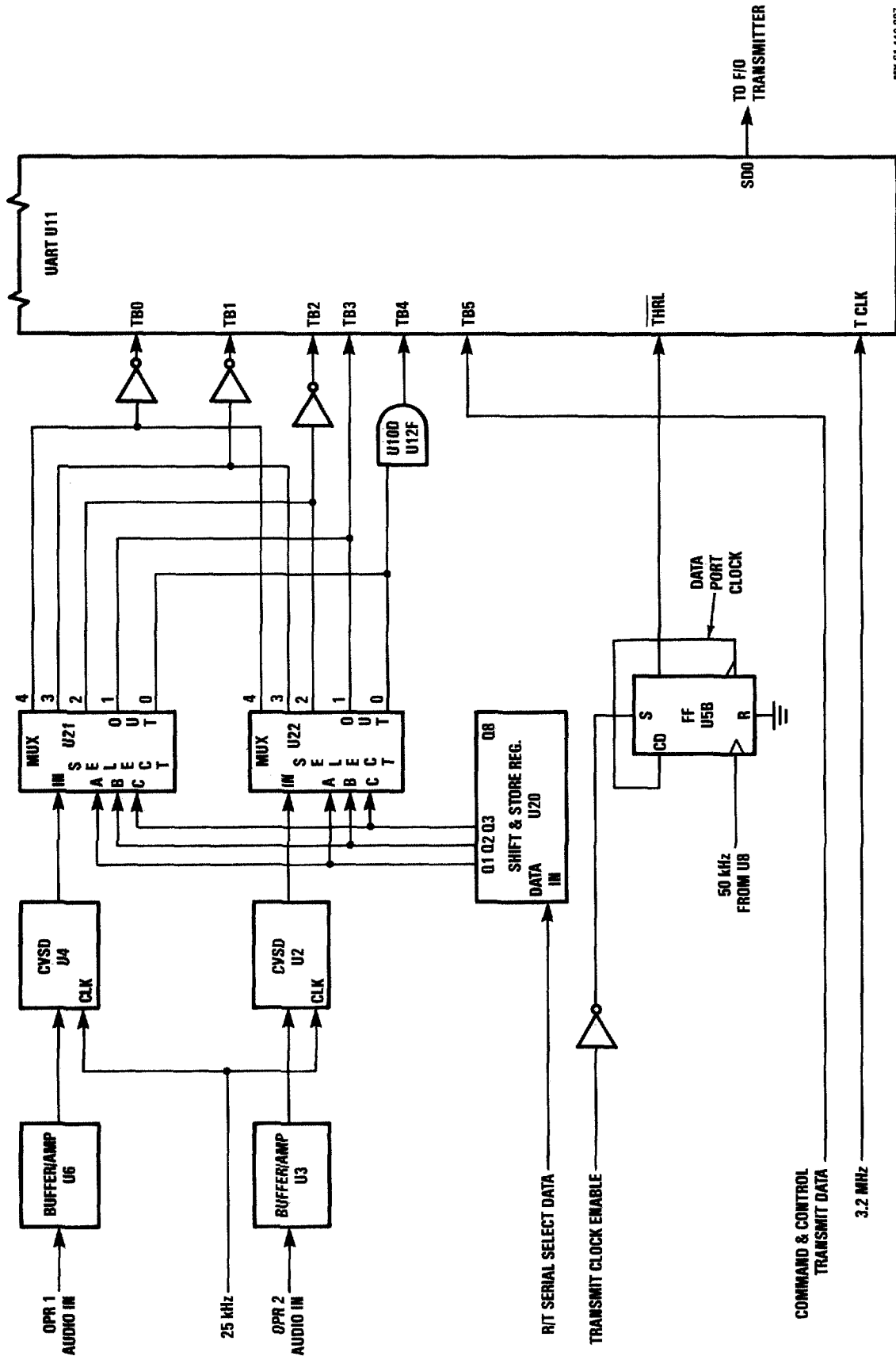

Figure 4-9. RSC-SDU Communication Word Format



MX-61-119-007

Figure 4-10. RSC Transmit Audio 5A2A2 or 6A2A2 Block Diagram

The transmit clock (T CLK) frequency is 3.2 MHz. This is 16 times the transmit rate (200 kbps). At 8-bits per word, the rate of transmission is 25 k words per second. The serial output of the UART (SDO) is then sent to the F/O transmitter through amplifier U23D and J3-4.

b. Receive Audio Circuits. The receive audio circuits take a serial bitstream from the receiver UART (in the form of 8-bit words) and output selected audio channels to the operator outputs and the speaker. The receive circuits also supply the receive C&C data. Refer to block diagram figure 4-11.

(1) UART Receive Section. Digitized audio from the SDU is received by the F/O receiver circuit and is supplied to the audio interface CCA at J3-5. The audio data, along with C&C information, is received as an 8-bit word (see figure 4-9). This serial data, which is inverted through the F/O link and receiver, is reinverted by U23C and is supplied to the serial data input (SDI) of UART U11. Digitized audio is available at the receive bus outputs RBO through RB4 as follows:

|     |          |
|-----|----------|
| RBO | HF-SSB   |
| RB1 | VHF-FM   |
| RB2 | VHF-AM   |
| RB3 | UHF-AM   |
| RB4 | Intercom |

Digitized audio from RBO through RB3 is sent directly to four CVSD modems for D/A conversion. The RB5 output is supplied directly to P2-13 (C&C receive).

(2) Intercom/Data Signal Routing. Digitized audio from RBO through RB3 is sent directly to four CVSD modems for D/A conversion. The RB4 (intercom) output is routed through analog multiplexer U17. When pin 10 of U17 is low, the digital data input of intercom modem U24 is connected to RB4. When the line is high, the digital data input of U24 is switched to the output corresponding to the selected RT (one of the RBO through RB4 outputs). This second output is selected by multiplexer U16, using the select lines from shift and store register U20. By switching between the intercom and RT channels (both of which operate at 25 K words per second), a data rate of 50 K words per second is achieved. The switching signal is produced by SR flip-flop U13B, which also synchronizes the switching signal with the DA (data available) signal from UART U11. Clock switching is also done by analog multiplexer U17 (A select, pin 11).

(3) Demodulation and Output. The digitized audio signals from the UART receive bus lines are each sent to one of five CVSD modems:

|          |     |
|----------|-----|
| Intercom | U24 |
| UHF-AM   | U26 |
| VHF-AM   | U27 |
| HF-SSB   | U29 |
| VHF-FM   | U31 |

These CVSDs are set up in identical receive-only circuits. The analog output of each CVSD is input to a filter/amplifier circuit using operational amplifiers U25A (intercom), U25B (UHF-FM), U28A (VHF-AM), U28B (UHF-AM), and U30A (HF-SSB). The

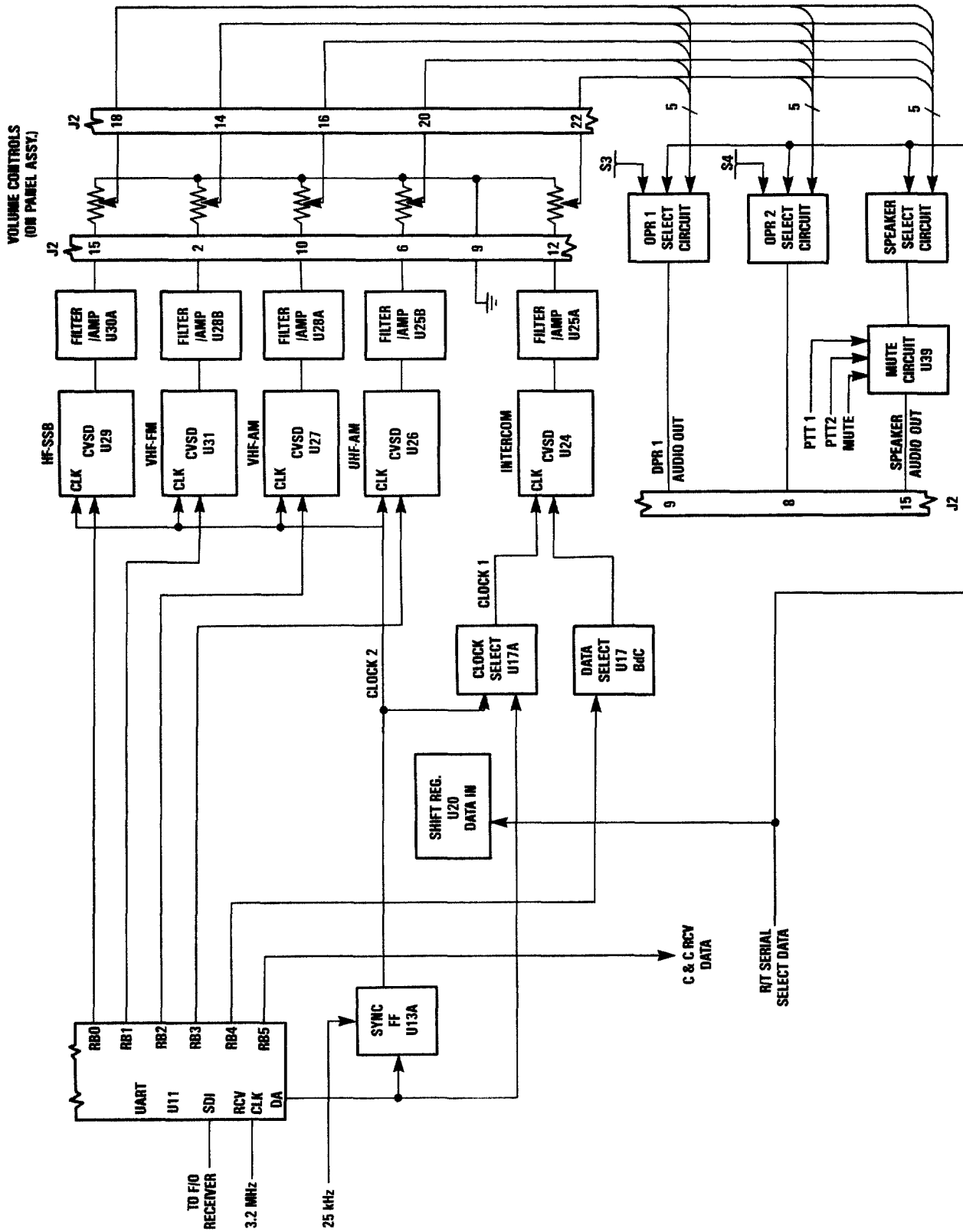

MX-51-119-006

Figure 4-11. RSC Receive Audio 5A2A2 or 6A2A2 Block Diagram



output of each filter/amplifier circuit is sent to a volume control on the RSC panel assembly. The audio from the volume controls is supplied to analog multiplexers U33, U34, U37, and U38. These multiplexers are controlled by shift and store registers U32 and U36. Data from the digital interface CCA are sent serially to U32 and U36, which direct the multiplexers to supply the proper audio channel to operators 1 and 2 and the speaker. The audio for operator 2 is output directly to J2-8. A summing network operates by microcircuits U32 and U36 enabling the analog switches U33, U34, U37, and U38. These connect the appropriate audio channels to the 6dB resistor pads R130, R134, and R139, which allow each operator to monitor background audio channels (attenuated 6dB) while using the primary channel. The background audio channels are also visually indicated on the RSC control panels. The speaker-muting circuit consists of NAND gates U39C and U39F, which drive inverter U39B controlling Q7. Speaker audio is amplified by U46 and U45.

(4) Open Cable Indicator Circuit. In the event the UART does not receive incoming serial data, the lack of a regular DA (data available) signal triggers the open cable indicator circuit. This circuit consists of NAND gates U10C and U19B, comparators U23A and U23B, and decode counter U18. Decode counter U18 is kept in counting mode with an input clock of 195 Hz. If the DA signal does not arrive before a carry state is reached (approximately 5 ms from start of count), the COUNT CARRY asserts, latching the OPEN CABLE INDICATOR line high. The 400 Hz open cable indication will remain on. The system is reset by powering down and powering back up.

4-15. DIGITAL INTERFACE CCA. The main function of the digital interface CCA is to communicate C&C information between the RSC and the SDU. The C&C information from the SDU includes frequency readout display data, transmit and receive audio selection information, and DCT status. The digital interface CCA transmits such information as RSC switch positions, keyboard key pressed, and operator PTT status. Refer to the digital interface CCA block diagram figure 4-12 and schematic diagram figure FO-10.

a. Operator Control Input Circuits. The RADIO TRANSMIT switches S3 and S4 can each select one of six positions (IC, HF-SSB, VHF-FM, VHF-AM, UHF-AM, and OFF). Six select lines from each switch enter the digital interface CCA at J3-5, -1, -11, -7, -3, and -8 (OPR 1 switch S3) and J4-9, -5, -3, -7, -14, and -22 (OPR 2 switch S4). The selected line is grounded. All other lines are pulled high (+9 VDC) by resistors in resistor packages R17 (OPR 1 lines) or R18 (OPR 2 lines). The six select lines from each switch are input to an 8-bit priority encoder (U11 for OPR 1 and U12 for OPR 2 lines). Each encoder outputs a 3-bit code corresponding to the switch position. The 3-bit code for the OPR 1 lines, along with the PTT 1 line (from J3-9), is input to 4-bit latch U13A. The 3-bit code for OPR 2 lines and the PTT 2 line (from J4-24) are input to 4-bit latch U13B. These latches have three-state outputs and act as buffers to the UART transmit bus. When these latches are enabled by the C&C OUTPUT ENBL signal from the EPROM state circuit, the eight bits from the RADIO TRANSMIT and PTT switches are placed on the UART transmit bus as follows:

|                     |   |                               |
|---------------------|---|-------------------------------|
| bit 0               | - | PTT 1                         |
| bit 1 through bit 3 | - | operator 1 select switch code |
| bit 4               | - | PTT 2                         |
| bit 5 through bit 7 | - | operator 2 select switch code |

b. Keyboard Input Circuit. The keyboard switches are arranged in a 5 x 5 matrix pattern (see figure 4-13). Decode counter U36 sends a low pulse through decoders U35A and U35B to each of the columns of the keyboard matrix columns (C1 through C5) in sequence. When a key is pressed, a low will appear on the row line (one of R1 through R5) when the corresponding column line goes low. A low on any of the row lines (normally pulled high by resistor package R25) causes the output of NAND gate U37 to go high. When the output of U37 goes high, the Q output of FF U38A goes high, stopping U36 (the column sequence counter) from counting. At the same time, the Q output of U38A starts decode counter U39. After ten cycles of the 312.5 Hz clock, the COUNT CARRY output of U39 goes high, setting FF U38B, which enables the EPROM U40. The COUNT CARRY output of U39 also resets FF U38A, which restarts counter U36 and sets the LOAD/COUNT input of counter U39 to LOAD. The Q output of FF U38B signals the EPROM state circuit that keyboard data has been presented to EPROM U40. The KYBD OUTPUT ENBL line from the EPROM state circuit (available at TP 25), which is asserted low, goes low to present the output of keyboard EPROM U40 to the C&C UART transmit bus. The DATA AVAIL RST line (also from the EPROM STATE CIRCUIT) resets FF U38B, removing the CHIP ENBL signal from EPROM U40, preventing changes in the state of the EPROM.

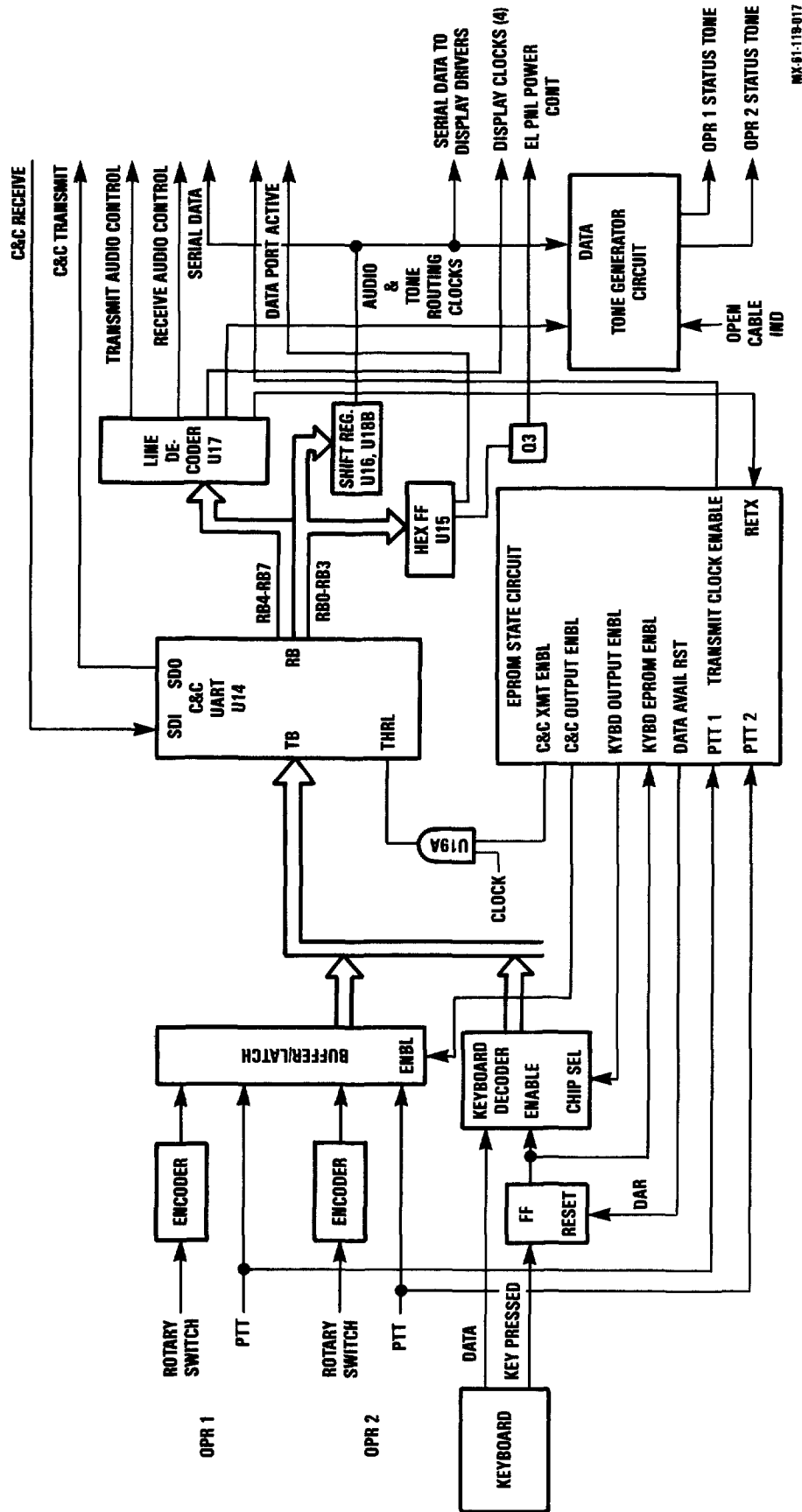
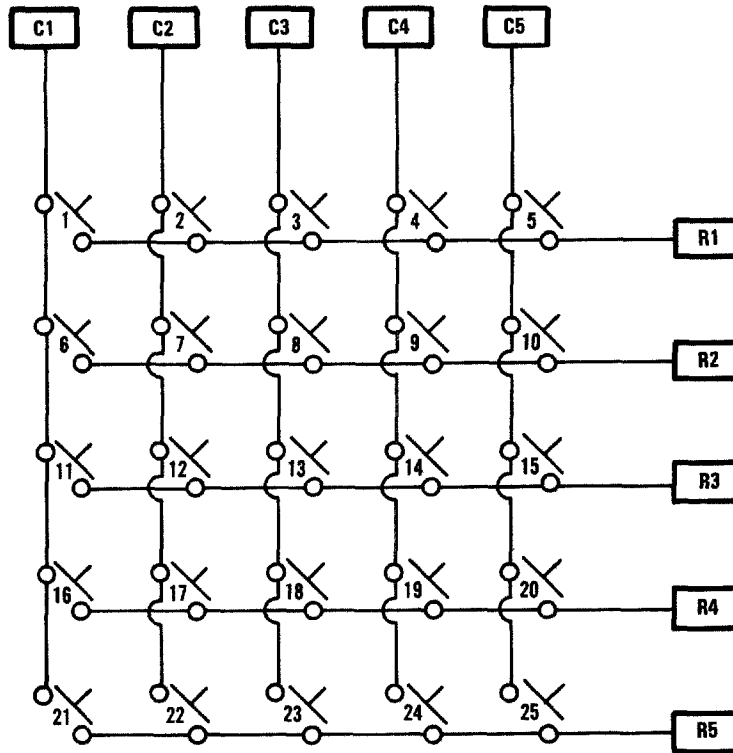

Figure 4-12. Digital Interface CCA 5A2A1 or 6A2A1 Block Diagram

MX-61-118-017



MX 61-119 018  
REF MX DWG NO. 826483 REV K

Figure 4-13. RSC Keyboard Schematic Diagram

c. EPROM State Circuit. The EPROM state circuit controls the flow of data into the transmit bus of the C&C UART. The status of PTT 1, PTT 2, and the keyboard EPROM enable lines is input to the address lines of U41 (A0, A1, and A8, respectively). Address lines A3 through A7 are connected to the outputs of FF U42, which stores the state of outputs 01 through 05 from U41. Address line A2 is the output of the RETX FF, U10A. The eight output bits of U41 depend therefore upon the PTT1, PTT2, keyboard EPROM enable, RETX status, and the last state of outputs 01 through 05. The state of the EPROM state circuit is therefore determined by the outputs of U41. The actual outputs of the EPROM state circuit are determined by EPROM U44. The outputs of U41 are used as the address inputs of U44, which determines the actual outputs. The outputs of EPROM U44 are stored by hex FF U45. The loading of FF U45 and EPROM U44 is synchronized by a 312.5 Hz clock from FF U10B. A +9 VDC monitor circuit consisting of comparator U8D, R28 through R32, C25, CR5, and inverter U20D resets the output FF U45 if the +9 VDC power level drops. There are five outputs from the EPROM state circuit. C&C XMT ENBL controls the transmit clock of the C&C UART. DATA AVAIL RST controls the data going to the keyboard EPROM. KYBD OUTPUT ENBL selects the keyboard data as input to the C&C UART transmit bit. C&C OUTPUT ENBL selects RADIO TRANSMIT/PTT switch data as input to the C&C UART transmit bus. TRANSMIT CLOCK ENABLE controls the THRL# line of the communications UART on the audio interface CCA.

d. C&C UART Transmit and Receive Circuits. Data presented at the transmit bus of C&C UART U14 is loaded for transmission when the C&C XMT ENBL is high. The C&C XMT

ENBL line controls the 312.5 Hz clock to the THRL# input of the UART through NAND gate U19A. The 50 kHz transmit clock (TCLK) and receive clock (RCLK) inputs to UART U14 are both from the  $Q_1$  (pin 14) output of decode counter U21. Decode counter U21 has as an input the 100 kHz line from J4-11 and outputs 10 kHz from its CARRY OUT output. The 10 kHz clock from U21 is divided further by binary counter U22, which supplies 1.25 kHz (pin 6), 625 kHz (pin 5), 312.5 Hz (pin 3), and 78 Hz (pin 4) to circuits in the RSC. The serial C&C output data from U14-25 (C&C transmit) is sent to the audio interface CCA through J4-12. Serial C&C data from the audio interface CCA (C&C RECEIVE) is delivered to the digital interface CCA at J4-13 and is applied directly to the SDI input (pin 20) of the C&C UART U14. The UART receive bus lines RB4 through RB7 are inputs to 4-to-16 line decoder U17. Each combination of the four input bits causes a high output at one of the 16 outputs. The serial output of U16 is the SERIAL DATA line, which supplies data to the tone generator circuit and the displays. The SERIAL DATA line, after a 20 us delay in shift register U18B, is output at J4-6 as SERIAL DATA AUDIO INTERFACE. The RB2 and RB3 outputs of the UART are also used to control the EL PNL POWER CONTROL. The RB2 and RB3 lines are input to FFs in hex FF U15. When a clock pulse from output 7 of line decoder U17 is received at the clock input of U15, the data present at the RB2 and RB3 outputs of the UART is loaded into the FFs. The status of RB2 controls transistor Q3, which controls the EL PNL POWER CONTROL line to J2-4.

f. Operator Status Tone Generator Circuits. Various error conditions such as an open F/O cable, secure radio in use, BITE/fault alert, etc., required that a specific audio tone be supplied to the appropriate operator handset. The audio data is obtained from the SERIAL DATA line and is clocked into bus registers U27 and U28 when the AUD TN SHF CONT line from line decoder U17 is high. The B8 output of U27 is cascaded into U28. The data from U27 and U28 is provided to the inputs of two BC down counters U29 and U30, which are clocked at twice the frequency (100 kHz as opposed to 50 kHz) of U27 and U28. The CARRY OUT outputs of counters are fed back to their SYNC ENBL inputs. The CARRY OUT of U29 is sent to FF U34B, and the CARRY OUT of U30 is sent to FF U34A. These FFs are set up to divide the CARRY OUT signals by two. The Q outputs of these FFs are the two audio tone signals. A selection circuit controlled by shift and store register U31 controls the routing and timing of the tones. Tone routing data is clocked into U31 from the SERIAL DATA line when the TN ROUTING DATA CLK CONT line enables the 50 kHz clock through AND gate U32A. Four bits of data in the first four FFs of U31 determine which tone is supplied to which operator. A high level at the first FF (U31-4) enables NAND gate U33D, sending the tone from FF U34B to the OPR2 STATUS TONE line through AND gate U32D. A high level at the second FF of U31 (U31-5) enables NAND gate U33C, sending the tone from FF U34A to the OPR 2 STATUS TONE line through AND gate U32D. A high level at the third FF of U31 (U31-6) enables NAND gate U33B, sending the tone from FF U34B to the OPR 1 STATUS TONE line through AND gate U32C. A high level at the fourth FF (U31-7) enables NAND gate U33A, sending the tone from FF U34A to the OPR 1 STATUS TONE line, which leaves the digital interface CCA at J3-12. The OPR 2 STATUS TONE line leaves at J4-19. In the event of an open F/O cable, the OPEN CABLE IND line from J4-2 goes high. This causes the PRL/SER lines of tone-generating registers U27 and U28 to go high, loading lows in the registers from the parallel inputs. The OPEN CABLE IND line, after being inverted by U20E, also disables tone-routing shift and store register U31. This allows the signal from counters U29 and U30 (a 390 Hz tone) through to both operator status tone lines.

g. Display Circuits. Data from the SERIAL DATA line is clocked into the display drivers (U1 through U5) when the display clock control line (from the EPROM state circuit) for that particular display is asserted. The display drivers provide the data for each segment of their respective displays in parallel form. The displays are strobed at a rate of 78 Hz by connecting a 78 Hz clock to the display backplane. The open cable and low battery displays are enabled by synchronizing the OPEN CABLE DSPL and LOW BATT DSPL lines with the 78 Hz clock. These displays are disabled by synchronizing them with an inverted 78 Hz clock. This clock selection is done by the exclusive ORing of the 78 Hz clock with the OPEN CABLE IND (at U9A) and the low battery line (at U9C). A low on the OPEN CABLE IND line produces the 78 Hz clock at the output of U9A; a high produces an inverted clock. An open cable or low battery situation therefore causes the appropriate indication to appear on the display.

h. Power Distribution Circuits. Operating voltages are derived from battery source during remote operation (RSC located more than 20 feet from SDU) and from the SDU interconnecting power cable during local operation. Battery inputs are at J1 and J2 of the case assembly. External power from the SDU is connected to case assembly connector J6. The +28 VDC voltage is routed through the A2A2 CCA to the A2A1 CCA (J3-6) and is connected on A2A1 (J5, J6, J7, J8) for LCD heater power. The LCD temperature sensors are positive coefficient resistors, e.g., decrease in temperature (J3-6), and is connected on A2A1 (J5, J6, J7, J8) for LCD heater power. At normal ambient temperatures, current flow stops and no heat is applied to the LCD. During battery operation, the +12 VDC voltage entering J4-14 is routed to F/O transmitter assembly A1A4. The +17 VDC voltage is routed to A1A1, a shunt power supply that provides +17 VDC to the speaker and the A2A2 CCA. Circuits within the A2A2 CCA produce the +9 and +14 VDC for component operation. Additionally, power is routed to the backlighting driver (A1A2) for panel lighting. The panel-lighting driver contains a DC/AC inverter card which changes the DC input to 100 VAC 400 Hz output. The output is varied and switched by the A1R1 dimming control. The power is then routed through the A2A1 CCA for display and keyboard lighting. The +14 VDC output is monitored on the A2A1 CCA. During operation, should battery power decrease below the limits of the required regulated output, exclusive OR gate circuits contained on the A2A1 CCA produce a low battery indication on the front-panel status annunciator.

i. Operator Audio Circuits. The digital interface CCA also houses the amplifiers for the operator 1 and operator 2 handset audio. Audio from the OPR 1 volume control is taken from J3-4 and J3-17. This audio is amplified by U24 and is output (to the audio interface CCA) at J3-19 and J3-20. Audio from the OPR 2 volume control is taken from J4-20 and J4-21 and is amplified by U26. The outputs of this amplifier are at J4-16 and J4-18.

4-16. RSC REGULATOR. The RSC regulator is a subassembly of the case assembly, which is a part of the RSC. Positive 17 VDC voltage is routed to the RSC regulator, a shunt power supply that provides +17 VDC to the speaker, and the A2 audio interface. The shunt power supply contains circuitry for battery power, +17 VDC, shunted speaker power, shunt regulator control, shunted +17 VDC, and +17 VDC shunted regulator control.

- a. Battery Power Circuitry. Refer to FO-11. The battery power is input through J1-18, -20, -22, and -24. Diodes CR1 through CR4 ensure correct current flow to output J1-16, also.
- b. Positive 17 VDC. Positive 17 VDC voltage is input through J1-6 and is applied to the shunted speaker power and shunted +17 VDC circuits. The +17 VDC is also output directly through connector J1-5.
- c. Shunted Speaker Power Circuitry. The shunted speaker power circuitry provides speaker power. It consists of PNP transistors Q1 and Q2; resistors R1, R2, and R3; capacitor C5; and diode CR5. SPEAKER POWER OFF/ON # pin 10, connector J1 allows forward biasing of PNP transistor Q2 across diode CR5 and resistor R2. This, in turn, forward biases Q1, and current flows through resistor R3, through J1-1 and -2, as the shunted speaker power to the audio interface CCA A2A2, and regulator plate assembly A1A3. SHUNT REGULATOR CONTROL at J1-3 goes to regulator plate assembly A1A3 where it regulates the SHUNTED SPEAKER POWER at J1-1.
- d. Shunt Regulator Control. The shunt regulator control consists of PNP transistor Q3, resistors R4 and R5, and capacitors C1 and C2. Q3 is forward biased across R4 during SHUNTED SPEAKER POWER use, and a control current passes through J1-3 to regulator plate assembly A1A3. Capacitors C1 and C2 provide filtering of unwanted AC. Resistor R5 develops voltage which helps to provide the forward biasing of Q3. The output level of the shunt regulator is controlled through J1-3 from the regulator plate assembly A1A3. A higher voltage at the collector of Q3 shows conduction through which Q3 slows the current flow through Q2, the heart of the circuit. Current is regulated through Q1 by its collector being tied to the collector of Q2. Thus, when current flow increases through Q1, a more positive collector is felt at Q2, which decreases current through that device, which in turn restricts the current through Q1.
- e. Shunted +17 VDC. The SHUNTED +17 VDC current at J1-7 is regulated in the regulator plate assembly A1A3. There two power transistors are tied together at their collectors. These, in conjunction with Q4, regulate the +17 VDC through J1-7. When current increases across resistor R6, R7 applies a more negative-going voltage to the base of Q4, which slows the conduction of the power transistors in regulator plate assembly A1A3. This decreases the current passing through J1, 7, and 8. In the same way, decreased current across resistor R6 will increase the forward bias of Q4 through R7, which increases the current flow through J1-7. Capacitors C3 and C4 and resistor R8 guard against unwanted AC and serve to correctly bias Q4.
- f. DC and Speaker Power Return Circuits. J1-4, -11, through -15, -17, -19, -21, -23, -25, and -26 provide return to GND for the DC and SPEAKER POWER RETURN.

4-17. FM BITE/AUDIO INTERFACE ASSEMBLY. The VHF BITE panel provides the audio interface connecting the VHF-FM radio, the SDU, and the KY-57 encryption device (when installed in AN/GRC-206(V)1). It also provides BITE capabilities for the VHF-FM subsystem. The VHF BITE panel includes five external connectors (J1 through J5) and an FM BITE/audio interface CCA which mounts the circuitry necessary to provide the audio switching and BITE capabilities. Circuits contained on FM BITE/audio interface CCA A1 are described in the following subparagraphs (see figure 4-14 and FO-12).

a. FM BITE Circuits. The FM BITE circuits include a shielded transformer (T1), bandpass filter, comparator, and voltage reference circuit. Transmitter power in route to the VHF-FM antenna is interfaced through VHF BITE panel connector J2.

(1) Bandpass Filter Circuit. The bandpass filter circuit consists of coupling capacitor C5 and resistors R6 and R10. Signal detection and filtering are accomplished by diode CR4, capacitor C4, and coil L1. Resistors R8 and R9 act as a voltage divider and couple the signal voltage to pin 3, noninverting input, of microcircuit U3A.

(2) Reference Voltage Circuit. The reference voltage circuit consists of resistors R4, R5, R11 through R13, and R17. Also included in the circuit are capacitors C1 and C2, diodes CR2 and CR3, and zener diode CR1. Positive 12 VDC voltage is supplied through R4 to 6.2 V zener diode CR1. This regulated voltage is divided across resistors R11, R12, and R13. Approximately 1 VDC voltage (view at TP1 or pin 2 of U3A with oscilloscope) is applied to pin 2, inverting input, of microcircuit U3A. Diodes CR2 and CR3, resistor R5, and capacitors C1 and C2 determine the approximate one-half (-3 dB) of the normal output power of the transmitter. When the bandpass filter voltage at pin 3 of U3A falls below the reference at pin 2, the comparator conducts. The amplified output of comparator microcircuit U3A is divided between R18 and R19 and is applied to the base of NPN transistor semiconductor Q1. Q1 conducts; voltage is developed across R4, R7, and R20 and is felt at J3-30 as a high or fault signal. The normally low output at J3-C goes high, indicating BITE fault. This BITE fault is routed to the SDU which generates and outputs the appropriate C&C data to the active RSC. The active RSC then alerts the operator with an audible alarm and visual FAULT indication. J3-28 is wired to R11. XA1P1-28 is not used. J3-29 is wired to TP1 and U3A-2. XA1P1-29 is not used. Microcircuit U3 is electrostatic-sensitive.

b. Audio Interface Circuits. The audio interface circuits include a triple two-channel multiplexer U2A, U2B, and U2C (only U2A and U2B are used) and NOR gate logic circuitry.

(1) Triple Two-Channel Multiplexer. The triple two-channel multiplexer circuitry consists of microcircuit U2; capacitors C6, C7, C8, and C9; diodes CR5 and CR6; and resistors R15, R16, R21, R22, and R23. Microcircuit U2 is a digitally controlled analog switch. U2 is electrostatic-sensitive. U2A receives X MODE IN (RCVR) from J4-E (VHF-FM), through P1-8 and J3-8 across capacitor C7 to pin 14 (A COM). A logic high (SQUELCH DISABLE) from J4-M through XA1P1-25 and J3-25 passes through diode CR5 to A SEL (pin 11) on U2A. When signals appear concurrently at pins 14 and 11 of U2A, the X MODE OUT (RCVR) analog signal is output and passes through J3-10 and XA1P1-10 to J4-F. When KY-57 is installed, a SQUELCH CONTROL logic low pulse is applied through J5-B of connector J5 (KY-57). The signal passes through XA1P1-7 and J3-7 and appears at A SEL, pin 11 of U2A to cause no output (logic low) at A1 (pin 13). When SQUELCH CONTROL is absent, the logic high, developed across R1, causes U2A to continue to output. SQUELCH CONTROL logic low (from KY-57) is also felt across diode CR6, out J3-11 and XA1P1-11 as TONE MODE on J4-H (VHF-FM). It is also felt as a logic low through J3-14 and XA1P1-14 and sent as TONE K401-5 (J4-G) to the VHF-FM X MODE. KY-57 will always receive X MODE IN (RCVR) from J4-8 as RECEIVER CIPHER TEXT on J5-G.



(2) NOR Gate Circuitry. The NOR gate circuitry consists of NOR gates U1A and U1B and resistors R1 and R2. The NOR gate circuitry is activated only when KY-57 is installed; the circuitry is electrostatic-sensitive. NOR gate U1A receives PT IND (plain text indication) from connector J5-A of KY-57. This logic high (when PT IND is present) passes through XA1P1-6 and J5-6 and is applied to pins 1 and 2 of NOR gate U1A. Pins 1 and 2 are held normally at a logic high by the +12 V and resistor R2, so the inverted output of the NOR gate is normally a logic low unless PT IND (ground) is applied to pin 2. When PT IND is applied to pin 2, the output at pin 3 will go to a logic high, which is applied to pin 9 of NOR gate U1B. The output at pin 10 of this NOR gate is held low by a logic high input from resistor R1 and a logic low from NOR gate U1A in its normal state. When a SQUELCH DISABLE or TONE MODE logic low (ground applied) arrives from J4-M or -H (VHF-FM) through XA1P1-25 or -11 and J3-25 or -11, it passes through diode CR5 or CR6 and is applied at pin 8 of NOR gate U1B. If, at the same time, a PT IND signal has switched NOR gate U1A to a high output, pin 9 of U1B becomes a logic high state, and U1B outputs a logic low signal. This is routed through J3-5 and XA1P1-5 and on through J3-B (SDU) at CT/PT #. This line is normally high. When low, it signifies that the KY-57 is transmitting or receiving CT.

(3) Wiring. Except for pins A and K, J5 (KY-57), all the wiring from KY-57 use connectors XA1P1 and J3 as jumpers for connection to J4 (VHF-FM). Of these, J5-B, -C, -D, -F and -G also make connection with other components or circuitry on the FM BITE/audio interface CCA. Pins A and E, J3 (SDU) also use XA1P1 and J3 as a jumper to ground. All the wiring from connector J5 (KY-57) is shielded and grounded to pin L, J4 (VHF-FM), except for pins A, B, J, and K. Wires J4-B, -C, -D, -E, -F, -G, -H, -J, and -K (VHF-FM) are also shielded and grounded. developed across R1, causes U2A to continue to output. SQUELCH CONTROL logic low (from KY-57) is also felt across diode CR6, out J3-11 and XA1P1-11 as TONE MODE on J4-H (VHF-FM). It is also felt as a logic low through J3-14 and XA1P1-14 and sent as TONE K401-5 (J4-G) to the VHF-FM X MODE. KY-57 will always receive X MODE IN (RCVR) from J4-8 as RECEIVER CIPHER TEXT on J5-G.

4-18. PANEL INTERFACE CCA (see figure 4-15, and FO-18). The function of the Panel Interface CCA is to provide a signal path between the Control Panel and the RT-1209 Modification Kit in normal (local) operation. It also provides a path for the transmit and receive mode select signals in local and remote operations. The Panel Interface CCA receives 28 frequency select signals, two mode select signals, the "frequency charge" signal, the lower sideband select signal, and two volume control signals from the Control Panel. It utilizes the REMOTE SELECT, and REMOTE SELECT# control signals and receives the remote transmit mode signals B0, and B1 from the SDU Interface CCA. It receives four remote mode select signals from the RT Interface CCA.

a. Frequency Select Signals. The Frequency Select signals (BCD logic data) from the Control Panel are received directly thru 28 P1 connector pins as shown on FO-18 (Sheets 3 and 4). These signals are supplied by the six Control Panel switches S1

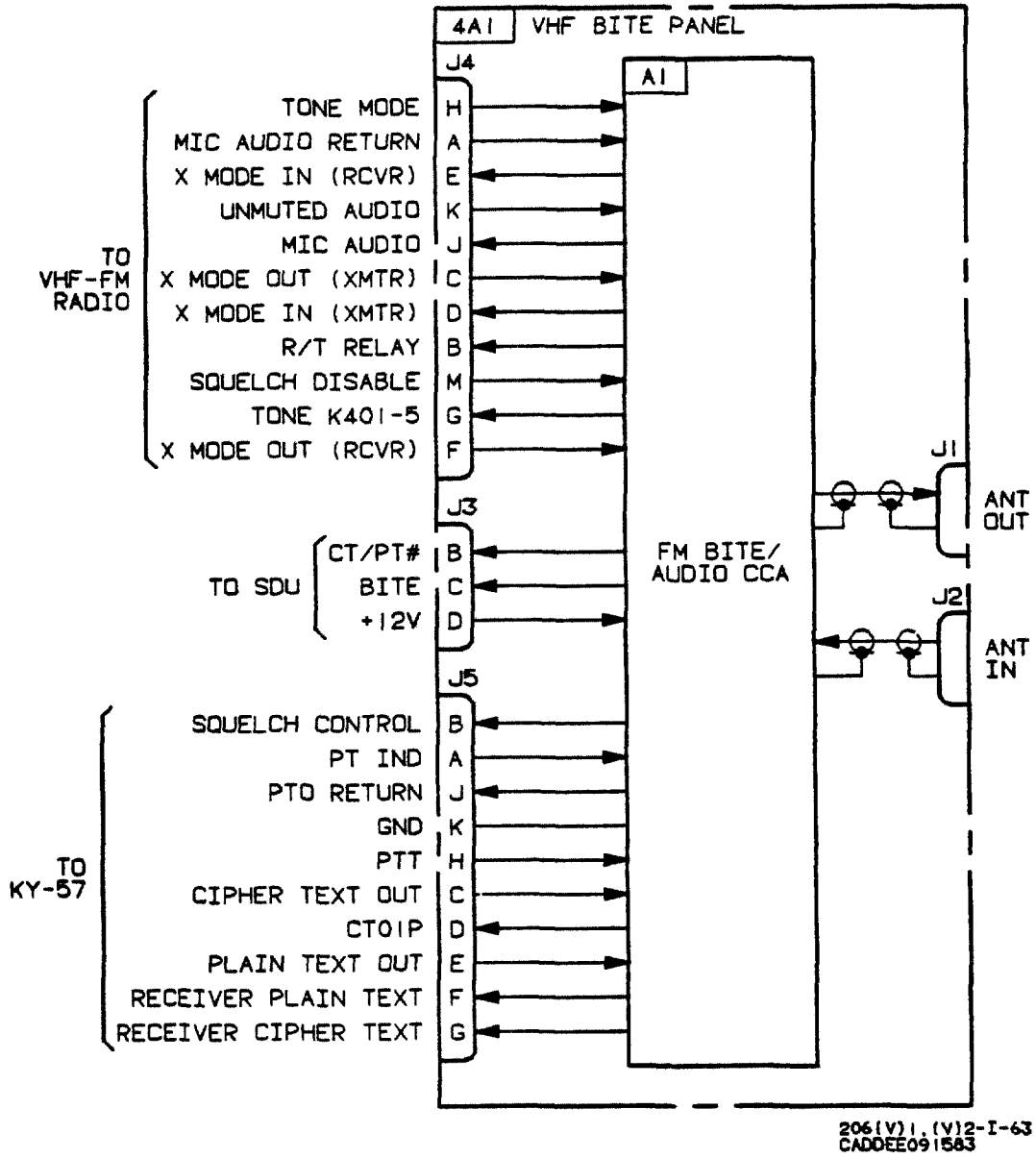

Figure 4-14. VHF BITE Panel 4A1 Block Diagram

thru S6, which allow receiver tuning of frequencies from 2000 to 29,999 KHz. The "frequency change" signal ( $\Delta F$ ) indicates when a new frequency is selected (Refer to technical manual TM-07748A-45/2 for a more complete description of the Control Panel Frequency KHz Switches). These signals then pass through 5 tri-state buffers. The frequency select output signals ("frequency select bus") are sent to the RT Interface CCA via connectors J2 and J3 and then, in normal (local) operation, on to the synthesizer. In remote operation REMOTE SELECT, from the SDU Interface CCA, goes high and disables the outputs of these buffers causing the signals not to be available at the J2 and J3 connectors.

b. Volume Control. Volume control for the RT-1444 can be accomplished directly using the control panel in normal (local) operation or the volume is established at a fixed level in remote operation. Volume control mode switching is accomplished by analog switch U9. The switch is wired so that in normal (local) operation the volume is adjusted by voltages coming from the pot on the Control Panel via connector P1-37, and 38. The output from this pot is also used to determine the squelch level for the Squelch Detect circuit on the SDU Interface CCA. In remote operation, the signal REMOTE SELECT# causes the switch to be oriented so that the volume level is established by the voltage divider network R3, and R4.

c. Transmit mode signals. The signals related to the transmit mode, XMT ENABLE, DATA ENABLE, LSB, PTT, and CW KEY, along with  $\Delta F$  (a receive mode signal), are sent from the Control Panel, and received at connector P1. The four signals, XMT ENABLE, DATA ENABLE, LSB, and  $\Delta F$  are inverted by buffer/inverter U6. Signal LSB is first inverted by "Darlington" buffer/inverters U7 before going to U6. These four signals are then combined in a tri-state configuration with signals SOB2, SOB3, S7B2, and S7B3, which are received from connector J2. The four J2 signals contain remote transmit instructions, and are received from the RT Interface CCA. The combined U6 and J2 tri-state outputs are applied to the inputs of seven-input "Darlington" buffer/inverter U7. Signals LSB and TX ENABLE are applied to two inverting saturated switching circuits (Q1 and Q2), and sent to the RT-1444 Modulator/Demodulator via the SDU Interface and the RT Interface CCA. Signals PTT and CW KEY are applied to connector J2 and J3 and then sent directly to the RT via the same two CCA's.

(1) Local Transmit Mode. In local operation REMOTE SELECT#, the disable input for U6, is low allowing its output signals to be passed to the input of U7. These Control Panel transmit instructions then pass to Rt-1444 via the RT Interface CCA. At this time signals SOB2, SOB3, and S7B3 do not appear on J2.

(2) Remote Transmit Mode. In remote operation, the Transmit instructions are supplied by connector J2. REMOTE SELECT goes high disabling the output of U6. At the same time, J2 signals SOB2, SOB3, S7B2, and S7B3 are connected to the inputs of the "Darlington" buffer U7 and passed on to the RT Interface CCA.

(3) Transmit Start Signals. The signals PTT, and CW KEY are also received from the Control Panel and are passed to the Modulator assembly via connectors J1 and J2 when in local operation. In remote operation, these instructions are developed by shift register U8 from data bits B0, and B1 which are received on connector pins

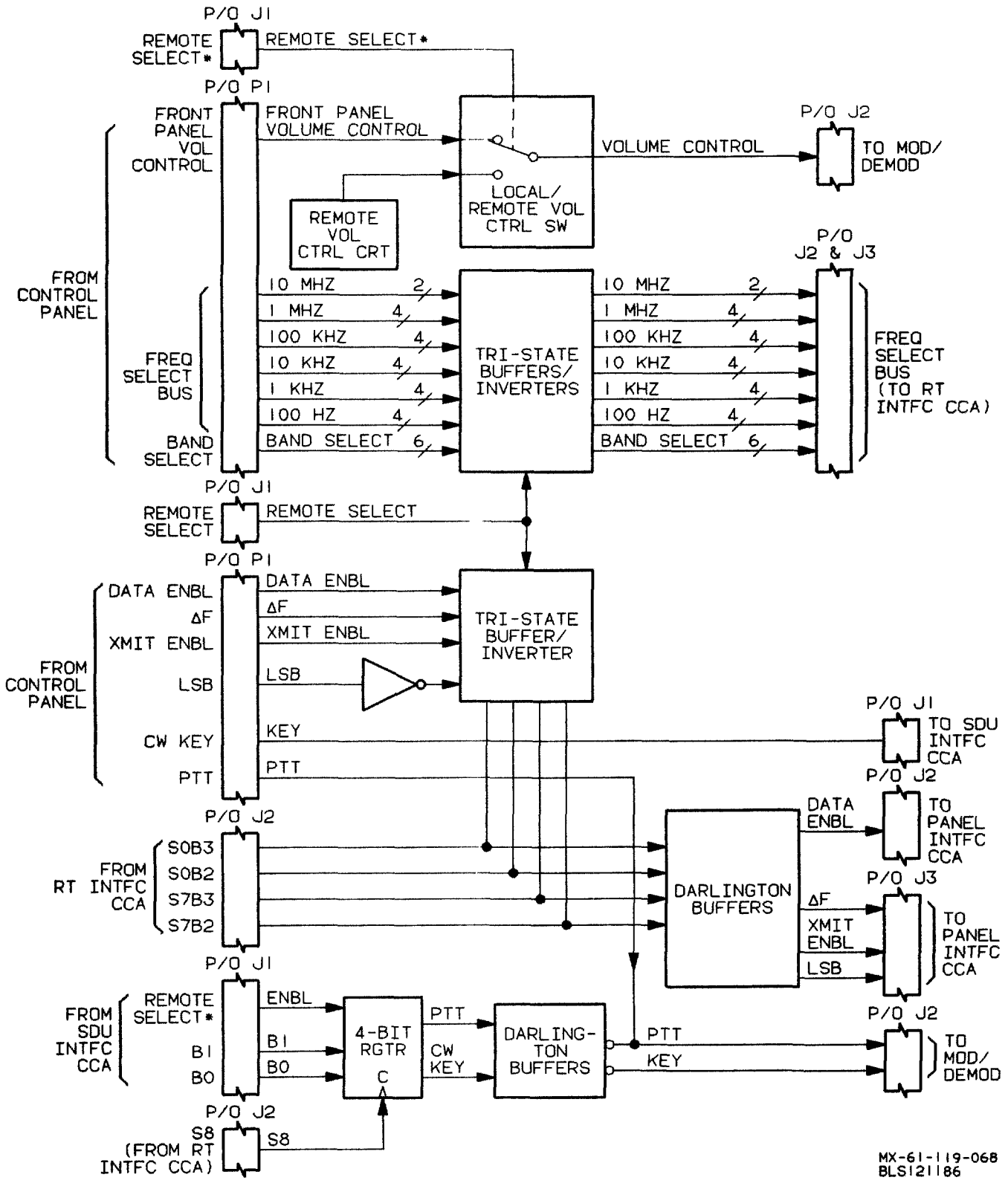

MX-61-119-068  
BLS121186

Figure 4-15. Panel Interface CCA Block Diagram

J1-18, and 19. These bits are part of the 8-bit parallel data word from the SDU Interface CCA. The clock for the shift register is signal S8 which comes from the RT Interface CCA and received on connector J2-26. At this time, REMOTE SELECT# is low allowing the shift register outputs to be available to the remaining two inputs of "Darlington" inverter U7. The outputs of U7 (PTT and CW KEY) are sent to J2 pins 7 and 3 respectively then passed to the Modulator/Demodulator via the SDU and RT Interface CCA's. In local operation, CW KEY is a logic high level that is sent to the Modulator/Demodulator via J2. PTT is received from the Control Panel and applied to J2-7, while the output from U7 is disabled.

4-19. SDU INTERFACE CCA (see Figure 4-16, and FO-19). The primary function of the SDU Interface CCA is to provide a communication link between the SDU and RT-1444. Its major component is the UART (Universal Asynchronous Receiver/Transmitter) U1 which sends RT status information to the SDU, and responds to signals coming from the SDU during remote operation. The SDU Interface CCA also contains a squelch detect circuit.

a. Remote operation. The UART receives two differential signals from the SDU: R/T CONTROL and R/T CLOCK. R/T CONTROL is a serial data word (SDI) received on connector pins J1-7, and 8. It is converted to parallel data for RT frequency tuning. R/T 1209 CLOCK is received on J1-5, and 6 is used for UART timing for both UART (transmit and receive) operations. In the UART receive operation, whenever a complete serial data word has been received a parallel word is then made available at the R0 thru R7 pins of the UART. This parallel 8-bit data word (B0 thru B7) is used to control the tuning parameters of the RT. These 8 bits, form the control bus, which is sent to the RT Interface CCA via connector P2 pins 5-9 and 17-19. The DATA AVAILABLE (DA) pin of the UART is connected to the input of shift register U2B. Whenever a complete serial data word has been received, DA goes high. It is then inverted by U3 and shifted out to the DATA AVAILABLE RESET# (DAR#) pin, which resets the UART. The two signals DA and DAR# are also sent to the RT Interface CCA via connector P2.

b. RT-1444 Status Monitoring. The UART also functions to provide the SDU with the status of the RT-1444. The UART performs this function by converting parallel status data information (UART inputs T0 thru T7) into an 8-bit serial data word in the UART transmit operation. Bits T0 thru T2, feedback signals from the UART, monitor UART status. Bits T5 thru T7 are tied to ground. Bit T3, the squelch detect signal, comes from the Squelch Indicator circuit. Bit T4, called KEY, is received on P1-12 and indicates the RT Transmit mode status. The UART sends the serial data word (SDO) to the SDU indicating the condition of the RT.

c. Squelch Indicator Circuit. The squelch indicator circuit detects the received voice signals and provides a one bit indicator to the T3 input of the UART. The circuit consists of Quad Amplifier I.C. U5, and operational amplifier U6. The audio signal, RCV AUDIO, is received on connector P1 and passes thru two filter/level-detect circuits and an operational amplifier U6. The function of these circuits is to detect voice signals and produce a squelch indicator bit. Signal (POT WIPER), receive on connector P1-17, determines the minimum detected squelch level.

d. REMOTE SELECT# Signal. The REMOTE SELECT# signal is used to select the RT-1209 Modification Kit circuitry used during remote operation. REMOTE SELECT#, which is a logic low, originates from the SDU and comes in on J1-2. When the SDU is connected to the RT 1209 Modification Kit, the RT is automatically placed in remote operation. The signal comes into the circuit board and is applied simultaneously to the input of inverter U3 and thru connector P1-15 to the Panel Interface CCA and P2-4 to the RT Interface CCA. The output of the inverter is applied to the Panel Interface CCA thru P1-11. If the SDU is not plugged into the Modification Kit, the line is pulled-up to a logic high enabling the RT to be controlled locally.

4-20. RT INTERFACE CCA (see Figure 4-17 and FO-20). The function of the RT Interface CCA is to send frequency and bandwidth select information to the A3 Synthesizer assembly of the RT in both remote and local operations. Two sets of selected information are connected in a "bus" arrangement to the inputs of 4 seven-input "Darlington" buffer/inverters U1, U3, U5, and U7. One set coming from the control panel switches (via the Panel Interface CCA), and the other coming from four dual 4-bit latches U2, U4, U6, and U8.

a. Normal (Local) Operation. In local (non-remote) operation, the inputs to the "Darlington" buffers are supplied by 28 signals received on connectors J3 and J4 from the Panel Interface CCA. These 28 frequency select signals are received from the six Control Panel switches via the SDU Interface CCA (see Technical Manual TM-07748A-45/2 for a description of the Control Panel Frequency KHz Switches). The REMOTE SELECT# line is high causing the 4-bit latch outputs to be in a high impedance condition providing no signal to the "Darlington" inputs.

b. Remote Operation. In remote operation, the inputs to the "Darlington" buffer/inverters are supplied by the four 4-bit latch outputs. The REMOTE SELECT# is low, enabling the signals at the latch outputs to be available to the inputs of the "Darlingtons". The tuning instructions are contained in the parallel data word (B0 thru B7) sent by the SDU Interface CCA and received at connector J1. Bits B0 thru B3 are connected as a data bus to the "D" inputs of the four 4-bit latches, and contain individual frequency tuning and bandwidth select information. Bits B4 thru B7 are connected to the "Data" inputs of latch/decoder U9. These addressing bits, when decoded, select the latch that determines the range of frequencies and bandwidth that will be tuned. These decoded range bits clock the frequency tuning information into the 4-bit latches. The outputs from the "Darlington" buffer/inverters are the RT tuning instructions and are sent to Synthesizer A3 via connector J2. Signals DAR# and DA, sent from the SDU Interface CCA, are received at connector J1 and provide the Strobe and Inhibit inputs for latch/decoder U9.

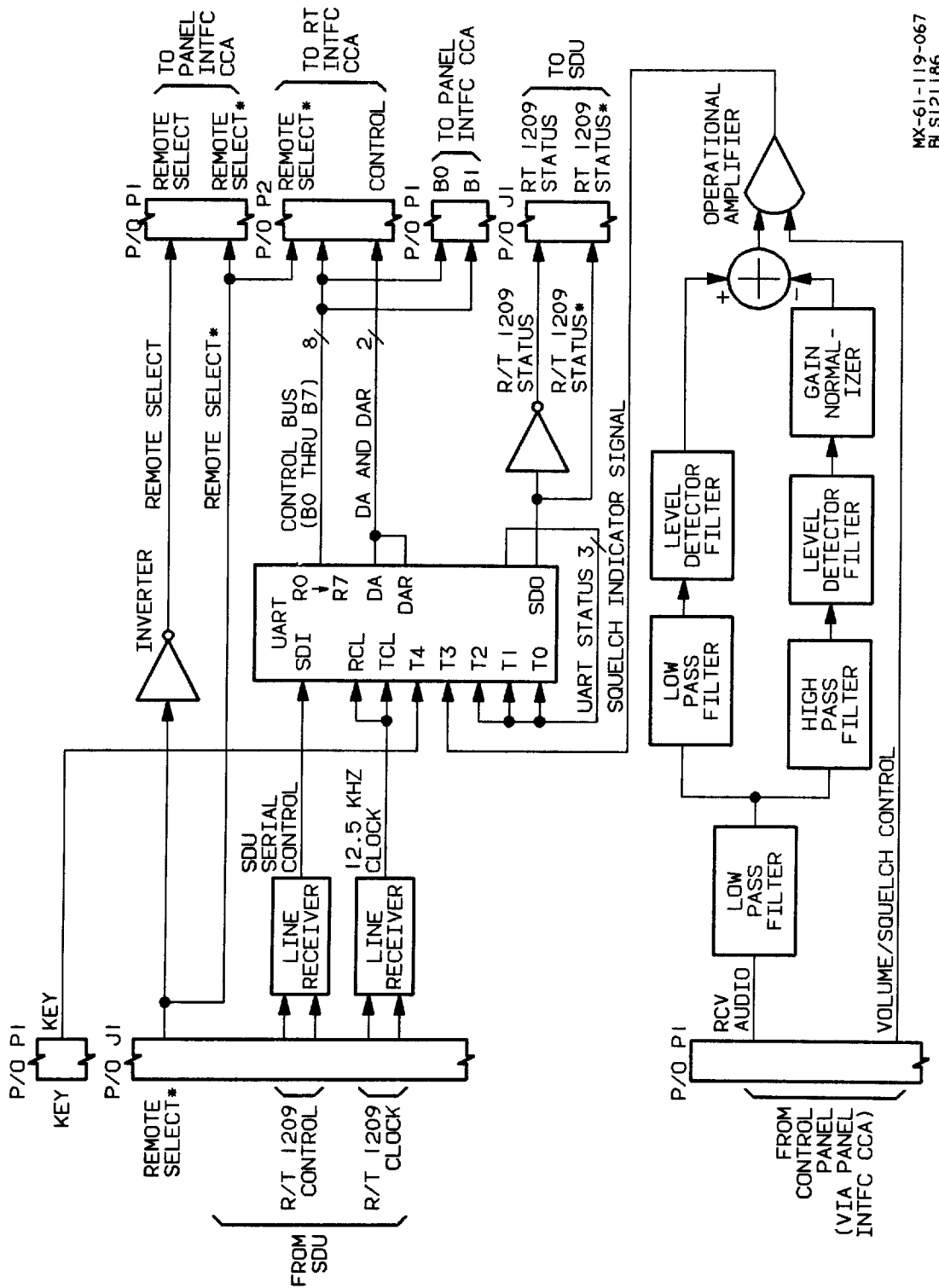

MX-61-119-067  
BLS121186

Figure 4-16. SDU Interface CCA Block Diagram

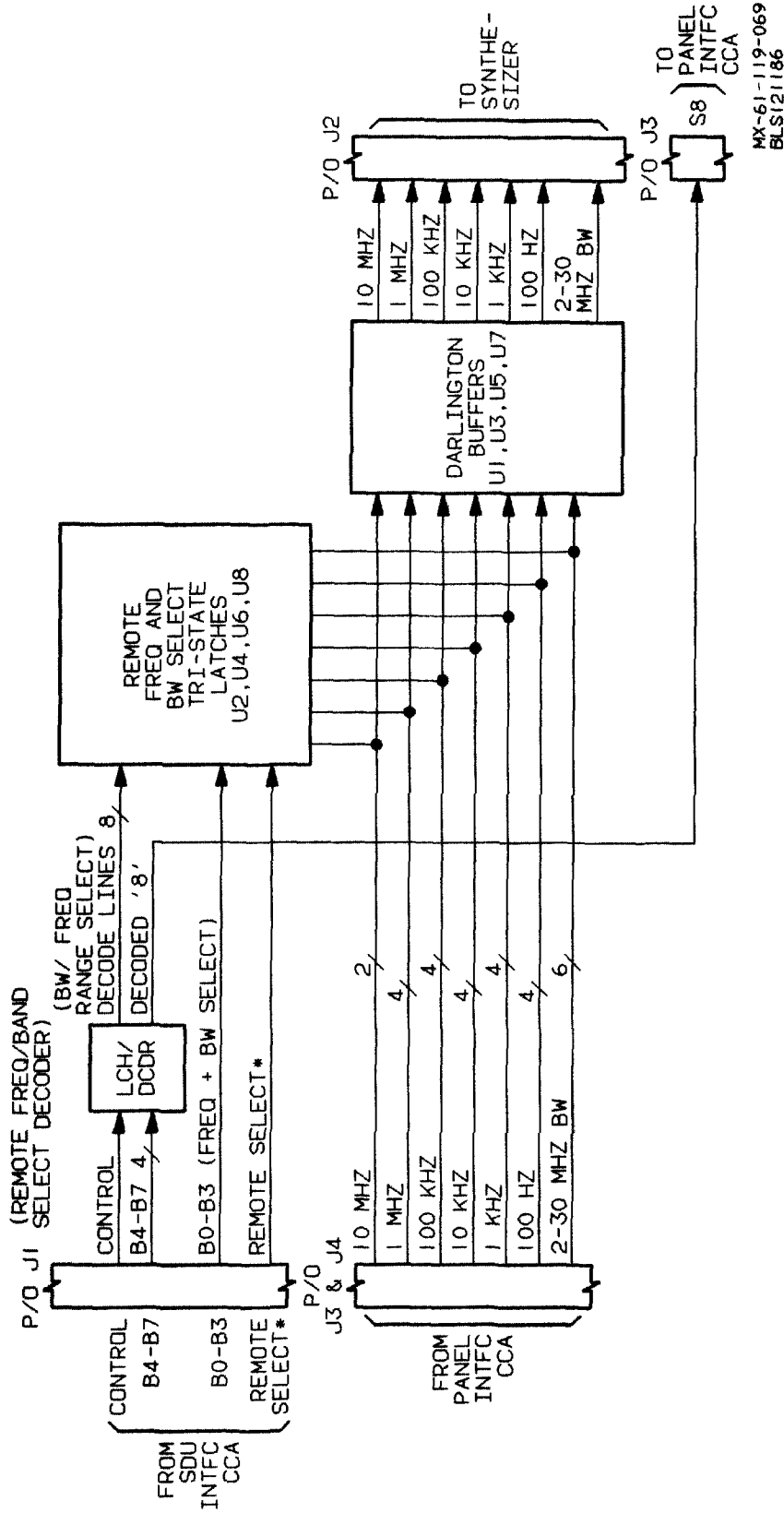

Figure 4-17. RT Interface CCA Block Diagram



## CHAPTER 5

## MAINTENANCE

5-1. SCOPE. This chapter contains information for the maintenance of subassemblies of the Radio System that are authorized to be repaired at the depot. This chapter is divided into two sections: Section I, Special Maintenance; and Section II, Performance Test Checks.

## Section I. SPECIAL MAINTENANCE

5-2. GENERAL. This section contains depot level maintenance instructions for bench testing, troubleshooting, repair, cleaning, and retesting of SRU's to return them to a serviceable condition. All the maintenance steps for each individual SRU are presented together. Refer to the Illustrated Parts Breakdown SMR codes for the disposition of subassemblies and components not repairable. The red and black interface CCA's and the CPU CCA are tested with ATE. The repairable SRU's are as follows:

- a. SDU Electrical Equipment Chassis.
- b. Audio Interface (1).
- c. Audio Interface (2).
- d. SDU Power Supply Subassembly.
- e. Fiber Optic Module Assembly (TBD).
- f. Fiber Optic Transmitter CCA (TBD).
- g. Fiber Optic Receiver CCA (TBD).
- h. Fiber Optic Cable Assembly.
- i. Radio Set Control.
- j. RSC Audio Interface CCA.
- k. RSC Digital Interface CCA.
- l. RSC Regulator CCA.
- m. FM BITE/Audio Interface.
- n. FM BITE/Audio CCA.
- o. Distribution Box.
- p. PDU Electrical Equipment Chassis Maintenance.

## T.O. 31R2-2GRC206-12

### 5-3. SDU ELECTRICAL EQUIPMENT CHASSIS MAINTENANCE.

- a. Bench Test Setup. The bench test setup of the electrical equipment chassis is illustrated in figure 5-1.
- b. Component Performance Test Table. The component performance test table for the electrical equipment chassis is contained in table 5-1. This table is keyed to fault isolation procedures in table 5-2.
- c. Mechanical Assemblies. NOT APPLICABLE.
- d. Cleaning and Lubrication. Clean the electrical equipment chassis of the SDU in accordance with T.O. 00-25-234.

#### NOTE

Prefix component reference designators of the SDU electrical equipment chassis with the number 1.

- e. Repair and Replacement. Repair of the SDU electrical equipment chassis consists of the removal of malfunctioning components and their replacement with serviceable components.

Refer to IPB figure 7-12 for items that are SMR coded for repair at depot level. Upon receipt of an electrical equipment chassis for repair, perform the following procedures as required:

- (1) Loosen screws and remove top and bottom covers.
- (2) Visually inspect the electrical equipment chassis for damaged or broken connectors; bent pins; or broken lens, lamps, or switches. Check for missing screws.
- (3) Replace unserviceable or missing parts.
- (4) Perform all soldering and other electronic maintenance in accordance with T.O. 00-25-234 per MIL-HDBK-454, Requirement 5. Use solder Type SN60WRMAP2 per ANSI-J-STD-006.
- (5) Refer to table 5-3 and FO-13 for electrical wiring connections and sleeving instructions.
- (6) Apply a thin film of grease per MIL-G- 4343 to O-rings of connectors (4 through 11, figure 7-12) prior to installation.
- (7) Apply shrink sleeving M23053/5-204C to solder cups of J3 through J7 after soldering of wire.
- (8) Apply sealant, Grade AV, per MIL-S-22473 to threads of screws (2) prior to installation.

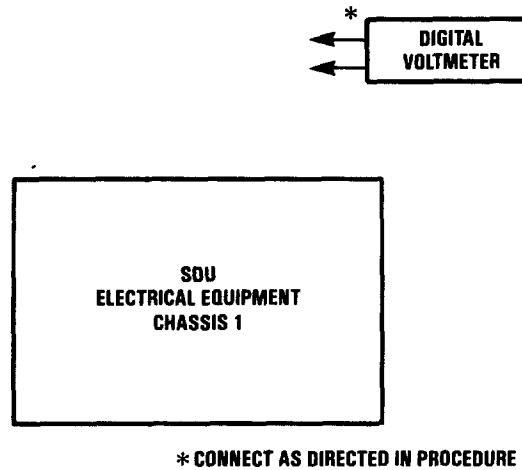

MX-81 118 019

Figure 5-1. SDU Electrical Equipment Chassis 1 Bench Test Setup

f. Reassembly and Testing of Subassemblies and Assemblies. The reassembly instructions for the SDU electrical equipment chassis are provided under its paragraph covering Repair and Replacement.

g. Testing. Perform the instructions contained in table 5-1, SDU Electrical Equipment Chassis Component Performance Tests.

Table 5-1. SDU Electrical Equipment Chassis Component Performance Tests

| Step | Connection of test equipment                   | Point of test | Control settings and operation of equipment   | Performance standard                                    |
|------|--|---------------|---|---|
| 1.   | Connect test equipment as shown in figure 5-1. | Table 5-3     | Visually inspect electrical equipment chassis for physical damage or corrosion.   | No corrosion or damage to electrical equipment chassis. |
| 2.   |  |               |   |   |
| 3.   |  |               | Check for continuity between each point listed.<br><br>Refer to figure 5-1.1 for reference designator locations. Refer to FO-17 for SDU wiring diagram. | Continuity between each point is required.              |

Table 5-2. SDU Electrical Equipment Chassis Fault Isolation Tests

| Step | Procedure   | Normal indication  | Fault location                         |
|------|---|--|--|
| 1.   | Connect equipment as described in table 5-1.<br><br>NOTE<br><br>The two digits after the first hyphen designate the wire gauge. | Continuity between points tested. Refer to FO-17 for SDU wiring diagram. | Replace wiring as listed in table 5-3. |

Table 5-3. SDU Electrical Equipment Chassis Wiring List

| Wire no. | Part no.        | Color   | From  | To           | Remarks                 |
|----------|-----------------|---------|-------|--------------|-------------------------|
| 1        | M22759/11-22-6  | BLUE    | P1-1  | J9-D         | +17.5V                  |
| 2        | M22759/11-24-6  | BLUE    | P1-1  | P2-40        | +17.5V                  |
| 3        | M22759/11-24-0  | BLACK   | P1-2  | P1-6         | GND                     |
| 4        | M22759/11-22-2  | RED     | P1-3  | E3           | +28V                    |
| 5        | M22759/11-18-2  | RED     | E3    | CB1-1 (LOAD) | +28V(FUSED)             |
| 6        | M22759/11-24-0  | BLACK   | P1-6  | P1-12        | GND                     |
| 7        | M22759/11-22-2  | RED     | P1-9  | E3           | +28V                    |
| 8        | M22759/11-22-2  | RED     | E3    | E4           | +28V                    |
| 9        | M22759/11-24-9  | WHITE   | P1-10 | J13-F        | 4 UHF-AM                |
| 10       | M22759/11-24-0  | BLACK   | P1-12 | P1-18        | GND                     |
| 11       | M22759/11-24-3  | ORANGE  | P1-13 | J9-C         | +12V                    |
| 12       | M22759/11-24-3  | ORANGE  | P1-13 | P2-46        | +12V                    |
| 13       | M22759/11-24-1  | BROWN   | P1-14 | J12-M        | DATA LOAD VHF-AM        |
| 14       | M22759/11-24-93 | WHT-ORN | P1-15 | J8-C         | +12V                    |
| 15       | M22759/11-24-4  | YELLOW  | P1-16 | J12-L        | DATA CLOCK VHF-AM       |
| 16       | M22759/11-24-5  | GREEN   | P1-17 | J11-L        | CHANNEL 3               |
| 17       | M22759/11-24-0  | BLACK   | P1-18 | P1-21        | GND                     |
| 18       | M22759/11-24-97 | WHT-VIO | P1-19 | J11-K        | CHANNEL 4               |
| 19       | M22759/11-24-7  | VIOLET  | P1-20 | J11-J        | CHANNEL 5               |
| 20       | M22759/11-24-0  | BLACK   | P1-21 | P1-27        | GND                     |
| 21       | M22759/11-24-8  | GRAY    | P1-22 | J11-E        | CHANNEL 9               |
| 22       | M22759/11-24-90 | WHT-BLK | P1-23 | J11-N        | CHANNEL 1               |
| 23       | M22759/11-24-91 | WHT-BRN | P1-25 | J11-D        | CHANNEL 10              |
| 24       | M22759/11-24-92 | WHT-RED | P1-26 | J11-H        | CHANNEL 6               |
| 25       | M22759/11-24-0  | BLACK   | P1-27 | P1-30        | GND                     |
| 26       | M22759/11-24-93 | WHT-ORN | P1-28 | J11-F        | CHANNEL 8               |
| 27       | M22759/11-24-94 | WHT-YEL | P1-29 | J11-G        | CHANNEL 7               |
| 28       | M22759/11-24-0  | BLACK   | P1-30 | P1-36        | GND                     |
| 29       | M22759/11-24-95 | WHT-GRN | P1-31 | J11-M        | CHANNEL 2               |
| 30       | M22759/11-24-96 | WHT-BLU | P1-32 | J13-H        | 1 UHF-AM                |
| 31       | M22759/11-24-98 | WHT-GRA | P1-34 | J12-S        | SQUELCH IND VHF-AM      |
| 32       | M22759/11-24-6  | BLUE    | P1-35 | J13-G        | 2 UHF-AM                |
| 33       | M22759/11-24-0  | BLACK   | P1-36 | P1-42        | GND                     |
| 34       | M22759/11-24-5  | GREEN   | P1-37 | J12-R        | CLEAR/SECURE IND VHF-AM |
| 35       | M22759/11-24-8  | GRAY    | P1-38 | J13-E        | 8 UHF-AM                |
| 36       | M22759/11-24-9  | WHT-BRN | P1-40 | J12-K        | SERIAL DATA VHF-AM      |
| 37       | M22759/11-24-7  | VIOLET  | P1-41 | J12-D        | DATA AVAIL VHF-AM       |
| 38       | M22759/11-24-0  | BLACK   | P1-42 | P1-48        | GND                     |
| 39       | M22759/11-24-92 | WHT-RED | P1-43 | J12-N        | BITE FAULT VHF-AM       |
| 40       | M22759/11-24-97 | WHT-VIO | P1-44 | J12-U        | PTT VHF-AM              |
| 41       | M22759/11-24-93 | WHT-ORN | P1-46 | J12-T        | PTT IND VHF-AM          |
| 42       | M22759/11-24-9  | WHITE   | P1-47 | J11-Y        | VHF BITE                |
| 43       | M22759/11-22-0  | BLACK   | P1-48 | E2           | GND                     |
| 44       | M22759/11-24-1  | BROWN   | P1-49 | J11-Z        | KY/KY                   |

Table 5-3. SDU Electrical Equipment Chassis Wiring List - Continued

| Wire no. | Part no.        | Color      | From  | To    | Remarks                 |
|----------|-----------------|------------|-------|-------|-------------------------|
| 45       | M22759/11-22-0  | BLACK      | P2-2  | P2-3  | GND                     |
| 46       | M22759/11-22-0  | BLACK      | P2-2  | E1    | GND                     |
| 47       | M22759/11-24-0  | BLACK      | P2-3  | P2-6  | +28V RTN                |
| 48       | M22759/11-24-9  | WHITE      | P2-4  | J12-F | 4 VHF-AM                |
| 49       | M22759/11-24-1  | BROWN      | P2-5  | J13-T | PTT IND UHF-AM          |
| 50       | M22759/11-24-0  | BLACK      | P2-6  | P2-9  | +28V RTN                |
| 51       | M22759/11-24-6  | BLUE       | P2-7  | J12-H | 1 VHF-AM                |
| 52       | M22759/11-24-5  | GREEN      | P2-8  | J13-S | SQUELCH IND UHF-AM      |
| 53       | M22759/11-24-0  | BLACK      | P2-9  | P2-21 | GND                     |
| 54       | M22759/11-24-7  | VIOLET     | P2-10 | J13-U | HQ-PTT UHF-AM           |
| 55       | M22759/11-24-8  | GRAY       | P2-11 | J12-G | 2 VHF-AM                |
| 56       | M22759/11-22-2  | RED        | P2-12 | E4    | +28V                    |
| 57       | M22759/11-24-90 | WHT-BLK    | P2-13 | J12-E | 8 VHF-AM                |
| 58       | M22759/11-24-91 | WHT-BRN    | P2-14 | J13-D | DATA AVAIL UHF-AM       |
| 59       | M22759/11-24-93 | WHT-RED    | P2-16 | J13-L | DATA CLOCK UHF-AM       |
| 60       | M22759/11-24-92 | WHT-ORN    | P2-17 | J13-N | BITE FAULT UHF-AM       |
| 61       | M22759/11-22-21 | RED        | P2-18 | E4    | +28V                    |
| 62       | M22759/11-24-1  | BROWN      | P2-19 | J10-U | POWER AMP BITE          |
| 63       | M22759/11-24-95 | WHT-GRN    | P2-20 | J13-R | CLEAR/SECURE IND UHF-AM |
| 64       | M22759/11-24-0  | BLACK      | P2-21 | P2-27 | GND                     |
| 65       | M22759/11-24-97 | WHT-VIO    | P2-23 | J13-K | SERIAL DATA UHF-AM      |
| 66       | M22759/11-24-96 | WHT-BLU    | P2-25 | J10-T | TIP                     |
| 67       | M22759/11-24-96 | WHT-GRA    | P2-26 | J13-M | DATA LOAD UHF-AM        |
| 68       | M22759/11-24-0  | BLACK      | P2-27 | P2-30 | GND                     |
| 69       | M22759/11-24-4  | YELLOW     | P2-28 | J10-M | RT-1209 CLOCK           |
| 70       | M22759/11-24-0  | BLACK      | P2-30 | P2-36 | GND                     |
| 71       | M22759/11-24-5  | GREEN      | P2-31 | J10-F | RT-1209 CONTROL         |
| 72       | M22759/11-24-7  | VIOLET     | P2-34 | J10-E | RT-1209 CONTROL         |
| 73       | M22759/11-24-0  | BLACK      | P2-36 | P2-42 | GND                     |
| 74       | M22759/11-24-8  | GRAY       | P2-37 | J10-L | RT-1209 CLOCK           |
| 75       | M22759/11-22-6  | BLUE       | P2-40 | J8-D  | +17.5V                  |
| 76       | M22759/11-24-0  | BLACK      | P2-42 | P2-48 | GND                     |
| 78       | M22759/11-24-3  | ORANGE     | P2-46 | J11-X | +12V                    |
| 79       | M22759/11-24-9  | WHITE      | P2-47 | J10-K | RT-1209 STATUS          |
| 80       | M22759/11-24-93 | WHT-ORN    | P2-49 | J10-J | RT-1209 STATUS          |
| 81       | M22759/11-24-1  | BROWN      | P3-18 | J4-B  | IC RCV AUDIO            |
| 82       | 469557-249      | WHT (SHLD) | P3-15 | J4-D  | IC XMT AUDIO            |
| 83       | 469557-243      | ORN (SHLD) | P3-2  | J5-D  | HF-SSB XMT AUDIO        |
| 84       | M22759/11-24-0  | BLACK      | P3-16 | J4-A  | IC AUDIO COMMON         |
| 85       | 469557-244      | YEL (SHLD) | P3-3  | J3-D  | VHF-FM XMT AUDIO        |
| 86       | M22759/11-24-5  | GREEN      | P3-14 | J5-B  | HF-SSB RCV AUDIO        |
| 87       | M22759/11-24-6  | BLUE       | P3-4  | J4-C  | IC KEY                  |
| 88       | M22759/11-24-5  | VIOLET     | P3-1  | J3-B  | VHF-FM RCV AUDIO        |

Table 5-3. SDU Electrical Equipment Chassis Wiring List - Continued

| Wire no. | Part no.        | Color      | From  | To         | Remarks          |
|----------|-----------------|------------|-------|------------|------------------|
| 89       | M22759/11-24-8  | GRAY       | P3-5  | J3-C       | VHF-FM KEY PTT   |
| 90       | M22759/11-24-9  | WHITE      | P3-6  | J5-C       | HF-SSB KEY       |
| 91       | M22759/11-24-2  | RED        | P3-7  | J6-C       | VHF-AM KEY PTT   |
| 92       | M22759/11-24-3  | ORANGE     | P3-21 | J4-E       | A2 XMT KEY       |
| 93       | M22759/11-24-4  | YELLOW     | P3-8  | J7-C       | UHF-AM KEY PTT   |
| 94       | M22759/11-24-90 | WHT-BLK    | P3-22 | J4-F       | A1 XMT KEY       |
| 95       | 469557-245      | GRN (SHLD) | P3-19 | J7-D       | UHF-AM XMT AUDIO |
| 96       | M22759/11-24-0  | BLACK      | P3-26 | J7-A       | GND              |
| 97       | M22759/11-24-91 | WHT-BRN    | P3-20 | J7-B       | UHF-AM RCV AUDIO |
| 98       | M22759/11-24-0  | BLACK      | P3-13 | J3-A       | GND              |
| 99       | M22759/11-24-0  | BLACK      | P3-25 | J5-A       | GND              |
| 100      | 469557-241      | BRN (SHLD) | P3-24 | J6-D       | VHF-AM XMT AUDIO |
| 101      | M22759/11-24-0  | BLACK      | P3-12 | J6-A       | GND              |
| 102      | M22759/11-24-92 | WHT-RED    | P3-23 | J6-B       | VHF-AM RCV AUDIO |
| 103      | M22759/11-24-0  | BLACK      | J3-A  | W85 (SHLD) | GND              |
| 104      | M22759/11-24-0  | BLACK      | J4-A  | W82 (SHLD) | GND              |
| 105      | M22759/11-24-0  | BLACK      | J5-A  | W83 (SHLD) | GND              |
| 106      | M22759/11-24-0  | BLACK      | J6-A  | 100 (SHLD) | GND              |
| 107      | M22759/11-24-0  | BLACK      | J7-A  | 95 (SHLD)  | GND              |
| 108      | M22759/11-24-0  | BLACK      | E1    | J13-P      | GND              |
| 109      | M22759/11-24-0  | BLACK      | E1    | J13-V      | GND              |
| 110      | M22759/11-24-0  | BLACK      | E1    | J13-W      | GND              |
| 111      | M22759/11-24-0  | BLACK      | E1    | J13-Y      | GND              |
| 112      | M22759/11-24-0  | BLACK      | E1    | J13-a      | GND              |
| 113      | M22759/11-22-0  | BLACK      | E1    | J14-C      | GND              |
| 114      | M22759/11-22-0  | BLACK      | E1    | J14-B      | GND              |
| 118      | M22759/11-24-0  | BLACK      | E1    | J10-R      | GND              |
| 119      | M22759/11-24-0  | BLACK      | E1    | J10-V      | GND              |
| 120      | M22769/11-24-0  | BLACK      | E2    | J8-B       | GND              |
| 121      | M22769/11-24-0  | BLACK      | E2    | J9-B       | GND              |
| 122      | M22759/11-24-0  | BLACK      | E2    | J11-A      | GND              |
| 123      | M22759/11-24-0  | BLACK      | E2    | J11-U      | GND              |
| 124      | M22759/11-24-0  | BLACK      | E2    | J11-W      | GND              |
| 125      | M22759/11-24-0  | BLACK      | E2    | J12-P      | GND              |
| 126      | M22759/11-24-0  | BLACK      | E2    | J12-V      | GND              |
| 127      | M22759/11-24-0  | BLACK      | E2    | J12-W      | GND              |
| 128      | M22759/11-24-0  | BLACK      | E2    | J12-X      | GND              |
| 129      | M22759/11-24-0  | BLACK      | E2    | J12-Y      | GND              |
| 130      | M22759/11-24-0  | BLACK      | E2    | J12-a      | GND              |
| 131      | M22759/11-24-0  | BLACK      | E2    | J11-P      | GND              |

Table 5-3. SDU Electrical Equipment Chassis Wiring List - Continued

| Wire no. | Part no.        | Color   | From  | To           | Remarks           |
|----------|-----------------|---------|-------|--------------|-------------------|
| 132      | M22759/11-18-2  | RED     | J14-A | CB1-2 (LINE) | +28V(FUSED)       |
| 133      | M22759/11-24-0  | BLACK   | E1    | J13-J        | SHIELD GND        |
| 134      | M22759/11-24-0  | BLACK   | E2    | J11-C        | GND               |
| 135      | M22759/11-24-98 | WHT-GRA | P1-24 | J11-R        | RT-246 DETECT     |
| 136      | M22759/11-22-2  | RED     | E4    | J8-E         | +28V              |
| 137      | M22759/11-22-2  | RED     | E4    | J9-E         | +28V              |
| 138      | M22759/11-24-2  | RED     | P2-24 | J11-B        | VHF-FM DETECT RTN |
| 139      | M22759/11-22-0  | BLACK   | J8-F  | E2           | GND               |
| 140      | M22759/11-22-0  | BLACK   | J9-F  | E2           | GND               |



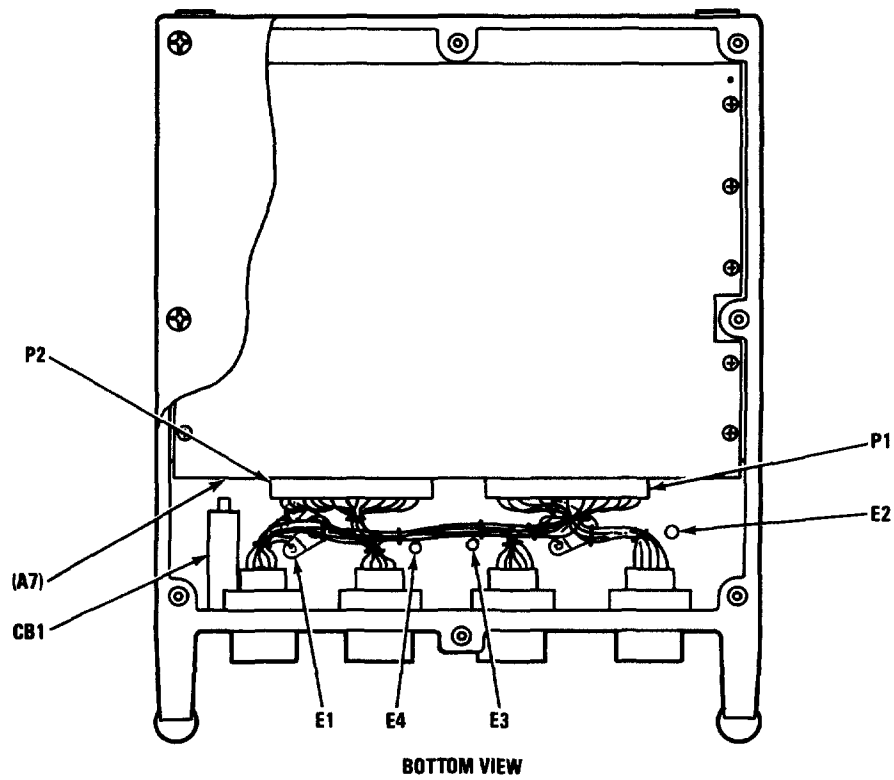

**NOTE: REFERENCE DESIGNATIONS ARE ABBREVIATED.  
PREFIX WITH 1.**

MX-81 118-081  
REF MX DWG 012086

Figure 5-1.1 SDU Reference Designator Location

5-4. AUDIO INTERFACE (1) MAINTENANCE.

- a. Bench Test Setup. The bench test setup of the SDU is illustrated in figure 5-2. The audio interface (1) is included in this bench test setup.

CAUTION

Prior to handling electrostatic-sensitive electronic devices, personnel and equipment must be grounded to prevent static discharge damage to the device. Do not remove or install subassembly in test fixture with power applied or damage to equipment may result.

Do not attempt to install both audio interface circuit cards in the card guides on the test set at the same time, or damage to equipment may result.

NOTE

Subassemblies shipped in nonapproved containers may be subject to multiple failures due to mishandling.

- b. Component Performance Test Table. The component performance test for the audio interface (1) is included in table 5-4. This table is keyed to fault isolation procedures in table 5-5.
- c. Mechanical Assemblies. NOT APPLICABLE
- d. Cleaning and Lubrication.

CAUTION

Prior to handling electrostatic-sensitive electronic devices, personnel and equipment must be grounded to prevent static discharge damage to the device.

NOTE

Prefix component reference designators of the audio interface (1) CCA with 1A1.

Clean the audio interface (1) CCA in accordance with TO 00-25-234.

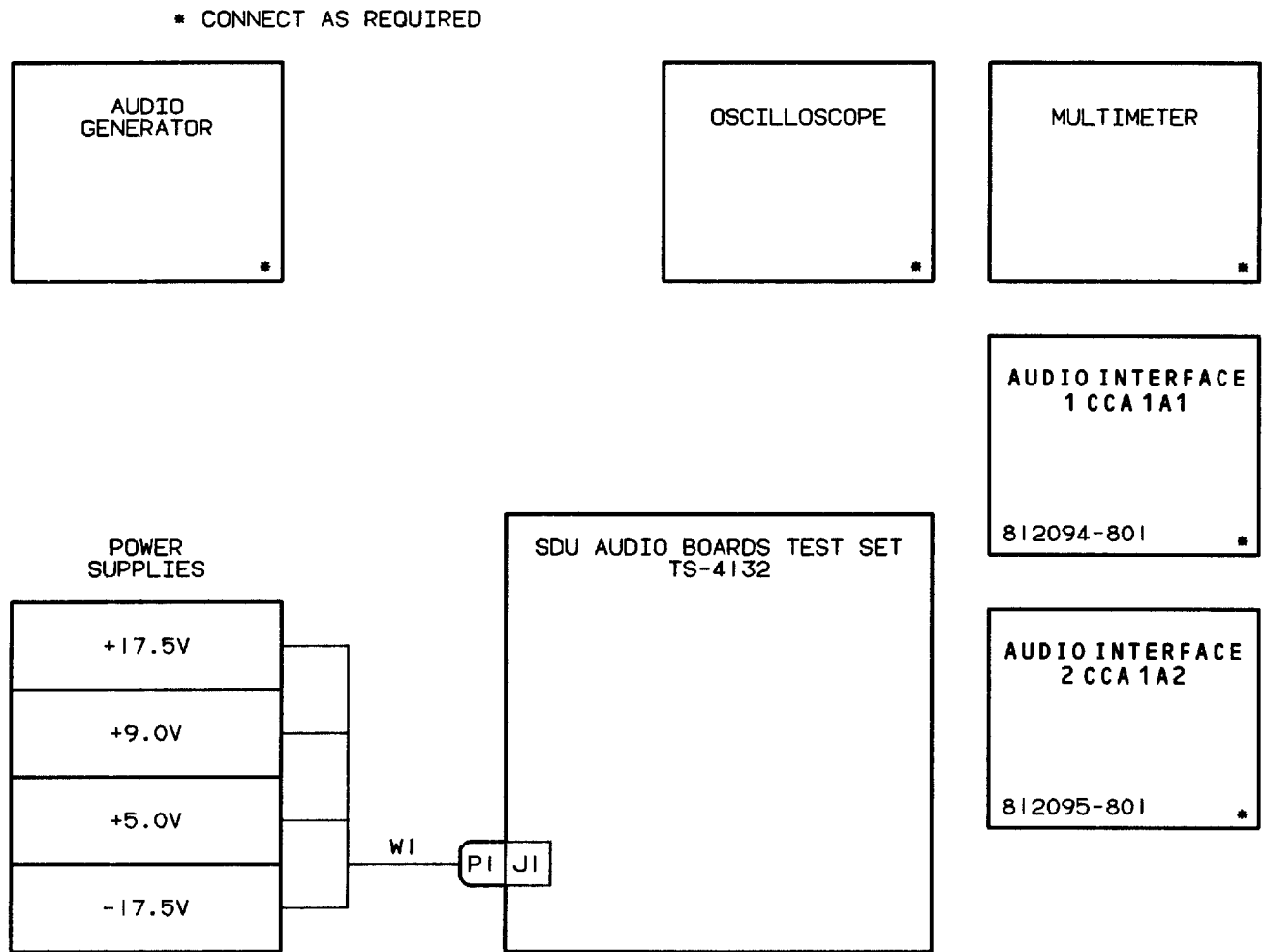

MX-01-118-04

Figure 5-2. SDU CCAs Bench Test Setup.

e. Repair and Replacement. Repair of the audio interface (1) CCA consists of the removal of malfunctioning components and their replacement with serviceable components. Refer to IPB figure 7-4 for items that are SMR coded for repair at depot level. Upon receipt of an audio interface (1) CCA for repair at depot level, perform the following procedures:

CAUTION

Digital microcircuits U3, U6 through U12, U14, U15, U18, U19, U21 through U23, U25, U28, and U29 are susceptible to electrostatic discharge damage. Prior to handling electrostatic-sensitive electronic devices, personnel and equipment must be grounded to prevent static discharge damage to the device.

- (1) Visually inspect CCA for damage to component or traces from heat, deterioration, moisture, or deposits from oxidation or corrosion.
- (2) Check for broken wires, bent pins, frayed insulation, and poor soldering connections.
- (3) Check printed wiring board for cracks or delamination.
- (4) Replace defective components. Refer to figures 5-3 and 7-4 for component location and orientation. Maximum allowable component height of connectors J1 and J3 is 0.47 and 0.40 inches, respectively.
- (5) Perform all soldering and other electronic maintenance in accordance with TO 00-25-234 per MIL-STD-454, Requirement 5. Use solder Type SN60WRMAP2 per QQ-S-571.
- (6) Except for indicated areas in figure 5-3, cover both sides with conformal coating per MIL-I-46058, Type UR.

f. Reassembly and Testing of Subassemblies and Assemblies. Refer to the above paragraph, Repair and Replacement, for special reassembly instructions of the audio interface (1) CCA.

g. Testing. Perform the instructions contained in table 5-4, SDU CCAs Component Performance Tests, to ensure the serviceable condition of the subassembly.

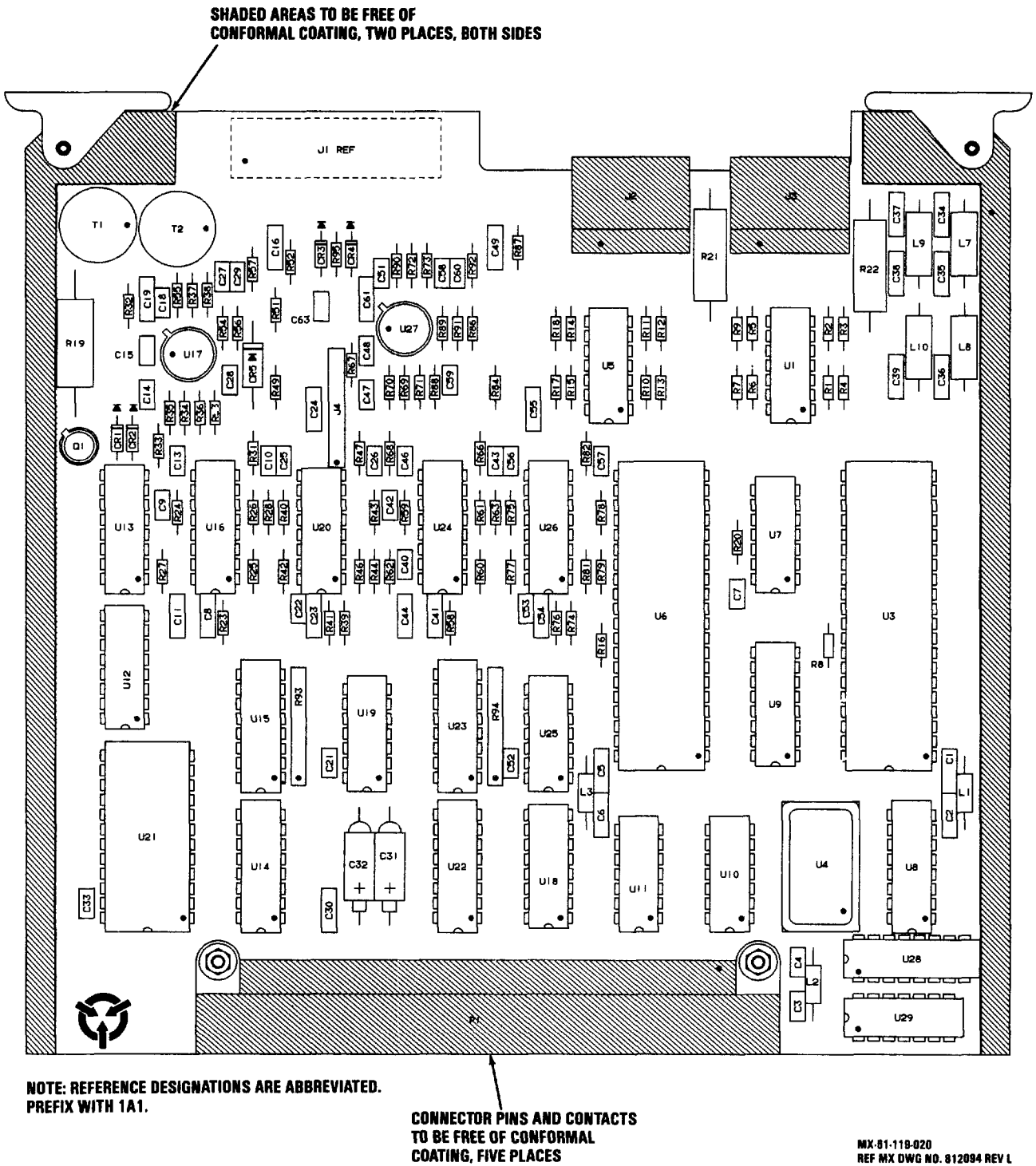

Figure 5-3. Audio Interface (1) 1A1 Component Location

Table 5-4. SDU CCAs Performance Tests

| Step                          | Connection of test equipment   | Point of test | Control settings and operation of equipment   | Performance standard   |
|-------------------------------|--|---------------|---|--|
| <p>1.</p> <p>2.</p> <p>3.</p> | <p>Connect test equipment as shown in Figure 5-2.</p> <p>NOTE</p> <p>When connecting for a negative voltage, connect red to positive and black to negative, as usual. Power cable W1 is wired to produce a negative voltage where needed.</p> <p>Digital multimeter.</p> |               | <p>SETTING-UP PROCEDURE</p> <p>Visually inspect Audio Interface CCA #1 (PN 812094) for visible damage, corrosion, broken or burned components, lifted or broken traces, etc.</p> <p>Turn on power supplies and adjust output.</p> | <p>No visible damage on the board.</p> <p>a. Current limit: between 0.4 and 4.0 amps, short circuit.</p> <p>b. Open circuit output voltages are as follows:</p> <p>(1) +17.5 +/- 0.5 Vdc</p> <p>(2) +9.0 +/- 0.5 Vdc</p> <p>(3) +5.0 +/- 0.5 Vdc</p> <p>(4) -17.5 +/- 0.5 Vdc.</p> |

Table 5-4. SDU CCAs Performance Tests - Continued

| Step           | Connection of test equipment   | Point of test | Control settings and operation of equipment  | Performance standard |                 |    |          |     |        |     |         |     |     |     |   |     |   |    |         |    |          |     |        |  |
|----------------|--|---------------|--|----------------------|-----------------|----|----------|-----|--------|-----|---------|-----|-----|-----|---|-----|---|----|---------|----|----------|-----|--------|--|
| 4.             | Slide Audio Interface CCA #1 P/N 812094 into test panel card guider and mate with J4.                          |               |  |                      |                 |    |          |     |        |     |         |     |     |     |   |     |   |    |         |    |          |     |        |  |
| 5.             | Connect pendant cable connectors P1, P2, and P3 from test fixture into circuit card connectors J1, J2, and J3. |               |  |                      |                 |    |          |     |        |     |         |     |     |     |   |     |   |    |         |    |          |     |        |  |
|                |  |               | <p>NOTE</p> <p>Switches may be in any position until a switch setting is specified. Ignore status of indicators not mentioned.</p>   |                      |                 |    |          |     |        |     |         |     |     |     |   |     |   |    |         |    |          |     |        |  |
| 6.             |  |               | <p>Set switches as follows:</p> <table border="0" style="width: 100%;"> <thead> <tr> <th style="text-align: left;"><u>Control</u></th> <th style="text-align: left;"><u>Position</u></th> </tr> </thead> <tbody> <tr> <td>R1</td> <td>full CCW</td> </tr> <tr> <td>S14</td> <td>MANUAL</td> </tr> <tr> <td>S15</td> <td>BOARD 1</td> </tr> <tr> <td>S16</td> <td>OFF</td> </tr> <tr> <td>S26</td> <td>1</td> </tr> <tr> <td>S27</td> <td>1</td> </tr> <tr> <td>R2</td> <td>full CW</td> </tr> <tr> <td>R3</td> <td>full CCW</td> </tr> <tr> <td>S18</td> <td>VHF-AM</td> </tr> </tbody> </table> | <u>Control</u>       | <u>Position</u> | R1 | full CCW | S14 | MANUAL | S15 | BOARD 1 | S16 | OFF | S26 | 1 | S27 | 1 | R2 | full CW | R3 | full CCW | S18 | VHF-AM |  |
| <u>Control</u> | <u>Position</u>  |               |  |                      |                 |    |          |     |        |     |         |     |     |     |   |     |   |    |         |    |          |     |        |  |
| R1             | full CCW   |               |  |                      |                 |    |          |     |        |     |         |     |     |     |   |     |   |    |         |    |          |     |        |  |
| S14            | MANUAL   |               |  |                      |                 |    |          |     |        |     |         |     |     |     |   |     |   |    |         |    |          |     |        |  |
| S15            | BOARD 1  |               |  |                      |                 |    |          |     |        |     |         |     |     |     |   |     |   |    |         |    |          |     |        |  |
| S16            | OFF  |               |  |                      |                 |    |          |     |        |     |         |     |     |     |   |     |   |    |         |    |          |     |        |  |
| S26            | 1  |               |  |                      |                 |    |          |     |        |     |         |     |     |     |   |     |   |    |         |    |          |     |        |  |
| S27            | 1  |               |  |                      |                 |    |          |     |        |     |         |     |     |     |   |     |   |    |         |    |          |     |        |  |
| R2             | full CW  |               |  |                      |                 |    |          |     |        |     |         |     |     |     |   |     |   |    |         |    |          |     |        |  |
| R3             | full CCW   |               |  |                      |                 |    |          |     |        |     |         |     |     |     |   |     |   |    |         |    |          |     |        |  |
| S18            | VHF-AM   |               |  |                      |                 |    |          |     |        |     |         |     |     |     |   |     |   |    |         |    |          |     |        |  |

Table 5-4. SDU CCAs Performance Tests - Continued

| Step        | Connection of test equipment | Point of test | Control settings and operation of equipment  | Performance standard  |           |     |     |     |     |     |     |     |     |   |
|-------------|------------------------------|---------------|--|---|-----------|-----|-----|-----|-----|-----|-----|-----|-----|---|
| 6.<br>cont. |                              |               | <p>S19            VHF-AM<br/>                     S20            VHF-AM<br/>                     S2             STD DECODE<br/>                     S5             LOGIC 1<br/>                     S6             LOGIC 1<br/>                     S7             LOGIC 1<br/>                     S8             LOGIC 1<br/>                     S9             LOGIC 0<br/>                     S10            LOGIC 0</p> <p style="text-align: center;">NOTE</p> <p>S35 is located on top of test set, on card guide.</p> <p>S35            NORMAL</p> |   |           |     |     |     |     |     |     |     |     |   |
| 7.          |                              |               | <p>Apply 10.0 +/- 0.4 V p-p @ 600 +/- 60 Hz to J2 and J3, under load.</p>  |   |           |     |     |     |     |     |     |     |     |   |
|             |                              |               | POWER AND CIRCUIT TESTS  |   |           |     |     |     |     |     |     |     |     |   |
| 8.          |                              |               | <p>Readjust power supply voltages while monitoring the respective test points:</p>   |   |           |     |     |     |     |     |     |     |     |   |
|             |                              |               | Turn S1 ON.  | CR1, CR2, CR3, CR4 lighted.                                 |           |     |     |     |     |     |     |     |     |   |
|             |                              |               | <table border="0"> <thead> <tr> <th style="text-align: left;"><u>From</u></th> <th style="text-align: left;"><u>To</u></th> </tr> </thead> <tbody> <tr> <td>TP1</td> <td>TP7</td> </tr> <tr> <td>TP2</td> <td>TP7</td> </tr> <tr> <td>TP3</td> <td>TP7</td> </tr> <tr> <td>TP4</td> <td>TP7</td> </tr> </tbody> </table>   | <u>From</u>   | <u>To</u> | TP1 | TP7 | TP2 | TP7 | TP3 | TP7 | TP4 | TP7 | <p>+17.5 +/- 0.5 Vdc<br/>                     +9.0 +/- 0.5 Vdc<br/>                     +5.0 +/- 0.5 Vdc<br/>                     -17.5 +/- 0.5 Vdc</p> |
| <u>From</u> | <u>To</u>                    |               |  |   |           |     |     |     |     |     |     |     |     |   |
| TP1         | TP7                          |               |  |   |           |     |     |     |     |     |     |     |     |   |
| TP2         | TP7                          |               |  |   |           |     |     |     |     |     |     |     |     |   |
| TP3         | TP7                          |               |  |   |           |     |     |     |     |     |     |     |     |   |
| TP4         | TP7                          |               |  |   |           |     |     |     |     |     |     |     |     |   |
| 9.          |                              |               | <p>Press and hold S22.<br/>                     Release S22.</p>   | <p>CR14 lights.<br/>                     CR14 goes out.</p> |           |     |     |     |     |     |     |     |     |   |
| 10.         |                              |               | <p>Press and hold S23.<br/>                     Release S23.</p>   | <p>CR15 lights.<br/>                     CR15 goes out.</p> |           |     |     |     |     |     |     |     |     |   |



Table 5-4. SDU CCAs Performance Tests - Continued

| Step | Connection of test equipment | Point of test | Control settings and operation of equipment                               | Performance standard                               |
|------|------------------------------|---------------|---|--|
| 11.  |                              |               | Press and hold S24.<br>Release S24.                                       | CR16 lights.<br>CR16 goes out.                     |
| 12.  |                              |               | Set and hold S25 in A1 position.<br>Release S25.                          | CR17 goes out.<br>CR17 lights.                     |
| 13.  |                              |               | Place S25 in A2 position.<br>Release S25.                                 | CR17 goes out.<br>CR17 lights.                     |
|      | Oscilloscope.                |               | NOTE<br>Ensure audio generator output is still 10 V p-p loaded.           |  |
|      |                              |               | VHF-AM CIRCUIT TESTS  |  |
| 14.  | Test set.                    |               | Press S30.<br>Adjust R1 for convenient hearing.                           | 600 Hz tone from LS1.                              |
| 15.  | Oscilloscope.                |               | Set S2 to UHF-AM.<br>Monitor signal between TP8 and GND TP9 (STD DECODE). | 5.2 +/- 0.7 V p-p,<br>CR18 not lighted.            |
| 16.  |                              |               | Set S8 to LOGIC 0.<br>Press S30.  | CR18 lights.                                       |
| 17.  |                              |               | Set S7 to LOGIC 0.<br>Press S30.  | Audio present at TP8.<br>Audio not present at TP8. |
|      |                              |               | UHF-AM CIRCUIT TESTS  |  |
|      |                              |               | NOTE<br>Verify audio generator output is still 10 V p-p loaded.           |  |

Table 5-4. SDU CCAs Performance Tests - Continued

| Step                             | Connection of test equipment | Point of test | Control settings and operation of equipment  | Performance standard   |             |           |      |
|----------------------------------|------------------------------|---------------|--|--|-------------|-----------|------|
| 18.                              | Test set.                    |               | Set S7 to LOGIC 1.<br>Press S29.   | CR19 lights when S29 is pressed.   |             |           |      |
| 19.                              |                              |               | Set S18, S19, and S20 to UHF-AM.   | CR19 not lighted.  |             |           |      |
| 20.                              | Oscilloscope.                |               | Set S8 to LOGIC 1.<br>Press S29.   | 600 Hz tone from LS1.  |             |           |      |
| 21.                              |                              |               | Set S2 to STD DECODE.  | 600 Hz tone from LS1.  |             |           |      |
|                                  |                              |               | Set S7 to LOGIC 0.<br>Press S29.   | Audio present at TP8.<br>Audio not present at TP8.<br>600 Hz Audio tone absent from LS1. |             |           |      |
| TEST SET A/D CONVERSION TEST     |                              |               |  |  |             |           |      |
| 22.                              | Test set.                    |               | Set S20 to STD ENCODE.<br>Set S8 to LOGIC 0.<br>Press S29.   | CR19 lights when S29 is pressed.   |             |           |      |
| 23.                              |                              |               | Apply 5.0 +/- 0.2 V p-p @ 600 +/- 60 Hz to J2 and J3 under load.   |  |             |           |      |
| UHF-AM D/A AND PTT CIRCUIT CHECK |                              |               |  |  |             |           |      |
| 24.                              | Oscilloscope.                |               | Set S2 to VHF-AM.<br>Check signal:   | 0.10 +/- 0.02 V p-p.   |             |           |      |
| 25.                              |                              |               | <table border="0" style="width: 100%;"> <tr> <td style="text-align: center;"><u>From</u></td> <td style="text-align: center;"><u>To</u></td> </tr> <tr> <td style="text-align: center;">TP18</td> <td style="text-align: center;">TP21</td> </tr> </table> |  | <u>From</u> | <u>To</u> | TP18 |
| <u>From</u>                      | <u>To</u>                    |               |  |  |             |           |      |
| TP18                             | TP21                         |               |  |  |             |           |      |

Table 5-4. SDU CCAs Performance Tests - Continued

| Step        | Connection of test equipment | Point of test | Control settings and operation of equipment  | Performance standard                      |           |      |      |                      |
|-------------|------------------------------|---------------|--|---|-----------|------|------|----------------------|
| 26.         |                              |               | Set S8 to LOGIC 0.<br>Press S29.   | Audio present at TP18.                    |           |      |      |                      |
| 27.         |                              |               | Set S10 to LOGIC 1.<br>Press S29.  | Audio not present at TP18.                |           |      |      |                      |
| 28.         |                              |               | Set S10 to LOGIC 0.<br>Press S29.  | Audio present at TP18.                    |           |      |      |                      |
|             |                              |               | NOTE<br><br>Ensure audio generator output is 5 V p-p, under load.  |   |           |      |      |                      |
|             |                              |               | VHF-AM PTT CIRCUIT CHECKS  |   |           |      |      |                      |
| 29.         | Test set.                    |               | Set S18 and S19 to VHF-AM.<br>Press S30.<br>Set S2 to IC position.<br>Check signal:  | 600 Hz tone from LS1.                     |           |      |      |                      |
|             | Oscilloscope.                |               | <table border="0" style="width: 100%;"> <tr> <td style="text-align: center;"><u>From</u></td> <td style="text-align: center;"><u>To</u></td> </tr> <tr> <td style="text-align: center;">TP19</td> <td style="text-align: center;">TP21</td> </tr> </table> | <u>From</u>                               | <u>To</u> | TP19 | TP21 | 0.10 +/- 0.02 V p-p. |
| <u>From</u> | <u>To</u>                    |               |  |   |           |      |      |                      |
| TP19        | TP21                         |               |  |   |           |      |      |                      |
| 30.         |                              |               | Set S8 to LOGIC 1.<br>Press S30.   | Audio not present at TP19. CR18 goes out. |           |      |      |                      |
|             |                              |               | Set S8 to LOGIC 0.<br>Press S30.   | Audio present at TP19. CR18 lights.       |           |      |      |                      |
|             |                              |               | Set S10 to LOGIC 1.<br>Press S30.  | Audio not present at TP19.                |           |      |      |                      |
|             |                              |               | Set S10 to LOGIC 0.<br>Press S30.  | Audio present at TP19.                    |           |      |      |                      |

Table 5-4. SDU CCAs Performance Tests - Continued

| Step                          | Connection of test equipment   | Point of test | Control settings and operation of equipment  | Performance standard            |           |      |      |      |      |      |      |      |      |      |      |      |      |  |
|-------------------------------|--|---------------|--|---------------------------------|-----------|------|------|------|------|------|------|------|------|------|------|------|------|--|
| TIMING CIRCUIT CHECKS         |  |               |  |                                 |           |      |      |      |      |      |      |      |      |      |      |      |      |  |
| 31.                           | Set up oscilloscope to check for wave forms and frequencies.                                     |               | <p data-bbox="748 579 821 606" style="text-align: center;">NOTE</p> <p data-bbox="589 642 992 699">TP70 is located on top of test set, on card guide.</p> <table border="0" data-bbox="589 737 932 982"> <thead> <tr> <th data-bbox="589 737 662 764" style="text-align: left;"><u>From</u></th> <th data-bbox="857 737 899 764" style="text-align: left;"><u>To</u></th> </tr> </thead> <tbody> <tr> <td data-bbox="589 795 662 823">TP24</td> <td data-bbox="857 795 932 823">TP70</td> </tr> <tr> <td data-bbox="589 827 662 854">TP25</td> <td data-bbox="857 827 932 854">TP70</td> </tr> <tr> <td data-bbox="589 858 662 886">TP28</td> <td data-bbox="857 858 932 886">TP70</td> </tr> <tr> <td data-bbox="589 890 662 917">TP26</td> <td data-bbox="857 890 932 917">TP70</td> </tr> <tr> <td data-bbox="589 921 662 949">TP27</td> <td data-bbox="857 921 932 949">TP70</td> </tr> <tr> <td data-bbox="589 953 662 980">TP37</td> <td data-bbox="857 953 932 980">TP70</td> </tr> </tbody> </table> | <u>From</u>                     | <u>To</u> | TP24 | TP70 | TP25 | TP70 | TP28 | TP70 | TP26 | TP70 | TP27 | TP70 | TP37 | TP70 | <p data-bbox="1011 579 1424 699">Logic 0 volts, <math>\leq 0.5</math>.<br/>                     Logic 1 volts, <math>\geq</math> TP2 volts -0.5 V (i.e., 9.0 VDC - 0.5 VDC = 8.5 VDC).</p> <p data-bbox="1011 795 1235 982">25 kHz +/- 7%<br/>                     25 kHz +/- 7%<br/>                     25 kHz +/- 7%<br/>                     50 kHz +/- 7%<br/>                     50 kHz +/- 7%<br/>                     50 kHz +/- 7%</p> |
| <u>From</u>                   | <u>To</u>  |               |  |                                 |           |      |      |      |      |      |      |      |      |      |      |      |      |  |
| TP24                          | TP70   |               |  |                                 |           |      |      |      |      |      |      |      |      |      |      |      |      |  |
| TP25                          | TP70   |               |  |                                 |           |      |      |      |      |      |      |      |      |      |      |      |      |  |
| TP28                          | TP70   |               |  |                                 |           |      |      |      |      |      |      |      |      |      |      |      |      |  |
| TP26                          | TP70   |               |  |                                 |           |      |      |      |      |      |      |      |      |      |      |      |      |  |
| TP27                          | TP70   |               |  |                                 |           |      |      |      |      |      |      |      |      |      |      |      |      |  |
| TP37                          | TP70   |               |  |                                 |           |      |      |      |      |      |      |      |      |      |      |      |      |  |
| END OF CCA #1 TEST PROCEDURES |  |               |  |                                 |           |      |      |      |      |      |      |      |      |      |      |      |      |  |
| 32.                           |  |               | Turn S1 OFF.   |                                 |           |      |      |      |      |      |      |      |      |      |      |      |      |  |
| 33.                           | Disconnect P1, P2, and P3 from circuit card mated to J4 of test set. Remove circuit card CCA #1. |               |  |                                 |           |      |      |      |      |      |      |      |      |      |      |      |      |  |
| CCA #2 TEST SET-UP            |  |               |  |                                 |           |      |      |      |      |      |      |      |      |      |      |      |      |  |
| 34.                           |  |               | Visually inspect Audio Interface CCA #2 (PN 812095) for visible damage, corrosion, broken or burned components, lifted or broken traces, etc.  | No visible damage on the board. |           |      |      |      |      |      |      |      |      |      |      |      |      |  |

Table 5-4. SDU CCAs Performance Tests - Continued

| Step           | Connection of test equipment   | Point of test | Control settings and operation of equipment  | Performance standard |                 |     |         |     |            |     |     |             |     |      |            |     |         |            |         |    |         |    |         |    |         |    |         |    |         |     |         |  |
|----------------|--|---------------|--|----------------------|-----------------|-----|---------|-----|------------|-----|-----|-------------|-----|------|------------|-----|---------|------------|---------|----|---------|----|---------|----|---------|----|---------|----|---------|-----|---------|--|
| 35.            | Slide Audio Interface CCA #2 into test panel card guides and mate with J5. |               |  |                      |                 |     |         |     |            |     |     |             |     |      |            |     |         |            |         |    |         |    |         |    |         |    |         |    |         |     |         |  |
| 36.            | Oscilloscope.  |               | Apply 5.0 +/- 0.2 V p-p @ 600 +/- 60 Hz to J2 and J3 under load.   |                      |                 |     |         |     |            |     |     |             |     |      |            |     |         |            |         |    |         |    |         |    |         |    |         |    |         |     |         |  |
| 37.            |  |               | Turn S1 ON.  |                      |                 |     |         |     |            |     |     |             |     |      |            |     |         |            |         |    |         |    |         |    |         |    |         |    |         |     |         |  |
| 38.            | DMM.   |               | Check for the following DC voltages:   |                      |                 |     |         |     |            |     |     |             |     |      |            |     |         |            |         |    |         |    |         |    |         |    |         |    |         |     |         |  |
|                |  |               | <table border="0"> <thead> <tr> <th><u>From</u></th> <th><u>To</u></th> <th></th> </tr> </thead> <tbody> <tr> <td>TP1</td> <td>TP5</td> <td>5 mV max.</td> </tr> <tr> <td>TP2</td> <td>TP6</td> <td>0.22 V max.</td> </tr> <tr> <td>TP6</td> <td>TP58</td> <td>1.1 V max.</td> </tr> <tr> <td>TP5</td> <td>TP59</td> <td>0.1 V max.</td> </tr> </tbody> </table>   | <u>From</u>          | <u>To</u>       |     | TP1     | TP5 | 5 mV max.  | TP2 | TP6 | 0.22 V max. | TP6 | TP58 | 1.1 V max. | TP5 | TP59    | 0.1 V max. |         |    |         |    |         |    |         |    |         |    |         |     |         |  |
| <u>From</u>    | <u>To</u>  |               |  |                      |                 |     |         |     |            |     |     |             |     |      |            |     |         |            |         |    |         |    |         |    |         |    |         |    |         |     |         |  |
| TP1            | TP5  | 5 mV max.     |  |                      |                 |     |         |     |            |     |     |             |     |      |            |     |         |            |         |    |         |    |         |    |         |    |         |    |         |     |         |  |
| TP2            | TP6  | 0.22 V max.   |  |                      |                 |     |         |     |            |     |     |             |     |      |            |     |         |            |         |    |         |    |         |    |         |    |         |    |         |     |         |  |
| TP6            | TP58   | 1.1 V max.    |  |                      |                 |     |         |     |            |     |     |             |     |      |            |     |         |            |         |    |         |    |         |    |         |    |         |    |         |     |         |  |
| TP5            | TP59   | 0.1 V max.    |  |                      |                 |     |         |     |            |     |     |             |     |      |            |     |         |            |         |    |         |    |         |    |         |    |         |    |         |     |         |  |
| 39.            | Test set.  |               | Set switches as follows:   |                      |                 |     |         |     |            |     |     |             |     |      |            |     |         |            |         |    |         |    |         |    |         |    |         |    |         |     |         |  |
|                |  |               | <table border="0"> <thead> <tr> <th><u>Control</u></th> <th><u>Position</u></th> </tr> </thead> <tbody> <tr> <td>S15</td> <td>BOARD 2</td> </tr> <tr> <td>S31</td> <td>STD ENCODE</td> </tr> <tr> <td>S32</td> <td>IC</td> </tr> <tr> <td>S33</td> <td>IC</td> </tr> <tr> <td>S34</td> <td>2</td> </tr> <tr> <td>S3</td> <td>LOGIC 1</td> </tr> <tr> <td>S4</td> <td>LOGIC 1</td> </tr> <tr> <td>S5</td> <td>LOGIC 1</td> </tr> <tr> <td>S6</td> <td>LOGIC 1</td> </tr> <tr> <td>S7</td> <td>LOGIC 1</td> </tr> <tr> <td>S8</td> <td>LOGIC 1</td> </tr> <tr> <td>S9</td> <td>LOGIC 1</td> </tr> <tr> <td>S10</td> <td>LOGIC 1</td> </tr> </tbody> </table> | <u>Control</u>       | <u>Position</u> | S15 | BOARD 2 | S31 | STD ENCODE | S32 | IC  | S33         | IC  | S34  | 2          | S3  | LOGIC 1 | S4         | LOGIC 1 | S5 | LOGIC 1 | S6 | LOGIC 1 | S7 | LOGIC 1 | S8 | LOGIC 1 | S9 | LOGIC 1 | S10 | LOGIC 1 |  |
| <u>Control</u> | <u>Position</u>  |               |  |                      |                 |     |         |     |            |     |     |             |     |      |            |     |         |            |         |    |         |    |         |    |         |    |         |    |         |     |         |  |
| S15            | BOARD 2  |               |  |                      |                 |     |         |     |            |     |     |             |     |      |            |     |         |            |         |    |         |    |         |    |         |    |         |    |         |     |         |  |
| S31            | STD ENCODE   |               |  |                      |                 |     |         |     |            |     |     |             |     |      |            |     |         |            |         |    |         |    |         |    |         |    |         |    |         |     |         |  |
| S32            | IC   |               |  |                      |                 |     |         |     |            |     |     |             |     |      |            |     |         |            |         |    |         |    |         |    |         |    |         |    |         |     |         |  |
| S33            | IC   |               |  |                      |                 |     |         |     |            |     |     |             |     |      |            |     |         |            |         |    |         |    |         |    |         |    |         |    |         |     |         |  |
| S34            | 2  |               |  |                      |                 |     |         |     |            |     |     |             |     |      |            |     |         |            |         |    |         |    |         |    |         |    |         |    |         |     |         |  |
| S3             | LOGIC 1  |               |  |                      |                 |     |         |     |            |     |     |             |     |      |            |     |         |            |         |    |         |    |         |    |         |    |         |    |         |     |         |  |
| S4             | LOGIC 1  |               |  |                      |                 |     |         |     |            |     |     |             |     |      |            |     |         |            |         |    |         |    |         |    |         |    |         |    |         |     |         |  |
| S5             | LOGIC 1  |               |  |                      |                 |     |         |     |            |     |     |             |     |      |            |     |         |            |         |    |         |    |         |    |         |    |         |    |         |     |         |  |
| S6             | LOGIC 1  |               |  |                      |                 |     |         |     |            |     |     |             |     |      |            |     |         |            |         |    |         |    |         |    |         |    |         |    |         |     |         |  |
| S7             | LOGIC 1  |               |  |                      |                 |     |         |     |            |     |     |             |     |      |            |     |         |            |         |    |         |    |         |    |         |    |         |    |         |     |         |  |
| S8             | LOGIC 1  |               |  |                      |                 |     |         |     |            |     |     |             |     |      |            |     |         |            |         |    |         |    |         |    |         |    |         |    |         |     |         |  |
| S9             | LOGIC 1  |               |  |                      |                 |     |         |     |            |     |     |             |     |      |            |     |         |            |         |    |         |    |         |    |         |    |         |    |         |     |         |  |
| S10            | LOGIC 1  |               |  |                      |                 |     |         |     |            |     |     |             |     |      |            |     |         |            |         |    |         |    |         |    |         |    |         |    |         |     |         |  |
|                |  |               | Press S17.   |                      |                 |     |         |     |            |     |     |             |     |      |            |     |         |            |         |    |         |    |         |    |         |    |         |    |         |     |         |  |

Table 5-4. SDU CCAs Performance Tests - Continued

| Step           | Connection of test equipment  | Point of test | Control settings and operation of equipment  | Performance standard |                 |      |         |                     |         |    |         |    |         |    |         |                       |
|----------------|---|---------------|--|----------------------|-----------------|------|---------|---------------------|---------|----|---------|----|---------|----|---------|-----------------------|
| 39. cont.      | Oscilloscope.   |               | <p style="text-align: center;">NOTE</p> <p>Ensure audio generator output is still 5.0 +/- 0.2 V p-p, loaded.</p>   |                      |                 |      |         |                     |         |    |         |    |         |    |         |                       |
| 40.            | Test set.   |               | <p style="text-align: center;">INTERCOM D/A CIRCUIT TEST</p> <p>Set the following switches in the order listed:</p> <table border="1" style="width: 100%; border-collapse: collapse;"> <thead> <tr> <th style="text-align: left;"><u>Control</u></th> <th style="text-align: left;"><u>Position</u></th> </tr> </thead> <tbody> <tr> <td>S10</td> <td>LOGIC 0</td> </tr> <tr> <td>S9</td> <td>LOGIC 0</td> </tr> <tr> <td>S6</td> <td>LOGIC 0</td> </tr> <tr> <td>S5</td> <td>LOGIC 0</td> </tr> <tr> <td>S3</td> <td>LOGIC 0</td> </tr> </tbody> </table> | <u>Control</u>       | <u>Position</u> | S10  | LOGIC 0 | S9                  | LOGIC 0 | S6 | LOGIC 0 | S5 | LOGIC 0 | S3 | LOGIC 0 | 600 Hz tone from LS1. |
| <u>Control</u> | <u>Position</u>   |               |  |                      |                 |      |         |                     |         |    |         |    |         |    |         |                       |
| S10            | LOGIC 0   |               |  |                      |                 |      |         |                     |         |    |         |    |         |    |         |                       |
| S9             | LOGIC 0   |               |  |                      |                 |      |         |                     |         |    |         |    |         |    |         |                       |
| S6             | LOGIC 0   |               |  |                      |                 |      |         |                     |         |    |         |    |         |    |         |                       |
| S5             | LOGIC 0   |               |  |                      |                 |      |         |                     |         |    |         |    |         |    |         |                       |
| S3             | LOGIC 0   |               |  |                      |                 |      |         |                     |         |    |         |    |         |    |         |                       |
| 41.            | Oscilloscope.<br><br>Connect oscilloscope to measure time lag between zero crossings of input and output signals. |               | <p>Set S2 to STD DECODE.<br/>Check voltage:</p> <table border="1" style="width: 100%; border-collapse: collapse;"> <thead> <tr> <th style="text-align: left;"><u>From</u></th> <th style="text-align: left;"><u>To</u></th> </tr> </thead> <tbody> <tr> <td>TP63</td> <td>TP67</td> </tr> </tbody> </table> <p style="text-align: center;">INTERCOM CIRCUIT TESTS</p>  | <u>From</u>          | <u>To</u>       | TP63 | TP67    | 10.0 +/- 1.1 V p-p. |         |    |         |    |         |    |         |                       |
| <u>From</u>    | <u>To</u>   |               |  |                      |                 |      |         |                     |         |    |         |    |         |    |         |                       |
| TP63           | TP67  |               |  |                      |                 |      |         |                     |         |    |         |    |         |    |         |                       |

Table 5-4. SDU GCAs Performance Tests - Continued

| Step         | Connection of test equipment               | Point of test | Control settings and operation of equipment                       |                                 | Performance standard  |
|--------------|--|---------------|---|---------------------------------|---|
| 41.<br>cont. | Time reference.<br><br>Measured reference. |               | <u>From</u><br><br>J2<br><br>TP63                                 | <u>To</u><br><br>J3<br><br>TP67 | 100 +/- 30 microseconds.<br>CR22 lighted.<br>CR23 lighted.<br>CR20 not lighted.<br>CR21 not lighted.<br>CR24 not lighted.<br>CR25 not lighted.<br>CR26 not lighted. |
| 42.          | Test set.                                  |               | Set S7 to LOGIC 0.<br>Set S34 to URSC 1.                          |                                 | 930 +/- 100 microseconds.<br>CR22 lighted<br>CR20 not lighted<br>CR21 not lighted<br>CR23 not lighted.  |
| 42.1         | Test set.                                  |               | Set S9 to LOGIC 1.<br><br>Set S10 to LOGIC 1.                     |                                 | CR21 lighted.<br>CR22 lighted.<br>CR20 lighted.<br>CR21 lighted.<br>CR22 lighted.<br>CR23 not lighted.  |
| 43.          |  |               | Set the following switches as indicated:                          |                                 |   |
|              |  |               | <u>Control</u>  | <u>Position</u>                 |   |
|              |  |               | S7  | LOGIC 1                         |   |
|              |  |               | S9  | LOGIC 0                         |   |
|              |  |               | S10   | LOGIC 0                         |   |
|              |  |               | S31   | IC                              |   |
| 44.          |  |               | Apply 8.0 +/- 0.3 V p-p @ 600 +/- 60 Hz to J2 and J3, under load. |                                 | 600 Hz tone from LS1.   |

Table 5-4. SDU CCAs Performance Tests - Continued

| Step           | Connection of test equipment   | Point of test | Control settings and operation of equipment   | Performance standard |                 |     |         |                    |         |  |            |     |        |     |        |     |        |    |         |  |
|----------------|--|---------------|---|----------------------|-----------------|-----|---------|--------------------|---------|--|------------|-----|--------|-----|--------|-----|--------|----|---------|--|
| 45.            | Oscilloscope.  |               | Set S2 to HF-SSB, check voltage:<br><br><table data-bbox="607 548 915 642"> <thead> <tr> <th data-bbox="607 548 672 579"><u>From</u></th> <th data-bbox="850 548 899 579"><u>To</u></th> </tr> </thead> <tbody> <tr> <td data-bbox="607 611 656 642">TP8</td> <td data-bbox="850 611 899 642">TP9</td> </tr> </tbody> </table>  | <u>From</u>          | <u>To</u>       | TP8 | TP9     | 6.2 +/- 0.7 V p-p. |         |  |            |     |        |     |        |     |        |    |         |  |
| <u>From</u>    | <u>To</u>  |               |   |                      |                 |     |         |                    |         |  |            |     |        |     |        |     |        |    |         |  |
| TP8            | TP9  |               |   |                      |                 |     |         |                    |         |  |            |     |        |     |        |     |        |    |         |  |
| 46.            | Connect oscilloscope to measure time lag between zero crossings of input and output signals.<br><br>Time reference.<br><br>Measured reference. |               | <table data-bbox="607 978 915 1136"> <thead> <tr> <th data-bbox="607 978 672 1010"><u>From</u></th> <th data-bbox="850 978 899 1010"><u>To</u></th> </tr> </thead> <tbody> <tr> <td data-bbox="607 1041 639 1073">J2</td> <td data-bbox="850 1041 883 1073">J3</td> </tr> <tr> <td data-bbox="607 1104 656 1136">TP8</td> <td data-bbox="850 1104 899 1136">TP9</td> </tr> </tbody> </table>  | <u>From</u>          | <u>To</u>       | J2  | J3      | TP8                | TP9     | 120 +/- 40 microseconds.<br>CR9 not lighted. |            |     |        |     |        |     |        |    |         |  |
| <u>From</u>    | <u>To</u>  |               |   |                      |                 |     |         |                    |         |  |            |     |        |     |        |     |        |    |         |  |
| J2             | J3   |               |   |                      |                 |     |         |                    |         |  |            |     |        |     |        |     |        |    |         |  |
| TP8            | TP9  |               |   |                      |                 |     |         |                    |         |  |            |     |        |     |        |     |        |    |         |  |
| 47.            |  |               | Apply 0.10 +/- 0.03 V p-p @ 600 Hz +/- 60 Hz to J2 and J3, under load.  | CR9 lighted.         |                 |     |         |                    |         |  |            |     |        |     |        |     |        |    |         |  |
|                |  |               | HF-SSB CIRCUIT TESTS  |                      |                 |     |         |                    |         |  |            |     |        |     |        |     |        |    |         |  |
| 48.            | Test set.  |               | Set the following switches to positions indicated:<br><br><table data-bbox="607 1535 980 1808"> <thead> <tr> <th data-bbox="607 1535 721 1566"><u>Control</u></th> <th data-bbox="850 1535 980 1566"><u>Position</u></th> </tr> </thead> <tbody> <tr> <td data-bbox="607 1598 639 1629">S4</td> <td data-bbox="850 1598 964 1629">LOGIC 0</td> </tr> <tr> <td data-bbox="607 1640 639 1671">S6</td> <td data-bbox="850 1640 964 1671">LOGIC 1</td> </tr> <tr> <td data-bbox="607 1682 656 1713">S31</td> <td data-bbox="850 1682 1013 1713">STD ENCODE</td> </tr> <tr> <td data-bbox="607 1724 656 1755">S32</td> <td data-bbox="850 1724 948 1755">HF-SSB</td> </tr> <tr> <td data-bbox="607 1766 656 1797">S33</td> <td data-bbox="850 1766 948 1797">HF-SSB</td> </tr> <tr> <td data-bbox="607 1808 656 1839">S34</td> <td data-bbox="850 1808 948 1839">URSC-2</td> </tr> <tr> <td data-bbox="607 1850 639 1881">S5</td> <td data-bbox="850 1850 964 1881">LOGIC 1</td> </tr> </tbody> </table> | <u>Control</u>       | <u>Position</u> | S4  | LOGIC 0 | S6                 | LOGIC 1 | S31  | STD ENCODE | S32 | HF-SSB | S33 | HF-SSB | S34 | URSC-2 | S5 | LOGIC 1 |  |
| <u>Control</u> | <u>Position</u>  |               |   |                      |                 |     |         |                    |         |  |            |     |        |     |        |     |        |    |         |  |
| S4             | LOGIC 0  |               |   |                      |                 |     |         |                    |         |  |            |     |        |     |        |     |        |    |         |  |
| S6             | LOGIC 1  |               |   |                      |                 |     |         |                    |         |  |            |     |        |     |        |     |        |    |         |  |
| S31            | STD ENCODE   |               |   |                      |                 |     |         |                    |         |  |            |     |        |     |        |     |        |    |         |  |
| S32            | HF-SSB   |               |   |                      |                 |     |         |                    |         |  |            |     |        |     |        |     |        |    |         |  |
| S33            | HF-SSB   |               |   |                      |                 |     |         |                    |         |  |            |     |        |     |        |     |        |    |         |  |
| S34            | URSC-2   |               |   |                      |                 |     |         |                    |         |  |            |     |        |     |        |     |        |    |         |  |
| S5             | LOGIC 1  |               |   |                      |                 |     |         |                    |         |  |            |     |        |     |        |     |        |    |         |  |



Table 5-4. SDU GCAs Performance Tests - Continued

| Step   | Connection of test equipment | Point of test   | Control settings and operation of equipment                       | Performance standard  |                    |         |                   |            |     |        |     |        |     |        |                       |
|--|------------------------------|-----------------|---|-----------------------|--------------------|---------|-------------------|------------|-----|--------|-----|--------|-----|--------|-----------------------|
| 49.  | Oscilloscope.                |                 | Apply 5.5 +/- 0.2 V p-p @ 600 +/- 60 Hz to J2 and J3, under load. | 600 Hz tone from LS1. |                    |         |                   |            |     |        |     |        |     |        |                       |
| 50.  |                              |                 | Set S2 to STD DECODE.<br>Check voltage:                           |                       |                    |         |                   |            |     |        |     |        |     |        |                       |
| <table border="0"> <thead> <tr> <th data-bbox="704 646 773 674"><u>From</u></th> <th data-bbox="992 646 1029 674"><u>To</u></th> </tr> </thead> <tbody> <tr> <td data-bbox="704 705 773 732">TP64</td> <td data-bbox="992 705 1060 732">TP67</td> </tr> </tbody> </table>  |                              |                 | <u>From</u>   | <u>To</u>             | TP64               | TP67    | 4.8 +/- 0.6 V p-p |            |     |        |     |        |     |        |                       |
| <u>From</u>  | <u>To</u>                    |                 |   |                       |                    |         |                   |            |     |        |     |        |     |        |                       |
| TP64   | TP67                         |                 |   |                       |                    |         |                   |            |     |        |     |        |     |        |                       |
| Set S31 to HF-SSB.   | 600 Hz tone from LS1.        |                 |   |                       |                    |         |                   |            |     |        |     |        |     |        |                       |
| Set S2 to VHF-FM.  |                              |                 |   |                       |                    |         |                   |            |     |        |     |        |     |        |                       |
| NOTE   |                              |                 |   |                       |                    |         |                   |            |     |        |     |        |     |        |                       |
| Ensure audio generator output is still 5.5 V p-p, loaded.  |                              |                 |   |                       |                    |         |                   |            |     |        |     |        |     |        |                       |
| Check voltage:   |                              |                 |   |                       |                    |         |                   |            |     |        |     |        |     |        |                       |
| <table border="0"> <thead> <tr> <th data-bbox="704 1142 773 1169"><u>From</u></th> <th data-bbox="992 1142 1029 1169"><u>To</u></th> </tr> </thead> <tbody> <tr> <td data-bbox="704 1201 756 1228">TP8</td> <td data-bbox="992 1201 1044 1228">TP9</td> </tr> </tbody> </table>  | <u>From</u>                  | <u>To</u>       | TP8   | TP9                   | 6.0 +/- 0.7 V p-p. |         |                   |            |     |        |     |        |     |        |                       |
| <u>From</u>  | <u>To</u>                    |                 |   |                       |                    |         |                   |            |     |        |     |        |     |        |                       |
| TP8  | TP9                          |                 |   |                       |                    |         |                   |            |     |        |     |        |     |        |                       |
| VHF-FM CIRCUIT TESTS   |                              |                 |   |                       |                    |         |                   |            |     |        |     |        |     |        |                       |
| 51. Test set.  |                              |                 | Set the following switches as indicated:                          |                       |                    |         |                   |            |     |        |     |        |     |        |                       |
| <table border="0"> <thead> <tr> <th data-bbox="704 1478 813 1505"><u>Control</u></th> <th data-bbox="943 1478 1068 1505"><u>Position</u></th> </tr> </thead> <tbody> <tr> <td data-bbox="704 1537 740 1564">S4</td> <td data-bbox="943 1537 1052 1564">LOGIC 1</td> </tr> <tr> <td data-bbox="704 1570 740 1598">S5</td> <td data-bbox="943 1570 1052 1598">LOGIC 0</td> </tr> <tr> <td data-bbox="704 1604 756 1631">S31</td> <td data-bbox="943 1604 1101 1631">STD ENCODE</td> </tr> <tr> <td data-bbox="704 1638 756 1665">S32</td> <td data-bbox="943 1638 1040 1665">VHF-FM</td> </tr> <tr> <td data-bbox="704 1671 756 1698">S33</td> <td data-bbox="943 1671 1040 1698">VHF-FM</td> </tr> <tr> <td data-bbox="704 1705 756 1732">S34</td> <td data-bbox="943 1705 1040 1732">URSC-2</td> </tr> </tbody> </table> | <u>Control</u>               | <u>Position</u> | S4  | LOGIC 1               | S5                 | LOGIC 0 | S31               | STD ENCODE | S32 | VHF-FM | S33 | VHF-FM | S34 | URSC-2 | 600 Hz tone from LS1. |
| <u>Control</u>   | <u>Position</u>              |                 |   |                       |                    |         |                   |            |     |        |     |        |     |        |                       |
| S4   | LOGIC 1                      |                 |   |                       |                    |         |                   |            |     |        |     |        |     |        |                       |
| S5   | LOGIC 0                      |                 |   |                       |                    |         |                   |            |     |        |     |        |     |        |                       |
| S31  | STD ENCODE                   |                 |   |                       |                    |         |                   |            |     |        |     |        |     |        |                       |
| S32  | VHF-FM                       |                 |   |                       |                    |         |                   |            |     |        |     |        |     |        |                       |
| S33  | VHF-FM                       |                 |   |                       |                    |         |                   |            |     |        |     |        |     |        |                       |
| S34  | URSC-2                       |                 |   |                       |                    |         |                   |            |     |        |     |        |     |        |                       |

Table 5-4. SDU CCAs Performance Tests - Continued

| Step        | Connection of test equipment | Point of test | Control settings and operation of equipment  | Performance standard  |           |      |      |                      |
|-------------|------------------------------|---------------|--|-----------------------|-----------|------|------|----------------------|
| 52.         | Oscilloscope.                |               | Set S2 to STD DECODE.<br><br>NOTE<br><br>Ensure audio generator output is still 5.5 V p-p loaded.<br><br>Check voltage:<br><br><table border="0" style="width: 100%;"> <tr> <td style="text-align: left;"><u>From</u></td> <td style="text-align: right;"><u>To</u></td> </tr> <tr> <td>TP65</td> <td>TP68</td> </tr> </table> | <u>From</u>           | <u>To</u> | TP65 | TP68 | 0.08 +/- 0.02 V p-p. |
| <u>From</u> |                              | <u>To</u>     |  |                       |           |      |      |                      |
| TP65        | TP68                         |               |  |                       |           |      |      |                      |
| 53.         |                              |               | Set S31 to VHF-FM.<br>Apply 2.5 +/- 0.5 V p-p @ 600 +/- 60 Hz to J2 and J3.  | 600 Hz tone from LS1. |           |      |      |                      |
| 54.         |                              |               | Adjust voltage into J2 and J3 as needed for 28 V output at TP61 and TP68. Check voltage:<br><br><table border="0" style="width: 100%;"> <tr> <td style="text-align: left;"><u>From</u></td> <td style="text-align: right;"><u>To</u></td> </tr> <tr> <td>TP61</td> <td>TP68</td> </tr> </table>                                | <u>From</u>           | <u>To</u> | TP61 | TP68 | 28 +/- 1 V p-p.      |
| <u>From</u> | <u>To</u>                    |               |  |                       |           |      |      |                      |
| TP61        | TP68                         |               |  |                       |           |      |      |                      |
| 55.         |                              |               | Set S2 to UHF-AM.<br>Monitor voltage:<br><br><table border="0" style="width: 100%;"> <tr> <td style="text-align: left;"><u>From</u></td> <td style="text-align: right;"><u>To</u></td> </tr> <tr> <td>TP8</td> <td>TP9</td> </tr> </table>   | <u>From</u>           | <u>To</u> | TP8  | TP9  | 5.5 +/- 0.7 V p-p.   |
| <u>From</u> | <u>To</u>                    |               |  |                       |           |      |      |                      |
| TP8         | TP9                          |               |  |                       |           |      |      |                      |

Table 5-4. SDU CCAs Performance Tests - Continued

| Step | Connection of test equipment  | Point of test | Control settings and operation of equipment  | Performance standard  |
|------|---|---------------|--|---|
| 56.  | Set up oscilloscope to check the following wave forms for pulse duration and correct logic level. |               | LINE DECODER U13 TEST  | Logic 0 volts $\leq$ 0.5 V<br>Logic 1 volts $\geq$ TP58 volts -0.5 V (i.e., 8.5 VDC - 0.5 VDC = 8.0 VDC). |
|      |   |               | NOTE   |   |
|      |   |               | The test point ground is TP68, and the performance standard applies for all of the following measurements.   |   |
|      |   |               | <u>Control/</u><br><u>Position</u>   | <u>Test</u><br><u>Point</u>   |
|      |   |               | <u>S3</u> <u>S4</u> <u>S5</u> <u>S6</u>  |   |
|      |   |               | LOGIC 0 0 0 0 TP55<br>LOGIC 0 0 0 1 TP56<br>LOGIC 0 1 1 0 TP45<br>LOGIC 0 1 1 1 TP46<br>LOGIC 1 0 0 0 TP47<br>LOGIC 1 0 0 1 TP48<br>LOGIC 1 0 1 0 TP49<br>LOGIC 1 0 1 1 TP50<br>LOGIC 1 1 0 0 TP51<br>LOGIC 1 1 0 1 TP52<br>LOGIC 1 1 1 0 TP53<br>LOGIC 1 1 1 1 TP54 | Pulse duration:<br>70 +/- 5 microseconds.<br><br>Period: 3.2 +/- .2<br>milliseconds.                      |

Table 5-4. SDU CCAs Performance Tests - Continued

| Step | Connection of test equipment | Point of test | Control settings and operation of equipment | Performance standard |
|------|------------------------------|---------------|---|----------------------|
|      |                              |               | EQUIPMENT SHUT-OFF                          |                      |
| 57.  |                              |               | Turn S1 OFF.                                |                      |
| 58.  |                              |               | Normalize test equipment                    |                      |

Table 5-5. SDU CCAs Fault Isolation Tests

| Step   | Procedure  | Normal indication  | Fault location   |
|--|--|--|--|
| SET-UP FOR TEST OF SDU AUDIO INTERFACE 1 CCA |  |  |  |
| 1.   | Visually inspect Audio Interface CCA 1 (PN 812094).  | No visible damage, corrosion, broken or burned components, lifted or broken traces, etc.   | If damaged: repair or replace.   |
| 2.   | Connect test equipment as shown in Figure 5-2.<br><br>NOTE<br><br>When connecting for a negative voltage, connect red to positive and black to negative. Power cable W1 is wired to produce a negative voltage where needed. |  |  |
| 3.   | Turn on power supplies and adjust output.<br><br>NOTE<br><br>Switches, test points and indicators are on the test set (TS-4132/GRC-206) unless otherwise indicated.  | Adjust output voltages (open circuit) as follows:<br><br>(1) +17.5 +/- 0.5 Vdc<br>(2) +9.0 +/- 0.5 Vdc<br>(3) +5.0 +/- 0.5 Vdc<br>(4) -17.5 +/- 0.5 Vdc<br><br>Current limit, between 0.4 and 4.0 amps, short circuit. | DC Power Supply, Hewlett Packard, 6268B<br>DC Power Supply, Hewlett Packard, 6443B |
| 4.   | Slide in Audio Interface CCA #1 (PN 812094) into test panel card guides and mate with J4.  |  |  |

Table 5-5. SDU CCAs Fault Isolation Tests - Continued

| Step           | Procedure  | Normal indication  | Fault location  |    |          |     |        |     |         |     |     |     |   |     |   |    |         |    |          |     |        |     |        |     |        |    |            |    |         |    |         |    |         |    |         |    |         |     |         |      |        |      |  |
|----------------|--|--|-----------------|----|----------|-----|--------|-----|---------|-----|-----|-----|---|-----|---|----|---------|----|----------|-----|--------|-----|--------|-----|--------|----|------------|----|---------|----|---------|----|---------|----|---------|----|---------|-----|---------|------|--------|------|--|
| 5.             | <p>Connect pendant cable connectors P1, P2, and P3 from test fixture into circuit card connectors J1, J2, and J3, respectively.</p> <p style="text-align: center;">NOTE</p> <p>Switches may be in any position until a switch setting is specified. Ignore status of indicators not mentioned.</p>   |  |                 |    |          |     |        |     |         |     |     |     |   |     |   |    |         |    |          |     |        |     |        |     |        |    |            |    |         |    |         |    |         |    |         |    |         |     |         |      |        |      |  |
| 6.             | <p>Set switches as follows:</p> <table border="0" style="width: 100%;"> <thead> <tr> <th style="text-align: left;"><u>Control</u></th> <th style="text-align: left;"><u>Position</u></th> </tr> </thead> <tbody> <tr><td>R1</td><td>full CCW</td></tr> <tr><td>S14</td><td>MANUAL</td></tr> <tr><td>S15</td><td>BOARD 1</td></tr> <tr><td>S16</td><td>OFF</td></tr> <tr><td>S26</td><td>1</td></tr> <tr><td>S27</td><td>1</td></tr> <tr><td>R2</td><td>full CW</td></tr> <tr><td>R3</td><td>full CCW</td></tr> <tr><td>S18</td><td>VHF-AM</td></tr> <tr><td>S19</td><td>VHF-AM</td></tr> <tr><td>S20</td><td>VHF-AM</td></tr> <tr><td>S2</td><td>STD DECODE</td></tr> <tr><td>S5</td><td>LOGIC 1</td></tr> <tr><td>S6</td><td>LOGIC 1</td></tr> <tr><td>S7</td><td>LOGIC 1</td></tr> <tr><td>S8</td><td>LOGIC 1</td></tr> <tr><td>S9</td><td>LOGIC 0</td></tr> <tr><td>S10</td><td>LOGIC 0</td></tr> <tr><td>S35.</td><td>NORMAL</td></tr> </tbody> </table> | <u>Control</u>   | <u>Position</u> | R1 | full CCW | S14 | MANUAL | S15 | BOARD 1 | S16 | OFF | S26 | 1 | S27 | 1 | R2 | full CW | R3 | full CCW | S18 | VHF-AM | S19 | VHF-AM | S20 | VHF-AM | S2 | STD DECODE | S5 | LOGIC 1 | S6 | LOGIC 1 | S7 | LOGIC 1 | S8 | LOGIC 1 | S9 | LOGIC 0 | S10 | LOGIC 0 | S35. | NORMAL | NOTE |  |
| <u>Control</u> | <u>Position</u>  |  |                 |    |          |     |        |     |         |     |     |     |   |     |   |    |         |    |          |     |        |     |        |     |        |    |            |    |         |    |         |    |         |    |         |    |         |     |         |      |        |      |  |
| R1             | full CCW   |  |                 |    |          |     |        |     |         |     |     |     |   |     |   |    |         |    |          |     |        |     |        |     |        |    |            |    |         |    |         |    |         |    |         |    |         |     |         |      |        |      |  |
| S14            | MANUAL   |  |                 |    |          |     |        |     |         |     |     |     |   |     |   |    |         |    |          |     |        |     |        |     |        |    |            |    |         |    |         |    |         |    |         |    |         |     |         |      |        |      |  |
| S15            | BOARD 1  |  |                 |    |          |     |        |     |         |     |     |     |   |     |   |    |         |    |          |     |        |     |        |     |        |    |            |    |         |    |         |    |         |    |         |    |         |     |         |      |        |      |  |
| S16            | OFF  |  |                 |    |          |     |        |     |         |     |     |     |   |     |   |    |         |    |          |     |        |     |        |     |        |    |            |    |         |    |         |    |         |    |         |    |         |     |         |      |        |      |  |
| S26            | 1  |  |                 |    |          |     |        |     |         |     |     |     |   |     |   |    |         |    |          |     |        |     |        |     |        |    |            |    |         |    |         |    |         |    |         |    |         |     |         |      |        |      |  |
| S27            | 1  |  |                 |    |          |     |        |     |         |     |     |     |   |     |   |    |         |    |          |     |        |     |        |     |        |    |            |    |         |    |         |    |         |    |         |    |         |     |         |      |        |      |  |
| R2             | full CW  |  |                 |    |          |     |        |     |         |     |     |     |   |     |   |    |         |    |          |     |        |     |        |     |        |    |            |    |         |    |         |    |         |    |         |    |         |     |         |      |        |      |  |
| R3             | full CCW   |  |                 |    |          |     |        |     |         |     |     |     |   |     |   |    |         |    |          |     |        |     |        |     |        |    |            |    |         |    |         |    |         |    |         |    |         |     |         |      |        |      |  |
| S18            | VHF-AM   |  |                 |    |          |     |        |     |         |     |     |     |   |     |   |    |         |    |          |     |        |     |        |     |        |    |            |    |         |    |         |    |         |    |         |    |         |     |         |      |        |      |  |
| S19            | VHF-AM   |  |                 |    |          |     |        |     |         |     |     |     |   |     |   |    |         |    |          |     |        |     |        |     |        |    |            |    |         |    |         |    |         |    |         |    |         |     |         |      |        |      |  |
| S20            | VHF-AM   |  |                 |    |          |     |        |     |         |     |     |     |   |     |   |    |         |    |          |     |        |     |        |     |        |    |            |    |         |    |         |    |         |    |         |    |         |     |         |      |        |      |  |
| S2             | STD DECODE   |  |                 |    |          |     |        |     |         |     |     |     |   |     |   |    |         |    |          |     |        |     |        |     |        |    |            |    |         |    |         |    |         |    |         |    |         |     |         |      |        |      |  |
| S5             | LOGIC 1  |  |                 |    |          |     |        |     |         |     |     |     |   |     |   |    |         |    |          |     |        |     |        |     |        |    |            |    |         |    |         |    |         |    |         |    |         |     |         |      |        |      |  |
| S6             | LOGIC 1  |  |                 |    |          |     |        |     |         |     |     |     |   |     |   |    |         |    |          |     |        |     |        |     |        |    |            |    |         |    |         |    |         |    |         |    |         |     |         |      |        |      |  |
| S7             | LOGIC 1  |  |                 |    |          |     |        |     |         |     |     |     |   |     |   |    |         |    |          |     |        |     |        |     |        |    |            |    |         |    |         |    |         |    |         |    |         |     |         |      |        |      |  |
| S8             | LOGIC 1  |  |                 |    |          |     |        |     |         |     |     |     |   |     |   |    |         |    |          |     |        |     |        |     |        |    |            |    |         |    |         |    |         |    |         |    |         |     |         |      |        |      |  |
| S9             | LOGIC 0  |  |                 |    |          |     |        |     |         |     |     |     |   |     |   |    |         |    |          |     |        |     |        |     |        |    |            |    |         |    |         |    |         |    |         |    |         |     |         |      |        |      |  |
| S10            | LOGIC 0  |  |                 |    |          |     |        |     |         |     |     |     |   |     |   |    |         |    |          |     |        |     |        |     |        |    |            |    |         |    |         |    |         |    |         |    |         |     |         |      |        |      |  |
| S35.           | NORMAL   |  |                 |    |          |     |        |     |         |     |     |     |   |     |   |    |         |    |          |     |        |     |        |     |        |    |            |    |         |    |         |    |         |    |         |    |         |     |         |      |        |      |  |
|                |  | <p>S35 is located on top top of test set, on card guide.</p> |                 |    |          |     |        |     |         |     |     |     |   |     |   |    |         |    |          |     |        |     |        |     |        |    |            |    |         |    |         |    |         |    |         |    |         |     |         |      |        |      |  |
| 7.             | <p>Apply 10.0 +/- 0.4 V p-p @ 600 +/- 60 Hz to J2 and J3, under load.</p>  |  |                 |    |          |     |        |     |         |     |     |     |   |     |   |    |         |    |          |     |        |     |        |     |        |    |            |    |         |    |         |    |         |    |         |    |         |     |         |      |        |      |  |

Table 5-5. SDU CCAs Fault Isolation Tests - Continued

| Step                    | Procedure  | Normal indication                  | Fault location  |             |           |    |    |  |  |  |  |     |     |  |  |     |     |  |  |     |     |  |  |     |     |   |   |
|-------------------------|--|------------------------------------|---|-------------|-----------|----|----|--|--|--|--|-----|-----|--|--|-----|-----|--|--|-----|-----|--|--|-----|-----|---|---|
| POWER AND CIRCUIT TESTS |  |                                    |   |             |           |    |    |  |  |  |  |     |     |  |  |     |     |  |  |     |     |  |  |     |     |   |   |
| 8.                      | Adjust power supply voltages while monitoring the respective test points:  |                                    |   |             |           |    |    |  |  |  |  |     |     |  |  |     |     |  |  |     |     |  |  |     |     |   |   |
|                         | <table border="1" style="width: 100%; border-collapse: collapse;"> <thead> <tr> <th style="text-align: left;"><u>Control</u></th> <th style="text-align: left;"><u>Position</u></th> <th style="text-align: left;"><u>From</u></th> <th style="text-align: left;"><u>To</u></th> </tr> </thead> <tbody> <tr> <td>S1</td> <td>ON</td> <td></td> <td></td> </tr> <tr> <td></td> <td></td> <td>TP1</td> <td>TP7</td> </tr> <tr> <td></td> <td></td> <td>TP2</td> <td>TP7</td> </tr> <tr> <td></td> <td></td> <td>TP3</td> <td>TP7</td> </tr> <tr> <td></td> <td></td> <td>TP4</td> <td>TP7</td> </tr> </tbody> </table> | <u>Control</u>                     | <u>Position</u>   | <u>From</u> | <u>To</u> | S1 | ON |  |  |  |  | TP1 | TP7 |  |  | TP2 | TP7 |  |  | TP3 | TP7 |  |  | TP4 | TP7 | CR1, CR2, CR3, CR4 are lighted.<br>+17.5 +/- 0.5 Vdc<br>+9.0 +/- 0.5 Vdc<br>+5.0 +/- 0.5 Vdc<br>-17.5 +/- 0.5 Vdc | Normal indications present: step 9.<br>Absent: Power supplies, switch, LEDs or associated components. |
| <u>Control</u>          | <u>Position</u>  | <u>From</u>                        | <u>To</u>   |             |           |    |    |  |  |  |  |     |     |  |  |     |     |  |  |     |     |  |  |     |     |   |   |
| S1                      | ON   |                                    |   |             |           |    |    |  |  |  |  |     |     |  |  |     |     |  |  |     |     |  |  |     |     |   |   |
|                         |  | TP1                                | TP7   |             |           |    |    |  |  |  |  |     |     |  |  |     |     |  |  |     |     |  |  |     |     |   |   |
|                         |  | TP2                                | TP7   |             |           |    |    |  |  |  |  |     |     |  |  |     |     |  |  |     |     |  |  |     |     |   |   |
|                         |  | TP3                                | TP7   |             |           |    |    |  |  |  |  |     |     |  |  |     |     |  |  |     |     |  |  |     |     |   |   |
|                         |  | TP4                                | TP7   |             |           |    |    |  |  |  |  |     |     |  |  |     |     |  |  |     |     |  |  |     |     |   |   |
| 9.                      | Press and hold S22.<br>Release S22.  | CR14 lighted.<br>CR14 not lighted. | Normal indications present: step 10.<br>Absent: U12, U13, CR5 or associated components.               |             |           |    |    |  |  |  |  |     |     |  |  |     |     |  |  |     |     |  |  |     |     |   |   |
| 10.                     | Press and hold S23.<br>Release S23.  | CR15 lighted.<br>CR15 not lighted. | Normal indications present: step 11.<br>Absent: U12, U13, Q1, CR1, CR2, R19 or associated components. |             |           |    |    |  |  |  |  |     |     |  |  |     |     |  |  |     |     |  |  |     |     |   |   |
| 11.                     | Press and hold S24.<br>Release S24.  | CR16 lighted.<br>CR16 not lighted. | Normal indications present: step 12.<br>Absent: U12, U13 or associated components.                    |             |           |    |    |  |  |  |  |     |     |  |  |     |     |  |  |     |     |  |  |     |     |   |   |
| 12.                     | Set and hold S25 in the A1 position.<br>Release S25.   | CR17 not lighted.<br>CR17 lighted. | Normal indications present: step 13.<br>Absent: U13 or associated components.                         |             |           |    |    |  |  |  |  |     |     |  |  |     |     |  |  |     |     |  |  |     |     |   |   |

Table 5-5. SDU CCAs Fault Isolation Tests - Continued

| Step                 | Procedure   | Normal indication  | Fault location  |
|----------------------|---|--|---|
| 13.                  | <p>Set and hold S25 in the A2 position.<br/>Release S25.</p> <p style="text-align: center;">NOTE</p> <p>Ensure audio generator output is still 10 V p-p loaded.</p> | <p>CR17 not lighted.<br/>CR17 lighted.</p>                 | <p>Normal indications present: step 14.<br/>Absent: U13 or associated components.</p>                   |
| VHF-AM CIRCUIT TESTS |   |  |   |
| 14.                  | <p>Press S30.<br/>Adjust R1 for convenient hearing.</p>   | <p>600 Hz tone from LS1.</p>                               | <p>Normal indications present: step 15.<br/>Absent: U21, U27, U26, U3, U1 or associated components.</p> |
| 15.                  | <p>Set S2 to UHF-AM.<br/>Read voltage between TP8 and TP9 (STD DECODE).</p>   | <p>5.2 +/- 0.7 V p-p<br/>CR18 not lighted.</p>             | <p>Normal indications present: step 16.<br/>Absent: S1, R2, U9, or associated components.</p>           |
| 16.                  | <p>Set S8 to LOGIC 0.<br/><br/>Press S30.</p>   | <p>CR18 lighted.</p>                                       | <p>Normal indications present: step 17.<br/>Absent: U21, U12, U13 or associated components.</p>         |
| 17.                  | <p>Set S7 to LOGIC 0.<br/><br/>Press S30.</p> <p style="text-align: center;">NOTE</p> <p>Verify audio generator output is still 10 V p-p loaded.</p>                | <p>Audio present at TP8.<br/>Audio not present at TP8.</p> | <p>Normal indications present: step 18.<br/>Absent: U21, U25, U26 or associated components.</p>         |



Table 5-5. SDU CCAs Fault Isolation Tests - Continued

| Step                         | Procedure  | Normal indication  | Fault location  |
|------------------------------|--|--|---|
| UHF-AM CIRCUIT TESTS         |  |  |   |
| 18.                          | Set S7 to LOGIC 1.<br>Press S29.<br>Set S18 to UHF-AM.<br>Set S19 to UHF-AM.<br>Set S20 to UHF-AM. | CR19 lighted.  | Normal indications present: step 19.<br>Absent: U21, U17, U20, U3, U1 or associated components. |
| 19.                          | Set S8 to LOGIC 1.<br>Press S29.   | CR19 not lighted.  |   |
| 20.                          | Set S2 to STD DECODE.  | 600 Hz tone from LS1.  | Normal indications present: step 21.<br>Absent: same components as in step 19.                  |
| 21.                          | Set S7 to LOGIC 0.<br><br>Press S29.   | Audio present at TP8.<br>Audio not present at TP8.<br>600 Hz audio tone absent from LS1. | Normal indications present: step 22.<br>Absent: U21, U19, U20, or associated components.        |
| TEST SET A/D CONVERSION TEST |  |  |   |
| 22.                          | Set S20 to STD ENCODE.<br>Set S8 to LOGIC 0.<br>Press S29.   | CR19 lights when S29 is pressed  |   |
| 23.                          | Apply 5.0 +/- 0.2 V p-p @ 600 +/- 60 Hz to J2 and J3, under load.                                  | 600 Hz tone from LS1 absent.   | Normal indications present: step 24.<br>Absent: U21, U14, U15 or associated components.         |

Table 5-5. SDU CCAs Fault Isolation Tests - Continued

| Step                             | Procedure  | Normal indication          | Fault location  |
|----------------------------------|--|----------------------------|---|
| UHF-AM D/A AND PTT CIRCUIT CHECK |  |                            |   |
| 24.                              | Set S2 to VHF-AM.<br>Check signal between TP18 and TP21. | 0.10 +/- 0.02 V p-p.       | Normal indications present: step 25.<br>Absent: U3, U15, U16, U17 or associated components. |
| 25.                              | Set S8 to LOGIC 1.<br>Press S29.                         | Audio not present at TP18. | Normal indications present: step 26.<br>Absent: U21, U14, U15 or associated components.     |
| 26.                              | Set S8 to LOGIC 0.<br>Press S29.                         | Audio present at TP18.     | Normal indications present: step 27.<br>Absent: same component, as in Step 25.              |
| 27.                              | Set S10 to LOGIC 1.<br>Press S29.                        | Audio not present at TP18. | Normal indications present: step 28.<br>Absent: U21, U14, U15 or associated components.     |
| 28.                              | Set S10 to LOGIC 0.<br>Press S29.                        | Audio present at TP18.     | Normal indications present: step 29.<br>Absent: same components, as in Step 27.             |

## NOTE

Verify audio generator output is still 5 V p-p loaded.

Table 5-5. SDU CCAs Fault Isolation Tests - Continued

| Step                      | Procedure   | Normal indication                      | Fault location   |
|---------------------------|---|--|--|
| VHF-AM PTT CIRCUIT CHECKS |   |  |  |
| 29.                       | Set switches S18 and S19 to VHF-AM.<br>Press S30.                   | 600 Hz tone from LS1.                  | Normal indications present: step 30.<br>Absent: U27, U26, U3, U1 or associated components. |
| 30.                       | Set S2 to IC position.<br>Check signal from TP19 to TP21.           | 0.10 +/- 0.02 V p-p.                   | Normal indications present: step 31.<br>Absent: U27, U26, U3, U1 or associated components. |
| 31.                       | Set S8 to LOGIC 1.<br>Press S30.<br>Check signal from TP19 to TP21. | Audio not present.                     | Normal indications present: step 32.<br>Absent: U21, U22, U23 or associated components.    |
| 32.                       | Set S8 to LOGIC 0.<br>Press S30.                                    | Audio present at TP19.<br>CR18 lights. | Normal indications present: step 33.<br>Absent: same components as in step 31.             |
| 33.                       | Set S10 to LOGIC 1.<br>Press S30.                                   | Audio not present at TP19.             | Normal indications present: step 34.<br>Absent: U21, U22, U23 or associated components.    |

Table 5-5. SDU CCAs Fault Isolation Tests - Continued

| Step                  | Procedure   | Normal indication      | Fault location   |      |      |      |      |      |      |  |  |
|-----------------------|---|------------------------|--|------|------|------|------|------|------|--|--|
| 34.                   | Set S10 to LOGIC 0.<br>Press S30.   | Audio present at TP19. | Normal indications present: step 35.<br>Absent: same components as in step 33. |      |      |      |      |      |      |  |  |
| TIMING CIRCUIT CHECKS |   |                        |  |      |      |      |      |      |      |  |  |
| 35.                   | <p>Set up oscilloscope to check the following waveforms for frequency and correct logic level:</p> <table border="0" data-bbox="194 966 747 1593"> <thead> <tr> <th data-bbox="194 966 535 1008"><u>From</u></th> <th data-bbox="535 966 747 1008"><u>To</u></th> </tr> </thead> <tbody> <tr> <td data-bbox="194 1008 535 1092">TP24</td> <td data-bbox="535 1008 747 1092">TP70</td> </tr> <tr> <td data-bbox="194 1092 535 1386">TP25</td> <td data-bbox="535 1092 747 1386">TP70</td> </tr> <tr> <td data-bbox="194 1386 535 1593">TP28</td> <td data-bbox="535 1386 747 1593">TP70</td> </tr> </tbody> </table> | <u>From</u>            | <u>To</u>  | TP24 | TP70 | TP25 | TP70 | TP28 | TP70 | <p>LOGIC 0 volts, &lt;=0.5 V.<br/>LOGIC 1 volts, &gt;=TP2 volts -0.5 V (e.g., 9.2 V -0.5 V = 8.7 V)</p> <p>25 kHz +/- 7%</p> <p>25 kHz +/- 7%</p> <p>25 kHz +/- 7%</p> | <p>Present: next test point.<br/>Absent: U10, U3, U4, U8 or associated components.</p> <p>Present: next test point.<br/>Absent: U11, U8, U6, or associated components.</p> <p>Present: next test point.<br/>Absent: U4, U8, U3 or associated components.</p> |
| <u>From</u>           | <u>To</u>   |                        |  |      |      |      |      |      |      |  |  |
| TP24                  | TP70  |                        |  |      |      |      |      |      |      |  |  |
| TP25                  | TP70  |                        |  |      |      |      |      |      |      |  |  |
| TP28                  | TP70  |                        |  |      |      |      |      |      |      |  |  |

Table 5-5. SDU CCAs Fault Isolation Tests - Continued

| Step   | Procedure  | Normal indication  | Fault location  |
|--|--|--|---|
| 35.<br>cont.                                 | TP26 • TP70  | 50 kHz +/- 7%  | Present: next test point.<br>Absent: U10, U8, U4, or associated components. |
|  | TP27 TP70  | 50 kHz +/- 7%  | Present: next test point.<br>Absent: U11, U8, U4, or associated components. |
|  | TP37 TP70  | 50 kHz +/- 7%  | Present: step 36.<br>Absent: U8, U4, associated components.                 |
| END OF CCA #1 TESTS                          |  |  |   |
| 36.  | Set S1 to OFF.   |  |   |
| 37.  | Disconnect P1, P2, and P3 from circuit card mated to J4 of test set. Disconnect J4.  |  |   |
| 38.  | Remove Audio Interface CCA #1 from card guides.  |  |   |
| SET-UP FOR TEST OF SDU AUDIO INTERFACE 2 CCA |  |  |   |
| 39.  | Visually inspect Audio Interface CCA #2 (PN 812095).<br><br>Slide Audio Interface CCA #2 into test panel card guides and mate with J5. | No visible damage, corrosion, burned or broken components, lifted traces, etc. | If damaged: repair or replace.  |

Table 5-5. SDU CCAs Fault Isolation Tests - Continued

| Step           | Procedure  | Normal indication                                     | Fault location  |     |         |     |            |     |      |     |      |  |  |    |         |    |         |    |         |    |         |    |         |    |         |    |         |     |         |  |  |
|----------------|--|---|-----------------|-----|---------|-----|------------|-----|------|-----|------|--|--|----|---------|----|---------|----|---------|----|---------|----|---------|----|---------|----|---------|-----|---------|--|--|
| 40.            | Apply 5.0 +/- 0.2 V p-p @ 600 +/- 60 Hz to J2 and J3 under load.   |   |                 |     |         |     |            |     |      |     |      |  |  |    |         |    |         |    |         |    |         |    |         |    |         |    |         |     |         |  |  |
| 41.            | Turn S1 ON.  | CR1, CR2, CR3 and CR4 light to show power is applied. |                 |     |         |     |            |     |      |     |      |  |  |    |         |    |         |    |         |    |         |    |         |    |         |    |         |     |         |  |  |
| 42.            | <p>Check for following DC voltages:</p> <table border="0" data-bbox="207 674 743 863"> <thead> <tr> <th><u>From</u></th> <th><u>To</u></th> </tr> </thead> <tbody> <tr> <td>TP1</td> <td>TP5</td> </tr> <tr> <td>TP2</td> <td>TP6</td> </tr> <tr> <td>TP6</td> <td>TP58</td> </tr> <tr> <td>TP5</td> <td>TP59</td> </tr> </tbody> </table>   | <u>From</u>   | <u>To</u>       | TP1 | TP5     | TP2 | TP6        | TP6 | TP58 | TP5 | TP59 | <p>5 mV max.<br/>0.22 V max.<br/>1.1 V max.<br/>0.1 V max.</p> | <p>If voltage is above maximum allowed, check power supplies output.</p> |    |         |    |         |    |         |    |         |    |         |    |         |    |         |     |         |  |  |
| <u>From</u>    | <u>To</u>  |   |                 |     |         |     |            |     |      |     |      |  |  |    |         |    |         |    |         |    |         |    |         |    |         |    |         |     |         |  |  |
| TP1            | TP5  |   |                 |     |         |     |            |     |      |     |      |  |  |    |         |    |         |    |         |    |         |    |         |    |         |    |         |     |         |  |  |
| TP2            | TP6  |   |                 |     |         |     |            |     |      |     |      |  |  |    |         |    |         |    |         |    |         |    |         |    |         |    |         |     |         |  |  |
| TP6            | TP58   |   |                 |     |         |     |            |     |      |     |      |  |  |    |         |    |         |    |         |    |         |    |         |    |         |    |         |     |         |  |  |
| TP5            | TP59   |   |                 |     |         |     |            |     |      |     |      |  |  |    |         |    |         |    |         |    |         |    |         |    |         |    |         |     |         |  |  |
| 43.            | <p>Set test set switches as follows:</p> <table border="0" data-bbox="207 947 743 1409"> <thead> <tr> <th><u>Control</u></th> <th><u>Position</u></th> </tr> </thead> <tbody> <tr> <td>S15</td> <td>BOARD 2</td> </tr> <tr> <td>S31</td> <td>STD ENCODE</td> </tr> <tr> <td>S32</td> <td>IC</td> </tr> <tr> <td>S33</td> <td>IC</td> </tr> <tr> <td>S34</td> <td>2</td> </tr> <tr> <td>S3</td> <td>LOGIC 1</td> </tr> <tr> <td>S4</td> <td>LOGIC 1</td> </tr> <tr> <td>S5</td> <td>LOGIC 1</td> </tr> <tr> <td>S6</td> <td>LOGIC 1</td> </tr> <tr> <td>S7</td> <td>LOGIC 1</td> </tr> <tr> <td>S8</td> <td>LOGIC 1</td> </tr> <tr> <td>S9</td> <td>LOGIC 1</td> </tr> <tr> <td>S10</td> <td>LOGIC 1</td> </tr> </tbody> </table> <p>Press S17.</p> <p style="text-align: center;">NOTE</p> <p>Verify audio generator output is still 5.0 +/- 0.2 V p-p loaded.</p> | <u>Control</u>  | <u>Position</u> | S15 | BOARD 2 | S31 | STD ENCODE | S32 | IC   | S33 | IC   | S34  | 2  | S3 | LOGIC 1 | S4 | LOGIC 1 | S5 | LOGIC 1 | S6 | LOGIC 1 | S7 | LOGIC 1 | S8 | LOGIC 1 | S9 | LOGIC 1 | S10 | LOGIC 1 |  |  |
| <u>Control</u> | <u>Position</u>  |   |                 |     |         |     |            |     |      |     |      |  |  |    |         |    |         |    |         |    |         |    |         |    |         |    |         |     |         |  |  |
| S15            | BOARD 2  |   |                 |     |         |     |            |     |      |     |      |  |  |    |         |    |         |    |         |    |         |    |         |    |         |    |         |     |         |  |  |
| S31            | STD ENCODE   |   |                 |     |         |     |            |     |      |     |      |  |  |    |         |    |         |    |         |    |         |    |         |    |         |    |         |     |         |  |  |
| S32            | IC   |   |                 |     |         |     |            |     |      |     |      |  |  |    |         |    |         |    |         |    |         |    |         |    |         |    |         |     |         |  |  |
| S33            | IC   |   |                 |     |         |     |            |     |      |     |      |  |  |    |         |    |         |    |         |    |         |    |         |    |         |    |         |     |         |  |  |
| S34            | 2  |   |                 |     |         |     |            |     |      |     |      |  |  |    |         |    |         |    |         |    |         |    |         |    |         |    |         |     |         |  |  |
| S3             | LOGIC 1  |   |                 |     |         |     |            |     |      |     |      |  |  |    |         |    |         |    |         |    |         |    |         |    |         |    |         |     |         |  |  |
| S4             | LOGIC 1  |   |                 |     |         |     |            |     |      |     |      |  |  |    |         |    |         |    |         |    |         |    |         |    |         |    |         |     |         |  |  |
| S5             | LOGIC 1  |   |                 |     |         |     |            |     |      |     |      |  |  |    |         |    |         |    |         |    |         |    |         |    |         |    |         |     |         |  |  |
| S6             | LOGIC 1  |   |                 |     |         |     |            |     |      |     |      |  |  |    |         |    |         |    |         |    |         |    |         |    |         |    |         |     |         |  |  |
| S7             | LOGIC 1  |   |                 |     |         |     |            |     |      |     |      |  |  |    |         |    |         |    |         |    |         |    |         |    |         |    |         |     |         |  |  |
| S8             | LOGIC 1  |   |                 |     |         |     |            |     |      |     |      |  |  |    |         |    |         |    |         |    |         |    |         |    |         |    |         |     |         |  |  |
| S9             | LOGIC 1  |   |                 |     |         |     |            |     |      |     |      |  |  |    |         |    |         |    |         |    |         |    |         |    |         |    |         |     |         |  |  |
| S10            | LOGIC 1  |   |                 |     |         |     |            |     |      |     |      |  |  |    |         |    |         |    |         |    |         |    |         |    |         |    |         |     |         |  |  |

Table 5-5. SDU CCAs Fault Isolation Tests - Continued

| Step                       | Procedure   | Normal indication    | Fault location   |     |         |    |         |    |         |    |         |    |         |    |            |                       |  |
|----------------------------|---|----------------------|--|-----|---------|----|---------|----|---------|----|---------|----|---------|----|------------|-----------------------|--|
| INTERCOM D/A CIRCUIT TESTS |   |                      |  |     |         |    |         |    |         |    |         |    |         |    |            |                       |  |
| 44.                        | Set the following test set switches in the order listed:  |                      |  |     |         |    |         |    |         |    |         |    |         |    |            |                       |  |
|                            | <table border="0"> <thead> <tr> <th data-bbox="318 617 431 644"><u>Control</u></th> <th data-bbox="607 617 740 644"><u>Position</u></th> </tr> </thead> <tbody> <tr> <td data-bbox="318 678 367 705">S10</td> <td data-bbox="607 678 721 705">LOGIC 0</td> </tr> <tr> <td data-bbox="318 709 350 737">S9</td> <td data-bbox="607 709 721 737">LOGIC 0</td> </tr> <tr> <td data-bbox="318 741 350 768">S6</td> <td data-bbox="607 741 721 768">LOGIC 0</td> </tr> <tr> <td data-bbox="318 772 350 800">S5</td> <td data-bbox="607 772 721 800">LOGIC 0</td> </tr> <tr> <td data-bbox="318 804 350 831">S3</td> <td data-bbox="607 804 721 831">LOGIC 0</td> </tr> <tr> <td data-bbox="318 835 350 863">S2</td> <td data-bbox="607 835 769 863">STD DECODE</td> </tr> </tbody> </table> | <u>Control</u>       | <u>Position</u>  | S10 | LOGIC 0 | S9 | LOGIC 0 | S6 | LOGIC 0 | S5 | LOGIC 0 | S3 | LOGIC 0 | S2 | STD DECODE | 600 Hz tone from LS1. |  |
| <u>Control</u>             | <u>Position</u>   |                      |  |     |         |    |         |    |         |    |         |    |         |    |            |                       |  |
| S10                        | LOGIC 0   |                      |  |     |         |    |         |    |         |    |         |    |         |    |            |                       |  |
| S9                         | LOGIC 0   |                      |  |     |         |    |         |    |         |    |         |    |         |    |            |                       |  |
| S6                         | LOGIC 0   |                      |  |     |         |    |         |    |         |    |         |    |         |    |            |                       |  |
| S5                         | LOGIC 0   |                      |  |     |         |    |         |    |         |    |         |    |         |    |            |                       |  |
| S3                         | LOGIC 0   |                      |  |     |         |    |         |    |         |    |         |    |         |    |            |                       |  |
| S2                         | STD DECODE  |                      |  |     |         |    |         |    |         |    |         |    |         |    |            |                       |  |
|                            | Check voltage between TP63 and TP67.  | 10.0 +/- 1.1 V p-p.  | Normal indications present: step 45. Absent: U13, U14, U1, U9, U5, or associated components. |     |         |    |         |    |         |    |         |    |         |    |            |                       |  |
| INTERCOM CIRCUIT TESTS     |   |                      |  |     |         |    |         |    |         |    |         |    |         |    |            |                       |  |
| 45.                        | Connect oscilloscope to measure time lag between zero crossings of input and output signals.  |                      |  |     |         |    |         |    |         |    |         |    |         |    |            |                       |  |
| 46.                        | Connect time reference at J2 and J3. Connect measured ref. from TP63 to TP67.   | 100 +/- 30 microsec. | Normal indication present: step 47. Absent: U1, U9, U5, or associated components.            |     |         |    |         |    |         |    |         |    |         |    |            |                       |  |

Table 5-5. SDU CCAs Fault Isolation Tests - Continued

| Step           | Procedure   | Normal indication   | Fault location   |    |         |    |         |     |         |     |    |                       |  |
|----------------|---|---|--|----|---------|----|---------|-----|---------|-----|----|-----------------------|--|
| 47.            | Check for condition of the following LEDs:  | CR22 lighted.<br>CR23 lighted.<br>CR20 not lighted.<br>CR21 not lighted.<br>CR24 not lighted.<br>CR25 not lighted.<br>CR26 not lighted. | Normal indications present: step 48.<br>Absent: U12, U13, U14, or associated components. |    |         |    |         |     |         |     |    |                       |  |
| 48.            | Set test set S7 to LOGIC 0.<br>Set S34 to URSC 1.   | 930 +/- 100 micro-seconds.<br>CR22 lighted<br>CR20 not lighted<br>CR21 not lighted<br>CR23 not lighted.                                 |  |    |         |    |         |     |         |     |    |                       |  |
| 48.1.          | Set S9 to LOGIC 1.  | CR21 lighted.<br>CR22 lighted.  | Normal indications present: step 49.<br>Absent: U12, U13, U14, or associated components. |    |         |    |         |     |         |     |    |                       |  |
| 49.            | Set S10 to LOGIC 1.   | CR20 lighted.<br>CR21 lighted.<br>CR22 lighted.<br>CR23 not lighted.  | Normal indications present: step 50.<br>Absent: same components as in step 48.           |    |         |    |         |     |         |     |    |                       |  |
| 50.            | Set the following switches as indicated:<br><br><table border="0" data-bbox="204 1356 646 1541"> <thead> <tr> <th><u>Control</u></th> <th><u>Position</u></th> </tr> </thead> <tbody> <tr> <td>S7</td> <td>LOGIC 1</td> </tr> <tr> <td>S9</td> <td>LOGIC 0</td> </tr> <tr> <td>S10</td> <td>LOGIC 0</td> </tr> <tr> <td>S31</td> <td>IC</td> </tr> </tbody> </table> <p data-bbox="204 1577 678 1667">Apply 8.0 +/- 0.3 V p-p @ 600 Hz +/- 60 Hz under load to J2 and J3.</p> | <u>Control</u>  | <u>Position</u>  | S7 | LOGIC 1 | S9 | LOGIC 0 | S10 | LOGIC 0 | S31 | IC | 600 Hz tone from LS1. |  |
| <u>Control</u> | <u>Position</u>   |   |  |    |         |    |         |     |         |     |    |                       |  |
| S7             | LOGIC 1   |   |  |    |         |    |         |     |         |     |    |                       |  |
| S9             | LOGIC 0   |   |  |    |         |    |         |     |         |     |    |                       |  |
| S10            | LOGIC 0   |   |  |    |         |    |         |     |         |     |    |                       |  |
| S31            | IC  |   |  |    |         |    |         |     |         |     |    |                       |  |



Table 5-5. SDU CCAs Fault Isolation Tests - Continued

| Step                 | Procedure  | Normal indication  | Fault location   |
|----------------------|--|--|--|
| 51.                  | Set S2 to HF-SSB.<br>Check signal:<br><br><u>From</u> <u>To</u><br><br>TP8                              TP9  | 6.2 +/- 0.7 V p-p.   | Normal indications present: step 52.<br>Absent: S2, U12, U14, or associated components.  |
| 52.                  | Connect oscilloscope to measure time lag between zero crossings of input and output signals.<br>Connect time reference from J2 to J3.<br>Connect measured reference from TP8 to TP9.   | 120 +/- 40 micro-seconds.<br>CR8 not lighted.                  | Normal indications present: step 53.<br>Absent: U12, U13, U14, or associated components. |
| 53.                  | Apply 0.10 +/- 0.03 V p-p @ 600 +/- 60 Hz to J2 and J3 under load.   | 600 Hz tone from LS1. Signal may be very weak.<br>CR8 lighted. | Normal indications present: step 54.<br>Absent: U12, U13, U14, or associated components. |
| HF-SSB CIRCUIT TESTS |  |  |  |
| 54.                  | Set the following test set switches as indicated:<br><br><u>Control</u> <u>Position</u><br><br>S4                              LOGIC 0<br>S6                              LOGIC 1<br>S31                             STD ENCODE<br>S32                             HF-SSB<br>S33                             HF-SSB<br>S34                             URSC-2<br>S5                              LOGIC 1 |  |  |

Table 5-5. SDU CCAs Fault Isolation Tests - Continued

| Step                        | Procedure   | Normal indication   | Fault location  |    |         |    |         |     |            |     |        |     |        |     |        |  |  |
|-----------------------------|---|---|---|----|---------|----|---------|-----|------------|-----|--------|-----|--------|-----|--------|--|--|
| 55.                         | Apply 5.5 +/- 0.2 V p-p @ 600 +/- 60 Hz from J2 to J3, under load.  | 600 Hz tone from LS1.   | Normal indications present: step 56.<br>Absent: U17, U20, U18, U19, or associated components. |    |         |    |         |     |            |     |        |     |        |     |        |  |  |
| 56.                         | Set S2 to STD DECODE.<br>Check signal from TP64 to TP67.  | 4.8 +/- 0.6 V p-p.  | Normal indications present: step 57.<br>Absent: U16, U17, U18, U19, or associated components. |    |         |    |         |     |            |     |        |     |        |     |        |  |  |
| 57.                         | Set S31 to HF-SSB<br>Set S2 to VHF-FM.<br><br>NOTE<br><br>Verify audio generator output is still 5.5 V p-p loaded.<br><br>Check signal from TP8 to TP9.   | 600 Hz tone from LS1.<br><br><br><br><br><br>6.0 +/- 0.7 V p-p. | Normal indications present: step 58.<br>Absent: same components as in step 56.                |    |         |    |         |     |            |     |        |     |        |     |        |  |  |
| VHF-FM OUTPUT CIRCUIT TESTS |   |   |   |    |         |    |         |     |            |     |        |     |        |     |        |  |  |
| 58.                         | Set the following switches as indicated:<br><br><table border="0" data-bbox="203 1375 649 1638"> <thead> <tr> <th><u>Control</u></th> <th><u>Position</u></th> </tr> </thead> <tbody> <tr> <td>S4</td> <td>LOGIC 1</td> </tr> <tr> <td>S5</td> <td>LOGIC 0</td> </tr> <tr> <td>S31</td> <td>STD ENCODE</td> </tr> <tr> <td>S32</td> <td>VHF-FM</td> </tr> <tr> <td>S33</td> <td>VHF-FM</td> </tr> <tr> <td>S34</td> <td>URSC-2</td> </tr> </tbody> </table> | <u>Control</u>  | <u>Position</u>   | S4 | LOGIC 1 | S5 | LOGIC 0 | S31 | STD ENCODE | S32 | VHF-FM | S33 | VHF-FM | S34 | URSC-2 |  |  |
| <u>Control</u>              | <u>Position</u>   |   |   |    |         |    |         |     |            |     |        |     |        |     |        |  |  |
| S4                          | LOGIC 1   |   |   |    |         |    |         |     |            |     |        |     |        |     |        |  |  |
| S5                          | LOGIC 0   |   |   |    |         |    |         |     |            |     |        |     |        |     |        |  |  |
| S31                         | STD ENCODE  |   |   |    |         |    |         |     |            |     |        |     |        |     |        |  |  |
| S32                         | VHF-FM  |   |   |    |         |    |         |     |            |     |        |     |        |     |        |  |  |
| S33                         | VHF-FM  |   |   |    |         |    |         |     |            |     |        |     |        |     |        |  |  |
| S34                         | URSC-2  |   |   |    |         |    |         |     |            |     |        |     |        |     |        |  |  |



Table 5-5. SDU CCAs Fault Isolation Tests - Continued

| Step         | Procedure  | Normal indication   | Fault location   |
|--------------|--|---|--|
| 61.<br>cont. | <p><u>Control/Position</u>      <u>From</u></p> <p>    <u>S3</u> <u>S4</u> <u>S5</u> <u>S6</u></p> <p>LOGIC    0   0   0   0   TP55</p> <p>LOGIC    0   0   0   1   TP56</p> <p>LOGIC    0   1   1   0   TP45</p> <p>LOGIC    0   1   1   1   TP46</p> <p>LOGIC    1   0   0   0   TP47</p> <p>LOGIC    1   0   0   1   TP48</p> <p>LOGIC    1   0   1   0   TP49</p> <p>LOGIC    1   0   1   1   TP50</p> <p>LOGIC    1   1   0   0   TP51</p> <p>LOGIC    1   1   0   1   TP52</p> <p>LOGIC    1   1   1   0   TP53</p> <p>LOGIC    1   1   1   1   TP54</p> <p style="text-align: center;">EQUIPMENT SHUT-OFF</p> | <p>Pulse duration:<br/>70 +/- 5 micro<br/>seconds.<br/>Period: 3.2 +/- .2<br/>milliseconds.</p> | <p>Normal indications<br/>present: step 62.<br/>Absent: U12, U13,<br/>U13, or associated<br/>components.</p> |
| 62.          | Turn S1 OFF.   |   |  |
| 63.          | Normalize test equipment.  |   |  |

## 5-5. AUDIO INTERFACE (2) MAINTENANCE.

a. Bench Test Setup. The bench test setup of the audio interface (2) is included in figure 5-2.

CAUTION

Prior to handling electrostatic-sensitive electronic devices, personnel and equipment must be grounded to prevent static discharge damage to the device. Do not remove or install subassembly in test fixture with power applied or damage to equipment may result.

NOTE

Subassemblies shipped in nonapproved containers may be subject to multiple failures due to mishandling.

b. Component Performance Test Table. The component performance test for the audio interface (2) are contained in table 5-4. This table is keyed to fault isolation procedures in table 5-5.

c. Mechanical Assemblies. NOT APPLICABLE

d. Cleaning and Lubrication.

CAUTION

Prior to handling electrostatic-sensitive electronic devices, personnel and equipment must be grounded to prevent static discharge damage to the device.

NOTE

Prefix component reference designators of the audio interface (2) CCA with 1A2.

Clean the audio interface (2) CCA in accordance with TO 00-25-234.

e. Repair and Replacement. Repair of the audio interface (2) CCA consists of the removal of malfunctioning components and their replacement with serviceable components. Refer to IPB figure 7-5 for items that are SMR coded for repair at depot level. Upon receipt of an audio interface (2) CCA for repair at depot level, perform the following procedures:

CAUTION

Digital microcircuits U1 through U3, U7, U10 through U17, U20 through U24, and U27 are susceptible to electrostatic discharge damage.

Prior to handling electrostatic-sensitive electronic devices, personnel and equipment must be grounded to prevent static discharge damage to the device.

- (1) Visually inspect CCA for damage to components or traces from heat, deterioration, moisture, or deposits from oxidation or corrosion.
- (2) Check for broken wires, bent pins, frayed insulation, and poor soldering connections.
- (3) Check printed wiring board for cracks or delamination.
- (4) Replace defective components. Refer to figures 5-4 and 7-5 for component location and orientation. Maximum allowable component height of connectors J1 and J3 is 0.47 and 0.40 inches, respectively.
- (5) Perform all soldering and other electronic maintenance in accordance with TO 00-25-234 per MIL-STD-454, Requirement 5. Use solder Type SN60WRMAP2 per QQ-S-571.
- (6) Except for indicated areas in figure 5-4, cover both sides with conformal coating per MIL-I-46058, Type UR.

f. Reassembly and Testing of Subassemblies and Assemblies. Refer to the above paragraph, Repair and Replacement, for special reassembly instructions of the audio interface (2).

g. Testing. Perform the instructions contained in table 5-4, SDU CCAs Component Performance Test, to ensure the serviceable condition of the subassembly.

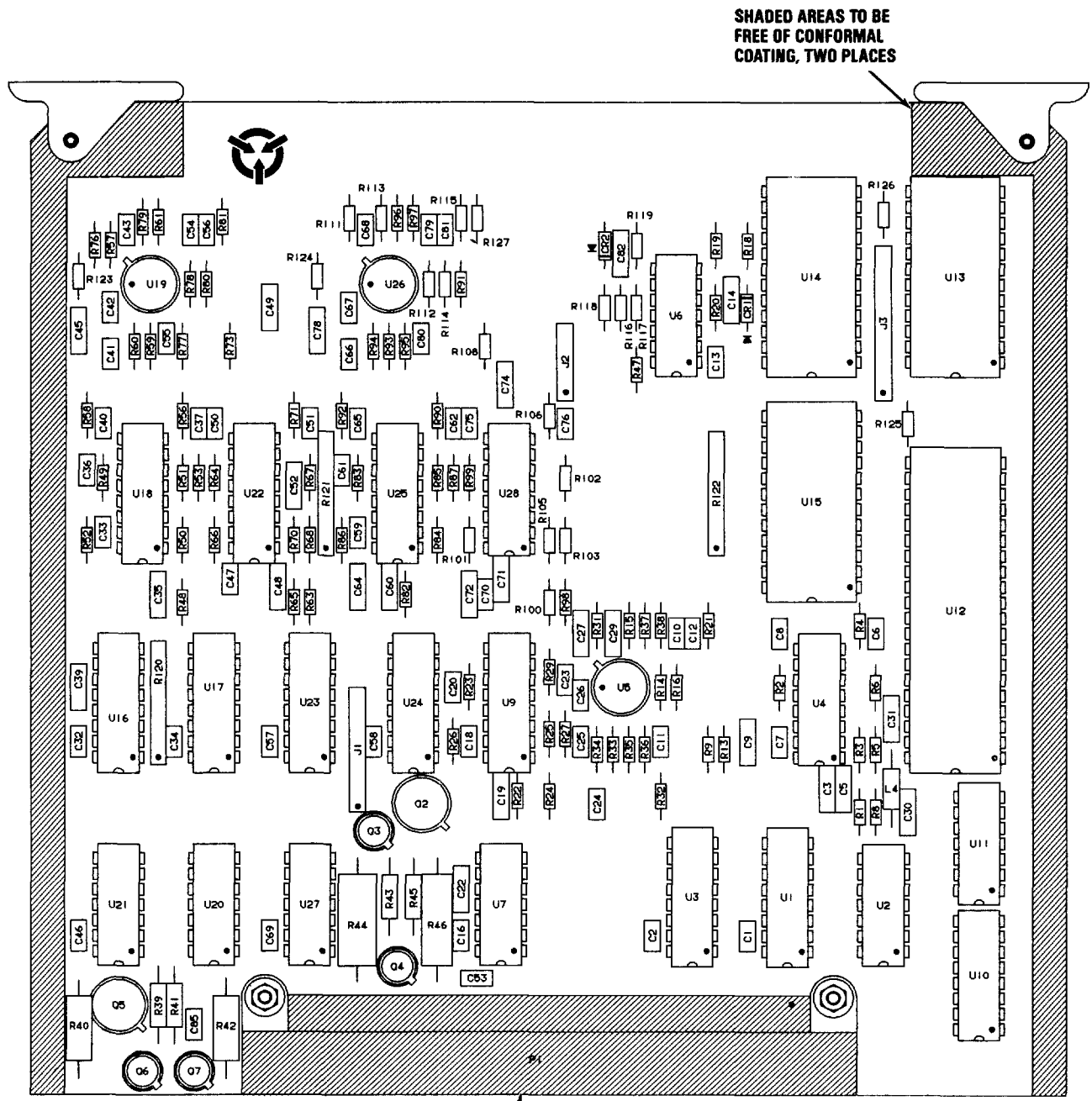

SHADED AREAS TO BE FREE OF CONFORMAL COATING, TWO PLACES

NOTE: REFERENCE DESIGNATIONS ARE ABBREVIATED. PREFIX WITH 1A2.

CONNECTOR PINS AND CONTACTS TO BE FREE OF CONFORMAL COATING, THREE PLACES.

MX-61-119-021  
REF MX DWG NO. 812084 REV J

Figure 5-4. Audio Interface (2) 1A2 Component Location

5-6. SDU POWER SUPPLY SUBASSEMBLY MAINTENANCE.

a. Bench Test Setup. The bench test setup of the SDU power supply is illustrated in figure 5-5. Refer to TO 00-25-234 for correct handling procedures of power supply subassembly.

CAUTION

Prior to handling electrostatic-sensitive electronic devices, personnel and equipment must be grounded to prevent static discharge damage to the device. Do not remove or install subassembly in test fixture with power applied or damage to equipment may result.

NOTE

Subassemblies shipped in nonapproved containers may be subject to multiple failures due to mishandling.

b. Component Performance Test Table. The component performance tests for the power supply subassembly are contained in table 5-6. Refer to table 5-7 for a listing of test point voltages. Table 5-6 is keyed to fault isolation procedures in table 5-8.

c. Mechanical Assemblies. NOT APPLICABLE

d. Cleaning and Lubrication.

CAUTION

Prior to handling electrostatic-sensitive electronic devices, personnel and equipment must be grounded to prevent static discharge damage to the device.

NOTE

Prefix component reference designators of the SDU power supply subassembly with 1A6.

Clean the subassembly in accordance with TO 00-25-234.



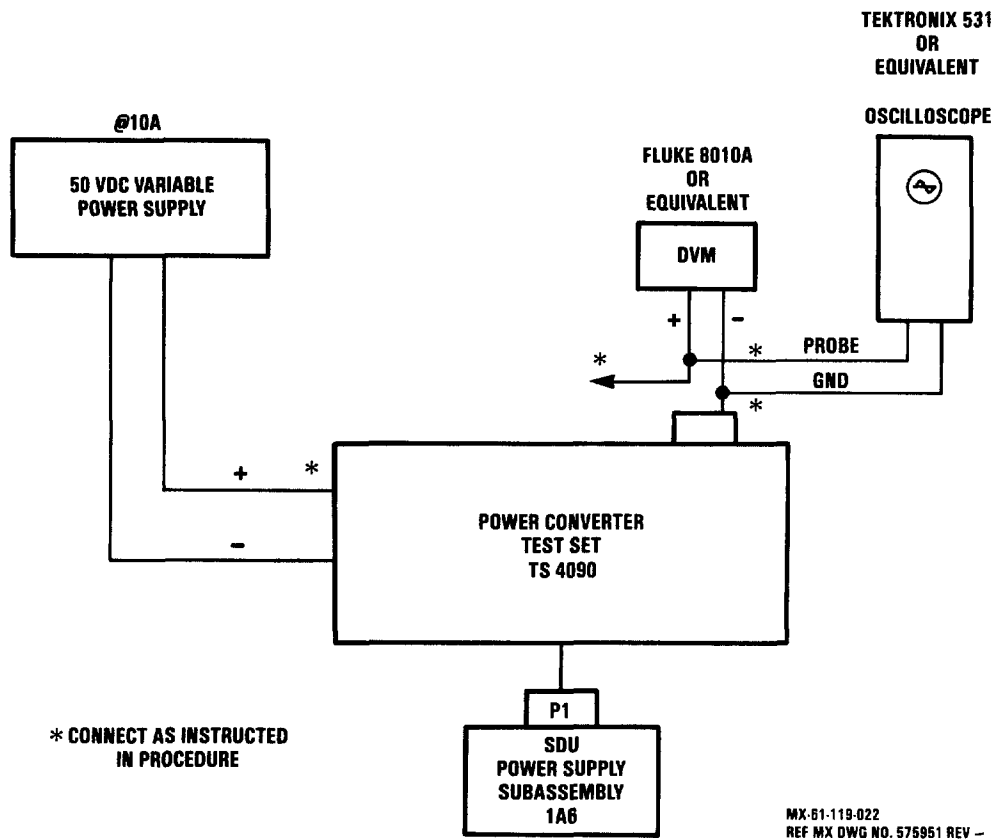

Figure 5-5. SDU Power Supply 1A6 Bench Test Setup

Table 5-6. SDU Power Supply Component Performance Tests

| Step | Connection of test equipment  | Point of test                | Control settings and operation of equipment  | Performance standard   |
|------|---|------------------------------|--|--|
| 1.   |   |                              | <p>Visually inspect power supply for physical damage; i.e., broken or burned parts, lifted or broken traces, corrosion.</p> <p style="text-align: center;"><u>CAUTION</u></p> <p>Set all test equipment switches to the OFF or down position to begin the procedure.</p> | No damage to power supply. Repair as required.                 |
| 2.   | Connect equipment as shown in figure 5-5.                           |                              |  |  |
| 3.   | Connect 50 VDC variable power supply TS4090 leads to VDC INPUT - +. |                              | <p>Turn variable power supply ON and adjust output.</p> <p>Set TS4090 TEST SET CB1 switch to the ON position.</p> <p style="text-align: center;">NOTE</p> <p>Refer to table 5-7 for compilation of test point voltages.</p>  | Test set lamp VDC CR2 lights.                                  |
| 4.   | DVM   | TS4090 TEST SET TP2 and TP1. | Check VDC input.   | +28 VDC.   |
| 5.   | DVM and oscilloscope.   | TP8 and TP11.                |  | <p>+5.00 VDC</p> <p>±0.25 VDC</p> <p>0.2 V p-p ripple max.</p> |

Table 5-6. SDU Power Supply Component Performance Tests - Continued

| Step   | Connection of test equipment | Point of test              | Control settings and operation of equipment                              | Performance standard  |
|--|------------------------------|----------------------------|--|---|
| OUTPUT AND RIPPLE VOLTAGE TESTS  |                              |                            |  |   |
| 6.   |                              |                            | Set DVM scale select switch to 50 VDC range.                             |   |
| 7.   |                              |                            | Vary input voltage on variable power supply between +22 VDC and +30 VDC. | DVM indicates +5.00 $\pm$ 0.25 VDC. Oscilloscope displays ripple voltage of 0.200 max.; width of switching spikes less than 3 microseconds. Input current of 3 A or less in an unchanged condition. |
| <u>CAUTION</u>   |                              |                            |  |   |
| The following step reads a negative value. Ensure that test equipment is configured to read negative values or damage may result to the equipment. |                              |                            |  |   |
| 8.   | DVM                          | TP13 and TP11 on test set. | Vary input voltage on variable power supply between +22 and +30 VDC.     | DVM indicates -29.0 $\pm$ 1.5 VDC. Oscilloscope displays ripple voltage of 1.00 max.; width of switching spikes less than 3 microseconds.   |
| 9.   | DVM.                         | TP9 and TP11.              | Vary input voltage on variable power supply between +22 and +30 VDC.     | DVM indicates +17.5 $\pm$ 1.0 VDC. Oscilloscope displays ripple voltage of 0.500 max.; width of switching spikes less than 3/us.  |

Table 5-6. SDU Power Supply Component Performance Tests - Continued

| Step | Connection of test equipment            | Point of test  | Control settings and operation of equipment   | Performance standard   |
|------|---|----------------|---|--|
| 10.  |   |                | Position test set switch S4 to NOM. Vary input Vary input voltage on variable power supply between +22 and +30 VDC. | DVM indicates 17.5 ± 1.0 VDC. Oscilloscope displays ripple voltage same as step 9. Input current increases to 4.0 A.                     |
| 11.  |   |                | Switch S4 to MIN. Vary input voltage on variable power supply between +22 and +30 VDC.                              | DVM indicates +17.5 ± 1.0 VDC. Input current decreases to 3.0 A or less.   |
| 12.  | DVM.                                    | TP12 and TP11. | Vary input voltage on variable power supply between +22 and +30 VDC.  | DVM indicates +12.00 ± 0.24 VDC. Oscilloscope displays ripple voltage of 0.100 max.; width of switching spikes less than 3 microseconds. |
| 13.  | DVM.                                    | TP10 and TP11. | Vary input voltage on variable power supply between +22 and +30 VDC.  | DVM indicates +9.00 ± 0.18 VDC. Oscilloscope displays ripple voltage 0.100 max.; width of switching spikes less than 3 microseconds.     |
| 14.  | Disconnect oscilloscope leads from DVM. |                | INPUT OVERVOLTAGE TEST  |  |
| 15.  | DVM.                                    | TP10.          | Increase input voltage from the variable power supply to greater than +33.99 VDC, but less than +39.01 VDC.         | SDU power supply shuts down; DVM indicates 0 VDC.  |

Table 5-6. SDU Power Supply Component Performance Tests - Continued

| Step | Connection of test equipment | Point of test  | Control settings and operation of equipment   | Performance standard   |
|------|------------------------------|----------------|---|--|
| 16.  |                              |                | Reduce variable power supply input to +28 VDC.  |  |
| 17.  |                              |                | Cycle test set switch CB1 OFF and back ON.  |  |
| 18.  | DVM display.                 |                |   | DVM indicates +9.00 $\pm$ 0.18 VDC; the SDU power supply resumes operation.        |
|      |                              |                | SHORT CIRCUIT TEST  |  |
| 19.  | DVM.                         | TP11 and TP12. | Set test set 17.5 VDC LOAD SHORT CIRCUIT switch S5 to the down position momentarily then release. | SDU power supply must shut down. (DVM indication drops to 0 VDC).                  |
| 20.  | DVM.                         |                | Cycle test set switch CB1 OFF and back ON.  | DVM indicates 17.5 VDC $\pm$ 1.0 VDC. SDU power supply resumes normal information. |
| 21.  | DVM.                         | TP8 and TP11.  | Set test set 5 VDC LOAD NOMINAL switch S3 to the SHORT CIRCUIT position momentarily and release.  | SDU power supply must shut down. (DVM display drops to 0 VDC).                     |
| 22.  |                              |                | Cycle test set switch CB1 OFF and back ON.  | DVM indicates 5 VDC $\pm$ 0.25 VDC. SDU power supply resumes normal operation.     |
| 23.  |                              |                | Test is completed. Remove power.  |  |

Table 5-7. SDU Power Supply Performance Test Voltages

| Test point location   | Condition  | Results   |
|---|--|---|
| INPUT VOLTAGES  |  |   |
| TP2 and TP1<br>TP8 and TP11                                     | CB1 ON<br>CB1 ON   | +28 VDC input<br>+5 ± 0.25 VDC                                      |
| OUTPUT AND RIPPLE VOLTAGE TEST                                  |  |   |
| TP13 and TP11<br>TP9 and TP11<br>TP12 and TP11<br>TP10 and TP11 | CB1 ON<br>CB1 ON<br>CB1 ON<br>CB1 ON   | -29.0 ± 1.5 VDC<br>+17.5 ± 1 VDC<br>+12 ± 0.24 VDC<br>+9 ± 0.18 VDC |
| INPUT OVERVOLTAGE TEST  |  |   |
| TP10 and TP11   | Increase power supply to greater than +33.99 VDC.<br><br>Reduce power supply voltage to +28 VDC. Switch CB1 OFF then ON. | 0 VDC   |
| SHORT CIRCUIT TEST  |  |   |
| TP12 and TP11   | S5 momentarily down then release.  | 0 VDC   |
| TP8 and TP11  | S3 to SHORT CIRCUIT.   | 0 VDC   |
|   | Switch CB1 OFF then ON.  | +5 ± 0.25 VDC   |

Table 5-8. SDU Power Supply Fault Isolation Tests

| Step | Procedure   | Normal indication   | Fault location  |
|------|---|---|---|
| 1.   | <p style="text-align: center;">OUTPUT AND RIPPLE VOLTAGE TEST</p> <p>Connect equipment as described in table 5-6, steps 1 through 7.</p> <p style="text-align: center;"><u>CAUTION</u></p> <p>The following step reads a negative value. Ensure that test equipment is configured to read negative values, or damage to equipment may result.</p> <p style="text-align: center;">NOTE</p> <p>Refer to table 5-9 for a compilation of test point voltages.</p> | <p>DVM indicates +5.00 ± 0.26 VDC</p> <p>Oscilloscope displays ripple voltage of 0.200 max. Width of switching spikes less than 3 micro-seconds.</p> <p>Input current of 3 A or less in an unchanged condition.</p> | <p>DVM indicates incorrect voltage: U1, UR4, L3, R26, U3 or associated circuitry, Q2, Q3, Q4, or Q6.</p> <p>Ripple voltage greater than 0.200: L1, C1, or R46.</p> <p>Switching spikes more than 3 micro-seconds: U3 or associated circuitry.</p> <p>Ammeter indicates greater than 3 A: Q1 or associated circuitry, Q6, R44, or C22.</p> |

Table 5-8. SDU Power Supply Fault Isolation Tests - Continued

| Step | Procedure   | Normal indication   | Fault location  |
|------|---|---|---|
| 2.   | Connect leads of DVM to TP11 and TP13 of SDU test set. Vary input voltage on variable power supply between +22 and +30 VDC. | <p>DVM indicates <math>-29.0 \pm 1.5</math> VDC.</p> <p>Oscilloscope displays ripple voltage of 1.00 max.</p> <p>Switching spikes less than 3 microseconds.</p>           | <p>DVM indicates incorrect voltage: U1, L3, CR3, R36, or R25.</p> <p>Ripple voltage greater than 1.00: R36, C10.</p> <p>Switching spikes more than 3 microseconds in width: U3 or associated circuitry.</p>   |
| 3.   | Connect leads of DVM to TP9 and TP11 of SDU test set.   |   |   |
| 4.   | Vary input voltage on variable power supply between +22 and +30 VDC.  | <p>DVM indicates <math>+17.5 \pm 1.0</math> VDC.</p> <p>Oscilloscope displays ripple voltage of 0.500 max.</p> <p>Switching spikes less than 3 microseconds in width.</p> | <p>DVM indicates incorrect voltage: U4, VR5, L2, R37, U2 or associated circuitry, Q2, Q3, Q4, or Q6.</p> <p>Ripple voltage greater than 0.500: L2, C13, C25.</p> <p>Switching spikes more than 3 microseconds in width: U2 or associated circuitry.</p> |
| 5.   | Position test set switch S4 to NOM. Vary input voltage power supply between +22 and +30 VDC.                                | Oscilloscope displays ripple voltage of 0.500 max. Input current increases to 4.0 A.  | Abnormal indication: L2, C13, or C25.   |



Table 5-8. SDU Power Supply Fault Isolation Tests - Continued

| Step | Procedure  | Normal indication  | Fault location  |
|------|--|--|---|
| 6.   | Switch S4 to MIN. Vary input voltage on variable power supply between +22 and +30 VDC. |  |   |
| 7.   | Connect leads of DVM to TP11 and TP12 of SDU test set.                                 |  |   |
| 8.   | Vary input voltage on variable power supply between +22 and +30 VDC.                   | <p>DVM indicates +12.00 <math>\pm</math> 0.24 VDC.</p> <p>Oscilloscope displays ripple voltage of 0.100 max.</p> <p>Switching spikes less than 3 microseconds.</p> | <p>DVM indicates incorrect voltage; ensure correct +17.5 VDC supply, step 5: U6 or associated circuitry.</p> <p>Ripple voltage greater than 0.100: C19 or C27.</p> <p>Width of switching spikes more than 3 microseconds: step 5.</p> |
| 9.   | Connect leads of DVM to TP10 and TP11 of SDU test set.                                 |  |   |
| 10.  | Vary input voltage on variable power supply between +22 and +30 VDC.                   | <p>DVM indicates +9.00 <math>\pm</math> 0.18 VDC.</p> <p>Oscilloscope displays ripple voltage of 0.100 max.</p> <p>Switching spikes less than 3 microseconds.</p>  | <p>DVM indicates incorrect voltage; ensure correct +17.5 VDC supply, step 5: U5 or associated circuitry.</p> <p>Ripple voltage greater than 0.100: C16.</p> <p>Width of Switching spikes more than 3 microseconds: step 5.</p>        |

Table 5-8. SDU Power Supply Fault Isolation Tests - Continued

| Step                   | Procedure  | Normal indication  | Fault location  |
|------------------------|--|--|---|
| INPUT OVERVOLTAGE TEST |  |  |   |
| 11.                    | Increase input voltage from variable power supply to greater than +33.99 VDC, but less than +39.01 VDC.                                | SDU power supply shuts down; DVM indicates 0 VDC.                                | SDU power supply fails to shut down: VR1, Q2, Q3, Q4, or associated circuitry.        |
| 12.                    | Reduce variable power supply input to +28 VDC.   |  |   |
| 13.                    | Cycle test set switch CB1 OFF and back ON.   | DVM indicates +9.00 $\pm$ 0.18 VDC; SDU power supply resumes operation.          | SDU power supply fails to resume operation: VR1, Q2, Q3, Q4, or associated circuitry. |
| SHORT CIRCUIT TEST     |  |  |   |
| 14.                    | Connect leads of DVM to TP11 and TP12 of test set.   |  |   |
| 15.                    | Set test set 17.5 VDC LOAD SHORT CIRCUIT switch S5 to the down position momentarily and then release.                                  | SDU power supply must shut down (DVM indication drops to 0 VDC).                 | SDU power supply does not shut down: Q5, Q6, or associated circuitry.                 |
| 16.                    | Cycle test set switch CB1 OFF and back ON.   | DVM indicates 17.5 VDC $\pm$ 1.0 VDC. SDU power supply resumes normal operation. | SDU power supply remains OFF: Q5 or see step 5.                                       |
| 17.                    | Connect leads of DVM to TP8 and TP11. Set test set 5 VDC LOAD NOMINAL switch S3 to the SHORT CIRCUIT position momentarily and release. | SDU power supply must shut down. (DVM display drops to 0 VDC).                   | SDU power supply does not shut down: Q1 or Q6 and associated circuitry.               |

Table 5-8. SDU Power Supply Fault Isolation Tests - Continued

| Step | Procedure                                  | Normal indication  | Fault location                                  |
|------|--|--|---|
| 18.  | Cycle test set switch CB1 OFF and back ON. | SDU power supply resumes normal operation. DVM indicates 5 VDC +/- 0.25 VDC. | SDU power supply remains OFF: Q1 or see step 1. |
| 19.  | Tests are complete.                        |  |   |

e. Repair and Replacement. Repair of the subassembly consists of the removal of malfunctioning components and their replacement with serviceable components. Refer to IPB figure 7-9 for items that are SMR coded for repair at depot level. Upon receipt of a power supply subassembly for repair at depot level, perform the following procedures:

CAUTION

Digital microcircuits U2, U3, U5, U6 are susceptible to electrostatic discharge damage. Prior to handling electrostatic-sensitive electronic devices, personnel and equipment must be grounded to prevent static discharge damage to the device.

- (1) Visually inspect CCA for damage to components or traces from heat, deterioration, moisture, or deposits from oxidation or corrosion.
- (2) Check for broken wires, bent pins, frayed insulation, and poor soldering connections.
- (3) Check printed wiring board for cracks or delamination.
- (4) Replace defective components. Refer to figures 5-6 and 7-9 for component location and orientation. Refer to figure 5-7 for maximum allowable component height.
- (5) Perform all soldering and other electronic maintenance in accordance with TO 00-25-234 per MIL-STD-454, Requirement 5. Use solder Type SN60WRMAP2 per QQ-S-571.
- (6) Install electrical insulation sleeving over the pins of U1 and U4, hybrid semiconductor devices (23, figure 7-9), and U6 and U6 microcircuits (37).
- (7) Except for indicated areas in figure 5-6, cover both sides with conformal coating per MIL-I-46058, Type UR.

f. Reassembly and Testing of Subassemblies and Assemblies. Refer to the above paragraph, Repair and Replacement, for special reassembly instructions of the subassembly.

g. Testing. Perform the instructions contained in table 5-6, SDU Power Supply Component Performance Tests, to ensure the serviceable condition of the subassembly.

Table 5-9. SDU Power Supply Fault Isolation Voltages

| Test point location   | Condition  | Results   |
|---|--|---|
| INPUT VOLTAGES  |  |   |
| TP2 and TP1<br>TP8 and TP11                                     | CB1 ON<br>CB1 ON   | +28 VDC input<br>$+5 \pm 0.25$ VDC  |
| OUTPUT AND RIPPLE VOLTAGE TEST                                  |  |   |
| TP13 and TP11<br>TP9 and TP11<br>TP12 and TP11<br>TP10 and TP11 | CB1 ON<br>CB1 ON<br>CB1 ON<br>CB1 ON   | $-29.0 \pm 1.5$ VDC<br>$+17.5 \pm 1$ VDC<br>$+12 \pm 0.24$ VDC<br>$+9 \pm 0.18$ VDC |
| INPUT OVERVOLTAGE TEST  |  |   |
| TP10 and TP11   | Increase power supply to greater than +33.99 VDC.<br><br>Reduce power supply voltage to +28 VDC. Switch CB1 OFF then ON. | 0 VDC   |
| SHORT CIRCUIT TEST  |  |   |
| TP12 and TP11   | S5 momentarily down then release.  | 0 VDC   |
| TP8 and TP11  | S3 to SHORT CIRCUIT.<br><br>Switch CB1 OFF then ON.  | 0 VDC<br><br>$+5 \pm 0.25$ VDC  |

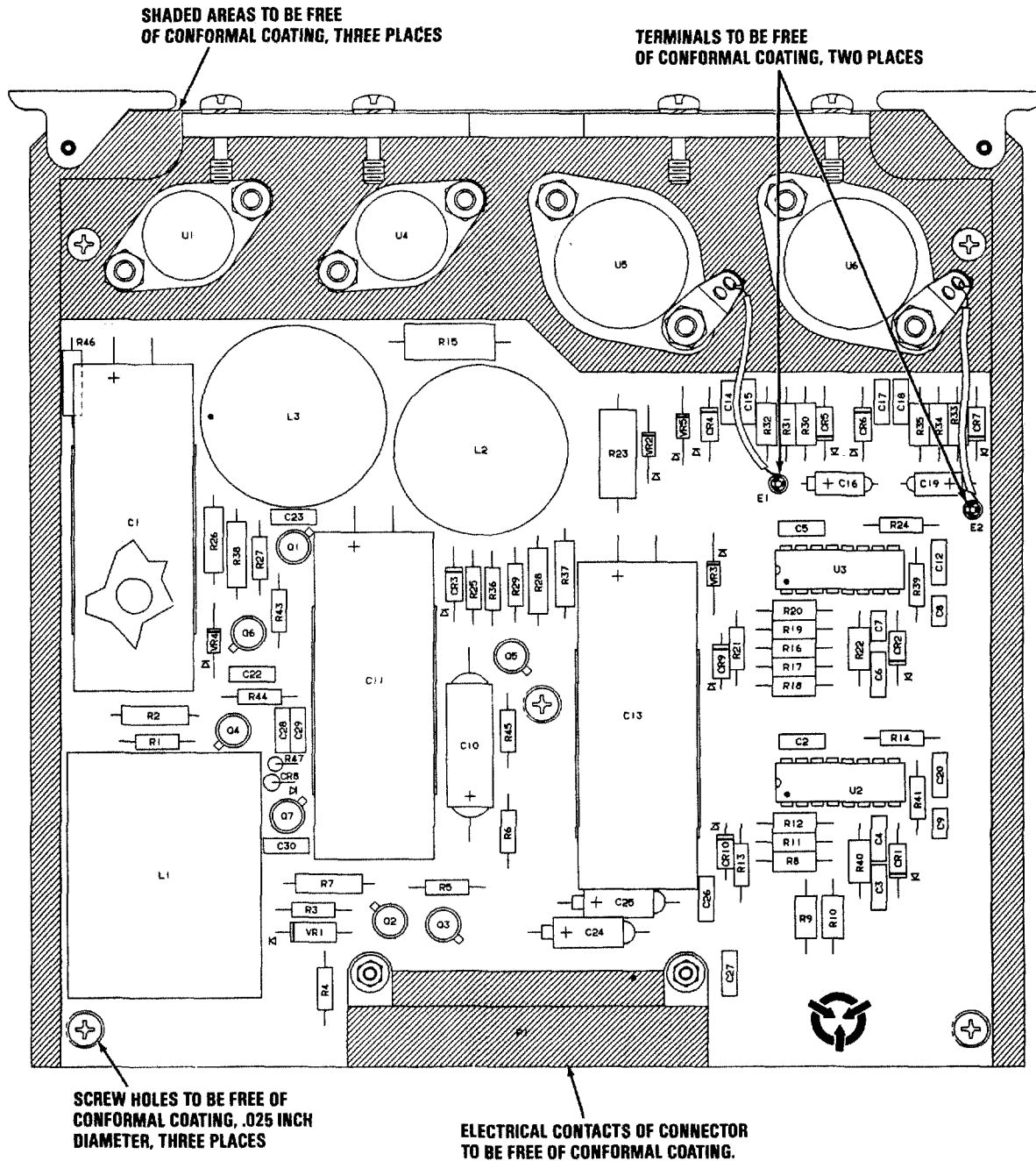

NOTE: REFERENCE DESIGNATIONS ARE ABBREVIATED.  
PREFIX WITH 1A6.

MX-81 118 023  
REF MX DWG NO. 812122 REV J

Figure 5-6. SDU Power Supply 1A6 Component Location

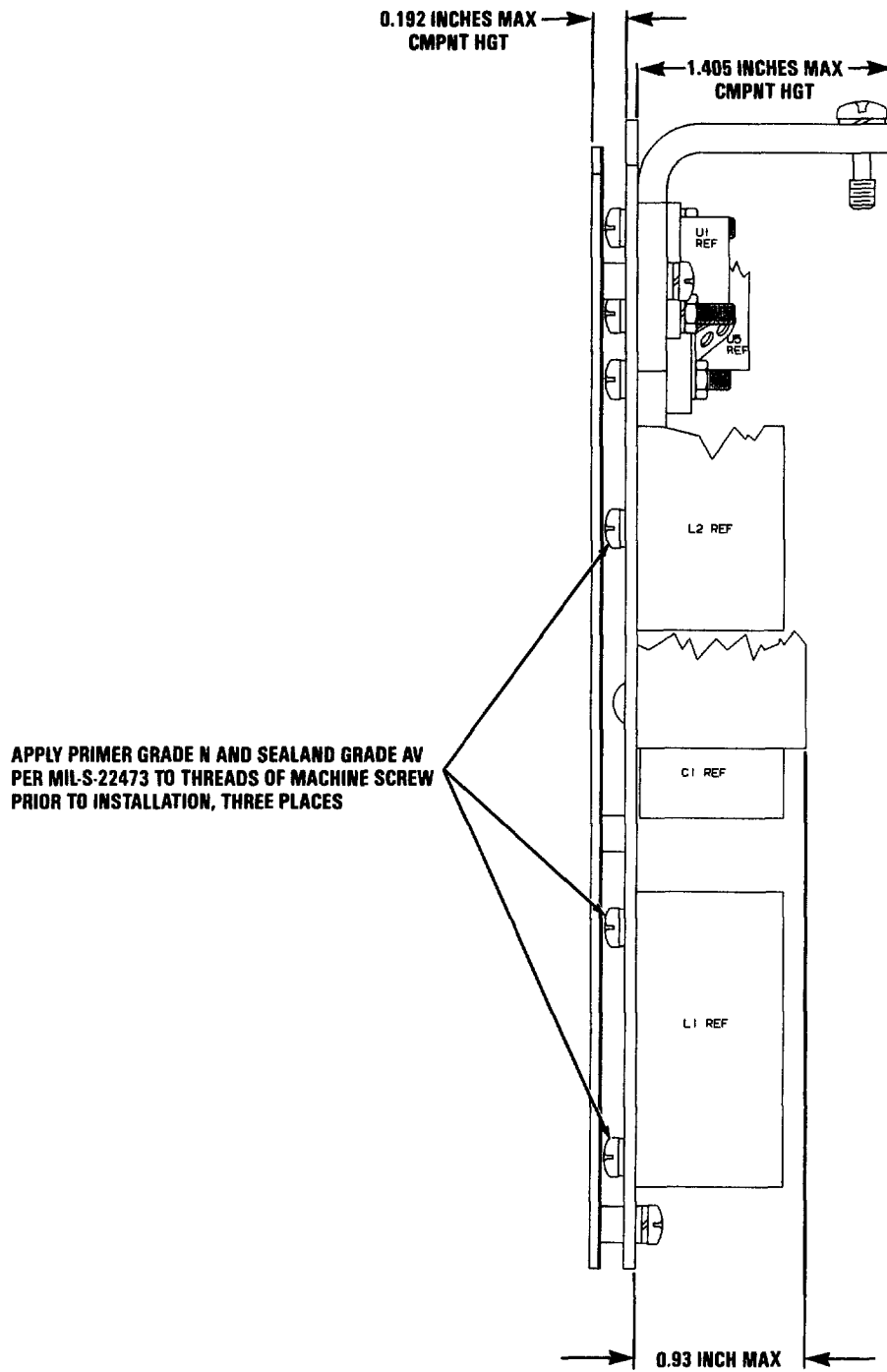

MX-01-119-024  
REF MX DWG NO. 012122 REV J

Figure 5-7. SDU Power Supply 1A6 Component Height

TO 31R2-2GRC206-12

5-7. FIBER OPTIC MODULE ASSEMBLY MAINTENANCE.

Maintenance Instructions to be Determined



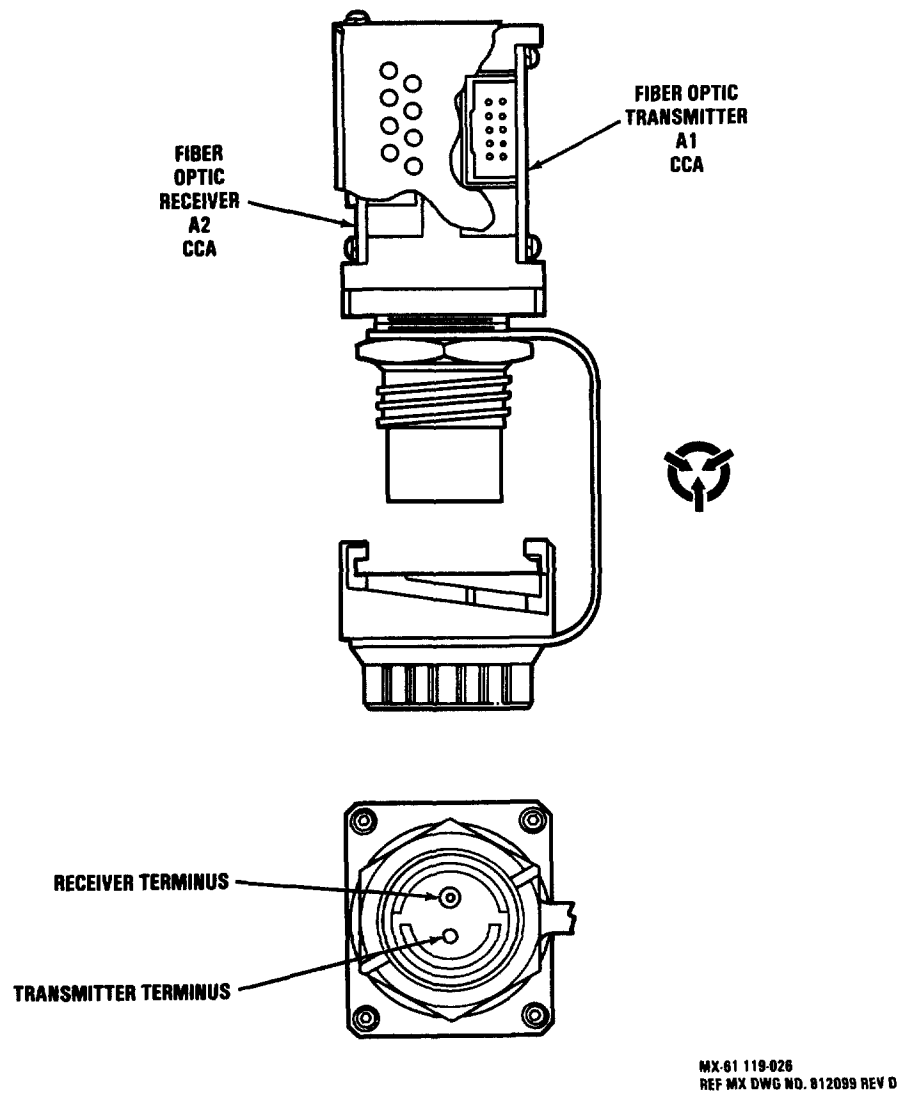

Figure 5-8. Fiber Optic Module 1A8 and 1A9 Component Location

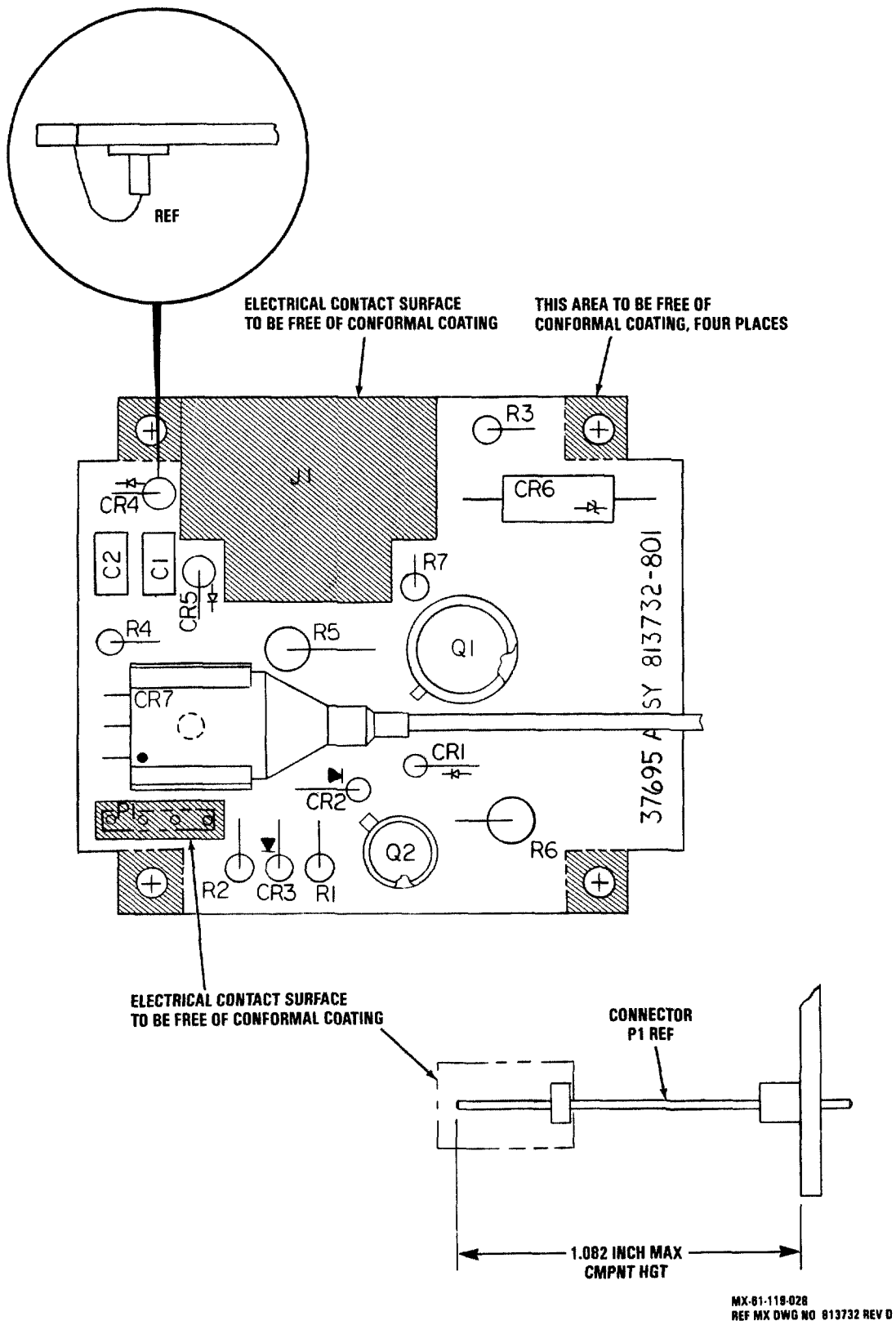

Figure 5-9. Fiber Optic Transmitter CCA 1A8A1 or 1A9A1 Component Location

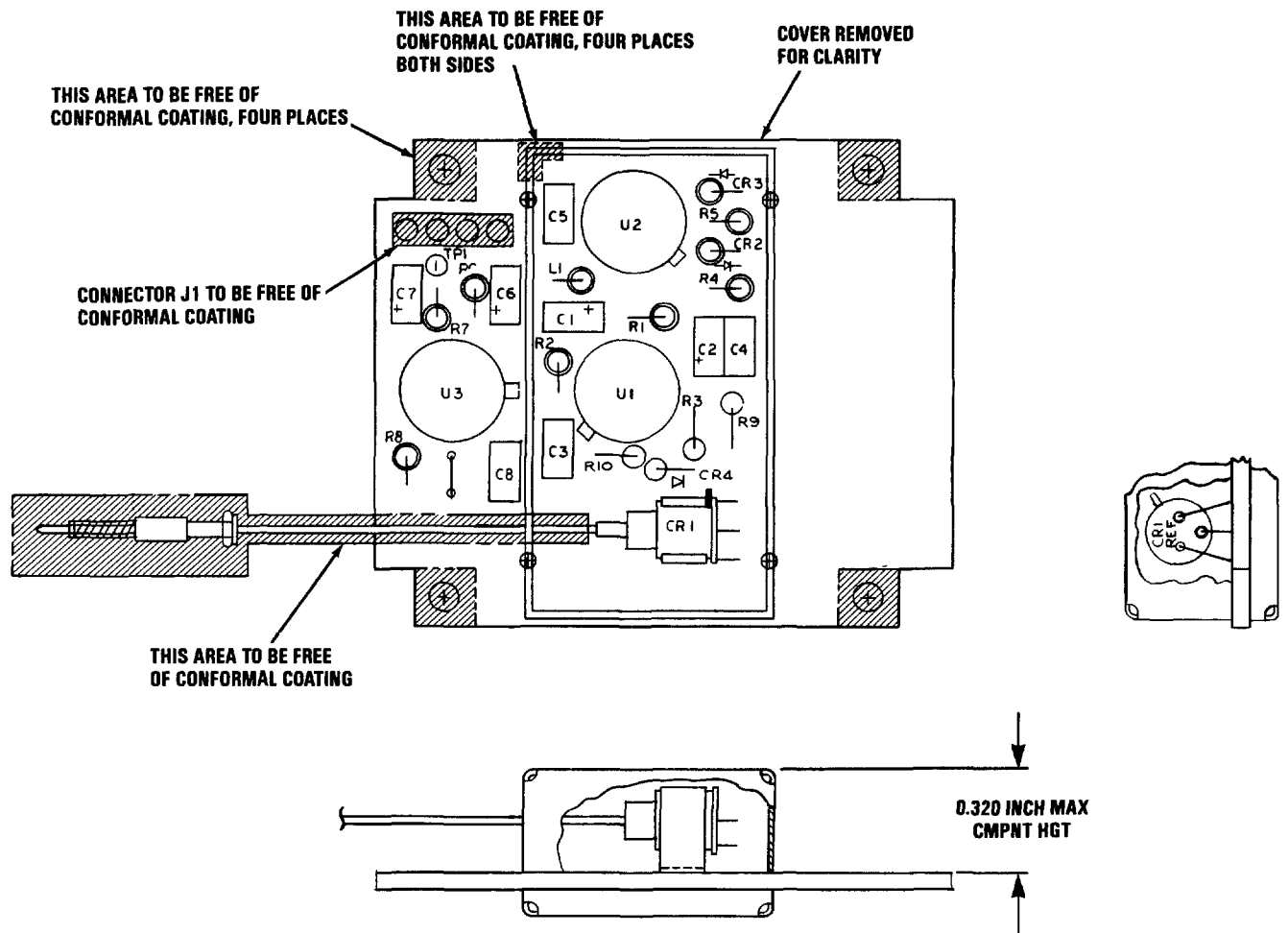

Figure 5-10. Fiber Optic Receiver CCA 1A8A2 or 1A9A2 Component Location

5-8. FIBER OPTIC CABLE ASSEMBLY.

WARNING

Laser radiation is harmful to personnel. Avoid directing laser beams at personnel or aligning the laser with the naked eye. Eye protection for the wavelength frequency and visible light transmission is required.

Do not look into unterminated connectors of fiber optic cables that are connected to the OTDR. Damage to or destruction of eyesight will result.

a. Bench Test Setup. The bench test setup of the fiber optic receiver is illustrated in figure 5-11.

NOTE

Assemblies shipped in nonapproved containers may contain multiple failures due to mishandling.

b. Component Performance Test Table. The performance tests for the fiber optic cable assembly are contained in table 5-10. This table is keyed to fault isolation procedures in table 5-11. Refer to step 5-8.d for cleaning and handling instructions. The fiber optic cable cleaning kit components are listed in table 5-12.

c. Mechanical Assemblies. NOT APPLICABLE

d. Cleaning and Lubrication.

NOTE

The fiber optic cable assembly reference designator is W11.

Clean the fiber optic cable assembly hermaphroditic connectors in accordance with the following steps:

CAUTION

Make all fiber optic cable connections by hand. Do not use tools or damage to equipment may result.

- (1) Refer to figure 5-12 and disconnect the cable (or dust cap) from the optical connector.
- (2) Pull the alignment sleeve from the main body of the connector in a straight motion.

- (3) Using items listed in table 5-12, remove any debris from the connector by brushing. If the connector is too dirty, it may be necessary to wash it with clean, clear water.
- (4) Dry the connector and sleeve with a dry, lint free cloth.
- (5) Apply a few drops of optical cleaner (p/n 3) on lens paper (p/n 73).
- (6) Wipe the ends of the optical terminus with a dampened lens paper.
- (7) Buff the optical terminus, using a circular motion, with the polishing cleaner (p/n 40-7212).
- (8) Inspect the optical terminus with a pocket magnifier (p/n N-8184).
- (9) If lint deposits are found on the face of the optical terminus, peel back the adhesive backing on the buffer pad, and with a rolling motion, press the adhesive back to the lens to remove lint.
- (10) Perform another inspection to insure that all debris has been removed the terminus.
- (11) Inspect alignment sleeve terminus guides and clean if necessary.
- (12) After cleaning and final inspection of the connector, reinstall the sleeve by carefully aligning the terminus guides and tabs of the alignment sleeve with the main body. Push the alignment guide back into the connector.
- (13) Reconnect cables or install dust caps.

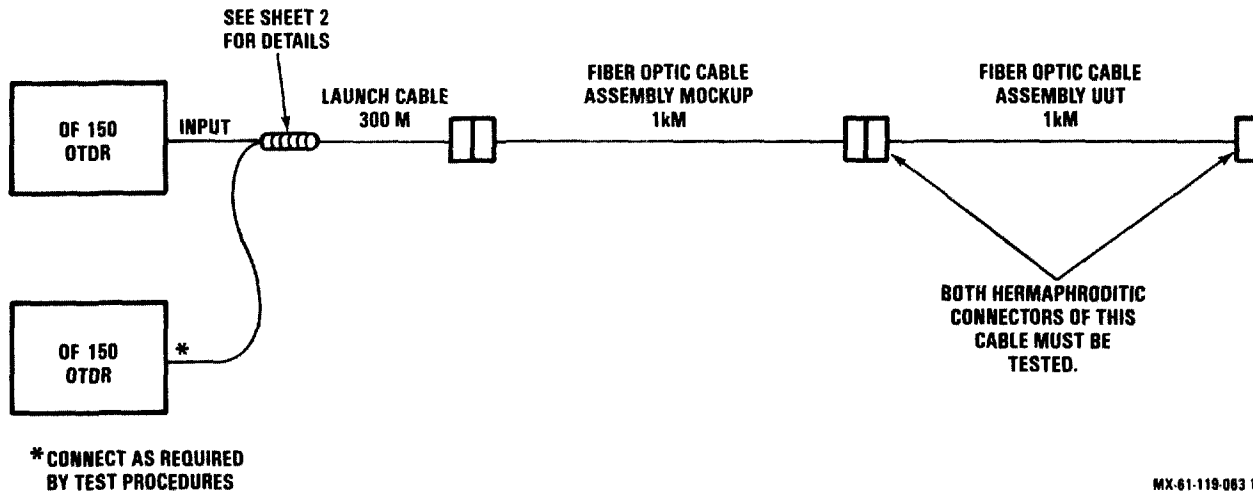

Figure 5-11. Fiber Optic Cable Assembly 1A8 or 1A9 Bench Test Setup (Sheet 1 of 2)

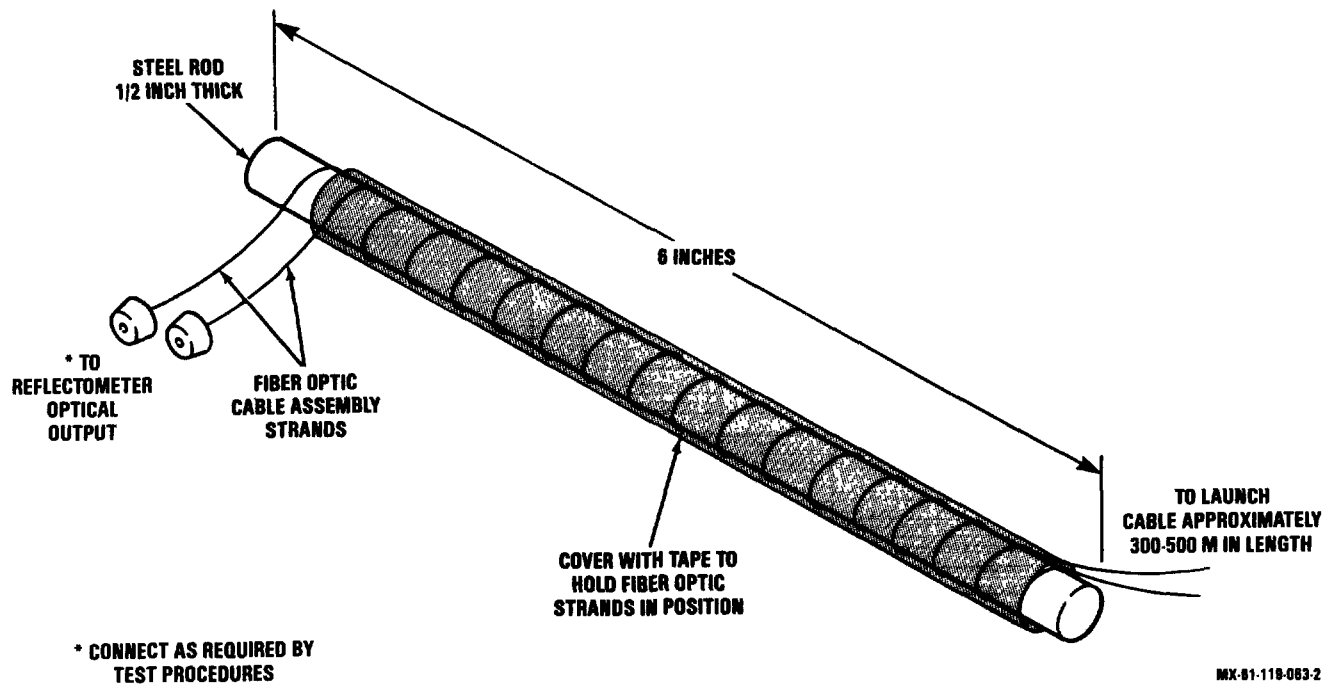

Figure 5-11. Fiber Optic Cable Assembly 1A8 or 1A9 Bench Test Setup  
(Sheet 2 of 2)

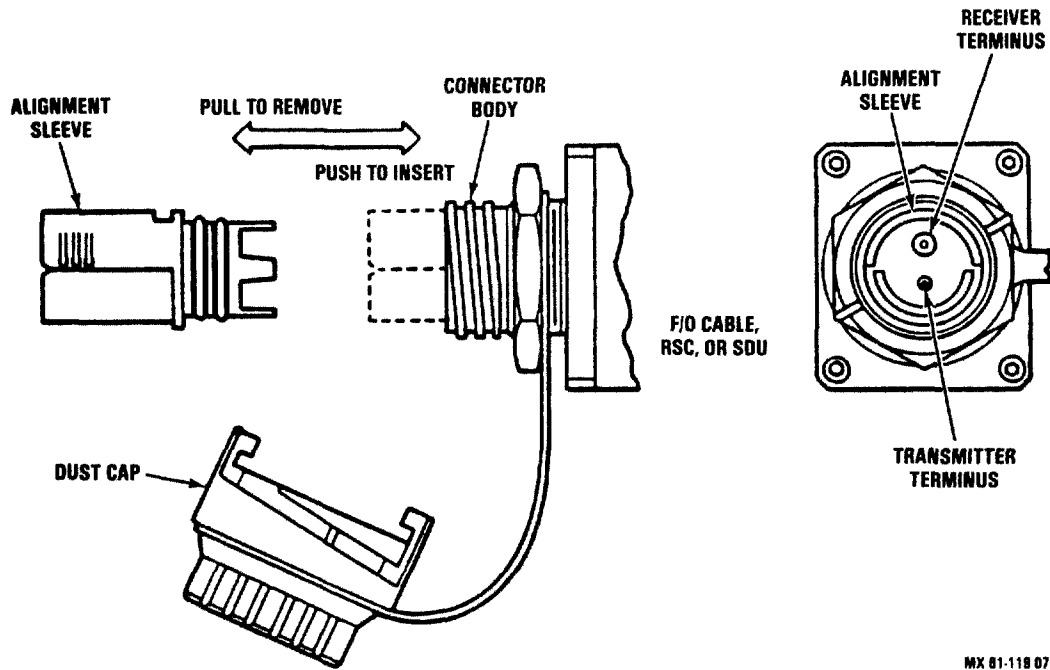

Figure 5-12. Hermaphroditic Connector Components



Table 5-10. Fiber Optic Cable Assembly Performance Tests

| Step | Connection of test equipment  | Point of test | Control settings and operation of equipment   | Performance standard |
|------|---|---------------|---|----------------------|
|      |   |               | <p style="text-align: center;"><u>CAUTION</u></p> <p>Fibers of fiber optic cable are very delicate. Fibers will break if roughly handled.</p> <p>1. Connect test equipment as shown in figure 5-11.</p> <p>2. Strip approximately 12 inches of the 3M launch cable and free two fiber optic fibers.</p> <p>3. Mandrel wrap the two fiber optic fibers eight times around a one half inch thick steel rod approximately six inches long.</p> <p style="text-align: center;">NOTE</p> <p>The launching cable establishes a reference for the reflectometer.</p> |                      |
| 4.   | At one end of the steel rod, terminate each of the two fiber optic strands to OTDR connectors and reflectometer test set OF150. |               |   |                      |

Table 5-10. Fiber Optic Cable Assembly Component Performance Tests - Continued

| Step        | Connection of test equipment                                   | Point of test               | Control settings and operation of equipment   | Performance standard  |
|-------------|--|-----------------------------|---|---|
| 4.<br>cont. |  |                             | NOTE  |   |
|             |  |                             | It is possible to use only one test set OF150 to perform this test. Half of the hermaphroditic connector and one fiber optic strand are tested each time the OTDR takes a reading.                    |   |
| 5.          |  |                             | Refer to figure 5-12.2. If one OTDR is being used, perform steps 5.2 through 7.7. If two OTDR's are being used, perform steps 7.8 through 7.12.   |   |
| 6.          | Connect test equipment as shown in figure 5-12.2 for one ODTR. |                             |   |   |
| 7.          | OF150 reflectometer.   | Herma-phroditic connector.  | Measure cable loss in dB.   | 3dB per connector. Refer to figure 5-12.1. over 3 km. 8dB total                                     |
| 8.          |  | Fiber optic cable assembly. | Measure cable loss in dB.   | 2dB per each 1 km of cable; 8dB total for two connectors and 1 km of cable. Refer to figure 5-12.1. |
| 9.          |  |                             | Refer to figure 5-12.2. Disconnect hermaphroditic connector A of fiber optic cable assembly UUT from the mockup 1 km cable assembly. Connect hermaphroditic connector B to the mockup cable assembly. |   |

Table 5-10. Fiber Optic Cable Assembly Component Performance Tests - Continued

| Step | Connection of test equipment | Point of test               | Control settings and operation of equipment   | Performance standard  |
|------|------------------------------|-----------------------------|---|---|
| 10.  | OF150 reflectometer.         | Hermaphroditic connector.   | Measure connector loss in dB.   | 3dB per connector. Refer to figure 5-12.2.  |
| 11.  |                              | Fiber optic cable assembly. | Measure cable loss in dB.   | 2dB per each 1 km of cable; 8dB total for two connectors and 1 km of cable. Refer to figure 5-12.2  |
| 12.  | OTDR.                        |                             | Change the connection of fiber optic cable assembly connector to OTDR optical output.   |   |
| 13.  | OF150 reflectometer.         | Hermaphroditic connector.   | Measure connector loss in dB  | 3dB per connector. Refer to figure 5-12.1.  |
| 14.  |                              | Fiber optic cable assembly. | Measure cable loss in dB  | 2dB per each 1 km of cable; 8dB total for two connectors and 1 km of cable. Refer to figure 5-12.1. |
| 15.  |                              |                             | Refer to figure 5-12.2. Disconnect hermaphroditic connector B of fiber optic cable assembly UUT from the mockup 1 km cable assembly. Connect hermaphroditic connector A to the mockup cable assembly. |   |
| 16.  | OF150 reflectometer.         | Hermaphroditic connector.   | Measure connector loss in dB  | 3dB per connector. Refer to figure 5-12.1.  |
| 17.  |                              | Fiber optic cable assembly. | Measure cable loss in dB  | 2dB per each 1 km of cable; 8dB total for two connectors and 1 km of cable. Refer to figure 5-12.1. |

Table 5-10. Fiber Optic Cable Assembly Component Performance Tests - Continued

| Step | Connection of test equipment                                    | Point of test               | Control settings and operation of equipment   | Performance standard  |
|------|---|-----------------------------|---|---|
| 18.  | Connect test equipment as shown in figure 5-12.2 for two OTDRs. |                             | The performance test using one OTDR is complete. Refer to table 5-11 for fault isolation tests.   |   |
| 19.  |   |                             | Perform steps 16 and 17 using 1st OTDR, then repeat steps 16 and 17 using 2nd OTDR.   |   |
| 20.  |   |                             | Refer to figure 5-12.2. Disconnect hermaphroditic connector A of fiber optic cable assembly UUT from the mockup 1 km cable assembly. Connect hermaphroditic connector B to the mockup cable assembly. |   |
| 21.  |   |                             | OF150 reflectometer.  |   |
| 22.  |   | Fiber optic cable assembly. | Measure cable loss in dB.   | 2dB per each 1 km of cable; 8dB total for two connectors and 1 km of cable. Refer to figure 5-12.1. |
| 23.  |   |                             | The performance test using two OTDRs is complete. Refer to table 5-11 for fault isolation tests.  |   |
| 24.  |   |                             |   |   |

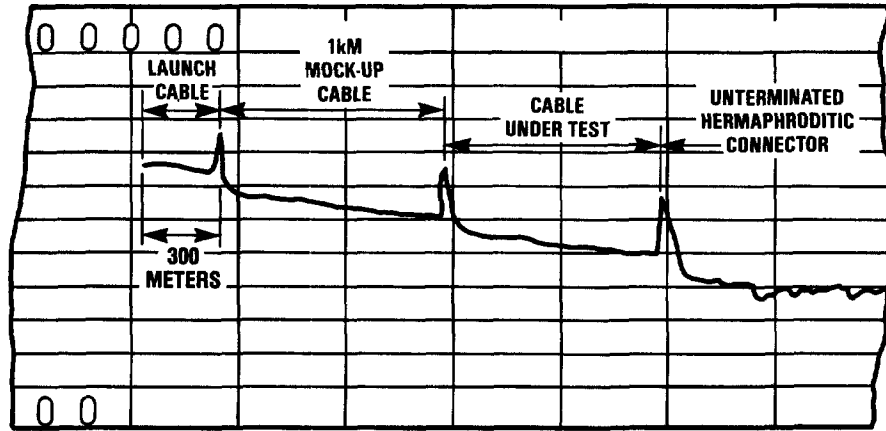

MX 61 118 072

Figure 5-12.1 Fiber Optic Cable Assembly 1A8 or 1A9 OTDR Display

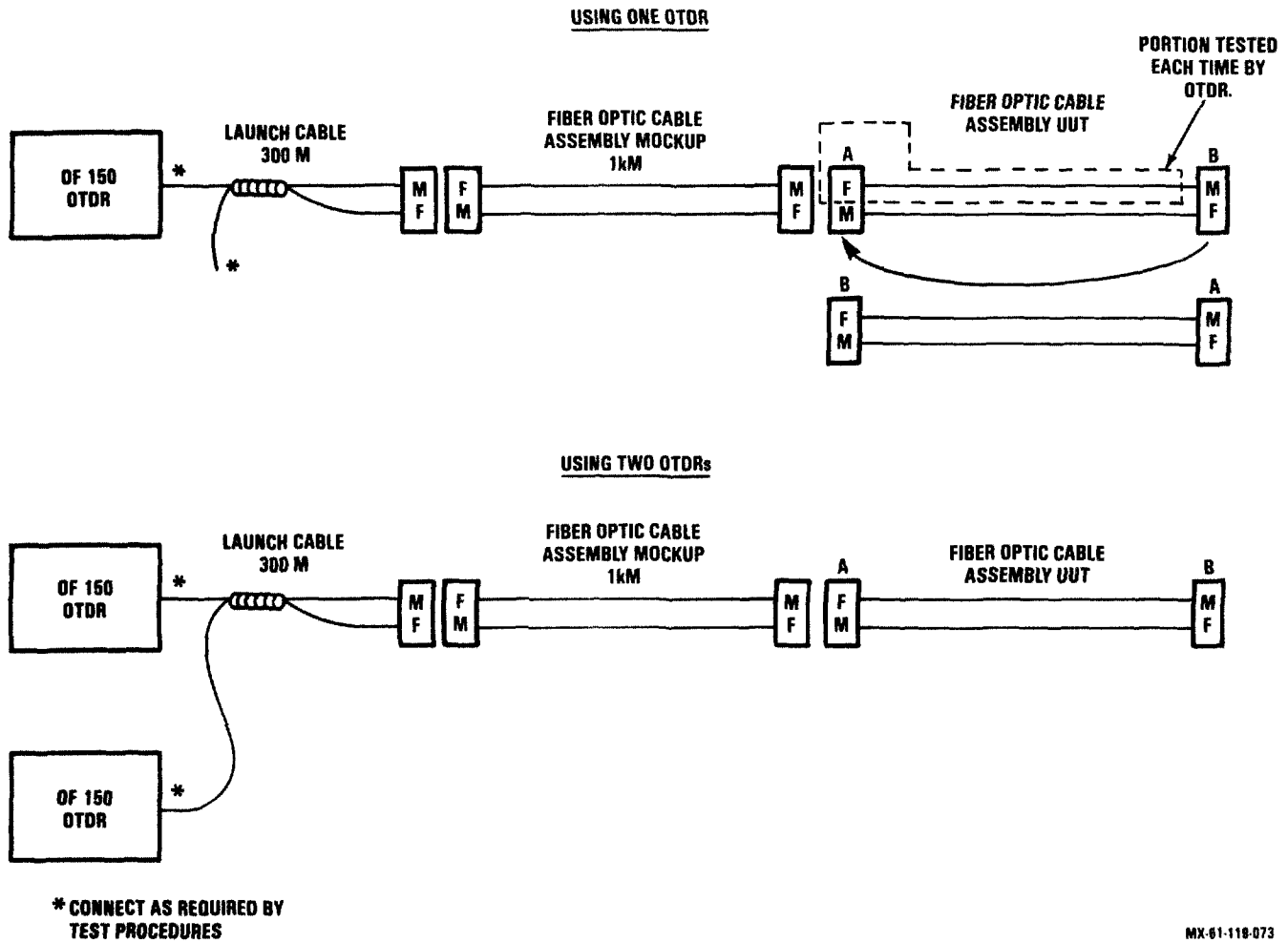

Figure 5-12.2. Single and Dual OTDR Test Setups

Table 5-11. Fiber Optic Cable Assembly Fault Isolation Tests

| Step   | Procedure  | Normal indication   | Fault location              |
|--|--|---|-----------------------------|
| <u>CAUTION</u>   |  |   |                             |
| Fibers of fiber optic cable are very delicate. Fibers will break if roughly handled.   |  |   |                             |
| 1.   | Connect test equipment as shown in figure 5-11.  |   |                             |
| 2.   | Strip approximately 12 inches of the 300M launch cable and free two fiber optic fibers.  |   |                             |
| 3.   | Mandrel wrap the two fiber optic fibers eight times around a one-half inch thick steel rod approximately six inches long.                      |   |                             |
| 4.   | At the end of the steel rod, terminate each of the two fiber optic strands to the OTDR connectors and connect to reflectometer test set OF150. |   |                             |
| <u>NOTE</u>  |  |   |                             |
| It is possible to use only one test set OF150 to perform this test. Half of the hermaphroditic connector and one fiber optic strand are tested each time the OTDR takes a reading. |  |   |                             |
| 5.   | Refer to figure 5-12.1 and measure dB loss of hermaphroditic connector using OTDR.   | 3 dB loss per connector.  | Connector.                  |
| 6.   | Measure dB loss through fiber optic cable assembly using OTDR.   | 2 dB loss per each 1 km of cable; 8 dB total loss for two connectors and 1 km of cable. | Fiber optic cable assembly. |

Table 5-11. Fiber Optic Cable Assembly Fault Isolation Tests - Continued

| Step | Procedure   | Normal indication   | Fault location              |
|------|---|---|-----------------------------|
| 7.   | Refer to figure 5-12.2. If one OTDR is being used, perform steps 8 through 20. If two OTDRs are being used, perform steps 21 through 28.  |   |                             |
| 8.   | Connect equipment as shown in figure 5-12.2 for one OTDR.   |   |                             |
| 9.   | Refer to figure 5-12.1 and measure dB loss of hermaphroditic connector using OTDR.  | 3 dB loss per connector.  | Connector.                  |
| 10.  | Measure dB loss through fiber optic cable assembly using OTDR.  | 2 dB loss per each 1 km of cable; 8 dB total loss for two connectors and 1 km of cable. | Fiber optic cable assembly. |
| 11.  | Refer to figure 5-12.2. Disconnect hermaphroditic connector A of fiber optic cable assembly UUT from the mock-up 1 km cable assembly. Connect hermaphroditic connector B to the mock-up cable assembly. |   |                             |
| 12.  | Refer to figure 5-12.1 and measure dB loss of hermaphroditic connector using OTDR.  | 3 dB loss per connector.  | Connector.                  |
| 13.  | Measure dB loss through fiber optic cable assembly using OTDR.  | 2 dB loss per each 1 km of cable; 8 dB total loss for two connectors and 1 km of cable. | Fiber optic cable assembly. |
| 14.  | Change the connection of the fiber optic cable assembly connectors to OTDR optical output.  |   |                             |



Table 5-11. Fiber Optic Cable Assembly Fault Isolation Tests - Continued

| Step | Procedure   | Normal indication   | Fault location              |
|------|---|---|-----------------------------|
| 15.  | Refer to figure 5-12.1 and measure dB loss of hermaphroditic connector using OTDR.  | 3 dB loss per connector.  | Connector.                  |
| 16.  | Measure dB loss through fiber optic cable assembly using OTDR.  | 2 dB loss per each 1 km of cable; 8 dB total loss for two connectors and 1 km of cable. | Fiber optic cable assembly. |
| 17.  | Refer to figure 5-12.2. Disconnect hermaphroditic connector B of fiber optic cable assembly UUT from the mock-up 1 km cable assembly. Connect hermaphroditic connector A to the mock-up cable assembly. |   |                             |
| 18.  | Refer to figure 5-12.1 and measure dB loss of hermaphroditic connector using OTDR.  | 3 dB loss per connector.  | Connector.                  |
| 19.  | Measure dB loss through fiber optic cable assembly using OTDR.  | 2 dB loss per each 1 km of cable; 8 dB total loss for two connectors and 1 km of cable. | Fiber optic cable assembly. |
| 20.  | The fault isolation test using one OTDR is complete.  |   |                             |
| 21.  | Connect test equipment as shown in figure 5-12.2 for two OTDRs.   |   |                             |
| 22.  | Refer to figure 5-12.1 and measure dB loss of hermaphroditic connector using OTDR.  | 3 dB loss per connector.  | Connector.                  |
| 23.  | Measure dB loss through fiber optic cable assembly using OTDR.  | 2 dB loss per each 1 km of cable; 8 dB total loss for two connectors and 1 km of cable. | Fiber optic cable assembly. |

Table 5-11. Fiber Optic Cable Assembly Fault Isolation Tests - Continued

| Step | Procedure   | Normal indication   | Fault location              |
|------|---|---|-----------------------------|
| 24.  | Perform steps 22 and 23 using 1st OTDR, then repeat steps 22 and 23 using 2nd OTDR.   |   |                             |
| 25.  | Refer to figure 5-12.2. Disconnect hermaphroditic connector A of fiber optic cable assembly UUT from the mock-up 1 km cable assembly. Connect hermaphroditic connector B to the mock-up cable assembly. |   |                             |
| 26.  | Refer to figure 5-12.1 and measure dB loss of hermaphroditic connector using OTDR.  | 3 dB loss per connector.  | Connector.                  |
| 27.  | Measure dB loss through fiber optic cable assembly using OTDR.  | 2 dB loss per each 1 km of cable; 8 dB total loss for two connectors and 1 km of cable. | Fiber optic cable assembly. |
| 28.  | The performance test using two OTDRs is complete.   |   |                             |

Table 5-12. Fiber Optic Cable Cleaning Kit (P/N 741889-801)

| Part number | Description        | Purpose                           |
|-------------|--------------------|-----------------------------------|
| 40-7212     | Polishing Cleaner  | Burnishes terminus lens           |
| 3           | Optical Cleaner    | Removes minor dirt and oils       |
| 73          | Lens Paper         | Lint free cleaning paper          |
| 8564        | Cleaning Dispenser |                                   |
| N-8184      | Magnifying Glass   | Used to inspect lens and terminus |

e. Repair and Replacement. Repair of the fiber optic cable assembly consists of the removal of malfunctioning components and their replacement with serviceable components. Refer to IPB figure 7-1 for items that are SMR coded for repair at depot level.

f. Reassembly and Testing of Subassemblies and Assemblies. Refer to the above paragraph, Repair and Replacement, for special reassembly instructions of the fiber optic cable assembly.

g. Testing. Perform the instructions contained in table 5-13.1, Fiber Optic Cable Assembly Component Performance Tests, to ensure the serviceable condition of the assembly.

## 5-9. RADIO SET CONTROL.

a. Bench Test Setup. The bench test setup of the radio set control is illustrated in figure 5-13.

CAUTION

Prior to handling electrostatic-sensitive electronic devices, personnel and equipment must be grounded to prevent static discharge damage to the device. Do not remove or install subassembly in test fixture with power applied or damage to equipment may result.

NOTE

Subassemblies shipped in nonapproved containers may be subject to multiple failures due to mishandling.

- (1) Open top cover and swing up the two hinged bracket assemblies (2).
- (2) Remove bracket assembly 941095-801 and plate assembly 515824-801 from inside the test set.
- (3) Remove cable assemblies W2 and W3 from inside the test set.
- (4) Close top cover and tighten two turnlock fasteners (3).
- (5) Attach two hinged bracket assemblies (2) to top cover using turnlock fasteners (4) (two on each assembly).
- (6) Attach bracket and plate assemblies together using two thumbscrews (5).
- (7) Attach bracket plate assembly to the left, front side of test set using three thumbscrews (6).
- (8) Attach panel assembly to bracket/plate assembly using three (captive) crosshead screws (7).
- (9) Attach digital interface assembly (PN 812126-801) to the left hinged bracket assembly (2) using six crosshead screws (8).
- (10) Attach audio interface assembly (PN 812133-801) to the right hinged bracket assembly (2) using six crosshead screws (9).

b. Component Performance Test Table. The component performance tests for the RSC are contained in table 5-13. This table is keyed to fault isolation procedures in table 5-14. These tables also include the performance and fault isolation tests for the RSC audio and digital interface CCAs and the RSC regulator.

c. Mechanical Assemblies. NOT APPLICABLE

d. Cleaning and Lubrication.

CAUTION

Prior to handling electrostatic-sensitive electronic devices, personnel and equipment must be grounded to prevent static discharge damage to the device.

NOTE

Prefix component reference designators of the RSC with 5A2 or 6A2.

Clean the RSC in accordance with TO 00-25-234.

e. Repair and Replacement. Repair of the RSC consists of the removal of malfunctioning components and their replacement with serviceable components. Refer to IPB figure 7-18 for items that are SMR coded for repair at depot level. Upon receipt of an RSC for repair at depot level, perform the following procedures:

CAUTION

CCA A1 is susceptible to electrostatic discharge damage. Prior to handling electrostatic-sensitive electronic devices, personnel and equipment must be grounded to prevent static discharge damage to the device.

- (1) Visually inspect wiring and CCAs for damage to components or traces from heat, deterioration, moisture, or deposits from oxidation or corrosion.
- (2) Check for broken wires, bent pins, frayed insulation, and poor soldering connections.
- (3) Check printed wiring board for cracks or delamination.
- (4) Replace defective components. Refer to figures 5-14 and 7-18 for component location and orientation..
- (5) Perform all soldering and other electronic maintenance in accordance with TO 00-25-234 per MIL-STD-454, Requirement 5. Use solder Type SN60WRMAP2 per QQ-S-571.

(6) Apply a thin film of grease per MIL-G-4343 to O-ring on switches (4 and 15, figure 7-18).

f. Reassembly and Testing of Subassemblies and Assemblies. Refer to the above paragraph, Repair and Replacement, for special reassembly instructions of the RSC.

g. Testing. Perform the instructions contained in table 5-13, RSC CCAs Performance Tests, to ensure the serviceable condition of the subassembly.

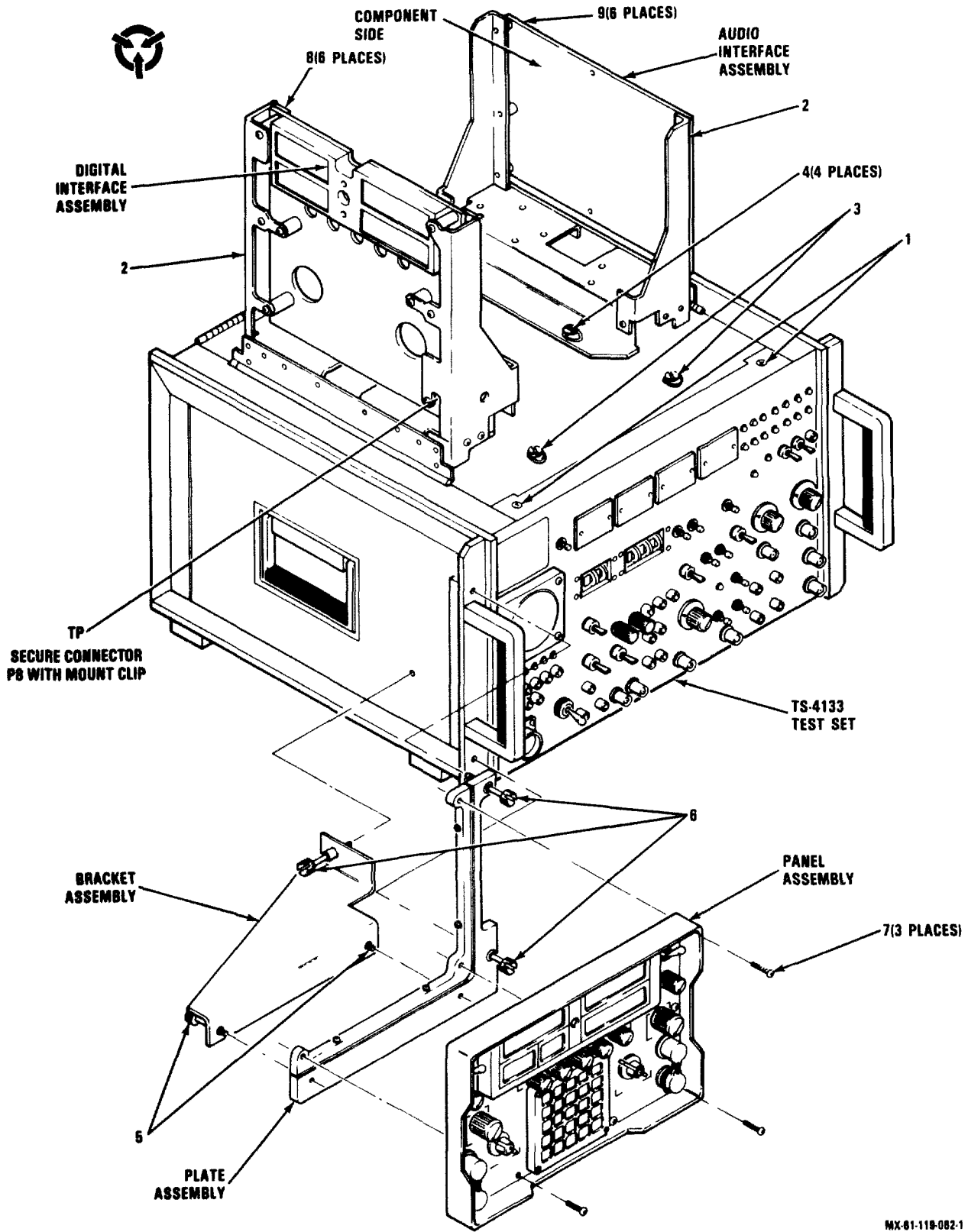

MX-61-119-002-1

Figure 5-13. RSC CCAs Bench Test Setup (Sheet 1 of 2)



\* CONNECT AS REQUIRED

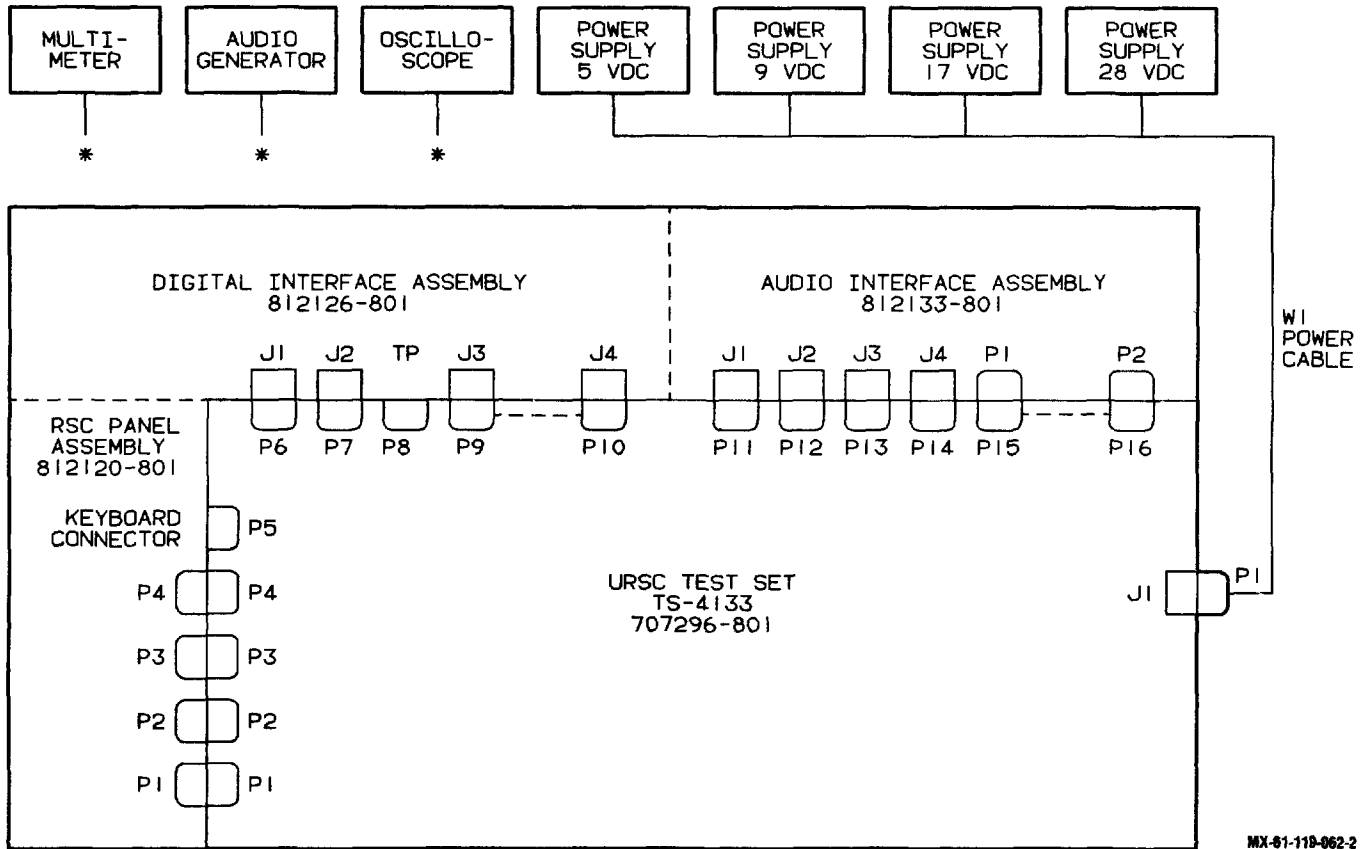

MX-61-119-062-2

Figure 5-13. RSC CCAs Bench Test Setup (Sheet 2 of 2)

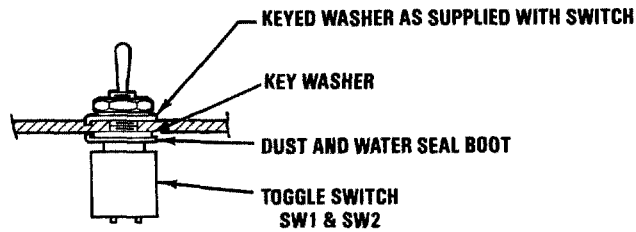
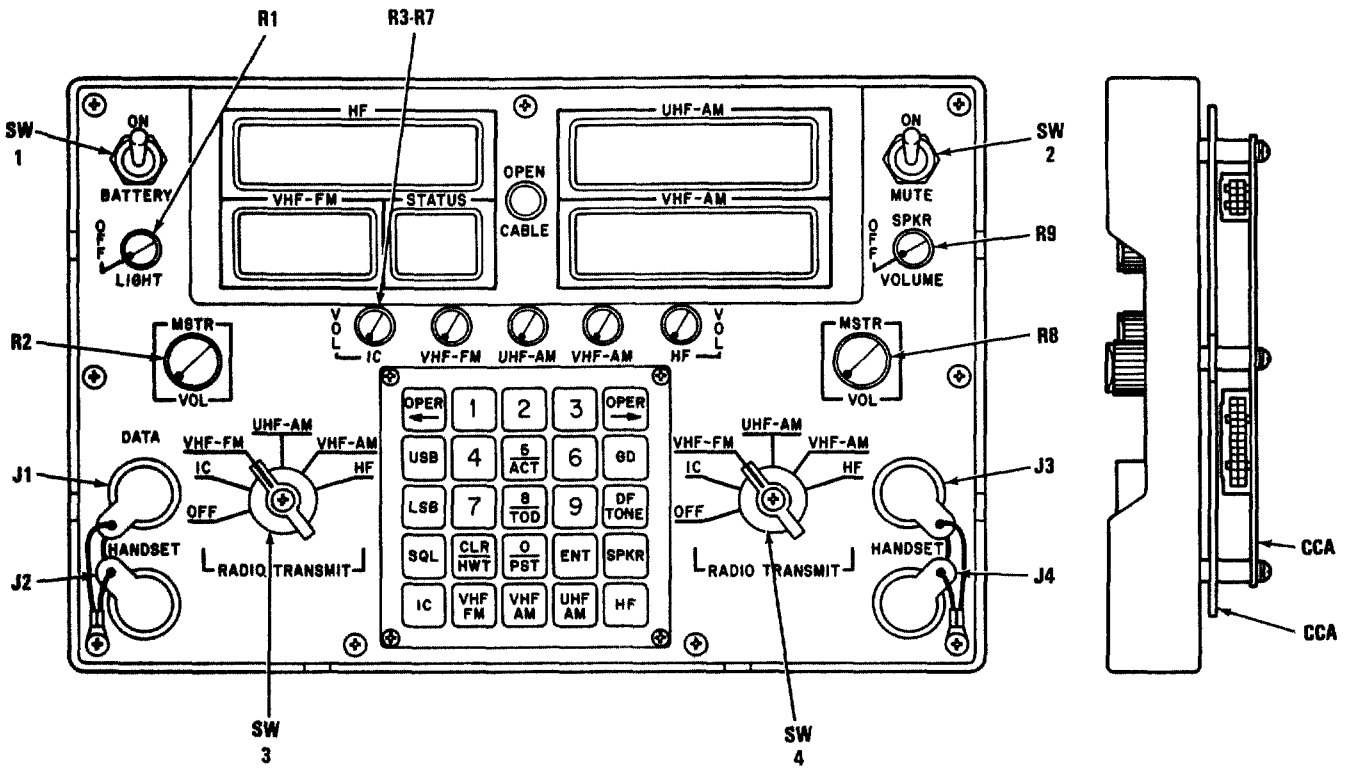

MX-81-118-031-1  
REF MX DWG NO. 812120 REV H

Figure 5-14. Radio Set Control Component Location (Sheet 1 of 2)

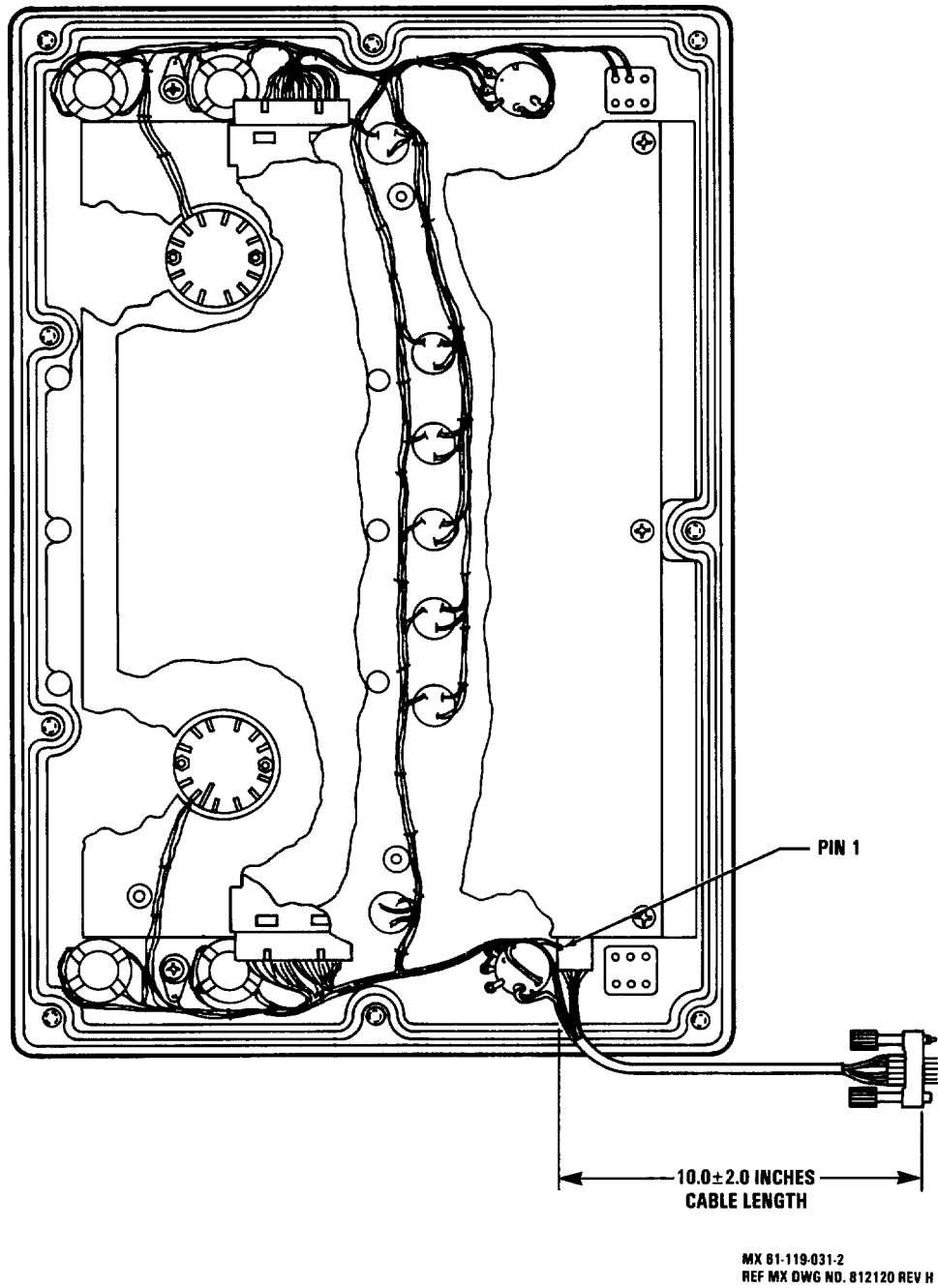

Figure 5-14. Radio Set Control Component Location (Sheet 2 of 2)

Table 5-13. RSC CCAs Performance Tests

| Step | Connection of test equipment                          | Point of test | Control settings and operation of equipment   | Performance standard   |
|------|---|---------------|---|--|
| 1.   |   |               | <p style="text-align: center;">NOTE</p> <p>Switches, indicators, and test point references are on the URSC test set TS4133 unless otherwise noted. Set all switches to OFF or down to begin procedure.</p> <p>Visually inspect the RSC audio and digital interface CCAs for physical damage or corrosion.</p> | <p style="text-align: center;">NOTE</p> <p>Ignore status of all indicators that are not listed.</p> <p>No corrosion or damage to CCAs.</p> |
| 2.   | Connect test equipment as shown in figure 5-13.       |               | <p style="text-align: center;">EQUIPMENT SETUP</p> <p>Adjust power supplies for desired voltages.</p>   |  |
| 3.   | Jumper the common grounds together on power supplies. |               |   |  |
| 4.   | TS4133.   |               | <p>Set switches as follows:</p> <p>S1                   down</p> <p>(DATA MODE)</p> <p>S11 URSC           OFF</p> <p>S12 TEST SET       OFF</p> <p>(POWER SOURCE)</p> <p>S13                   SDU</p>  |  |

Table 5-13. RSC CCAs Performance Tests - Continued

| Step        | Connection of test equipment | Point of test | Control settings and operation of equipment   | Performance standard   |
|-------------|------------------------------|---------------|---|------------------------|
| 4.<br>cont. |                              |               | (SPEAKER)<br><br>S14 OUTPUT            SPEAKER<br>LOAD/SPEAKER<br><br>(RETRANSMIT)<br><br>S19 AUTO START      OFF<br><br>(TEST SET AUDIO)<br><br>S24 TRANSMIT        OFF<br>SELECT<br><br>S25 RECEIVE         OFF<br>SELECT<br><br>(SERIAL DATA IN<br>VOLTAGE ADJUST)<br><br>R1 UPPER MAX CCW<br>R2 LOWER MAX CCW |                        |
| 5.          |                              |               | On the RSC front panel:<br><br>R1 LIGHT max CCW<br>R2 VOL max CCW   |                        |
| 6.          |                              |               | Set S1 to the ON position.  | CR1 through CR4 light. |

Table 5-13. RSC CCAs Performance Tests - Continued

| Step | Connection of test equipment | Point of test  | Control settings and operation of equipment  | Performance standard  |
|------|------------------------------|--|--|---|
| 7.   | DVM.                         | (DC INPUT POWER)<br><br>TP7 to TP1 GND<br><br>TP6 to TP1 GND<br><br>TP4 to TP1 GND<br><br>TP2 to TP1 GND | Use a multimeter to fine tune the input voltages to the tolerances listed:<br><br><br><br><br><br><br><br><br><br>KEYBOARD DECODER CIRCUITRY | +5.0 +/- 0.25 VDC<br><br>+9.0 +/- 0.5 VDC<br><br>+17.0 +/- 1.0 VDC<br><br>+28.0 +/- 2.0 VDC   |
| 8.   |                              |  | Momentarily press S9 MASTER RESET and then S10 DISPLAY RESET switch.   | LCD display on digital interface assembly is blank except for decimal points on HF, UHF-AM, and VHF-AM displays.<br><br>KEYBOARD COUNT and RADIO TRANSMIT STATUS COUNT displays read 00. KEYBOARD CODE display is blank and all RADIO TRANSMIT STATUS indicators are off. PRESENT OCTAL STATE reads 37. |

Table 5-13. RSC CCAs Component Performance Tests - Continued

| Step         | Connection of test equipment | Point of test | Control settings and operation of equipment  | Performance standard   |  |  |              |          |  |                             |             |             |              |              |      |    |    |    |      |  |  |  |   |    |    |    |   |    |    |    |   |    |    |    |      |    |    |    |      |  |  |  |     |    |    |    |   |    |    |    |   |    |    |    |   |    |    |    |    |    |    |    |     |    |    |    |   |    |    |    |   |    |    |    |   |    |    |    |         |    |    |    |     |    |    |    |
|--------------|------------------------------|---------------|--|--|--|--|--------------|----------|--|-----------------------------|-------------|-------------|--------------|--------------|------|----|----|----|------|--|--|--|---|----|----|----|---|----|----|----|---|----|----|----|------|----|----|----|------|--|--|--|-----|----|----|----|---|----|----|----|---|----|----|----|---|----|----|----|----|----|----|----|-----|----|----|----|---|----|----|----|---|----|----|----|---|----|----|----|---------|----|----|----|-----|----|----|----|
| 9.           |                              |               | Press S2 LAMP TEST switch and release.   | PRESENT OCTAL STATE, KEYBOARD CODE, KEYBOARD COUNT and RADIO TRANSMIT STATUS COUNT displays show 88 (when switch is pressed).  |  |  |              |          |  |                             |             |             |              |              |      |    |    |    |      |  |  |  |   |    |    |    |   |    |    |    |   |    |    |    |      |    |    |    |      |  |  |  |     |    |    |    |   |    |    |    |   |    |    |    |   |    |    |    |    |    |    |    |     |    |    |    |   |    |    |    |   |    |    |    |   |    |    |    |         |    |    |    |     |    |    |    |
| 10.          |                              |               | Press the numeral 1 key once on keyboard of RSC panel assembly.                                  | KEYBOARD CODE display shows 01. KEYBOARD COUNT display shows 04. RADIO TRANSMIT STATUS COUNT display shows 08.   |  |  |              |          |  |                             |             |             |              |              |      |    |    |    |      |  |  |  |   |    |    |    |   |    |    |    |   |    |    |    |      |    |    |    |      |  |  |  |     |    |    |    |   |    |    |    |   |    |    |    |   |    |    |    |    |    |    |    |     |    |    |    |   |    |    |    |   |    |    |    |   |    |    |    |         |    |    |    |     |    |    |    |
| 11.          |                              |               | Press each of the following RSC panel assembly keyboard keys once and check the displays listed. | <table border="1"> <thead> <tr> <th data-bbox="784 1020 979 1047">RSC KEYBOARD</th> <th colspan="2" data-bbox="1166 1020 1300 1047">KEYBOARD</th> <th data-bbox="1398 989 1528 1104">RADIO TRANSMIT STATUS COUNT</th> </tr> <tr> <th data-bbox="833 1083 898 1110"><u>KEYS</u></th> <th data-bbox="1138 1083 1203 1110"><u>CODE</u></th> <th data-bbox="1247 1083 1328 1110"><u>COUNT</u></th> <th data-bbox="1430 1083 1511 1110"><u>COUNT</u></th> </tr> </thead> <tbody> <tr> <td data-bbox="784 1146 849 1173">OPER</td> <td data-bbox="1138 1146 1170 1173">14</td> <td data-bbox="1247 1146 1279 1173">08</td> <td data-bbox="1430 1146 1463 1173">16</td> </tr> <tr> <td data-bbox="784 1178 849 1205">&lt;---</td> <td></td> <td></td> <td></td> </tr> <tr> <td data-bbox="784 1209 800 1236">1</td> <td data-bbox="1138 1209 1170 1236">01</td> <td data-bbox="1247 1209 1279 1236">12</td> <td data-bbox="1430 1209 1463 1236">24</td> </tr> <tr> <td data-bbox="784 1241 800 1268">2</td> <td data-bbox="1138 1241 1170 1268">02</td> <td data-bbox="1247 1241 1279 1268">16</td> <td data-bbox="1430 1241 1463 1268">32</td> </tr> <tr> <td data-bbox="784 1272 800 1299">3</td> <td data-bbox="1138 1272 1170 1299">03</td> <td data-bbox="1247 1272 1279 1299">20</td> <td data-bbox="1430 1272 1463 1299">40</td> </tr> <tr> <td data-bbox="784 1304 849 1331">OPER</td> <td data-bbox="1138 1304 1170 1331">15</td> <td data-bbox="1247 1304 1279 1331">24</td> <td data-bbox="1430 1304 1463 1331">48</td> </tr> <tr> <td data-bbox="784 1335 849 1362">---&gt;</td> <td></td> <td></td> <td></td> </tr> <tr> <td data-bbox="784 1367 833 1394">USB</td> <td data-bbox="1138 1367 1170 1394">16</td> <td data-bbox="1247 1367 1279 1394">28</td> <td data-bbox="1430 1367 1463 1394">56</td> </tr> <tr> <td data-bbox="784 1398 800 1425">4</td> <td data-bbox="1138 1398 1170 1425">04</td> <td data-bbox="1247 1398 1279 1425">32</td> <td data-bbox="1430 1398 1463 1425">64</td> </tr> <tr> <td data-bbox="784 1430 800 1457">5</td> <td data-bbox="1138 1430 1170 1457">05</td> <td data-bbox="1247 1430 1279 1457">36</td> <td data-bbox="1430 1430 1463 1457">72</td> </tr> <tr> <td data-bbox="784 1461 800 1488">6</td> <td data-bbox="1138 1461 1170 1488">06</td> <td data-bbox="1247 1461 1279 1488">40</td> <td data-bbox="1430 1461 1463 1488">80</td> </tr> <tr> <td data-bbox="784 1493 816 1520">GD</td> <td data-bbox="1138 1493 1170 1520">21</td> <td data-bbox="1247 1493 1279 1520">44</td> <td data-bbox="1430 1493 1463 1520">88</td> </tr> <tr> <td data-bbox="784 1524 833 1551">LSB</td> <td data-bbox="1138 1524 1170 1551">17</td> <td data-bbox="1247 1524 1279 1551">48</td> <td data-bbox="1430 1524 1463 1551">96</td> </tr> <tr> <td data-bbox="784 1556 800 1583">7</td> <td data-bbox="1138 1556 1170 1583">07</td> <td data-bbox="1247 1556 1279 1583">52</td> <td data-bbox="1430 1556 1463 1583">04</td> </tr> <tr> <td data-bbox="784 1587 800 1614">8</td> <td data-bbox="1138 1587 1170 1614">10</td> <td data-bbox="1247 1587 1279 1614">56</td> <td data-bbox="1430 1587 1463 1614">12</td> </tr> <tr> <td data-bbox="784 1619 800 1646">9</td> <td data-bbox="1138 1619 1170 1646">11</td> <td data-bbox="1247 1619 1279 1646">60</td> <td data-bbox="1430 1619 1463 1646">20</td> </tr> <tr> <td data-bbox="784 1650 898 1677">DF TONE</td> <td data-bbox="1138 1650 1170 1677">22</td> <td data-bbox="1247 1650 1279 1677">64</td> <td data-bbox="1430 1650 1463 1677">28</td> </tr> <tr> <td data-bbox="784 1682 833 1709">SQL</td> <td data-bbox="1138 1682 1170 1709">20</td> <td data-bbox="1247 1682 1279 1709">68</td> <td data-bbox="1430 1682 1463 1709">36</td> </tr> </tbody> </table> |  |  | RSC KEYBOARD | KEYBOARD |  | RADIO TRANSMIT STATUS COUNT | <u>KEYS</u> | <u>CODE</u> | <u>COUNT</u> | <u>COUNT</u> | OPER | 14 | 08 | 16 | <--- |  |  |  | 1 | 01 | 12 | 24 | 2 | 02 | 16 | 32 | 3 | 03 | 20 | 40 | OPER | 15 | 24 | 48 | ---> |  |  |  | USB | 16 | 28 | 56 | 4 | 04 | 32 | 64 | 5 | 05 | 36 | 72 | 6 | 06 | 40 | 80 | GD | 21 | 44 | 88 | LSB | 17 | 48 | 96 | 7 | 07 | 52 | 04 | 8 | 10 | 56 | 12 | 9 | 11 | 60 | 20 | DF TONE | 22 | 64 | 28 | SQL | 20 | 68 | 36 |
| RSC KEYBOARD | KEYBOARD                     |               | RADIO TRANSMIT STATUS COUNT  |  |  |  |              |          |  |                             |             |             |              |              |      |    |    |    |      |  |  |  |   |    |    |    |   |    |    |    |   |    |    |    |      |    |    |    |      |  |  |  |     |    |    |    |   |    |    |    |   |    |    |    |   |    |    |    |    |    |    |    |     |    |    |    |   |    |    |    |   |    |    |    |   |    |    |    |         |    |    |    |     |    |    |    |
| <u>KEYS</u>  | <u>CODE</u>                  | <u>COUNT</u>  | <u>COUNT</u>   |  |  |  |              |          |  |                             |             |             |              |              |      |    |    |    |      |  |  |  |   |    |    |    |   |    |    |    |   |    |    |    |      |    |    |    |      |  |  |  |     |    |    |    |   |    |    |    |   |    |    |    |   |    |    |    |    |    |    |    |     |    |    |    |   |    |    |    |   |    |    |    |   |    |    |    |         |    |    |    |     |    |    |    |
| OPER         | 14                           | 08            | 16   |  |  |  |              |          |  |                             |             |             |              |              |      |    |    |    |      |  |  |  |   |    |    |    |   |    |    |    |   |    |    |    |      |    |    |    |      |  |  |  |     |    |    |    |   |    |    |    |   |    |    |    |   |    |    |    |    |    |    |    |     |    |    |    |   |    |    |    |   |    |    |    |   |    |    |    |         |    |    |    |     |    |    |    |
| <---         |                              |               |  |  |  |  |              |          |  |                             |             |             |              |              |      |    |    |    |      |  |  |  |   |    |    |    |   |    |    |    |   |    |    |    |      |    |    |    |      |  |  |  |     |    |    |    |   |    |    |    |   |    |    |    |   |    |    |    |    |    |    |    |     |    |    |    |   |    |    |    |   |    |    |    |   |    |    |    |         |    |    |    |     |    |    |    |
| 1            | 01                           | 12            | 24   |  |  |  |              |          |  |                             |             |             |              |              |      |    |    |    |      |  |  |  |   |    |    |    |   |    |    |    |   |    |    |    |      |    |    |    |      |  |  |  |     |    |    |    |   |    |    |    |   |    |    |    |   |    |    |    |    |    |    |    |     |    |    |    |   |    |    |    |   |    |    |    |   |    |    |    |         |    |    |    |     |    |    |    |
| 2            | 02                           | 16            | 32   |  |  |  |              |          |  |                             |             |             |              |              |      |    |    |    |      |  |  |  |   |    |    |    |   |    |    |    |   |    |    |    |      |    |    |    |      |  |  |  |     |    |    |    |   |    |    |    |   |    |    |    |   |    |    |    |    |    |    |    |     |    |    |    |   |    |    |    |   |    |    |    |   |    |    |    |         |    |    |    |     |    |    |    |
| 3            | 03                           | 20            | 40   |  |  |  |              |          |  |                             |             |             |              |              |      |    |    |    |      |  |  |  |   |    |    |    |   |    |    |    |   |    |    |    |      |    |    |    |      |  |  |  |     |    |    |    |   |    |    |    |   |    |    |    |   |    |    |    |    |    |    |    |     |    |    |    |   |    |    |    |   |    |    |    |   |    |    |    |         |    |    |    |     |    |    |    |
| OPER         | 15                           | 24            | 48   |  |  |  |              |          |  |                             |             |             |              |              |      |    |    |    |      |  |  |  |   |    |    |    |   |    |    |    |   |    |    |    |      |    |    |    |      |  |  |  |     |    |    |    |   |    |    |    |   |    |    |    |   |    |    |    |    |    |    |    |     |    |    |    |   |    |    |    |   |    |    |    |   |    |    |    |         |    |    |    |     |    |    |    |
| --->         |                              |               |  |  |  |  |              |          |  |                             |             |             |              |              |      |    |    |    |      |  |  |  |   |    |    |    |   |    |    |    |   |    |    |    |      |    |    |    |      |  |  |  |     |    |    |    |   |    |    |    |   |    |    |    |   |    |    |    |    |    |    |    |     |    |    |    |   |    |    |    |   |    |    |    |   |    |    |    |         |    |    |    |     |    |    |    |
| USB          | 16                           | 28            | 56   |  |  |  |              |          |  |                             |             |             |              |              |      |    |    |    |      |  |  |  |   |    |    |    |   |    |    |    |   |    |    |    |      |    |    |    |      |  |  |  |     |    |    |    |   |    |    |    |   |    |    |    |   |    |    |    |    |    |    |    |     |    |    |    |   |    |    |    |   |    |    |    |   |    |    |    |         |    |    |    |     |    |    |    |
| 4            | 04                           | 32            | 64   |  |  |  |              |          |  |                             |             |             |              |              |      |    |    |    |      |  |  |  |   |    |    |    |   |    |    |    |   |    |    |    |      |    |    |    |      |  |  |  |     |    |    |    |   |    |    |    |   |    |    |    |   |    |    |    |    |    |    |    |     |    |    |    |   |    |    |    |   |    |    |    |   |    |    |    |         |    |    |    |     |    |    |    |
| 5            | 05                           | 36            | 72   |  |  |  |              |          |  |                             |             |             |              |              |      |    |    |    |      |  |  |  |   |    |    |    |   |    |    |    |   |    |    |    |      |    |    |    |      |  |  |  |     |    |    |    |   |    |    |    |   |    |    |    |   |    |    |    |    |    |    |    |     |    |    |    |   |    |    |    |   |    |    |    |   |    |    |    |         |    |    |    |     |    |    |    |
| 6            | 06                           | 40            | 80   |  |  |  |              |          |  |                             |             |             |              |              |      |    |    |    |      |  |  |  |   |    |    |    |   |    |    |    |   |    |    |    |      |    |    |    |      |  |  |  |     |    |    |    |   |    |    |    |   |    |    |    |   |    |    |    |    |    |    |    |     |    |    |    |   |    |    |    |   |    |    |    |   |    |    |    |         |    |    |    |     |    |    |    |
| GD           | 21                           | 44            | 88   |  |  |  |              |          |  |                             |             |             |              |              |      |    |    |    |      |  |  |  |   |    |    |    |   |    |    |    |   |    |    |    |      |    |    |    |      |  |  |  |     |    |    |    |   |    |    |    |   |    |    |    |   |    |    |    |    |    |    |    |     |    |    |    |   |    |    |    |   |    |    |    |   |    |    |    |         |    |    |    |     |    |    |    |
| LSB          | 17                           | 48            | 96   |  |  |  |              |          |  |                             |             |             |              |              |      |    |    |    |      |  |  |  |   |    |    |    |   |    |    |    |   |    |    |    |      |    |    |    |      |  |  |  |     |    |    |    |   |    |    |    |   |    |    |    |   |    |    |    |    |    |    |    |     |    |    |    |   |    |    |    |   |    |    |    |   |    |    |    |         |    |    |    |     |    |    |    |
| 7            | 07                           | 52            | 04   |  |  |  |              |          |  |                             |             |             |              |              |      |    |    |    |      |  |  |  |   |    |    |    |   |    |    |    |   |    |    |    |      |    |    |    |      |  |  |  |     |    |    |    |   |    |    |    |   |    |    |    |   |    |    |    |    |    |    |    |     |    |    |    |   |    |    |    |   |    |    |    |   |    |    |    |         |    |    |    |     |    |    |    |
| 8            | 10                           | 56            | 12   |  |  |  |              |          |  |                             |             |             |              |              |      |    |    |    |      |  |  |  |   |    |    |    |   |    |    |    |   |    |    |    |      |    |    |    |      |  |  |  |     |    |    |    |   |    |    |    |   |    |    |    |   |    |    |    |    |    |    |    |     |    |    |    |   |    |    |    |   |    |    |    |   |    |    |    |         |    |    |    |     |    |    |    |
| 9            | 11                           | 60            | 20   |  |  |  |              |          |  |                             |             |             |              |              |      |    |    |    |      |  |  |  |   |    |    |    |   |    |    |    |   |    |    |    |      |    |    |    |      |  |  |  |     |    |    |    |   |    |    |    |   |    |    |    |   |    |    |    |    |    |    |    |     |    |    |    |   |    |    |    |   |    |    |    |   |    |    |    |         |    |    |    |     |    |    |    |
| DF TONE      | 22                           | 64            | 28   |  |  |  |              |          |  |                             |             |             |              |              |      |    |    |    |      |  |  |  |   |    |    |    |   |    |    |    |   |    |    |    |      |    |    |    |      |  |  |  |     |    |    |    |   |    |    |    |   |    |    |    |   |    |    |    |    |    |    |    |     |    |    |    |   |    |    |    |   |    |    |    |   |    |    |    |         |    |    |    |     |    |    |    |
| SQL          | 20                           | 68            | 36   |  |  |  |              |          |  |                             |             |             |              |              |      |    |    |    |      |  |  |  |   |    |    |    |   |    |    |    |   |    |    |    |      |    |    |    |      |  |  |  |     |    |    |    |   |    |    |    |   |    |    |    |   |    |    |    |    |    |    |    |     |    |    |    |   |    |    |    |   |    |    |    |   |    |    |    |         |    |    |    |     |    |    |    |

Table 5-13. RSC CCAs Performance Tests - Continued

| Step          | Connection of test equipment | Point of test | Control settings and operation of equipment  | Performance standard   |  |  |  |         |   |              |   |              |   |        |                    |  |  |  |
|---------------|------------------------------|---------------|--|--|--|--|--|---------|---|--------------|---|--------------|---|--------|--------------------|--|--|--|
| 11.<br>cont.  |                              |               | CLR<br>O/PST<br>ENT<br>SPKR<br>IC<br>VHF-FM<br>VHF-AM<br>UHF-AM<br>HF  | 12<br>00<br>13<br>31<br>24<br>25<br>26<br>27<br>30   | 72<br>76<br>80<br>84<br>88<br>92<br>96<br>00<br>04 | 44<br>52<br>60<br>68<br>76<br>84<br>92<br>00<br>08 |  |         |   |              |   |              |   |        |                    |  |  |  |
| 12.           |                              |               | BACKLIGHTING CIRCUITRY   |  |  |  |  |         |   |              |   |              |   |        |                    |  |  |  |
|               |                              |               | Turn the RSC panel assembly LIGHT control max CW and set the following switches:   |  |  |  |  |         |   |              |   |              |   |        |                    |  |  |  |
|               |                              |               | <table border="0"> <tr> <td><u>SWITCH</u></td> <td><u>POSITION</u></td> </tr> <tr> <td colspan="2">(SELECT CODE)</td> </tr> <tr> <td>S5 FCTN</td> <td>8</td> </tr> <tr> <td>S6 CONDITION</td> <td>0</td> </tr> <tr> <td>S7 CONDITION</td> <td>1</td> </tr> <tr> <td>S8 SET</td> <td>Press momentarily.</td> </tr> </table> | <u>SWITCH</u>  | <u>POSITION</u>                                    | (SELECT CODE)                                      |  | S5 FCTN | 8 | S6 CONDITION | 0 | S7 CONDITION | 1 | S8 SET | Press momentarily. |  |  |  |
| <u>SWITCH</u> | <u>POSITION</u>              |               |  |  |  |  |  |         |   |              |   |              |   |        |                    |  |  |  |
| (SELECT CODE) |                              |               |  |  |  |  |  |         |   |              |   |              |   |        |                    |  |  |  |
| S5 FCTN       | 8                            |               |  |  |  |  |  |         |   |              |   |              |   |        |                    |  |  |  |
| S6 CONDITION  | 0                            |               |  |  |  |  |  |         |   |              |   |              |   |        |                    |  |  |  |
| S7 CONDITION  | 1                            |               |  |  |  |  |  |         |   |              |   |              |   |        |                    |  |  |  |
| S8 SET        | Press momentarily.           |               |  |  |  |  |  |         |   |              |   |              |   |        |                    |  |  |  |
|               |                              |               |  | RSC panel assembly and digital interface assembly backlighting lights.                           |  |  |  |         |   |              |   |              |   |        |                    |  |  |  |
| 13.           |                              |               | Vary RSC panel assembly LIGHT control from max CW to max CCW.  |  |  |  |  |         |   |              |   |              |   |        |                    |  |  |  |
|               |                              |               |  | RSC panel assembly and digital interface assembly backlighting varies from max intensity to off. |  |  |  |         |   |              |   |              |   |        |                    |  |  |  |



Table 5-13. RSC CCAs Performance Tests - Continued

| Step | Connection of test equipment | Point of test | Control settings and operation of equipment   | Performance standard   |
|------|------------------------------|---------------|---|--|
| 14.  |                              |               | <p>EPROM STATE CIRCUITS</p> <p style="text-align: center;"><b>NOTE</b></p> <p>Step 14 will take approximately one minute to perform. The first change will take approximately 30 seconds after switches are held.</p> <p>Press and hold S16 CLOCK switch in the SLOW position while pressing the numeral 2 key on the RSC panel assembly keyboard. Hold both switch and key until PRESENT OCTAL STATE display cycles from 37 to 37 again, then release. CR19 blinks on and off.</p> | PRESENT OCTAL STATE display cycles and shows 37, 36, 35, 34, 33, 32, 31, 30, 27, 26, 25, 24, 23, 22, 21, 20, 17, 16, 15, 35, 34, 33, 32, 31, 30, 27, 26, and 37.   |
| 15.  |                              |               | Refer to table 5-15 and set the RSC Test Set SELECT CODE switches S5, S6, and S7 as listed.   | The displays must display as indicated in table 5-15.  |
| 16.  |                              |               | <p>PTT COMMAND AND CONTROL</p> <p>Press and Hold S17 PUSH TO TALK 1 switch.</p>   | PRESENT OCTAL STATE display shows 01, and RADIO TRANSMIT STATUS PTT CR17 is lit (CR17 off when PTT is released). CR19 COMMAND AND CONTROL DATA PRESENT LIGHTS for approximately one second when S17 is pressed, and again when it is released. |
| 17.  |                              |               | Press and hold S18 PUSH TO TALK 2 switch.   | PRESENT OCTAL STATE display shows 02, and RADIO TRANSMIT STATUS PTT CR18 is lit (CR18 off when PTT is released). CR19 COMMAND AND CONTROL DATA PRESENT lights for approximately one second when S18 is pressed and again when it is released.  |
|      |                              |               | <p>RADIO TRANSMIT STATUS TEST</p> <p style="text-align: center;"><b>NOTE</b></p> <p>The left and right hand RSC panel RADIO TRANSMIT rotary switches will be referred to as OP1 and OP2 respectively.</p>   |  |

Table 5-13. RSC CCAs Performance Tests - Continued

| Step  | Connection of test equipment | Point of test                 | Control settings and operation of equipment  | Performance standard   |                 |             |       |       |              |         |     |         |     |          |       |           |              |  |
|---|------------------------------|-------------------------------|--|--|-----------------|-------------|-------|-------|--------------|---------|-----|---------|-----|----------|-------|-----------|--------------|--|
| 18.   |                              |                               | Set the following switches:<br><br><table border="0"> <tr> <td style="text-align: left;"><u>SWITCH</u></td> <td style="text-align: left;"><u>POSITION</u></td> </tr> <tr> <td>S10 DISPLAY</td> <td>Press</td> </tr> <tr> <td>RESET</td> <td>momentarily.</td> </tr> <tr> <td>RSC OP1</td> <td>OFF</td> </tr> <tr> <td>RSC OP2</td> <td>OFF</td> </tr> <tr> <td>S17 PUSH</td> <td>Press</td> </tr> <tr> <td>TO TALK 1</td> <td>momentarily.</td> </tr> </table> | <u>SWITCH</u>  | <u>POSITION</u> | S10 DISPLAY | Press | RESET | momentarily. | RSC OP1 | OFF | RSC OP2 | OFF | S17 PUSH | Press | TO TALK 1 | momentarily. | CR5 and CR6 RADIO TRANSMIT STATUS LEDs light when S17 is pressed.<br><br><p style="text-align: center;"><b>NOTE</b></p> CR19 COMMAND AND CONTROL DATA PRESENT lights momentarily whenever data is present in the system. |
| <u>SWITCH</u>   | <u>POSITION</u>              |                               |  |  |                 |             |       |       |              |         |     |         |     |          |       |           |              |  |
| S10 DISPLAY   | Press                        |                               |  |  |                 |             |       |       |              |         |     |         |     |          |       |           |              |  |
| RESET   | momentarily.                 |                               |  |  |                 |             |       |       |              |         |     |         |     |          |       |           |              |  |
| RSC OP1   | OFF                          |                               |  |  |                 |             |       |       |              |         |     |         |     |          |       |           |              |  |
| RSC OP2   | OFF                          |                               |  |  |                 |             |       |       |              |         |     |         |     |          |       |           |              |  |
| S17 PUSH  | Press                        |                               |  |  |                 |             |       |       |              |         |     |         |     |          |       |           |              |  |
| TO TALK 1   | momentarily.                 |                               |  |  |                 |             |       |       |              |         |     |         |     |          |       |           |              |  |
| 19.   |                              |                               | Rotate RSC OP1 through the remaining positions and press and release S17 PUSH TO TALK 1 switch for each position.  | The corresponding RADIO TRANSMIT STATUS LEDs on test set light with RSC position. (OPERATOR 1 CR7, 9, 11, 13, 15). CR6 remains on. |                 |             |       |       |              |         |     |         |     |          |       |           |              |  |
| 20.   |                              |                               | Rotate RSC OP1 to the HF position.   |  |                 |             |       |       |              |         |     |         |     |          |       |           |              |  |
| 21.   |                              |                               | Repeat step 18, but with OP2 on RSC, and S18 PUSH TO TALK 2 switch.  | Same as step 18 but using OPERATOR 2, and watching CR8, 10, 12, 14, 16. CR15 remains on, CR6 off. CR18 lights when S18 is pressed. |                 |             |       |       |              |         |     |         |     |          |       |           |              |  |
| 22.   |                              |                               | Rotate RSC OP1 to OFF, OP2 to HF, and press and release S17 PUSH TO TALK 1 switch.   | CR5 and CR16 light, and CR17 lights when S17 is pressed.   |                 |             |       |       |              |         |     |         |     |          |       |           |              |  |
| 23.   |                              |                               | Adjust audio generator for $600 \pm 20$ Hz, $6.0 \pm 1.0$ V p-p (period of 1.61 to 1.72 ms) and connect to (TEST SET AUDIO) - J8 TRANSMIT jack.  |  |                 |             |       |       |              |         |     |         |     |          |       |           |              |  |
| 24.   | Oscilloscope probe.          | (TEST SET AUDIO) - J9 RECEIVE |  | Sine wave of $6.0 \pm 1.0$ V p-p upon which is riding the digitized audio.   |                 |             |       |       |              |         |     |         |     |          |       |           |              |  |
| TEST SET AUDIO RETRANSMIT TEST - RSC OPR 1 AUDIO CHANNELS     |                              |                               |  |  |                 |             |       |       |              |         |     |         |     |          |       |           |              |  |
| <p><b>NOTE</b></p>  |                              |                               |  |  |                 |             |       |       |              |         |     |         |     |          |       |           |              |  |
| The audio generator remains connected for the following test. |                              |                               |  |  |                 |             |       |       |              |         |     |         |     |          |       |           |              |  |

Table 5-13. RSC CCAs Performance Tests - Continued

| Step                   | Connection of test equipment  | Point of test  | Control settings and operation of equipment  | Performance standard |                 |                        |  |                |          |          |                    |                 |  |                     |        |              |         |              |        |  |                    |   |
|------------------------|---|--|--|----------------------|-----------------|------------------------|--|----------------|----------|----------|--------------------|-----------------|--|---------------------|--------|--------------|---------|--------------|--------|--|--------------------|---|
| 25.                    | Oscilloscope.   | J14  | Rotate RSC OP1 and OP2 MSTR VOLUME, IC, VHF-FM, UHF-AM, VHF-AM AND HF volume controls to max CW position.  |                      |                 |                        |  |                |          |          |                    |                 |  |                     |        |              |         |              |        |  |                    |   |
| 26.                    |   |  | Set the following switches:<br><br><table border="0" style="width: 100%;"> <thead> <tr> <th style="text-align: left;"><u>SWITCH</u></th> <th style="text-align: left;"><u>POSITION</u></th> </tr> </thead> <tbody> <tr> <td>(TEST SET AUDIO) - S24</td> <td></td> </tr> <tr> <td>TRANSIT SELECT</td> <td>IC</td> </tr> <tr> <td>RSC OP1</td> <td>IC</td> </tr> <tr> <td>(SELECT CODE) -</td> <td></td> </tr> <tr> <td>S5 FCTN</td> <td>9</td> </tr> <tr> <td>S6 CONDITION</td> <td>0</td> </tr> <tr> <td>S7 CONDITION</td> <td>1</td> </tr> <tr> <td>S8 SET</td> <td>Press momentarily.</td> </tr> </tbody> </table> | <u>SWITCH</u>        | <u>POSITION</u> | (TEST SET AUDIO) - S24 |  | TRANSIT SELECT | IC       | RSC OP1  | IC                 | (SELECT CODE) - |  | S5 FCTN             | 9      | S6 CONDITION | 0       | S7 CONDITION | 1      | S8 SET   | Press momentarily. | (URSC AUDIO) - J14 RECEIVE jack is greater than or equal to 20.0 V p-p. |
| <u>SWITCH</u>          |   |  | <u>POSITION</u>  |                      |                 |                        |  |                |          |          |                    |                 |  |                     |        |              |         |              |        |  |                    |   |
| (TEST SET AUDIO) - S24 |   |  |  |                      |                 |                        |  |                |          |          |                    |                 |  |                     |        |              |         |              |        |  |                    |   |
| TRANSIT SELECT         |   |  | IC   |                      |                 |                        |  |                |          |          |                    |                 |  |                     |        |              |         |              |        |  |                    |   |
| RSC OP1                | IC  |  |  |                      |                 |                        |  |                |          |          |                    |                 |  |                     |        |              |         |              |        |  |                    |   |
| (SELECT CODE) -        |   |  |  |                      |                 |                        |  |                |          |          |                    |                 |  |                     |        |              |         |              |        |  |                    |   |
| S5 FCTN                | 9   |  |  |                      |                 |                        |  |                |          |          |                    |                 |  |                     |        |              |         |              |        |  |                    |   |
| S6 CONDITION           | 0   |  |  |                      |                 |                        |  |                |          |          |                    |                 |  |                     |        |              |         |              |        |  |                    |   |
| S7 CONDITION           | 1   |  |  |                      |                 |                        |  |                |          |          |                    |                 |  |                     |        |              |         |              |        |  |                    |   |
| S8 SET                 | Press momentarily.  |  |  |                      |                 |                        |  |                |          |          |                    |                 |  |                     |        |              |         |              |        |  |                    |   |
| 27.                    | Adjust RSC IC VOL (or respective) control from max CW to max CCW.   | (URSC AUDIO) - J14 RECEIVE jack gradually decreases to less than 1.0 Vrms. |  |                      |                 |                        |  |                |          |          |                    |                 |  |                     |        |              |         |              |        |  |                    |   |
| 28.                    | Return RSC IC VOL (or respective) control to max CW position and rotate (TEST SET AUDIO) - S24 TRANSMIT SELECT switch through the remaining positions.  | (URSC AUDIO) - J14 RECEIVE jack less than or equal to 2.0 Vrms.            |  |                      |                 |                        |  |                |          |          |                    |                 |  |                     |        |              |         |              |        |  |                    |   |
| 29.                    | Repeat steps 26 through 28 and substitute the following switches and controls for each URSC system operator (A-D):<br><br><table border="0" style="width: 100%;"> <thead> <tr> <th style="text-align: left;"><u>SWITCH</u></th> <th colspan="2" style="text-align: left;"><u>POSITION</u></th> </tr> <tr> <td></td> <th colspan="2" style="text-align: left;"><u>SYSTEM</u></th> </tr> <tr> <td></td> <th style="text-align: left;"><u>A</u></th> <th style="text-align: left;"><u>B</u></th> </tr> </thead> <tbody> <tr> <td>(TEST SET AUDIO) -</td> <td></td> <td></td> </tr> <tr> <td>S24 TRANSMIT SELECT</td> <td>VHF-FM</td> <td>UHF-AM</td> </tr> <tr> <td>RSC OP1</td> <td>VHF-FM</td> <td>UHF-AM</td> </tr> </tbody> </table> | <u>SWITCH</u>  | <u>POSITION</u>  |                      |                 | <u>SYSTEM</u>          |  |                | <u>A</u> | <u>B</u> | (TEST SET AUDIO) - |                 |  | S24 TRANSMIT SELECT | VHF-FM | UHF-AM       | RSC OP1 | VHF-FM       | UHF-AM | Same as steps 26 through 28 for each system (A-D). |                    |   |
| <u>SWITCH</u>          | <u>POSITION</u>   |  |  |                      |                 |                        |  |                |          |          |                    |                 |  |                     |        |              |         |              |        |  |                    |   |
|                        | <u>SYSTEM</u>   |  |  |                      |                 |                        |  |                |          |          |                    |                 |  |                     |        |              |         |              |        |  |                    |   |
|                        | <u>A</u>  | <u>B</u>   |  |                      |                 |                        |  |                |          |          |                    |                 |  |                     |        |              |         |              |        |  |                    |   |
| (TEST SET AUDIO) -     |   |  |  |                      |                 |                        |  |                |          |          |                    |                 |  |                     |        |              |         |              |        |  |                    |   |
| S24 TRANSMIT SELECT    | VHF-FM  | UHF-AM   |  |                      |                 |                        |  |                |          |          |                    |                 |  |                     |        |              |         |              |        |  |                    |   |
| RSC OP1                | VHF-FM  | UHF-AM   |  |                      |                 |                        |  |                |          |          |                    |                 |  |                     |        |              |         |              |        |  |                    |   |

Table 5-13. RSC CCAs Performance Tests - Continued

| Step         | Connection of test equipment | Point of test     | Control settings and operation of equipment   | Performance standard   |
|--------------|------------------------------|-------------------|---|--|
| 29.<br>cont. |                              |                   | <p>(SELECT CODE) -</p> <p>S5 FCTN            9     9</p> <p>S6 CONDITION     0     0</p> <p>S7 CONDITION     2     3</p> <p>S8 SET             Press momentarily</p> <p>                       SYSTEM</p> <p>                       <u>C</u>    <u>D</u></p> <p>(TEST SET AUDIO) -</p> <p>S24 TRANSMIT     VHF- HF</p> <p>SELECT             AM</p> <p>RSC OP1            VHF- HF</p> <p>                       AM</p> <p>(SELECT CODE) -</p> <p>S5 FCTN            9     9</p> <p>S6 CONDITION     0     0</p> <p>S7 CONDITION     4     5</p> <p>S8 SET             Press momentarily for each system</p> |  |
| 30.          |                              |                   | <p>Adjust RSC OP1 MASTER VOL control from max CW to max CCW.</p>  | <p>(URSC AUDIO) - J14 RECEIVE jack gradually decreases from greater than or equal to 20.0 V p-p max to less than 1.0 Vrms minimum.</p> |
| 31.          | Oscilloscope.                | To J15 of TS4133. | <p>RSC OPR 2 AUDIO CHANNELS</p> <p>Set the following switches and controls for each system (A-E).</p>   | <p>(URSC AUDIO) - RECEIVE jack greater than or equal to 20.0 V p-p for each system (A-E).</p>  |



Table 5-13. RSC CCAs Performance Tests - Continued

| Step               | Connection of test equipment | Point of test | Control settings and operation of equipment   | Performance standard |                 |                    |  |                    |    |                 |  |         |   |              |   |              |   |        |                    |  |
|--------------------|------------------------------|---------------|---|----------------------|-----------------|--------------------|--|--------------------|----|-----------------|--|---------|---|--------------|---|--------------|---|--------|--------------------|--|
| 33.                |                              |               | SPEAKER TEST  |                      |                 |                    |  |                    |    |                 |  |         |   |              |   |              |   |        |                    |  |
|                    |                              |               | Adjust the audio generator for $400 \pm 20$ Hz and $6.0 \pm 1.0$ V p-p.   |                      |                 |                    |  |                    |    |                 |  |         |   |              |   |              |   |        |                    |  |
| 34.                |                              |               | Set the following switches:   |                      |                 |                    |  |                    |    |                 |  |         |   |              |   |              |   |        |                    |  |
|                    |                              |               | <table border="0" style="width: 100%;"> <tr> <td style="text-align: center;"><u>SWITCH</u></td> <td style="text-align: center;"><u>POSITION</u></td> </tr> <tr> <td colspan="2">(TEST SET AUDIO) -</td> </tr> <tr> <td>S24 TRANSIT SELECT</td> <td style="text-align: center;">IC</td> </tr> <tr> <td colspan="2">(SELECT CODE) -</td> </tr> <tr> <td>S5 FCTN</td> <td style="text-align: center;">9</td> </tr> <tr> <td>S6 CONDITION</td> <td style="text-align: center;">0</td> </tr> <tr> <td>S7 CONDITION</td> <td style="text-align: center;">B</td> </tr> <tr> <td>S8 SET</td> <td style="text-align: center;">Press momentarily.</td> </tr> </table> | <u>SWITCH</u>        | <u>POSITION</u> | (TEST SET AUDIO) - |  | S24 TRANSIT SELECT | IC | (SELECT CODE) - |  | S5 FCTN | 9 | S6 CONDITION | 0 | S7 CONDITION | B | S8 SET | Press momentarily. |  |
| <u>SWITCH</u>      | <u>POSITION</u>              |               |   |                      |                 |                    |  |                    |    |                 |  |         |   |              |   |              |   |        |                    |  |
| (TEST SET AUDIO) - |                              |               |   |                      |                 |                    |  |                    |    |                 |  |         |   |              |   |              |   |        |                    |  |
| S24 TRANSIT SELECT | IC                           |               |   |                      |                 |                    |  |                    |    |                 |  |         |   |              |   |              |   |        |                    |  |
| (SELECT CODE) -    |                              |               |   |                      |                 |                    |  |                    |    |                 |  |         |   |              |   |              |   |        |                    |  |
| S5 FCTN            | 9                            |               |   |                      |                 |                    |  |                    |    |                 |  |         |   |              |   |              |   |        |                    |  |
| S6 CONDITION       | 0                            |               |   |                      |                 |                    |  |                    |    |                 |  |         |   |              |   |              |   |        |                    |  |
| S7 CONDITION       | B                            |               |   |                      |                 |                    |  |                    |    |                 |  |         |   |              |   |              |   |        |                    |  |
| S8 SET             | Press momentarily.           |               |   |                      |                 |                    |  |                    |    |                 |  |         |   |              |   |              |   |        |                    |  |

Pages 5-103 and 5-104 deleted

Table 5-13. RSC CCAs Performance Tests - Continued

| Step         | Connection of test equipment                                       | Point of test                                    | Control settings and operation of equipment   | Performance standard                               |
|--------------|--|--|---|--|
| 34.<br>cont. |  |  | (SPEAKER)- S14<br><br>OUTPUT LOAD/<br>SPEAKER                      OUTPUT LOAD<br><br>RSC SPKR<br>VOLUME                      max CW          |  |
| 35.          | Connect the audio generator to (TEST SET AUDIO)- J8 TRANSMIT jack. |  |   |  |
| 36.          | DVM.   | Measure between (SPEAKER)- OUTPUT J2-A and J3-B. |   | Greater than or equal to 4.0 Vrms.                 |
| 37.          |  | Measure between (SPEAKER)- OUTPUT J2-A and J3-B. | Set RSC Panel Assembly SPKR MUTE/ON switch to the ON position and press and release S17 PUSH TO TALK 1 switch.                                | Greater than or equal to 4.0 Vrms.                 |
| 38.          |  |  | Set RSC Panel Assembly SPKR MUTE/ON switch to the MUTE position and press and hold S17 PUSH TO TALK 1 switch (release S17 after measurement). | Less than 0.4 Vrms.                                |
| 39.          |  |  | Gradually adjust RSC Panel Assembly SPKR VOLUME control from max CW to max CCW.   | Voltage gradually decreases to less than 0.4 Vrms. |
| 40.          |  |  | Adjust RSC Panel Assembly SPKR VOLUME control.  | 1.0 +/- 0.3 Vrms.                                  |

Table 5-13. RSC CCAs Performance Tests - Continued

| Step                                | Connection of test equipment  | Point of test   | Control settings and operation of equipment   | Performance standard   |
|-------------------------------------|---|---|---|--|
| 41.                                 |   |   | Set (SPEAKER)- S14 OUTPUT LOAD/SPEAKER switch to SPEAKER (return to LOAD position after measurement is complete). | 1.0 +/- 0.3 Vrms.  |
| AUDIO RECEIVE TEST - OPR 1 CHANNELS |   |   |   |  |
| 42.                                 | Disconnect the audio generator ground strap for the following test. |   | Adjust audio generator.   | 600 +/- 20 Hz,<br>1.13 +/- 0.11 V p-p<br>(period of 1.61 - 1.72 milliseconds). |
| 43.                                 |   | Connect audio generator to (URSC AUDIO)- TRANSMIT OPERATOR 1 J10 and J11 jacks. |   |  |
| 44.                                 | Oscilloscope probe.   | To (TEST SET AUDIO)- J9 RECEIVE jack.   |   |  |



Table 5-13. RSC CCAs Performance Tests - Continued

| Step               | Connection of test equipment       | Point of test | Control settings and operation of equipment   | Performance standard |                 |        |        |  |                 |  |  |  |          |          |          |   |   |  |              |   |   |   |  |              |   |   |   |  |        |                                    |  |  |  |                    |                                 |  |  |  |  |          |          |  |  |                    |  |  |  |  |                    |  |        |    |  |                 |  |  |  |  |         |   |   |  |  |              |   |   |  |  |              |   |   |  |  |        |                                    |  |  |  |                    |                                 |  |  |  |   |
|--------------------|------------------------------------|---------------|---|----------------------|-----------------|--------|--------|--|-----------------|--|--|--|----------|----------|----------|---|---|--|--------------|---|---|---|--|--------------|---|---|---|--|--------|------------------------------------|--|--|--|--------------------|---------------------------------|--|--|--|--|----------|----------|--|--|--------------------|--|--|--|--|--------------------|--|--------|----|--|-----------------|--|--|--|--|---------|---|---|--|--|--------------|---|---|--|--|--------------|---|---|--|--|--------|------------------------------------|--|--|--|--------------------|---------------------------------|--|--|--|---|
| 45.                |                                    |               | Set the following switches and controls for each system (A-E) starting with IC:<br><table border="0" style="width: 100%;"> <tr> <td style="text-align: center;"><u>SWITCH</u></td> <td style="text-align: center;"><u>POSITION</u></td> <td></td> <td></td> </tr> <tr> <td></td> <td style="text-align: center;">SYSTEM</td> <td></td> <td></td> </tr> <tr> <td></td> <td style="text-align: center;"><u>A</u></td> <td style="text-align: center;"><u>B</u></td> <td style="text-align: center;"><u>C</u></td> </tr> </table> (TEST SET AUDIO) -   | <u>SWITCH</u>        | <u>POSITION</u> |        |        |  | SYSTEM          |  |  |  | <u>A</u> | <u>B</u> | <u>C</u> |   |   |  |              |   |   |   |  |              |   |   |   |  |        |                                    |  |  |  |                    |                                 |  |  |  |  |          |          |  |  |                    |  |  |  |  |                    |  |        |    |  |                 |  |  |  |  |         |   |   |  |  |              |   |   |  |  |              |   |   |  |  |        |                                    |  |  |  |                    |                                 |  |  |  |   |
| <u>SWITCH</u>      | <u>POSITION</u>                    |               |   |                      |                 |        |        |  |                 |  |  |  |          |          |          |   |   |  |              |   |   |   |  |              |   |   |   |  |        |                                    |  |  |  |                    |                                 |  |  |  |  |          |          |  |  |                    |  |  |  |  |                    |  |        |    |  |                 |  |  |  |  |         |   |   |  |  |              |   |   |  |  |              |   |   |  |  |        |                                    |  |  |  |                    |                                 |  |  |  |   |
|                    | SYSTEM                             |               |   |                      |                 |        |        |  |                 |  |  |  |          |          |          |   |   |  |              |   |   |   |  |              |   |   |   |  |        |                                    |  |  |  |                    |                                 |  |  |  |  |          |          |  |  |                    |  |  |  |  |                    |  |        |    |  |                 |  |  |  |  |         |   |   |  |  |              |   |   |  |  |              |   |   |  |  |        |                                    |  |  |  |                    |                                 |  |  |  |   |
|                    | <u>A</u>                           | <u>B</u>      | <u>C</u>  |                      |                 |        |        |  |                 |  |  |  |          |          |          |   |   |  |              |   |   |   |  |              |   |   |   |  |        |                                    |  |  |  |                    |                                 |  |  |  |  |          |          |  |  |                    |  |  |  |  |                    |  |        |    |  |                 |  |  |  |  |         |   |   |  |  |              |   |   |  |  |              |   |   |  |  |        |                                    |  |  |  |                    |                                 |  |  |  |   |
| 46.                |                                    |               | <table border="0" style="width: 100%;"> <tr> <td style="width: 40%;">S25 RECEIVE SELECT</td> <td style="width: 10%;">IC</td> <td style="width: 10%;">VHF-FM</td> <td style="width: 10%;">UHF-AM</td> <td style="width: 20%;"></td> </tr> <tr> <td colspan="5">(SELECT CODE) -</td> </tr> <tr> <td>S5 FCTN</td> <td>A</td> <td>A</td> <td>A</td> <td></td> </tr> <tr> <td>S6 CONDITION</td> <td>0</td> <td>0</td> <td>0</td> <td></td> </tr> <tr> <td>S7 CONDITION</td> <td>1</td> <td>2</td> <td>3</td> <td></td> </tr> <tr> <td>S8 SET</td> <td colspan="4">Press momentarily for each system.</td> </tr> <tr> <td>S17 PUSH TO TALK 1</td> <td colspan="4">Press and hold for each system.</td> </tr> <tr> <td></td> <td style="text-align: center;"><u>D</u></td> <td style="text-align: center;"><u>E</u></td> <td></td> <td></td> </tr> <tr> <td colspan="5">(TEST SET AUDIO) -</td> </tr> <tr> <td>S25 RECEIVE SELECT</td> <td></td> <td>VHF-AM</td> <td>HF</td> <td></td> </tr> <tr> <td colspan="5">(SELECT CODE) -</td> </tr> <tr> <td>S5 FCTN</td> <td>A</td> <td>A</td> <td></td> <td></td> </tr> <tr> <td>S6 CONDITION</td> <td>0</td> <td>0</td> <td></td> <td></td> </tr> <tr> <td>S7 CONDITION</td> <td>4</td> <td>5</td> <td></td> <td></td> </tr> <tr> <td>S8 SET</td> <td colspan="4">Press momentarily for each system.</td> </tr> <tr> <td>S17 PUSH TO TALK 1</td> <td colspan="4">Press and hold for each system.</td> </tr> </table> | S25 RECEIVE SELECT   | IC              | VHF-FM | UHF-AM |  | (SELECT CODE) - |  |  |  |          | S5 FCTN  | A        | A | A |  | S6 CONDITION | 0 | 0 | 0 |  | S7 CONDITION | 1 | 2 | 3 |  | S8 SET | Press momentarily for each system. |  |  |  | S17 PUSH TO TALK 1 | Press and hold for each system. |  |  |  |  | <u>D</u> | <u>E</u> |  |  | (TEST SET AUDIO) - |  |  |  |  | S25 RECEIVE SELECT |  | VHF-AM | HF |  | (SELECT CODE) - |  |  |  |  | S5 FCTN | A | A |  |  | S6 CONDITION | 0 | 0 |  |  | S7 CONDITION | 4 | 5 |  |  | S8 SET | Press momentarily for each system. |  |  |  | S17 PUSH TO TALK 1 | Press and hold for each system. |  |  |  | <p>4.0 ± 0.6 V p-p.</p> <p>4.0 ± 0.6 V p-p.</p> |
| S25 RECEIVE SELECT | IC                                 | VHF-FM        | UHF-AM  |                      |                 |        |        |  |                 |  |  |  |          |          |          |   |   |  |              |   |   |   |  |              |   |   |   |  |        |                                    |  |  |  |                    |                                 |  |  |  |  |          |          |  |  |                    |  |  |  |  |                    |  |        |    |  |                 |  |  |  |  |         |   |   |  |  |              |   |   |  |  |              |   |   |  |  |        |                                    |  |  |  |                    |                                 |  |  |  |   |
| (SELECT CODE) -    |                                    |               |   |                      |                 |        |        |  |                 |  |  |  |          |          |          |   |   |  |              |   |   |   |  |              |   |   |   |  |        |                                    |  |  |  |                    |                                 |  |  |  |  |          |          |  |  |                    |  |  |  |  |                    |  |        |    |  |                 |  |  |  |  |         |   |   |  |  |              |   |   |  |  |              |   |   |  |  |        |                                    |  |  |  |                    |                                 |  |  |  |   |
| S5 FCTN            | A                                  | A             | A   |                      |                 |        |        |  |                 |  |  |  |          |          |          |   |   |  |              |   |   |   |  |              |   |   |   |  |        |                                    |  |  |  |                    |                                 |  |  |  |  |          |          |  |  |                    |  |  |  |  |                    |  |        |    |  |                 |  |  |  |  |         |   |   |  |  |              |   |   |  |  |              |   |   |  |  |        |                                    |  |  |  |                    |                                 |  |  |  |   |
| S6 CONDITION       | 0                                  | 0             | 0   |                      |                 |        |        |  |                 |  |  |  |          |          |          |   |   |  |              |   |   |   |  |              |   |   |   |  |        |                                    |  |  |  |                    |                                 |  |  |  |  |          |          |  |  |                    |  |  |  |  |                    |  |        |    |  |                 |  |  |  |  |         |   |   |  |  |              |   |   |  |  |              |   |   |  |  |        |                                    |  |  |  |                    |                                 |  |  |  |   |
| S7 CONDITION       | 1                                  | 2             | 3   |                      |                 |        |        |  |                 |  |  |  |          |          |          |   |   |  |              |   |   |   |  |              |   |   |   |  |        |                                    |  |  |  |                    |                                 |  |  |  |  |          |          |  |  |                    |  |  |  |  |                    |  |        |    |  |                 |  |  |  |  |         |   |   |  |  |              |   |   |  |  |              |   |   |  |  |        |                                    |  |  |  |                    |                                 |  |  |  |   |
| S8 SET             | Press momentarily for each system. |               |   |                      |                 |        |        |  |                 |  |  |  |          |          |          |   |   |  |              |   |   |   |  |              |   |   |   |  |        |                                    |  |  |  |                    |                                 |  |  |  |  |          |          |  |  |                    |  |  |  |  |                    |  |        |    |  |                 |  |  |  |  |         |   |   |  |  |              |   |   |  |  |              |   |   |  |  |        |                                    |  |  |  |                    |                                 |  |  |  |   |
| S17 PUSH TO TALK 1 | Press and hold for each system.    |               |   |                      |                 |        |        |  |                 |  |  |  |          |          |          |   |   |  |              |   |   |   |  |              |   |   |   |  |        |                                    |  |  |  |                    |                                 |  |  |  |  |          |          |  |  |                    |  |  |  |  |                    |  |        |    |  |                 |  |  |  |  |         |   |   |  |  |              |   |   |  |  |              |   |   |  |  |        |                                    |  |  |  |                    |                                 |  |  |  |   |
|                    | <u>D</u>                           | <u>E</u>      |   |                      |                 |        |        |  |                 |  |  |  |          |          |          |   |   |  |              |   |   |   |  |              |   |   |   |  |        |                                    |  |  |  |                    |                                 |  |  |  |  |          |          |  |  |                    |  |  |  |  |                    |  |        |    |  |                 |  |  |  |  |         |   |   |  |  |              |   |   |  |  |              |   |   |  |  |        |                                    |  |  |  |                    |                                 |  |  |  |   |
| (TEST SET AUDIO) - |                                    |               |   |                      |                 |        |        |  |                 |  |  |  |          |          |          |   |   |  |              |   |   |   |  |              |   |   |   |  |        |                                    |  |  |  |                    |                                 |  |  |  |  |          |          |  |  |                    |  |  |  |  |                    |  |        |    |  |                 |  |  |  |  |         |   |   |  |  |              |   |   |  |  |              |   |   |  |  |        |                                    |  |  |  |                    |                                 |  |  |  |   |
| S25 RECEIVE SELECT |                                    | VHF-AM        | HF  |                      |                 |        |        |  |                 |  |  |  |          |          |          |   |   |  |              |   |   |   |  |              |   |   |   |  |        |                                    |  |  |  |                    |                                 |  |  |  |  |          |          |  |  |                    |  |  |  |  |                    |  |        |    |  |                 |  |  |  |  |         |   |   |  |  |              |   |   |  |  |              |   |   |  |  |        |                                    |  |  |  |                    |                                 |  |  |  |   |
| (SELECT CODE) -    |                                    |               |   |                      |                 |        |        |  |                 |  |  |  |          |          |          |   |   |  |              |   |   |   |  |              |   |   |   |  |        |                                    |  |  |  |                    |                                 |  |  |  |  |          |          |  |  |                    |  |  |  |  |                    |  |        |    |  |                 |  |  |  |  |         |   |   |  |  |              |   |   |  |  |              |   |   |  |  |        |                                    |  |  |  |                    |                                 |  |  |  |   |
| S5 FCTN            | A                                  | A             |   |                      |                 |        |        |  |                 |  |  |  |          |          |          |   |   |  |              |   |   |   |  |              |   |   |   |  |        |                                    |  |  |  |                    |                                 |  |  |  |  |          |          |  |  |                    |  |  |  |  |                    |  |        |    |  |                 |  |  |  |  |         |   |   |  |  |              |   |   |  |  |              |   |   |  |  |        |                                    |  |  |  |                    |                                 |  |  |  |   |
| S6 CONDITION       | 0                                  | 0             |   |                      |                 |        |        |  |                 |  |  |  |          |          |          |   |   |  |              |   |   |   |  |              |   |   |   |  |        |                                    |  |  |  |                    |                                 |  |  |  |  |          |          |  |  |                    |  |  |  |  |                    |  |        |    |  |                 |  |  |  |  |         |   |   |  |  |              |   |   |  |  |              |   |   |  |  |        |                                    |  |  |  |                    |                                 |  |  |  |   |
| S7 CONDITION       | 4                                  | 5             |   |                      |                 |        |        |  |                 |  |  |  |          |          |          |   |   |  |              |   |   |   |  |              |   |   |   |  |        |                                    |  |  |  |                    |                                 |  |  |  |  |          |          |  |  |                    |  |  |  |  |                    |  |        |    |  |                 |  |  |  |  |         |   |   |  |  |              |   |   |  |  |              |   |   |  |  |        |                                    |  |  |  |                    |                                 |  |  |  |   |
| S8 SET             | Press momentarily for each system. |               |   |                      |                 |        |        |  |                 |  |  |  |          |          |          |   |   |  |              |   |   |   |  |              |   |   |   |  |        |                                    |  |  |  |                    |                                 |  |  |  |  |          |          |  |  |                    |  |  |  |  |                    |  |        |    |  |                 |  |  |  |  |         |   |   |  |  |              |   |   |  |  |              |   |   |  |  |        |                                    |  |  |  |                    |                                 |  |  |  |   |
| S17 PUSH TO TALK 1 | Press and hold for each system.    |               |   |                      |                 |        |        |  |                 |  |  |  |          |          |          |   |   |  |              |   |   |   |  |              |   |   |   |  |        |                                    |  |  |  |                    |                                 |  |  |  |  |          |          |  |  |                    |  |  |  |  |                    |  |        |    |  |                 |  |  |  |  |         |   |   |  |  |              |   |   |  |  |              |   |   |  |  |        |                                    |  |  |  |                    |                                 |  |  |  |   |

Table 5-13. RSC CCAs Performance Tests - Continued

| Step | Connection of test equipment | Point of test                                       | Control settings and operation of equipment  | Performance standard             |
|------|------------------------------|---|--|----------------------------------|
| 47.  |                              | J9 URSC AUDIO RECEIVE jack.                         | (TEST SET AUDIO - S25 RECEIVE SELECT Rotate through remaining four positions (with S17 pressed). | Less than or equal to 0.25 Vrms. |
| 48.  | Connect audio generator.     | (URSC AUDIO)-TRANSMIT OPERATOR 2 J12 and J13 jacks. |  |                                  |
| 49.  |                              |   | Set the following switches and controls for each system (A-E) starting with IC:                  |                                  |

Table 5-13. RSC CCAs Component Performance Tests - Continued

| Step        | Connection of test equipment | Point of test | Control settings and operation of equipment   | Performance standard |
|-------------|------------------------------|---------------|---|----------------------|
| 49.<br>cont |                              |               | <p><u>SWITCH</u></p> <p><u>POSITION</u></p> <p>SYSTEM</p> <p><u>A</u>   <u>B</u>   <u>C</u></p> <p>S25 RECEIVE IC VHF- UHF<br/>SELECT FM AM</p> <p>(SELECT CODE) -</p> <p>S5 FCTN A A A</p> <p>S6 CONDITION 0 0 0</p> <p>S7 CONDITION 6 7 8</p> <p>S8 SET Press momenta-<br/>rily for each<br/>system.</p> <p>S18 PUSH TO Press and hold<br/>TALK 2 for each sys-<br/>tem.</p> <p><u>D</u>   <u>E</u></p> <p>(TEST SET AUDIO) -</p> <p>S25 RECEIVE VHF- HF<br/>SELECT AM</p> <p>(SELECT CODE)-</p> <p>S5 FCTN A A</p> <p>S6 CONDITION 0 0</p> <p>S7 CONDITION 9 A</p> <p>S8 SET Press momenta-<br/>rily for each<br/>system</p> | 4.0 +/- 0.6 V p-p.   |

Table 5-13. RSC CCAs Component Performance Tests - Continued

| Step                             | Connection of test equipment                   | Point of test                          | Control settings and operation of equipment   | Performance standard   |
|----------------------------------|--|--|---|--|
| 49.<br>cont                      |  |  | (TEST SET AUDIO)<br><br>S18 PUSH TO TALK 2<br><br>S25 RECEIVE SELECT                              | 4.0 +/- 0.6 V p-p.<br><br>Less than or equal to 0.24 Vrms.           |
|                                  |  | J9 URSC AUDIO RECEIVE jack.            | Press and hold for each system.<br><br>Rotate through remaining four positions (with S18 pressed) |  |
| SPEAKER POWER OFF/ON # LINE TEST |  |  |   |  |
| 50.                              | DVM-Use (DC INPUT POWER) - TP1 GND for ground. | Measure (SPEAKER) - TP9 OFF/ON.        | Place RSC Panel Assembly SPKR VOLUME control to the OFF position.                                 | Greater than 15.0 VDC.   |
| 51.                              | DVM-Use (DC INPUT POWER) - TP1 GND for ground. | Measure VDC at (SPEAKER) - TP9 OFF/ON. | Place RSC Panel Assembly SPKR VOLUME control to max CW.   | Less than 0.5 VDC.   |
| SELECT CODE SCOPE SYNC TEST      |  |  |   |  |
| 52.                              | Reconnect ground strap of audio generator.     |  | Set (SELECT CODE) - S5, S6, and S7 to all zeros and press and release S8 SET switch.              |  |
| 53.                              | Connect oscilloscope probe.                    | To (SELECT CODE SCOPE SYNC) - J6.      |   | Square wave of 9.0 +/- 2.0 V p-p, period of 411 +/- 20 milliseconds. |

Table 5-13. RSC CCAs Performance Tests - Continued

| Step                | Connection of test equipment  | Point of test  | Control settings and operation of equipment   | Performance standard  |                 |                 |  |                 |                    |              |  |                    |                    |                    |  |                     |     |                |          |  |
|---------------------|---|--|---|---|-----------------|-----------------|--|-----------------|--------------------|--------------|--|--------------------|--------------------|--------------------|--|---------------------|-----|----------------|----------|--|
| 54.                 | <p><b>NOTE</b><br/>Ensure a X10 probe is used during the next step.</p> |  | Set (SELECT CODE) - S5, S6, and S7 to a code of 3-0-0 and press and release S8 SET switch.  | Square wave of $9.0 \pm 2.0$ V p-p, period of $102 \pm 5$ milliseconds. |                 |                 |  |                 |                    |              |  |                    |                    |                    |  |                     |     |                |          |  |
| 55.                 | Connect X10 oscilloscope probe. (Time/Div set to 10 microsec).          | <p>To (URSC FIBER</p> <p>OPTIC INTERFACE) - SERIAL DATA J4 IN jack.</p> <p>SERIAL DATA IN J4 jack.</p> | <p>Set the following switches:</p> <table border="0"> <tr> <td><u>SWITCH</u></td> <td><u>POSITION</u></td> </tr> <tr> <td>(SELECT CODE) -</td> <td></td> </tr> <tr> <td>S9 MASTER RESET</td> <td>Press momentarily.</td> </tr> <tr> <td>(RETRANSMIT)</td> <td></td> </tr> <tr> <td>S20 ENABLE/DISABLE</td> <td>Press momentarily.</td> </tr> <tr> <td>(TEST SET AUDIO) -</td> <td></td> </tr> <tr> <td>S24 TRANSMIT SELECT</td> <td>OFF</td> </tr> <tr> <td>S23 XMT SELECT</td> <td>IDLE OFF</td> </tr> </table> <p>(Hold for measurement, then release.)</p> | <u>SWITCH</u>   | <u>POSITION</u> | (SELECT CODE) - |  | S9 MASTER RESET | Press momentarily. | (RETRANSMIT) |  | S20 ENABLE/DISABLE | Press momentarily. | (TEST SET AUDIO) - |  | S24 TRANSMIT SELECT | OFF | S23 XMT SELECT | IDLE OFF | <p>CR21 ENABLED LED lights.</p> <p>One pulse wave of greater than or equal to 3.5 Vdc. amplitude (logic hi), for <math>30 \pm 3</math> usec duration, and a logic lo of less than or equal to 1.0 Vdc for <math>10 \pm 1</math> usec duration.</p> |
| <u>SWITCH</u>       | <u>POSITION</u>   |  |   |   |                 |                 |  |                 |                    |              |  |                    |                    |                    |  |                     |     |                |          |  |
| (SELECT CODE) -     |   |  |   |   |                 |                 |  |                 |                    |              |  |                    |                    |                    |  |                     |     |                |          |  |
| S9 MASTER RESET     | Press momentarily.  |  |   |   |                 |                 |  |                 |                    |              |  |                    |                    |                    |  |                     |     |                |          |  |
| (RETRANSMIT)        |   |  |   |   |                 |                 |  |                 |                    |              |  |                    |                    |                    |  |                     |     |                |          |  |
| S20 ENABLE/DISABLE  | Press momentarily.  |  |   |   |                 |                 |  |                 |                    |              |  |                    |                    |                    |  |                     |     |                |          |  |
| (TEST SET AUDIO) -  |   |  |   |   |                 |                 |  |                 |                    |              |  |                    |                    |                    |  |                     |     |                |          |  |
| S24 TRANSMIT SELECT | OFF   |  |   |   |                 |                 |  |                 |                    |              |  |                    |                    |                    |  |                     |     |                |          |  |
| S23 XMT SELECT      | IDLE OFF  |  |   |   |                 |                 |  |                 |                    |              |  |                    |                    |                    |  |                     |     |                |          |  |

Table 5-13. RSC CCAs Performance Tests - Continued

| Step                              | Connection of test equipment | Point of test | Control settings and operation of equipment  | Performance standard             |                 |                 |                    |                 |                     |                                   |                 |  |         |                |              |                 |              |   |        |                    |                 |  |                     |             |
|-----------------------------------|------------------------------|---------------|--|----------------------------------|-----------------|-----------------|--------------------|-----------------|---------------------|-----------------------------------|-----------------|--|---------|----------------|--------------|-----------------|--------------|---|--------|--------------------|-----------------|--|---------------------|-------------|
| 56.                               |                              |               | <p style="text-align: center;">SPEAKER AMP OUTPUT CHECK</p> <p>Set the following switches:</p> <table border="0" style="width: 100%;"> <tr> <td style="text-align: center;"><u>SWITCH</u></td> <td style="text-align: center;"><u>POSITION</u></td> </tr> <tr> <td colspan="2">(SELECT CODE)</td> </tr> <tr> <td>S9 MASTER RESET</td> <td>Press momentarily.</td> </tr> <tr> <td colspan="2">RSC Panel Assembly BATTERY switch</td> </tr> <tr> <td></td> <td>ON</td> </tr> <tr> <td colspan="2">(POWER SOURCE)</td> </tr> <tr> <td>S13 BATTERY/SDU</td> <td>BATTERY</td> </tr> </table>  | <u>SWITCH</u>                    | <u>POSITION</u> | (SELECT CODE)   |                    | S9 MASTER RESET | Press momentarily.  | RSC Panel Assembly BATTERY switch |                 |  | ON      | (POWER SOURCE) |              | S13 BATTERY/SDU | BATTERY      |   |        |                    |                 |  |                     |             |
| <u>SWITCH</u>                     | <u>POSITION</u>              |               |  |                                  |                 |                 |                    |                 |                     |                                   |                 |  |         |                |              |                 |              |   |        |                    |                 |  |                     |             |
| (SELECT CODE)                     |                              |               |  |                                  |                 |                 |                    |                 |                     |                                   |                 |  |         |                |              |                 |              |   |        |                    |                 |  |                     |             |
| S9 MASTER RESET                   | Press momentarily.           |               |  |                                  |                 |                 |                    |                 |                     |                                   |                 |  |         |                |              |                 |              |   |        |                    |                 |  |                     |             |
| RSC Panel Assembly BATTERY switch |                              |               |  |                                  |                 |                 |                    |                 |                     |                                   |                 |  |         |                |              |                 |              |   |        |                    |                 |  |                     |             |
|                                   | ON                           |               |  |                                  |                 |                 |                    |                 |                     |                                   |                 |  |         |                |              |                 |              |   |        |                    |                 |  |                     |             |
| (POWER SOURCE)                    |                              |               |  |                                  |                 |                 |                    |                 |                     |                                   |                 |  |         |                |              |                 |              |   |        |                    |                 |  |                     |             |
| S13 BATTERY/SDU                   | BATTERY                      |               |  |                                  |                 |                 |                    |                 |                     |                                   |                 |  |         |                |              |                 |              |   |        |                    |                 |  |                     |             |
| 57.                               |                              |               | Adjust the audio generator.  | 400 ± 20 Hz and 6.0 ± 1.0 V p-p. |                 |                 |                    |                 |                     |                                   |                 |  |         |                |              |                 |              |   |        |                    |                 |  |                     |             |
| 58.                               |                              |               | <p>Set the following switches:</p> <table border="0" style="width: 100%;"> <tr> <td style="text-align: center;"><u>SWITCH</u></td> <td style="text-align: center;"><u>POSITION</u></td> </tr> <tr> <td colspan="2">(TEST SET AUDIO) -</td> </tr> <tr> <td>S24 TRANSMIT SELECT</td> <td>IC</td> </tr> <tr> <td colspan="2">(SELECT CODE) -</td> </tr> <tr> <td>S5 FCTN</td> <td>9</td> </tr> <tr> <td>S6 CONDITION</td> <td>0</td> </tr> <tr> <td>S7 CONDITION</td> <td>B</td> </tr> <tr> <td>S8 SET</td> <td>Press momentarily.</td> </tr> <tr> <td colspan="2">(SPEAKER) - S14</td> </tr> <tr> <td>OUTPUT LOAD/SPEAKER</td> <td>OUTPUT LOAD</td> </tr> </table> |                                  | <u>SWITCH</u>   | <u>POSITION</u> | (TEST SET AUDIO) - |                 | S24 TRANSMIT SELECT | IC                                | (SELECT CODE) - |  | S5 FCTN | 9              | S6 CONDITION | 0               | S7 CONDITION | B | S8 SET | Press momentarily. | (SPEAKER) - S14 |  | OUTPUT LOAD/SPEAKER | OUTPUT LOAD |
| <u>SWITCH</u>                     | <u>POSITION</u>              |               |  |                                  |                 |                 |                    |                 |                     |                                   |                 |  |         |                |              |                 |              |   |        |                    |                 |  |                     |             |
| (TEST SET AUDIO) -                |                              |               |  |                                  |                 |                 |                    |                 |                     |                                   |                 |  |         |                |              |                 |              |   |        |                    |                 |  |                     |             |
| S24 TRANSMIT SELECT               | IC                           |               |  |                                  |                 |                 |                    |                 |                     |                                   |                 |  |         |                |              |                 |              |   |        |                    |                 |  |                     |             |
| (SELECT CODE) -                   |                              |               |  |                                  |                 |                 |                    |                 |                     |                                   |                 |  |         |                |              |                 |              |   |        |                    |                 |  |                     |             |
| S5 FCTN                           | 9                            |               |  |                                  |                 |                 |                    |                 |                     |                                   |                 |  |         |                |              |                 |              |   |        |                    |                 |  |                     |             |
| S6 CONDITION                      | 0                            |               |  |                                  |                 |                 |                    |                 |                     |                                   |                 |  |         |                |              |                 |              |   |        |                    |                 |  |                     |             |
| S7 CONDITION                      | B                            |               |  |                                  |                 |                 |                    |                 |                     |                                   |                 |  |         |                |              |                 |              |   |        |                    |                 |  |                     |             |
| S8 SET                            | Press momentarily.           |               |  |                                  |                 |                 |                    |                 |                     |                                   |                 |  |         |                |              |                 |              |   |        |                    |                 |  |                     |             |
| (SPEAKER) - S14                   |                              |               |  |                                  |                 |                 |                    |                 |                     |                                   |                 |  |         |                |              |                 |              |   |        |                    |                 |  |                     |             |
| OUTPUT LOAD/SPEAKER               | OUTPUT LOAD                  |               |  |                                  |                 |                 |                    |                 |                     |                                   |                 |  |         |                |              |                 |              |   |        |                    |                 |  |                     |             |

Table 5-13. RSC CCAs Performance Tests - Continued

| Step         | Connection of test equipment  | Point of test                                     | Control settings and operation of equipment  | Performance standard                              |
|--------------|---|---|--|---|
| 58.<br>cont. |   |   | RSC SPKR<br>VOLUME           max CW<br><br>RSC IC<br>VOL                Ensure<br>max CW                                     |   |
| 59.          | Connect the audio generator to (TEST SET AUDIO) - J8 TRANSMIT jack. |   |  |   |
| 60.          | Use DVM to measure Vrms.  | Measure between (SPEAKER) - OUTPUT and J2-A J3-B. |  | Greater than or equal to 4.0 Vrms.                |
| 61.          |   |   | SHUTDOWN PROCEDURES<br><br>Set RSC Panel Assembly BATTERY switch to the down position.                                       | (PRESENT OCTAL STATE) display goes from 37 to 00. |
| 62.          |   |   | Set S1 switch to the down position, turn off all power supplies, disconnect cable W1 and all other cables from the RSC CCAS. |   |





Table 5-14. RSC CCAs Fault Isolation Tests

| Step                        | Procedure  | Normal indication | Fault location  |    |      |               |  |                 |     |                     |     |                  |  |                 |     |             |  |                             |         |   |  |
|-----------------------------|--|-------------------|-----------------|----|------|---------------|--|-----------------|-----|---------------------|-----|------------------|--|-----------------|-----|-------------|--|-----------------------------|---------|---|--|
|                             | <p style="text-align: center;">NOTE</p> <p>Switches, indicators, and test point references are on the URSC test set TS4133 unless otherwise noted. Set all switches to OFF or down to begin procedure.</p> <p>1. Visually inspect circuit card for physical damage; i.e., broken traces, corrosion.</p> <p>2. Connect test equipment as shown in figure 5-13.</p> <p>3. Jumper the common grounds together on power supplies. Adjust power supplies for desired voltages.</p> <p>4. Set the TS4133 switches:</p> <table style="width: 100%; border-collapse: collapse;"> <thead> <tr> <th style="text-align: left; border-bottom: 1px solid black;"><u>SWITCH</u></th> <th style="text-align: left; border-bottom: 1px solid black;"><u>POSITION</u></th> </tr> </thead> <tbody> <tr> <td>S1</td> <td>down</td> </tr> <tr> <td colspan="2" style="padding-top: 10px;">(DATA MODE) -</td> </tr> <tr> <td style="padding-left: 20px;">S11 URSC ON/OFF</td> <td>OFF</td> </tr> <tr> <td style="padding-left: 20px;">S12 TEST SET ON/OFF</td> <td>OFF</td> </tr> <tr> <td colspan="2" style="padding-top: 10px;">(POWER SOURCE) -</td> </tr> <tr> <td style="padding-left: 20px;">S13 BATTERY/SDU</td> <td>SDU</td> </tr> <tr> <td colspan="2" style="padding-top: 10px;">(SPEAKER) -</td> </tr> <tr> <td style="padding-left: 20px;">S14 OUTPUT LOAD/<br/>SPEAKER</td> <td>SPEAKER</td> </tr> </tbody> </table> | <u>SWITCH</u>     | <u>POSITION</u> | S1 | down | (DATA MODE) - |  | S11 URSC ON/OFF | OFF | S12 TEST SET ON/OFF | OFF | (POWER SOURCE) - |  | S13 BATTERY/SDU | SDU | (SPEAKER) - |  | S14 OUTPUT LOAD/<br>SPEAKER | SPEAKER | <p style="text-align: center;">NOTE</p> <p>Ignore status of all indicators that are not listed.</p> <p>No physically damaged, broken or corroded parts.</p> | <p>Remove and replace all damaged, broken or corroded parts.</p> |
| <u>SWITCH</u>               | <u>POSITION</u>  |                   |                 |    |      |               |  |                 |     |                     |     |                  |  |                 |     |             |  |                             |         |   |  |
| S1                          | down   |                   |                 |    |      |               |  |                 |     |                     |     |                  |  |                 |     |             |  |                             |         |   |  |
| (DATA MODE) -               |  |                   |                 |    |      |               |  |                 |     |                     |     |                  |  |                 |     |             |  |                             |         |   |  |
| S11 URSC ON/OFF             | OFF  |                   |                 |    |      |               |  |                 |     |                     |     |                  |  |                 |     |             |  |                             |         |   |  |
| S12 TEST SET ON/OFF         | OFF  |                   |                 |    |      |               |  |                 |     |                     |     |                  |  |                 |     |             |  |                             |         |   |  |
| (POWER SOURCE) -            |  |                   |                 |    |      |               |  |                 |     |                     |     |                  |  |                 |     |             |  |                             |         |   |  |
| S13 BATTERY/SDU             | SDU  |                   |                 |    |      |               |  |                 |     |                     |     |                  |  |                 |     |             |  |                             |         |   |  |
| (SPEAKER) -                 |  |                   |                 |    |      |               |  |                 |     |                     |     |                  |  |                 |     |             |  |                             |         |   |  |
| S14 OUTPUT LOAD/<br>SPEAKER | SPEAKER  |                   |                 |    |      |               |  |                 |     |                     |     |                  |  |                 |     |             |  |                             |         |   |  |

Table 5-14. RSC CCAs Fault Isolation Tests - Continued

| Step        | Procedure   | Normal indication  | Fault location |
|-------------|---|--|----------------|
| 4.<br>cont. | <p>(RETRANSMIT)</p> <p>S19 AUTO START        OFF</p> <p>(TEST SET AUDIO)-</p> <p>S24 TRANSMIT SELECT OFF</p> <p>S25 RECEIVE SELECT    OFF</p> <p>(SERIAL DATA IN)</p> <p>VOLTAGE ADJUST</p> <p>R1 UPPER max CCW</p> <p>R2 LOWER max CCW</p>                                 |  |                |
| 5.          | <p>On the RSC front panel:</p> <p>R1 OFF LIGHT            max CCW</p> <p>R2 MSTR VOL            max CCW</p>   |  |                |
| 6.          | <p>Set S1 to the ON position.</p>   | <p>CR1 through CR4 light.</p>  |                |
| 7.          | <p>Use a multimeter to fine tune the input voltages to the tolerances at the following test points:</p> <p>DC INPUT POWER</p> <p><u>TEST POINTS</u></p> <p>+ LEAD        - LEAD</p> <p>TP7 to TP1 GND</p> <p>TP6 to TP1 GND</p> <p>TP4 to TP1 GND</p> <p>TP2 to TP1 GND</p> | <p>+5.0 +/- 0.25 VDC</p> <p>+9.0 +/- 0.5 VDC</p> <p>+17.0 +/- 1.0 VDC</p> <p>+28.0 +/- 2.0 VDC</p> |                |

Table 5-14. RSC CCAs Fault Isolation Tests - Continued

| Step                       | Procedure  | Normal indication   | Fault location  |
|----------------------------|--|---|---|
| KEYBOARD DECODER CIRCUITRY |  |   |   |
| 8.                         | Momentarily press S9 MASTER RESET and then S10 DISPLAY RESET switch. | LCD display on digital interface assembly is blank except for decimal points on HF, UHF-AM, VHF-AM. KEYBOARD COUNT and RADIO TRANSMIT STATUS COUNT displays read 00. KEYBOARD CODE display is blank and all RADIO TRANSMIT STATUS indicators are off. PRESENT OCTAL STATE reads 37. | Normal indications present: step 14.<br>Absent: step 9. |
| 9.                         | Connect oscilloscope probe to digital interface TP31.                | Oscilloscope indicates groups of four positions going pulses 8 ms wide, 8.4 V p-p.  | Present: U1, DS1.<br>Absent: U6 or step 45.             |
| 10.                        | Connect oscilloscope probe to digital interface TP32.                | Oscilloscope indicates same as step 9.  | Present: U2, DS1.<br>Absent: U6 or step 45.             |
| 11.                        | Connect oscilloscope probe to digital interface TP33.                | Oscilloscope indicates same as step 9.  | Present: U3, DS3.<br>Absent: U7 or step 45.             |
| 12.                        | Connect oscilloscope probe to digital interface TP34.                | Oscilloscope indicates positive going pulses 10 ms wide, 8.3 V p-p.   | Present: U5, DS4.<br>Absent: U7 or step 45.             |

Table 5-14. RSC CCAs Fault Isolation Tests - Continued

| Step | Procedure  | Normal indication  | Fault location  |
|------|--|--|---|
| 13.  | Connect oscilloscope probe to digital interface TP35.                    | Oscilloscope indicates same as step 12.  | Present: U4, DS4,<br>Absent: U7 or step 45.   |
| 14.  | Press S2 LAMP TEST switch and release.                                   | PRESENT OCTAL STATE, KEYBOARD CODE, KEYBOARD COUNT, and RADIO TRANSMIT STATUS COUNT displays show 88 (when pressed). | Normal indications present: step 16.<br>Absent: step 15.  |
| 15.  | Connect oscilloscope probe to TPs 17 through 21 in turn.                 | Oscilloscope indicates greater than 8 VDC level.   | Present: step 24.<br>Absent: Ensure correct wiring connections between TPs 17-21 on digital interface, and plug J8 on RSC test set. |
| 16.  | Press the numeral 1 key once on the keyboard of the RSC panel assembly.  | KEYBOARD CODE display shows 01.<br>KEYBOARD COUNT display shows 04.<br>RADIO TRANSMIT STATUS COUNR display shows 08. | Normal indications present: step 20.<br>Absent: step 17.  |
| 17.  | Connect oscilloscope to digital interface TP26.                          | Oscilloscope indicates greater than 8 VDC level.   | Present: step 19.<br>Absent: step 18.   |
| 18.  | Connect oscilloscope to digital interface TP22. Push any key repeatedly. | Oscilloscope indicates a positive going square wave when key is pushed.  | Present: U38, U37, R25.<br>Absent: step 24.   |
| 19.  | Connect oscilloscope to digital interface TP25.                          | Oscilloscope indicates greater than 8 VDC level.   | Present: U40.<br>Absent step 24.  |

Table 5-14. RSC CCAs Fault Isolation Tests - Continued

| Step          | Procedure   | Normal indication  | Fault location |       |                             |    |    |    |    |    |    |    |    |    |    |    |    |    |    |    |    |    |    |    |    |    |    |    |    |    |    |    |    |    |    |    |    |    |    |    |    |    |    |    |    |    |    |    |    |    |    |    |    |    |    |    |    |    |    |    |    |    |    |    |    |    |    |    |    |    |    |    |    |    |    |    |    |    |    |    |  |
|---------------|---|--|----------------|-------|-----------------------------|----|----|----|----|----|----|----|----|----|----|----|----|----|----|----|----|----|----|----|----|----|----|----|----|----|----|----|----|----|----|----|----|----|----|----|----|----|----|----|----|----|----|----|----|----|----|----|----|----|----|----|----|----|----|----|----|----|----|----|----|----|----|----|----|----|----|----|----|----|----|----|----|----|----|----|--|
| 20.           | <p>Press the following RSC panel assembly keyboard keys (once) and check the displays listed.</p> <p>RSC Panel Assembly</p> <p>RSC KEYBOARD</p> <p>OPER - - - - -</p> <p>&lt;- - - - -</p> <p>1 - - - - -</p> <p>2 - - - - -</p> <p>3 - - - - -</p> <p>OPER - - - - -</p> <p>---&gt;</p> <p>USB - - - - -</p> <p>4 - - - - -</p> <p>5 - - - - -</p> <p>6 - - - - -</p> <p>GD - - - - -</p> <p>LSB - - - - -</p> <p>7 - - - - -</p> <p>8 - - - - -</p> <p>9 - - - - -</p> <p>DF TONE - - - - -</p> <p>SQL - - - - -</p> <p>CLR - - - - -</p> <p>O/PST - - - - -</p> <p>ENT - - - - -</p> <p>SPKR - - - - -</p> <p>IC - - - - -</p> <p>VHF-FM - - - - -</p> <p>VHF-AM - - - - -</p> <p>UHF-AM - - - - -</p> <p>HF - - - - -</p> | <p>TEST SET DISPLAYS</p> <table border="1"> <thead> <tr> <th data-bbox="915 646 1045 705">KEYBOARD CODE</th> <th data-bbox="1029 674 1110 705">COUNT</th> <th data-bbox="1094 590 1240 705">RADIO TRANSMIT STATUS COUNT</th> </tr> </thead> <tbody> <tr><td>14</td><td>08</td><td>16</td></tr> <tr><td>01</td><td>12</td><td>24</td></tr> <tr><td>02</td><td>16</td><td>32</td></tr> <tr><td>03</td><td>20</td><td>40</td></tr> <tr><td>15</td><td>24</td><td>48</td></tr> <tr><td>16</td><td>28</td><td>56</td></tr> <tr><td>04</td><td>32</td><td>64</td></tr> <tr><td>05</td><td>36</td><td>72</td></tr> <tr><td>06</td><td>40</td><td>80</td></tr> <tr><td>21</td><td>44</td><td>88</td></tr> <tr><td>17</td><td>48</td><td>96</td></tr> <tr><td>07</td><td>52</td><td>04</td></tr> <tr><td>10</td><td>56</td><td>12</td></tr> <tr><td>11</td><td>60</td><td>20</td></tr> <tr><td>22</td><td>64</td><td>28</td></tr> <tr><td>20</td><td>68</td><td>36</td></tr> <tr><td>12</td><td>72</td><td>44</td></tr> <tr><td>00</td><td>76</td><td>52</td></tr> <tr><td>13</td><td>80</td><td>60</td></tr> <tr><td>31</td><td>84</td><td>68</td></tr> <tr><td>24</td><td>88</td><td>76</td></tr> <tr><td>25</td><td>92</td><td>84</td></tr> <tr><td>26</td><td>96</td><td>92</td></tr> <tr><td>27</td><td>00</td><td>00</td></tr> <tr><td>30</td><td>04</td><td>08</td></tr> </tbody> </table> | KEYBOARD CODE  | COUNT | RADIO TRANSMIT STATUS COUNT | 14 | 08 | 16 | 01 | 12 | 24 | 02 | 16 | 32 | 03 | 20 | 40 | 15 | 24 | 48 | 16 | 28 | 56 | 04 | 32 | 64 | 05 | 36 | 72 | 06 | 40 | 80 | 21 | 44 | 88 | 17 | 48 | 96 | 07 | 52 | 04 | 10 | 56 | 12 | 11 | 60 | 20 | 22 | 64 | 28 | 20 | 68 | 36 | 12 | 72 | 44 | 00 | 76 | 52 | 13 | 80 | 60 | 31 | 84 | 68 | 24 | 88 | 76 | 25 | 92 | 84 | 26 | 96 | 92 | 27 | 00 | 00 | 30 | 04 | 08 | <p>Normal indications present: step 21.<br/>Absent: step 16.</p> |
| KEYBOARD CODE | COUNT   | RADIO TRANSMIT STATUS COUNT  |                |       |                             |    |    |    |    |    |    |    |    |    |    |    |    |    |    |    |    |    |    |    |    |    |    |    |    |    |    |    |    |    |    |    |    |    |    |    |    |    |    |    |    |    |    |    |    |    |    |    |    |    |    |    |    |    |    |    |    |    |    |    |    |    |    |    |    |    |    |    |    |    |    |    |    |    |    |    |  |
| 14            | 08  | 16   |                |       |                             |    |    |    |    |    |    |    |    |    |    |    |    |    |    |    |    |    |    |    |    |    |    |    |    |    |    |    |    |    |    |    |    |    |    |    |    |    |    |    |    |    |    |    |    |    |    |    |    |    |    |    |    |    |    |    |    |    |    |    |    |    |    |    |    |    |    |    |    |    |    |    |    |    |    |    |  |
| 01            | 12  | 24   |                |       |                             |    |    |    |    |    |    |    |    |    |    |    |    |    |    |    |    |    |    |    |    |    |    |    |    |    |    |    |    |    |    |    |    |    |    |    |    |    |    |    |    |    |    |    |    |    |    |    |    |    |    |    |    |    |    |    |    |    |    |    |    |    |    |    |    |    |    |    |    |    |    |    |    |    |    |    |  |
| 02            | 16  | 32   |                |       |                             |    |    |    |    |    |    |    |    |    |    |    |    |    |    |    |    |    |    |    |    |    |    |    |    |    |    |    |    |    |    |    |    |    |    |    |    |    |    |    |    |    |    |    |    |    |    |    |    |    |    |    |    |    |    |    |    |    |    |    |    |    |    |    |    |    |    |    |    |    |    |    |    |    |    |    |  |
| 03            | 20  | 40   |                |       |                             |    |    |    |    |    |    |    |    |    |    |    |    |    |    |    |    |    |    |    |    |    |    |    |    |    |    |    |    |    |    |    |    |    |    |    |    |    |    |    |    |    |    |    |    |    |    |    |    |    |    |    |    |    |    |    |    |    |    |    |    |    |    |    |    |    |    |    |    |    |    |    |    |    |    |    |  |
| 15            | 24  | 48   |                |       |                             |    |    |    |    |    |    |    |    |    |    |    |    |    |    |    |    |    |    |    |    |    |    |    |    |    |    |    |    |    |    |    |    |    |    |    |    |    |    |    |    |    |    |    |    |    |    |    |    |    |    |    |    |    |    |    |    |    |    |    |    |    |    |    |    |    |    |    |    |    |    |    |    |    |    |    |  |
| 16            | 28  | 56   |                |       |                             |    |    |    |    |    |    |    |    |    |    |    |    |    |    |    |    |    |    |    |    |    |    |    |    |    |    |    |    |    |    |    |    |    |    |    |    |    |    |    |    |    |    |    |    |    |    |    |    |    |    |    |    |    |    |    |    |    |    |    |    |    |    |    |    |    |    |    |    |    |    |    |    |    |    |    |  |
| 04            | 32  | 64   |                |       |                             |    |    |    |    |    |    |    |    |    |    |    |    |    |    |    |    |    |    |    |    |    |    |    |    |    |    |    |    |    |    |    |    |    |    |    |    |    |    |    |    |    |    |    |    |    |    |    |    |    |    |    |    |    |    |    |    |    |    |    |    |    |    |    |    |    |    |    |    |    |    |    |    |    |    |    |  |
| 05            | 36  | 72   |                |       |                             |    |    |    |    |    |    |    |    |    |    |    |    |    |    |    |    |    |    |    |    |    |    |    |    |    |    |    |    |    |    |    |    |    |    |    |    |    |    |    |    |    |    |    |    |    |    |    |    |    |    |    |    |    |    |    |    |    |    |    |    |    |    |    |    |    |    |    |    |    |    |    |    |    |    |    |  |
| 06            | 40  | 80   |                |       |                             |    |    |    |    |    |    |    |    |    |    |    |    |    |    |    |    |    |    |    |    |    |    |    |    |    |    |    |    |    |    |    |    |    |    |    |    |    |    |    |    |    |    |    |    |    |    |    |    |    |    |    |    |    |    |    |    |    |    |    |    |    |    |    |    |    |    |    |    |    |    |    |    |    |    |    |  |
| 21            | 44  | 88   |                |       |                             |    |    |    |    |    |    |    |    |    |    |    |    |    |    |    |    |    |    |    |    |    |    |    |    |    |    |    |    |    |    |    |    |    |    |    |    |    |    |    |    |    |    |    |    |    |    |    |    |    |    |    |    |    |    |    |    |    |    |    |    |    |    |    |    |    |    |    |    |    |    |    |    |    |    |    |  |
| 17            | 48  | 96   |                |       |                             |    |    |    |    |    |    |    |    |    |    |    |    |    |    |    |    |    |    |    |    |    |    |    |    |    |    |    |    |    |    |    |    |    |    |    |    |    |    |    |    |    |    |    |    |    |    |    |    |    |    |    |    |    |    |    |    |    |    |    |    |    |    |    |    |    |    |    |    |    |    |    |    |    |    |    |  |
| 07            | 52  | 04   |                |       |                             |    |    |    |    |    |    |    |    |    |    |    |    |    |    |    |    |    |    |    |    |    |    |    |    |    |    |    |    |    |    |    |    |    |    |    |    |    |    |    |    |    |    |    |    |    |    |    |    |    |    |    |    |    |    |    |    |    |    |    |    |    |    |    |    |    |    |    |    |    |    |    |    |    |    |    |  |
| 10            | 56  | 12   |                |       |                             |    |    |    |    |    |    |    |    |    |    |    |    |    |    |    |    |    |    |    |    |    |    |    |    |    |    |    |    |    |    |    |    |    |    |    |    |    |    |    |    |    |    |    |    |    |    |    |    |    |    |    |    |    |    |    |    |    |    |    |    |    |    |    |    |    |    |    |    |    |    |    |    |    |    |    |  |
| 11            | 60  | 20   |                |       |                             |    |    |    |    |    |    |    |    |    |    |    |    |    |    |    |    |    |    |    |    |    |    |    |    |    |    |    |    |    |    |    |    |    |    |    |    |    |    |    |    |    |    |    |    |    |    |    |    |    |    |    |    |    |    |    |    |    |    |    |    |    |    |    |    |    |    |    |    |    |    |    |    |    |    |    |  |
| 22            | 64  | 28   |                |       |                             |    |    |    |    |    |    |    |    |    |    |    |    |    |    |    |    |    |    |    |    |    |    |    |    |    |    |    |    |    |    |    |    |    |    |    |    |    |    |    |    |    |    |    |    |    |    |    |    |    |    |    |    |    |    |    |    |    |    |    |    |    |    |    |    |    |    |    |    |    |    |    |    |    |    |    |  |
| 20            | 68  | 36   |                |       |                             |    |    |    |    |    |    |    |    |    |    |    |    |    |    |    |    |    |    |    |    |    |    |    |    |    |    |    |    |    |    |    |    |    |    |    |    |    |    |    |    |    |    |    |    |    |    |    |    |    |    |    |    |    |    |    |    |    |    |    |    |    |    |    |    |    |    |    |    |    |    |    |    |    |    |    |  |
| 12            | 72  | 44   |                |       |                             |    |    |    |    |    |    |    |    |    |    |    |    |    |    |    |    |    |    |    |    |    |    |    |    |    |    |    |    |    |    |    |    |    |    |    |    |    |    |    |    |    |    |    |    |    |    |    |    |    |    |    |    |    |    |    |    |    |    |    |    |    |    |    |    |    |    |    |    |    |    |    |    |    |    |    |  |
| 00            | 76  | 52   |                |       |                             |    |    |    |    |    |    |    |    |    |    |    |    |    |    |    |    |    |    |    |    |    |    |    |    |    |    |    |    |    |    |    |    |    |    |    |    |    |    |    |    |    |    |    |    |    |    |    |    |    |    |    |    |    |    |    |    |    |    |    |    |    |    |    |    |    |    |    |    |    |    |    |    |    |    |    |  |
| 13            | 80  | 60   |                |       |                             |    |    |    |    |    |    |    |    |    |    |    |    |    |    |    |    |    |    |    |    |    |    |    |    |    |    |    |    |    |    |    |    |    |    |    |    |    |    |    |    |    |    |    |    |    |    |    |    |    |    |    |    |    |    |    |    |    |    |    |    |    |    |    |    |    |    |    |    |    |    |    |    |    |    |    |  |
| 31            | 84  | 68   |                |       |                             |    |    |    |    |    |    |    |    |    |    |    |    |    |    |    |    |    |    |    |    |    |    |    |    |    |    |    |    |    |    |    |    |    |    |    |    |    |    |    |    |    |    |    |    |    |    |    |    |    |    |    |    |    |    |    |    |    |    |    |    |    |    |    |    |    |    |    |    |    |    |    |    |    |    |    |  |
| 24            | 88  | 76   |                |       |                             |    |    |    |    |    |    |    |    |    |    |    |    |    |    |    |    |    |    |    |    |    |    |    |    |    |    |    |    |    |    |    |    |    |    |    |    |    |    |    |    |    |    |    |    |    |    |    |    |    |    |    |    |    |    |    |    |    |    |    |    |    |    |    |    |    |    |    |    |    |    |    |    |    |    |    |  |
| 25            | 92  | 84   |                |       |                             |    |    |    |    |    |    |    |    |    |    |    |    |    |    |    |    |    |    |    |    |    |    |    |    |    |    |    |    |    |    |    |    |    |    |    |    |    |    |    |    |    |    |    |    |    |    |    |    |    |    |    |    |    |    |    |    |    |    |    |    |    |    |    |    |    |    |    |    |    |    |    |    |    |    |    |  |
| 26            | 96  | 92   |                |       |                             |    |    |    |    |    |    |    |    |    |    |    |    |    |    |    |    |    |    |    |    |    |    |    |    |    |    |    |    |    |    |    |    |    |    |    |    |    |    |    |    |    |    |    |    |    |    |    |    |    |    |    |    |    |    |    |    |    |    |    |    |    |    |    |    |    |    |    |    |    |    |    |    |    |    |    |  |
| 27            | 00  | 00   |                |       |                             |    |    |    |    |    |    |    |    |    |    |    |    |    |    |    |    |    |    |    |    |    |    |    |    |    |    |    |    |    |    |    |    |    |    |    |    |    |    |    |    |    |    |    |    |    |    |    |    |    |    |    |    |    |    |    |    |    |    |    |    |    |    |    |    |    |    |    |    |    |    |    |    |    |    |    |  |
| 30            | 04  | 08   |                |       |                             |    |    |    |    |    |    |    |    |    |    |    |    |    |    |    |    |    |    |    |    |    |    |    |    |    |    |    |    |    |    |    |    |    |    |    |    |    |    |    |    |    |    |    |    |    |    |    |    |    |    |    |    |    |    |    |    |    |    |    |    |    |    |    |    |    |    |    |    |    |    |    |    |    |    |    |  |

Table 5-14. RSC CCAs Fault Isolation Tests - Continued

| Step                   | Procedure   | Normal indication  | Fault location   |                |  |         |   |              |   |              |   |        |                    |  |  |
|------------------------|---|--|--|----------------|--|---------|---|--------------|---|--------------|---|--------|--------------------|--|--|
| BACKLIGHTING CIRCUITRY |   |  |  |                |  |         |   |              |   |              |   |        |                    |  |  |
| 21.                    | <p>Turn the RSC panel assembly LIGHT control max CW and set the following switches:</p> <table border="0" data-bbox="207 615 649 987"> <thead> <tr> <th data-bbox="207 615 324 646"><u>SWITCH</u></th> <th data-bbox="500 615 633 646"><u>POSITION</u></th> </tr> </thead> <tbody> <tr> <td data-bbox="207 678 435 709">(SELECT CODE)-</td> <td></td> </tr> <tr> <td data-bbox="207 741 324 772">S5 FCTN</td> <td data-bbox="548 741 565 772">8</td> </tr> <tr> <td data-bbox="207 804 406 835">S6 CONDITION</td> <td data-bbox="548 804 565 835">0</td> </tr> <tr> <td data-bbox="207 867 406 898">S7 CONDITION</td> <td data-bbox="548 867 565 898">1</td> </tr> <tr> <td data-bbox="207 930 308 961">S8 SET</td> <td data-bbox="451 930 641 987">Press momentarily.</td> </tr> </tbody> </table> | <u>SWITCH</u>  | <u>POSITION</u>  | (SELECT CODE)- |  | S5 FCTN | 8 | S6 CONDITION | 0 | S7 CONDITION | 1 | S8 SET | Press momentarily. | <p>RSC panel assembly and digital interface backlighting lights.</p> | <p>Normal indications present: step 23.<br/>Absent: step 22.</p> |
| <u>SWITCH</u>          | <u>POSITION</u>   |  |  |                |  |         |   |              |   |              |   |        |                    |  |  |
| (SELECT CODE)-         |   |  |  |                |  |         |   |              |   |              |   |        |                    |  |  |
| S5 FCTN                | 8   |  |  |                |  |         |   |              |   |              |   |        |                    |  |  |
| S6 CONDITION           | 0   |  |  |                |  |         |   |              |   |              |   |        |                    |  |  |
| S7 CONDITION           | 1   |  |  |                |  |         |   |              |   |              |   |        |                    |  |  |
| S8 SET                 | Press momentarily.  |  |  |                |  |         |   |              |   |              |   |        |                    |  |  |
| 22.                    | <p>Connect oscilloscope to digital interface TPs 1 through 8 in turn.</p>   | <p>Oscilloscope indicates:</p> <p>TP1 - 0 VDC<br/>                     TP2 - 0 VDC<br/>                     TP3 - one positive going pulse 8.4 V p-p and 4 ms width.<br/>                     TP4 - 0 VDC<br/>                     TP5 - 8.2 VDC level<br/>                     TP6 - Same as TP3<br/>                     TP7 - Same as TP3<br/>                     TP8 - one negative going pulse -8.4 VDC, 4 ms width.</p> | <p>Present: U17, U15<br/>Absent: U14.</p>                        |                |  |         |   |              |   |              |   |        |                    |  |  |
| 23.                    | <p>Vary RSC panel assembly LIGHT control from max CW to max CCW.</p>  | <p>RSC panel assembly and digital interface assembly lighting varies from max intensity to off.</p>  | <p>Normal indication: step 24.<br/>Incorrect indication: Q3.</p> |                |  |         |   |              |   |              |   |        |                    |  |  |

Table 5-14. RSC CCAs Fault Isolation Tests - Continued

| Step                 | Procedure  | Normal indication  | Fault location   |
|----------------------|--|--|--|
| EPROM STATE CIRCUITS |  |  |  |
|                      |  | <b>NOTE</b>  |  |
|                      |  | Step 24 will take approximately one minute to perform. The first change will take approximately 30 seconds after switches are held.                              |  |
| 24.                  | Press and hold S16 CLOCK switch in the SLOW position while pressing the 2 key on the RSC panel assembly keyboard. Hold both (switch and key) until PRESENT OCTAL STATE display cycles from 37 to 37 again, then release. CR19 blinks on and off. | PRESENT OCTAL STATE display cycles and shows 37, 36, 35, 34, 33, 32, 31, 30, 27, 26, 25, 24, 23, 22, 21, 20, 17, 16, 15, 35, 34, 33, 32, 31, 30, 27, 26, and 37. | Normal indication: step 31.<br>Incorrect indication: step 25.  |
| 24.1.                | Refer to table 5-15 and set the RSC Test Set SELECT CODE switches S5, S6, and S7 as listed.  | Per table 5-15.  | U41 and associated circuitry.  |
| 25.                  | Connect oscilloscope to TP3s 16 through 21 in turn.  | Oscilloscope indicates:<br><br>TP16 - logic zero<br>TPs 17 through 21 are approximately 8.6 VDC level.   | Normal indication: step 26. Incorrect indication: Ensure correct wiring connection between TPs 17-21 on digital interface and plug J8 on RSC test set. |
| 26.                  | Connect oscilloscope to TP28. Position switches S5, S6, and S7 to DOO (RETX STROBE) and push   | Oscilloscope indicates positive going pulses 5 milliseconds width and 8 V p-p.   | Present: step 27.<br>Absent: U10, U17.   |
| 27.                  | Same as step 26, except connect oscilloscope to TP36.  | Oscilloscope indicates approximately 8.4 VDC level.  | Present: step 28.<br>Absent: U41.  |
| 28.                  | Same as step 26, except connect oscilloscope to TP15.  | Oscilloscope indicates positive going square waves 0.4 milliseconds width and 8 VDC p-p.   | Present: step 29.<br>Absent: U22.  |
| 29.                  | Same as step 26, except connect oscilloscope to TP27.  | Oscilloscope indicates a positive going pulse 0.3 ms 8 V p-p.  | Present: step 30.<br>Absent: U19, U20.   |

Table 5-14. RSC CCAs Fault Isolation Tests - Continued

| Step                    | Procedure   | Normal indication   | Fault location  |
|-------------------------|---|---|---|
| 30.                     | Same as step 26, except connect oscilloscope to TP10. | Oscilloscope indicates a positive going square wave 35 ms width and 8 V p-p.  | Present: step 31.<br>Absent: U44, U45.  |
| 31.                     | Connect oscilloscope to TP23.                         | Oscilloscope indicates greater than +9 VDC level.   | Present: step 32.<br>Absent: U8, U20, resistors R28 through R32, C25, or CR5. |
| PTT COMMAND AND CONTROL |   |   |   |
| 32.                     | Press and hold S17 PUSH TO TALK 1 switch.             | PRESENT OCTAL STATE display shows 01 and RADIO TRANSMIT STATUS PTT CR17 is lit (CR17 off when PTT is released). CR19 COMMAND AND CONTROL DATA PRESENT lights for approximately one second when S17 is pressed, and again when it is released. | Normal indication: step 39.<br>Absent: step 33.                               |



Table 5-14. RSC CCAs Fault Isolation Tests - Continued

| Step | Procedure                                      | Normal indication   | Fault location  |
|------|--|---|---|
| 33.  | Connect oscilloscope to TP1 through 8 in turn. | Oscilloscope indicates intermittent positive going square wave pulses of varying width and 8 V p-p.       | Present: step 38.<br>Absent: step 34.                   |
| 34.  | Connect oscilloscope to TP11.                  | Oscilloscope indicates a 9 V p-p level interrupted by three negative going pulses when S17 is pushed.     | Present: U14.<br>Absent: step 35.                       |
| 35.  | Connect oscilloscope to TP13.                  | Oscilloscope indicates positive going square wave pulses less than 2 milliseconds wide, at least 8 V p-p. | Present: U19<br>Absent: U22, U21.                       |
| 36.  | Connect oscilloscope to TP14.                  | Oscilloscope indicates positive going square wave pulses greater than 6 milliseconds wide and 8 V p-p.    | Present: step 37.<br>Absent: U22, U21.                  |
| 37.  | Connect oscilloscope to TP12.                  | Oscilloscope indicates an approximately 8 VDC level.  | Present: U19.<br>Absent: R22, or +9 VDC.                |
| 38.  | Connect oscilloscope to TP9.                   | Oscilloscope indicates a string of narrow (less than 0.2 milliseconds) positive going pulses 8 V p-p.     | Present: U19, U18, U16, U20 or step 40.<br>Absent: U14. |

Table 5-14. RSC CCAs Fault Isolation Tests - Continued

| Step   | Procedure  | Normal indication   | Fault location  |                   |                    |         |     |         |     |  |  |
|--|--|---|---|-------------------|--------------------|---------|-----|---------|-----|--|--|
| 39.  | <p>Press and hold S18 PUSH TO TALK 2 switch.</p>   | <p>PRESENT OCTAL STATE display shows 02 and RADIO TRANSMIT STATUS PTT CR18 is lit (CR18 off when PTT is released). CR19 COMMAND AND CONTROL DATA PRESENT lights for approximately one second when S18 is pressed and again when it is released.</p> | <p>Normal indication: step 40.<br/>Incorrect indication: step 33.</p> |                   |                    |         |     |         |     |  |  |
| <p>RADIO TRANSMIT STATUS TEST</p>  |  |   |   |                   |                    |         |     |         |     |  |  |
| <p>NOTE</p>  |  |   |   |                   |                    |         |     |         |     |  |  |
| <p>The left and right hand RSC panel RADIO TRANSMIT rotary switches will be referred to as OP1 and OP2 respectively.</p> |  |   |   |                   |                    |         |     |         |     |  |  |
| 40.  | <p>Set the following switches:</p> <p style="text-align: center;">NOTE</p> <p>Unless otherwise indicated, reference designators apply to digital interface CCA.</p> <table border="0" data-bbox="212 1451 699 1724"> <thead> <tr> <th style="text-align: left;"><u>SWITCH</u></th> <th style="text-align: left;"><u>POSITION</u></th> </tr> </thead> <tbody> <tr> <td>S10 DISPLAY RESET</td> <td>Press momentarily.</td> </tr> <tr> <td>RSC OP1</td> <td>OFF</td> </tr> <tr> <td>RSC OP2</td> <td>OFF</td> </tr> </tbody> </table> | <u>SWITCH</u>   | <u>POSITION</u>   | S10 DISPLAY RESET | Press momentarily. | RSC OP1 | OFF | RSC OP2 | OFF |  |  |
| <u>SWITCH</u>  | <u>POSITION</u>  |   |   |                   |                    |         |     |         |     |  |  |
| S10 DISPLAY RESET  | Press momentarily.   |   |   |                   |                    |         |     |         |     |  |  |
| RSC OP1  | OFF  |   |   |                   |                    |         |     |         |     |  |  |
| RSC OP2  | OFF  |   |   |                   |                    |         |     |         |     |  |  |



Table 5-14. RSC CCAs Fault Isolation Tests - Continued

| Step                  | Procedure   | Normal indication | Fault location  |                       |  |                    |                    |                |  |                 |                    |              |   |              |   |              |                    |        |                    |   |  |
|-----------------------|---|-------------------|-----------------|-----------------------|--|--------------------|--------------------|----------------|--|-----------------|--------------------|--------------|---|--------------|---|--------------|--------------------|--------|--------------------|---|--|
| 45.                   | <p>Set the following switches:</p> <table border="0"> <thead> <tr> <th data-bbox="215 464 315 491"><u>SWITCH</u></th> <th data-bbox="553 464 683 491"><u>POSITION</u></th> </tr> </thead> <tbody> <tr> <td colspan="2" data-bbox="215 527 423 554">(RETRANSMIT)-</td> </tr> <tr> <td data-bbox="215 590 509 617">S20 ENABLE/DISABLE</td> <td data-bbox="553 590 743 648">Press momentarily.</td> </tr> <tr> <td colspan="2" data-bbox="215 653 440 680">(SELECT CODE)-</td> </tr> <tr> <td data-bbox="215 716 461 743">S9 MASTER RESET</td> <td data-bbox="553 716 743 774">Press momentarily.</td> </tr> <tr> <td data-bbox="215 810 331 837">S5 FCTN</td> <td data-bbox="553 810 570 837">0</td> </tr> <tr> <td data-bbox="215 873 412 900">S6 CONDITION</td> <td data-bbox="553 873 570 900">0</td> </tr> <tr> <td data-bbox="215 936 412 963">S7 CONDITION</td> <td data-bbox="553 936 570 963">0</td> </tr> <tr> <td data-bbox="215 999 315 1026">S8 SET</td> <td data-bbox="553 999 743 1058">Press momentarily.</td> </tr> </tbody> </table> | <u>SWITCH</u>     | <u>POSITION</u> | (RETRANSMIT)-         |  | S20 ENABLE/DISABLE | Press momentarily. | (SELECT CODE)- |  | S9 MASTER RESET | Press momentarily. | S5 FCTN      | 0 | S6 CONDITION | 0 | S7 CONDITION | 0                  | S8 SET | Press momentarily. | <p>(RETRANSMIT)- CR21 ENABLED LED turns off.</p> <p>RADIO TRANSMIT STATUS COUNT display stops counting.</p> |  |
| <u>SWITCH</u>         | <u>POSITION</u>   |                   |                 |                       |  |                    |                    |                |  |                 |                    |              |   |              |   |              |                    |        |                    |   |  |
| (RETRANSMIT)-         |   |                   |                 |                       |  |                    |                    |                |  |                 |                    |              |   |              |   |              |                    |        |                    |   |  |
| S20 ENABLE/DISABLE    | Press momentarily.  |                   |                 |                       |  |                    |                    |                |  |                 |                    |              |   |              |   |              |                    |        |                    |   |  |
| (SELECT CODE)-        |   |                   |                 |                       |  |                    |                    |                |  |                 |                    |              |   |              |   |              |                    |        |                    |   |  |
| S9 MASTER RESET       | Press momentarily.  |                   |                 |                       |  |                    |                    |                |  |                 |                    |              |   |              |   |              |                    |        |                    |   |  |
| S5 FCTN               | 0   |                   |                 |                       |  |                    |                    |                |  |                 |                    |              |   |              |   |              |                    |        |                    |   |  |
| S6 CONDITION          | 0   |                   |                 |                       |  |                    |                    |                |  |                 |                    |              |   |              |   |              |                    |        |                    |   |  |
| S7 CONDITION          | 0   |                   |                 |                       |  |                    |                    |                |  |                 |                    |              |   |              |   |              |                    |        |                    |   |  |
| S8 SET                | Press momentarily.  |                   |                 |                       |  |                    |                    |                |  |                 |                    |              |   |              |   |              |                    |        |                    |   |  |
| DISPLAYS TEST         |   |                   |                 |                       |  |                    |                    |                |  |                 |                    |              |   |              |   |              |                    |        |                    |   |  |
| 46.                   | <p>Set the following switches:</p> <table border="0"> <thead> <tr> <th data-bbox="215 1272 315 1299"><u>SWITCH</u></th> <th data-bbox="553 1272 683 1299"><u>POSITION</u></th> </tr> </thead> <tbody> <tr> <td colspan="2" data-bbox="215 1335 375 1394">(RSC Panel Assembly)-</td> </tr> <tr> <td data-bbox="228 1430 440 1457">LIGHT control</td> <td data-bbox="553 1430 651 1457">max CW</td> </tr> <tr> <td colspan="2" data-bbox="215 1482 440 1509">(SELECT CODE)-</td> </tr> <tr> <td data-bbox="215 1545 331 1572">S5 FCTN</td> <td data-bbox="553 1545 570 1572">8</td> </tr> <tr> <td data-bbox="215 1608 412 1635">S6 CONDITION</td> <td data-bbox="553 1608 570 1635">0</td> </tr> <tr> <td data-bbox="215 1671 412 1698">S7 CONDITION</td> <td data-bbox="553 1671 570 1698">1</td> </tr> <tr> <td data-bbox="215 1734 315 1761">S8 SET</td> <td data-bbox="553 1734 699 1793">Press and release.</td> </tr> </tbody> </table>  | <u>SWITCH</u>     | <u>POSITION</u> | (RSC Panel Assembly)- |  | LIGHT control      | max CW             | (SELECT CODE)- |  | S5 FCTN         | 8                  | S6 CONDITION | 0 | S7 CONDITION | 1 | S8 SET       | Press and release. |        |                    |   |  |
| <u>SWITCH</u>         | <u>POSITION</u>   |                   |                 |                       |  |                    |                    |                |  |                 |                    |              |   |              |   |              |                    |        |                    |   |  |
| (RSC Panel Assembly)- |   |                   |                 |                       |  |                    |                    |                |  |                 |                    |              |   |              |   |              |                    |        |                    |   |  |
| LIGHT control         | max CW  |                   |                 |                       |  |                    |                    |                |  |                 |                    |              |   |              |   |              |                    |        |                    |   |  |
| (SELECT CODE)-        |   |                   |                 |                       |  |                    |                    |                |  |                 |                    |              |   |              |   |              |                    |        |                    |   |  |
| S5 FCTN               | 8   |                   |                 |                       |  |                    |                    |                |  |                 |                    |              |   |              |   |              |                    |        |                    |   |  |
| S6 CONDITION          | 0   |                   |                 |                       |  |                    |                    |                |  |                 |                    |              |   |              |   |              |                    |        |                    |   |  |
| S7 CONDITION          | 1   |                   |                 |                       |  |                    |                    |                |  |                 |                    |              |   |              |   |              |                    |        |                    |   |  |
| S8 SET                | Press and release.  |                   |                 |                       |  |                    |                    |                |  |                 |                    |              |   |              |   |              |                    |        |                    |   |  |

Table 5-14. RSC CCAs Fault Isolation Tests - Continued

| Step | Procedure   | Normal indication  | Fault location |
|------|---|--|----------------|
| 47.  | <p>Set S6 and S7 SELECT CODE switches to the following codes and press and release S8 SELECT CODE switch for each code.</p> | <p>Decimal point of the HF, UHF-AM, and VHF-AM displays will be on. All LCD segments will be off unless specified as on.</p> |                |
|      | <p>SELECT CODE<br/>SWITCH POSITIONS</p>   | <p>Digital interface LCD DISPLAY shows;</p>  |                |
|      | <p>-- -- --</p>   |  |                |
|      | <p>S5 S6 S7</p>   |  |                |
|      | <p>-- -- --</p>   |  |                |
|      | <p>0 0 8 - - - - -</p>  | <p>All digits and legend, and all displays on.</p>   |                |
|      | <p>0 0 4 - - - - -</p>  | <p>All displays blank.</p>   |                |
|      | <p>0 0 C - - - - -</p>  | <p>Displays show all 0's.</p>  |                |
|      | <p>0 1 0 - - - - -</p>  | <p>Displays show all 1's.</p>  |                |
|      | <p>0 1 4 - - - - -</p>  | <p>Displays show all 2's.</p>  |                |
|      | <p>0 1 8 - - - - -</p>  | <p>Displays show all 3's.</p>  |                |
|      | <p>0 1 C - - - - -</p>  | <p>Displays show all 4's.</p>  |                |
|      | <p>1 0 0 - - - - -</p>  | <p>Displays show all 5's.</p>  |                |
|      | <p>1 0 4 - - - - -</p>  | <p>Displays show all 6's.</p>  |                |

Table 5-14. RSC CCAs Fault Isolation Tests - Continued

| Step         | Procedure |   |             | Normal indication                        | Fault location  |
|--------------|-----------|---|-------------|--|---|
| 47.<br>cont. | 1         | 0 | 8 - - - - - | Displays show all 7's.                   |   |
|              | 1         | 0 | C - - - - - | Displays show all 8's.                   |   |
|              | 1         | 1 | 0 - - - - - | Displays show all 9's.                   |   |
|              | 1         | 1 | 4 - - - - - | Displays show all F's.                   |   |
|              | 2         | 0 | 0 - - - - - | 3rd digit HF, UHF-AM, VHF-AM displays 8. | Normal indication: step 48.<br>Incorrect indications: U14, U17, U16, U18. |
|              | 4         | 0 | 0 - - - - - | 2nd digit HF display, center segment on. |   |
|              | 0         | 0 | 0 - - - - - | All segments blank.                      |   |

TEST SET AUDIO RETRANSMIT TEST - RSC OPR 1 AUDIO CHANNELS

|      |   |  |  |  |  |
|------|---|--|--|--|--|
| 48.  | Adjust audio generator for 500 +/- 20 Hz, 6.0 +/- 1.0 V p-p (period of 1.61 to 1.72 ms) and connect to (TEST SET AUDIO) - J8 TRANSMIT jack. |  |  |  |  |
| 48.1 | Connect oscilloscope prob to (TEST SET AUDIO) - J9 RECEIVE.   |  |  |  | Sine wave of 6.0 +/- 1.0 V p-p upon which is riding the digitized audio. |
| 48.2 | Rotate URSC OP1 and OP2 MSTR VOLUME, IC, VHF-FM, UHF-AM, VHF-AM, and HF volume controls to max CW position.                                 |  |  |  |  |
|      | NOTE  |  |  |  |  |
|      | Unless otherwise indicated, reference designators apply to digital interface CCA.   |  |  |  |  |

Table 5-14. RSC CCAs Fault Isolation Tests - Continued

| Step                | Procedure  | Normal indication  | Fault location  |  |                   |  |  |                     |          |                    |          |    |                     |                 |        |          |         |        |   |   |   |  |              |   |  |        |                    |  |  |  |
|---------------------|--|--|---|--|-------------------|--|--|---------------------|----------|--------------------|----------|----|---------------------|-----------------|--------|----------|---------|--------|---|---|---|--|--------------|---|--|--------|--------------------|--|--|--|
| 49.                 | <p>Set the following switches:</p> <table border="0"> <thead> <tr> <th><u>SWITCH</u></th> <th colspan="2"><u>POSITION</u></th> </tr> </thead> <tbody> <tr> <td>(TEST SET AUDIO)-</td> <td></td> <td></td> </tr> <tr> <td>S24 TRANSMIT SELECT</td> <td>IC</td> <td></td> </tr> <tr> <td>URSC OP1</td> <td>IC</td> <td></td> </tr> <tr> <td>(SELECT CODE) -</td> <td></td> <td></td> </tr> <tr> <td>S5 FCTN</td> <td>9</td> <td></td> </tr> <tr> <td>S6 CONDITION</td> <td>0</td> <td></td> </tr> <tr> <td>S7 CONDITION</td> <td>1</td> <td></td> </tr> <tr> <td>S8 SET</td> <td>Press momentarily.</td> <td></td> </tr> </tbody> </table> | <u>SWITCH</u>  | <u>POSITION</u>   |  | (TEST SET AUDIO)- |  |  | S24 TRANSMIT SELECT | IC       |                    | URSC OP1 | IC |                     | (SELECT CODE) - |        |          | S5 FCTN | 9      |   | S6 CONDITION  | 0 |  | S7 CONDITION | 1 |  | S8 SET | Press momentarily. |  | <p>(URSC AUDIO) - J14 RECEIVE jack is greater than or equal to 20.0 V p-p.</p> | <p>Normal indication: step 50.<br/>                     Incorrect indication: U11, U40, R141, R139, U38, U37, U36, U11, U13, U24 or U25.</p> |
| <u>SWITCH</u>       | <u>POSITION</u>  |  |   |  |                   |  |  |                     |          |                    |          |    |                     |                 |        |          |         |        |   |   |   |  |              |   |  |        |                    |  |  |  |
| (TEST SET AUDIO)-   |  |  |   |  |                   |  |  |                     |          |                    |          |    |                     |                 |        |          |         |        |   |   |   |  |              |   |  |        |                    |  |  |  |
| S24 TRANSMIT SELECT | IC   |  |   |  |                   |  |  |                     |          |                    |          |    |                     |                 |        |          |         |        |   |   |   |  |              |   |  |        |                    |  |  |  |
| URSC OP1            | IC   |  |   |  |                   |  |  |                     |          |                    |          |    |                     |                 |        |          |         |        |   |   |   |  |              |   |  |        |                    |  |  |  |
| (SELECT CODE) -     |  |  |   |  |                   |  |  |                     |          |                    |          |    |                     |                 |        |          |         |        |   |   |   |  |              |   |  |        |                    |  |  |  |
| S5 FCTN             | 9  |  |   |  |                   |  |  |                     |          |                    |          |    |                     |                 |        |          |         |        |   |   |   |  |              |   |  |        |                    |  |  |  |
| S6 CONDITION        | 0  |  |   |  |                   |  |  |                     |          |                    |          |    |                     |                 |        |          |         |        |   |   |   |  |              |   |  |        |                    |  |  |  |
| S7 CONDITION        | 1  |  |   |  |                   |  |  |                     |          |                    |          |    |                     |                 |        |          |         |        |   |   |   |  |              |   |  |        |                    |  |  |  |
| S8 SET              | Press momentarily.   |  |   |  |                   |  |  |                     |          |                    |          |    |                     |                 |        |          |         |        |   |   |   |  |              |   |  |        |                    |  |  |  |
| 50.                 | <p>Adjust RSC IC VOL (or respective) control from max CW to max CCW.</p>   | <p>(URSC AUDIO) - J14 RECEIVE jack gradually decreases to &lt; 1.0 Vrms.</p> | <p>Normal indication: step 51.<br/>                     Incorrect indication: switch or wiring.</p> |  |                   |  |  |                     |          |                    |          |    |                     |                 |        |          |         |        |   |   |   |  |              |   |  |        |                    |  |  |  |
| 51.                 | <p>Return RSC IC VOL (or respective) control to max CW position and rotate (TEST SET AUDIO) S24 TRANSMIT SELECT switch through the remaining positions.</p>  | <p>(URSC AUDIO) - J14 RECEIVE jack less than or equal to 2.0 Vrms.</p>       | <p>Normal indication: step 52.<br/>                     Incorrect indication: U11, U13.</p>         |  |                   |  |  |                     |          |                    |          |    |                     |                 |        |          |         |        |   |   |   |  |              |   |  |        |                    |  |  |  |
| 52.                 | <p>Repeat step 49-51 and substitute the following switches and controls for each RSC system operator (A-D):</p> <table border="0"> <thead> <tr> <th rowspan="2"><u>SWITCH</u></th> <th colspan="2"><u>POSITION</u></th> </tr> <tr> <th colspan="2"><u>SYSTEM</u></th> </tr> <tr> <td></td> <th><u>A</u></th> <th><u>B</u></th> </tr> </thead> <tbody> <tr> <td>(TEST SET AUDIO) -</td> <td></td> <td></td> </tr> <tr> <td>S24 TRANSMIT SELECT</td> <td>VHF-FM</td> <td>UHF-AM</td> </tr> <tr> <td>URSC OP1</td> <td>VHF-FM</td> <td>UHF-AM</td> </tr> </tbody> </table>  | <u>SWITCH</u>  | <u>POSITION</u>   |  | <u>SYSTEM</u>     |  |  | <u>A</u>            | <u>B</u> | (TEST SET AUDIO) - |          |    | S24 TRANSMIT SELECT | VHF-FM          | UHF-AM | URSC OP1 | VHF-FM  | UHF-AM | <p>Same as steps 49-51 for each system (A-D). indication:</p> | <p>Normal indication: step 53.<br/>                     Incorrect<br/>                     VHF-FM U28, U31<br/>                     UHF-AM U25, U26<br/>                     VHF-AM U27, U28<br/>                     HF U29, U30</p> |   |  |              |   |  |        |                    |  |  |  |
| <u>SWITCH</u>       | <u>POSITION</u>  |  |   |  |                   |  |  |                     |          |                    |          |    |                     |                 |        |          |         |        |   |   |   |  |              |   |  |        |                    |  |  |  |
|                     | <u>SYSTEM</u>  |  |   |  |                   |  |  |                     |          |                    |          |    |                     |                 |        |          |         |        |   |   |   |  |              |   |  |        |                    |  |  |  |
|                     | <u>A</u>   | <u>B</u>   |   |  |                   |  |  |                     |          |                    |          |    |                     |                 |        |          |         |        |   |   |   |  |              |   |  |        |                    |  |  |  |
| (TEST SET AUDIO) -  |  |  |   |  |                   |  |  |                     |          |                    |          |    |                     |                 |        |          |         |        |   |   |   |  |              |   |  |        |                    |  |  |  |
| S24 TRANSMIT SELECT | VHF-FM   | UHF-AM   |   |  |                   |  |  |                     |          |                    |          |    |                     |                 |        |          |         |        |   |   |   |  |              |   |  |        |                    |  |  |  |
| URSC OP1            | VHF-FM   | UHF-AM   |   |  |                   |  |  |                     |          |                    |          |    |                     |                 |        |          |         |        |   |   |   |  |              |   |  |        |                    |  |  |  |

Table 5-14. RSC CCAs Fault Isolation Tests - Continued

| Step                     | Procedure   | Normal indication  | Fault location  |   |              |   |   |              |   |   |        |                   |  |  |          |          |                     |        |    |         |        |    |         |   |   |              |   |   |              |   |   |        |                                    |  |  |  |
|--------------------------|---|--|---|---|--------------|---|---|--------------|---|---|--------|-------------------|--|--|----------|----------|---------------------|--------|----|---------|--------|----|---------|---|---|--------------|---|---|--------------|---|---|--------|------------------------------------|--|--|--|
| 52.<br>cont.             | <p>(SELECT CODE) -</p> <table border="0"> <tr> <td>S5 FCTN</td> <td>9</td> <td>9</td> </tr> <tr> <td>S6 CONDITION</td> <td>0</td> <td>0</td> </tr> <tr> <td>S7 CONDITION</td> <td>2</td> <td>3</td> </tr> <tr> <td>S8 SET</td> <td>Press momentarily</td> <td></td> </tr> <tr> <td></td> <td><u>C</u></td> <td><u>D</u></td> </tr> </table> <p>(TEST SET AUDIO) -</p> <table border="0"> <tr> <td>S24 TRANSMIT SELECT</td> <td>VHF-AM</td> <td>HF</td> </tr> <tr> <td>RSC OP1</td> <td>VHF-AM</td> <td>HF</td> </tr> </table> <p>(SELECT CODE) -</p> <table border="0"> <tr> <td>S5 FCTN</td> <td>9</td> <td>9</td> </tr> <tr> <td>S6 CONDITION</td> <td>0</td> <td>0</td> </tr> <tr> <td>S7 CONDITION</td> <td>4</td> <td>5</td> </tr> <tr> <td>S8 SET</td> <td>Press momentarily for each system.</td> <td></td> </tr> </table> | S5 FCTN  | 9   | 9 | S6 CONDITION | 0 | 0 | S7 CONDITION | 2 | 3 | S8 SET | Press momentarily |  |  | <u>C</u> | <u>D</u> | S24 TRANSMIT SELECT | VHF-AM | HF | RSC OP1 | VHF-AM | HF | S5 FCTN | 9 | 9 | S6 CONDITION | 0 | 0 | S7 CONDITION | 4 | 5 | S8 SET | Press momentarily for each system. |  |  |  |
| S5 FCTN                  | 9   | 9  |   |   |              |   |   |              |   |   |        |                   |  |  |          |          |                     |        |    |         |        |    |         |   |   |              |   |   |              |   |   |        |                                    |  |  |  |
| S6 CONDITION             | 0   | 0  |   |   |              |   |   |              |   |   |        |                   |  |  |          |          |                     |        |    |         |        |    |         |   |   |              |   |   |              |   |   |        |                                    |  |  |  |
| S7 CONDITION             | 2   | 3  |   |   |              |   |   |              |   |   |        |                   |  |  |          |          |                     |        |    |         |        |    |         |   |   |              |   |   |              |   |   |        |                                    |  |  |  |
| S8 SET                   | Press momentarily   |  |   |   |              |   |   |              |   |   |        |                   |  |  |          |          |                     |        |    |         |        |    |         |   |   |              |   |   |              |   |   |        |                                    |  |  |  |
|                          | <u>C</u>  | <u>D</u>   |   |   |              |   |   |              |   |   |        |                   |  |  |          |          |                     |        |    |         |        |    |         |   |   |              |   |   |              |   |   |        |                                    |  |  |  |
| S24 TRANSMIT SELECT      | VHF-AM  | HF   |   |   |              |   |   |              |   |   |        |                   |  |  |          |          |                     |        |    |         |        |    |         |   |   |              |   |   |              |   |   |        |                                    |  |  |  |
| RSC OP1                  | VHF-AM  | HF   |   |   |              |   |   |              |   |   |        |                   |  |  |          |          |                     |        |    |         |        |    |         |   |   |              |   |   |              |   |   |        |                                    |  |  |  |
| S5 FCTN                  | 9   | 9  |   |   |              |   |   |              |   |   |        |                   |  |  |          |          |                     |        |    |         |        |    |         |   |   |              |   |   |              |   |   |        |                                    |  |  |  |
| S6 CONDITION             | 0   | 0  |   |   |              |   |   |              |   |   |        |                   |  |  |          |          |                     |        |    |         |        |    |         |   |   |              |   |   |              |   |   |        |                                    |  |  |  |
| S7 CONDITION             | 4   | 5  |   |   |              |   |   |              |   |   |        |                   |  |  |          |          |                     |        |    |         |        |    |         |   |   |              |   |   |              |   |   |        |                                    |  |  |  |
| S8 SET                   | Press momentarily for each system.  |  |   |   |              |   |   |              |   |   |        |                   |  |  |          |          |                     |        |    |         |        |    |         |   |   |              |   |   |              |   |   |        |                                    |  |  |  |
| 53.                      | Adjust URSC OP1 MASTER VOL control from max CW to max CCW.  | (RSC AUDIO) - J14 RECEIVE jack gradually decreases from greater than or equal to 20.0 V p-p max to < 1.0 V Vrms minimum. | Normal indication: step 54.<br>Incorrect indications: switch or wiring.                           |   |              |   |   |              |   |   |        |                   |  |  |          |          |                     |        |    |         |        |    |         |   |   |              |   |   |              |   |   |        |                                    |  |  |  |
| RSC OPR 2 AUDIO CHANNELS |   |  |   |   |              |   |   |              |   |   |        |                   |  |  |          |          |                     |        |    |         |        |    |         |   |   |              |   |   |              |   |   |        |                                    |  |  |  |
| 54.                      | Connect oscilloscope probe to J15 of TS-4133. Set the following switches and controls for each system (A-E). Also adjust RSC VOL control from max CW to max CCW for each system.  | (URSC AUDIO) - RECEIVE jack greater than or equal to 20.0 V p-p for each system (A-E).                                   | Normal indication: step 55.<br>Incorrect indication:<br>IC, U35, R132, R130, R134, U34, U33, U32. |   |              |   |   |              |   |   |        |                   |  |  |          |          |                     |        |    |         |        |    |         |   |   |              |   |   |              |   |   |        |                                    |  |  |  |



Table 5-14. RSC CCAs Fault Isolation Tests - Continued

| Step         | Procedure  | Normal indication   | Fault location  |
|--------------|--|---|---|
| 54.<br>cont. | <p><u>SWITCH</u>                      <u>POSITION</u></p> <p>   SYSTEM</p> <p>   <u>A</u>   <u>B</u>   <u>C</u></p> <p>(TEST SET AUDIO) -</p> <p>S24 TRANSMIT    IC   VHF- UHF-<br/>SELECT                      FM   AM</p> <p>RSC OP2                      IC   VHF- UHF-<br/>   FM   AM</p> <p>(SELECT CODE) -</p> <p>S5 FCTN                      9    9    9</p> <p>S6 CONDITION              0    0    0</p> <p>S7 CONDITION              6    7    8</p> <p>S8 SET                      Press<br/>   momentarily<br/>   for each system.</p> <p>   <u>D</u>    <u>E</u></p> <p>(TEST SET AUDIO) -</p> <p>S24 TRANSMIT              VHF- HF<br/>SELECT                      AM</p> <p>RSC OP2                      VHF- HF<br/>   AM</p> <p>(SELECT CODE) -</p> <p>S5 FCTN                      9            9</p> <p>S6 CONDITION              0            0</p> <p>S7 CONDITION              9            A</p> <p>S8 SET                      Press<br/>   momentarily.</p> |   | <p>VHF-FM U28, U31.</p> <p>UHF-AM U25, U26.</p> <p>VHF-AM U27, U28.</p> <p>HF U29, U30.</p> |
| 55.          | Adjust RSC OP2 MASTER VOL control from max CW to max CCW.  | (URSC AUDIO) - J15 RECEIVE jack gradually decreases from greater than or equal to 20.0 V p-p to < 1.0 Vrms. | Normal indication: step 56.<br>Incorrect indication: switch or wiring.                      |



Table 5-14. RSC GCAs Fault Isolation Tests - Continued

| Step                | Procedure  | Normal indication  | Fault location   |                    |  |                     |    |                |  |         |   |              |   |              |   |        |                    |                |  |                     |             |                 |        |  |  |
|---------------------|--|--|--|--------------------|--|---------------------|----|----------------|--|---------|---|--------------|---|--------------|---|--------|--------------------|----------------|--|---------------------|-------------|-----------------|--------|--|--|
| <b>SPEAKER TEST</b> |  |  |  |                    |  |                     |    |                |  |         |   |              |   |              |   |        |                    |                |  |                     |             |                 |        |  |  |
| 56.                 | Adjust the audio generator for 400 +/- 20 Hz and 6.0 +/- 1.0 V p-p.  |  |  |                    |  |                     |    |                |  |         |   |              |   |              |   |        |                    |                |  |                     |             |                 |        |  |  |
| 57.                 | <p>Set the following switches:</p> <table border="0" style="width: 100%;"> <tr> <td style="text-align: left;"><u>SWITCH</u></td> <td style="text-align: left;"><u>POSITION</u></td> </tr> <tr> <td colspan="2">(TEST SET AUDIO) -</td> </tr> <tr> <td>S24 TRANSMIT SELECT</td> <td>IC</td> </tr> <tr> <td colspan="2">(SELECT CODE)-</td> </tr> <tr> <td>S5 FCTN</td> <td>9</td> </tr> <tr> <td>S6 CONDITION</td> <td>0</td> </tr> <tr> <td>S7 CONDITION</td> <td>B</td> </tr> <tr> <td>S8 SET</td> <td>Press momentarily.</td> </tr> <tr> <td colspan="2">(SPEAKER)- S14</td> </tr> <tr> <td>OUTPUT LOAD/SPEAKER</td> <td>OUTPUT LOAD</td> </tr> <tr> <td>RSC SPKR VOLUME</td> <td>max CW</td> </tr> </table> | <u>SWITCH</u>  | <u>POSITION</u>  | (TEST SET AUDIO) - |  | S24 TRANSMIT SELECT | IC | (SELECT CODE)- |  | S5 FCTN | 9 | S6 CONDITION | 0 | S7 CONDITION | B | S8 SET | Press momentarily. | (SPEAKER)- S14 |  | OUTPUT LOAD/SPEAKER | OUTPUT LOAD | RSC SPKR VOLUME | max CW |  |  |
| <u>SWITCH</u>       | <u>POSITION</u>  |  |  |                    |  |                     |    |                |  |         |   |              |   |              |   |        |                    |                |  |                     |             |                 |        |  |  |
| (TEST SET AUDIO) -  |  |  |  |                    |  |                     |    |                |  |         |   |              |   |              |   |        |                    |                |  |                     |             |                 |        |  |  |
| S24 TRANSMIT SELECT | IC   |  |  |                    |  |                     |    |                |  |         |   |              |   |              |   |        |                    |                |  |                     |             |                 |        |  |  |
| (SELECT CODE)-      |  |  |  |                    |  |                     |    |                |  |         |   |              |   |              |   |        |                    |                |  |                     |             |                 |        |  |  |
| S5 FCTN             | 9  |  |  |                    |  |                     |    |                |  |         |   |              |   |              |   |        |                    |                |  |                     |             |                 |        |  |  |
| S6 CONDITION        | 0  |  |  |                    |  |                     |    |                |  |         |   |              |   |              |   |        |                    |                |  |                     |             |                 |        |  |  |
| S7 CONDITION        | B  |  |  |                    |  |                     |    |                |  |         |   |              |   |              |   |        |                    |                |  |                     |             |                 |        |  |  |
| S8 SET              | Press momentarily.   |  |  |                    |  |                     |    |                |  |         |   |              |   |              |   |        |                    |                |  |                     |             |                 |        |  |  |
| (SPEAKER)- S14      |  |  |  |                    |  |                     |    |                |  |         |   |              |   |              |   |        |                    |                |  |                     |             |                 |        |  |  |
| OUTPUT LOAD/SPEAKER | OUTPUT LOAD  |  |  |                    |  |                     |    |                |  |         |   |              |   |              |   |        |                    |                |  |                     |             |                 |        |  |  |
| RSC SPKR VOLUME     | max CW   |  |  |                    |  |                     |    |                |  |         |   |              |   |              |   |        |                    |                |  |                     |             |                 |        |  |  |
| 58.                 | Connect the audio generator to (TEST SET AUDIO)- J8 TRANSMIT jack. Using DVM, measure between (SPEAKER)- OUTPUT J2-A AND J3-B.   | Greater than or equal to 4.0 Vrms.   | Normal indication: step 59.  |                    |  |                     |    |                |  |         |   |              |   |              |   |        |                    |                |  |                     |             |                 |        |  |  |
| 59.                 | Set RSC Panel Assembly SPKR MUTE/ON switch to the ON position and press and release S17 PUSH TO TALK 1 switch.   | (SPEAKER)- OUTPUT between J2 (A) and J3 (B) greater than or equal to 4.0 Vrms. | Normal indication: step 60.<br>Incorrect indication: RSC panel switch SW2 or wiring. |                    |  |                     |    |                |  |         |   |              |   |              |   |        |                    |                |  |                     |             |                 |        |  |  |

Table 5-14. RSC CCAs Fault Isolation Tests - Continued

| Step  | Procedure   | Normal indication  | Fault location  |
|---|---|--|---|
| 60.   | Set RSC Panel Assembly SPKR MUTE/ON switch to the MUTE position and press and hold S17 PUSH TO TALK 1 switch (release S17 after measurement).                                     | (SPEAKER)- OUTPUT between J2 (A) and J3 (B) < 0.4 Vrms.                        | Normal indication: step 61.<br>Incorrect indication: U39, R136, Q7 or C202.               |
| 61.   | Gradually adjust RSC Panel Assembly SPKR VOLUME control from max CW to max CCW.   | (SPEAKER)- OUTPUT between J2 (A) and J3 (B) gradually decreases to < 0.4 Vrms. | Normal indication: step 62.<br>Incorrect indication: RSC R9 or wiring.                    |
| 62.   | Adjust RSC Panel Assembly SPKR VOLUME control for 1.0 +/- 0.3 Vrms between (SPEAKER)- OUTPUT J2 (A) and J3 (B).   |  |   |
| 63.   | Set (SPEAKER)- S14 OUTPUT/LOAD SPEAKER switch to SPEAKER (return to LOAD position after measurement is complete).   | (SPEAKER)- OUTPUT between J2 (A) and J3 (B) = 1.0 +/- 0.3 Vrms.                | Normal indication: step 64.<br>Incorrect indication: RSC SPKR VOLUME switch R9 or wiring. |
| AUDIO RECEIVE TEST - OPR 1 CHANNELS                                 |   |  |   |
| NOTE  |   |  |   |
| Disconnect the audio generator ground strap for the following test. |   |  |   |
| 64.   | Adjust audio generator for 600 +/- 20 Hz, 1.13 +/- 0.11 V p-p (period of 1.61 - 1.72 milliseconds) and connect generator to (URSC AUDIO) - TRANSMIT OPERATOR 1 J10 AND J11 jacks. |  |   |

Table 5-14. RSC CCAs Fault Isolation Tests - Continued

| Step               | Procedure   | Normal indication | Fault location     |        |  |  |  |  |   |   |   |                    |  |  |  |  |                    |    |        |        |  |         |    |        |        |  |                |  |  |  |  |         |   |   |   |  |              |   |   |   |  |              |   |   |   |  |        |                                    |  |  |  |                  |                 |  |                    |  |  |  |
|--------------------|---|-------------------|--------------------|--------|--|--|--|--|---|---|---|--------------------|--|--|--|--|--------------------|----|--------|--------|--|---------|----|--------|--------|--|----------------|--|--|--|--|---------|---|---|---|--|--------------|---|---|---|--|--------------|---|---|---|--|--------|------------------------------------|--|--|--|------------------|-----------------|--|--------------------|--|--|--|
| 65.                | Connect scope to (TEST SET AUDIO)-J9 RECEIVE jack.  |                   |                    |        |  |  |  |  |   |   |   |                    |  |  |  |  |                    |    |        |        |  |         |    |        |        |  |                |  |  |  |  |         |   |   |   |  |              |   |   |   |  |              |   |   |   |  |        |                                    |  |  |  |                  |                 |  |                    |  |  |  |
| 66.                | <p>Set the following switches and controls for each system (A-E) starting with IC.</p> <table border="0"> <thead> <tr> <th data-bbox="321 621 418 646"><u>SWITCH</u></th> <th data-bbox="545 621 675 646"><u>POSITION</u></th> <th colspan="3" data-bbox="561 680 659 705">SYSTEM</th> </tr> <tr> <td></td> <td></td> <th data-bbox="561 743 581 768">A</th> <th data-bbox="626 743 646 768">B</th> <th data-bbox="708 743 727 768">C</th> </tr> </thead> <tbody> <tr> <td colspan="5" data-bbox="321 806 607 831">(TEST SET AUDIO) -</td> </tr> <tr> <td data-bbox="321 865 500 919">S25 RECEIVE SELECT</td> <td data-bbox="561 865 597 890">IC</td> <td data-bbox="626 865 688 919">VHF-FM</td> <td data-bbox="708 865 769 919">UHF-AM</td> <td></td> </tr> <tr> <td data-bbox="321 957 435 982">RSC OP2</td> <td data-bbox="561 957 597 982">IC</td> <td data-bbox="626 957 688 1012">VHF-FM</td> <td data-bbox="708 957 769 1012">UHF-AM</td> <td></td> </tr> <tr> <td colspan="5" data-bbox="321 1050 542 1075">(SELECT CODE)-</td> </tr> <tr> <td data-bbox="321 1113 435 1138">S5 FCTN</td> <td data-bbox="561 1113 581 1138">A</td> <td data-bbox="626 1113 646 1138">A</td> <td data-bbox="708 1113 727 1138">A</td> <td></td> </tr> <tr> <td data-bbox="321 1176 516 1201">S6 CONDITION</td> <td data-bbox="561 1176 581 1201">0</td> <td data-bbox="626 1176 646 1201">0</td> <td data-bbox="708 1176 727 1201">0</td> <td></td> </tr> <tr> <td data-bbox="321 1239 516 1264">S7 CONDITION</td> <td data-bbox="561 1239 581 1264">1</td> <td data-bbox="626 1239 646 1264">2</td> <td data-bbox="708 1239 727 1264">3</td> <td></td> </tr> <tr> <td data-bbox="321 1302 418 1327">S8 SET</td> <td colspan="4" data-bbox="561 1302 753 1386">Press momentarily for each system.</td> </tr> <tr> <td data-bbox="321 1423 500 1478">S17 PUSH TO TALK</td> <td colspan="2" data-bbox="561 1457 711 1507">Press and hold.</td> <td colspan="2" data-bbox="912 1457 1198 1482">4.0 +/- 0.6 V p-p.</td> </tr> </tbody> </table> | <u>SWITCH</u>     | <u>POSITION</u>    | SYSTEM |  |  |  |  | A | B | C | (TEST SET AUDIO) - |  |  |  |  | S25 RECEIVE SELECT | IC | VHF-FM | UHF-AM |  | RSC OP2 | IC | VHF-FM | UHF-AM |  | (SELECT CODE)- |  |  |  |  | S5 FCTN | A | A | A |  | S6 CONDITION | 0 | 0 | 0 |  | S7 CONDITION | 1 | 2 | 3 |  | S8 SET | Press momentarily for each system. |  |  |  | S17 PUSH TO TALK | Press and hold. |  | 4.0 +/- 0.6 V p-p. |  |  |  |
| <u>SWITCH</u>      | <u>POSITION</u>   | SYSTEM            |                    |        |  |  |  |  |   |   |   |                    |  |  |  |  |                    |    |        |        |  |         |    |        |        |  |                |  |  |  |  |         |   |   |   |  |              |   |   |   |  |              |   |   |   |  |        |                                    |  |  |  |                  |                 |  |                    |  |  |  |
|                    |   | A                 | B                  | C      |  |  |  |  |   |   |   |                    |  |  |  |  |                    |    |        |        |  |         |    |        |        |  |                |  |  |  |  |         |   |   |   |  |              |   |   |   |  |              |   |   |   |  |        |                                    |  |  |  |                  |                 |  |                    |  |  |  |
| (TEST SET AUDIO) - |   |                   |                    |        |  |  |  |  |   |   |   |                    |  |  |  |  |                    |    |        |        |  |         |    |        |        |  |                |  |  |  |  |         |   |   |   |  |              |   |   |   |  |              |   |   |   |  |        |                                    |  |  |  |                  |                 |  |                    |  |  |  |
| S25 RECEIVE SELECT | IC  | VHF-FM            | UHF-AM             |        |  |  |  |  |   |   |   |                    |  |  |  |  |                    |    |        |        |  |         |    |        |        |  |                |  |  |  |  |         |   |   |   |  |              |   |   |   |  |              |   |   |   |  |        |                                    |  |  |  |                  |                 |  |                    |  |  |  |
| RSC OP2            | IC  | VHF-FM            | UHF-AM             |        |  |  |  |  |   |   |   |                    |  |  |  |  |                    |    |        |        |  |         |    |        |        |  |                |  |  |  |  |         |   |   |   |  |              |   |   |   |  |              |   |   |   |  |        |                                    |  |  |  |                  |                 |  |                    |  |  |  |
| (SELECT CODE)-     |   |                   |                    |        |  |  |  |  |   |   |   |                    |  |  |  |  |                    |    |        |        |  |         |    |        |        |  |                |  |  |  |  |         |   |   |   |  |              |   |   |   |  |              |   |   |   |  |        |                                    |  |  |  |                  |                 |  |                    |  |  |  |
| S5 FCTN            | A   | A                 | A                  |        |  |  |  |  |   |   |   |                    |  |  |  |  |                    |    |        |        |  |         |    |        |        |  |                |  |  |  |  |         |   |   |   |  |              |   |   |   |  |              |   |   |   |  |        |                                    |  |  |  |                  |                 |  |                    |  |  |  |
| S6 CONDITION       | 0   | 0                 | 0                  |        |  |  |  |  |   |   |   |                    |  |  |  |  |                    |    |        |        |  |         |    |        |        |  |                |  |  |  |  |         |   |   |   |  |              |   |   |   |  |              |   |   |   |  |        |                                    |  |  |  |                  |                 |  |                    |  |  |  |
| S7 CONDITION       | 1   | 2                 | 3                  |        |  |  |  |  |   |   |   |                    |  |  |  |  |                    |    |        |        |  |         |    |        |        |  |                |  |  |  |  |         |   |   |   |  |              |   |   |   |  |              |   |   |   |  |        |                                    |  |  |  |                  |                 |  |                    |  |  |  |
| S8 SET             | Press momentarily for each system.  |                   |                    |        |  |  |  |  |   |   |   |                    |  |  |  |  |                    |    |        |        |  |         |    |        |        |  |                |  |  |  |  |         |   |   |   |  |              |   |   |   |  |              |   |   |   |  |        |                                    |  |  |  |                  |                 |  |                    |  |  |  |
| S17 PUSH TO TALK   | Press and hold.   |                   | 4.0 +/- 0.6 V p-p. |        |  |  |  |  |   |   |   |                    |  |  |  |  |                    |    |        |        |  |         |    |        |        |  |                |  |  |  |  |         |   |   |   |  |              |   |   |   |  |              |   |   |   |  |        |                                    |  |  |  |                  |                 |  |                    |  |  |  |

Table 5-14. RSC CCAs Fault Isolation Tests - Continued

| Step         | Procedure   | Normal indication  | Fault location  |
|--------------|---|--|---|
| 66.<br>cont. | <p>(TEST SET AUDIO) -</p> <p>S25 RECEIVE      VHF-   HF<br/>SELECT            AM</p> <p>RSC OP 2            VHF-   HF<br/>                         AM</p> <p>(SELECT CODE)-</p> <p>S5 FCTN            A      A</p> <p>S6 CONDITION      0      0</p> <p>S7 CONDITION      4      5</p> <p>S8 SET            Press momen-<br/>                         tarily for<br/>                         each system.</p> <p>S17 PUSH           Press and hold<br/>TO TALK 1          for each system.</p> | 4.0 +/- 0.6 V p-p.   | Normal indication:<br>step 67.  |
|              | <p>(TEST SET AUDIO)-</p> <p>S25 RECEIVE      Rotate through<br/>SELECT            remaining four<br/>                         positions (with S17<br/>                         pressed).</p>  | J9 URSC AUDIO<br>RECEIVE jack less<br>than or equal to<br>0.25 Vrms. | Incorrect<br>indication: U11,<br><br>U6, U4, U20, U21,<br>U12, U10, U4 or<br>associated<br>circuitry. |
| 67.          | Connect audio generator to (URSC<br>AUDIO)- TRANSMIT OPERATOR 2 J12 and<br>J13 jacks.   |  |   |

Table 5-14. RSC CCAs Fault Isolation Tests - Continued

| Step               | Procedure   | Normal indication | Fault location  |  |  |  |        |  |  |  |   |   |   |                    |  |  |  |                    |    |        |        |                 |  |  |  |         |   |   |   |              |   |   |   |              |   |   |   |        |                                    |  |  |                  |                                 |  |  |  |   |   |  |                    |  |  |  |                    |        |    |  |                           |  |
|--------------------|---|-------------------|-----------------|--|--|--|--------|--|--|--|---|---|---|--------------------|--|--|--|--------------------|----|--------|--------|-----------------|--|--|--|---------|---|---|---|--------------|---|---|---|--------------|---|---|---|--------|------------------------------------|--|--|------------------|---------------------------------|--|--|--|---|---|--|--------------------|--|--|--|--------------------|--------|----|--|---------------------------|--|
| 68.                | <p>Set the following switches and controls for each system (A-E) starting with IC.</p> <table border="0"> <tr> <td><u>SWITCH</u></td> <td colspan="3"><u>POSITION</u></td> </tr> <tr> <td></td> <td colspan="3">SYSTEM</td> </tr> <tr> <td></td> <td>A</td> <td>B</td> <td>C</td> </tr> <tr> <td colspan="4">(TEST SET AUDIO) -</td> </tr> <tr> <td>S25 RECEIVE SELECT</td> <td>IC</td> <td>VHF-FM</td> <td>UHF-AM</td> </tr> <tr> <td colspan="4">(SELECT CODE) -</td> </tr> <tr> <td>S5 FCTN</td> <td>A</td> <td>A</td> <td>A</td> </tr> <tr> <td>S6 CONDITION</td> <td>0</td> <td>0</td> <td>0</td> </tr> <tr> <td>S7 CONDITION</td> <td>6</td> <td>7</td> <td>8</td> </tr> <tr> <td>S8 SET</td> <td colspan="3">Press momentarily for each system.</td> </tr> <tr> <td>S18 PUSH TO TALK</td> <td colspan="3">Press and hold for each system.</td> </tr> <tr> <td></td> <td>D</td> <td>E</td> <td></td> </tr> <tr> <td colspan="4">(TEST SET AUDIO) -</td> </tr> <tr> <td>S25 RECEIVE SELECT</td> <td>VHF-AM</td> <td>HF</td> <td></td> </tr> </table> | <u>SWITCH</u>     | <u>POSITION</u> |  |  |  | SYSTEM |  |  |  | A | B | C | (TEST SET AUDIO) - |  |  |  | S25 RECEIVE SELECT | IC | VHF-FM | UHF-AM | (SELECT CODE) - |  |  |  | S5 FCTN | A | A | A | S6 CONDITION | 0 | 0 | 0 | S7 CONDITION | 6 | 7 | 8 | S8 SET | Press momentarily for each system. |  |  | S18 PUSH TO TALK | Press and hold for each system. |  |  |  | D | E |  | (TEST SET AUDIO) - |  |  |  | S25 RECEIVE SELECT | VHF-AM | HF |  | <p>4.0 +/- 0.6 V p-p.</p> |  |
| <u>SWITCH</u>      | <u>POSITION</u>   |                   |                 |  |  |  |        |  |  |  |   |   |   |                    |  |  |  |                    |    |        |        |                 |  |  |  |         |   |   |   |              |   |   |   |              |   |   |   |        |                                    |  |  |                  |                                 |  |  |  |   |   |  |                    |  |  |  |                    |        |    |  |                           |  |
|                    | SYSTEM  |                   |                 |  |  |  |        |  |  |  |   |   |   |                    |  |  |  |                    |    |        |        |                 |  |  |  |         |   |   |   |              |   |   |   |              |   |   |   |        |                                    |  |  |                  |                                 |  |  |  |   |   |  |                    |  |  |  |                    |        |    |  |                           |  |
|                    | A   | B                 | C               |  |  |  |        |  |  |  |   |   |   |                    |  |  |  |                    |    |        |        |                 |  |  |  |         |   |   |   |              |   |   |   |              |   |   |   |        |                                    |  |  |                  |                                 |  |  |  |   |   |  |                    |  |  |  |                    |        |    |  |                           |  |
| (TEST SET AUDIO) - |   |                   |                 |  |  |  |        |  |  |  |   |   |   |                    |  |  |  |                    |    |        |        |                 |  |  |  |         |   |   |   |              |   |   |   |              |   |   |   |        |                                    |  |  |                  |                                 |  |  |  |   |   |  |                    |  |  |  |                    |        |    |  |                           |  |
| S25 RECEIVE SELECT | IC  | VHF-FM            | UHF-AM          |  |  |  |        |  |  |  |   |   |   |                    |  |  |  |                    |    |        |        |                 |  |  |  |         |   |   |   |              |   |   |   |              |   |   |   |        |                                    |  |  |                  |                                 |  |  |  |   |   |  |                    |  |  |  |                    |        |    |  |                           |  |
| (SELECT CODE) -    |   |                   |                 |  |  |  |        |  |  |  |   |   |   |                    |  |  |  |                    |    |        |        |                 |  |  |  |         |   |   |   |              |   |   |   |              |   |   |   |        |                                    |  |  |                  |                                 |  |  |  |   |   |  |                    |  |  |  |                    |        |    |  |                           |  |
| S5 FCTN            | A   | A                 | A               |  |  |  |        |  |  |  |   |   |   |                    |  |  |  |                    |    |        |        |                 |  |  |  |         |   |   |   |              |   |   |   |              |   |   |   |        |                                    |  |  |                  |                                 |  |  |  |   |   |  |                    |  |  |  |                    |        |    |  |                           |  |
| S6 CONDITION       | 0   | 0                 | 0               |  |  |  |        |  |  |  |   |   |   |                    |  |  |  |                    |    |        |        |                 |  |  |  |         |   |   |   |              |   |   |   |              |   |   |   |        |                                    |  |  |                  |                                 |  |  |  |   |   |  |                    |  |  |  |                    |        |    |  |                           |  |
| S7 CONDITION       | 6   | 7                 | 8               |  |  |  |        |  |  |  |   |   |   |                    |  |  |  |                    |    |        |        |                 |  |  |  |         |   |   |   |              |   |   |   |              |   |   |   |        |                                    |  |  |                  |                                 |  |  |  |   |   |  |                    |  |  |  |                    |        |    |  |                           |  |
| S8 SET             | Press momentarily for each system.  |                   |                 |  |  |  |        |  |  |  |   |   |   |                    |  |  |  |                    |    |        |        |                 |  |  |  |         |   |   |   |              |   |   |   |              |   |   |   |        |                                    |  |  |                  |                                 |  |  |  |   |   |  |                    |  |  |  |                    |        |    |  |                           |  |
| S18 PUSH TO TALK   | Press and hold for each system.   |                   |                 |  |  |  |        |  |  |  |   |   |   |                    |  |  |  |                    |    |        |        |                 |  |  |  |         |   |   |   |              |   |   |   |              |   |   |   |        |                                    |  |  |                  |                                 |  |  |  |   |   |  |                    |  |  |  |                    |        |    |  |                           |  |
|                    | D   | E                 |                 |  |  |  |        |  |  |  |   |   |   |                    |  |  |  |                    |    |        |        |                 |  |  |  |         |   |   |   |              |   |   |   |              |   |   |   |        |                                    |  |  |                  |                                 |  |  |  |   |   |  |                    |  |  |  |                    |        |    |  |                           |  |
| (TEST SET AUDIO) - |   |                   |                 |  |  |  |        |  |  |  |   |   |   |                    |  |  |  |                    |    |        |        |                 |  |  |  |         |   |   |   |              |   |   |   |              |   |   |   |        |                                    |  |  |                  |                                 |  |  |  |   |   |  |                    |  |  |  |                    |        |    |  |                           |  |
| S25 RECEIVE SELECT | VHF-AM  | HF                |                 |  |  |  |        |  |  |  |   |   |   |                    |  |  |  |                    |    |        |        |                 |  |  |  |         |   |   |   |              |   |   |   |              |   |   |   |        |                                    |  |  |                  |                                 |  |  |  |   |   |  |                    |  |  |  |                    |        |    |  |                           |  |

Table 5-14. RSC CCAs Fault Isolation Tests - Continued

| Step                            | Procedure   | Normal indication  | Fault location   |
|---------------------------------|---|--|--|
| 68.<br>cont.                    | <p>(SELECT CODE)-</p> <p>S5 FCTN           A     A</p> <p>S6 CONDITION     0     0</p> <p>S7 CONDITION     9     A</p> <p>S8 SET            Press momentarily for each system.</p> <p>S18 PUSH TO TALK 2   Press and hold for each system.</p> <p>(TEST SET AUDIO)-</p> <p>S25 RECEIVE SELECT   Rotate through remaining four positions (with S18 pressed).</p> | <p>J9 (TEST SET AUDIO)- RECEIVE jack - 4.0 +/- 0.6 V p-p.</p> <p>J9 URSC AUDIO RECEIVE jack less than or equal to 0.24 Vrms.</p> | <p>Normal indication: step 69.</p> <p>Incorrect indication: U11, U3, U2, U20, U22, U12, U10, U5 or associated circuitry.</p> |
| SPEAKER POWER OFF/ON# LINE TEST |   |  |  |
| 69.                             | <p>Place RSC Panel Assembly SPKR VOLUME control to the OFF position and measure (SPEAKER)- TP9 OFF/ON with a multimeter (use (DC INPUT POWER)- TP1 GND for ground).</p>   | <p>Greater than or equal to 15.0 VDC.</p>  | <p>Normal indication: step 71.<br/>Incorrect indication: step 70.</p>  |
| 70.                             | <p>Place RSC Panel Assembly SPKR VOLUME control to the maximum CW position and measure (SPEAKER) - TP9 OFF/ON with a multimeter. Use (DC INPUT POWER)- TP1 GND for ground.</p>  | <p>Less than 0.5 VDC.</p>  | <p>Normal indication: step 71.<br/>Incorrect indication: U45, U46, Q4, Q14, or associated circuitry.</p>                     |



Table 5-14. RSC CCAs Fault Isolation Tests - Continued

| Step   | Procedure   | Normal indication  | Fault location   |                 |  |                    |  |                 |                    |                |  |                     |                    |                    |  |                     |     |  |          |  |   |
|--|---|--|--|-----------------|--|--------------------|--|-----------------|--------------------|----------------|--|---------------------|--------------------|--------------------|--|---------------------|-----|--|----------|--|---|
| SELECT CODE SCOPE SYNC TEST                          |   |  |  |                 |  |                    |  |                 |                    |                |  |                     |                    |                    |  |                     |     |  |          |  |   |
|  |   | <b>NOTE</b>  |  |                 |  |                    |  |                 |                    |                |  |                     |                    |                    |  |                     |     |  |          |  |   |
| 70.1.  | Set (SELECT CODE) - S5, S6, and S7 to all zeros and press and release S8 SET switch.  | Do not use a coaxial cable for the next step. Use a scope X10 probe. Set scope to DC coupling. |  |                 |  |                    |  |                 |                    |                |  |                     |                    |                    |  |                     |     |  |          |  |   |
| 70.2.  | Connect oscilloscope probe to (SELECT SCOPE SYNC) - J6.   |  | Square wave of $9.0 \pm 2.0$ V p-p, period of $411 \pm 20$ milliseconds. |                 |  |                    |  |                 |                    |                |  |                     |                    |                    |  |                     |     |  |          |  |   |
| 71.  | <p>Connect scope (X10) probe to (RSC FIBER OPTIC INTERFACE) - SERIAL DATA J4 IN jack and set the following switches:</p> <table border="0" data-bbox="354 982 828 1591"> <thead> <tr> <th style="text-align: left;"><u>SWITCH</u></th> <th style="text-align: left;"><u>POSITION</u></th> </tr> </thead> <tbody> <tr> <td>(SELECT CODE) -</td> <td></td> </tr> <tr> <td>(TEST SET AUDIO) -</td> <td></td> </tr> <tr> <td>S9 MASTER RESET</td> <td>Press momentarily.</td> </tr> <tr> <td>(RETRANSMIT) -</td> <td></td> </tr> <tr> <td>S20 ENABLE /DISABLE</td> <td>Press momentarily.</td> </tr> <tr> <td>(TEST SET AUDIO) -</td> <td></td> </tr> <tr> <td>S24 TRANSMIT SELECT</td> <td>OFF</td> </tr> <tr> <td>S23 XMT SELECT (Hold for measurement, then release).</td> <td>IDLE OFF</td> </tr> </tbody> </table> | <u>SWITCH</u>  | <u>POSITION</u>  | (SELECT CODE) - |  | (TEST SET AUDIO) - |  | S9 MASTER RESET | Press momentarily. | (RETRANSMIT) - |  | S20 ENABLE /DISABLE | Press momentarily. | (TEST SET AUDIO) - |  | S24 TRANSMIT SELECT | OFF | S23 XMT SELECT (Hold for measurement, then release). | IDLE OFF | <p>CR21 ENABLED LED lights.</p> <p>SERIAL DATA IN J4 jack is one pulse wave of greater than or equal to 3.5 V amplitude, with a logic hi of <math>30 \pm 3</math> usec duration and a logic lo of <math>10 \pm 1</math> usec duration.</p> | <p>Normal indication: step 72.<br/>                     Incorrect indication: U19, U3, U2, U22, U20, U11 or associated circuitry.</p> |
| <u>SWITCH</u>  | <u>POSITION</u>   |  |  |                 |  |                    |  |                 |                    |                |  |                     |                    |                    |  |                     |     |  |          |  |   |
| (SELECT CODE) -                                      |   |  |  |                 |  |                    |  |                 |                    |                |  |                     |                    |                    |  |                     |     |  |          |  |   |
| (TEST SET AUDIO) -                                   |   |  |  |                 |  |                    |  |                 |                    |                |  |                     |                    |                    |  |                     |     |  |          |  |   |
| S9 MASTER RESET                                      | Press momentarily.  |  |  |                 |  |                    |  |                 |                    |                |  |                     |                    |                    |  |                     |     |  |          |  |   |
| (RETRANSMIT) -                                       |   |  |  |                 |  |                    |  |                 |                    |                |  |                     |                    |                    |  |                     |     |  |          |  |   |
| S20 ENABLE /DISABLE                                  | Press momentarily.  |  |  |                 |  |                    |  |                 |                    |                |  |                     |                    |                    |  |                     |     |  |          |  |   |
| (TEST SET AUDIO) -                                   |   |  |  |                 |  |                    |  |                 |                    |                |  |                     |                    |                    |  |                     |     |  |          |  |   |
| S24 TRANSMIT SELECT                                  | OFF   |  |  |                 |  |                    |  |                 |                    |                |  |                     |                    |                    |  |                     |     |  |          |  |   |
| S23 XMT SELECT (Hold for measurement, then release). | IDLE OFF  |  |  |                 |  |                    |  |                 |                    |                |  |                     |                    |                    |  |                     |     |  |          |  |   |

Table 5-14. RSC CCAs Fault Isolation Tests - Continued

| Step                     | Procedure  | Normal indication                  | Fault location  |                   |  |                        |                    |                    |  |                |    |                |   |                 |         |        |                    |                 |  |                      |             |                 |        |             |               |  |  |
|--------------------------|--|------------------------------------|---|-------------------|--|------------------------|--------------------|--------------------|--|----------------|----|----------------|---|-----------------|---------|--------|--------------------|-----------------|--|----------------------|-------------|-----------------|--------|-------------|---------------|--|--|
| SPEAKER AMP OUTPUT CHECK |  |                                    |   |                   |  |                        |                    |                    |  |                |    |                |   |                 |         |        |                    |                 |  |                      |             |                 |        |             |               |  |  |
| 72.                      | Set the following switches:<br><table border="0" style="width: 100%;"> <tr> <td style="text-align: center;"><u>SWITCH</u></td> <td style="text-align: center;"><u>POSITION</u></td> </tr> <tr> <td colspan="2">(SELECT CODE) -</td> </tr> <tr> <td>S9 MASTER RESET</td> <td>Press momentarily.</td> </tr> <tr> <td colspan="2">RSC Panel Assembly</td> </tr> <tr> <td>BATTERY switch</td> <td>ON</td> </tr> <tr> <td colspan="2">(POWER SOURCE)</td> </tr> <tr> <td>S13 BATTERY/SDU</td> <td>BATTERY</td> </tr> </table>   | <u>SWITCH</u>                      | <u>POSITION</u>   | (SELECT CODE) -   |  | S9 MASTER RESET        | Press momentarily. | RSC Panel Assembly |  | BATTERY switch | ON | (POWER SOURCE) |   | S13 BATTERY/SDU | BATTERY |        |                    |                 |  |                      |             |                 |        |             |               |  |  |
| <u>SWITCH</u>            | <u>POSITION</u>  |                                    |   |                   |  |                        |                    |                    |  |                |    |                |   |                 |         |        |                    |                 |  |                      |             |                 |        |             |               |  |  |
| (SELECT CODE) -          |  |                                    |   |                   |  |                        |                    |                    |  |                |    |                |   |                 |         |        |                    |                 |  |                      |             |                 |        |             |               |  |  |
| S9 MASTER RESET          | Press momentarily.   |                                    |   |                   |  |                        |                    |                    |  |                |    |                |   |                 |         |        |                    |                 |  |                      |             |                 |        |             |               |  |  |
| RSC Panel Assembly       |  |                                    |   |                   |  |                        |                    |                    |  |                |    |                |   |                 |         |        |                    |                 |  |                      |             |                 |        |             |               |  |  |
| BATTERY switch           | ON   |                                    |   |                   |  |                        |                    |                    |  |                |    |                |   |                 |         |        |                    |                 |  |                      |             |                 |        |             |               |  |  |
| (POWER SOURCE)           |  |                                    |   |                   |  |                        |                    |                    |  |                |    |                |   |                 |         |        |                    |                 |  |                      |             |                 |        |             |               |  |  |
| S13 BATTERY/SDU          | BATTERY  |                                    |   |                   |  |                        |                    |                    |  |                |    |                |   |                 |         |        |                    |                 |  |                      |             |                 |        |             |               |  |  |
| 73.                      | Adjust the audio generator for $400 \pm 20$ Hz and $6.0 \pm 1.0$ V p-p.  |                                    |   |                   |  |                        |                    |                    |  |                |    |                |   |                 |         |        |                    |                 |  |                      |             |                 |        |             |               |  |  |
| 74.                      | Set the following switches:<br><table border="0" style="width: 100%;"> <tr> <td style="text-align: center;"><u>SWITCH</u></td> <td style="text-align: center;"><u>POSITION</u></td> </tr> <tr> <td colspan="2">(TEST SET AUDIO)-</td> </tr> <tr> <td colspan="2">S24 TRANSMIT SELECT IC</td> </tr> <tr> <td colspan="2">(SELECT CODE) -</td> </tr> <tr> <td>S5 FCTN</td> <td>9</td> </tr> <tr> <td>S6 CONDITION</td> <td>0</td> </tr> <tr> <td>S7 CONDITION</td> <td>B</td> </tr> <tr> <td>S8 SET</td> <td>Press momentarily.</td> </tr> <tr> <td colspan="2">(SPEAKER) - S14</td> </tr> <tr> <td>OUTPUT LOAD /SPEAKER</td> <td>OUTPUT LOAD</td> </tr> <tr> <td>RSC SPKR VOLUME</td> <td>max CW</td> </tr> <tr> <td>RSC IC VOL.</td> <td>Ensure Max CW</td> </tr> </table> | <u>SWITCH</u>                      | <u>POSITION</u>   | (TEST SET AUDIO)- |  | S24 TRANSMIT SELECT IC |                    | (SELECT CODE) -    |  | S5 FCTN        | 9  | S6 CONDITION   | 0 | S7 CONDITION    | B       | S8 SET | Press momentarily. | (SPEAKER) - S14 |  | OUTPUT LOAD /SPEAKER | OUTPUT LOAD | RSC SPKR VOLUME | max CW | RSC IC VOL. | Ensure Max CW |  |  |
| <u>SWITCH</u>            | <u>POSITION</u>  |                                    |   |                   |  |                        |                    |                    |  |                |    |                |   |                 |         |        |                    |                 |  |                      |             |                 |        |             |               |  |  |
| (TEST SET AUDIO)-        |  |                                    |   |                   |  |                        |                    |                    |  |                |    |                |   |                 |         |        |                    |                 |  |                      |             |                 |        |             |               |  |  |
| S24 TRANSMIT SELECT IC   |  |                                    |   |                   |  |                        |                    |                    |  |                |    |                |   |                 |         |        |                    |                 |  |                      |             |                 |        |             |               |  |  |
| (SELECT CODE) -          |  |                                    |   |                   |  |                        |                    |                    |  |                |    |                |   |                 |         |        |                    |                 |  |                      |             |                 |        |             |               |  |  |
| S5 FCTN                  | 9  |                                    |   |                   |  |                        |                    |                    |  |                |    |                |   |                 |         |        |                    |                 |  |                      |             |                 |        |             |               |  |  |
| S6 CONDITION             | 0  |                                    |   |                   |  |                        |                    |                    |  |                |    |                |   |                 |         |        |                    |                 |  |                      |             |                 |        |             |               |  |  |
| S7 CONDITION             | B  |                                    |   |                   |  |                        |                    |                    |  |                |    |                |   |                 |         |        |                    |                 |  |                      |             |                 |        |             |               |  |  |
| S8 SET                   | Press momentarily.   |                                    |   |                   |  |                        |                    |                    |  |                |    |                |   |                 |         |        |                    |                 |  |                      |             |                 |        |             |               |  |  |
| (SPEAKER) - S14          |  |                                    |   |                   |  |                        |                    |                    |  |                |    |                |   |                 |         |        |                    |                 |  |                      |             |                 |        |             |               |  |  |
| OUTPUT LOAD /SPEAKER     | OUTPUT LOAD  |                                    |   |                   |  |                        |                    |                    |  |                |    |                |   |                 |         |        |                    |                 |  |                      |             |                 |        |             |               |  |  |
| RSC SPKR VOLUME          | max CW   |                                    |   |                   |  |                        |                    |                    |  |                |    |                |   |                 |         |        |                    |                 |  |                      |             |                 |        |             |               |  |  |
| RSC IC VOL.              | Ensure Max CW  |                                    |   |                   |  |                        |                    |                    |  |                |    |                |   |                 |         |        |                    |                 |  |                      |             |                 |        |             |               |  |  |
| 75.                      | Connect the audio generator to (TEST SET AUDIO) - J8 TRANSMIT jack. Using DVM, measure between (SPEAKER) - OUTPUT J2-A AND J3-B.   | Greater than or equal to 4.0 Vrms. | Normal indication: step 76.<br>Incorrect indication: Q4, Q14, U45, U46, R134 or associated circuitry. |                   |  |                        |                    |                    |  |                |    |                |   |                 |         |        |                    |                 |  |                      |             |                 |        |             |               |  |  |

Table 5-14. RSC CCAs Fault Isolation Tests - Continued

| Step                | Procedure   | Normal indication                                 | Fault location   |
|---------------------|---|---|--|
| SHUTDOWN PROCEDURES |   |   |  |
| 76.                 | Set RSC Panel Assembly BATTERY switch to the down position.   | (PRESENT OCTAL STATE) display goes from 37 to 00. | Normal indication: step 77.<br>Incorrect indication: RSC Front Panel BATTERY switch SW1 or wiring. |
| 77.                 | Set S1 ON switch to the down position, turn off all power supplies, disconnect cable W1 and all other cables from the test set. |   |  |

Table 5-15. RSC Test Set EPROM Select Codes

| Step      | Connection of test equipment | Point of test | Control settings and operation of equipment  | Performance standard |           |           |   |   |   |   |   |   |   |   |   |   |   |   |   |   |   |   |   |   |   |   |   |   |   |   |   |   |   |   |   |   |   |   |   |   |
|-----------|------------------------------|---------------|--|----------------------|-----------|-----------|---|---|---|---|---|---|---|---|---|---|---|---|---|---|---|---|---|---|---|---|---|---|---|---|---|---|---|---|---|---|---|---|---|---|
| 1.        |                              |               | <p style="text-align: center;"><b>NOTE</b></p> <p>Left hex digit is most significant digit. Right hex digit is least significant digit.</p> <p>Set each of the following switches: S5, S6, and S7 to the following numerals. Press S8 SET switch for each code and read the results on the digital interface assembly.</p> <p>RSC Test Set SELECT CODE</p> <table style="margin-left: auto; margin-right: auto;"> <thead> <tr> <th style="text-align: center;"><u>S5</u></th> <th style="text-align: center;"><u>S6</u></th> <th style="text-align: center;"><u>S7</u></th> </tr> </thead> <tbody> <tr> <td style="text-align: center;">0</td> <td style="text-align: center;">0</td> <td style="text-align: center;">4</td> </tr> <tr> <td style="text-align: center;">0</td> <td style="text-align: center;">0</td> <td style="text-align: center;">8</td> </tr> <tr> <td style="text-align: center;">0</td> <td style="text-align: center;">0</td> <td style="text-align: center;">C</td> </tr> <tr> <td style="text-align: center;">0</td> <td style="text-align: center;">1</td> <td style="text-align: center;">0</td> </tr> <tr> <td style="text-align: center;">0</td> <td style="text-align: center;">1</td> <td style="text-align: center;">4</td> </tr> <tr> <td style="text-align: center;">0</td> <td style="text-align: center;">1</td> <td style="text-align: center;">8</td> </tr> <tr> <td style="text-align: center;">0</td> <td style="text-align: center;">1</td> <td style="text-align: center;">C</td> </tr> <tr> <td style="text-align: center;">1</td> <td style="text-align: center;">0</td> <td style="text-align: center;">0</td> </tr> <tr> <td style="text-align: center;">1</td> <td style="text-align: center;">0</td> <td style="text-align: center;">4</td> </tr> <tr> <td style="text-align: center;">1</td> <td style="text-align: center;">0</td> <td style="text-align: center;">8</td> </tr> <tr> <td style="text-align: center;">1</td> <td style="text-align: center;">0</td> <td style="text-align: center;">C</td> </tr> </tbody> </table> | <u>S5</u>            | <u>S6</u> | <u>S7</u> | 0 | 0 | 4 | 0 | 0 | 8 | 0 | 0 | C | 0 | 1 | 0 | 0 | 1 | 4 | 0 | 1 | 8 | 0 | 1 | C | 1 | 0 | 0 | 1 | 0 | 4 | 1 | 0 | 8 | 1 | 0 | C | <p>LCD display on digital interface assembly is blank except for decimal points on HF, UHF-AM, and VHF-AM displays.</p> <p>All displays on.<br/>                     All digits, all displays: "0".<br/>                     All digits, all displays: "1".<br/>                     All digits, all displays: "2".<br/>                     All digits, all displays: "3".<br/>                     All digits, all displays: "4".<br/>                     All digits, all displays: "5".<br/>                     All digits, all displays: "6".<br/>                     All digits, all displays: "7".<br/>                     All digits, all displays: "8".</p> |
| <u>S5</u> | <u>S6</u>                    | <u>S7</u>     |  |                      |           |           |   |   |   |   |   |   |   |   |   |   |   |   |   |   |   |   |   |   |   |   |   |   |   |   |   |   |   |   |   |   |   |   |   |   |
| 0         | 0                            | 4             |  |                      |           |           |   |   |   |   |   |   |   |   |   |   |   |   |   |   |   |   |   |   |   |   |   |   |   |   |   |   |   |   |   |   |   |   |   |   |
| 0         | 0                            | 8             |  |                      |           |           |   |   |   |   |   |   |   |   |   |   |   |   |   |   |   |   |   |   |   |   |   |   |   |   |   |   |   |   |   |   |   |   |   |   |
| 0         | 0                            | C             |  |                      |           |           |   |   |   |   |   |   |   |   |   |   |   |   |   |   |   |   |   |   |   |   |   |   |   |   |   |   |   |   |   |   |   |   |   |   |
| 0         | 1                            | 0             |  |                      |           |           |   |   |   |   |   |   |   |   |   |   |   |   |   |   |   |   |   |   |   |   |   |   |   |   |   |   |   |   |   |   |   |   |   |   |
| 0         | 1                            | 4             |  |                      |           |           |   |   |   |   |   |   |   |   |   |   |   |   |   |   |   |   |   |   |   |   |   |   |   |   |   |   |   |   |   |   |   |   |   |   |
| 0         | 1                            | 8             |  |                      |           |           |   |   |   |   |   |   |   |   |   |   |   |   |   |   |   |   |   |   |   |   |   |   |   |   |   |   |   |   |   |   |   |   |   |   |
| 0         | 1                            | C             |  |                      |           |           |   |   |   |   |   |   |   |   |   |   |   |   |   |   |   |   |   |   |   |   |   |   |   |   |   |   |   |   |   |   |   |   |   |   |
| 1         | 0                            | 0             |  |                      |           |           |   |   |   |   |   |   |   |   |   |   |   |   |   |   |   |   |   |   |   |   |   |   |   |   |   |   |   |   |   |   |   |   |   |   |
| 1         | 0                            | 4             |  |                      |           |           |   |   |   |   |   |   |   |   |   |   |   |   |   |   |   |   |   |   |   |   |   |   |   |   |   |   |   |   |   |   |   |   |   |   |
| 1         | 0                            | 8             |  |                      |           |           |   |   |   |   |   |   |   |   |   |   |   |   |   |   |   |   |   |   |   |   |   |   |   |   |   |   |   |   |   |   |   |   |   |   |
| 1         | 0                            | C             |  |                      |           |           |   |   |   |   |   |   |   |   |   |   |   |   |   |   |   |   |   |   |   |   |   |   |   |   |   |   |   |   |   |   |   |   |   |   |

Table 5-15. RSC Test Set EPROM Select Codes - Continued

| Step        | Connection of test equipment | Point of test | Control settings and operation of equipment |                        |   | Performance standard                       |
|-------------|------------------------------|---------------|---|------------------------|---|--|
| 1.<br>cont. |                              |               | 1   | 1                      | 0 | All digits, all displays: "9".             |
|             |                              |               | 1   | 1                      | 4 | All digits, all displays: "F".             |
|             |                              |               | 1   | 1                      | 8 | 1st digit, all displays: "8".              |
|             |                              |               | 1   | 1                      | C | 2nd digit, all displays: "8".              |
|             |                              |               | 2   | 0                      | 0 | 3rd digit HF, UHF-AM, VHF-AM displays "8". |
|             |                              |               | 2   | 0                      | 4 | 4th digit HF, UHF-AM, VHF-AM displays "8". |
|             |                              |               | 2   | 0                      | 8 | 5th digit HF, UHF-AM, VHF-AM displays "8". |
|             |                              |               | 2   | 0                      | C | 6th digit HF, UHF-AM, VHF-AM displays "8". |
|             |                              |               | 2   | 1                      | 0 | HF displays all "8s".                      |
|             |                              |               | 2   | 1                      | 4 | UHF-AM display all "8s".                   |
|             |                              |               | 2   | 1                      | 8 | VHF-FM display both "8s".                  |
|             |                              |               | 2   | 1                      | C | VHF-AM display all "8s".                   |
|             |                              |               |   |                        |   | <u>DISPLAY</u>                             |
|             |                              |               |   | Refer to figure 5-14.1 |   |  |
|             |                              |               | 3   | 0                      | 0 | HF.....CALL                                |
|             |                              |               | 3   | 0                      | 1 | HF.....U                                   |
|             |                              |               | 3   | 0                      | 2 | HF.....L                                   |
|             |                              |               | 3   | 0                      | 3 | HF.....SQL                                 |
|             |                              |               | 3   | 0                      | 4 | HF.....PT                                  |
|             |                              |               | 3   | 0                      | 5 | UHF-AM...CALL                              |
|             |                              |               | 3   | 0                      | 6 | UHF-AM...PT                                |
|             |                              |               | 3   | 0                      | 7 | UHF-AM...DF                                |
|             |                              |               | 3   | 0                      | 8 | UHF-AM...GD                                |
|             |                              |               | 3   | 0                      | 9 | UHF-AM...SQL                               |
|             |                              |               | 3   | 0                      | A | VHF-FM...CALL                              |
|             |                              |               | 3   | 0                      | B | VHF-FM...PT                                |
|             |                              |               | 3   | 0                      | C | VHF-FM...MNL                               |
|             |                              |               | 3   | 0                      | D | STATUS FAULT                               |

Table 5-15. RSC Test Set EPROM Select Codes - Continued

| Step        | Connection of test equipment | Point of test | Control settings and operation of equipment  |   |   | Performance standard            |              |
|-------------|------------------------------|---------------|--|---|---|---------------------------------|--------------|
| 1.<br>cont. |                              |               | 3  | 0 | E | VHF-AM...CALL                   |              |
|             |                              |               | 3  | 0 | F | VHF-AM...PT                     |              |
|             |                              |               | 3  | 1 | 0 | VHF-AM...DF                     |              |
|             |                              |               | 3  | 1 | 1 | VHF-AM...GD                     |              |
|             |                              |               | 3  | 1 | 2 | VHF-AM...SQL                    |              |
|             |                              |               |  |   |   | FIRST                           |              |
|             |                              |               |  |   |   | DIGIT                           |              |
|             |                              |               |  |   |   | <u>DISPLAY</u>                  |              |
|             |                              |               |  |   |   | <u>SEGMENT</u>                  |              |
|             |                              |               |  | 6 | 0 | 7                               | VHF-FM.....A |
|             |                              |               |  | 6 | 0 | 8                               | VHF-FM.....B |
|             |                              |               |  | 6 | 0 | 9                               | VHF-FM.....C |
|             |                              |               |  | 6 | 0 | A                               | VHF-FM.....D |
|             |                              |               |  | 6 | 0 | B                               | VHF-FM.....E |
|             |                              |               |  | 6 | 0 | C                               | VHF-FM.....F |
|             |                              |               | 6  | 0 | D | VHF-FM.....G                    |              |
|             |                              |               |  |   |   | SECOND                          |              |
|             |                              |               |  |   |   | DIGIT                           |              |
|             |                              |               |  |   |   | <u>SEGMENT</u>                  |              |
| 2.          |                              |               | 6  | 0 | E | VHF-FM.....A                    |              |
|             |                              |               | 6  | 0 | F | VHF-FM.....B                    |              |
|             |                              |               | 6  | 1 | 0 | VHF-FM.....C                    |              |
|             |                              |               | 6  | 1 | 1 | VHF-FM.....D                    |              |
|             |                              |               | 6  | 1 | 2 | VHF-FM.....E                    |              |
|             |                              |               | 6  | 1 | 3 | VHF-FM.....F                    |              |
|             |                              |               | 6  | 1 | 4 | VHF-FM.....G                    |              |
| 2.          |                              |               | Press MASTER RESET S9 momentarily.           |   |   | Verify backlighting is off.     |              |
| 3.          |                              |               | Rotate RSC panel assembly R1 LIGHT fully CW. |   |   |                                 |              |
|             |                              |               | 8  | 0 | 1 | Verify backlighting is on.      |              |
|             |                              |               | 8  | 0 | 0 | Verify backlighting is off.     |              |
|             |                              |               | 0  | 0 | 0 | MASTER RESET S9 (no indication) |              |

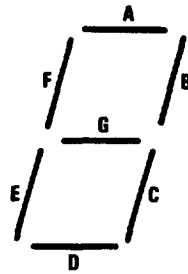

MX-01-118-074

Figure 5-14.1 Display Segment Identification

Table 5-16. RSC Wiring List

| Wire No. | Part No.        | Color      | From    | To    | Remarks                           |
|----------|-----------------|------------|---------|-------|-----------------------------------|
| 1        | M22759/11-26-91 | WHT/BRN    | SW3-3   | P1-16 | OPR 1 IC                          |
| 2        | M22759/11-26-9  | WHITE      | SW3-10  | P1-14 | OPR 1 VHF-FM                      |
| 3        | M22759/11-26-3  | ORANGE     | J1-B    | P1-5  | OPR 1 HANDSET/HELMET<br>AUDIO     |
| 4        | M22759/11-26-90 | WHT/BLK    | SW3-12  | P1-15 | OPR 1 VHF-AM                      |
| 5        | M22759/11-26-0  | BLACK      | SW3-COM | P1-3  | OPR 1 SWITCH COMMON               |
| 6        | M22759/11-26-92 | WHT/RED    | SW3-11  | P1-17 | OPR 1 UHF-AM                      |
| 7        | M22759/11-26-93 | WHT/ORN    | R2-3    | P1-18 | OPR 1 AUDIO OUT                   |
| 8        | M22759/11-26-96 | WHT/BLU    | SW3-2   | P1-24 | OPR 1 OFF                         |
| 10       | M22759/11-26-94 | WHT/YEL    | SW2-3   | P1-22 | MUTE                              |
| 11       | M22759/11-26-95 | WHT/GRN    | J1-C    | P1-23 | PTT 1#                            |
| 12       | M22759/11-26-7  | VIOLET     | R9-3    | P1-4  | SPEAKER AUDIO OUT                 |
| 13       | M22759/11-26-5  | GREEN      | SW3-7   | P1-7  | OPR 1 HF-SSB                      |
| 15       | M22759/11-26-4  | YELLOW     | R2-2    | P1-6  | OPR 1 AUDIO                       |
| 16       | M22759/11-26-97 | WHT/VIOLET | J1-D    | P1-25 | OPR 1 XMT AUDIO IN                |
| 18       | M22759/11-22-98 | WHT/GRAY   | SW1-2   | P1-26 | SWITCHED BATTERY POWER            |
| 19       | M22759/11-26-1  | BROWN      | J1-E    | P1-1  | DATA PORT PRESENT#                |
| 21       | M22759/11-26-6  | BLUE       | R9-4    | P1-9  | SPEAKER POWER OFF/ON#             |
| 22       | M22759/11-26-0  | BLACK      | R9-5    | P1-11 | SPEAKER POWER OFF/ON# RTN         |
| 23       | M22759/11-22-7  | VIOLET     | SW1-3   | P1-10 | BATTERY POWER                     |
| 24       | M22759/11-26-8  | GRAY       | R9-2    | P1-12 | SPEAKER AUDIO                     |
| 25       | M22759/11-26-96 | WHT/BLU    | R8-3    | P2-4  | OPR 2 AUDIO OUT                   |
| 26       | M22759/11-26-1  | BROWN      | R3-2    | P2-11 | IC AUDIO IN                       |
| 27       | M22759/11-26-95 | WHT/GRN    | R6-3    | P2-5  | VHF-AM AUDIO OUT                  |
| 28       | M22759/11-26-98 | WHT/GRY    | R8-2    | P2-2  | OPR 2 AUDIO                       |
| 29       | M22759/11-26-90 | WHT/BLK    | R5-2    | P2-10 | UHF-AM AUDIO IN                   |
| 30       | M22759/11-26-97 | WHT/VIO    | R5-3    | P2-3  | UHF-AM AUDIO OUT                  |
| 31       | M22759/11-26-0  | BLACK      | R7-1    | P2-18 | AUDIO SIG RTN                     |
| 32       | M22759/11-26-91 | WHT/BRN    | R7-2    | P2-9  | HF AUDIO IN                       |
| 33       | M22759/11-26-7  | VIOLET     | R7-3    | P2-21 | HF AUDIO OUT                      |
| 34       | M22759/11-26-0  | BLACK      | SW4-COM | P2-19 | OPR 2 SWITCH COMMON               |
| 35       | M22759/11-26-92 | WHT/RED    | R6-2    | P2-8  | VHF-AM AUDIO IN                   |
| 36       | M22759/11-26-9  | WHITE      | R4-3    | P2-1  | VHF-AM AUDIO OUT                  |
| 37       | M22759/11-26-97 | WHT/VIO    | SW4-7   | P2-26 | OPR 2 HF-SSB                      |
| 38       | M22759/11-26-93 | WHT/ORN    | R4-2    | P2-7  | VHF-FM AUDIO IN                   |
| 40       | M22759/11-26-3  | ORANGE     | SW4-12  | P2-13 | OPR 2 VHF-AM                      |
| 41       | M22759/11-26-94 | WHT/YEL    | R3-3    | P2-6  | IC AUDIO OUT                      |
| 42       | M22759/11-26-8  | GRAY       | J3-B    | P2-22 | OPR 2 RCV HANDSET/HELMET<br>AUDIO |
| 43       | M22759/11-26-5  | GREEN      | J3-C    | P2-15 | PTT 2#                            |



Table 5-16. RSC Wiring List - Continued

| Wire No. | Part No.        | Color   | From   | To    | Remarks                 |
|----------|-----------------|---------|--------|-------|-------------------------|
| 44       | M22759/11-26-4  | YELLOW  | SW4-2  | P2-14 | OPR 2 OFF               |
| 45       | M22759/11-26-6  | BLUE    | J3-D   | P2-16 | OPR 2 XMT AUDIO         |
| 47       | M22759/11-26-9  | WHITE   | SW4-10 | P2-24 | OPR 2 VHF-FM            |
| 48       | M22759/11-26-6  | BLUE    | SW4-3  | P2-12 | OPR 2 IC                |
| 49       | M22759/11-26-98 | WHT/GRY | SW4-11 | P2-25 | OPR 2 UHF-AM            |
| 50       | M22759/11-26-0  | BLACK   | SW2-2  | R9-5  | MUTE RTN#               |
| 51       | M22759/11-26-0  | BLACK   | R9-1   | P1-21 | SPEAKER VOL RTN         |
| 52       | M22759/11-26-0  | BLACK   | R8-1   | P2-23 | OPR 2 MASTER VOL RTN    |
| 53       | M22759/11-26-0  | BLACK   | R7-1   | R6-1  | AUDIO RTN               |
| 54       | M22759/11-26-0  | BLACK   | R6-1   | R5-1  | AUDIO RTN               |
| 55       | M22759/11-26-0  | BLACK   | R5-1   | R4-1  | AUDIO RTN               |
| 56       | M22759/11-26-0  | BLACK   | R4-1   | R3-1  | AUDIO RTN               |
| 57       | M22759/11-26-0  | BLACK   | P1-19  | R2-1  | OPR 1 MASTER VOL RTN    |
| 58       | M22759/11-26-5  | GREEN   | J3-C   | J4-C  | PTT 2#                  |
| 60       | M22759/11-26-8  | GRAY    | J3-B   | J4-B  | OPR 2 RCV AUDIO         |
| 61       | M22759/11-26-6  | BLUE    | J3-D   | J4-D  | OPR 2 XMT AUDIO         |
| 63       | M22759/11-26-3  | ORANGE  | J1-B   | J2-B  | OPR 1 RCV AUDIO         |
| 64       | M22759/11-26-95 | WHT/GRN | J1-C   | J2-C  | PTT 1#                  |
| 65       | M22759/11-26-97 | WHT/VIO | J1-D   | J2-D  | OPR 1 XMT AUDIO         |
| 68       | M22759/11-26-1  | BROWN   | J1-E   | J2-E  | DCT PRESET#             |
| 69       | M22759/11/26-6  | BLUE    | P4-H   | P3-2  | EL PNL AC POWER RTN     |
| 70       | M22759/11-26-4  | YELLOW  | P4-E   | P3-5  | EL PNL AC POWER         |
| 71       | M22759/11-24-0  | BLACK   | P4-F   | P3-NC | EL PNL SHIELD           |
| 72       | M22759/11-24-7  | VIOLET  | P4-A   | P3-3  | EL PNL DC POWER         |
| 73       | M22759/11-24-5  | GREEN   | R1-4   | P3-4  | EL PNL POWER CONTROL    |
| 74       | M22759/11-24-4  | YELLOW  | R1-5   | R1-3  | EL PNL DC POWER CONTROL |
| 75       | M22759/11-24-3  | ORANGE  | R1-2   | P4-C  | EL PNL POWER CONTROL    |
| 78       | M22759/11-26-0  | BLACK   | P4-B   | P3-1  | EL PNL DC RTN           |
| 79       | M22759/11-20-0  | BLACK   | P2-17  | E2    | GND                     |
| 80       | M22759/11-20-0  | BLACK   | P1-20  | E1    | GND                     |
| 81       | M22759/11-24-0  | BLACK   | J3-A   | E2    | GND                     |
| 82       | M22759/11-24-0  | BLACK   | J4-A   | E2    | GND                     |
| 83       | M22759/11-24-0  | BLACK   | J1-A   | E1    | GND                     |
| 84       | M22759/11-24-0  | BLACK   | J2-A   | E1    | GND                     |

## NOTES:

1. A NUMBER SIGN (#) FOLLOWING A SIGNAL NAME MEANS THE INVERTED (NOT) FORM OF THE SIGNAL.
2. UNLESS OTHERWISE SPECIFIED: VOLTAGES ARE DC.
3. REFER TO FO-14, RSC FRONT PANEL WIRING DIAGRAM.

5-10. RSC AUDIO INTERFACE CCA.

a. Bench Test Setup. The bench test setup of the RSC audio interface is illustrated in figure 5-13. The audio interface CCA is functionally checked during the RSC performance test.

CAUTION

Prior to handling electrostatic-sensitive electronic devices, personnel and equipment must be grounded to prevent static discharge damage to the device. Do not remove or install subassembly in test fixture with power applied or damage to equipment may result.

NOTE

Subassemblies shipped in nonapproved containers are subject to multiple failures due to mishandling.

b. Component Performance Test Table. The component performance tests for the audio interface CCA are contained in table 5-14. This table is keyed to fault isolation procedures in table 5-15.

c. Mechanical Assemblies. NOT APPLICABLE

d. Cleaning and Lubrication.

CAUTION

Prior to handling electrostatic-sensitive electronic devices, personnel and equipment must be grounded to prevent static discharge damage to the device.

NOTE

Prefix component reference designators of the audio interface CCA with 5A2A2 or 6A2A2.

Clean the audio interface CCA in accordance with TO 00-25-234.

e. Repair and Replacement. Repair of the audio interface CCA consists of the removal of malfunctioning components and their replacement with serviceable components. Refer to IPB figure 7-19 for items that are SMR coded for repair at depot level. Upon receipt of an RSC audio interface CCA for repair, perform the following procedures as required:

**CAUTION**

Microcircuits U1, U5, U8 through U13, U16 through U22, and U32 through U40 are susceptible to electrostatic discharge damage. Prior to handling electrostatic-sensitive electronic devices, personnel and equipment must be grounded to prevent static discharge damage to the device.

- (1) Visually inspect wiring and CCAs for damage to components or traces from heat, deterioration, moisture, or deposits from oxidation or corrosion.
- (2) Check for broken wires, bent pins, frayed insulation, and poor soldering connections.
- (3) Check printed wiring board for cracks or delamination.
- (4) Replace defective components. Refer to figures 5-15 and 7-19 for component location and orientation. Maximum allowable component height of modified screw (1, figure 7-19) above printed wiring board (90) is 0.128 inch. Maximum allowable component height of modified screw (1) below printed wiring board (90) is 0.774 inch.
- (5) Perform all soldering and other electronic maintenance in accordance with TO 00-25-234 per MIL-STD-454, Requirement 5. Use solder Type SN60WRMAP2 per QQ-S-571.
- (6) Except for areas indicated on figure 5-15, cover both sides of audio interface CCA with conformal coating per M-I-46058, Type UR.
- (7) Maximum component height of resistor R212 above printed wiring board is 0.375 inch.

f. Reassembly and Testing of Subassemblies and Assemblies. Refer to the above paragraph, Repair and Replacement, for special reassembly instructions of the audio interface CCA.

g. Testing. Perform the instructions contained in table 5-14, RSC CCAs Component Performance Tests, to ensure the serviceable condition of the subassembly.

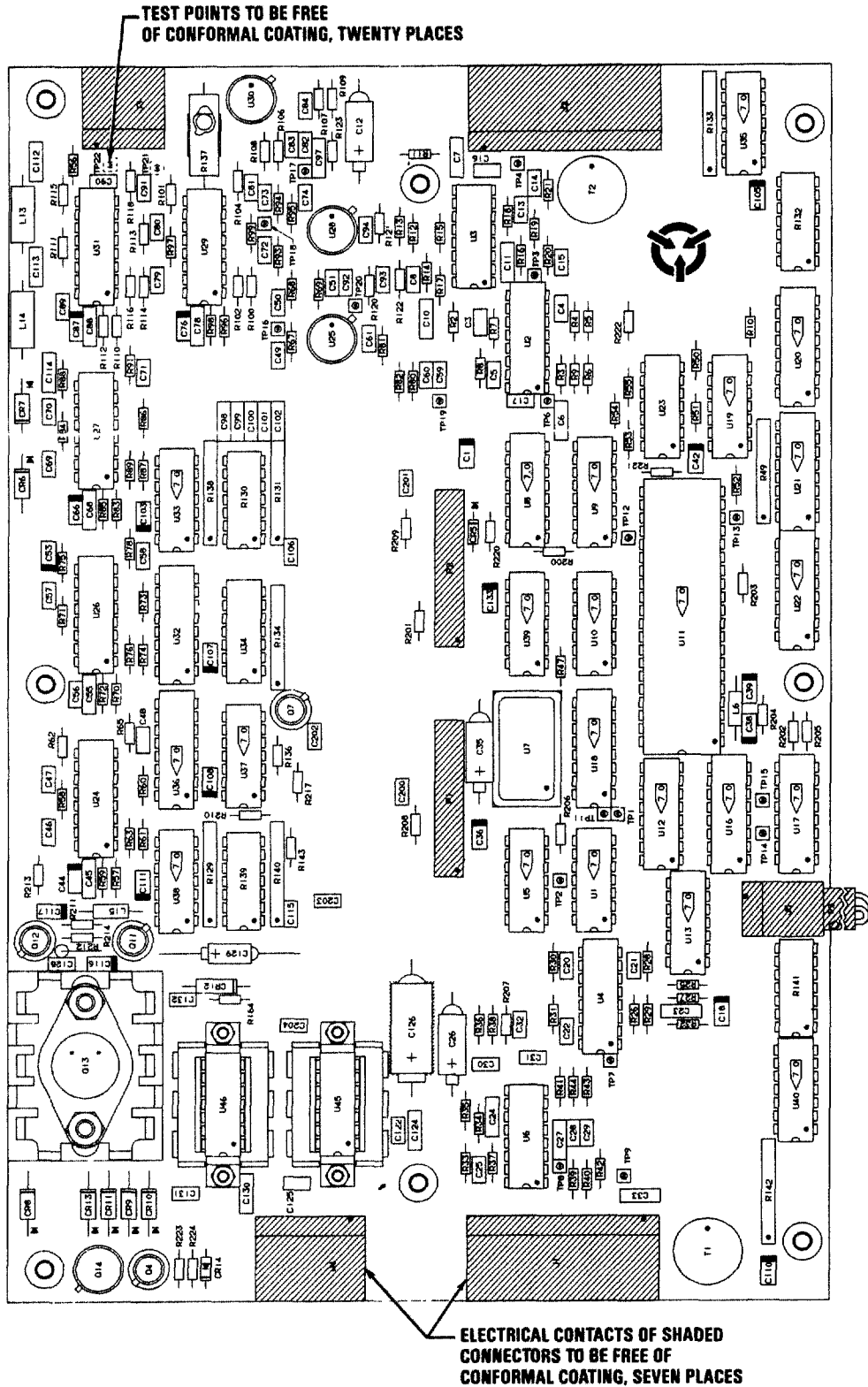

MX 61-119-032-1  
REF MX DWG NO. 813233 REV M

Figure 5-15. RSC Audio Interface 5A2A2 or 6A2A2 Component Location (Sheet 1 of 2)

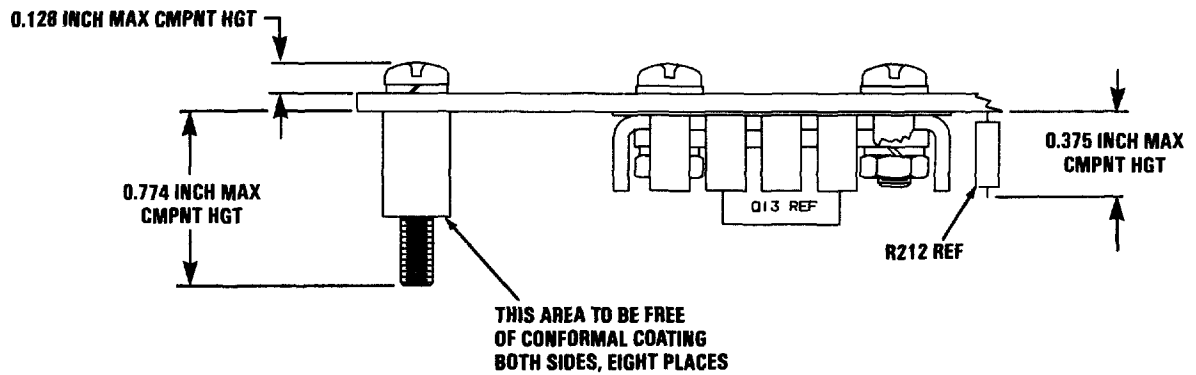

MX-61 118-032-2  
REF MX DWG NO 813233 REV M

Figure 5-15. RSC Audio Interface 5A2A2 or 6A2A2 Component Location  
(Sheet 2 of 2)

5-11. RSC DIGITAL INTERFACE CCA.

a. Bench Test Setup. The bench test setup of the digital interface is illustrated in figure 5-13. The digital interface is functionally checked during the RSC performance test.

CAUTION

Prior to handling electrostatic-sensitive electronic devices, personnel and equipment must be grounded to prevent static discharge damage to the device. Do not remove or install subassembly in test fixture with power applied or damage to equipment may result.

NOTE

Subassemblies shipped in nonapproved containers may contain multiple failures due to mishandling.

b. Component Performance Test Table. The component performance tests for the digital interface CCA are contained in table 5-14. This table is keyed to fault isolation procedures in table 5-15.

c. Mechanical Assemblies. NOT APPLICABLE

d. Cleaning and Lubrication.

CAUTION

Prior to handling electrostatic-sensitive electronic devices, personnel and equipment must be grounded to prevent static discharge damage to the device.

NOTE

Prefix component reference designators of the digital interface CCA with 5A2A1 or 6A2A1.

Clean the digital interface in accordance with TO 00-25-234.

e. Repair and Replacement. Repair of the digital interface consists of the removal of malfunctioning components and their replacement with serviceable components. Refer to IPB figure 7-20 for items that are SMR coded for repair at depot level. Upon receipt of a digital interface for repair at depot level, perform the following procedures:

CAUTION

Microcircuits U1 through U7, U9 through U22, U27 through U45, and transistors Q2 and Q3 are susceptible to electrostatic discharge damage. Prior to handling electrostatic-sensitive electronic devices, personnel and equipment must be grounded to prevent static discharge damage to the device.

- (1) Visually inspect CCA for damage to components or traces from heat, deterioration, moisture, or deposits from oxidation or corrosion.
- (2) Check for broken wires, bent pins, frayed insulation, and poor soldering connections.
- (3) Check printed wiring board for cracks or delamination.
- (4) Replace defective components. Refer to figures 5-16 and 7-20 for component location and orientation.
- (5) Perform all soldering and other electronic maintenance in accordance with TO 00-25-234 per MIL-STD-454, Requirement 5. Use solder Type SN60WRMAP2 per QQ-S-571.
- (6) Soldering of solder fillets on top side of board is not required for integrated circuits U24 and U26 (59, figure 7-20).
- (7) Cut the leads of digital microcircuits U1 and U2 (3, figure 7-20) flush with printed wiring board (75).
- (8) Secure capacitors (29 and 30) to printed wiring board (75) using adhesives per MIL-A-46106, Type I, color translucent.
- (9) Except for indicated areas in figure 5-16, cover both sides of the CCA with conformal coating per MIL-I-46058, Type UR.

f. Reassembly and Testing of Subassemblies and Assemblies. Refer to the above paragraph, Repair and Replacement, for special reassembly instructions of the digital interface.

g. Testing. Perform the instructions contained in table 5-14, RSC CCAs Component Performance Tests, to ensure the serviceable condition of the subassembly.

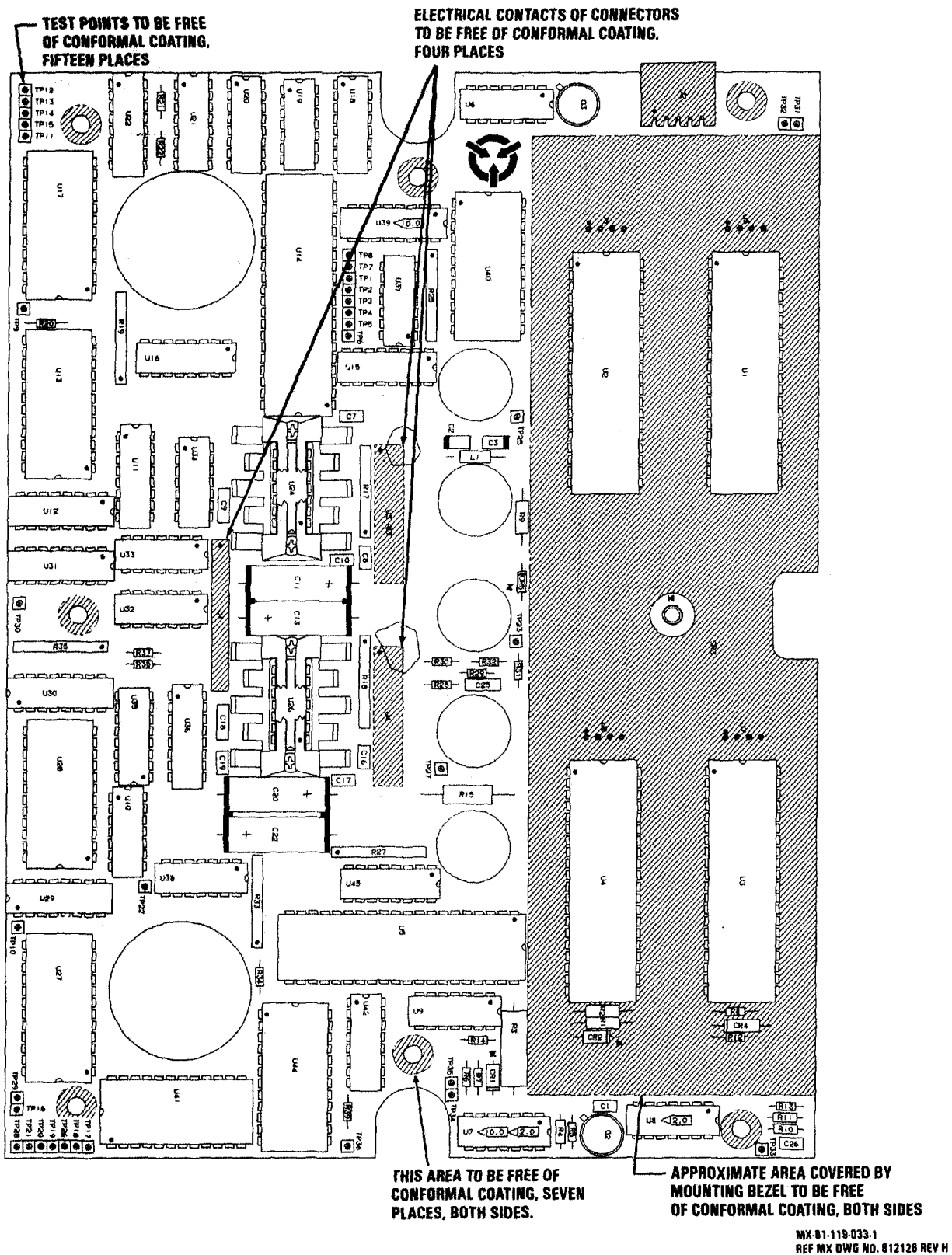
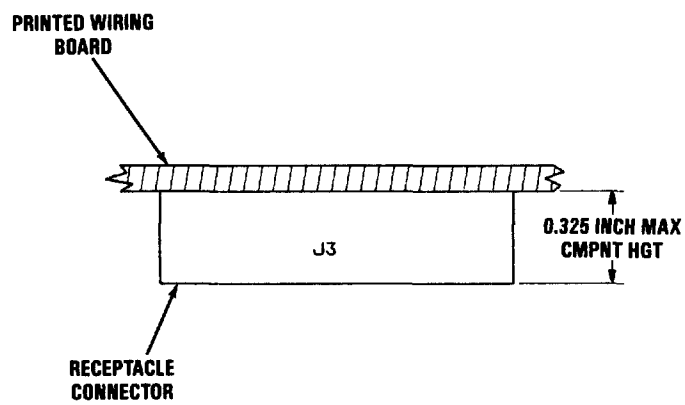

Figure 5-16. RSC Digital Interface CCA 5A2A1 or 6A2A1 Component Location (Sheet 1 of 2)





MX-81-118-033-2  
REF MX DWG NO. 812128 REV H

Figure 5-16. RSC Digital Interface CCA 5A2A1 or 6A2A1 Component Location  
(Sheet 2 of 2)

5-12. RSC REGULATOR CCA.

a. Bench Test Setup. The bench test setup of the regulator is illustrated in figure 5-17.

NOTE

Subassemblies shipped in nonapproved containers may be subject to multiple failures due to mishandling.

b. Component Performance Test Table. The component performance tests for the regulator are contained in table 5-17. This table is keyed to fault isolation procedures in table 5-18.

c. Mechanical Assemblies. NOT APPLICABLE

d. Cleaning and Lubrication.

NOTE

Prefix component reference designators of the regulator with 5A1A1A or 6A1A1.

Clean regulator in accordance with TO 00-25-234.

e. Repair and Replacement. Repair of the regulator consists of the removal of malfunctioning components and their replacement with serviceable components. Refer to IPB figure 7-23 for items that are SMR coded for repair at depot level. Upon receipt of a regulator for repair at depot level, perform the following procedures:

- (1) Visually inspect regulator for damage to components or traces from heat, deterioration, moisture, or deposits from oxidation or corrosion.
- (2) Check for broken wires, bent pins, frayed insulation, and poor soldering connections.
- (3) Check printed wiring board for cracks or delamination.
- (4) Replace defective components. Refer to figures 5-18 and 7-23 for component location and orientation.
- (5) Perform all soldering and other electronic maintenance in accordance with TO 00-25-234 per MIL-STD-454, Requirement 5. Use solder Type SN60WRMAP2 per QQ-S-571.
- (6) Except for indicated areas in figure 5-18, cover both sides of the regulator with conformal coating per MIL-I-46058, Type UR.

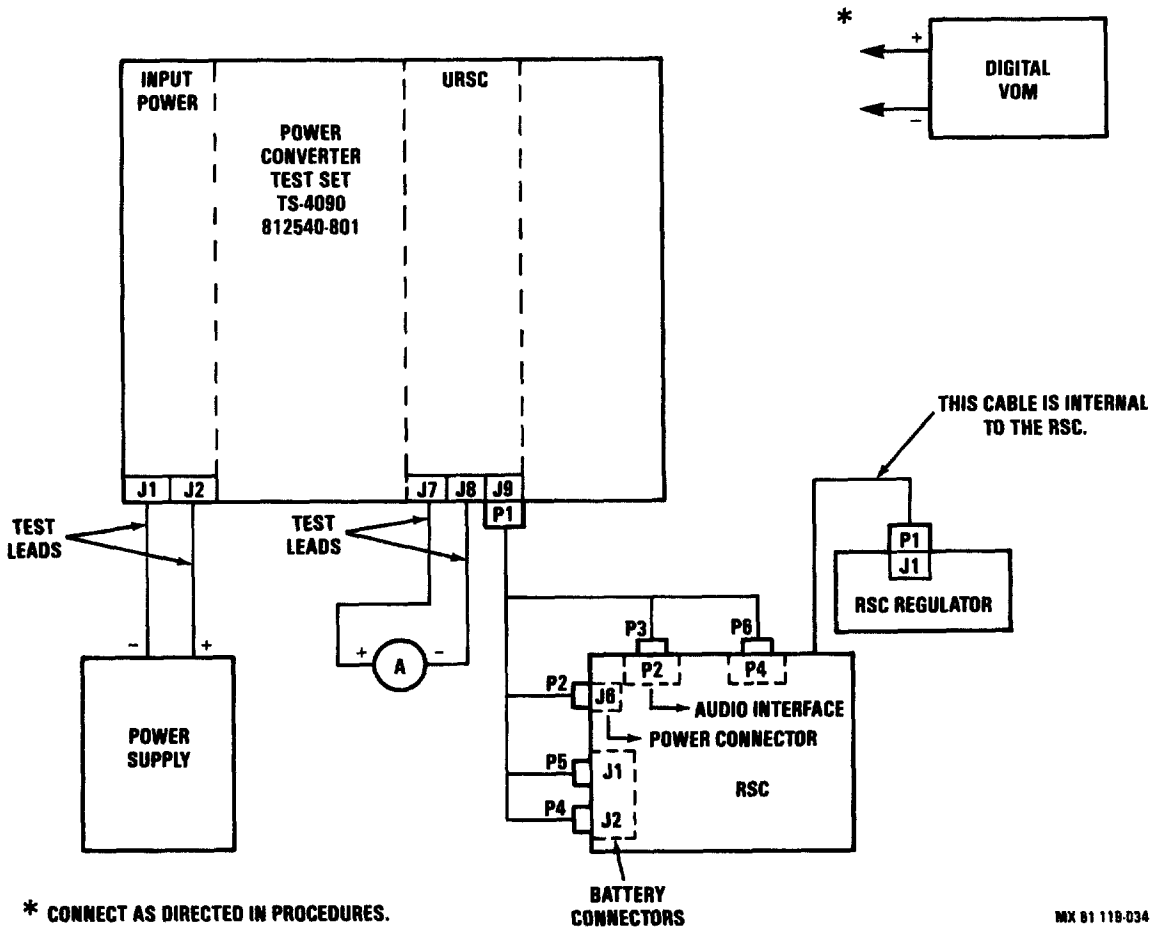

Figure 5-17. RSC Regulator CCA 5A1A1 or 6A1A1 Component Location

Table 5-17. RSC Regulator CGA Component Performance Tests

| Step               | Connection of test equipment                    | Point of test       | Control settings and operation of equipment  | Performance standard         |                 |                   |      |                   |     |                   |     |              |  |          |      |                    |    |  |
|--------------------|---|---------------------|--|------------------------------|-----------------|-------------------|------|-------------------|-----|-------------------|-----|--------------|--|----------|------|--------------------|----|--|
| 1.                 |   |                     | Set power supply current to maximum for all tests.   |                              |                 |                   |      |                   |     |                   |     |              |  |          |      |                    |    |  |
| 2.                 | Connect test equipment as shown in figure 5-17. |                     |  |                              |                 |                   |      |                   |     |                   |     |              |  |          |      |                    |    |  |
| 3.                 |   |                     | Set the following test set switches.<br><br><table border="0" style="width: 100%;"> <thead> <tr> <th style="text-align: left;"><u>Switch</u></th> <th style="text-align: left;"><u>Position</u></th> </tr> </thead> <tbody> <tr> <td>S9 BATTERY SELECT</td> <td>BT1A</td> </tr> <tr> <td>S10 SHUNTED 17VDC</td> <td>MIN</td> </tr> <tr> <td>S11 SPEAKER 17VDC</td> <td>MIN</td> </tr> <tr> <td>S12 BAT PLRT</td> <td></td> </tr> <tr> <td>RVS NORM</td> <td>NORM</td> </tr> <tr> <td>S13 SPEAKER ON OFF</td> <td>ON</td> </tr> </tbody> </table><br>REGULATOR TEST | <u>Switch</u>                | <u>Position</u> | S9 BATTERY SELECT | BT1A | S10 SHUNTED 17VDC | MIN | S11 SPEAKER 17VDC | MIN | S12 BAT PLRT |  | RVS NORM | NORM | S13 SPEAKER ON OFF | ON |  |
| <u>Switch</u>      | <u>Position</u>                                 |                     |  |                              |                 |                   |      |                   |     |                   |     |              |  |          |      |                    |    |  |
| S9 BATTERY SELECT  | BT1A  |                     |  |                              |                 |                   |      |                   |     |                   |     |              |  |          |      |                    |    |  |
| S10 SHUNTED 17VDC  | MIN   |                     |  |                              |                 |                   |      |                   |     |                   |     |              |  |          |      |                    |    |  |
| S11 SPEAKER 17VDC  | MIN   |                     |  |                              |                 |                   |      |                   |     |                   |     |              |  |          |      |                    |    |  |
| S12 BAT PLRT       |   |                     |  |                              |                 |                   |      |                   |     |                   |     |              |  |          |      |                    |    |  |
| RVS NORM           | NORM  |                     |  |                              |                 |                   |      |                   |     |                   |     |              |  |          |      |                    |    |  |
| S13 SPEAKER ON OFF | ON  |                     |  |                              |                 |                   |      |                   |     |                   |     |              |  |          |      |                    |    |  |
| 4.                 | Ammeter   |                     | Set power supply to 17 +/- 0.5 VDC and test set CB1 to ON.   | Ammeter reads 0.85A +/- 0.2. |                 |                   |      |                   |     |                   |     |              |  |          |      |                    |    |  |
| 5.                 | Ammeter   |                     | Set SHUNTED 17VDC S10 to MAX.  | Ammeter reads 0.95A +/- 0.2. |                 |                   |      |                   |     |                   |     |              |  |          |      |                    |    |  |
| 6.                 | Digital VOM                                     | TP19(+) to TP22(-). |  | 16.0 +/- 2 VDC.              |                 |                   |      |                   |     |                   |     |              |  |          |      |                    |    |  |
| 7.                 | Ammeter   |                     | Set SPEAKER 17VDC S11 to MAX.  | 0.95A +/- 0.2.               |                 |                   |      |                   |     |                   |     |              |  |          |      |                    |    |  |

Table 5-17. RSC Regulator CCA Component Performance Tests - Continued

| Step   | Connection of test equipment | Point of test       | Control settings and operation of equipment   | Performance standard    |                 |                   |      |                   |     |                   |     |                  |      |             |     |  |
|--|------------------------------|---------------------|---|-------------------------|-----------------|-------------------|------|-------------------|-----|-------------------|-----|------------------|------|-------------|-----|--|
| 8.   | Digital VOM                  | TP20(+) to TP22(-). |   | 16.0 +/- 2 VDC.         |                 |                   |      |                   |     |                   |     |                  |      |             |     |  |
| <div style="border: 1px solid black; padding: 2px; display: inline-block; margin-bottom: 5px;"><b>CAUTION</b></div> <p>Ensure S12 is held in BAT PLRT RVS position only momentarily or damage to equipment may result.</p> |                              |                     |   |                         |                 |                   |      |                   |     |                   |     |                  |      |             |     |  |
| 9.   | Ammeter                      |                     | Momentarily set BAT PLRT RVS S12 to BAT PLRT RVS.   | 0.95A +/- 0.2.          |                 |                   |      |                   |     |                   |     |                  |      |             |     |  |
| 10.  | Digital VOM                  | TP21(+) to TP22(-). |   | 16.02 +/- VDC.          |                 |                   |      |                   |     |                   |     |                  |      |             |     |  |
| 11.  |                              |                     | Return the test set switches to settings listed in step 3.  |                         |                 |                   |      |                   |     |                   |     |                  |      |             |     |  |
| 12.  |                              |                     | Repeat steps 5 to 10 with BATTERY SELECT S9 to the following positions.   | Same as previous steps. |                 |                   |      |                   |     |                   |     |                  |      |             |     |  |
|  |                              |                     | BT1B<br>BT2A<br>BT2B  |                         |                 |                   |      |                   |     |                   |     |                  |      |             |     |  |
| 13.  | Digital VOM                  | TP23(+) TP24(-)     | Set the following test set switches.  | 75 +/- 7.5 RMS          |                 |                   |      |                   |     |                   |     |                  |      |             |     |  |
|  |                              |                     | <table style="width: 100%; border-collapse: collapse;"> <thead> <tr> <th style="text-align: left; border-bottom: 1px solid black;"><u>SWITCH</u></th> <th style="text-align: left; border-bottom: 1px solid black;"><u>POSITION</u></th> </tr> </thead> <tbody> <tr> <td>BATTERY SELECT S9</td> <td>BT1A</td> </tr> <tr> <td>SHUNTED 17VDC S10</td> <td>MIN</td> </tr> <tr> <td>SPEAKER 17VDC S11</td> <td>MIN</td> </tr> <tr> <td>BAT PLRT RVS S12</td> <td>NORM</td> </tr> <tr> <td>SPEAKER S13</td> <td>OFF</td> </tr> </tbody> </table> | <u>SWITCH</u>           | <u>POSITION</u> | BATTERY SELECT S9 | BT1A | SHUNTED 17VDC S10 | MIN | SPEAKER 17VDC S11 | MIN | BAT PLRT RVS S12 | NORM | SPEAKER S13 | OFF |  |
| <u>SWITCH</u>  | <u>POSITION</u>              |                     |   |                         |                 |                   |      |                   |     |                   |     |                  |      |             |     |  |
| BATTERY SELECT S9  | BT1A                         |                     |   |                         |                 |                   |      |                   |     |                   |     |                  |      |             |     |  |
| SHUNTED 17VDC S10  | MIN                          |                     |   |                         |                 |                   |      |                   |     |                   |     |                  |      |             |     |  |
| SPEAKER 17VDC S11  | MIN                          |                     |   |                         |                 |                   |      |                   |     |                   |     |                  |      |             |     |  |
| BAT PLRT RVS S12   | NORM                         |                     |   |                         |                 |                   |      |                   |     |                   |     |                  |      |             |     |  |
| SPEAKER S13  | OFF                          |                     |   |                         |                 |                   |      |                   |     |                   |     |                  |      |             |     |  |
| 14.  |                              |                     | Normalize test equipment.   |                         |                 |                   |      |                   |     |                   |     |                  |      |             |     |  |

Table 5-18. RSC Regulator CCA Fault Isolation Tests

| Step              | Procedure   | Normal indication            | Fault location                     |                   |      |                   |     |                   |     |              |  |          |      |                |    |     |  |  |  |
|-------------------|---|------------------------------|------------------------------------|-------------------|------|-------------------|-----|-------------------|-----|--------------|--|----------|------|----------------|----|-----|--|--|--|
| 1.                | Set power supply current to maximum for all tests.  |                              |                                    |                   |      |                   |     |                   |     |              |  |          |      |                |    |     |  |  |  |
| 2.                | Connect test equipment as shown in figure 5-17.   |                              |                                    |                   |      |                   |     |                   |     |              |  |          |      |                |    |     |  |  |  |
| 3.                | Set the following test set switches.  |                              |                                    |                   |      |                   |     |                   |     |              |  |          |      |                |    |     |  |  |  |
|                   | <table border="0"> <tr> <td><u>Switch</u></td> <td><u>Position</u></td> </tr> <tr> <td>S9 BATTERY SELECT</td> <td>BT1A</td> </tr> <tr> <td>S10 SHUNTED 17VDC</td> <td>MIN</td> </tr> <tr> <td>S11 SPEAKER 17VDC</td> <td>MIN</td> </tr> <tr> <td>S12 BAT PLRT</td> <td></td> </tr> <tr> <td>RVS NORM</td> <td>NORM</td> </tr> <tr> <td>S13 SPEAKER ON</td> <td>ON</td> </tr> <tr> <td>OFF</td> <td></td> </tr> </table> | <u>Switch</u>                | <u>Position</u>                    | S9 BATTERY SELECT | BT1A | S10 SHUNTED 17VDC | MIN | S11 SPEAKER 17VDC | MIN | S12 BAT PLRT |  | RVS NORM | NORM | S13 SPEAKER ON | ON | OFF |  |  |  |
| <u>Switch</u>     | <u>Position</u>   |                              |                                    |                   |      |                   |     |                   |     |              |  |          |      |                |    |     |  |  |  |
| S9 BATTERY SELECT | BT1A  |                              |                                    |                   |      |                   |     |                   |     |              |  |          |      |                |    |     |  |  |  |
| S10 SHUNTED 17VDC | MIN   |                              |                                    |                   |      |                   |     |                   |     |              |  |          |      |                |    |     |  |  |  |
| S11 SPEAKER 17VDC | MIN   |                              |                                    |                   |      |                   |     |                   |     |              |  |          |      |                |    |     |  |  |  |
| S12 BAT PLRT      |   |                              |                                    |                   |      |                   |     |                   |     |              |  |          |      |                |    |     |  |  |  |
| RVS NORM          | NORM  |                              |                                    |                   |      |                   |     |                   |     |              |  |          |      |                |    |     |  |  |  |
| S13 SPEAKER ON    | ON  |                              |                                    |                   |      |                   |     |                   |     |              |  |          |      |                |    |     |  |  |  |
| OFF               |   |                              |                                    |                   |      |                   |     |                   |     |              |  |          |      |                |    |     |  |  |  |
|                   | REGULATOR TEST  |                              |                                    |                   |      |                   |     |                   |     |              |  |          |      |                |    |     |  |  |  |
| 4.                | Set power supply to 17 +/- 0.5 VDC and test set CB1 to ON.  | Ammeter reads 0.85A +/-0.2.  |                                    |                   |      |                   |     |                   |     |              |  |          |      |                |    |     |  |  |  |
| 5.                | Set SHUNTED 17VDC S10 to MAX.   | Ammeter reads 0.95A +/-0.2.  |                                    |                   |      |                   |     |                   |     |              |  |          |      |                |    |     |  |  |  |
| 6.                | Connect digital VOM between TP19(+) and TP22(-).  | 16.0 +/- 2 VDC.              |                                    |                   |      |                   |     |                   |     |              |  |          |      |                |    |     |  |  |  |
| 7.                | Set SPEAKER 17VDC S11 to MAX.   | Ammeter reads 0.95A +/- 0.2. |                                    |                   |      |                   |     |                   |     |              |  |          |      |                |    |     |  |  |  |
| 8.                | Connect digital VOM between TP20(+) and TP22(-).  | 16.0 +/- 2 VDC.              | Q1 or Q1 and associated circuitry. |                   |      |                   |     |                   |     |              |  |          |      |                |    |     |  |  |  |
|                   | <div style="border: 1px solid black; padding: 2px; display: inline-block;"><b>CAUTION</b></div>   |                              |                                    |                   |      |                   |     |                   |     |              |  |          |      |                |    |     |  |  |  |
|                   | Ensure S12 is held in BAT PLRT RVS position only momentarily or damage to equipment may result.   |                              |                                    |                   |      |                   |     |                   |     |              |  |          |      |                |    |     |  |  |  |
| 9.                | Momentarily set BAT PLRT RVS S12 to BAT PLRT RVS and read ammeter.  | 0.95A +/- 0.2.               |                                    |                   |      |                   |     |                   |     |              |  |          |      |                |    |     |  |  |  |
| 10.               | Connect digital VOM between TP21(+) and TP22(-).  | 16.0 +/- 2 VDC               | Diodes CR1 through CR4.            |                   |      |                   |     |                   |     |              |  |          |      |                |    |     |  |  |  |
| 11.               | Return the test set switches to settings listed in step 3.  |                              |                                    |                   |      |                   |     |                   |     |              |  |          |      |                |    |     |  |  |  |

Table 18. RSC Regulator CCA Fault Isolation Tests - Continued

| Step              | Procedure   | Normal indication       | Fault location          |                   |      |                   |     |                   |     |                  |      |             |     |                |                             |
|-------------------|---|-------------------------|-------------------------|-------------------|------|-------------------|-----|-------------------|-----|------------------|------|-------------|-----|----------------|-----------------------------|
| 12.               | Repeat steps 5 to 10 with BATTERY SELECT S9 to the following positions.<br>BT1B<br>BT2A<br>BT2B   | Same as previous steps. | Diodes CR1 through CR4. |                   |      |                   |     |                   |     |                  |      |             |     |                |                             |
| 13.               | Set the following test set switches and take reading with digital VOM set to VAC.<br><table border="0" style="width: 100%; border-collapse: collapse;"> <thead> <tr> <th style="text-align: left; border-bottom: 1px solid black;"><u>SWITCH</u></th> <th style="text-align: left; border-bottom: 1px solid black;"><u>POSITION</u></th> </tr> </thead> <tbody> <tr> <td>BATTERY SELECT S9</td> <td>BT1A</td> </tr> <tr> <td>SHUNTED 17VDC S10</td> <td>MIN</td> </tr> <tr> <td>SPEAKER 17VDC S11</td> <td>MIN</td> </tr> <tr> <td>BAT PLRT RVS S12</td> <td>NORM</td> </tr> <tr> <td>SPEAKER S13</td> <td>OFF</td> </tr> </tbody> </table> | <u>SWITCH</u>           | <u>POSITION</u>         | BATTERY SELECT S9 | BT1A | SHUNTED 17VDC S10 | MIN | SPEAKER 17VDC S11 | MIN | BAT PLRT RVS S12 | NORM | SPEAKER S13 | OFF | 75 +/- 7.5 RMS | Q3 or associated circuitry. |
| <u>SWITCH</u>     | <u>POSITION</u>   |                         |                         |                   |      |                   |     |                   |     |                  |      |             |     |                |                             |
| BATTERY SELECT S9 | BT1A  |                         |                         |                   |      |                   |     |                   |     |                  |      |             |     |                |                             |
| SHUNTED 17VDC S10 | MIN   |                         |                         |                   |      |                   |     |                   |     |                  |      |             |     |                |                             |
| SPEAKER 17VDC S11 | MIN   |                         |                         |                   |      |                   |     |                   |     |                  |      |             |     |                |                             |
| BAT PLRT RVS S12  | NORM  |                         |                         |                   |      |                   |     |                   |     |                  |      |             |     |                |                             |
| SPEAKER S13       | OFF   |                         |                         |                   |      |                   |     |                   |     |                  |      |             |     |                |                             |
| 14.               | Normalize test equipment.   |                         |                         |                   |      |                   |     |                   |     |                  |      |             |     |                |                             |

**T.O. 31R2-2GRC206-12**

- f. Reassembly and Testing of Subassemblies and Assemblies. Refer to the above paragraph, Repair and Replacement, for special instructions of the regulator.
- g. Testing. Perform the instructions contained in table 5-17, RSC Regulator CCA Component Performance Tests, to ensure the serviceable condition of the subassembly.



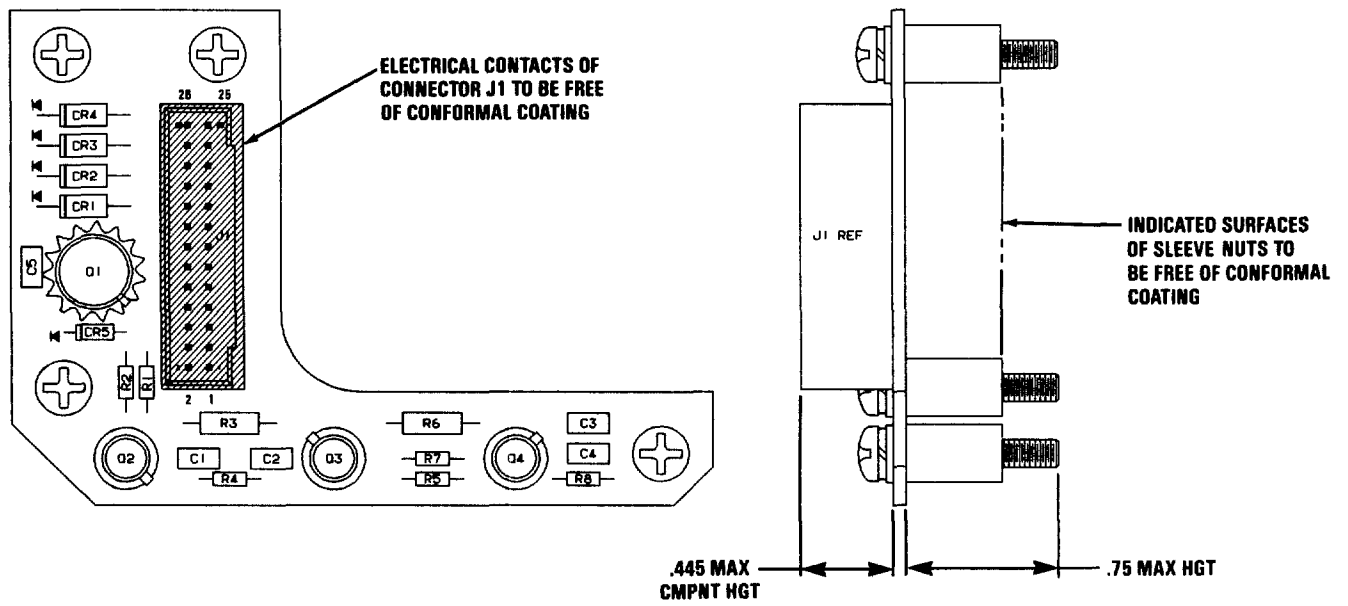

MX 81-119 035  
REF MX DWG NO 812866 REV E

Figure 5-18. RSC Regulator CCA 5A1A1 or 6A1A1 Component Location

5-13. FM BITE/AUDIO INTERFACE ASSEMBLY.

a. Bench Test Setup. The bench test setup of the FM/BITE audio interface is illustrated in figure 5-19.

CAUTION

Prior to handling electrostatic-sensitive electronic devices, personnel and equipment must be grounded to prevent static discharge damage to the device. Do not remove or install subassembly in test fixture with power applied or damage to equipment may result.

NOTE

Subassemblies shipped in nonapproved containers may be subject to multiple failures due to mishandling.

b. Component Performance Test Table. The component performance tests for the FM BITE/audio interface is contained in table 5-19. This table is keyed to fault isolation procedures in table 5-20.

c. Mechanical Assemblies. NOT APPLICABLE

d. Cleaning and Lubrication.

CAUTION

Prior to handling electrostatic-sensitive electronic devices, personnel and equipment must be grounded to prevent static discharge damage to the device.

NOTE

Prefix component reference designators of the audio interface with 4A1.

Clean the audio interface in accordance with TO 00-25-234.

e. Repair and Replacement. Repair of the audio interface consists of the removal of malfunctioning components and their replacement with serviceable components. Refer to IPB figure 7-26 for items that are SMR coded for repair at depot level. Upon receipt of an audio interface for repair at depot level, perform the following procedures:

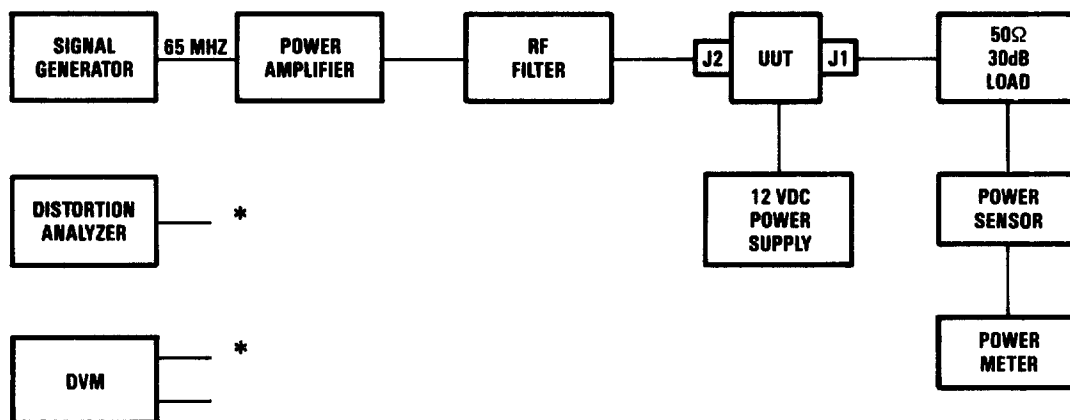

\* CONNECT AS REQUIRED BY TEST PROCEDURES

**CAUTION**  
 IF RF FILTER P/N SM-D-413503 OR EQUIVALENT IS NOT  
 USED, DAMAGE TO UUT WILL RESULT.

MX-61-119-038-1

Figure 5-19. FM BITE/Audio Interface 4A1 Bench Test Setup  
 (Sheet 1 of 2)

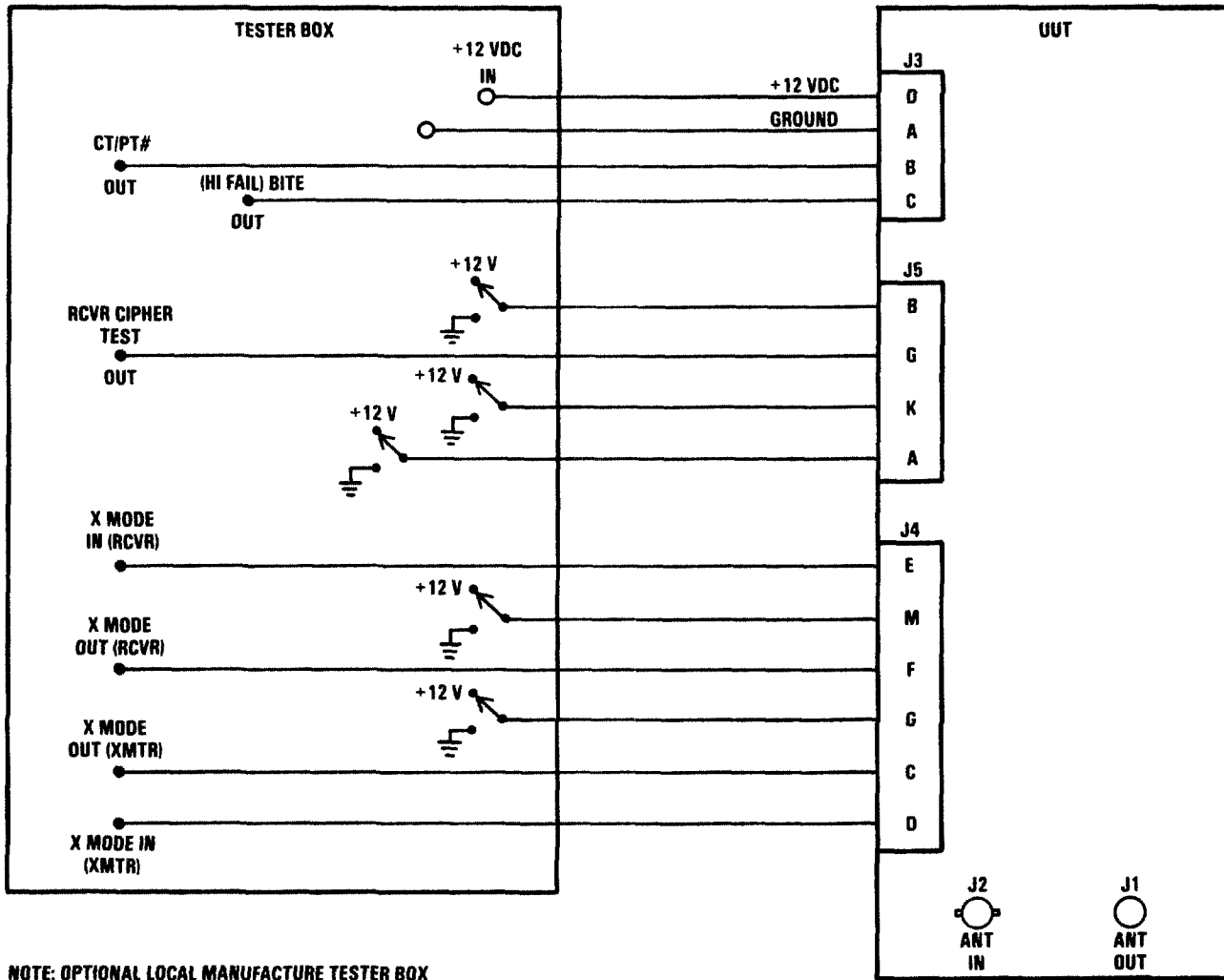

MX 61 110 036-2

Figure 5-19. FM BITE/Audio Interface 4A1 Bench Test Setup  
(Sheet 2 of 2)

**CAUTION**

The FM BITE/audio interface CGA is susceptible to electrostatic discharge damage. Prior to handling electrostatic-sensitive electronic devices, personnel and equipment must be grounded to prevent static discharge damage to the device.

- (1) Visually inspect audio interface for damage to components from heat, deterioration, moisture, or deposits from oxidation or corrosion.
- (2) Check for broken wires, bent pins, frayed insulation, and poor soldering connections.
- (3) Check printed wiring board for cracks or delamination.
- (4) Replace defective components. Refer to figures 5-20 and 7-26 for component location and orientation. Refer to table 5-21 and figure 5-21 for wiring information.
- (5) Apply a thin film of grease per MIL-G-4343 to O-rings of connectors J1 through J5.
- (6) Perform all soldering and other electronic maintenance in accordance with TO 00-26-234 per MIL-STD-454, Requirement 5. Use solder Type SN60WRMAP2 per QQ-S-571.
- (7) Use splices (20, figure 7-26) on the shields of wires that attach to receptacle connector AlP1 (20) pins 1 through 3, 8 through 11, 14, and 17 through 22.
- (8) Apply shrink sleeving to exposed ground shields on wires exiting from connectors J4 and J5.

f. Reassembly and Testing of Subassemblies and Assemblies. Refer to the above paragraph, Repair and Replacement, for special reassembly instructions of the audio interface.

g. Testing. Perform the instructions contained in table 5-17, FM BITE/Audio Interface Component Performance Tests, to ensure its serviceable condition.

Table 5-19. FM BITE/Audio Interface Performance Tests

| Step | Connection of test equipment                    | Point of test | Control settings and operation of equipment   | Performance standard                               |
|------|---|---------------|---|--|
| 1.   |   |               | Visually inspect FM BITE/audio interface for physical damage or corrosion.  | No damage or corrosion to FM BITE/audio interface. |
| 2.   | Connect test equipment as shown in figure 5-19. |               |   |  |
| 3.   |   |               | Apply ground to J3-A.<br>Apply +12V to J3-D.  |  |
|      |   |               | FM BITE CIRCUITRY TEST  |  |
| 4.   |   |               | Turn on RF generator and set frequency to 40 MHz, FM modulated at 1000 Hz.  |  |
| 5.   |   |               | Set signal amplitude for no more than -40.0 dBm input to BITE assembly. (Measure on input power meter after correcting for losses between directional coupler input and input power meter.) | J3-C > 3.5 VDC (LOGIC 1).                          |
| 6.   |   |               | Slowly increase amplitude.  | J3-C < 1.5 VDC (LOGIC 0).                          |
| 7.   |   |               | Read input power meter and correct for losses.  | 42.6 ± 1.0 dBm.                                    |
| 8.   |   |               | Slowly decrease signal generator amplitude.   | J3-C > 3.5 VDC (LOGIC 1).                          |

Table 5-19. FM BITE/Audio Interface Performance Tests - Continued

| Step | Connection of test equipment | Point of test   | Control settings and operation of equipment                   | Performance standard   |
|------|------------------------------|-----------------|---|--|
| 9.   |                              |                 | Read input power meter and correct for losses.                | 41.8 ± 1.0 dBm   |
|      |                              |                 | AUDIO INTERFACE TEST  |  |
| 10.  |                              |                 | Refer to figure FO-12 for pin locations.                      |  |
| 11.  |                              | J3-D.           | Ensure +12 VDC is applied.                                    |  |
| 12.  |                              | J3-A.           | Ensure ground is applied.                                     |  |
| 13.  | Signal generator.            | J4-E and ground | Apply signal form signal generator.                           | NOTE<br>This is the reference level for measurements in steps 18 through 28. |
| 14.  |                              |                 | Adjust distortion analyzer audio oscillator for audio signal. | 1000 Hz, 0.8 ± 0.2 Vrms to the UUT.  |
| 15.  |                              | J4-M.           | Apply ground (SQUELCH/DISABLE).                               |  |
| 16.  |                              | J4-G.           | Apply ground.   |  |
| 17.  |                              | J5-B.           | Apply +12 VDC.  |  |
| 18.  | Distortion analyzer.         | J5-G.           | Monitor pin output.   | Greater than or equal to -2.0 dB from reference.                             |
| 19.  |                              | J4-F.           |   | Greater than or equal to -2.0 dB from reference.                             |
| 20.  |                              |                 | Refer to figure 5-19 for optional test box.                   |  |
| 21.  |                              | J4-F.           | Apply ground to J5-B.   | No output.   |

Table 5-19. FM BITE/Audio Interface Performance Tests - Continued

| Step | Connection of test equipment          | Point of test | Control settings and operation of equipment | Performance standard                             |
|------|---------------------------------------|---------------|---|--|
| 22.  |                                       | J4-F.         | Apply +12 VDC to J4-G.                      | Audio out at J4-F is $0.8 \pm 0.2$ Vrms.         |
| 23.  |                                       |               | Apply ground to J4-G.                       |  |
| 24.  |                                       | J4-F.         | Apply +12 VDC to J4-M.                      | Audio out at J4-F is $0.8 \pm 0.2$ Vrms.         |
| 25.  |                                       |               | Verify signal generator output.             | 1000 Hz, $0.8 \pm 0.2$ Vrms.                     |
| 26.  | Signal generator to J4-D and ground.  | J4-D.         |   |  |
| 27.  | Power supply.                         |               | Apply +12 VDC to J5-K.                      |  |
| 28.  |                                       | J4-C.         |   | Greater than or equal to -2.0 dB from reference. |
| 29.  | Distortion analyzer audio oscillator. | J4-C.         | Apply ground to J5-K.                       | No output.                                       |
| 30.  | DVM.                                  | J3-B.         |   | Less than 1.5 VDC (LOGIC 0).                     |
| 31.  |                                       |               | Apply ground to J4-G.                       |  |
| 32.  | Power supply.                         |               | Apply +12 VDC to J5-A.                      |  |
| 33.  | DVM.                                  | J3-B.         |   | Greater than 3.5 VDC (LOGIC 1).                  |
| 34.  |                                       |               | Apply ground to J5-A.                       | Less than 1.5 VDC (LOGIC 0).                     |



Table 5-19. FM BITE/Audio Interface Performance Tests - Continued

| Step | Connection of test equipment | Point of test   | Control settings and operation of equipment  | Performance standard  |
|------|------------------------------|---|--|---|
| 35.  | DVM.                         | <p>J4-A to XA1P1-27</p> <p>J4-A to XA1P1-22</p> <p>J4-C to XA1P1-18</p> <p>J4-D to XA1P1-17</p> <p>J4-B to XA1P1-16</p> <p>ZA1P1-7 to J4-M</p> <p>XA1P1-7 to XA1P1-14</p> <p>J4-H to XA1P1-14</p> <p>J4-K to XA1P1-19</p> | <p>Shut off signal generator and power supply. Refer to figure FO-12 and perform continuity or resistance checks between the following points:</p> | <p>Continuity between listed points.</p> <p>1200 ohms resistance.</p> |
| 36.  |                              |   | Test is complete.  |   |

Table 5-20. FM BITE/Audio Interface Fault Isolation Tests

| Step                   | Procedure   | Normal indication                       | Fault location  |
|------------------------|---|---|---|
| 1.                     | Visually inspect FM BITE/audio interface for physical damage or corrosion.  | No damage or corrosion.                 | Repair damage or corrosion per TO 00-25-234.  |
| 2.                     | Connect equipment as described in table 5-19, steps 2 and 3. Apply ground to J3-A. Apply +12 VDC to J3-D.   |   |   |
| FM BITE CIRCUITRY TEST |   |   |   |
| 3.                     | Turn on RF generator and set frequency to 65 MHz.   |   |   |
| 4.                     | Set signal amplitude for no more than -40.0 dBm input to BITE assembly. (Measure on input power meter after correcting for losses between directional coupler input and input power meter.) | J3-C is greater than 3.5 VDC (LOGIC 1). |   |
| 5.                     | Slowly increase signal amplitude beyond -40.0 dBm.  | J3-C is less than 3.5 VDC (LOGIC 0).    | Check for at least $\pm 1.0$ VDC at TP2.<br>Absent: T1, C5, R10, R6, CR4, or L1.<br>Present: U3, Q1, R17, or associated circuitry.      |
| 6.                     | Read input power meter and correct for losses.  | $42.6 \pm 1.0$ dBm.                     |   |
| 7.                     | Slowly decrease signal amplitude.   | J3-C is less than 1.5 VDC (LOGIC 0).    | Check for at least +1.0 VDC at TP1.<br>Present: U3, Q1, R17, or associated circuitry.<br>Absent: CR1, CR2, CR3 or associated circuitry. |

Table 5-20. FM BITE/Audio Interface Fault Isolation Tests - Continued

| Step                 | Procedure  | Normal indication  | Fault location        |
|----------------------|--|--|-----------------------|
| 8.                   | Adjust the distortion analyzer audio oscillator for an audio output. | 1000 Hz, $0.8 \pm 0.2$ Vrms to the UUT.  |                       |
| 9.                   | Read input power meter and correct for losses.                       | $41.8 \pm 1.0$ dBm.  |                       |
| AUDIO INTERFACE TEST |  |  |                       |
| 10.                  | Refer to figure FO-12 for pin locations.                             |  |                       |
| 11.                  | Ensure +12 VDC is applied to J3-D.                                   |  |                       |
| 12.                  | Ensure ground is applied to J3-A.                                    |  |                       |
| 13.                  | Apply signal generator input to J4-E and ground.                     | NOTE<br><br>This is the reference level for measurements in steps 18 through 28. |                       |
| 14.                  | Adjust the distortion analyzer audio oscillator for audio signal.    | 1000 Hz, $0.8 \pm 0.2$ Vrms to the UUT.  |                       |
| 15.                  | Apply ground (SQUELCH/DISABLE) to J4-M.                              |  |                       |
| 16.                  | Apply ground to J4-G.  |  |                       |
| 17.                  | Apply +12 VDC to J5-B.   |  |                       |
| 18.                  | Monitor pin J5-G with distortion analyzer.                           | Greater than or equal to -2.0 dB from reference.                                 |                       |
| 19.                  | Monitor pin J4-F with distortion analyzer.                           | Greater than or equal to -2.0 dB from reference.                                 | U2, C7, R15, R16, C6. |

Table 5-20. FM BITE/Audio Interface Fault Isolation Tests - Continued

| Step | Procedure  | Normal indication  | Fault location                  |
|------|--|--|---------------------------------|
| 20.  | Refer to figure 5-19 for optional test box.  |  |                                 |
| 21.  | While monitoring J4-F, apply ground to J5-B.   | No output.   | U2.                             |
| 22.  | While monitoring J4-F, apply +12 VDC to J4-G.  | Audio out is $0.8 \pm 0.2$ Vrms.                         | U2, R15, CR6, R16, C6.          |
| 23.  | Apply ground to J4-G.  |  |                                 |
| 24.  | While monitoring J4-F, apply +12 VDC to J4-M.  | Audio out at J4-F is $0.8 \pm 0.2$ Vrms.                 | CR5, U2, R16, C6.               |
| 25.  | Verify signal generator output is 1000 Hz, $0.8 \pm 0.2$ Vrms.                           |  |                                 |
| 26.  | Signal generator output across J4-D and ground.  |  |                                 |
| 27.  | Apply +12 VDC to J5-K.   | J4-C is greater than or equal to -2.0 dB from reference. | C9, U2 or associated circuitry. |
| 28.  | While monitoring J4-C with a distortion analyzer audio oscillator, apply ground to J5-K. | No output.   | U2 or associated circuitry.     |
| 29.  | Measure between J3-B and ground with DVM.  | Less than 1.5 VDC (LOGIC 0).                             | U1, R1 or R2.                   |
| 30.  | Apply ground to J4-G.  |  |                                 |
| 31.  | Apply +12 VDC to J5-A.   |  |                                 |
| 32.  | Measure voltage between J3-B and ground with DVM.  | Greater than 3.5 VDC (LOGIC 1).                          | U1, U2 or associated circuitry. |

Table 5-20. FM BITE/Audio Interface Fault Isolation Tests - Continued

| Step | Procedure   | Normal indication   | Fault location |
|------|---|---|----------------|
| 33.  | Apply ground to J5A. Measure between J3-B and ground with DVM.  | Less than 1.5 VDC (LOGIC 0).<br><br><u>CAUTION</u><br><br>Ensure power and signal inputs are removed before doing continuity checks. Otherwise, damage to equipment may result. | Same as above. |
| 34.  | Shut off power supply and signal generator. Refer to figure FO-12 and perform continuity or resistance checks between the following points:<br><br>J4-A to XA1P1-27<br>J4-A to XA1P1-22<br>J4-C to XA1P1-18<br>J4-D to XA1P1-17<br>J4-B to XA1P1-16<br>XA1P1-7 to J4-M<br>XA1P1-7 to XA1P1-14<br>J4-H to XA1P1-14<br>J4-K to XA1P1-19 | 1200 ohms resistance.   | R3.            |
| 35.  | Test is complete.   |   |                |

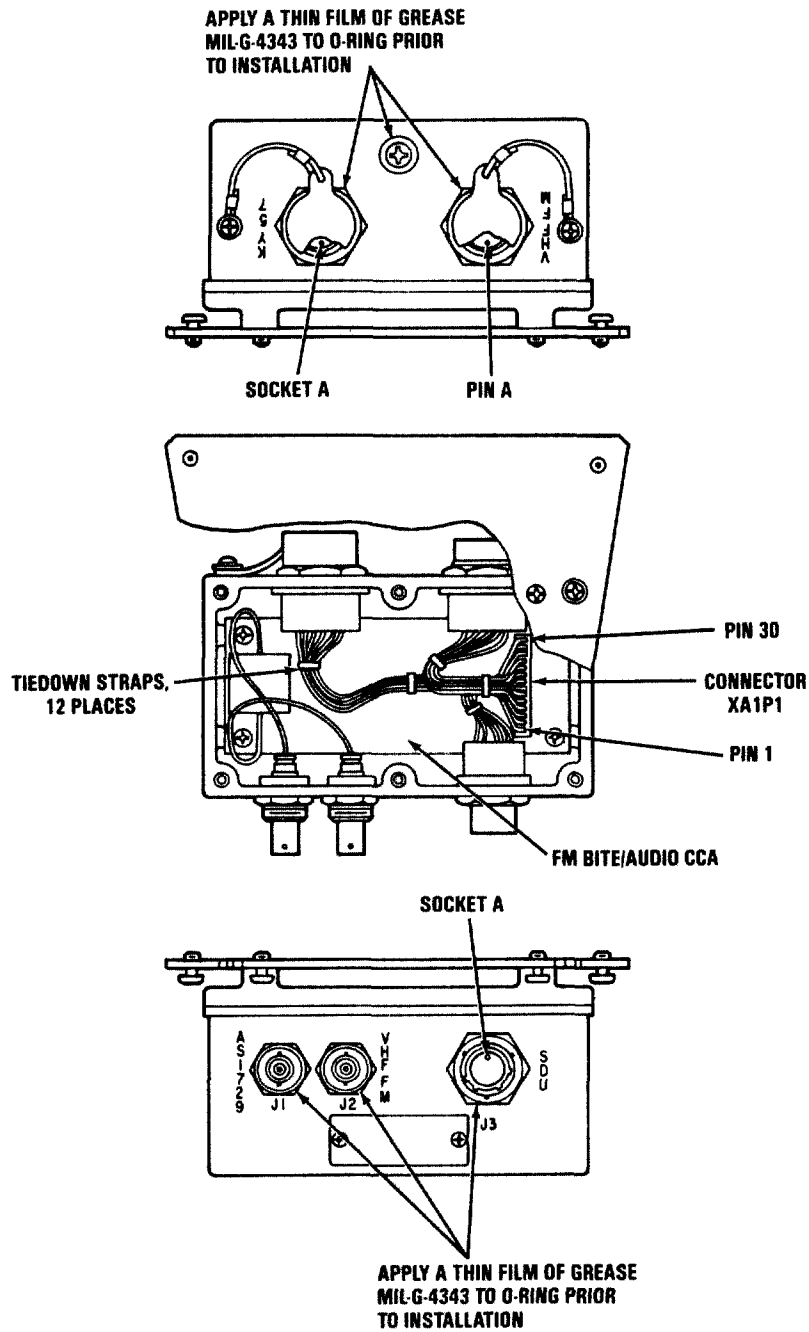

MX-01-118 037  
REF MX DWG NO. 012132 REV D

Figure 5-20. FM BITE/Audio Interface 4A1 Component Location

Table 5-21. FM BITE/Audio Interface Wiring List

| Wire No. | Gauge | Color       | From       | To         | Remarks              |
|----------|-------|-------------|------------|------------|----------------------|
| 1        | 22    | BLACK       | J3-A       | XA1P1-23   | GND                  |
| 2        | 22    | BLACK       | J3-E       | XA1P1-24   | DC RETURN            |
| 3        | 22    | ORANGE      | J3-D       | XA1P1-15   | +12V                 |
| 4        | 24    | WHT-RED     | J3-C       | XA1P1-30   | (HI-FAIL) BITE       |
| 5        | 24    | WHT-BLU     | J3-B       | XA1P1-5    | CT/PT#               |
| 6        | 24    | WHT-BLK     | J5-A       | XA1P1-6    | PT IND               |
| 7        | 24    | WHT-BRN     | J5-B       | XA1P1-7    | SQUELCH CONTROL      |
| 8        | 24    | RED         | J5-H       | XA1P1-16   | PTT                  |
| 9        | 24    | WHT (SHLD)  | J5-C       | XA1P1-17   | CIPHER TEXT OUT      |
| 10       | 24    | GRAY (SHLD) | J5-D       | XA1P1-18   | CTO1P                |
| 11       | 24    | VIO (SHLD)  | J5-E       | XA1P1-22   | PLAIN TEXT OUT       |
| 12       | 24    | BLU (SHLD)  | J5-F       | XA1P1-19   | RECEIVER PLAIN TEXT  |
| 13       | 24    | GRN (SHLD)  | J5-G       | XA1P1-9    | RECEIVER CIPHER TEXT |
| 14       | 24    | BLACK       | W13 (SHLD) | XA1P1-13   | GND                  |
| 15       | 24    | YELLOW      | J5-J       | XA1P1-27   | PTO RETURN           |
| 16       | 24    | BLACK       | J5-K       | XA1P1-26   | GND                  |
| 17       | 24    | BLACK       | J4-L       | W26 (SHLD) | GND                  |
| 18       | 24    | WHT-VIO     | J4-A       | XA1P1-12   | MIC AUDIO RETURN     |
| 19       | 24    | RED (SHLD)  | J4-H       | XA1P1-11   | TONE MODE            |
| 20       | 24    | BRN (SHLD)  | J4-G       | XA1P1-14   | TONE K401-5          |
| 21       | 24    | YEL (SHLD)  | J4-F       | XA1P1-10   | X MODE OUT (RCVR)    |
| 22       | 24    | BLU (SHLD)  | J4-E       | XA1P1-8    | X MODE IN (RCVR)     |
| 23       | 24    | ORN (SHLD)  | J4-K       | XA1P1-20   | UNMUTED AUDIO        |
| 24       | 24    | GRN (SHLD)  | J4-J       | XA1P1-21   | MIC AUDIO            |
| 25       | 24    | WHT (SHLD)  | J4-C       | XA1P1-3    | X MODE OUT (XMTR)    |
| 26       | 24    | VIO (SHLD)  | J4-D       | XA1P1-2    | X MODE IN (XMTR)     |
| 27       | 24    | GRAY (SHLD) | J4-B       | XA1P1-1    | R/T RELAY            |
| 28       | 24    | BLK         | W27 (SHLD) | W9 (SHLD)  | GND                  |
| 29       | 24    | WHT-YEL     | J4-M       | XA1P1-25   | SQUELCH DISABLE      |
| 30       | 24    | BLACK       | W13 (SHLD) | W12 (SHLD) | GND                  |
| 31       | 24    | BLACK       | W12 (SHLD) | W11 (SHLD) | GND                  |
| 32       | 24    | BLACK       | W11 (SHLD) | W10 (SHLD) | GND                  |
| 33       | 24    | BLACK       | W10 (SHLD) | W9 (SHLD)  | GND                  |
| 34       | 24    | BLACK       | W27 (SHLD) | W19 (SHLD) | GND                  |
| 35       | 24    | BLACK       | W19 (SHLD) | W20 (SHLD) | GND                  |
| 36       | 24    | BLACK       | W20 (SHLD) | W21 (SHLD) | GND                  |
| 37       | 24    | BLACK       | W21 (SHLD) | W22 (SHLD) | GND                  |
| 38       | 24    | BLACK       | W22 (SHLD) | W23 (SHLD) | GND                  |
| 39       | 24    | BLACK       | W23 (SHLD) | W24 (SHLD) | GND                  |
| 40       | 24    | BLACK       | W24 (SHLD) | W25 (SHLD) | GND                  |
| 41       | 24    | BLACK       | W25 (SHLD) | W26 (SHLD) | GND                  |

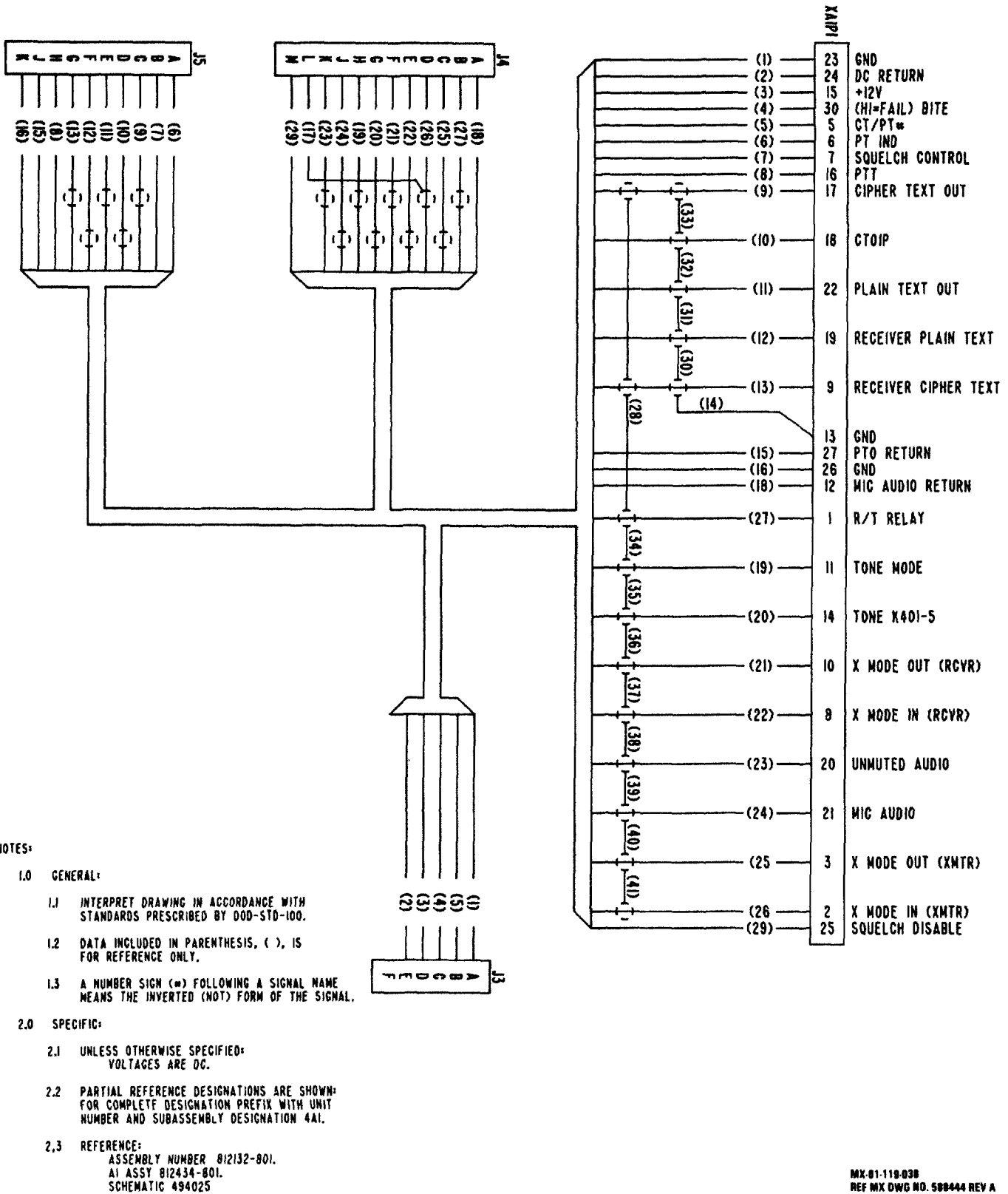

Figure 5-21. FM BITE/Audio Interface 4A1 Wiring Diagram



## 5-14. FM BITE/AUDIO CCA.

a. Bench Test Setup. The bench test setup of the audio CCA is illustrated in figure 5-19. The audio CCA is functionally checked during the FM BITE/audio interface performance test.

CAUTION

Prior to handling electrostatic-sensitive electronic devices, personnel and equipment must be grounded to prevent electrostatic discharge damage to the device. Do not remove or install subassembly in test fixture with power applied or damage to equipment may result.

NOTE

Subassemblies shipped in nonapproved containers may be subject to multiple failures due to mishandling.

b. Component Performance Test Table. The component performance test for the audio CCA are contained in table 5-19. This table is keyed to fault isolation procedures in table 5-20. The audio CCA is tested together with the FM BITE/Audio interface in these tables.

c. Mechanical Assemblies. NOT APPLICABLE

d. Cleaning and Lubrication.

CAUTION

Prior to handling electrostatic-sensitive electronic devices, personnel and equipment must be grounded to prevent static discharge damage to the device.

NOTE

Prefix component reference designators of the audio CCA with 4A1A1.  
Clean the audio CCA in accordance with TO 00-25-234.

e. Repair and Replacement. Repair of the audio CCA consists of the removal of malfunctioning components and their replacement with serviceable components. Refer to IPB figure 7-27 for items that are SMR coded for repair at depot level. Upon receipt of an audio CCA for repair at depot level, perform the following procedures:

CAUTION

Digital microcircuits U1 and U2 and semiconductor devices CR3 and CR4 are susceptible to electrostatic discharge damage. Prior to handling electrostatic-sensitive electronic devices, personnel and equipment must be grounded to prevent static discharge damage to the device.

- (1) Visually inspect CCA for damage to components or traces from heat, deterioration, moisture, or deposits from oxidation or corrosion.
- (2) Check for broken wires, bent pins, frayed insulation, and poor soldering connections.
- (3) Check printed wiring board for cracks or delamination.
- (4) Replace defective components. Refer to figures 5-22 and 7-27 for component location and orientation.
- (5) Perform all soldering and other electronic maintenance in accordance with TO 00-25-234 per MIL-STD-454, Requirement 5. Use solder Type SN6OWRMAP2 per QQ-S-571.
- (6) Except for indicated areas in figure 5-22, cover both sides of the CCA with conformal coating per MIL-I-46058, Type UR.

f. Reassembly and Testing of Subassemblies and Assemblies. Refer to the above paragraph, Repair and Replacement, for special reassembly instructions of the audio CCA.

g. Testing. Perform the instructions contained in table 5-19, FM/BITE Audio Interface Component Performance Tests, to ensure serviceable condition of the subassembly.

5-15. DISTRIBUTION BOX MAINTENANCE.

a. Bench Test Setup. The bench test setup of the distribution box is illustrated in figure 5-23.

b. Component Performance Test Table. The component performance tests for the distribution box are in table 5-22. This table is keyed to fault isolation procedures in table 5-23.

c. Mechanical Assemblies. NOT APPLICABLE

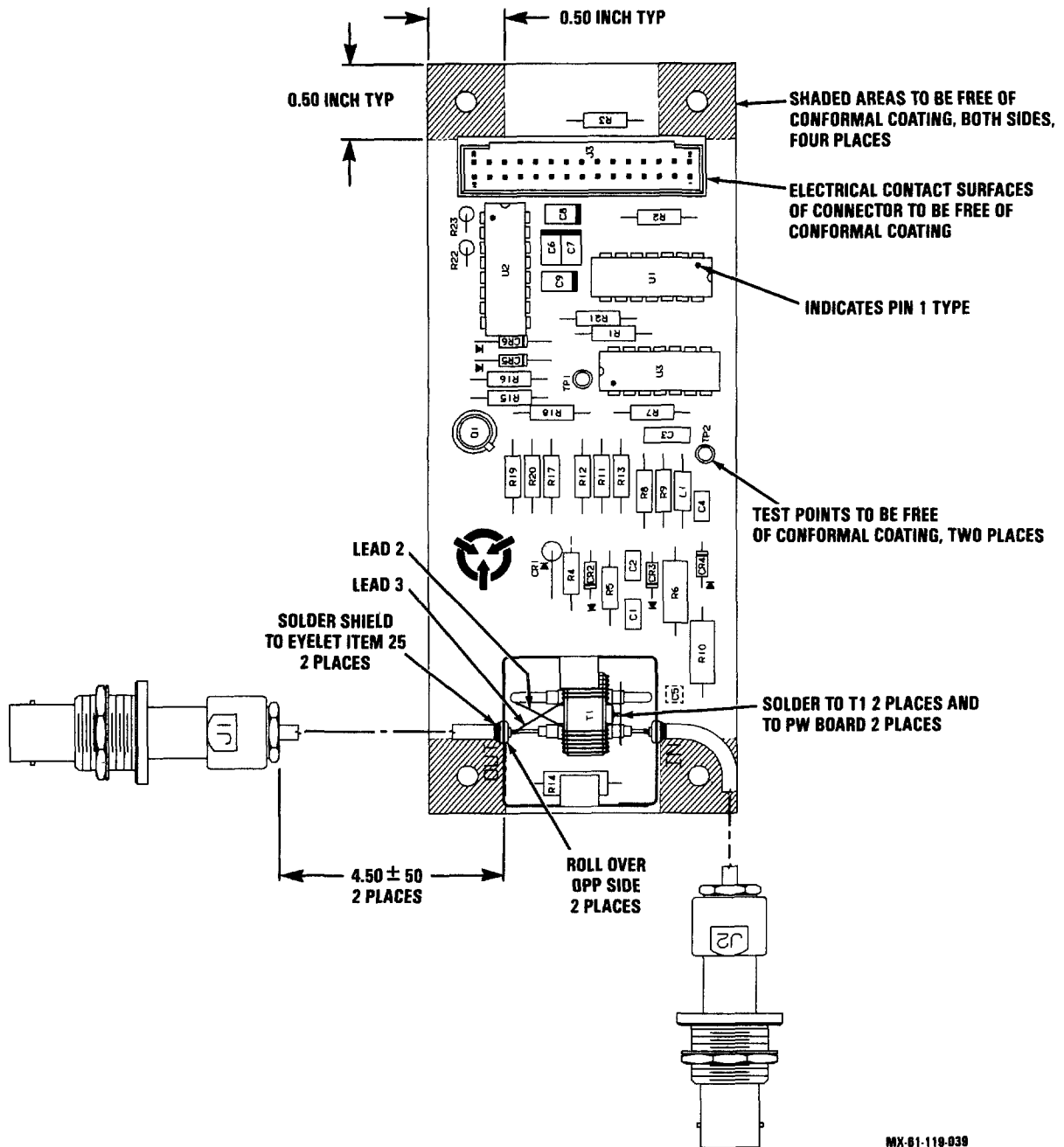

MX-81-118-039  
REF MX DWG NO. 812424 REV J

Figure 5-22. FM BITE/Audio Interface CCA 4A1A1 Component Location

d. Cleaning and Lubrication.

NOTE

Prefix component reference designators of the distribution box with 4A2.

Clean the distribution box in accordance with TO 00-25-234.

e. Repair and Replacement. Repair of the distribution box consists of the removal of malfunctioning components and their replacement with serviceable components. Refer to IPB figure 7-25 for items that are SMR coded for repair at depot level. Upon receipt of a distribution box for repair, perform the following procedures as required:

- (1) Visually inspect the distribution box for damaged or broken connectors or bent pins. Check for missing screws.
- (2) Replace unserviceable or missing parts.
- (3) Perform all continuity checks, soldering, and other electronic maintenance in accordance with TO 00-25-234 per MIL-STD-454, Requirement 5. Use solder Type SN60WRMAP2 per QQ-S-571.
- (4) Refer to table 5-24 for electrical wiring connection instructions.

f. Reassembly and Testing of Subassemblies and Assemblies. The reassembly instructions for the distribution box are provided under its paragraph covering Repair and Replacement.

g. Testing. Perform the instructions contained in table 5-22, Distribution Box Component Performance Tests, to ensure the serviceable condition of the subassembly.

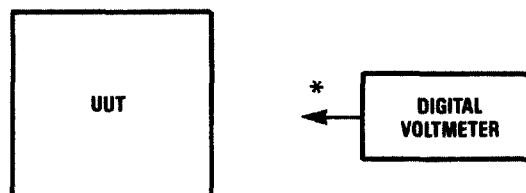

\* CONNECT AS DIRECTED IN PROCEDURE

MX-61-119-040

Figure 5-23. Distribution Box 4A2 Bench Test Setup

Table 5-22. Distribution Box Component Performance Tests

| Step | Connection of test equipment                    | Point of test | Control settings and operation of equipment                                     | Performance standard                                    |
|------|---|---------------|---|---|
| 1.   |   |               | Visually inspect electrical equipment chassis for physical damage or corrosion. | No corrosion or damage to electrical equipment chassis. |
| 2.   | Connect test equipment as shown in figure 5-23. |               |   |   |
| 3.   |   | Table 5-24.   | Check for continuity between each point listed.                                 | Continuity between each point is required.              |

Table 5-23. Distribution Box Fault Isolation Tests

| Step | Procedure  | Normal indication                 | Fault location                          |
|------|--|-----------------------------------|---|
| 1.   | Connect equipment as described in table 5-22.<br><br>NOTE<br><br>The two digits after the first hyphen designate the wire gauge. | Continuity between points tested. | Replace wiring as listed in table 5-24. |
| 2.   | Test is complete. Remove power and disconnect test equipment.  |                                   |   |

Table 5-24. Distribution Box Wiring List

| J1 Connections | Quantity | TB Connections                                     |
|----------------|----------|--|
| J1 - Pin A     | 2 ea.    | Red Wires 12 GA. to TB1<br>(Any pin holes on TB1). |
| Pin B          | 2 ea.    | Green Wires 12 GA to TB2<br>(To any pins on TB2).  |
| Pin C          | 2 ea.    | Black Wires 12 GA to TB3<br>(To any pins on TB3).  |

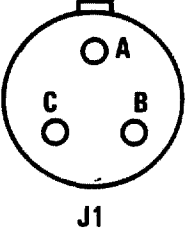

The diagram shows a circular connector labeled J1. It has three pins arranged in a triangle: Pin A is at the top, Pin B is at the bottom right, and Pin C is at the bottom left. Each pin is represented by a small circle with a dot in the center.

5-16. PDU ELECTRICAL EQUIPMENT CHASSIS MAINTENANCE.

a. Bench Test Setup. The bench test setup of the PDU chassis is illustrated in figure 5-24.

b. Component Performance Test Table. The component performance tests for the PDU chassis are in table 5-25. This table is keyed to fault isolation procedures in table 5-26.

c. Mechanical Assemblies. NOT APPLICABLE

d. Cleaning and Lubrication.

NOTE

Prefix component reference designators of the PDU chassis with the number 2.

Clean the PDU chassis in accordance with TO 00-25-234.

e. Repair and Replacement. Repair of the PDU chassis consists of the removal of malfunctioning components and their replacement with serviceable components. Refer to IPB figures 7-13 and 7-15 for items that are SMR coded for repair at depot level. Upon receipt of an electrical chassis for repair, perform the following procedures as required:

**CAUTION**

On the AN/GRC-206(V)5, when replacing the main PDU circuit breaker (CB1), retain the flat-head screws from the original circuit breaker and discard the new, round-head screws supplied with the new circuit breaker. The round-head screws extend too far above the body of the unit and can short out against the Power Reactor bulkhead.

- (1) Visually inspect the PDU chassis for damaged or broken connectors; bent pins; or broken lens, lamps, or switches. Check for missing screws.
- (2) Replace unserviceable or missing parts.
- (3) Perform all continuity checks, soldering, and other electronic maintenance in accordance with TO 00-25-234 per MIL-STD-454, Requirement 5. Use solder Type SN60WRMAP2 per QQ-S-571.
- (4) Refer to table 5-27 and FO-1 and 16 for electrical wiring connections and sleeving instructions.
- (5) Refer to figures 5-25, 7-13, and 7-15 for component location.
- (6) Apply a thin film of grease per MIL-C-4343 to O-rings of connectors (3 and 6, figure 7-15) prior to installation.
- (7) Apply shrink sleeving M23053/5 to solder cups of J1, J2, and J3 after soldering of wire.
- (8) Apply sealant, Grade AV, per MIL-S-22473 to threads of screws (2 and 3, figure 7-13) prior to installation.

f. Reassembly and Testing of Subassemblies and Assemblies. The reassembly instructions for the PDU chassis are provided under its paragraph covering Repair and Replacement.

g. Testing. Perform the instructions contained in table 5-25, PDU Electrical Equipment Chassis Component Performance Tests, to ensure the serviceable condition of the subassembly.

#### Section II. PERFORMANCE TEST CHECKS

5-17. General. The test procedures to ensure the serviceability of the depot repairable subassemblies are contained in the component test tables of Section I. Refer to the component test tables 5-1, 5-4, 5-6, 5-8, 5-10, 5-12, 5-14, 5-17, 5-19, 5-22, and 5-25 for performance test checks.

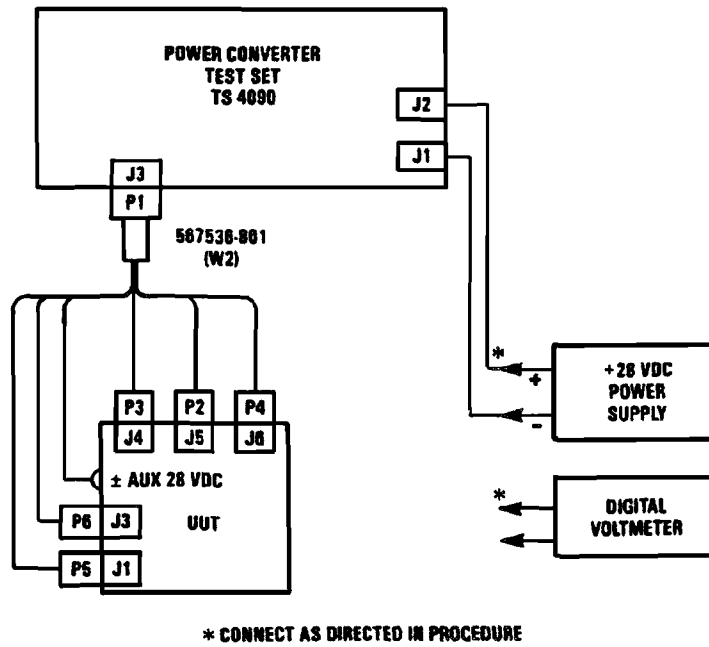

L0205124

Figure 5-24. PDU Electrical Equipment Chassis 2 Bench Test Setup



Table 5-25. PDU Electrical Equipment Chassis Component Performance Tests

| Step | Connection of test equipment                                     | Point of test  | Control settings and operation of equipment                                     | Performance standard                                    |
|------|--|--|---|---|
| 1.   | NOTE<br>Refer to figure 5-25 for reference designator locations. |  | Visually inspect electrical equipment chassis for physical damage or corrosion. | No corrosion or damage to electrical equipment chassis. |
| 2.   |  |  | Switch PDU circuit breakers CB1, CB2, and CB3 to RESET.                         |   |
| 3.   | Connect DVM leads.   | Across:<br>J5A: and<br>J6-A<br>E3<br>E5<br>J1-A<br>J2-A                        | Set DVM for continuity test.  | Continuity of less than two ohms.                       |
| 4.   | Connect DVM leads.   | Across:<br>J5-B: and<br>J6-C<br>E2<br>E5<br>E6<br>J1-B<br>J2-B<br>J4-B<br>J3-B |   | Continuity of less than two ohms.                       |
| 5.   |  |  | Switch CB1, CB2 and CB3 to the OFF position.                                    |   |
| 6.   | DVM, Test<br>Set TS 4090,<br>+28 VDC Power<br>Supply.            | Connect equipment as shown in figure 5-24.                                     |   |   |

Table 5-25. PDU Electrical Equipment Chassis Component Performance Tests-Continued

| Step | Connection of test equipment | Point of test          | Control settings and operation of equipment   | Performance standard  |
|------|------------------------------|------------------------|---|---|
| 7.   | +28 VDC Power Supply DVM.    |                        | <p style="text-align: center;"><u>CAUTION</u></p> <p>Ensure insulated leads are used to prevent shorting of +28 VDC supply.</p> <p>Turn power supply on and adjust for +28 VDC while monitoring TS4090 J1 and J2. Set up power supply for 25 amp current limit.</p> |   |
| 8.   | Test Set TS 4090.            |                        | <p style="text-align: center;"><u>WARNING</u></p> <p>The top of Power Converter Test Set TS4090 will be hot to the touch. Ensure the top remains clear for cooling purposes.</p> <p>Set switch S1 to AUX.</p>   |   |
| 9.   | PDU.                         |                        | <p>Set switch CB1 to the ON position.</p> <p>Set PDU switch CB1 to PWR RESET and switch S1 to AUX M/G.</p>  | <p>TS4090 test set lamp CR2 lights.</p> <p>PDU PWR ON indicator DS1 lights. Voltage meter M1 indicates +28 VDC.</p> |
| 10.  | DVM.                         |                        | <p>Readjust power supply for 28 VDC between TP1 and TP2.</p>  |   |
| 11.  | PDU.                         |                        | <p>Set PDU switch CB2 to RESET.</p>   |   |
| 12.  | DVM.                         | E3 to E4.<br>E5 to E6. |   | +28 ±1 VDC.   |

Table 5-25. PDU Electrical Equipment Chassis Component Performance Tests-Continued

| Step | Connection of test equipment | Point of test | Control settings and operation of equipment                 | Performance standard  |
|------|------------------------------|---------------|---|---|
| 13.  |                              |               | Set PDU switch CB2 to OFF.                                  |   |
| 14.  | PDU.                         |               | Set PDU switch S1 to VEHICLE.                               |   |
| 15.  | Test set TS4090.             |               | Set TS4090 test set S1 to MAIN, and S3 to VEHICLE OVERRIDE. | PWR ON indicator DS1 remains lit. Voltage meter M1 indicates +28 VDC. |
| 16.  | PDU.                         |               | Set PDU switch S1 to VEHICLE OVERRIDE.                      | PDU VEH OVRD indicator DS2 lights.                                    |
| 17.  | DVM.                         | TP6 and TP7.  | Set PDU switch CB1 OFF.                                     | DVM displays +28 $\pm$ 1 VDC.   |
| 18.  |                              |               | Test is complete.   |   |

Table 5-26. PDU Electrical Equipment Chassis Fault Isolation Tests

| Step | Procedure  | Normal indication  | Fault location  |
|------|--|--|---|
| 1.   | <p>Visually inspect electrical equipment chassis for physical damage or corrosion.</p> <p style="text-align: center;">NOTE</p> <p>Refer to figure 5-25 for reference designator locations.</p> | <p>No corrosion or damage to electrical equipment chassis.</p> | <p>Repair electrical equipment chassis in accordance with TO 00-25-234.</p> |
| 2.   | <p>Switch PDU circuit breakers CB1, CB2, and CB3 to RESET.</p>   |  |   |
| 3.   | <p>Set DVM for continuity test. Connect leads across: J5-A and J6-A<br/>E3<br/>E5<br/>J1-A<br/>J2-A.</p>   | <p>Continuity of less than two ohms.</p>                       | <p>CB1, K1 or L1.</p>   |
| 4.   | <p>Connect DVM leads across: J5-B and J6-C<br/>E2<br/>E5<br/>J1-B<br/>J2-B<br/>J4-B<br/>J3-B</p>   | <p>Continuity of less than 2 ohms.</p>                         | <p>Wiring.</p>  |
| 5.   | <p>Connect DVM leads across J4-A and J3-A.</p>   | <p>Continuity of less than two ohms.</p>                       | <p>CR2 or wiring.</p>   |
| 6.   | <p>Switch CB1, CB2 and CB3 to the OFF position.</p>  |  |   |
| 7.   | <p>Connect equipment as shown in figure 5-24.</p>  |  |   |

Table 5-26. PDU Electrical Equipment Chassis Fault Isolation Tests - Continued

| Step | Procedure  | Normal indication  | Fault location                       |
|------|--|--|--------------------------------------|
|      | <u>CAUTION</u>   |  |                                      |
|      | Ensure insulated leads are used to prevent shorting of +28 VDC power supply.   |  |                                      |
| 8.   | Turn power supply on and adjust for +28 VDC while monitoring TS 4090 J2 and J2 with DVM leads. Set up power supply for 25 amp current limit. |  |                                      |
|      | <u>WARNING</u>   |  |                                      |
|      | The top of Power Converter Test Set TS4090 will be hot to the touch. Ensure the top remains clear for cooling purposes.                      |  |                                      |
| 9.   | Set TS4090 switch S1 to AUX.   |  |                                      |
| 10.  | Set switch CB1 to the ON position.   | TS 4090 test set lamp CR2 lights.                                    |                                      |
| 11.  | Set PDU switch CB1 to PWR RESET and set switch S1 to AUX MOTOR GEN.  | PDU PWR ON indicator DS1 lights. Voltage meter M1 indicates +28 VDC. | DS1, M1, CB1, CR1, CR3, CR5, R1, C1. |
| 12.  | Using the DVM, readjust power supply for +28 VDC between TP1 and TP2.  |  |                                      |
| 13.  | Set PDU switch CB2 to RESET.   |  |                                      |
| 14.  | DVM leads across: E3 to E4<br>E5 to E6   | +28 VDC $\pm$ 1 VDC.   | CB2 or S1.                           |
| 15.  | Set PDU switch CB2 to OFF.   |  |                                      |
| 16.  | Set PDU switch S1 to VEHICLE.  |  |                                      |

Table 5-26. PDU Electrical Equipment Chassis Fault Isolation Tests

| Step | Procedure   | Normal indication   | Fault location |
|------|---|---|----------------|
| 17.  | Set TS4090 test set S1 to MAIN, and S2 to VEHICLE OVERRIDE.               | PWR ON indicator DS1 remains lit. Voltage meter M1 indicates +28 VDC. | S1.            |
| 18.  | Set PDU switch S1 to VEHICLE OVERRIDE.                                    | PDU VEH OVRD indicator DS2 lights.                                    | DS2, S1, K1.   |
| 19.  | Connect DVM leads to TS4090 test set TP6 and TP7. Set PDU switch CB1 OFF. | DVM displays +28 $\pm$ 1 VDC.   | CB1, S1, K1.   |
| 20.  | Test is complete. Remove power and disconnect test equipment.             |   |                |

Table 5-27. PDU Electrical Equipment Chassis Wiring List

| Wire No. | Part No.       | Color | From       | To      | Remarks                       |
|----------|----------------|-------|------------|---------|-------------------------------|
| 1        | M22759/11-12-2 | RED   | A1J5-A     | A2K1-A3 | +28V (AUX GEN)                |
| 2        | M22759/11-12-2 | RED   | A1J5-A     | A2K1-A3 | +28V (AUX GEN)                |
| 3        | M22759/11-16-2 | RED   | A2K1-A3    | A2CR3-A | +28V                          |
| 4        | M22759/11-12-0 | BLACK | A1J5-B     | E7      | DC RTN (AUX GEN)              |
| 5        | M22759/11-12-0 | BLACK | A1J5-B     | E7      | DC RTN (AUX GEN)              |
| 6        | M22759/11-12-0 | BLACK | A1J4-B     | E7      | DC RTN (VEHICLE)              |
| 7        | M22759/11-12-0 | BLACK | A1J4-B     | E7      | DC RTN (VEHICLE)              |
| 8        | M22759/11-22-0 | BLACK | A1S1A-3    | E7      | DC RTN (VEHICLE)              |
| 9        | M22759/11-16-0 | BLACK | A1J3-B     | E7      | DC RTN (REF FREQ OSC)         |
| 10       | M22759/11-18-0 | BLACK | A1CB1-A2   | E7      | DC RTN (REF FREQ OSC)         |
| 11       | M22759/11-14-0 | BLACK | A1CR5-A    | E7      | DC RTN (REF FREQ OSC)         |
| 12       | M22759/11-20-0 | BLACK | A1XDS1-OTR | E7      | DC RTN (REF FREQ OSC)         |
| 13       | M22759/11-20-0 | BLACK | A1M1-      | E7      | DC RTN (REF FREQ OSC)         |
| 14       | M22759/11-12-5 | GREEN | A1J6-B     | E8      | CHASSIS GROUND (SYSTEM POWER) |
| 15       | M22759/11-12-5 | GREEN | A1J6-B     | E8      | CHASSIS GROUND (SYSTEM POWER) |
| 19       | M22759/11-16-0 | BLACK | A1J1-B     | E7      | DC RTN (ACCESSORIES)          |
| 20       | M22759/11-16-0 | BLACK | A1J2-B     | E7      | DC RTN (ACCESSORIES)          |
| 21       | M22759/11-12-0 | BLACK | A1J6-C     | E7      | DC RTN (SYSTEM POWER)         |
| 22       | M22759/11-12-0 | BLACK | A1J6-C     | E7      | DC RTN (SYSTEM POWER)         |
| 23       | M22759/11-16-5 | GREEN | A1J3-C     | E8      | CHASSIS GROUND (REF FREQ OSC) |
| 24       | M22759/11-12-5 | GREEN | A1J5-C     | E8      | CHASSIS GROUND (AUX GEN)      |
| 25       | M22759/11-12-5 | GREEN | A1J5-C     | E8      | CHASSIS GROUND (AUX GEN)      |
| 26       | M22759/11-12-5 | GREEN | A1J4-C     | E8      | CHASSIS GROUND (VEHICLE)      |
| 27       | M22759/11-12-5 | GREEN | A1J4-C     | E8      | CHASSIS GROUND (VEHICLE)      |
| 28       | M22759/11-12-2 | RED   | A2K1-A1    | A1J4-A  | +28V (VEHICLE)                |
| 29       | M22759/11-12-2 | RED   | A2K1-A1    | A1J4-A  | +28V (VEHICLE)                |
| 30       | M22759/11-16-2 | RED   | A2K1-A1    | A2CR2-A | +28V (VEHICLE)                |
| 31       | M22759/11-22-2 | RED   | A2K1-A1    | A1S1B-9 | +28V (VEHICLE)                |
| 32       | M22759/11-22-9 | WHITE | A1J4-D     | A1S1A-2 | RUN/RUN# (GND/OPEN) (VEHICLE) |
| 33       | M22759/11-16-2 | RED   | A2K1-X1    | A2CR2-C | +28V                          |
| 34       | M22759/11-16-2 | RED   | A2K1-X1    | A2CR3-C | +28V                          |
| 35       | M22759/11-20-2 | RED   | A2K1-X1    | A2CR4-C | +28V                          |
| 36       | M22759/11-16-2 | RED   | A2K1-X1    | A1J3-A  | +28V (REF FREQ OSC)           |
| 37       | M22759/11-22-0 | BLACK | A2K1-X2    | A1S1A-4 | DC RTN                        |
| 38       | M22759/11-20-0 | BLACK | A2K1-X2    | A2CR4-A | DC RTN                        |
| 39       | M22759/11-20-0 | BLACK | A1XDS2-OTR | E7      | DC RTN                        |
| 40       | M22759/11-22-2 | RED   | A1XDS2-CTR | A1S1B-8 | +28V (VEHICLE)                |

Table 5-27. PDU Electrical Equipment Chassis Wiring List - Continued

| Wire No. | Part No.       | Color | From     | To         | Remarks             |
|----------|----------------|-------|----------|------------|---------------------|
| 41       | M22759/11-18-0 | BLACK | A2CR1-A  | A1CB1-A1   | DC RTN              |
| 42       | M22759/11-12-2 | RED   | A1CB1-B2 | L1-2       | +28V (SYSTEM POWER) |
| 43       | M22759/11-12-2 | RED   | A1CB1-B2 | L1-2       | +28V (SYSTEM POWER) |
| 44       | M22759/11-14-2 | RED   | A1CB1-B2 | A2CR5-C    | +28V (SYSTEM POWER) |
| 45       | M22759/11-20-2 | RED   | A1CB1-B2 | A1XDS1-CTR | +28V (SYSTEM POWER) |
| 46       | M22759/11-20-2 | RED   | A1CB1-B2 | A1M1 +     | +28V (SYSTEM POWER) |
| 47       | M22759/11-12-2 | RED   | A1CB1-B1 | A2K1-A2    | +28V (SYSTEM POWER) |
| 48       | M22769/11-12-2 | RED   | A1CB1-B1 | A2K1-A2    | +28V (SYSTEM POWER) |
| 49       | M22759/11-18-2 | RED   | A2K1-A4  | A1CR1-C    | +28V (SYSTEM POWER) |
| 50       | M22759/11-16-2 | RED   | A1CB1-B1 | A1CB2-LE   | +28V (SYSTEM POWER) |
| 51       | M22759/11-16-2 | RED   | A2K1-A2  | A1CB3-LE   | +28V (SYSTEM POWER) |
| 52       | M22759/11-12-2 | RED   | A2K1-A2  | A2K1-A4    | +28V (SYSTEM POWER) |
| 53       | M22759/11-12-2 | RED   | A2K1-A2  | A2K1-A4    | +28V (SYSTEM POWER) |
| 54       | M22759/11-16-2 | RED   | A1CB3-LD | A1J1-A     | +28V (ACCESSORIES)  |
| 55       | M22759/11-16-2 | RED   | A1CB3-LD | A1J2-A     | +28V (ACCESSORIES)  |
| 56       | M22759/11-16-2 | RED   | A1CB2-LD | A1E1       | +28V (ACCESSORIES)  |
| 57       | M22759/11-16-2 | RED   | A1CB2-LD | A1E3       | +28V (ACCESSORIES)  |
| 58       | M22759/11-16-2 | RED   | A1CB2-LD | A1E5       | +28V (ACCESSORIES)  |
| 59       | M22759/11-12-2 | RED   | A1J6A    | L1-1       |                     |
| 60       | M22759/11-12-2 | RED   | A1J6A    | L1-1       |                     |
| 61       | M22759/11-16-2 | RED   | L1-1     | C1+        |                     |
| 62       | M22759/11-16-0 | BLACK | C1-      | E7         |                     |

## NOTES:

1. INTERPRET DRAWING IN ACCORDANCE WITH STANDARDS PRESCRIBED BY DOD-STD-100.
2. DATA INCLUDED IN PARENTHESIS, (), IS FOR REFERENCE ONLY.
3. A NUMBER SIGN (#) FOLLOWING A SIGNAL NAME MEANS THE INVERTED (NOT) FORM OF THE SIGNAL.
4. UNLESS OTHERWISE SPECIFIED, VOLTAGES ARE DC.
5. WIRE PROCESSING, SOLDERING, AND WORKMANSHIP TO BE PER MIL-STD-454, REQUIREMENTS 5, 9, AND 20.
6. PARTIAL REFERENCE DESIGNATIONS ARE SHOWN, FOR COMPLETE DESIGNATION, PREFIX WITH UNIT NUMBER AND SUBASSEMBLY DESIGNATION 2.



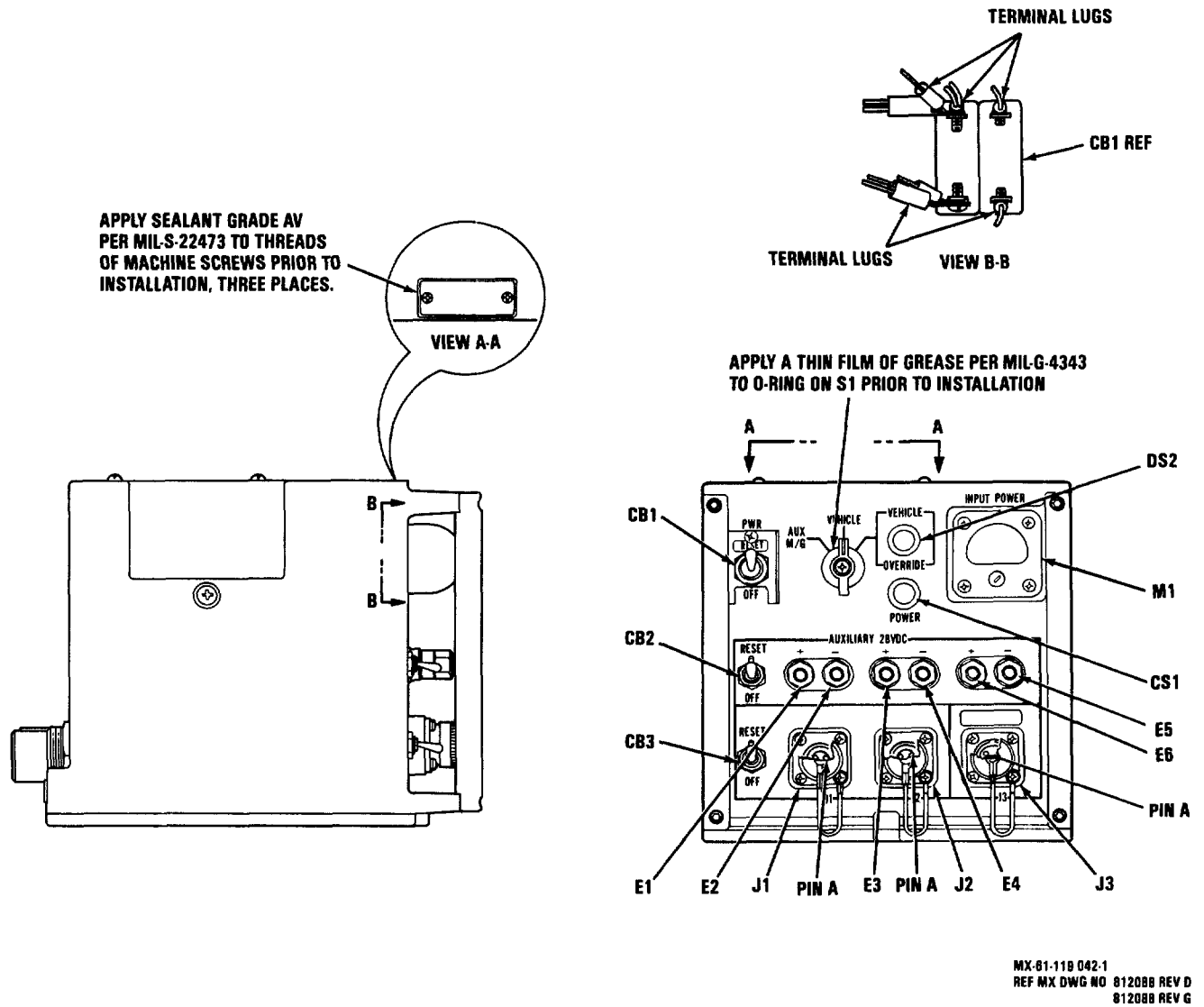

Figure 5-25. PDU Electrical Equipment Chassis 2 Component Location (Sheet 1 of 2)

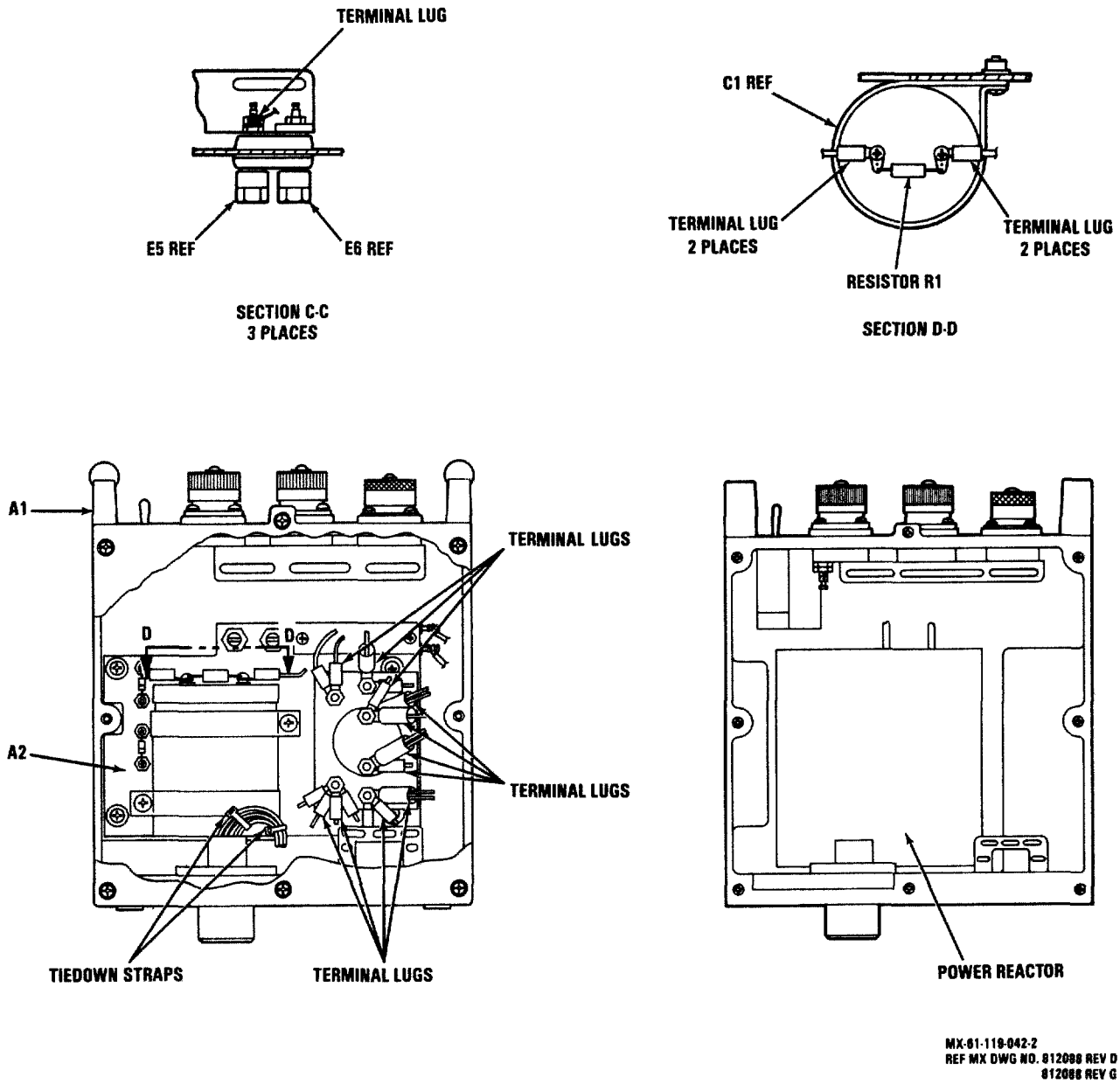

Figure 5-25. PDU Electrical Equipment Chassis 2 Component Location (Sheet 2 of 2)

CHAPTER 6

CIRCUIT DIAGRAMS

6-1. GENERAL. To assist technicians in understanding functions of the Radio System depot level SRU's, diagrams and schematics are integrated within the text pages of chapters 4 and 5. Oversized circuit diagrams and schematics referenced within chapters 4 and 5 are located at the rear of the manual; refer to figures FO-1 and FO-17.



## CHAPTER 7

## ILLUSTRATED PARTS BREAKDOWN

## Section I. INTRODUCTION

7-1. GENERAL. This Illustrated Parts Breakdown lists, illustrates and describes the parts used in Radio Communication System AN/GRC-206(V)1 and AN/GRC-206(V)2 manufactured by the Magnavox Government and Industrial Electronics Company, Fort Wayne, Indiana.

7-2. MAINTENANCE PARTS LIST. The Maintenance Parts List (MPL), (Chapter 7, Section II), consists of the complete Radio Communication System AN/GRC-206(V)1 and AN/GRC-206(V)2 divided into main groups. The main groups are broken down into assemblies, subassemblies and details. Each item is arranged to indicate its relationship to its next higher assembly. Each of the assemblies and subassemblies listed is followed immediately by its component parts. The relationship of the first item of each separately illustrated assembly or subassembly to its next higher assembly is indicated followed by the nomenclature of the first item. In general, the assemblies and parts installed at the time the end item was manufactured are listed and identified in the manual. When an assembly or part (including vendor items) which is different from the original was installed during manufacture of the later items, series, or blocks, all assemblies and parts are listed (and "Usable on" Coded). However, when the original assembly or part does not have continued application (no spares of the original were procured or such spares are no longer authorized for replacement), only the preferred assembly or part is listed. Interchangeable and substitute assemblies and parts, subsequently authorized by the Government, are not listed in this manual; such items are identified by information available through the Interchangeable and Substitute (I & S) Data Systems. Refer to T.O. 00-25-184. When a standard size part can be replaced with an oversize or undersize part, the latter parts, showing sizes, are also listed. Repair Parts Kits and Quick Change Units are listed when they are available for replacement.

a. Figure and Index Number Column. This column lists the figure and index number of each part illustrated in the corresponding figure. The index numbers are in numerical sequence and indicate the order of disassembly except where the order of disassembly does not apply. Index numbers identify each part shown in the corresponding figure, with the exception of subassemblies and attaching parts which are not illustrated separately. In these cases they are listed, but not indexed. When a group of parts (bolt, washer, nut) is used at a specific location for attachment purposes, one index number assigned to the group is sufficient. The index number appears on the same line as the first part composing the group.

b. Part Number Column. This column lists the drawing number (Part Number) including dash numbers, assigned to each part and vendor part numbers of parts used by the manufacturer's exactly as produced by the respective vendor. Those parts which have Government Standards numbers assigned to them have the Government Standards number listed. Parts altered or selected for special fit, tolerance, etc., from vendor, commercial or government standard items have

contractor part numbers. The vendor, commercial or Government Standards part number of the altered or selected part follow the part description in the Description column. Alternate vendor items, installed during manufacturing or modification, will be listed and identified as alternate by an (=) sign preceding the part number one space to the left.

Item(s) of supply part number(s) and FSCM that is stocked; stored and issued by the Government as identified by the Government during the initial provisioning process shall be identified by an (\*) sign preceding the part number one space to the left. Select at test items installed during manufacturing or modification, will be listed and identified as selected by an (+) sign preceding the part number one space to the left. Government Furnished Equipment (GFE) and Contractor Furnished Equipment (CFE), covered by separate manuals will be listed and identified by a number sign (#) inserted flush right following the part number. Decalcomania, metalcalcs, and vinyl film markings are considered parts. The part number for each marking appears in the part number column and is followed (flush right) by an asterisk (\*) symbol. This symbol means "requisition the marking in accordance with the requirements of ARF6-1."

c. FSCM Column. This column lists a 5-digit code number denoting the vendor from whom the part may be procured is shown following the part number. The source of vendor code numbers is the Federal Supply Code for Manufacturers (FSCM) Cataloging Handbooks, H4-1 H4-2 and H4-3.

d. Description Column. This column contains the description of all item appearing on the Maintenance Parts List. The indentation headed "1" through "7", in this column shows the relationship of parts and subassemblies to assemblies. The description consists of the approved item name, as found in the Federal Item Identification Guide for Supply Cataloging Handbook H6-1, or is in accordance with the manufacturer's drawing title, plus modifiers that are necessary to identify the particular item. Additional information may follow the item description and list of alternate part numbers, as required to give stock ordering information, exceptions to the Usable On Code for the item, references to preceding subsequent figures concerning assemblies and subassemblies, etc. These data are to be considered an integral part of the item description to assure the correctness of repair maintenance procedures. Item(s) identified as a Hardness Critical Item (HCI), the marking HCI (reference DOD-STD-100) shall precede the first word in the Description column.

This equipment contains electrostatic devices (ESDS). Special handling methods and materials must be utilized to prevent equipment damage. Refer to applicable maintenance section before assembly/disassembly or repair is performed. Assemblies that contain ESDS devices reflect (ESDS) in the description column.

e. Attaching Parts. These are items used to attach parts or assemblies to each other and are listed immediately after the part to be attached. The attaching parts have the same indentation code as the parts attached. The code (AP) appears on the same line with and immediately following the item identified as an attaching part.

f. Units Per Assembly. This column contains the number of units required per assembly and/or subassembly. If more than one assembly is required, the total number of assemblies is listed. When an assembly or subassembly is listed more than once, the total number of units per assembly or subassembly appears the first time and REF for subsequent listings.

g. Usable On Code. This column shows the Usable On Codes for systems, assemblies and parts to indicate specific usability by part number. Explanations of the usable on codes are provided at the bottom of the applicable page. The codes A, B, C etc., when shown within a group relate the part back to the same coded part within the next higher assembly. When this column is left blank, an assembly or part is common to all part number variations of the next higher assembly.

h. Source, Maintenance and Recoverability SMR Codes. This manual contains Joint Military Services Uniform SMR Codes. Detailed coding criteria may be obtained from T.O. 00-25-195.

i. Separate IPB Manuals. This list provides in alpha-numeric sequence the part number of the accessories, components, assemblies, and vendor items for which there are separate IPB Manuals. These components are noted in the MPL by the number sign (#) symbol following the part number.

| <u>Part Number</u>        | <u>IPB Manuals</u>                                    |
|---------------------------|---|
| 626701-1(AM-7148/GRC-206) | TO 31R2-2GRC206-22<br>Antenna-Coupler                 |
| 707123-802(AN/VRC-83)     | TO 31R2-2VRC83-3<br>Radio, Vehicle                    |
| 812118-801 (RT-1444/URC)  | TO 31R2-2PRC104-4-1<br>Receiver-Transmitter,<br>Radio |

7-3. NUMERICAL INDEX. The Numerical Index (Chapter 7, Section III) is compiled in accordance with the numerical part number filing system described in paragraph a.

a. Part Number Column. This column contains all the part numbers that appear in the Maintenance Parts List and part numbers that have been assigned to detail parts assembled into the end article. The order of procedure establishing the sequence in which the part numbers are listed is explained below. The order of precedence in the first position of each part number are listed is explained below. The order of precedence in the first position of each part number is Letters A through Z, Numerals 0 through 9.

#### NOTE

Alphabetical 0's are considered as numerical zeroes in all positions in each part number.

The order of precedence in the second and succeeding positions in each part number is as follows:

- (1) Space (blank column).
- (2) Diagonal (\).
- (3) Period (.)
- (4) Dash (-).
- (5) Letters A through Z.
- (6) Numerals 0 through 9.

The following is a sample of part numbers arranged in sequence used in the Numerical Index.

|            |        |          |
|------------|--------|----------|
| AN931-4-13 | B2     | 16.W2    |
| A2460      | S/1    | 16W060   |
| A317       | 1140   | 32P010-1 |
| A32        | 121873 | 32P0101  |
| B12        | 128    | 39A45    |

b. Figure and Index Number Column. For each part number, the figure or figure and index number refers to the Maintenance Parts List where parts relationship is shown. For Government Standard parts and manufacturer standard parts only, the first figure and index number that occurs will be listed. When an assembly or part has not been assigned an index number, the figure and index number of the preceding part in the Maintenance Parts List is used with the letter "F" before the figure number, such as F7-6. The letter "F" denotes "follows".

7-4. REFERENCE DESIGNATION INDEX. The Reference Designation Index (Chapter 7, Section IV) lists, in alphabetical-numerical order, the reference designations used in schematic diagrams and instruction books. Opposite the reference designation is listed the figure index number as shown in the Maintenance Parts List.



HOW TO USE THE ILLUSTRATED PARTS BREAKDOWN

IF PART NUMBER IS NOT KNOWN. . . . **Do This**

LIST OF ILLUSTRATIONS

| Figure No. | Title  | Page  |
|------------|--|-------|
| 2-1        | Stick Landing Gear Installation  | 2-1   |
| 2-2        | Emergency Brake Lever Assembly   | 2-1   |
| 2-3        | Stick Wheel Steering Installation  | 2-1   |
| 2-4        | Stick Landing Gear Hydraulic and Brake Operating Installation                      | 2-1   |
| 2-5        | Stick Landing Gear Hydraulic and Brake Operating Installation (Forward)            | 2-1   |
| 2-6        | Left Stick Side Landing Gear Hydraulic and Brake Operating Installation (Forward)  | 2-1   |
| 2-7        | Right Stick Side Landing Gear Hydraulic and Brake Operating Installation (Forward) | 2-1   |
| 2-8        | Stick Landing Gear Hydraulic and Brake Operating Installation (Forward)            | 2-1   |
| 2-9        | Stick Landing Gear Hydraulic and Brake Operating Installation (Forward)            | 2-1   |
| 2-10       | Stick Landing Gear Hydraulic and Brake Operating Installation (Forward)            | 2-1   |
| 2-11       | Stick Landing Gear Hydraulic and Brake Operating Installation (Forward)            | 2-1   |
| 2-12       | Stick Landing Gear Hydraulic and Brake Operating Installation (Forward)            | 2-1   |
| 2-13       | Stick Landing Gear Hydraulic and Brake Operating Installation (Forward)            | 2-1   |
| 2-14       | Stick Landing Gear Hydraulic and Brake Operating Installation (Forward)            | 2-1   |
| 2-15       | Stick Landing Gear Hydraulic and Brake Operating Installation (Forward)            | 2-1   |
| 2-16       | Stick Landing Gear Hydraulic and Brake Operating Installation (Forward)            | 2-1   |
| 2-17       | Stick Landing Gear Hydraulic and Brake Operating Installation (Forward)            | 2-1   |
| 2-18       | Stick Landing Gear Hydraulic and Brake Operating Installation (Forward)            | 2-1   |
| 2-19       | Stick Landing Gear Hydraulic and Brake Operating Installation (Forward)            | 2-1   |
| 2-20       | Stick Landing Gear Hydraulic and Brake Operating Installation (Forward)            | 2-1   |
| 2-21       | Stick Landing Gear Hydraulic and Brake Operating Installation (Forward)            | 2-1   |
| 2-22       | Stick Landing Gear Hydraulic and Brake Operating Installation (Forward)            | 2-1   |
| 2-23       | Stick Landing Gear Hydraulic and Brake Operating Installation (Forward)            | 2-1   |
| 2-24       | Stick Landing Gear Hydraulic and Brake Operating Installation (Forward)            | 2-1   |
| 2-25       | Stick Landing Gear Hydraulic and Brake Operating Installation (Forward)            | 2-1   |
| 2-26       | Stick Landing Gear Hydraulic and Brake Operating Installation (Forward)            | 2-1   |
| 2-27       | Stick Landing Gear Hydraulic and Brake Operating Installation (Forward)            | 2-1   |
| 2-28       | Stick Inst., Pilots Control  | 2-272 |
| 2-29       | Stick Landing Gear Hydraulic and Brake Operating Installation (Forward)            | 2-1   |
| 2-30       | Stick Landing Gear Hydraulic and Brake Operating Installation (Forward)            | 2-1   |
| 2-31       | Stick Landing Gear Hydraulic and Brake Operating Installation (Forward)            | 2-1   |
| 2-32       | Stick Landing Gear Hydraulic and Brake Operating Installation (Forward)            | 2-1   |
| 2-33       | Stick Landing Gear Hydraulic and Brake Operating Installation (Forward)            | 2-1   |
| 2-34       | Stick Landing Gear Hydraulic and Brake Operating Installation (Forward)            | 2-1   |
| 2-35       | Stick Landing Gear Hydraulic and Brake Operating Installation (Forward)            | 2-1   |
| 2-36       | Stick Landing Gear Hydraulic and Brake Operating Installation (Forward)            | 2-1   |
| 2-37       | Stick Landing Gear Hydraulic and Brake Operating Installation (Forward)            | 2-1   |
| 2-38       | Stick Landing Gear Hydraulic and Brake Operating Installation (Forward)            | 2-1   |
| 2-39       | Stick Landing Gear Hydraulic and Brake Operating Installation (Forward)            | 2-1   |
| 2-40       | Stick Landing Gear Hydraulic and Brake Operating Installation (Forward)            | 2-1   |
| 2-41       | Stick Landing Gear Hydraulic and Brake Operating Installation (Forward)            | 2-1   |
| 2-42       | Stick Landing Gear Hydraulic and Brake Operating Installation (Forward)            | 2-1   |
| 2-43       | Stick Landing Gear Hydraulic and Brake Operating Installation (Forward)            | 2-1   |
| 2-44       | Stick Landing Gear Hydraulic and Brake Operating Installation (Forward)            | 2-1   |
| 2-45       | Stick Landing Gear Hydraulic and Brake Operating Installation (Forward)            | 2-1   |
| 2-46       | Stick Landing Gear Hydraulic and Brake Operating Installation (Forward)            | 2-1   |
| 2-47       | Stick Landing Gear Hydraulic and Brake Operating Installation (Forward)            | 2-1   |
| 2-48       | Stick Landing Gear Hydraulic and Brake Operating Installation (Forward)            | 2-1   |
| 2-49       | Stick Landing Gear Hydraulic and Brake Operating Installation (Forward)            | 2-1   |
| 2-50       | Stick Landing Gear Hydraulic and Brake Operating Installation (Forward)            | 2-1   |
| 2-51       | Stick Landing Gear Hydraulic and Brake Operating Installation (Forward)            | 2-1   |
| 2-52       | Stick Landing Gear Hydraulic and Brake Operating Installation (Forward)            | 2-1   |
| 2-53       | Stick Landing Gear Hydraulic and Brake Operating Installation (Forward)            | 2-1   |
| 2-54       | Stick Landing Gear Hydraulic and Brake Operating Installation (Forward)            | 2-1   |
| 2-55       | Stick Landing Gear Hydraulic and Brake Operating Installation (Forward)            | 2-1   |
| 2-56       | Stick Landing Gear Hydraulic and Brake Operating Installation (Forward)            | 2-1   |
| 2-57       | Stick Landing Gear Hydraulic and Brake Operating Installation (Forward)            | 2-1   |
| 2-58       | Stick Landing Gear Hydraulic and Brake Operating Installation (Forward)            | 2-1   |
| 2-59       | Stick Landing Gear Hydraulic and Brake Operating Installation (Forward)            | 2-1   |
| 2-60       | Stick Landing Gear Hydraulic and Brake Operating Installation (Forward)            | 2-1   |
| 2-61       | Stick Landing Gear Hydraulic and Brake Operating Installation (Forward)            | 2-1   |
| 2-62       | Stick Landing Gear Hydraulic and Brake Operating Installation (Forward)            | 2-1   |
| 2-63       | Stick Landing Gear Hydraulic and Brake Operating Installation (Forward)            | 2-1   |
| 2-64       | Stick Landing Gear Hydraulic and Brake Operating Installation (Forward)            | 2-1   |
| 2-65       | Stick Landing Gear Hydraulic and Brake Operating Installation (Forward)            | 2-1   |
| 2-66       | Stick Landing Gear Hydraulic and Brake Operating Installation (Forward)            | 2-1   |
| 2-67       | Stick Landing Gear Hydraulic and Brake Operating Installation (Forward)            | 2-1   |
| 2-68       | Stick Landing Gear Hydraulic and Brake Operating Installation (Forward)            | 2-1   |
| 2-69       | Stick Landing Gear Hydraulic and Brake Operating Installation (Forward)            | 2-1   |
| 2-70       | Stick Landing Gear Hydraulic and Brake Operating Installation (Forward)            | 2-1   |
| 2-71       | Stick Landing Gear Hydraulic and Brake Operating Installation (Forward)            | 2-1   |
| 2-72       | Stick Landing Gear Hydraulic and Brake Operating Installation (Forward)            | 2-1   |
| 2-73       | Stick Landing Gear Hydraulic and Brake Operating Installation (Forward)            | 2-1   |
| 2-74       | Stick Landing Gear Hydraulic and Brake Operating Installation (Forward)            | 2-1   |
| 2-75       | Stick Landing Gear Hydraulic and Brake Operating Installation (Forward)            | 2-1   |
| 2-76       | Stick Landing Gear Hydraulic and Brake Operating Installation (Forward)            | 2-1   |
| 2-77       | Stick Landing Gear Hydraulic and Brake Operating Installation (Forward)            | 2-1   |
| 2-78       | Stick Landing Gear Hydraulic and Brake Operating Installation (Forward)            | 2-1   |
| 2-79       | Stick Landing Gear Hydraulic and Brake Operating Installation (Forward)            | 2-1   |
| 2-80       | Stick Landing Gear Hydraulic and Brake Operating Installation (Forward)            | 2-1   |
| 2-81       | Stick Landing Gear Hydraulic and Brake Operating Installation (Forward)            | 2-1   |
| 2-82       | Stick Landing Gear Hydraulic and Brake Operating Installation (Forward)            | 2-1   |
| 2-83       | Stick Landing Gear Hydraulic and Brake Operating Installation (Forward)            | 2-1   |
| 2-84       | Stick Landing Gear Hydraulic and Brake Operating Installation (Forward)            | 2-1   |
| 2-85       | Stick Landing Gear Hydraulic and Brake Operating Installation (Forward)            | 2-1   |
| 2-86       | Stick Landing Gear Hydraulic and Brake Operating Installation (Forward)            | 2-1   |
| 2-87       | Stick Landing Gear Hydraulic and Brake Operating Installation (Forward)            | 2-1   |
| 2-88       | Stick Landing Gear Hydraulic and Brake Operating Installation (Forward)            | 2-1   |
| 2-89       | Stick Landing Gear Hydraulic and Brake Operating Installation (Forward)            | 2-1   |
| 2-90       | Stick Landing Gear Hydraulic and Brake Operating Installation (Forward)            | 2-1   |
| 2-91       | Stick Landing Gear Hydraulic and Brake Operating Installation (Forward)            | 2-1   |
| 2-92       | Stick Landing Gear Hydraulic and Brake Operating Installation (Forward)            | 2-1   |
| 2-93       | Stick Landing Gear Hydraulic and Brake Operating Installation (Forward)            | 2-1   |
| 2-94       | Stick Landing Gear Hydraulic and Brake Operating Installation (Forward)            | 2-1   |
| 2-95       | Stick Landing Gear Hydraulic and Brake Operating Installation (Forward)            | 2-1   |
| 2-96       | Stick Landing Gear Hydraulic and Brake Operating Installation (Forward)            | 2-1   |
| 2-97       | Stick Landing Gear Hydraulic and Brake Operating Installation (Forward)            | 2-1   |
| 2-98       | Stick Landing Gear Hydraulic and Brake Operating Installation (Forward)            | 2-1   |
| 2-99       | Stick Landing Gear Hydraulic and Brake Operating Installation (Forward)            | 2-1   |
| 2-100      | Stick Landing Gear Hydraulic and Brake Operating Installation (Forward)            | 2-1   |

1. Determine in which system; fuel, oxygen, hydraulic, etc., or structure the part is located. Turn to the TABLE OF CONTENTS. From this list, select the illustration most likely to contain the desired part. Note the figure number or page number.

2. Refer to figure number or page number of the illustration selected from TABLE OF CONTENTS. Locate the desired part on the illustration. Note index number.

3. Refer to corresponding MAINTENANCE PARTS LIST. Locate the index number selected from the illustration for part number, nomenclature, etc.

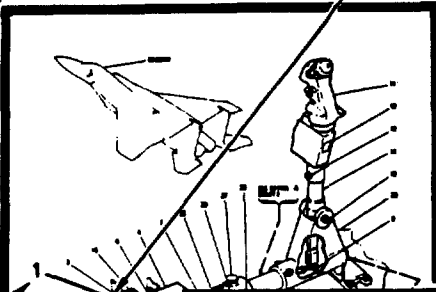

Figure 2-272

2-28-1 R15016-1

| Part No. | Description                                 | Quantity | Remarks |
|----------|---|----------|---------|
| 1        | Stick                                       | 1        |         |
| 2        | Stick Control Cable                         | 1        |         |
| 3        | Stick Control Cable Bracket                 | 1        |         |
| 4        | Stick Control Cable Bracket Pin             | 1        |         |
| 5        | Stick Control Cable Bracket Pin Washer      | 1        |         |
| 6        | Stick Control Cable Bracket Pin Nut         | 1        |         |
| 7        | Stick Control Cable Bracket Pin Lock Washer | 1        |         |
| 8        | Stick Control Cable Bracket Pin Lock Nut    | 1        |         |
| 9        | Stick Control Cable Bracket Pin Lock Washer | 1        |         |
| 10       | Stick Control Cable Bracket Pin Lock Nut    | 1        |         |

2. Locate the part on the illustration and note the index number.

3. Refer to corresponding MAINTENANCE PARTS LIST. Locate the index number selected from the illustration for part number, nomenclature, etc.

1. If applicable determine in which system; fuel oxygen, hydraulic, controls, etc., the part is located. Turn to the COMPLETE SYSTEM INDEX DRAWING which appears as the last page. Select the part in question or a part in the area in question of the appropriate SYSTEM INDEX DRAWING. Note figure number.

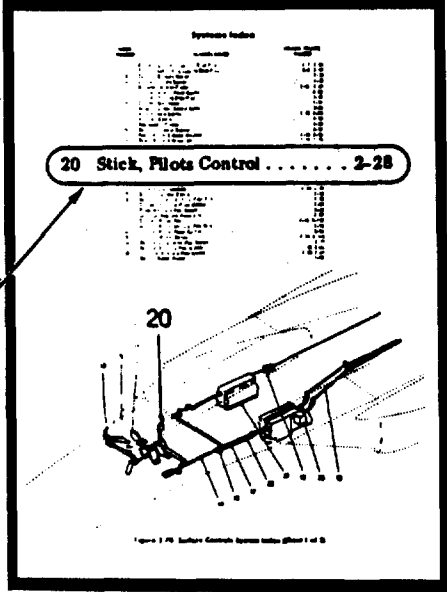

**Do This** TO LOCATE THE PART BY SYSTEM INDEX DRAWING

HOW TO USE THE ILLUSTRATED PARTS BREAKDOWN-Continued

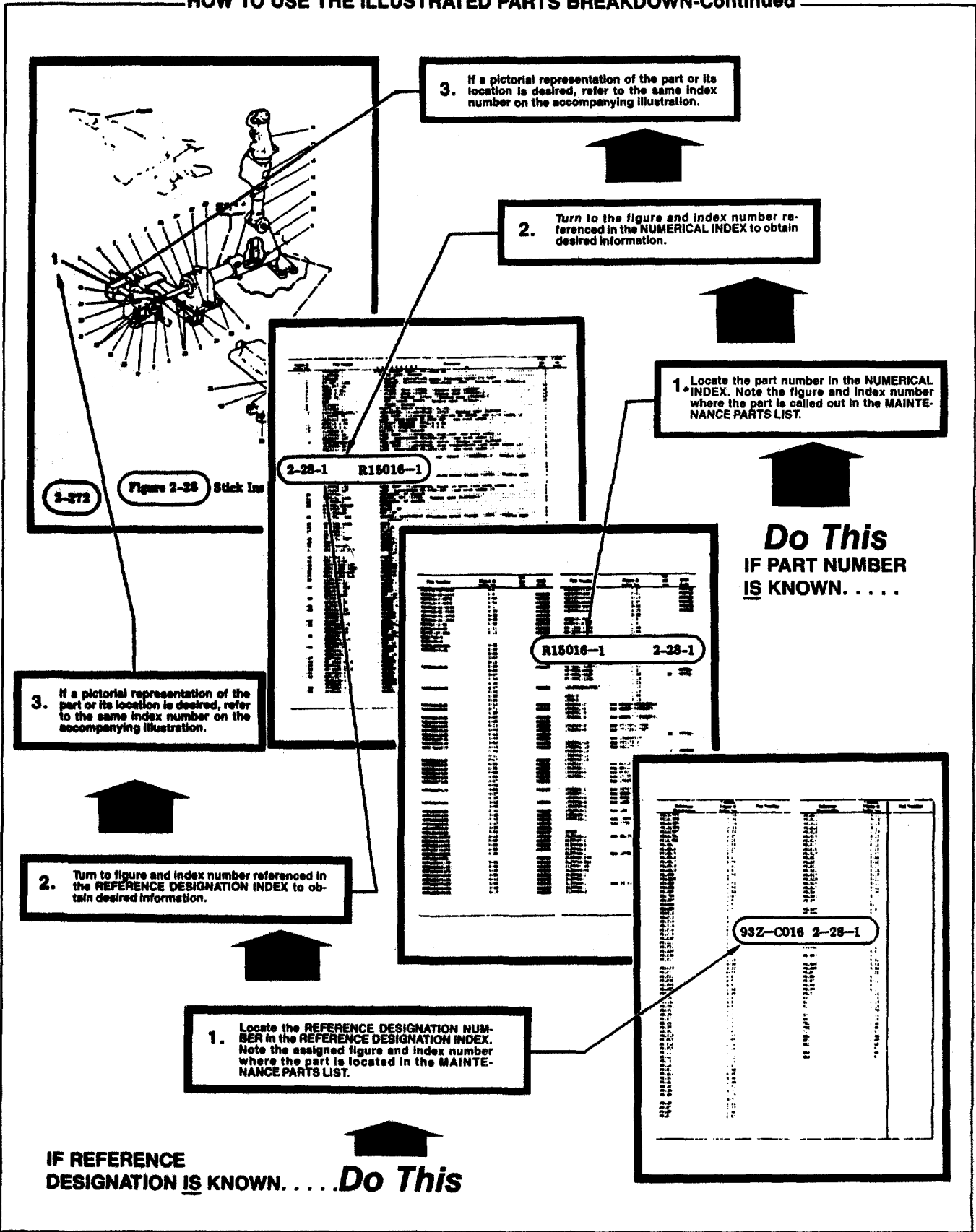

Section II. MAINTENANCE PARTS LIST

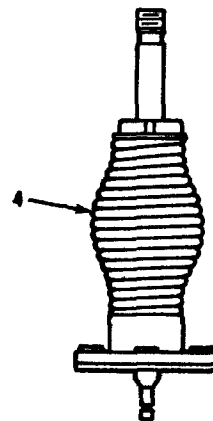
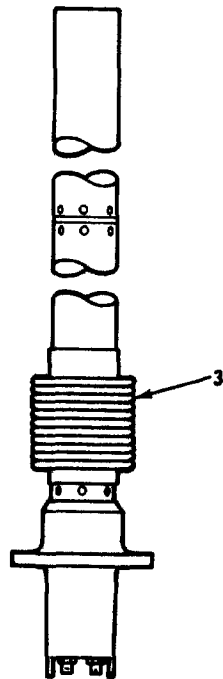
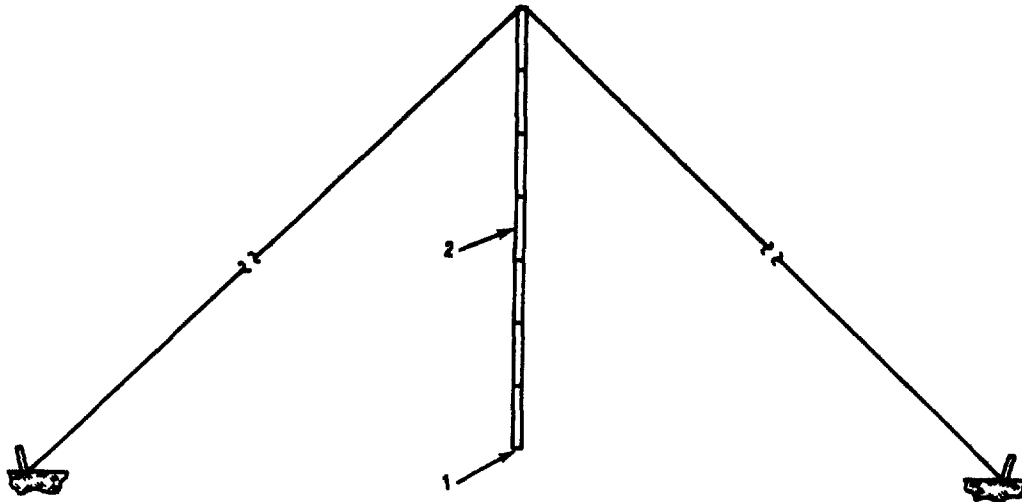

MX-61-11B-1PB-1-1  
REF MAG DWG 707167 REV B  
PL 707167 REV AD

FIGURE 7-1. RADIO COMMUNICATION SYSTEM AN/QRС-206(V)1, AN/206(V)2 (SHEET 1 OF 6)

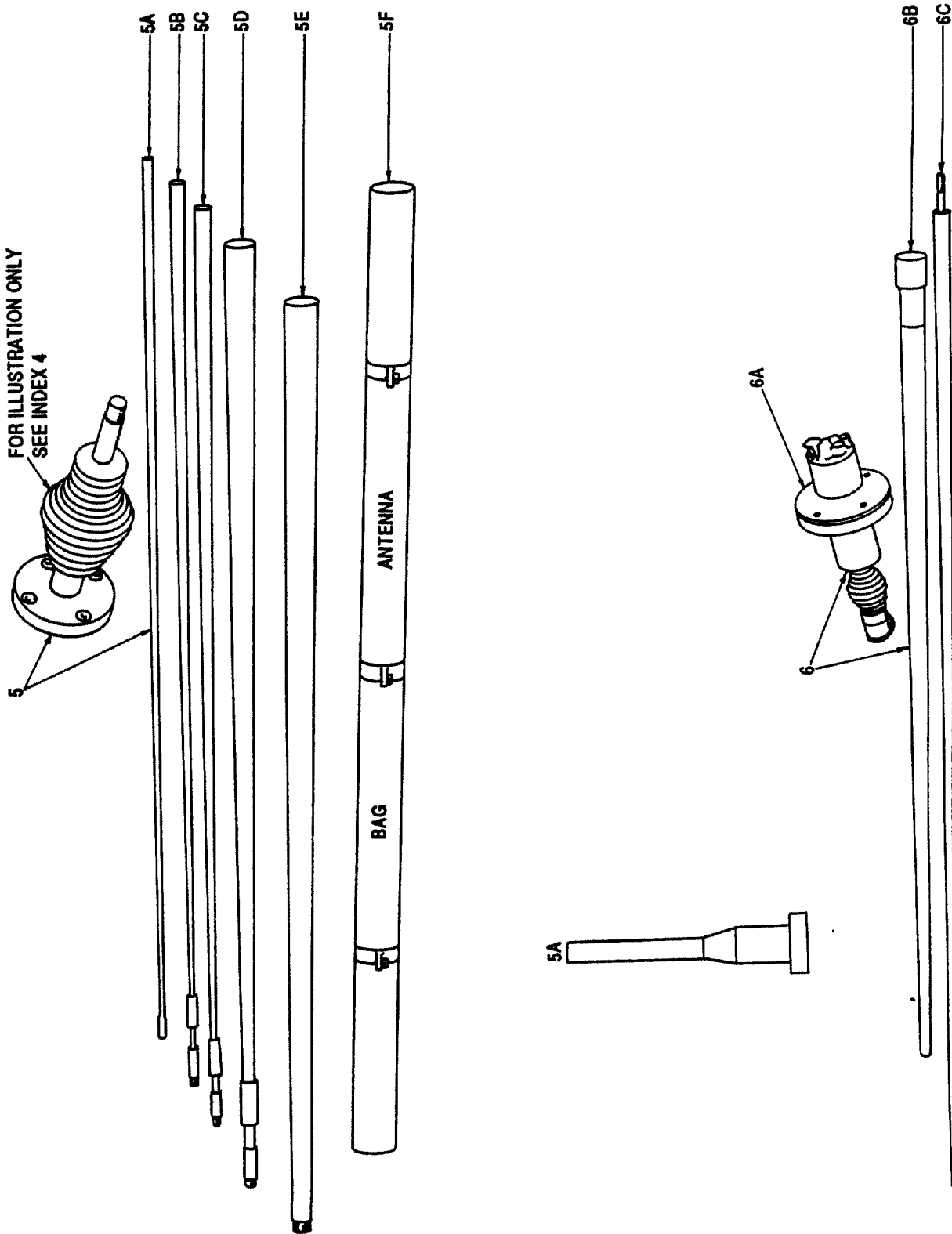

FIGURE 7-1. RADIO COMMUNICATION SYSTEM AN/GRC-206(V)1, AN/206(V)2 (SHEET 2 OF 6)

MX-61-119-1PB-1-3

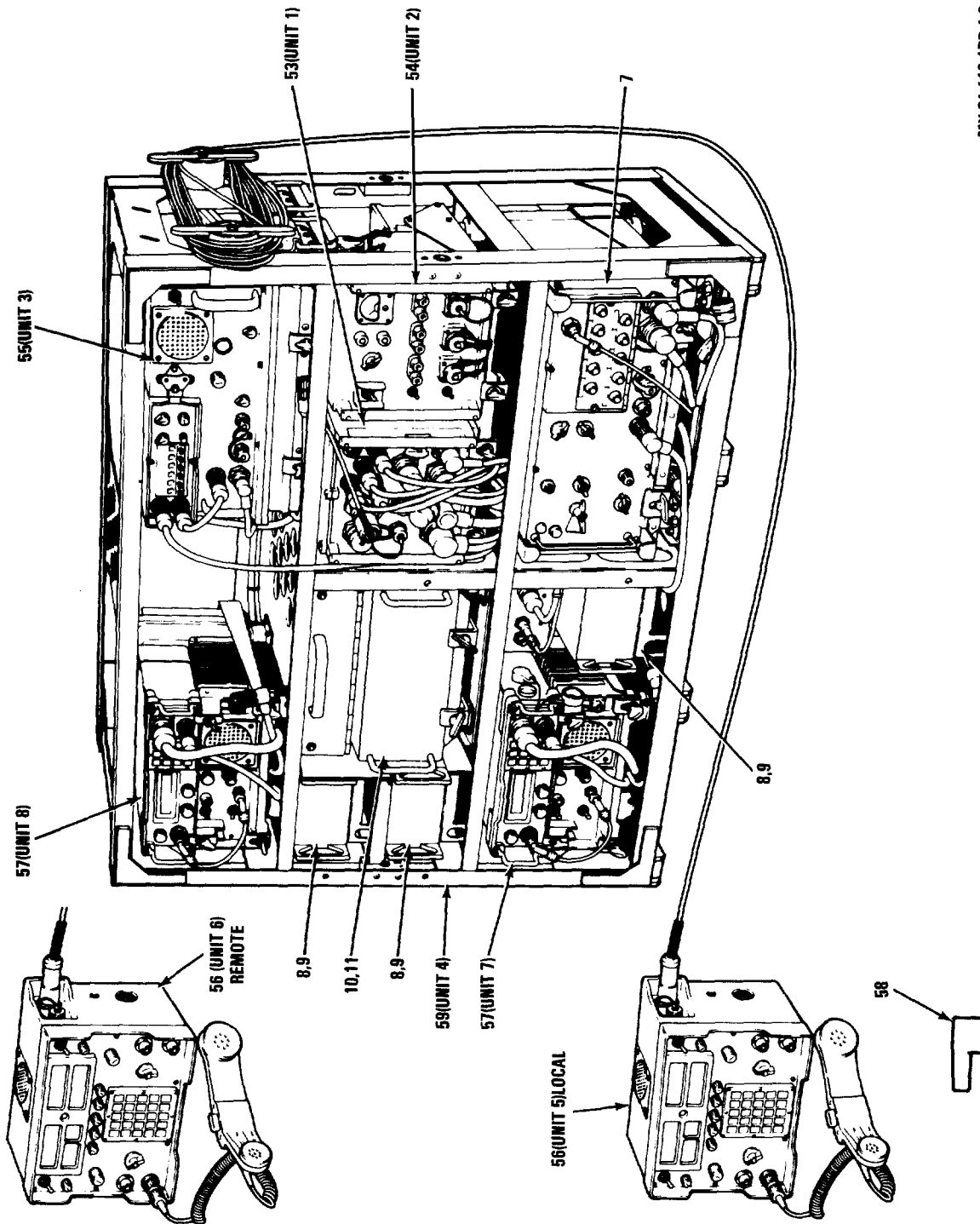
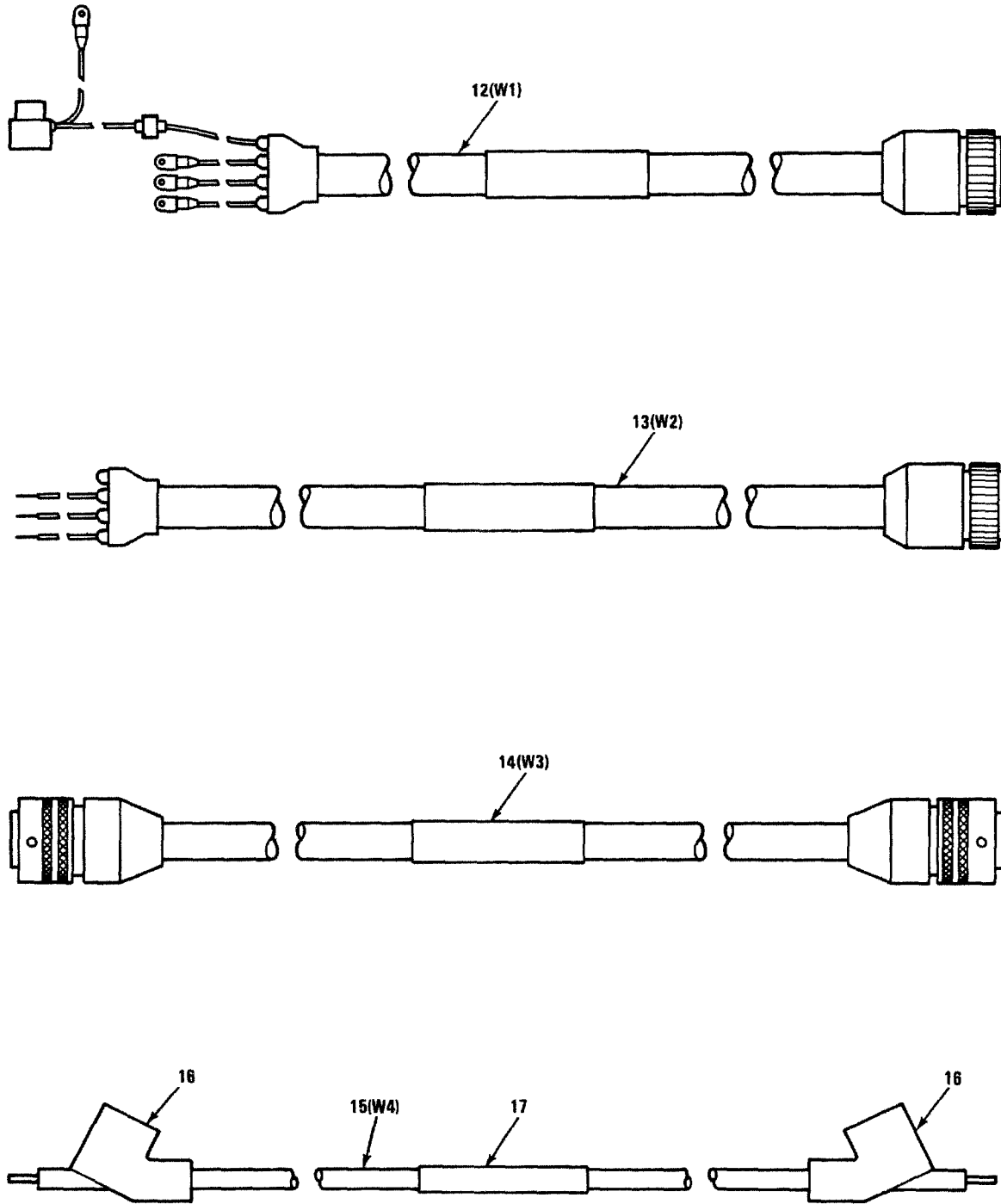

FIGURE 7-1. RADIO COMMUNICATION SYSTEM AN/0RC-206(V)1, AN/206(V)2 (SHEET 3 OF 6)

FIGURE 7-1. RADIO COMMUNICATION SYSTEM AN/0RC-206(V)1, AN/206(V)2 (SHEET 3 OF 6)



MX-61-119-1PB-14

FIGURE 7-1. RADIO COMMUNICATION SYSTEM AN/0RC-206(V)1, AN/206(V)2 (SHEET 4 OF 6)

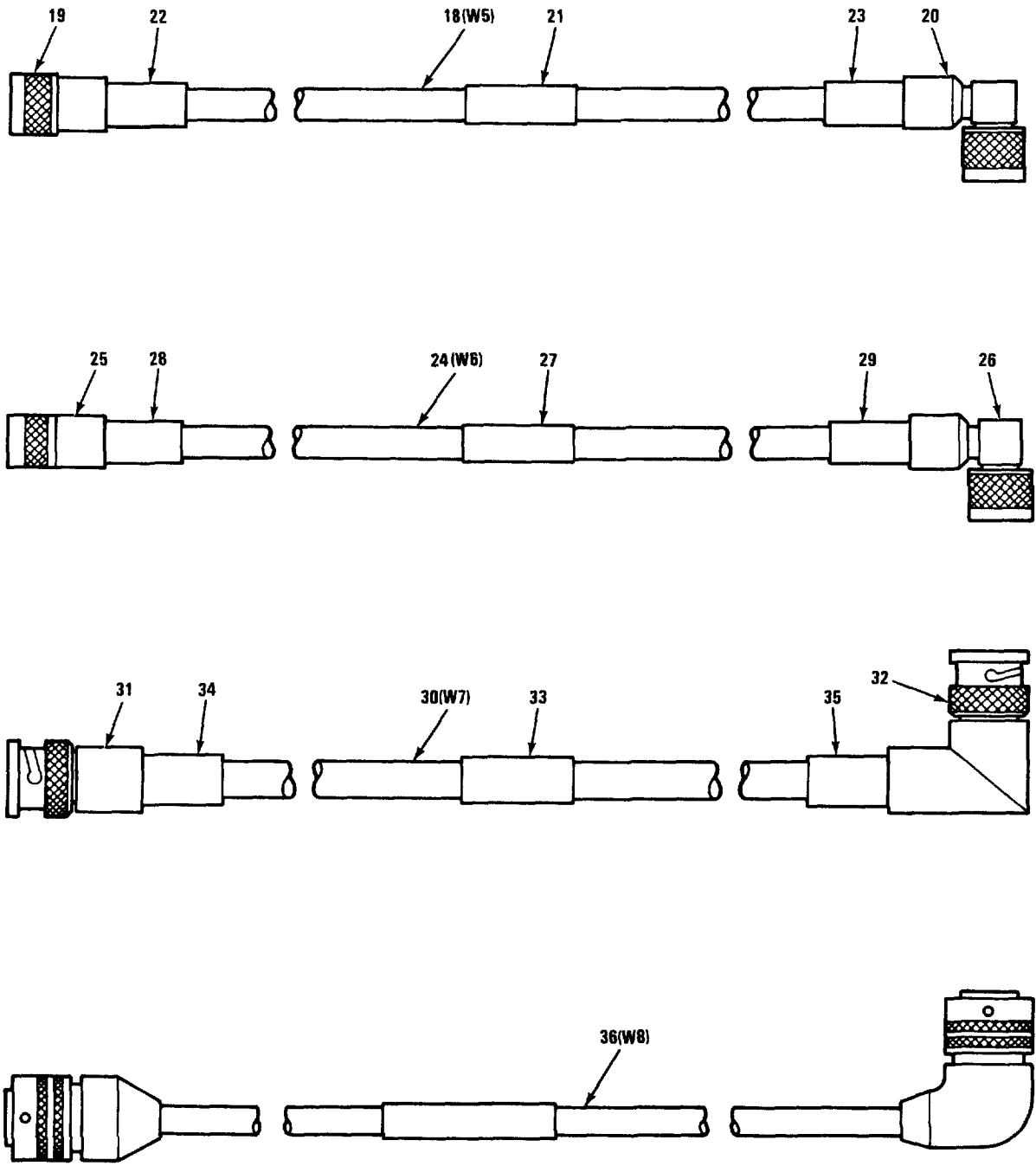

MX-61-119-1PB-15

FIGURE 7-1. RADIO COMMUNICATION SYSTEM AN/ARC-206(V)1, AN/206(V)2 (SHEET 5 OF 6)

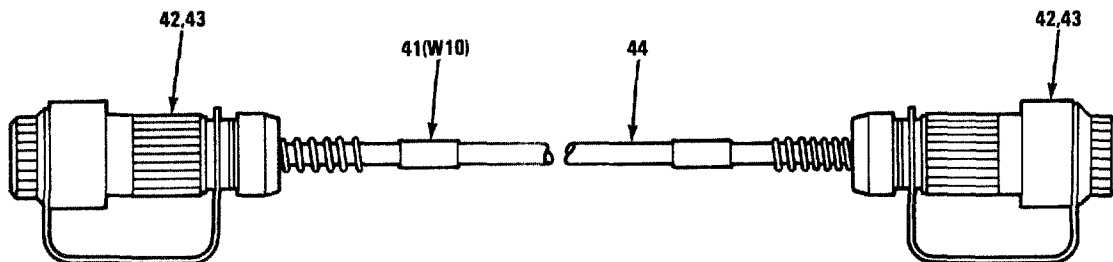
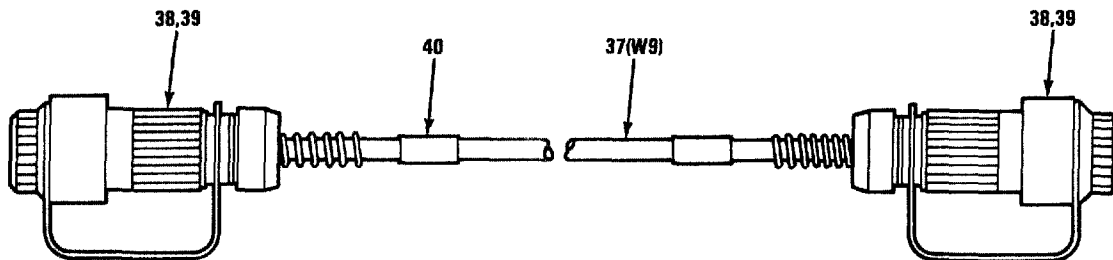
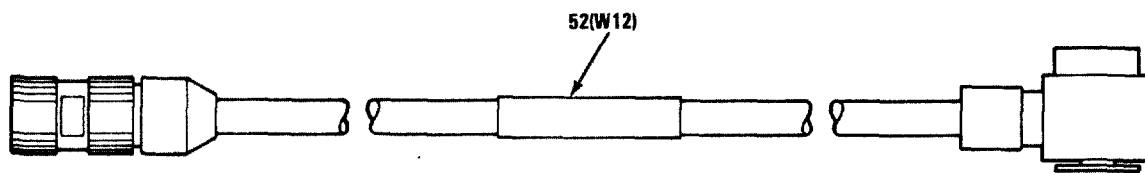
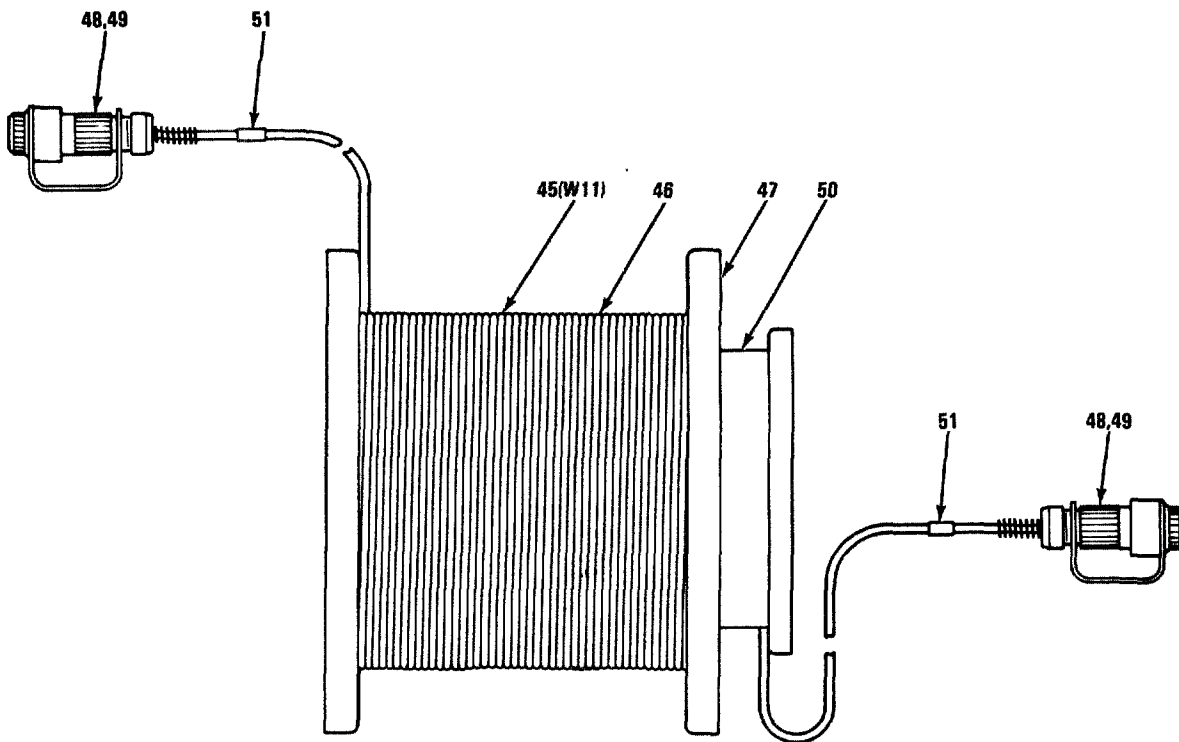

MX-61-119-1PB-1-6

FIGURE 7-1. RADIO COMMUNICATION SYSTEM AN/GR-206(V)1, AN/206(V)2 (SHEET 6 OF 6)



| FIG. &<br>INDEX<br>NUMBER | PART NUMBER     | FSCM  | DESCRIPTION                                 |   |   |   |   |   |   | UNITS<br>PER<br>ASSY | USABLE<br>ON<br>CODE | SMR<br>CODE |
|---------------------------|-----------------|-------|---|---|---|---|---|---|---|----------------------|----------------------|-------------|
|                           |                 |       | 1   | 2 | 3 | 4 | 5 | 6 | 7 |                      |                      |             |
| 7-1-                      | 707167-801      | 37695 | COMMUNICATION SYSTEM, RADIO, AN/GRC-206(V)1 |   |   |   |   |   |   | 1                    | A                    | PAODD       |
|                           | 707167-802      | 37695 | COMMUNICATION SYSTEM, RADIO, AN/GRC-206(V)2 |   |   |   |   |   |   | 1                    | B                    | PAODD       |
| -1                        | MX9313/GR       | 80058 | . ADAPTER, ANT TO ANT BASE                  |   |   |   |   |   |   | 1                    |                      | PAOFF       |
| -2                        | 758-5377-001    | 13499 | . HF (NVIS) ANTENNA                         |   |   |   |   |   |   | 1                    |                      | PAOFF       |
| -3                        | AS-3588/GRC-206 | 80058 | . ANTENNA, VHF/UHF                          |   |   |   |   |   |   | 1                    |                      | PAODD       |
| -4                        | 4245-1          | 23657 | . BASE ASSEMBLY, HF ANTENNA                 |   |   |   |   |   |   | 1                    |                      | PBOZZ       |
| -5                        | 553-6725-000    | 13499 | . ANTENNA KIT (GFE)                         |   |   |   |   |   |   | 1                    |                      | PAOZZ       |
| -5A                       | AT-1039/U       | 80058 | . . ANTENNA ELEMENT                         |   |   |   |   |   |   | 1                    |                      | PAOZZ       |
| -5B                       | AT-1040/U       | 80058 | . . ANTENNA ELEMENT                         |   |   |   |   |   |   | 1                    |                      | PAOZZ       |
| -5C                       | AT-1041/U       | 80058 | . . ANTENNA ELEMENT                         |   |   |   |   |   |   | 1                    |                      | PAOZZ       |
| -5D                       | AT-1042/U       | 80058 | . . ANTENNA ELEMENT                         |   |   |   |   |   |   | 1                    |                      | PAOZZ       |
| -5E                       | AT-1043/U       | 80058 | . . ANTENNA ELEMENT                         |   |   |   |   |   |   | 4                    |                      | PAOZZ       |
| -5F                       | 348657-1        | 37695 | . . INSULATION BOOT                         |   |   |   |   |   |   | 1                    |                      | PAOZZ       |
| -5G                       | 546-7935-004    | 13499 | . . . BAG, ANTENNA                          |   |   |   |   |   |   | 1                    |                      | PAOZZ       |
| -6                        | AS-1729/VRC     | 80050 | . ANTENNA, VHF/FM (GFE)                     |   |   |   |   |   |   | 1                    |                      | PAOZZ       |
| -6A                       | MX6707/VRC      | 80058 | . . MACHING UNIT-B                          |   |   |   |   |   |   | 1                    |                      | PAOZZ       |
| -6B                       | AS1730/VRC      | 80058 | . . ANTENNA ELEMENT                         |   |   |   |   |   |   | 1                    |                      | PAOZZ       |
| -6C                       | AT-1095A/VRC    | 80058 | . . ANTENNA ELEMENT                         |   |   |   |   |   |   | 1                    |                      | PAOZZ       |
|                           | SSC446180       | 80063 | . . . ANTENNA TIP                           |   |   |   |   |   |   | 1                    |                      | PAOZZ       |
|                           | PLL3687         | 80063 | . . . ROPE, Fiber                           |   |   |   |   |   |   | 1                    |                      | PAOZZ       |
| -7                        | RT-246/VRC      | 80058 | . RECEIVER-XMTR (GFE)                       |   |   |   |   |   |   | 1                    |                      | PAOZZ       |
|                           | RT-524/VRC      | 80058 | . RECEIVER-XMTR (GFE)                       |   |   |   |   |   |   | 1                    |                      | PAOLD       |
| -8                        | TSEC/KY57       | 98230 | . SPEECH SECURITY EQUIPMENT (GFE)           |   |   |   |   |   |   | 3                    |                      | PAOLD       |
| -9                        | HYP-57/TSEC     | 98230 | . POWER SUPPLY, VEHICLE (GFE)               |   |   |   |   |   |   | 3                    |                      | PAOLD       |
| -10                       | TSEC/KY65       | 98230 | . SPEECH SECURITY EQUIPMENT (GFE)           |   |   |   |   |   |   | 1                    |                      | PAOLD       |
| -11                       | Z-AKF/TSEC      | 98230 | . POWER SUPPLY, VEHICLE (GFE)               |   |   |   |   |   |   | 1                    |                      | PAOLD       |
| -12                       | 566073-801      | 37695 | . CABLE ASSEMBLY, INPUT POWER               |   |   |   |   |   |   | 1                    |                      | PBOZZ       |
| -13                       | 566073-802      | 37695 | . CABLE ASSEMBLY, INPUT POWER               |   |   |   |   |   |   | 1                    |                      | PBOZZ       |
| -14                       | 566085-807      | 37695 | . CABLE ASSEMBLY, URSC POWER                |   |   |   |   |   |   | 2                    |                      | PBOZZ       |
| -15                       | 566076-801      | 37695 | . CABLE ASSEMBLY, HF ANTENNA                |   |   |   |   |   |   | 1                    |                      | MFF         |
| -16                       | 348499-1        | 37695 | . . BOOT, RUBBER                            |   |   |   |   |   |   | 2                    |                      | PAFZZ       |
| -17                       | 155931-4        | 37695 | . . BAND MARKER                             |   |   |   |   |   |   | 1                    |                      | XB          |
| -18                       | 566077-801      | 37695 | . CABLE ASSEMBLY, VHF/UHF ANTENNA           |   |   |   |   |   |   | 1                    |                      | MFF         |
| -19                       | M39012/01-0005  | 81349 | . . CONNECTOR                               |   |   |   |   |   |   | 1                    |                      | PAFZZ       |
| -20                       | M39012/05-0101  | 81349 | . . CONNECTOR                               |   |   |   |   |   |   | 1                    |                      | PAFZZ       |
| -21                       | 155931-5        | 37695 | . . BAND MARKER                             |   |   |   |   |   |   | 1                    |                      | XB          |
| -22                       | 155931-16       | 37695 | . . BAND MARKER                             |   |   |   |   |   |   | 1                    |                      | XB          |
| -23                       | 155931-15       | 37695 | . . BAND MARKER                             |   |   |   |   |   |   | 1                    |                      | XB          |
| -24                       | 566077-802      | 37695 | . CABLE ASSEMBLY, VHF/UHF ANTENNA           |   |   |   |   |   |   | 1                    |                      | MFF         |
| -25                       | M39012/06-0002  | 81349 | . . CONNECTOR                               |   |   |   |   |   |   | 1                    |                      | PAFZZ       |
| -26                       | M39012/05-0101  | 81349 | . . CONNECTOR                               |   |   |   |   |   |   | 1                    |                      | PAFZZ       |
| -27                       | 155931-6        | 37695 | . . BAND MARKER                             |   |   |   |   |   |   | 1                    |                      | XB          |
| -28                       | 155931-18       | 37695 | . . BAND MARKER                             |   |   |   |   |   |   | 1                    |                      | XB          |
| -29                       | 155931-17       | 37695 | . . BAND MARKER                             |   |   |   |   |   |   | 1                    |                      | XB          |
| -30                       | 566078-801      | 37695 | . CABLE ASSEMBLY, VHF/FM ANTENNA            |   |   |   |   |   |   | 1                    |                      | MFF         |
| -31                       | M39012/16-0101  | 81349 | . . CONNECTOR                               |   |   |   |   |   |   | 1                    |                      | PAFZZ       |
| -32                       | M39012/20-0101  | 81349 | . . CONNECTOR                               |   |   |   |   |   |   | 1                    |                      | PAFZZ       |
| -33                       | 155931-7        | 37695 | . . BAND MARKER                             |   |   |   |   |   |   | 1                    |                      | XB          |
| -34                       | 155931-13       | 37695 | . . BAND MARKER                             |   |   |   |   |   |   | 1                    |                      | XB          |

| FIG. &<br>INDEX<br>NO. | PART NUMBER               | FSCM  | 1234567 | DESCRIPTION                            | UNITS<br>PER<br>ASSY | USABLE<br>ON<br>CODE | SMR<br>CODE |
|------------------------|---------------------------|-------|---------|--|----------------------|----------------------|-------------|
| 7-1-                   |                           |       |         |  |                      |                      |             |
| -35                    | 155931-14                 | 37695 | .       | BAND MARKER.....                       | 1                    |                      | XB          |
| -36                    | 566083-806                | 37695 | .       | CABLE ASSEMBLY, FM ANTENNA.....        | 1                    |                      | PBOZZ       |
|                        |                           |       |         | CONTROL                                |                      |                      |             |
| -37                    | 566084-807                | 37695 | .       | CABLE ASSEMBLY, VIC-1 AUDIO.....       | 1                    |                      | PBOZZ       |
|                        | D02-048C-A3FB/<br>900-MIL | 6Y528 | .       | CABLE, FIBER OPTIC.....                | AR                   |                      | XB          |
|                        |                           |       |         | P/N 626703-1(37695)                    |                      |                      |             |
| -38                    | FOMC6-2W2A-001            | 92708 | .       | CONNECTOR, FIBER OPTIC.....            | 2                    |                      | PADZZ       |
|                        |                           |       |         | (MAGNAVOX SPEC CONT DWG<br>626498-106) |                      |                      |             |
| -39                    | +FOMC-T-05-1219           | 92708 | .       | CONNECTOR, FIBER OPTIC.....            | 4                    |                      | PADZZ       |
|                        |                           |       |         | (MAGNAVOX SPEC CONT DWG<br>626498-311) |                      |                      |             |
|                        | +FOMC-T-05-1245           | 92708 | .       | CONNECTOR, FIBER OPTIC.....            | 4                    |                      | PADZZ       |
|                        |                           |       |         | (MAGNAVOX SPEC CONT DWG<br>626498-312) |                      |                      |             |
|                        | +FOMC-T-05-1270           | 92708 | .       | CONNECTOR, FIBER OPTIC.....            | 4                    |                      | PADZZ       |
|                        |                           |       |         | (MAGNAVOX SPEC CONT DWG<br>626498-313) |                      |                      |             |
|                        | +FOMC-T-05-1295           | 92708 | .       | CONNECTOR, FIBER OPTIC.....            | 4                    |                      | PADZZ       |
|                        |                           |       |         | (MAGNAVOX SPEC CONT DWG<br>626498-314) |                      |                      |             |
| -40                    | 155931-2                  | 37695 | .       | BAND MARKER.....                       | 2                    |                      | XB          |
| -41                    | 566080-801                | 37695 | .       | CABLE ASSEMBLY, FIBER OPTIC.....       | 1                    |                      | PAODD       |
|                        | D02-048C-A3FB/<br>900-MIL | 6Y528 | .       | CABLE, FIBER OPTIC.....                | AR                   |                      | PAODD       |
|                        |                           |       |         | P/N 626703-1(37695)                    |                      |                      |             |
| -42                    | FOMC6-2W2A-001            | 92708 | .       | CONNECTOR, FIBER OPTIC.....            | 2                    |                      | PADZZ       |
|                        |                           |       |         | (MAGNAVOX SPEC CONT DWG<br>626498-106) |                      |                      |             |
| -43                    | +FOMC-T-05-1219           | 92708 | .       | CONNECTOR, FIBER OPTIC.....            | 4                    |                      | PADZZ       |
|                        |                           |       |         | (MAGNAVOX SPEC CONT DWG<br>626498-311) |                      |                      |             |
|                        | +FOMC-T-05-1245           | 92708 | .       | CONNECTOR, FIBER OPTIC.....            | 4                    |                      | PADZZ       |
|                        |                           |       |         | (MAGNAVOX SPEC CONT DWG 626498-312)    |                      |                      |             |
|                        | +FOMC-T-05-1270           | 92708 | .       | CONNECTOR, FIBER OPTIC.....            | 4                    |                      | PADZZ       |
|                        |                           |       |         | (MAGNAVOX SPEC CONT DWG 626498-313)    |                      |                      |             |
|                        | +FOMC-T-05-1295           | 92708 | .       | CONNECTOR, FIBER OPTIC.....            | 4                    |                      | PADZZ       |
|                        |                           |       |         | (MAGNAVOX SPEC CONT DWG 626498-314)    |                      |                      |             |
| -44                    | 155931-1                  | 37695 | .       | BAND MARKER.....                       | 2                    |                      | XB          |
| -45                    | 566081-801                | 37695 | .       | CABLE ASSEMBLY, FIBER OPTIC, .....     | 2                    |                      | PAODD       |
|                        |                           |       |         | 1 KILOMETER                            |                      |                      |             |
| -46                    | 812908-801                | 37695 | .       | CABLE ASSEMBLY, FIBER OPTIC, W/O..     | 1                    |                      | PADLD       |
|                        |                           |       |         | CONNECTORS                             |                      |                      |             |
|                        | D02-048C-A3FB/<br>900-MIL | 6Y528 | .       | CABLE, FIBER OPTIC.....                | AR                   |                      | XB          |
|                        |                           |       |         | P/N 626703-1 (37695)                   |                      |                      |             |
| -47                    | 348494-1                  | 37695 | .       | REEL, CABLE.....                       | 1                    |                      | PBOZZ       |
| -48                    | FOMC6-2W2A-001            | 92708 | .       | CONNECTOR, FIBER OPTIC.....            | 2                    |                      | PADZZ       |
|                        |                           |       |         | (MAGNAVOX SPEC CONT DWG 626498-106)    |                      |                      |             |
| -49                    | +FOMC-T-05-1219           | 92708 | .       | CONNECTOR, FIBER OPTIC.....            | 4                    |                      | PADZZ       |
|                        |                           |       |         | (MAGNAVOX SPEC CONT DWG 626498-311)    |                      |                      |             |
|                        | +FOMC-T-05-1245           | 92708 | .       | CONNECTOR, FIBER OPTIC.....            | 4                    |                      | PADZZ       |
|                        |                           |       |         | (MAGNAVOX SPEC CONT DWG 626498-312)    |                      |                      |             |
|                        | +FOMC-T-05-1270           | 92708 | .       | CONNECTOR, FIBER OPTIC.....            | 4                    |                      | PADZZ       |

| FIG. &<br>INDEX<br>NO. | PART NUMBER     | FSCM  | 1234567 | DESCRIPTION  | UNITS<br>PER<br>ASSY | USABLE<br>ON<br>CODE | SMR<br>CODE |
|------------------------|-----------------|-------|---------|--|----------------------|----------------------|-------------|
| 7-1-                   |                 |       |         | (MAGNAVOX SPEC CONT DWG 626498-313)                      |                      |                      |             |
|                        | +FOMC-T-05-1295 | 92708 |         | . . CONNECTOR, FIBER OPTIC.....                          | 4                    |                      | PADZZ       |
|                        |                 |       |         | (MAGNAVOX SPEC CONT DWG 626498-314)                      |                      |                      |             |
| -50                    | 405018-2        | 37695 |         | . . STRAP, STOWAGE.....                                  | 1                    |                      | XB          |
| -51                    | 155931-3        | 37695 |         | . . BAND MARKER.....                                     | 2                    |                      | XB          |
| -53                    | 812081-801      | 37695 |         | . CONTROL, SIGNAL DISTRIBUTION.....                      | 1                    |                      | PAODD       |
|                        |                 |       |         | UNIT C-11169/GRC-206 (SEE FIGURE<br>7-2 FOR BKDN)        |                      |                      |             |
| -54                    | 812082-801      | 37695 |         | . SWITCHBOARD, POWER.....                                | 1                    |                      | PAODD       |
|                        |                 |       |         | SB-4151/GRC-206 (SEE FIGURE<br>7-13 FOR BKDN)            |                      |                      |             |
| -55                    | 812083-801      | 37695 |         | . RADIO SET, AN/URC-113.....                             | 1                    |                      | PAODD       |
|                        |                 |       |         | (SEE FIGURE 7-16 FOR BKDN)                               |                      |                      |             |
| -56                    | 812085-801      | 37695 |         | . CONTROL, RADIO SET.....                                | 2                    |                      | PAODD       |
|                        |                 |       |         | C-11166/GRC-206 (SEE FIGURE 7-17<br>FOR BKDN)            |                      |                      |             |
| -57                    | 707123-802#     | 37695 |         | . RADIO SET, AN/VRC-83 (V)2.....                         | 2                    |                      | PAODD       |
| -58                    | 348657-1        | 37695 |         | . BOOT, INSULATOR.....                                   | 1                    |                      | PAFZZ       |
| -59                    | 812084-801      | 37695 |         | . MOUNTING BASE, ELECTRICAL.....                         | 1                    | A                    | XB          |
|                        |                 |       |         | EQUIPMENT MT-6250/GRC-206 (SEE<br>FIGURE 7-24 FOR BKDN)  |                      |                      |             |
|                        | 812084-802      | 37695 |         | . MOUNTING BASE, ELECTRICAL.....                         | 1                    | B                    | XB          |
|                        |                 |       |         | EQUIPMENT MT-6250A/GRC-206 (SEE<br>FIGURE 7-24 FOR BKDN) |                      |                      |             |

A-USED ON 707167-801 ONLY  
B-USED ON 707167-802 ONLY



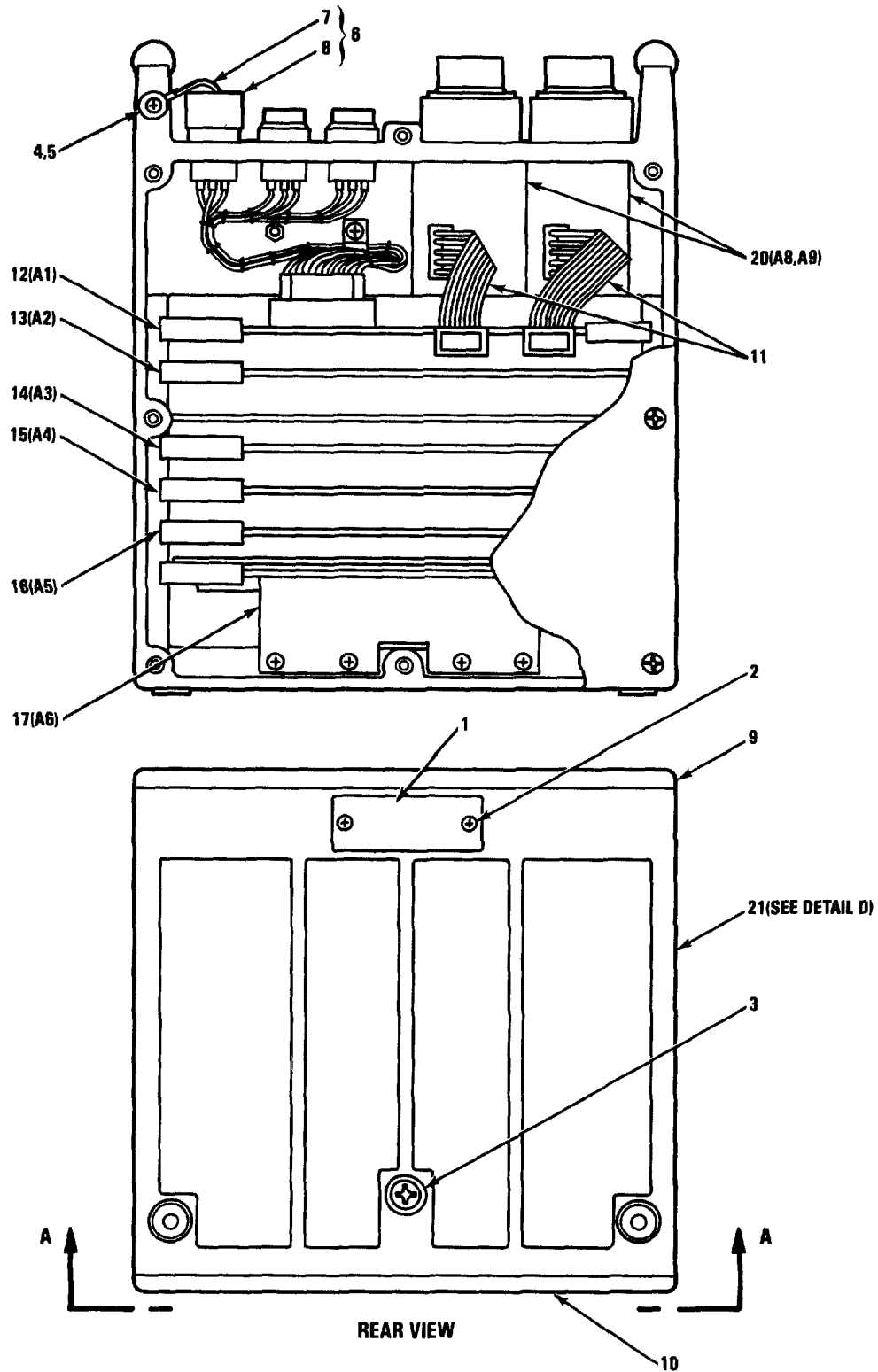

NOTE: REFERENCE DESIGNATIONS ARE ABBREVIATED.  
PREFIX WITH 1.

MX-61-119-IPB-2-1  
REF MAG DWG 812081 REV D  
PL 812081 REV L

FIGURE 7-2. CONTROL SIGNAL DISTRIBUTION UNIT, C-11169/0RC-206 (SHEET 1 OF 2)

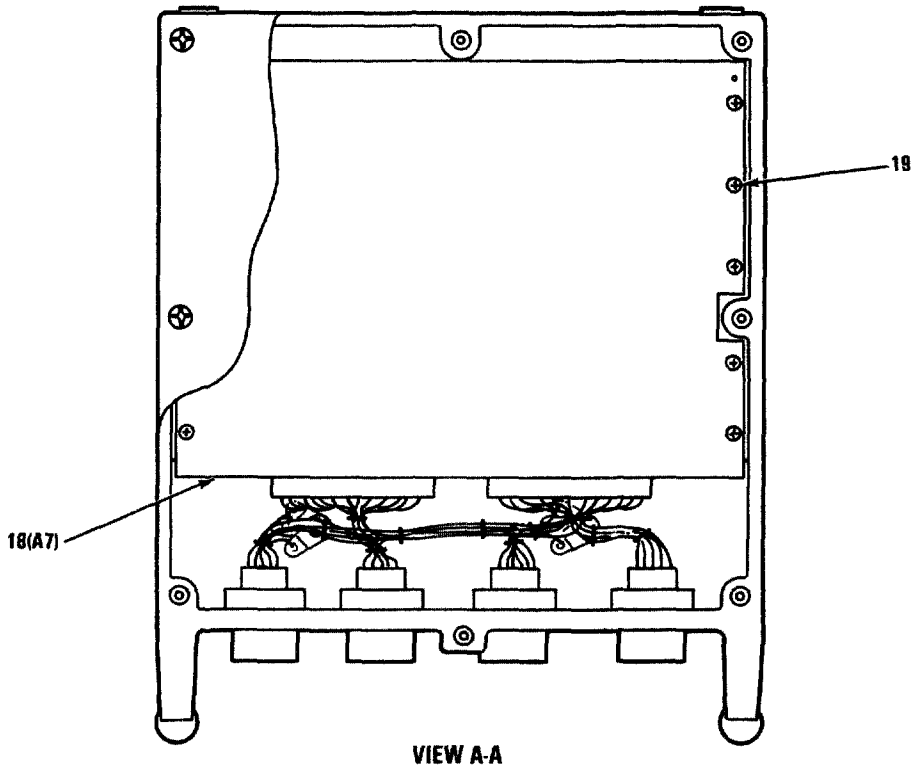

NOTE: REFERENCE DESIGNATIONS ARE ABBREVIATED.  
PREFIX WITH 1.

MX-61-119-IP8-2-2

FIGURE 7-2. CONTROL SIGNAL DISTRIBUTION UNIT, C-11169/QRC-206 (SHEET 2 OF 2)

| FIG. &<br>INDEX<br>NUMBER | PART NUMBER  | FSCM  | DESCRIPTION   |   |   |   |   |   |   | UNITS<br>PER<br>ASSY | USABLE<br>ON<br>CODE | SMR<br>CODE |
|---------------------------|--------------|-------|---|---|---|---|---|---|---|----------------------|----------------------|-------------|
|                           |              |       | 1   | 2 | 3 | 4 | 5 | 6 | 7 |                      |                      |             |
| 7-2-                      | 812081-801   | 37695 | CONTROL SIGNAL DISTRIBUTION UNIT, . . . . .<br>C-11169/GRC-206 (SEE FIGURE 7-1 FOR NHA) |   |   |   |   |   |   | REF                  |                      | PAODD       |
| -1                        | 155896-*     | 37695 | . PLATE, IDENTIFICATION . . . . .   |   |   |   |   |   |   | 1                    |                      | MDD         |
| -2                        | MS51957-11   | 96906 | . SCREW (AP). . . . .   |   |   |   |   |   |   | 2                    |                      | PAFZZ       |
| -3                        | MS3213-31    | 96906 | . SCREW . . . . .   |   |   |   |   |   |   | 1                    |                      | PAFZZ       |
| -4                        | 514919-1     | 37695 | . BUSHING . . . . .   |   |   |   |   |   |   | 1                    |                      | PAFZZ       |
| -5                        | MS51957-14B  | 96906 | . SCREW . . . . .   |   |   |   |   |   |   | 1                    |                      | PAFZZ       |
|                           | MS35338-135B | 96906 | . WASHER . . . . .  |   |   |   |   |   |   | 1                    |                      | PAFZZ       |
| -6                        | 812187-802   | 37695 | . CAP ASSEMBLY, CONNECTOR . . . . .   |   |   |   |   |   |   | 1                    |                      | XB          |
| -7                        | 938573-1     | 37695 | . . FERRULE . . . . .   |   |   |   |   |   |   | 2                    |                      | PAOZZ       |
| -8                        | 348205-2     | 37695 | . . CAP, PROTECTIVE . . . . .   |   |   |   |   |   |   | 1                    |                      | PAOZZ       |
| -9                        | 660152-801   | 37695 | . COVER, DISTRIBUTION UNIT . . . . .<br>(SEE FIGURE 7-3 FOR BKDN)                       |   |   |   |   |   |   | 1                    |                      | XB          |
| -10                       | 660152-803   | 37695 | . COVER, DISTRIBUTION UNIT . . . . .<br>(SEE FIGURE 7-3 FOR BKDN)                       |   |   |   |   |   |   | 1                    |                      | XB          |
| -11                       | 566588-801   | 37695 | . CABLE ASSEMBLY, ELECTRIC POWER . . . . .  |   |   |   |   |   |   | 2                    |                      | PAFZZ       |
| -12                       | 812094-801   | 37695 | . CIRCUIT CARD ASSEMBLY, AUDIO . . . . .<br>INTERFACE (1) (SEE FIGURE 7-4 FOR BKDN)     |   |   |   |   |   |   | 1                    |                      | PAFLD       |
| -13                       | 812095-801   | 37695 | . CIRCUIT CARD ASSEMBLY, AUDIO . . . . .<br>INTERFACE (2) (SEE FIGURE 7-5 FOR BKDN)     |   |   |   |   |   |   | 1                    |                      | PAFLD       |
| -14                       | 812154-801   | 37695 | . CIRCUIT CARD ASSEMBLY, RED INTERFACE . . . . .<br>(SEE FIGURE 7-6 FOR BKDN)           |   |   |   |   |   |   | 1                    |                      | PAFLD       |
| -15                       | 812117-801   | 37695 | . CIRCUIT CARD ASSEMBLY, BLACK INTERFACE . . . . .<br>(SEE FIGURE 7-7 FOR BKDN)         |   |   |   |   |   |   | 1                    |                      | PAFLD       |
| -16                       | 812116-801   | 37695 | . CIRCUIT CARD ASSEMBLY, CPU . . . . .<br>(SEE FIGURE 7-8 FOR BKDN)                     |   |   |   |   |   |   | 1                    |                      | PAFLD       |
| -17                       | 812122-801   | 37695 | . POWER SUPPLY SUBASSEMBLY . . . . .<br>(SEE FIGURE 7-9 FOR BKDN)                       |   |   |   |   |   |   | 1                    |                      | PADLD       |
| -18                       | 812129-801   | 37695 | . BACKPLANE ASSEMBLY (SEE FIGURE 7-10 . . . . .<br>FOR BKDN)                            |   |   |   |   |   |   | 1                    |                      | XB          |
| -19                       | MS51957-15   | 96906 | . SCREW (AP). . . . .   |   |   |   |   |   |   | 10                   |                      | PAFZZ       |
|                           | NAS620C4     | 80205 | . WASHER (AP) . . . . .   |   |   |   |   |   |   | 10                   |                      | PAFZZ       |
|                           | MS35338-135  | 96906 | . WASHER (AP) . . . . .   |   |   |   |   |   |   | 10                   |                      | PAFZZ       |
| -20                       | 812099-801   | 37695 | . MODULE ASSEMBLY, FIBER OPTIC . . . . .<br>(SEE FIGURE 7-11 FOR BKDN)                  |   |   |   |   |   |   | 2                    |                      | PAFLD       |
| -21                       | 812086-801   | 37695 | . CHASSIS, ELECTRICAL EQUIPMENT . . . . .<br>(SEE FIGURE 7-12 FOR BKDN)                 |   |   |   |   |   |   | 1                    |                      | PAFDD       |

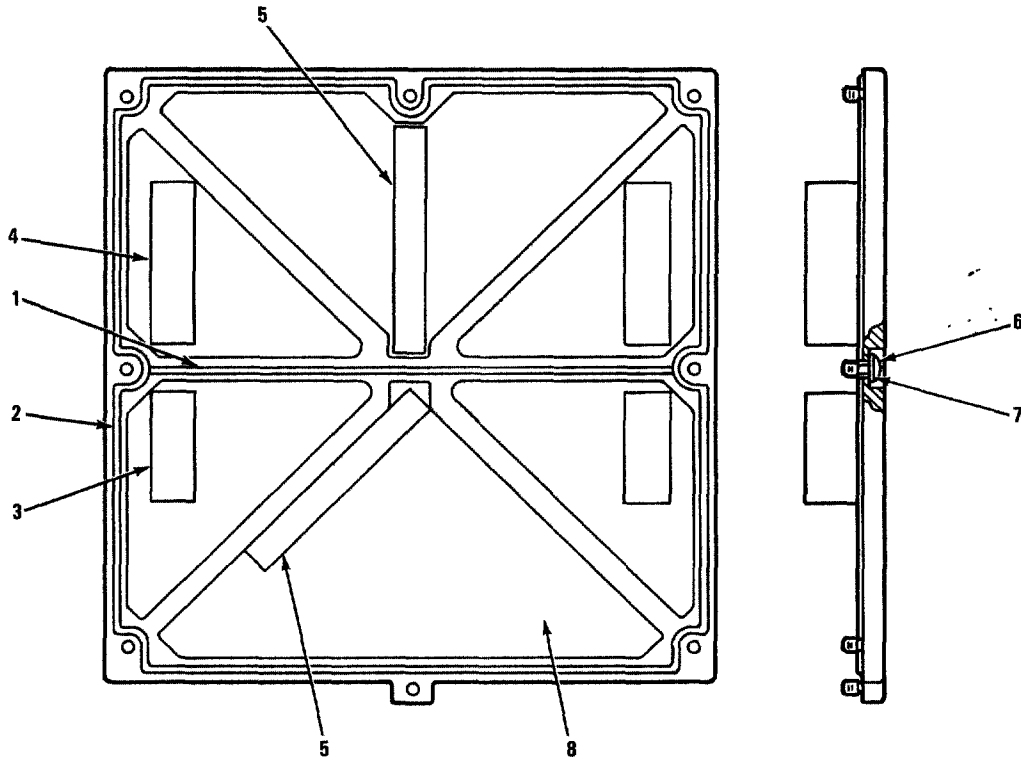

MX-61-119-IPB-3  
REF MAG DWG 660152 REV L  
PL 660152 REV J

FIGURE 7-3. DISTRIBUTION UNIT COVER



| FIG. &<br>INDEX<br>NO. | PART NUMBER | FSCM 1234567 | DESCRIPTION  | UNITS<br>PER<br>ASSY. | USABLE<br>ON<br>CODE | SMR<br>CODE |
|------------------------|-------------|--------------|--|-----------------------|----------------------|-------------|
| 7-3-                   | 660152-801  | 37695        | COVER, DISTRIBUTION UNIT. . . . .<br>(SEE FIGURE 7-2 FOR NHA)  | REF                   | A                    | XB          |
|                        | 660152-803  | 37695        | COVER, DISTRIBUTION UNIT. . . . .<br>(SEE FIGURE 7-2 FOR NHA)  | REF                   | B                    | XB          |
|                        | 660152-802  | 37695        | COVER, DISTRIBUTION UNIT. . . . .<br>(SEE FIGURE 7-13 FOR NHA) | REF                   |                      | XB          |
| -1                     | 348294-4    | 37695        | GASKET, RUBBER . . . . .                                       | 1                     | A                    | PAFZZ       |
| -2                     | 348294-1    | 37695        | GASKET, RUBBER . . . . .                                       | 1                     |                      | PAFZZ       |
| -3                     | 348297-15   | 37695        | PAD, RUBBER. . . . .   | 2                     | A                    | XB          |
| -4                     | 348297-14   | 37695        | PAD, RUBBER. . . . .   | 2                     | A                    | XB          |
| -5                     | 348297-3    | 37695        | PAD, RUBBER. . . . .   | 2                     | B                    | XB          |
| -6                     | 136555-1    | 37695        | SCREW, MODIFIED. . . . .                                       | 8                     |                      | PAFZZ       |
| -7                     | NAS620C6    | 80205        | WASHER. . . . .  | 8                     |                      | PAFZZ       |
| -8                     | 660152-1    | 37695        | COVER, DISTRIBUTION UNIT . . . . .                             | 1                     |                      | XA          |

A-USED ON 660152-801 ONLY  
 B-USED ON 660152-803 ONLY

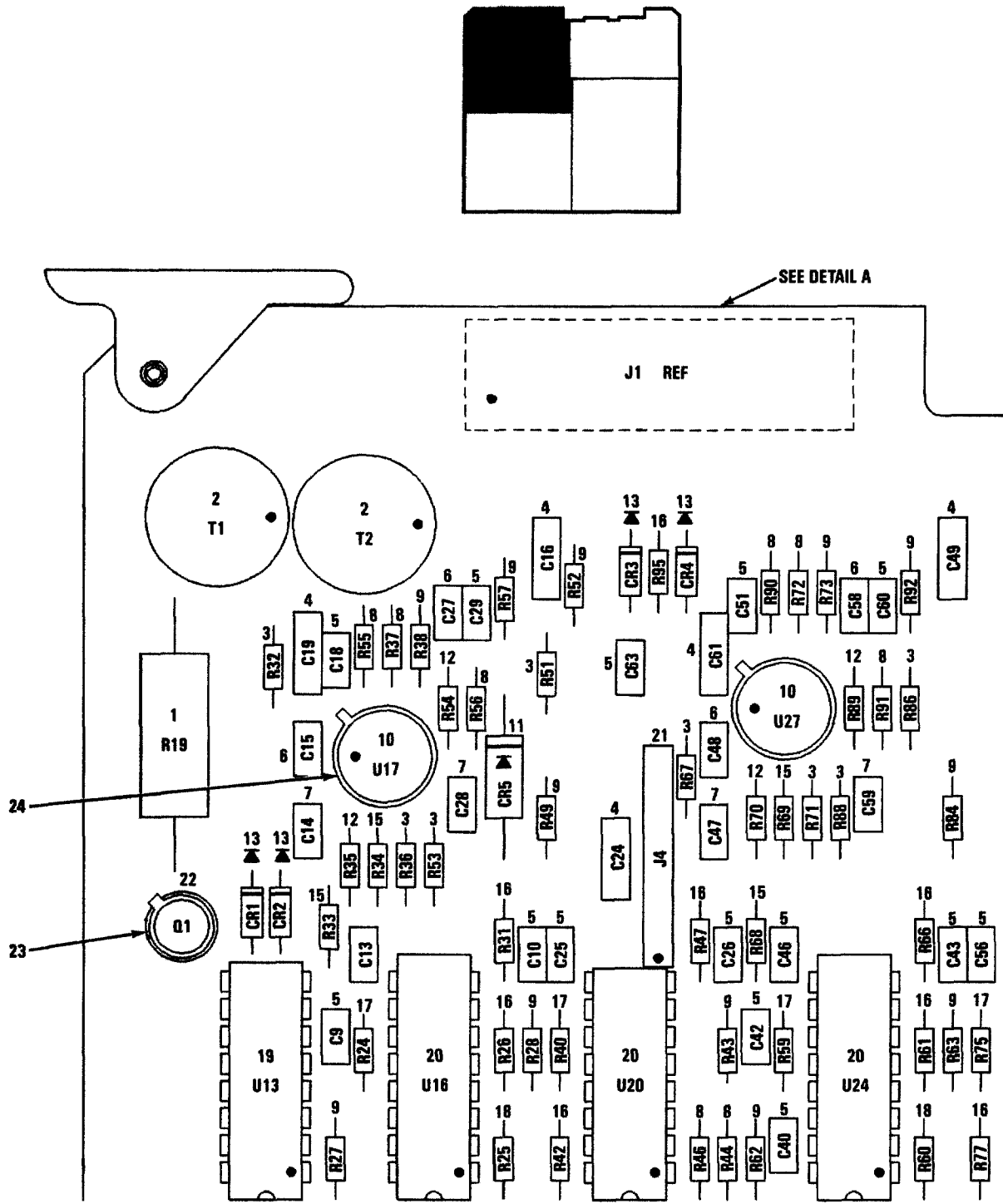

NOTE: REFERENCE DESIGNATIONS ARE ABBREVIATED.  
PREFIX WITH 1A1.

MX-61-119-IPB-4-1  
REF MAG DWG 812094 REV L  
PL 812094 REV AF

FIGURE 7-4. AUDIO INTERFACE CIRCUIT CARD ASSEMBLY (1) (SHEET 1 OF 4)

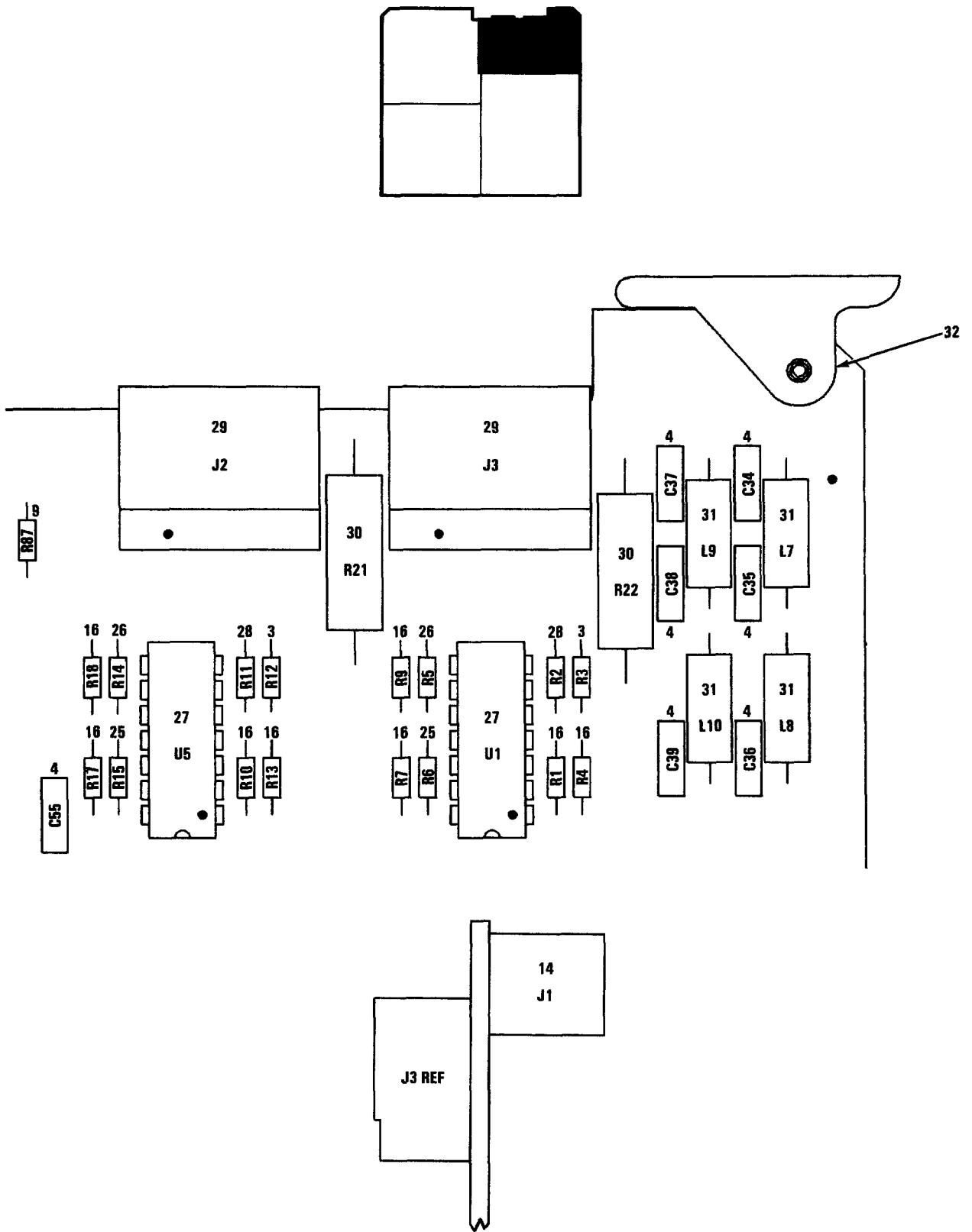

DETAIL A

NOTE: REFERENCE DESIGNATIONS ARE ABBREVIATED.  
PREFIX WITH 1A1.

MX-61-119-IPB-4.2

FIGURE 7-4. AUDIO INTERFACE CIRCUIT CARD ASSEMBLY (1) (SHEET 2 OF 4)

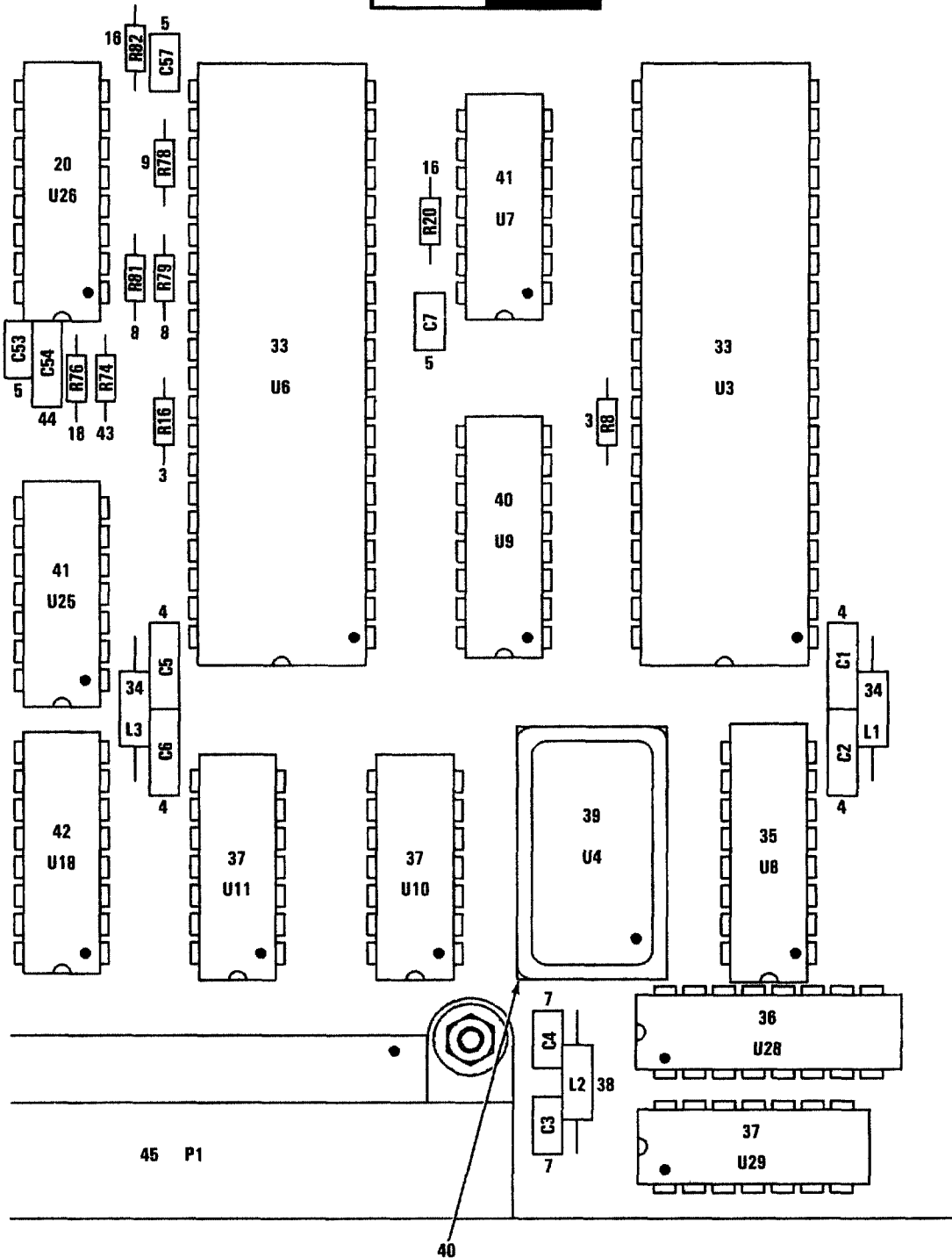
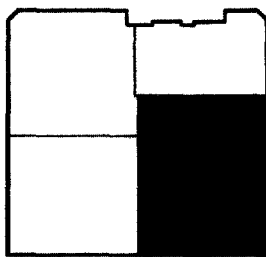

NOTE: REFERENCE DESIGNATIONS ARE ABBREVIATED.  
PREFIX WITH 1A1.

MX-61-119-IPB-4-3

FIGURE 7-4. AUDIO INTERFACE CIRCUIT CARD ASSEMBLY (1) (SHEET 3 OF 4)

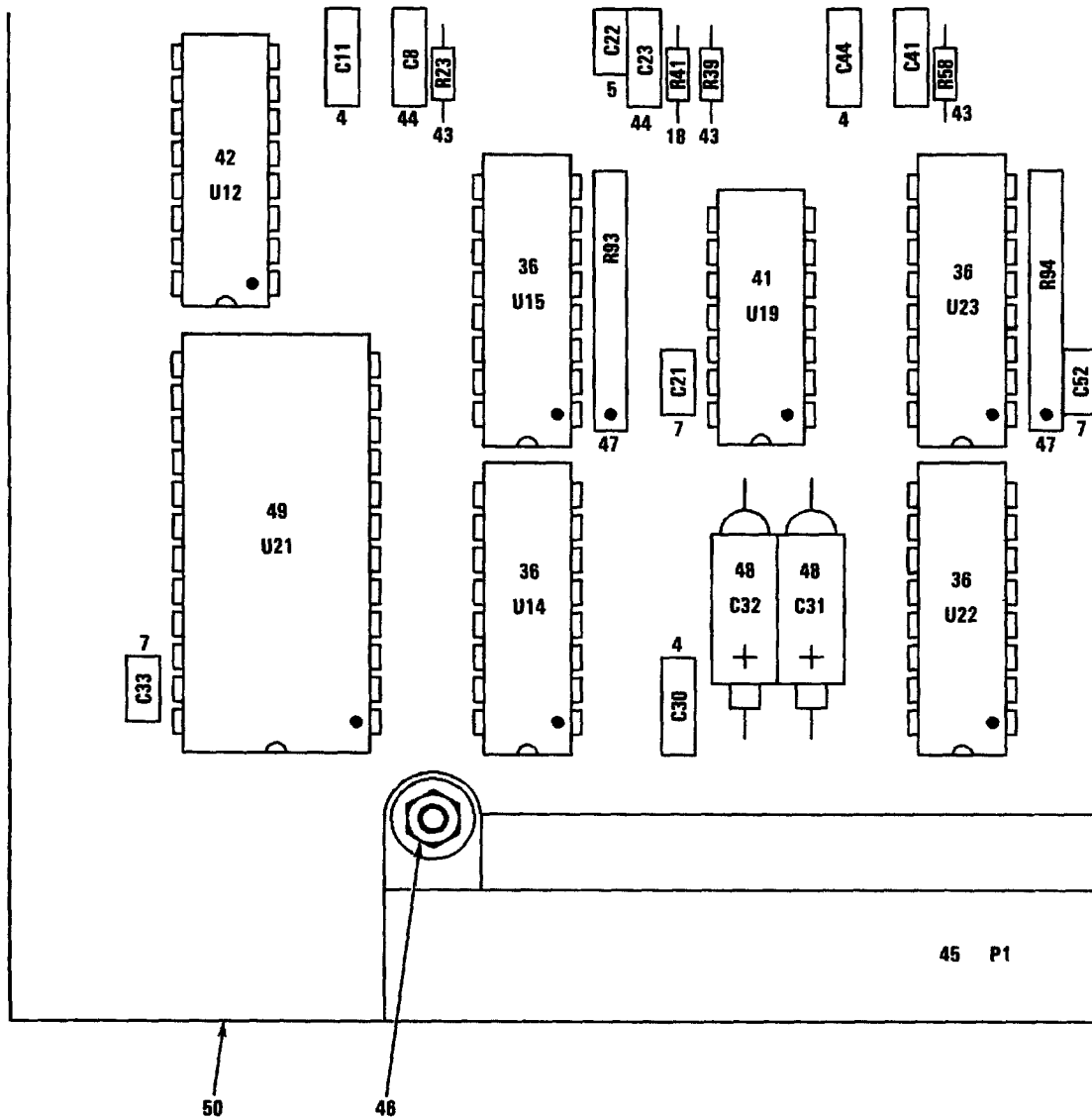
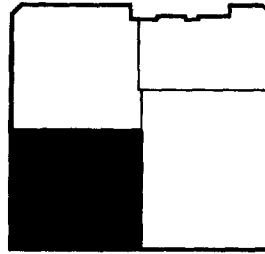

NOTE: REFERENCE DESIGNATIONS ARE ABBREVIATED.  
 PREFIX WITH 1A1.

MX-81-119-IPB-4-4

FIGURE 7-4. AUDIO INTERFACE CIRCUIT CARD ASSEMBLY (1) (SHEET 4 OF 4)

| FIG. & INDEX NO. | PART NUMBER       | FSCM 1234567 | DESCRIPTION  | UNITS PER ASBY. | USABLE ON CODE | SMR CODE |
|------------------|-------------------|--------------|--|-----------------|----------------|----------|
| 7-4-             | B12094-801        | 37695        | CIRCUIT CARD ASSEMBLY, AUDIO. . . . .<br>INTERFACE (1) (SEE FIGURE<br>7-2 FOR NHA) | REF             |                | PAFLD    |
| -1               | RCR320181JS       | 81349        | RESISTOR. . . . .  | 1               |                | PADZZ    |
| -2               | PICO-2996         | 31669        | TRANSFORMER, AUDIO FREQUENCY . . . . .<br>(MAGNAVOX SPEC CONT DWG<br>325291-1)     | 2               |                | PADZZ    |
| -3               | RCR050104JS       | 81349        | RESISTOR. . . . .  | 12              |                | PADZZ    |
| -4               | M39014/02-1419    | 81349        | CAPACITOR . . . . .  | 19              |                | PADZZ    |
|                  | *M39014/02-1407   | 81349        | CAPACITOR . . . . .  | 19              |                | PADZZ    |
| -5               | M39014/01-1593    | 81349        | CAPACITOR . . . . .  | 19              |                | PADZZ    |
|                  | *M39014/01-1473   | 81349        | CAPACITOR . . . . .  | 19              |                | PADZZ    |
| -6               | M39014/01-1357    | 81349        | CAPACITOR . . . . .  | 4               |                | PADZZ    |
|                  | *M39014/01-1237   | 81349        | CAPACITOR . . . . .  | 4               |                | PADZZ    |
| -7               | M39014/01-1575    | 81349        | CAPACITOR . . . . .  | 9               |                | PADZZ    |
|                  | *M39014/01-1455   | 81349        | CAPACITOR . . . . .  | 9               |                | PADZZ    |
| -8               | RCR050513JS       | 81349        | RESISTOR. . . . .  | 10              |                | PADZZ    |
| -9               | RCR050102JS       | 81349        | RESISTOR. . . . .  | 14              |                | PADZZ    |
| -10              | 616139-901        | 37695        | MICROCIRCUIT, LINEAR . . . . .   | 2               |                | PADZZ    |
| -11              | JANTXIN973B1      | 81349        | SEMICONDUCTOR DEVICE. . . . .  | 1               |                | PADZZ    |
| -12              | RCR050332JS       | 81349        | RESISTOR. . . . .  | 4               |                | PADZZ    |
| -13              | JANTX1N4454-1     | 81349        | SEMICONDUCTOR DEVICE. . . . .  | 4               |                | PADZZ    |
| -14              | 518B-157-11       | 00779        | CONNECTOR, RECEPTACLE. . . . .<br>(MAGNAVOX SPEC CONT<br>DWG 185972-9)             | 1               |                | PADZZ    |
| -15              | RCR050333JS       | 81349        | RESISTOR. . . . .  | 4               |                | PADZZ    |
| -16              | RCR050103JS       | 81349        | RESISTOR. . . . .  | 18              |                | PADZZ    |
| -17              | RCR050682JS       | 81349        | RESISTOR. . . . .  | 4               |                | PADZZ    |
| -18              | RCR050393JS       | 81349        | RESISTOR. . . . .  | 4               |                | PADZZ    |
| -19              | 616529-904        | 37695        | MICROCIRCUIT, LINEAR . . . . .   | 1               |                | PADZZ    |
| -20              | 617788-901        | 37695        | MICROCIRCUIT, LINEAR . . . . .   | 4               |                | PADZZ    |
| -21              | 186095-8          | 37695        | CONNECTOR, STRIP, MODIFIED. . . . .  | 1               |                | XB       |
| -22              | JANTX2N2907A      | 81349        | SEMICONDUCTOR DEVICE. . . . .  | 1               |                | PADZZ    |
| -23              | M38527/3-01N      | 81349        | MOUNTING PAD. . . . .  | 1               |                | PADZZ    |
| -24              | M38527/5-02D      | 81349        | MOUNTING PAD. . . . .  | 2               |                | XB       |
| -25              | RCR050202JS       | 81349        | RESISTOR. . . . .  | 2               |                | PADZZ    |
| -26              | RCR050562JS       | 81349        | RESISTOR. . . . .  | 2               |                | PADZZ    |
| -27              | 615506-901        | 37695        | MICROCIRCUIT, LINEAR . . . . .   | 2               |                | PADZZ    |
|                  | *M38510/11201BCB  | 81349        | MICROCIRCUIT. . . . .  | 2               |                | PADZZ    |
|                  | *JM38510/11201BCX | 81349        | MICROCIRCUIT. . . . .  | 2               |                | PADZZ    |
| -28              | RCR050242JS       | 81349        | RESISTOR. . . . .  | 2               |                | PADZZ    |
| -29              | 518B-101-18       | 00779        | CONNECTOR, RECEPTACLE (MAGNAVOX.<br>SPEC CONT DWG 186373-1)                        | 2               |                | PADZZ    |
| -30              | RWR89542R2FR      | 81349        | RESISTOR. . . . .  | 2               |                | PADZZ    |
| -31              | M39010/3A150KP    | 81349        | COIL. . . . .  | 4               |                | PADZZ    |
|                  | *M875085-1        | 96906        | COIL (ESDS) . . . . .  | 4               |                | PADZZ    |
| -32              | 8-203             | 18677        | EJECTOR, CIRCUIT CARD (MAGNAVOX.<br>SPEC CONT DWG 112781-3)                        | 2               |                | XB       |
| -33              | 79017010X         | 14933        | MICROCIRCUIT, DIGITAL (ESDS) . . . . .<br>(MAGNAVOX SPEC CONT DWG<br>645515-901)   | 2               |                | PADZZ    |
| -34              | M875085-19        | 96906        | COIL. . . . .  | 2               |                | PADZZ    |
| -35              | 7705801EX         | 14933        | MICROCIRCUIT, DIGITAL (ESDS) . . . . .<br>(MAGNAVOX SPEC CONT DWG<br>615745-901)   | 1               |                | PADZZ    |
| -36              | 615677-901        | 37695        | MICROCIRCUIT, DIGITAL (ESDS) . . . . .   | 5               |                | PADZZ    |
| -37              | 616501-901        | 37695        | MICROCIRCUIT, DIGITAL (ESDS) . . . . .   | 3               |                | PADZZ    |
|                  | *JM38510/05151BCX | 81349        | MICROCIRCUIT (ESDS) . . . . .  | 3               |                | PADZZ    |
| -38              | M875085-7         | 37695        | COIL. . . . .  | 1               |                | PADZZ    |
| -39              | T213-3.2 MHZ      | 57051        | OSCILLATOR, CRYSTAL (MAGNAVOX.<br>SPEC CONT DWG 626734-1)                          | 1               |                | PADZZ    |
| -40              | 616521-902        | 37695        | MICROCIRCUIT, DIGITAL (ESDS) . . . . .   | 1               |                | PADZZ    |
|                  | *JM38510/05753BEX | 81349        | MICROCIRCUIT (ESDS) . . . . .  | 1               |                | PADZZ    |
| -41              | 616492-901        | 37695        | MICROCIRCUIT, DIGITAL (ESDS) . . . . .   | 3               |                | PADZZ    |
|                  | *JM38510/05051BCX | 81349        | MICROCIRCUIT (ESDS) . . . . .  | 3               |                | PADZZ    |
| -42              | 616506-901        | 37695        | MICROCIRCUIT, DIGITAL (ESDS) . . . . .   | 2               |                | PADZZ    |
|                  | *JM38510/05553BEX | 81349        | MICROCIRCUIT (ESDS) . . . . .  | 2               |                | PADZZ    |
| -43              | RCR050155JS       | 81349        | RESISTOR. . . . .  | 4               |                | PADZZ    |
| -44              | M39014/02-1354    | 81349        | CAPACITOR . . . . .  | 4               |                | PADZZ    |

| FIG. &<br>INDEX<br>NO. | PART NUMBER       | FSCM  | 1234567 | DESCRIPTION                             | UNITS USABLE |            | SMR<br>CODE |
|------------------------|-------------------|-------|---------|---|--------------|------------|-------------|
|                        |                   |       |         |   | PER<br>ASSY. | ON<br>CODE |             |
| 7-4-                   | *M39014/02-1234   | 81349 |         | .CAPACITOR . . . . .                    | 4            |            | PADZZ       |
| -45                    | M55302/110-13     | 81349 |         | .CONNECTOR . . . . .                    | 1            |            | PADZZ       |
| -46                    | M851957-4         | 96906 |         | .SCREW (AP) . . . . .                   | 2            |            | PAFZZ       |
|                        | M815795-802       | 96906 |         | .WASHER (AP) . . . . .                  | 2            |            | PAFZZ       |
|                        | M83533B-134       | 96906 |         | .WASHER (AP) . . . . .                  | 2            |            | PAFZZ       |
|                        | NAS671C2          | 80205 |         | .NUT (AP) . . . . .                     | 2            |            | PAFZZ       |
| -47                    | M8340105K10030C   | 81349 |         | .RESISTOR . . . . .                     | 2            |            | PADZZ       |
| -48                    | M39003/01-3006    | 81349 |         | .CAPACITOR . . . . .                    | 2            |            | PADZZ       |
|                        | *M39003/01-2286   | 81349 |         | .CAPACITOR . . . . .                    | 2            |            | PADZZ       |
| -49                    | 61999B-2          | 37695 |         | .MICROCIRCUIT, DIGITAL (ESDS) . . . . . | 1            |            | PADZZ       |
|                        | =CD4508BD/3       | 02735 |         | .MICROCIRCUIT, DIGITAL (ESDS) . . . . . | 1            |            | PADZZ       |
|                        | *JM38510/17602BJX | 81349 |         | .MICROCIRCUIT (ESDS) . . . . .          | 1            |            | PADZZ       |
| -50                    | 412039-1          | 37695 |         | .PRINTED WIRING BOARD . . . . .         | 1            |            | XB          |

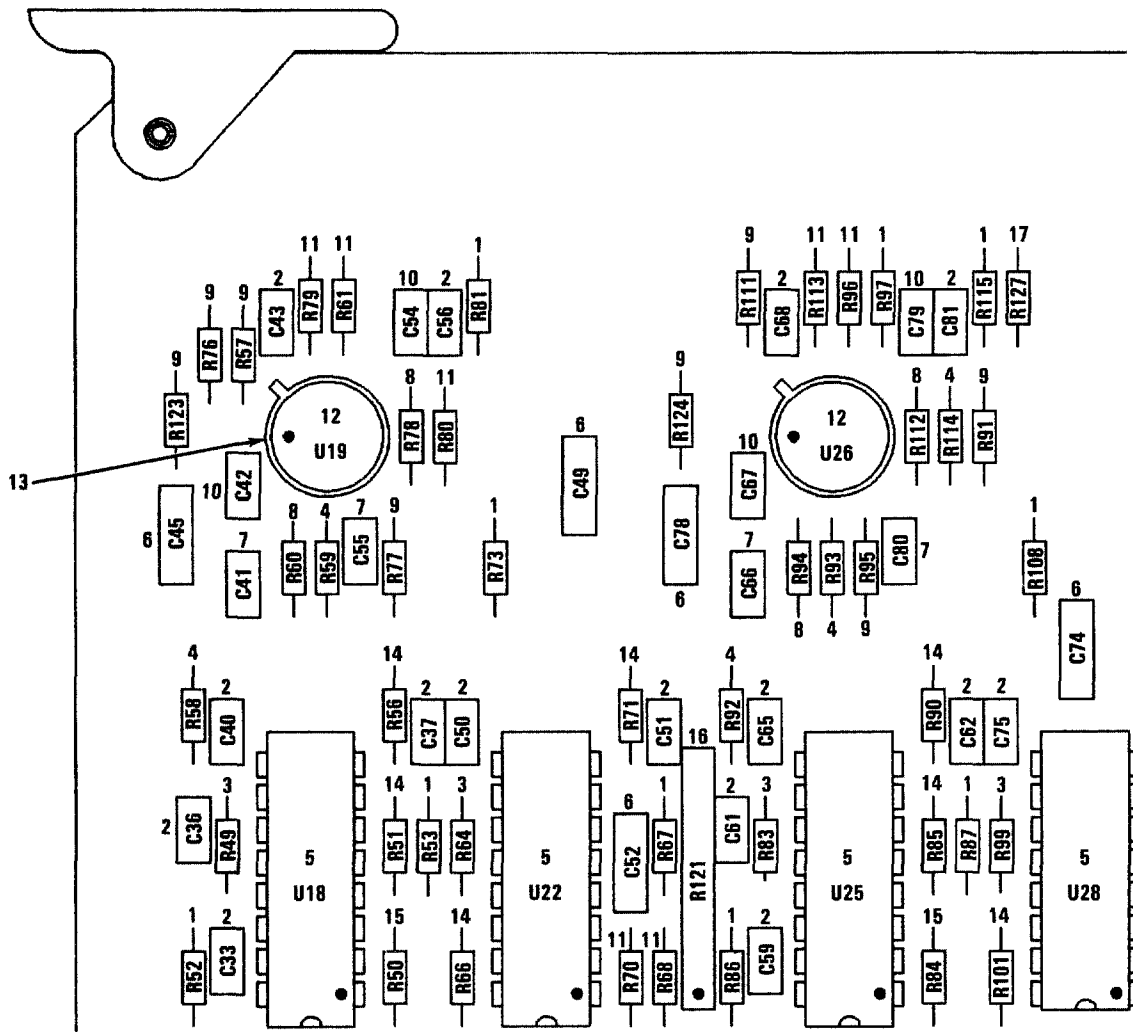
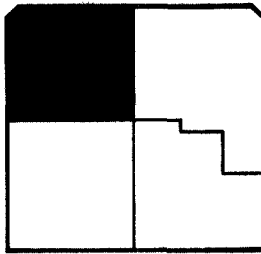

NOTE: REFERENCE DESIGNATIONS ARE ABBREVIATED.  
 PREFIX WITH 1A2.

MX-61-119-IPB-5-1  
 REF MAG DWG 812095 REV J  
 PL 812095 REV AB

FIGURE 7-5. AUDIO INTERFACE CIRCUIT CARD ASSEMBLY (2) (SHEET 1 OF 4)



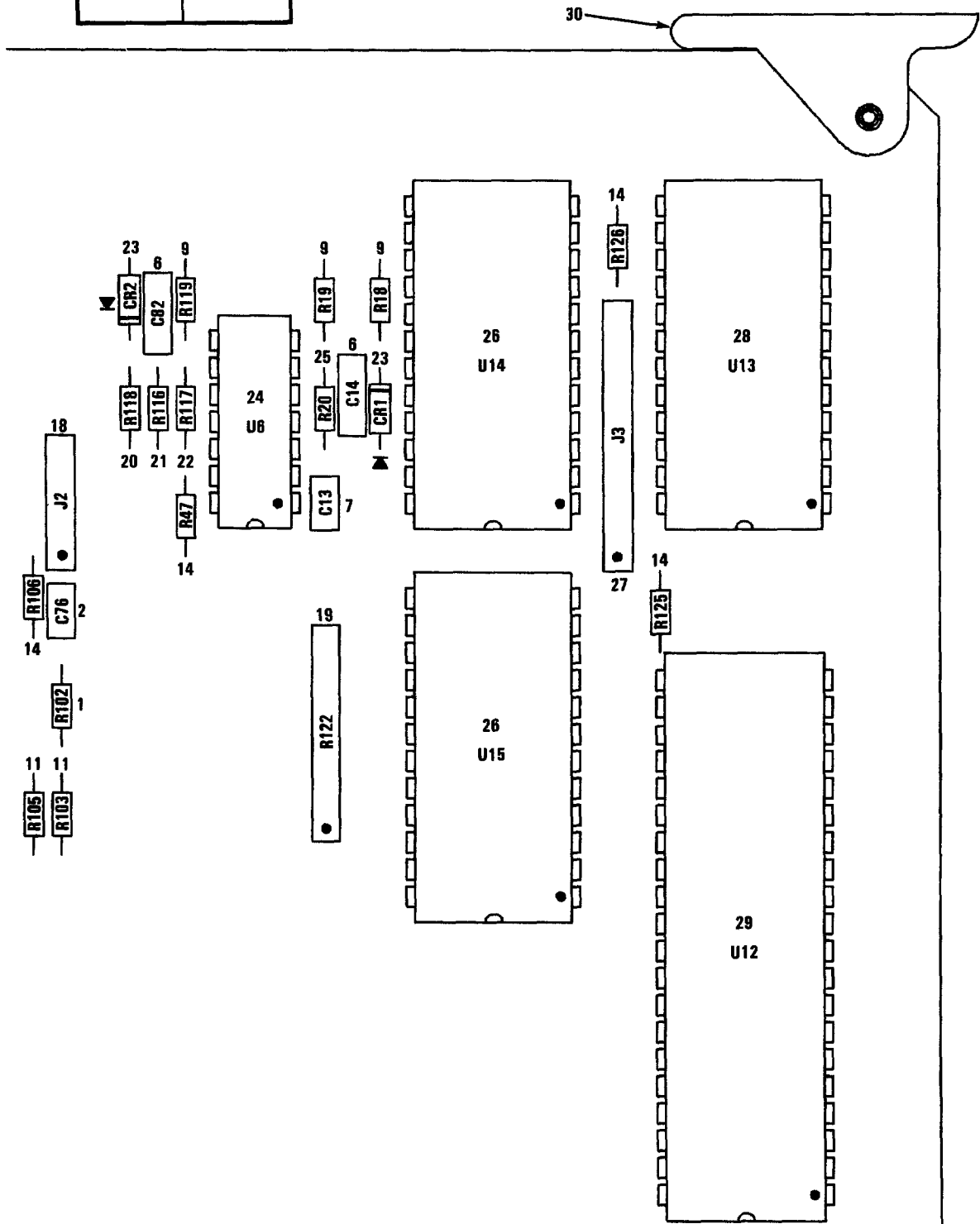
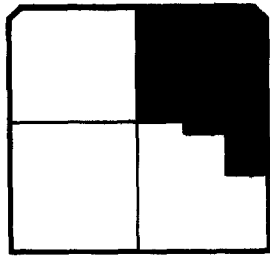

NOTE: REFERENCE DESIGNATIONS ARE ABBREVIATED.  
 PREFIX WITH 1A2.

MX-61-119-IPB-5-2

FIGURE 7-5. AUDIO INTERFACE CIRCUIT CARD ASSEMBLY (2) (SHEET 2 OF 4)

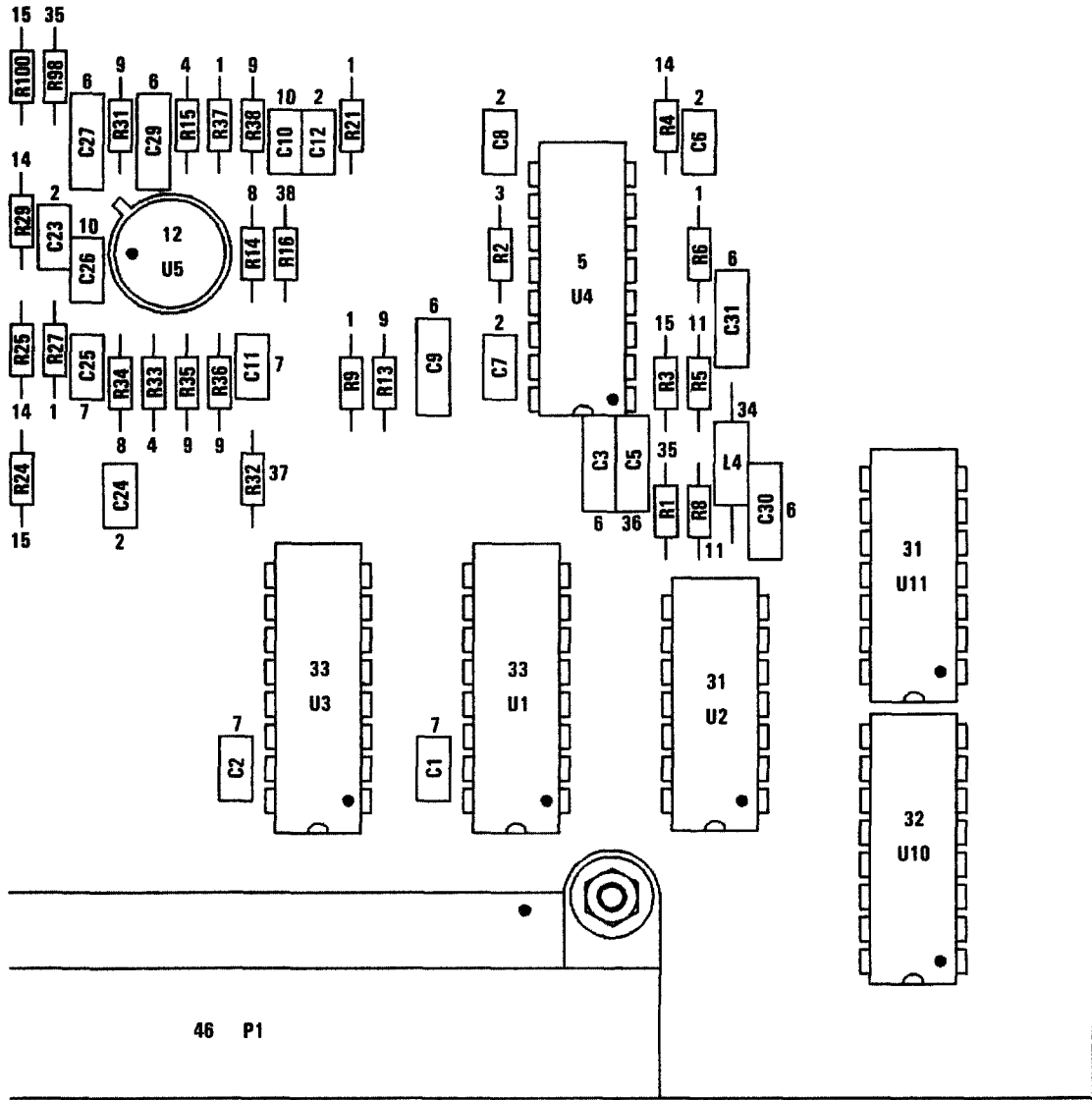
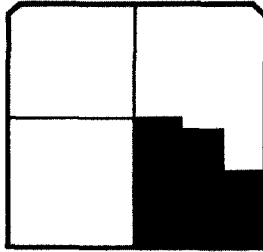

NOTE: REFERENCE DESIGNATIONS ARE ABBREVIATED.  
 PREFIX WITH 1A2.

MX-61-119-IPB-5-3

FIGURE 7-5. AUDIO INTERFACE CIRCUIT CARD ASSEMBLY (2) (SHEET 3 OF 4)

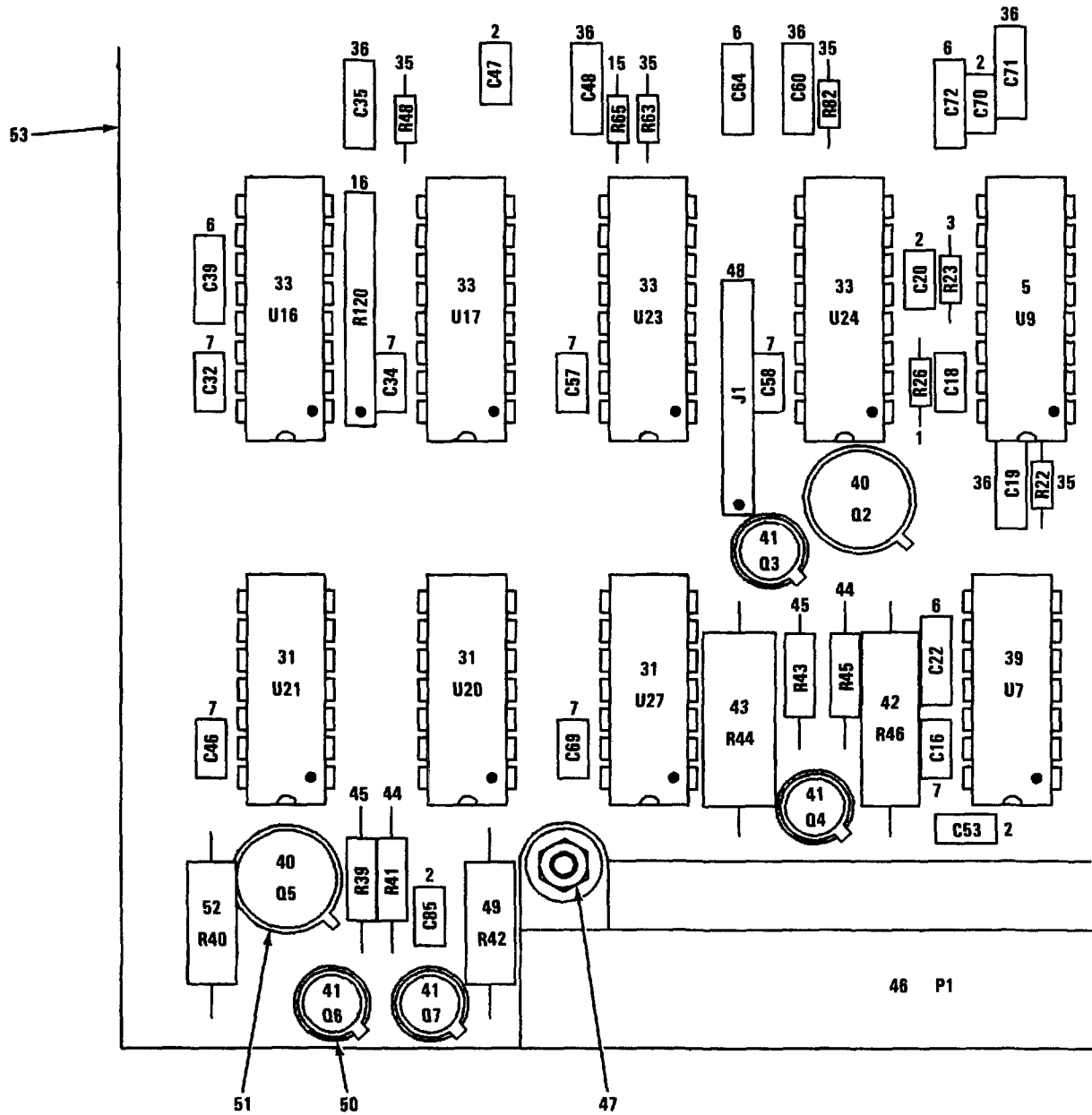
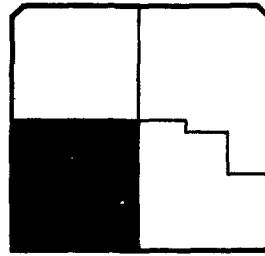

NOTE: REFERENCE DESIGNATIONS ARE ABBREVIATED.  
 PREFIX WITH 1A2.

MX-61-119-IPB-5-4

FIGURE 7-5. AUDIO INTERFACE CIRCUIT CARD ASSEMBLY (2) (SHEET 4 OF 4)

| FIG. &<br>INDEX<br>NO. | PART NUMBER       | FSCM  | 1234567 | DESCRIPTION  | UNITS<br>PER<br>ASSY. | USABLE<br>ON<br>CODE | SMR<br>CODE |
|------------------------|-------------------|-------|---------|--|-----------------------|----------------------|-------------|
| 7-5-                   | B12095-801        | 37695 |         | CIRCUIT CARD ASSEMBLY, AUDIO.<br>INTERFACE (2) (SEE FIGURE<br>7-2 FOR NHA) | REF                   |                      | PAFLD       |
| -1                     | RCR050102JS       | 81349 |         | RESISTOR.  | 17                    |                      | PADZZ       |
| -2                     | M39014/01-1593    | 81349 |         | CAPACITOR  | 28                    |                      | PADZZ       |
|                        | *M39014/01-1473   | 81349 |         | CAPACITOR  | 28                    |                      | PADZZ       |
| -3                     | RCR050682JS       | 81349 |         | RESISTOR.  | 6                     |                      | PADZZ       |
| -4                     | RCR050333JS       | 81349 |         | RESISTOR.  | 7                     |                      | PADZZ       |
| -5                     | 617788-901        | 37695 |         | MICROCIRCUIT, LINEAR   | 6                     |                      | PADZZ       |
| -6                     | M39014/02-1419    | 81349 |         | CAPACITOR  | 17                    |                      | PADZZ       |
|                        | *M39014/02-1407   | 81349 |         | CAPACITOR  | 17                    |                      | PADZZ       |
| -7                     | M39014/01-1575    | 81349 |         | CAPACITOR  | 16                    |                      | PADZZ       |
|                        | *M39014/01-1455   | 81349 |         | CAPACITOR  | 16                    |                      | PADZZ       |
| -8                     | RCR050332JS       | 81349 |         | RESISTOR.  | 6                     |                      | PADZZ       |
| -9                     | RCR050104JS       | 81349 |         | RESISTOR.  | 16                    |                      | PADZZ       |
| -10                    | M39014/01-1357    | 81349 |         | CAPACITOR  | 6                     |                      | PADZZ       |
|                        | *M39014/01-1237   | 81349 |         | CAPACITOR  | 6                     |                      | PADZZ       |
| -11                    | RCR050513JS       | 81349 |         | RESISTOR.  | 11                    |                      | PADZZ       |
| -12                    | 616139-901        | 37695 |         | MICROCIRCUIT, LINEAR   | 3                     |                      | PADZZ       |
| -13                    | M38527/5-02D      | 81349 |         | MOUNTING PADS, INSULATOR DISK.   | 3                     |                      | XB          |
| -14                    | RCR050103JS       | 81349 |         | RESISTOR.  | 14                    |                      | PADZZ       |
| -15                    | RCR050393JS       | 81349 |         | RESISTOR.  | 6                     |                      | PADZZ       |
| -16                    | M8340105K10030C   | 81349 |         | RESISTOR.  | 2                     |                      | PADZZ       |
| -17                    | RCR050822JS       | 81349 |         | RESISTOR.  | 1                     |                      | PADZZ       |
| -18                    | 186095-5          | 37695 |         | CONNECTOR, STRIP, MODIFIED.  | 1                     |                      | XB          |
| -19                    | M8340105K10020C   | 81349 |         | RESISTOR.  | 1                     |                      | PADZZ       |
| -20                    | RCR050273JS       | 81349 |         | RESISTOR.  | 1                     |                      | PADZZ       |
| -21                    | RCR050514JS       | 81349 |         | RESISTOR.  | 1                     |                      | PADZZ       |
| -22                    | RCR050272JS       | 81349 |         | RESISTOR.  | 1                     |                      | PADZZ       |
| -23                    | JANTX1N4454-1     | 81349 |         | SEMICONDUCTOR DEVICE.  | 2                     |                      | PADZZ       |
| -24                    | 615506-901        | 37695 |         | MICROCIRCUIT, LINEAR   | 1                     |                      | PADZZ       |
|                        | =M38510/11201BCB  | 81349 |         | MICROCIRCUIT.  | 1                     |                      | PADZZ       |
|                        | *JM38510/11201BCX | 81349 |         | MICROCIRCUIT.  | 1                     |                      | PADZZ       |
| -25                    | RCR050105JS       | 81349 |         | RESISTOR.  | 1                     |                      | PADZZ       |
| -26                    | 619998-2          | 37695 |         | MICROCIRCUIT, DIGITAL (ESDS)   | 2                     |                      | PADZZ       |
|                        | =CD45088D/3       | 02735 |         | MICROCIRCUIT, DIGITAL (ESDS)   | 2                     |                      | PADZZ       |
|                        | *JM38510/17602BJX | 81349 |         | MICROCIRCUIT (ESDS)  | 2                     |                      | PADZZ       |
| -27                    | 186095-10         | 37695 |         | CONNECTOR, STRIP, MODIFIED.  | 1                     |                      | XB          |
| -28                    | 645503-901        | 37695 |         | MICROCIRCUIT, DIGITAL (ESDS)   | 1                     |                      | PADZZ       |
|                        | =M38510/17301BJB  | 81349 |         | MICROCIRCUIT (ESDS)  | 1                     |                      | PADZZ       |
|                        | *JM38510/17301BJX | 81349 |         | MICROCIRCUIT (ESDS)  | 1                     |                      | PADZZ       |
| -29                    | 79017010X         | 14933 |         | MICROCIRCUIT, DIGITAL (ESDS)<br>(MAGNAVOX SPEC CONT DWG<br>645515-901)     | 1                     |                      | PADZZ       |
| -30                    | B-203             | 18677 |         | EJECTOR, CIRCUIT CARD (MAGNAVOX.<br>SPEC CONT DWG 112781-3)                | 2                     |                      | XB          |
| -31                    | 616492-901        | 37695 |         | MICROCIRCUIT, DIGITAL (ESDS)   | 5                     |                      | PADZZ       |
|                        | =JM38510/05051BCX | 81349 |         | MICROCIRCUIT (ESDS)  | 5                     |                      | PADZZ       |
| -32                    | 616521-902        | 37695 |         | MICROCIRCUIT (ESDS)  | 1                     |                      | PADZZ       |
|                        | =JM38510/05753BEX | 81349 |         | MICROCIRCUIT (ESDS)  | 1                     |                      | PADZZ       |
| -33                    | 615677-901        | 37695 |         | MICROCIRCUIT (ESDS)  | 6                     |                      | PADZZ       |
| -34                    | MS75085-19        | 96906 |         | COIL.  | 1                     |                      | PADZZ       |
| -35                    | RCR050155JS       | 81349 |         | RESISTOR.  | 6                     |                      | PADZZ       |
| -36                    | M39014/02-1354    | 81349 |         | CAPACITOR  | 6                     |                      | PADZZ       |
|                        | *M39014/02-1234   | 81349 |         | CAPACITOR  | 6                     |                      | PADZZ       |
| -37                    | RCR050163JS       | 81349 |         | RESISTOR.  | 1                     |                      | PADZZ       |
| -38                    | RCR050473JS       | 81349 |         | RESISTOR.  | 1                     |                      | PADZZ       |
| -39                    | 616501-901        | 37695 |         | MICROCIRCUIT, DIGITAL (ESDS)   | 1                     |                      | PADZZ       |
|                        | =JM38510/05151BCX | 81349 |         | MICROCIRCUIT (ESDS)  | 1                     |                      | PADZZ       |
| -40                    | JANTX2N2905A      | 81349 |         | SEMICONDUCTOR DEVICE.  | 2                     |                      | PADZZ       |
| -41                    | JANTX2N2907A      | 81349 |         | SEMICONDUCTOR DEVICE.  | 4                     |                      | PADZZ       |
| -42                    | RCR3205R6JS       | 81349 |         | RESISTOR.  | 1                     |                      | PADZZ       |
| -43                    | RCR320390JS       | 81349 |         | RESISTOR.  | 1                     |                      | PADZZ       |
| -44                    | RCR070103JS       | 81349 |         | RESISTOR.  | 2                     |                      | PADZZ       |
| -45                    | RCR070102JS       | 81349 |         | RESISTOR.  | 2                     |                      | PADZZ       |
| -46                    | M55302/110-13     | 81349 |         | CONNECTOR  | 1                     |                      | PADZZ       |
| -47                    | MS51957-4         | 96906 |         | SCREW (AP).  | 2                     |                      | PADZZ       |
|                        | MS15795-802       | 96906 |         | WASHER (AP)  | 2                     |                      | PADZZ       |
|                        | M835338-134       | 96906 |         | WASHER (AP)  | 2                     |                      | PADZZ       |

| FIG. &<br>INDEX<br>NO. | PART NUMBER  | FSCM  | 1234567 | DESCRIPTION                   | UNITS USABLE |            |             |
|------------------------|--------------|-------|---------|-------------------------------|--------------|------------|-------------|
|                        |              |       |         |                               | PER<br>ASSY. | ON<br>CODE | SMR<br>CODE |
| 7-5-                   | NAB671C2     | 80205 |         | . NUT (AP).                   | 2            |            | PADZZ       |
| -48                    | 186095-8     | 37695 |         | . CONNECTOR, STRIP, MODIFIED. | 1            |            | XB          |
| -49                    | RCR200270JS  | 81349 |         | . RESISTOR.                   | 1            |            | PADZZ       |
| -50                    | M38527/3-01N | 81349 |         | . MOUNTING PAD.               | 4            |            | PADZZ       |
| -51                    | M38527/2-05  | 81349 |         | . MOUNTING PAD.               | 2            |            | XB          |
| -52                    | RCR200391JS  | 81349 |         | . RESISTOR.                   | 1            |            | PADZZ       |
| -53                    | 412040-1     | 37695 |         | . PRINTED WIRING BOARD.       | 1            |            | XB          |

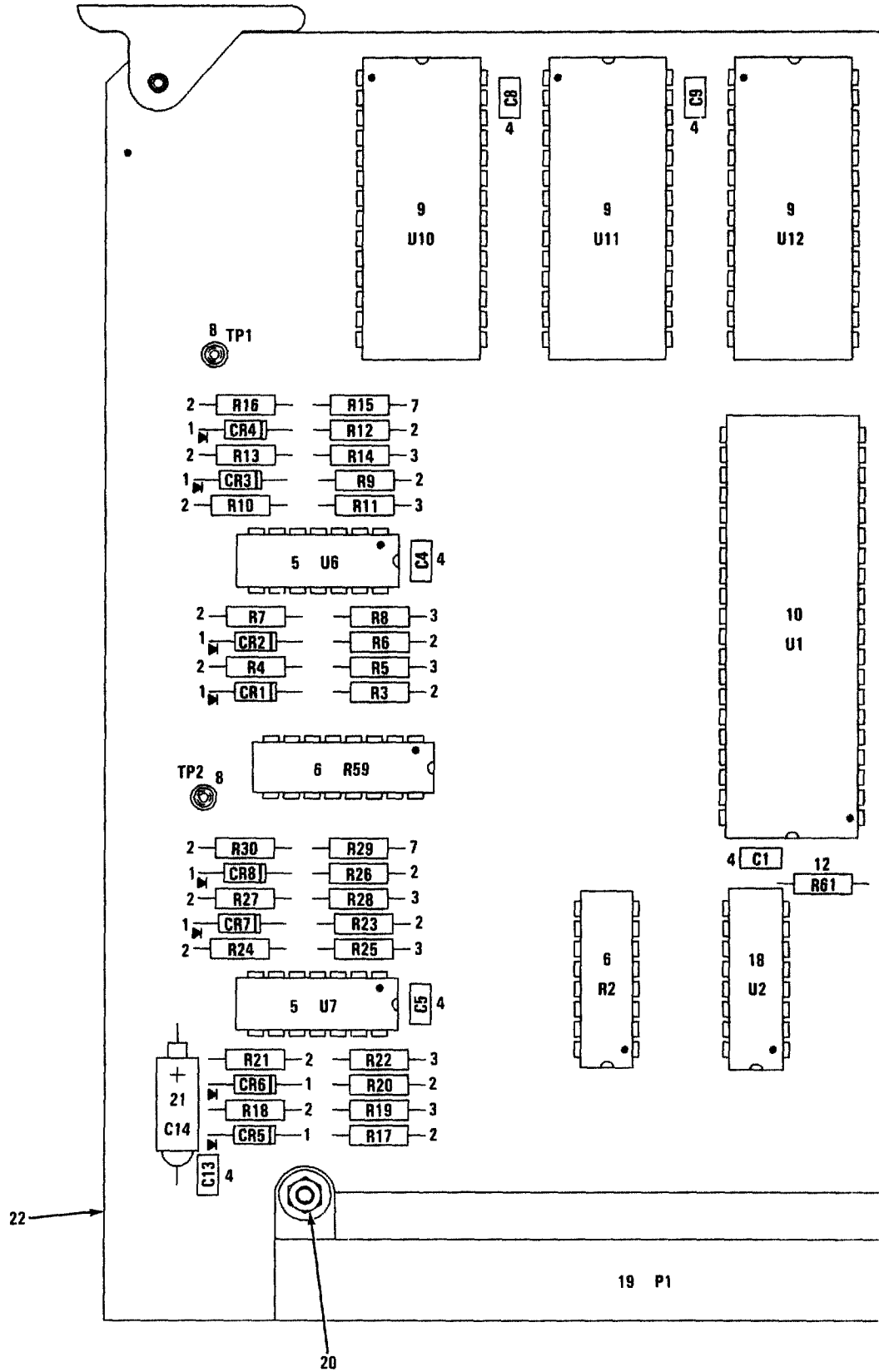
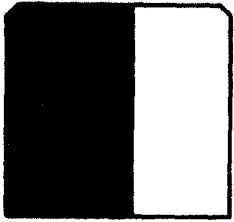

NOTE: REFERENCE DESIGNATIONS ARE ABBREVIATED.  
PREFIX WITH 1A3.

MX-61-119-IPB-6-1  
REF MAG DWG 812154 REV D  
PL 812154 REV T

FIGURE 7-6. RED INTERFACE CIRCUIT CARD ASSEMBLY (SHEET 1 OF 2)

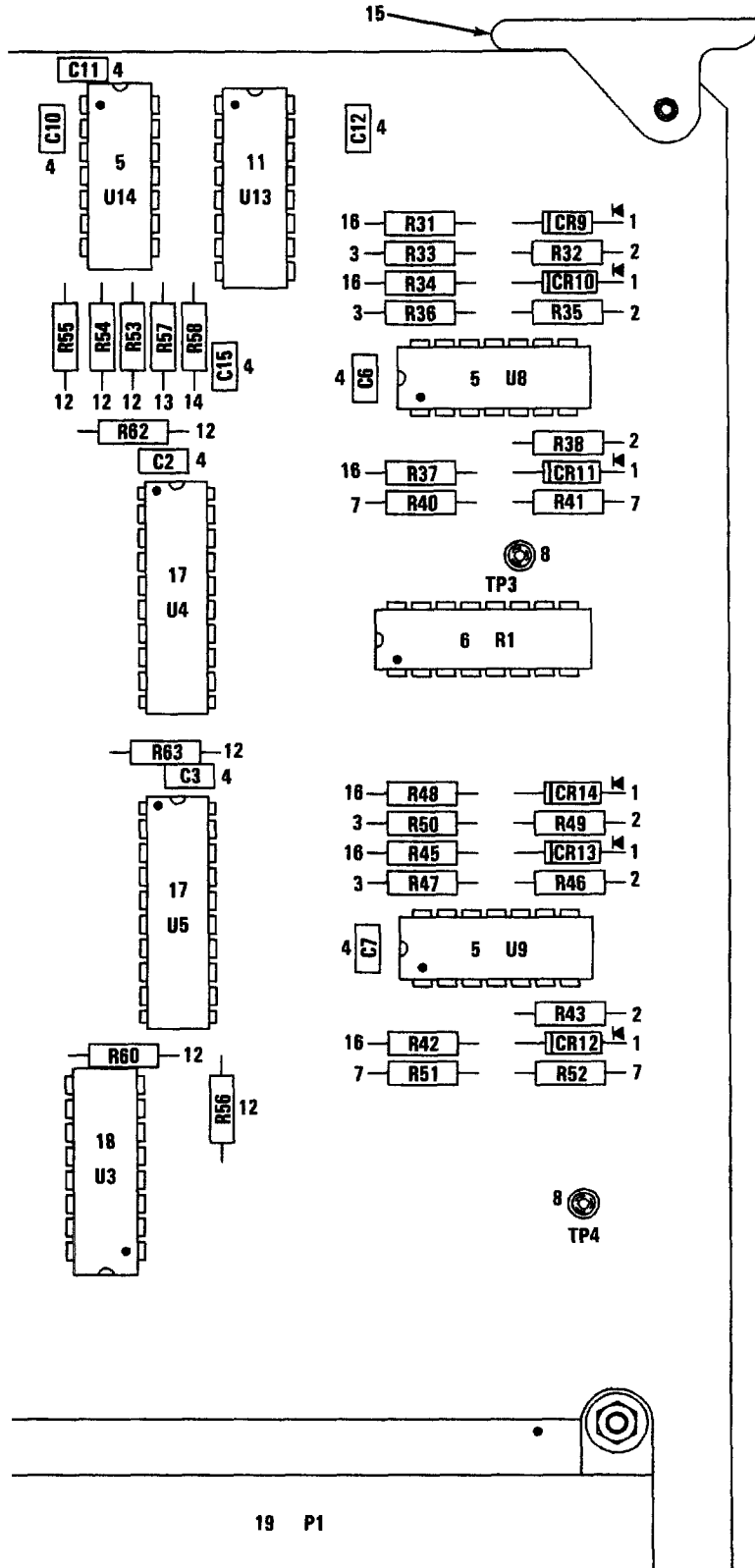
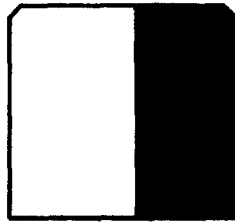

NOTE: REFERENCE DESIGNATIONS ARE ABBREVIATED.  
 PREFIX WITH 1A3.

MX-61-119-IPB-6-2

FIGURE 7-6. RED INTERFACE CIRCUIT CARD ASSEMBLY (SHEET 2 OF 2)

| FIG. &<br>INDEX<br>NO. | PART NUMBER       | FSCM 1234567 | DESCRIPTION  | UNITS<br>PER<br>ASSY. | USABLE<br>ON<br>CODE | SMR<br>CODE |
|------------------------|-------------------|--------------|--|-----------------------|----------------------|-------------|
| 7-6-                   | B12154-801        | 37695        | CIRCUIT CARD ASSEMBLY, RED.<br>INTERFACE (SEE FIGURE 7-2<br>FOR NHA) | REF                   |                      | PAPLD       |
| -1                     | JANTX1N752A1      | 81349        | SEMICONDUCTOR DEVICE.  | 14                    |                      | PADZZ       |
| -2                     | RCR070393JS       | 81349        | RESISTOR.  | 24                    |                      | PADZZ       |
| -3                     | RCR070105JS       | 81349        | RESISTOR.  | 12                    |                      | PADZZ       |
| -4                     | M39014/01-1593    | 81349        | CAPACITOR  | 14                    |                      | PADZZ       |
|                        | *M39014/01-1473   | 81349        | CAPACITOR  | 14                    |                      | PADZZ       |
| -5                     | 615506-901        | 37695        | MICROCIRCUIT, LINEAR   | 5                     |                      | PADZZ       |
|                        | *M38510/11201BCB  | 81349        | MICROCIRCUIT.  | 5                     |                      | PADZZ       |
|                        | *JM38510/11201BCX | 81349        | MICROCIRCUIT.  | 5                     |                      | PADZZ       |
| -6                     | MB340102M10020B   | 81349        | RESISTOR.  | 3                     |                      | PADZZ       |
| -7                     | RCR070623JS       | 81349        | RESISTOR.  | 6                     |                      | PADZZ       |
| -8                     | SE16XC018         | 81349        | TERMINAL.  | 4                     |                      | PADZZ       |
| -9                     | 646197-901        | 37695        | MICROCIRCUIT, DIGITAL (ESDS)   | 3                     |                      | PADZZ       |
| -10                    | 616489-902        | 37695        | MICROCIRCUIT, DIGITAL (ESDS)   | 1                     |                      | PADZZ       |
| -11                    | 615279-901        | 37695        | MICROCIRCUIT, DIGITAL.   | 1                     |                      | PADZZ       |
|                        | *M38510/30701BEB  | 81349        | MICROCIRCUIT.  | 1                     |                      | PADZZ       |
|                        | *JM38510/30701BEX | 81349        | MICROCIRCUIT.  | 1                     |                      | PADZZ       |
| -12                    | RCR070103JS       | 81349        | RESISTOR.  | 8                     |                      | PADZZ       |
| -13                    | RCR070302JS       | 81349        | RESISTOR.  | 1                     |                      | PADZZ       |
| -14                    | RCR070202JS       | 81349        | RESISTOR.  | 1                     |                      | PADZZ       |
| -15                    | S-203             | 18677        | EJECTOR, CIRCUIT CARD (MAGNAVOX.<br>SPEC CONT DWG 112781-3)          | 2                     |                      | XB          |
| -16                    | RCR070102JS       | 81349        | RESISTOR.  | 6                     |                      | PADZZ       |
| -17                    | AM25LS299DMG      | 34335        | MICROCIRCUIT, DIGITAL (MAGNAVOX.<br>SPEC CONT DWG 615886-901)        | 2                     |                      | PADZZ       |
| -18                    | 616529-904        | 37695        | MICROCIRCUIT, LINEAR   | 2                     |                      | PADZZ       |
| -19                    | M55302/110-16     | 81349        | CONNECTOR  | 1                     |                      | PADZZ       |
| -20                    | MS51957-4         | 96906        | SCREW (AP).  | 2                     |                      | PADZZ       |
|                        | MS15795-802       | 96906        | WASHER (AP)  | 2                     |                      | PADZZ       |
|                        | MS35338-134       | 96906        | WASHER (AP)  | 2                     |                      | PADZZ       |
|                        | NAS671C2          | 80205        | NUT (AP).  | 2                     |                      | PADZZ       |
| -21                    | M39003/01-3006    | 81349        | CAPACITOR  | 1                     |                      | PADZZ       |
|                        | *M39003/01-2286   | 81349        | CAPACITOR  | 1                     |                      | PADZZ       |
| -22                    | 412044-1          | 37695        | PRINTED WIRING BOARD.  | 1                     |                      | XB          |



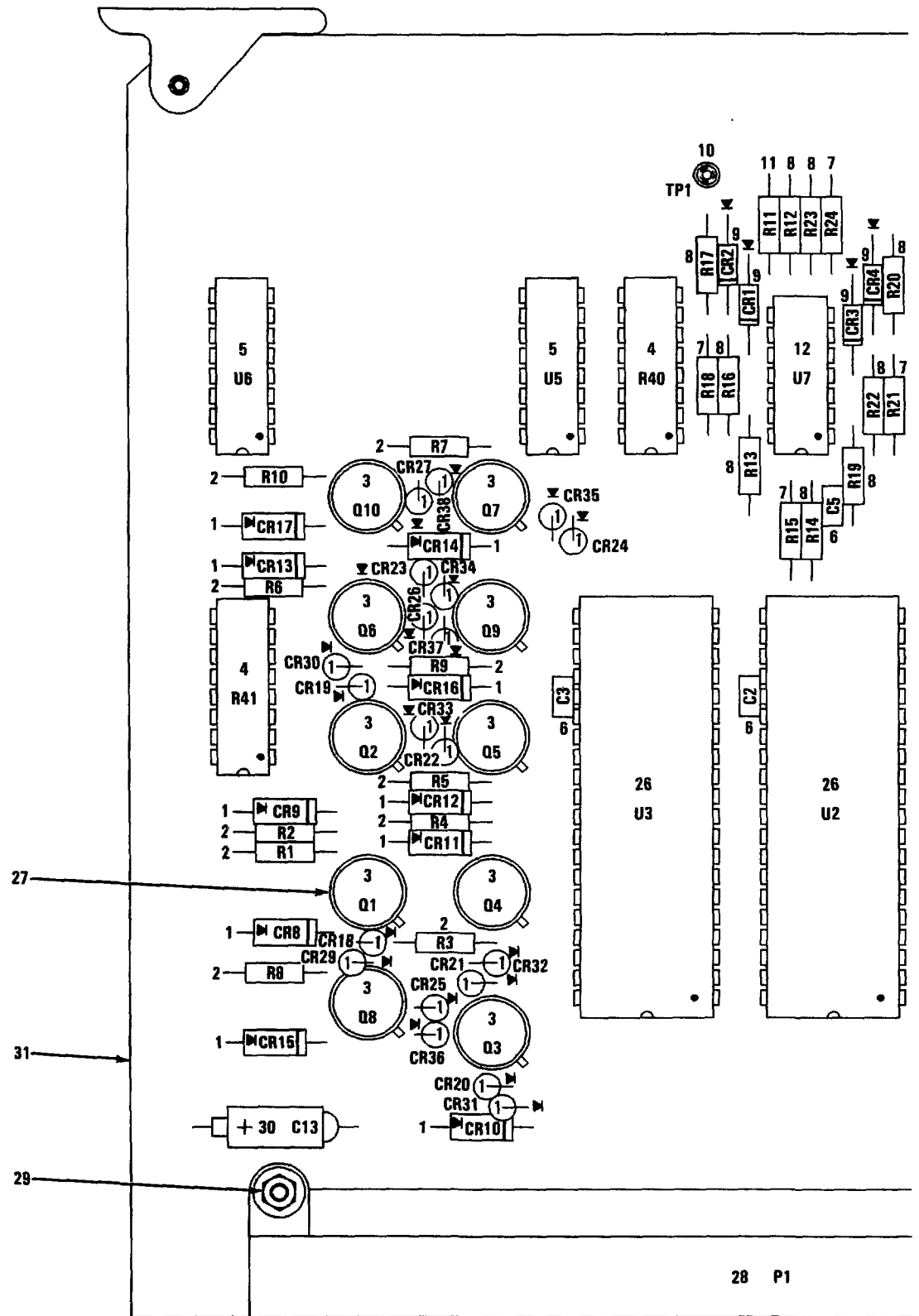
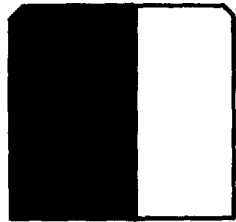

NOTE: REFERENCE DESIGNATIONS ARE ABBREVIATED.  
PREFIX WITH 1A4.

MX-81-119-IPB-7-1  
REF MAG DWG 812117 REV G  
PL 812117 REV Y

FIGURE 7-7. BLACK INTERFACE CIRCUIT CARD ASSEMBLY (SHEET 1 OF 2)

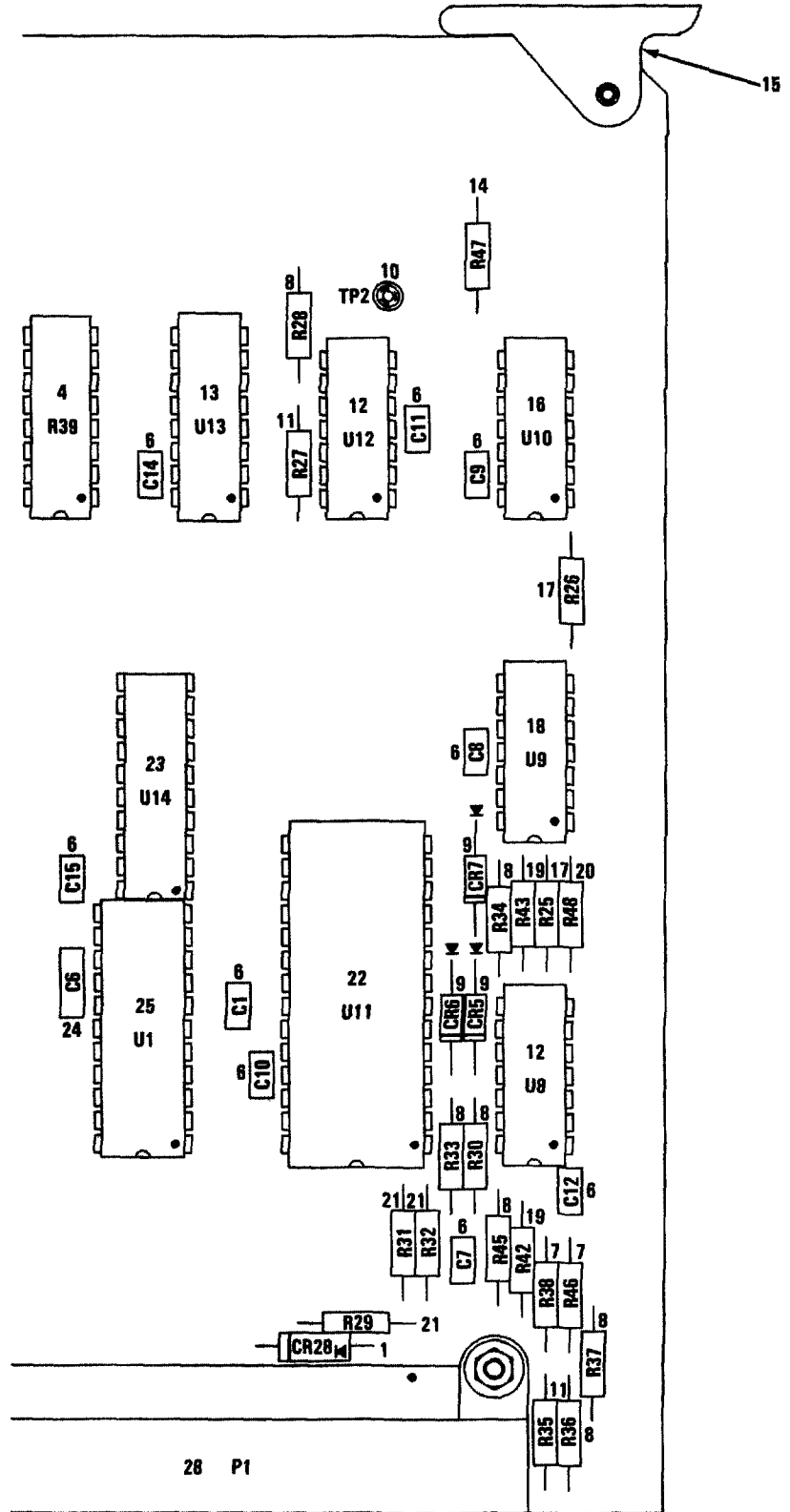
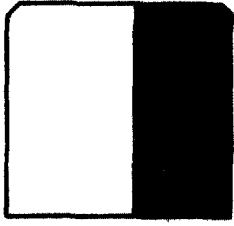

NOTE: REFERENCE DESIGNATIONS ARE ABBREVIATED.  
 PREFIX WITH 1A4.

MX-81-119-IP8-7-2

FIGURE 7-7. BLACK INTERFACE CIRCUIT CARD ASSEMBLY (SHEET 2 OF 2)

| FIG. &<br>INDEX<br>NO. | PART NUMBER               | FSCM  | 1234567 | DESCRIPTION  | UNITS        | USABLE     | SMR<br>CODE |
|------------------------|---------------------------|-------|---------|--|--------------|------------|-------------|
|                        |                           |       |         |  | PER<br>ASSY. | ON<br>CODE |             |
| 7-7-                   | B12117-801                | 37695 |         | CIRCUIT CARD ASSEMBLY, BLACK.<br>INTERFACE (SEE FIGURE 7-2<br>FOR NHA) | REF          |            | PAFLD       |
| -1                     | JANTX1N647-1              | 81349 |         | SEMICONDUCTOR DEVICE.  | 31           |            | PADZZ       |
| -2                     | MS1B-15000HMSPOR<br>M1PCT | 05347 |         | RESISTOR, FIXED WIRE WOUND<br>(MAGNAVOX SPEC CONT DWG<br>238305-1)     | 10           |            | PADZZ       |
| -3                     | JANTX2N3868               | 81349 |         | SEMICONDUCTOR DEVICE.  | 10           |            | PADZZ       |
| -4                     | M8340102M10020B           | 81349 |         | RESISTOR.  | 3            |            | PADZZ       |
| -5                     | 616529-904                | 37695 |         | MICROCIRCUIT, LINEAR   | 2            |            | PADZZ       |
| -6                     | M39014/01-1593            | 81349 |         | CAPACITOR  | 12           |            | PADZZ       |
|                        | *M39014/01-1473           | 81349 |         | CAPACITOR  | 12           |            | PADZZ       |
| -7                     | RCR070105JS               | 81349 |         | RESISTOR.  | 6            |            | PADZZ       |
| -8                     | RCR070393JS               | 81349 |         | RESISTOR.  | 16           |            | PADZZ       |
| -9                     | JANTX1N752A1              | 81349 |         | SEMICONDUCTOR DEVICE.  | 7            |            | PADZZ       |
| -10                    | SE16XC01S                 | 81349 |         | TERMINAL.  | 2            |            | PADZZ       |
| -11                    | RCR070623JS               | 81349 |         | RESISTOR.  | 3            |            | PADZZ       |
| -12                    | 615506-901                | 37695 |         | MICROCIRCUIT, LINEAR   | 3            |            | PADZZ       |
|                        | *M38510/11201BCB          | 81349 |         | MICROCIRCUIT.  | 3            |            | PADZZ       |
|                        | *JM38510/11201BCX         | 81349 |         | MICROCIRCUIT.  | 3            |            | PADZZ       |
| -13                    | 615766-902                | 37695 |         | MICROCIRCUIT.  | 1            |            | PADZZ       |
| -14                    | RCR070203JS               | 81349 |         | RESISTOR.  | 1            |            | PADZZ       |
| -15                    | S-203                     | 18677 |         | EJECTOR, CIRCUIT CARD (MAGNAVOX,<br>SPEC CONT DWG 112781-3)            | 2            |            | XB          |
| -16                    | 616049-902                | 37695 |         | MICROCIRCUIT, DIGITAL.   | 1            |            | PADZZ       |
|                        | *M38510/32002BCB          | 81349 |         | MICROCIRCUIT.  | 1            |            | PADZZ       |
|                        | *JM38510/32002BCX         | 81349 |         | MICROCIRCUIT.  | 1            |            | PADZZ       |
| -17                    | RCR070472JS               | 81349 |         | RESISTOR.  | 2            |            | PADZZ       |
| -18                    | 616049-901                | 37695 |         | MICROCIRCUIT, DIGITAL.   | 1            |            | PADZZ       |
|                        | *JM38510/32001BCX         | 81349 |         | MICROCIRCUIT.  | 1            |            | PADZZ       |
| -19                    | RCR070103JS               | 81349 |         | RESISTOR.  | 2            |            | PADZZ       |
| -20                    | RCR070752JS               | 81349 |         | RESISTOR.  | 1            |            | PADZZ       |
| -21                    | RCR070104JS               | 81349 |         | RESISTOR.  | 3            |            | PADZZ       |
| -22                    | 646197-901                | 37695 |         | MICROCIRCUIT, DIGITAL.   | 1            |            | PADZZ       |
| -23                    | 616031-901                | 37695 |         | MICROCIRCUIT, DIGITAL.   | 1            |            | PADZZ       |
|                        | *M38510/21802BRB          | 81349 |         | MICROCIRCUIT.  | 1            |            | PADZZ       |
|                        | *JM38510/32803BRX         | 81349 |         | MICROCIRCUIT.  | 1            |            | PADZZ       |
| -24                    | M39014/02-1419            | 81349 |         | CAPACITOR  | 1            |            | PADZZ       |
|                        | *M39014/02-1407           | 81349 |         | CAPACITOR  | 1            |            | PADZZ       |
| -25                    | 615660-903                | 37695 |         | MICROCIRCUIT, DIGITAL (ESDS).  | 1            |            | PADZZ       |
| -26                    | 616489-902                | 37695 |         | MICROCIRCUIT, DIGITAL.   | 2            |            | PADZZ       |
| -27                    | M38527/2-05               | 81349 |         | MOUNTING PAD.  | 10           |            | XB          |
| -28                    | M55302/110-16             | 81349 |         | CONNECTOR  | 1            |            | PADZZ       |
| -29                    | MS51957-4                 | 96906 |         | SCREW (AP)   | 2            |            | PADZZ       |
|                        | MS15795-802               | 96906 |         | WASHER (AP)  | 2            |            | PADZZ       |
|                        | M835338-134               | 96906 |         | WASHER (AP)  | 2            |            | PADZZ       |
|                        | NAB671C2                  | 80205 |         | NUT (AP)   | 2            |            | PADZZ       |
| -30                    | M39003/01-3006            | 81349 |         | CAPACITOR  | 1            |            | PADZZ       |
|                        | *M39003/01-2286           | 81349 |         | CAPACITOR  | 1            |            | PADZZ       |
| -31                    | 412042-1                  | 37695 |         | PRINTED WIRING BOARD.  | 1            |            | XB          |

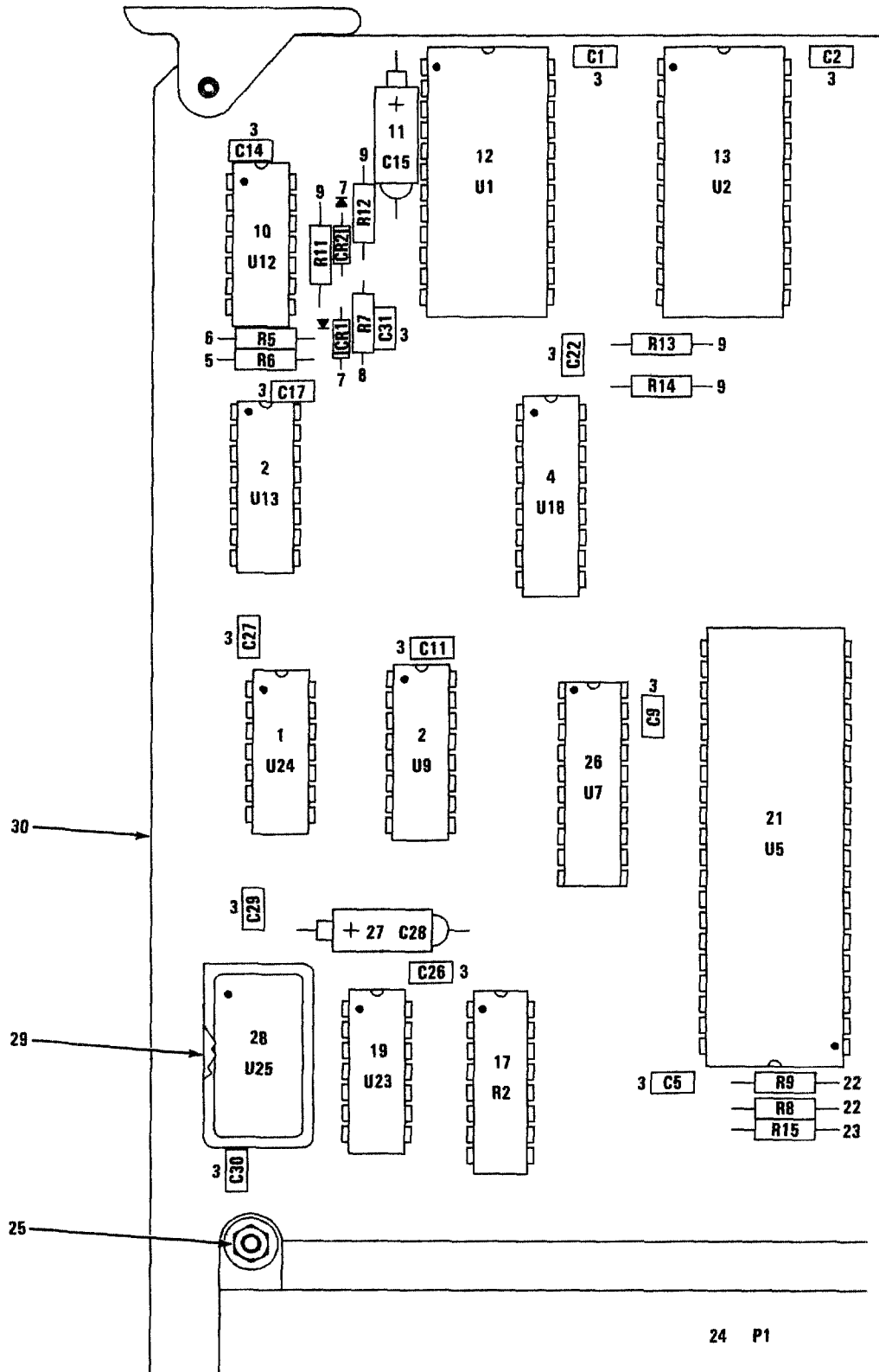
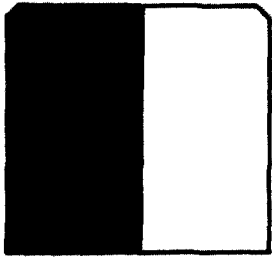

NOTE: REFERENCE DESIGNATIONS ARE ABBREVIATED.  
PREFIX WITH 1A5.

MX-61-119-IPB-8-1  
REF MAG DWG 812116 REV G  
PL 812116 REV AL

FIGURE 7-8. CENTRAL PROCESSING UNIT PRINTED CIRCUIT CARD ASSEMBLY (SHEET 1 OF 2)

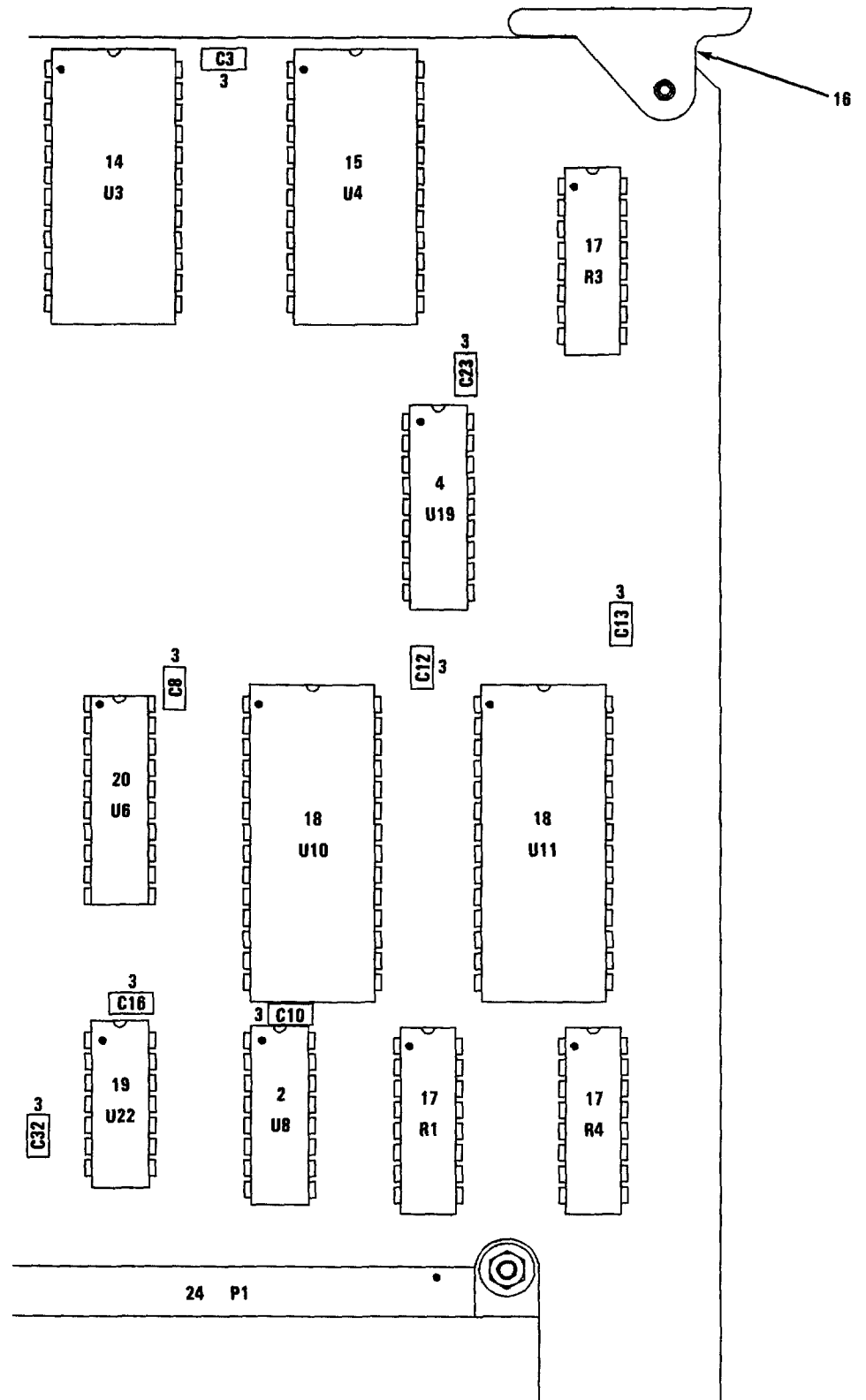
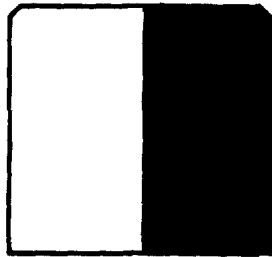

NOTE: REFERENCE DESIGNATIONS ARE ABBREVIATED.  
 PREFIX WITH 1A5.

MX-61-119-IPB-8-2

FIGURE 7-8. CENTRAL PROCESSING UNIT PRINTED CIRCUIT CARD ASSEMBLY (SHEET 2 OF 2)

| FIG. &<br>INDEX<br>NO. | PART NUMBER       | FSCM  | 1234567 | DESCRIPTION   | UNITS<br>PER<br>ASSY. | USABLE<br>ON<br>CODE | SMR<br>CODE |
|------------------------|-------------------|-------|---------|---|-----------------------|----------------------|-------------|
| 7-8-                   | 812116-801        | 37695 |         | CIRCUIT CARD ASSEMBLY, CPU. . . . .<br>(SEE FIGURE 7-2 FOR NHA)         | REF                   |                      | PAFLD       |
| -1                     | 615332-901        | 37695 |         | MICROCIRCUIT, DIGITAL. . . . .  | 1                     |                      | PADZZ       |
|                        | =M38510/30001BCB  | 81349 |         | MICROCIRCUIT. . . . .   | 1                     |                      | PADZZ       |
|                        | *JM38510/30001BCX | 81349 |         | MICROCIRCUIT. . . . .   | 1                     |                      | PADZZ       |
| -2                     | 615279-901        | 37695 |         | MICROCIRCUIT, DIGITAL. . . . .  | 3                     |                      | PADZZ       |
|                        | =M38510/30701BEB  | 81349 |         | MICROCIRCUIT. . . . .   | 3                     |                      | PADZZ       |
|                        | *JM38510/30701BEX | 81349 |         | MICROCIRCUIT. . . . .   | 3                     |                      | PADZZ       |
| -3                     | M39014/01-1593    | 81349 |         | CAPACITOR . . . . .   | 21                    |                      | PADZZ       |
|                        | *M39014/01-1473   | 81349 |         | CAPACITOR . . . . .   | 21                    |                      | PADZZ       |
| -4                     | 616000-902        | 37695 |         | MICROCIRCUIT, DIGITAL (ESDS). . . . .                                   | 2                     |                      | PADZZ       |
|                        | =JM38510/23802BVX | 81349 |         | MICROCIRCUIT (ESDS) . . . . .   | 2                     |                      | PADZZ       |
| -5                     | RCR070392JS       | 81349 |         | RESISTOR. . . . .   | 1                     |                      | PADZZ       |
| -6                     | RCR070243JS       | 81349 |         | RESISTOR. . . . .   | 1                     |                      | PADZZ       |
| -7                     | JANTX1N4454-1     | 81349 |         | SEMICONDUCTOR DEVICE. . . . .   | 2                     |                      | PADZZ       |
| -8                     | RCR070514JS       | 81349 |         | RESISTOR. . . . .   | 1                     |                      | PADZZ       |
| -9                     | RCR070103JS       | 81349 |         | RESISTOR. . . . .   | 4                     |                      | PADZZ       |
| -10                    | 615506-901        | 37695 |         | MICROCIRCUIT, DIGITAL. . . . .  | 1                     |                      | PADZZ       |
|                        | =M38510/11201BCB  | 81349 |         | MICROCIRCUIT. . . . .   | 1                     |                      | PADZZ       |
|                        | *JM38510/11201BCX | 81349 |         | MICROCIRCUIT. . . . .   | 1                     |                      | PADZZ       |
| -11                    | M39003/01-3076    | 81349 |         | CAPACITOR . . . . .   | 1                     |                      | PADZZ       |
|                        | *M39003/01-2356   | 81349 |         | CAPACITOR . . . . .   | 1                     |                      | PADZZ       |
| -12                    | 646316-901        | 37695 |         | MICROCIRCUIT, DIGITAL (ESDS) . . . . .                                  | 1                     |                      | PADZZ       |
| -13                    | 646317-901        | 37695 |         | MICROCIRCUIT, DIGITAL (ESDS) . . . . .                                  | 1                     |                      | PADZZ       |
| -14                    | 646318-901        | 37695 |         | MICROCIRCUIT, DIGITAL (ESDS) . . . . .                                  | 1                     |                      | PADZZ       |
| -15                    | 646319-901        | 37695 |         | MICROCIRCUIT, DIGITAL (ESDS) . . . . .                                  | 1                     |                      | PADZZ       |
| -16                    | B-203             | 18677 |         | EJECTOR, CIRCUIT CARD (MAGNAVOX.<br>SPEC CONT DWG 112781-3)             | 2                     |                      | XB          |
| -17                    | M8340102M1002GB   | 81349 |         | RESISTOR. . . . .   | 4                     |                      | PADZZ       |
| -18                    | 616486-904        | 37695 |         | MICROCIRCUIT, DIGITAL (ESDS) . . . . .                                  | 2                     |                      | PADZZ       |
| -19                    | 615331-901        | 37695 |         | MICROCIRCUIT. . . . .   | 2                     |                      | PADZZ       |
|                        | =M38510/30003BCB  | 81349 |         | MICROCIRCUIT. . . . .   | 2                     |                      | PADZZ       |
| -20                    | 615797-903        | 37695 |         | MICROCIRCUIT, DIGITAL. . . . .  | 1                     |                      | PADZZ       |
|                        | =M38510/32502BRB  | 81349 |         | MICROCIRCUIT. . . . .   | 1                     |                      | PADZZ       |
|                        | *JM38510/32502BRX | 81349 |         | MICROCIRCUIT. . . . .   | 1                     |                      | PADZZ       |
| -21                    | 7901001GX         | 14933 |         | MICROCIRCUIT, DIGITAL (MAGNAVOX.<br>SPEC CONT DWG 616484-902)<br>(ESDS) | 1                     |                      | PADZZ       |
| -22                    | RCR070471JS       | 81349 |         | RESISTOR. . . . .   | 2                     |                      | PADZZ       |
| -23                    | RCR070102JS       | 81349 |         | RESISTOR. . . . .   | 1                     |                      | PADZZ       |
| -24                    | M55302/110-16     | 81349 |         | CONNECTOR . . . . .   | 1                     |                      | PADZZ       |
| -25                    | M851957-4         | 96906 |         | SCREW (AP). . . . .   | 2                     |                      | PADZZ       |
|                        | M815795-802       | 96906 |         | WASHER (AP) . . . . .   | 2                     |                      | PADZZ       |
|                        | M835338-134       | 96906 |         | WASHER (AP) . . . . .   | 2                     |                      | PADZZ       |
|                        | NA8671C2          | 80205 |         | NUT (AP). . . . .   | 2                     |                      | PADZZ       |
| -26                    | 615796-901        | 37695 |         | MICROCIRCUIT, DIGITAL. . . . .  | 1                     |                      | PADZZ       |
|                        | =M38510/32403BRB  | 81349 |         | MICROCIRCUIT. . . . .   | 1                     |                      | PADZZ       |
|                        | *JM38510/32403BRX | 81349 |         | MICROCIRCUIT. . . . .   | 1                     |                      | PADZZ       |
| -27                    | M39003/01-3006    | 81349 |         | CAPACITOR . . . . .   | 1                     |                      | PADZZ       |
|                        | *M39003/01-2286   | 81349 |         | CAPACITOR . . . . .   | 1                     |                      | PADZZ       |
| -28                    | T113-4 MHZ        | 57051 |         | OSCILLATOR, CRYSTAL (MAGNAVOX.<br>SPEC CONT DWG 626724-1)               | 1                     |                      | PADZZ       |
| -29                    | 348559-1          | 37695 |         | INSULATOR, OSCILLATOR. . . . .  | 1                     |                      | XB          |
| -30                    | 412041-1          | 37695 |         | PRINTED CIRCUIT BOARD . . . . .   | 1                     |                      | XB          |

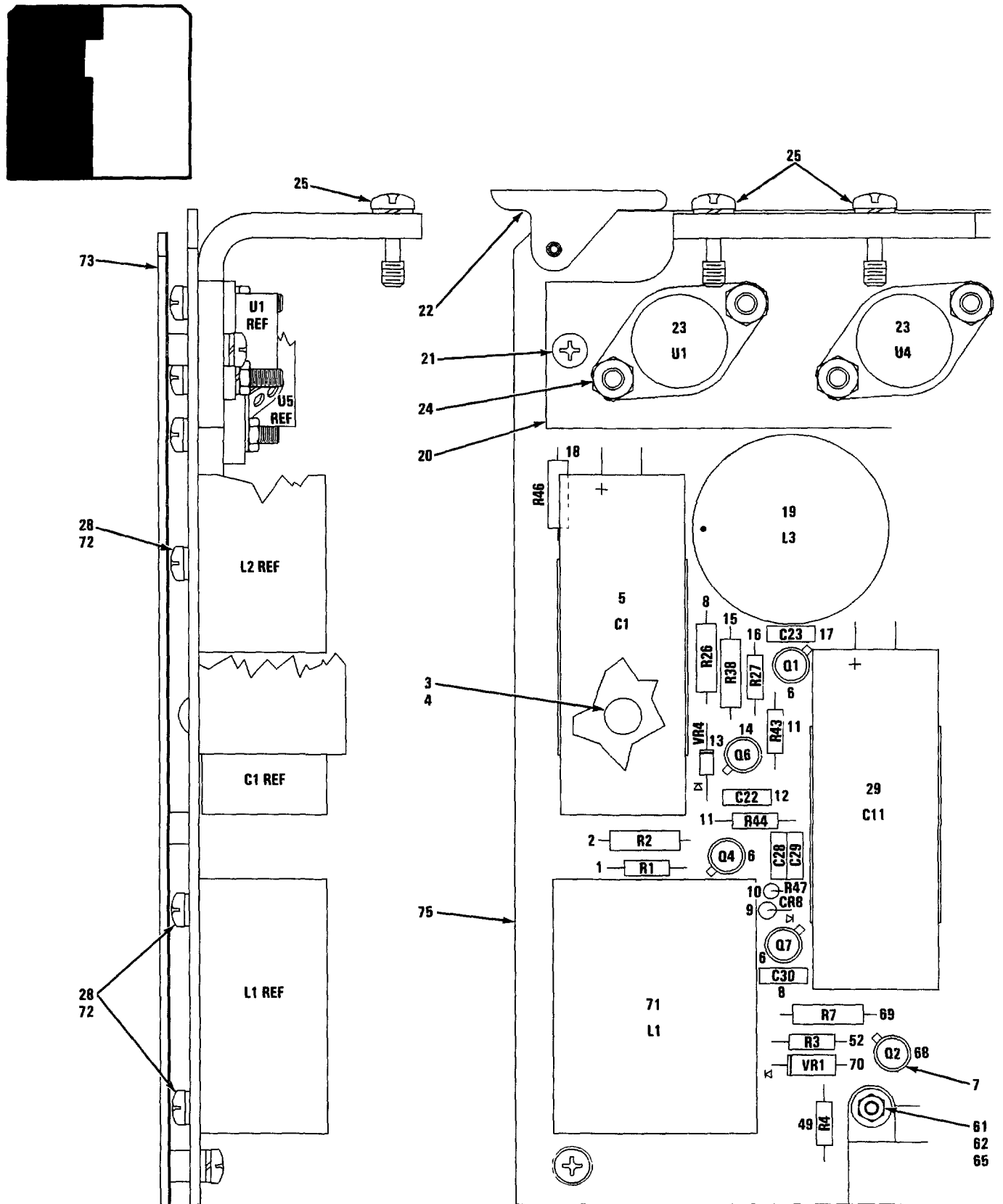

NOTE: REFERENCE DESIGNATIONS ARE ABBREVIATED.  
PREFIX WITH 1A6.

MX-61-119-IPB-9-1  
REF MAG DWG 812122 REV J  
PL 812122 REV R

FIGURE 7-9. POWER SUPPLY SUBASSEMBLY (SHEET 1 OF 2)

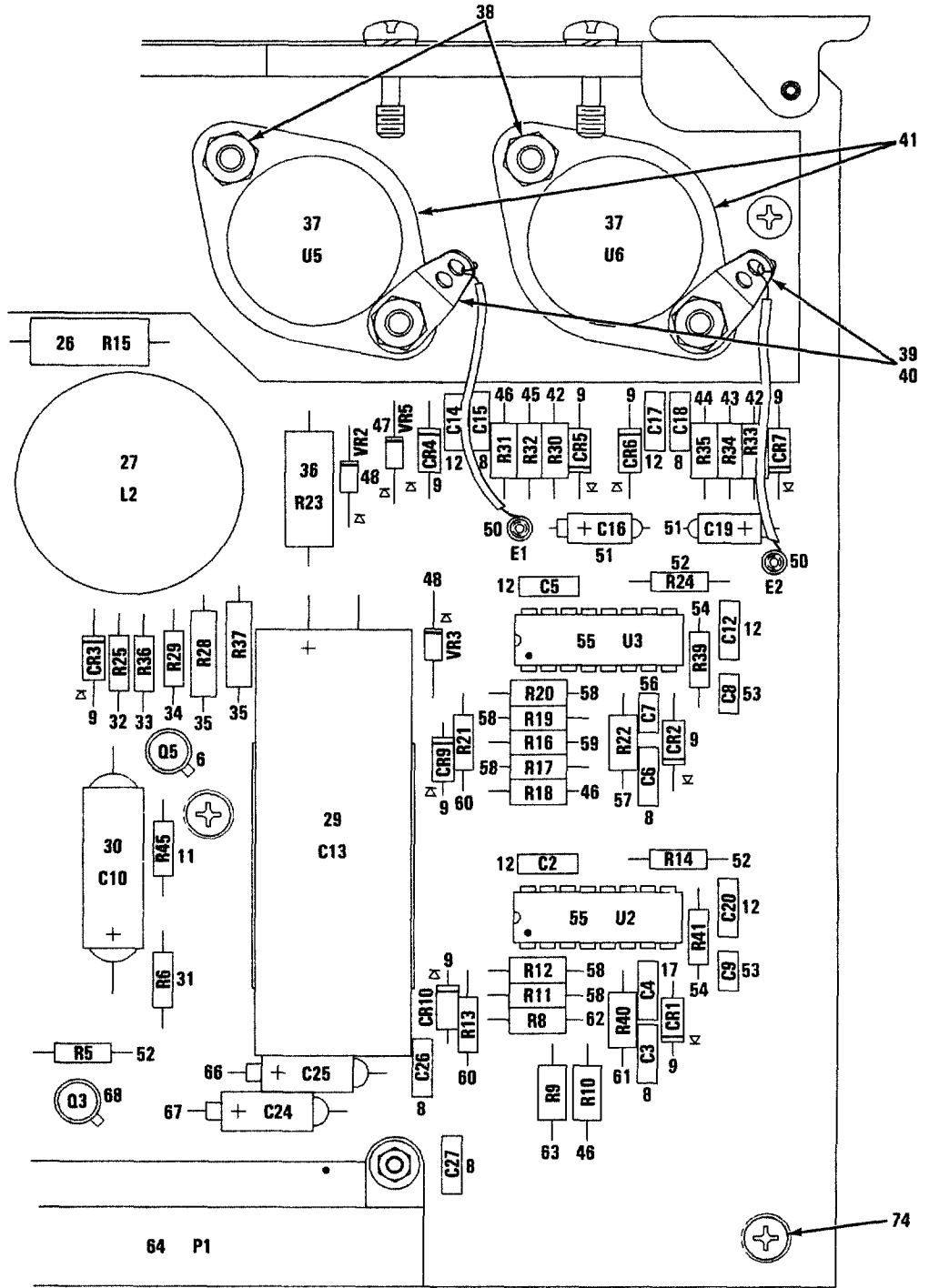
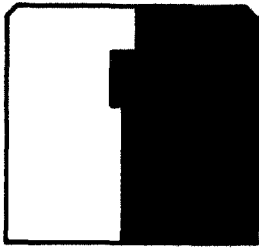

NOTE: REFERENCE DESIGNATIONS ARE ABBREVIATED.  
 PREFIX WITH 1A6.

MX-61-119-IPB-9-2

FIGURE 7-9. POWER SUPPLY SUBASSEMBLY (SHEET 2 OF 2)



| FIG. &<br>INDEX<br>NUMBER | PART NUMBER        | FSCM  | DESCRIPTION   |   |   |   |   |   |   | UNITS<br>PER<br>ASSY | USABLE<br>ON<br>CODE | SMR<br>CODE |
|---------------------------|--------------------|-------|---|---|---|---|---|---|---|----------------------|----------------------|-------------|
|                           |                    |       | 1   | 2 | 3 | 4 | 5 | 6 | 7 |                      |                      |             |
| 7-9-                      | 812122-801         | 37695 | POWER SUPPLY SUBASSEMBLY . . . . .<br>(SEE FIGURE 7-2 FOR NHA)                  |   |   |   |   |   |   | REF                  |                      | PADLD       |
| -1                        | RCR07G822JS        | 81349 | . RESISTOR . . . . .  |   |   |   |   |   |   | 1                    |                      | PADZZ       |
| -2                        | RWR80S2001FM       | 81349 | . RESISTOR . . . . .  |   |   |   |   |   |   | 1                    |                      | PADZZ       |
| -3                        | 100-300-12-8       | 99378 | . CLIP, SPRING TENSION (MAGNAVOX SPEC . . . . .<br>CONT DWG 107306-16)          |   |   |   |   |   |   | 3                    |                      | XB          |
| -4                        | MS16535-133        | 96906 | . RIVET (AP) . . . . .  |   |   |   |   |   |   | 2                    |                      | XB          |
| -5                        | 3428GL561T050RMA3  | 99392 | . CAPACITOR, FIXED, ELECTROLYTIC . . . . .<br>(MAGNAVOX SPEC CONT DWG 275104-2) |   |   |   |   |   |   | 1                    |                      | PADZZ       |
| -6                        | JANTX2N2907A       | 81349 | . SEMICONDUCTOR DEVICE . . . . .  |   |   |   |   |   |   | 4                    |                      | PADZZ       |
| -7                        | 7717-7N-WHITE      | 13103 | . INSULATOR, TRANSISTOR (MAGNAVOX . . . . .<br>SPEC CONT DWG 447279-102)        |   |   |   |   |   |   | 7                    |                      | PADZZ       |
| -8                        | M39014/02-1419     | 81349 | . CAPACITOR . . . . .   |   |   |   |   |   |   | 9                    |                      | PADZZ       |
|                           | * M39014/02-1407   | 81349 | . CAPACITOR . . . . .   |   |   |   |   |   |   | 9                    |                      | PADZZ       |
| -9                        | JANTX1N5615        | 81349 | . SEMICONDUCTOR DEVICE . . . . .  |   |   |   |   |   |   | 10                   |                      | PADZZ       |
| -10                       | RCR07G244JS        | 81349 | . RESISTOR . . . . .  |   |   |   |   |   |   | 1                    |                      | PADZZ       |
| -11                       | RCR07G101JS        | 81349 | . RESISTOR . . . . .  |   |   |   |   |   |   | 3                    |                      | PADZZ       |
| -12                       | M39014/02-1350     | 81349 | . CAPACITOR . . . . .   |   |   |   |   |   |   | 7                    |                      | PADZZ       |
|                           | * M39014/02-1230   | 81349 | . CAPACITOR . . . . .   |   |   |   |   |   |   | 7                    |                      | PADZZ       |
| -13                       | JANTX1N4954        | 81349 | . SEMICONDUCTOR DEVICE . . . . .  |   |   |   |   |   |   | 1                    |                      | PADZZ       |
| -14                       | JANTX2N3029        | 81349 | . SEMICONDUCTOR DEVICE (MAGNAVOX . . . . .<br>SPEC CONT DWG 615949-1)           |   |   |   |   |   |   | 1                    |                      | PADZZ       |
| -15                       | RWR80SR243FM       | 81349 | . RESISTOR . . . . .  |   |   |   |   |   |   | 2                    |                      | PADZZ       |
| -16                       | RCR07G102JS        | 81349 | . RESISTOR . . . . .  |   |   |   |   |   |   | 1                    |                      | PADZZ       |
| -17                       | M39014/02-1388     | 81349 | . CAPACITOR . . . . .   |   |   |   |   |   |   | 2                    |                      | PADZZ       |
|                           | * M39014/02-1218   | 81349 | . CAPACITOR . . . . .   |   |   |   |   |   |   | 2                    |                      | PADZZ       |
| -18                       | RWR80S1501FM       | 81349 | . RESISTOR . . . . .  |   |   |   |   |   |   | 1                    |                      | PADZZ       |
| -19                       | 325323-1           | 37695 | . REACTOR, POWER, DUAL SECTION. . . . .   |   |   |   |   |   |   | 1                    |                      | PADZZ       |
| -20                       | 435664-1           | 37695 | . HEATSINK, POWER SUPPLY . . . . .  |   |   |   |   |   |   | 1                    |                      | XB          |
| -21                       | MS51957-16         | 96906 | . SCREW (AP). . . . .   |   |   |   |   |   |   | 2                    |                      | PADZZ       |
|                           | NAS620C4           | 80205 | . WASHER (AP) . . . . .   |   |   |   |   |   |   | 2                    |                      | PADZZ       |
|                           | MS35338-135        | 96906 | . WASHER (AP) . . . . .   |   |   |   |   |   |   | 2                    |                      | PADZZ       |
| -22                       | S-203              | 18677 | . EJECTOR, CIRCUIT CARD (MAGNAVOX . . . . .<br>SPEC CONT DWG 112781-3)          |   |   |   |   |   |   | 2                    |                      | XB          |
| -23                       | 646272-901         | 37695 | . SEMICONDUCTOR DEVICE, HYBRID . . . . .<br>SWITCHING REGULATOR                 |   |   |   |   |   |   | 2                    |                      | PADZZ       |
| -24                       | MS51957-18         | 96906 | . SCREW (AP). . . . .   |   |   |   |   |   |   | 2                    |                      | PADZZ       |
|                           | NAS620C4           | 80205 | . WASHER (AP) . . . . .   |   |   |   |   |   |   | 2                    |                      | PADZZ       |
|                           | MS35338-135        | 96906 | . WASHER (AP) . . . . .   |   |   |   |   |   |   | 2                    |                      | PADZZ       |
| -25                       | 136555-1           | 37695 | . SCREW, MODIFIED . . . . .   |   |   |   |   |   |   | 4                    |                      | PADZZ       |
|                           | MS35338-136        | 96906 | . WASHER. . . . .   |   |   |   |   |   |   | 4                    |                      | PADZZ       |
| -26                       | RCR32G751JS        | 81349 | . RESISTOR . . . . .  |   |   |   |   |   |   | 1                    |                      | PADZZ       |
| -27                       | 325322-1           | 37695 | . REACTOR, POWER . . . . .  |   |   |   |   |   |   | 1                    |                      | PADZZ       |
| -28                       | MS51957-13         | 96906 | . SCREW (AP). . . . .   |   |   |   |   |   |   | 2                    |                      | PADZZ       |
|                           | NAS620C4           | 80205 | . WASHER (AP) . . . . .   |   |   |   |   |   |   | 2                    |                      | PADZZ       |
| -29                       | 3428GL721V050RMA3  | 99392 | . CAPACITOR, FIXED, ELECTROLYTIC . . . . .<br>(MAGNAVOX SPEC CONT DWG 275104-3) |   |   |   |   |   |   | 1                    |                      | PADZZ       |
| -30                       | M39018/01-0655     | 81349 | . CAPACITOR . . . . .   |   |   |   |   |   |   | 1                    |                      | PADZZ       |
|                           | = M39018/01-0653   | 81349 | . CAPACITOR . . . . .   |   |   |   |   |   |   | 1                    |                      | PADZZ       |
| -31                       | RCR07G332JS        | 81349 | . RESISTOR . . . . .  |   |   |   |   |   |   | 1                    |                      | PADZZ       |
| -32                       | RCR07G100JS        | 81349 | . RESISTOR . . . . .  |   |   |   |   |   |   | 1                    |                      | PADZZ       |
| -33                       | RCR07G752JS        | 81349 | . RESISTOR . . . . .  |   |   |   |   |   |   | 1                    |                      | PADZZ       |
| -34                       | RCR07G432JS        | 81349 | . RESISTOR . . . . .  |   |   |   |   |   |   | 1                    |                      | PADZZ       |
| -35                       | RWR80SR200FM       | 81349 | . RESISTOR . . . . .  |   |   |   |   |   |   | 2                    |                      | PADZZ       |
| -36                       | RCR32G511JS        | 81349 | . RESISTOR . . . . .  |   |   |   |   |   |   | 1                    |                      | PADZZ       |
| -37                       | 615883-902         | 37695 | . MICROCIRCUIT, LINEAR . . . . .  |   |   |   |   |   |   | 2                    |                      | PADZZ       |
|                           | = JM38510/11704BYX | 81349 | . MICROCIRCUIT . . . . .  |   |   |   |   |   |   | 2                    |                      | PADZZ       |
| -38                       | MS51957-18         | 96906 | . SCREW (AP). . . . .   |   |   |   |   |   |   | 1                    |                      | PADZZ       |
|                           | 107240-30          | 37695 | . WASHER, NONMETALLIC (AP). . . . .   |   |   |   |   |   |   | 1                    |                      | PADZZ       |
|                           | NAS620C4           | 80205 | . WASHER (AP) . . . . .   |   |   |   |   |   |   | 1                    |                      | PADZZ       |
|                           | MS35338-135        | 96906 | . WASHER (AP) . . . . .   |   |   |   |   |   |   | 1                    |                      | PADZZ       |
|                           | NAS671C4           | 80205 | . NUT (AP). . . . .   |   |   |   |   |   |   | 1                    |                      | PADZZ       |
| -39                       | MS51957-18         | 96906 | . SCREW (AP). . . . .   |   |   |   |   |   |   | 1                    |                      | PADZZ       |
|                           | 107240-30          | 37695 | . WASHER, NONMETALLIC (AP). . . . .   |   |   |   |   |   |   | 1                    |                      | PADZZ       |
|                           | NAS620C4           | 80205 | . WASHER (AP) . . . . .   |   |   |   |   |   |   | 1                    |                      | PADZZ       |
|                           | NAS671C4           | 80205 | . NUT (AP). . . . .   |   |   |   |   |   |   | 1                    |                      | PADZZ       |
| -40                       | MS77068-1          | 96906 | . TERMINAL . . . . .  |   |   |   |   |   |   | 2                    |                      | PADZZ       |

| FIG. & INDEX NO. | PART NUMBER      | FSCM  | 1234567 | DESCRIPTION   | UNITS PER ASSY. | USABLE ON CODE | SMR CODE |
|------------------|------------------|-------|---------|---|-----------------|----------------|----------|
| 7-9-41           | 60-11-4305-1674  | 18565 |         | INSULATOR, TRANSISTOR (MAGNAVOX. . .<br>SPEC CONT DWG 347705-301) | 2               |                | XB       |
| -42              | RNC55H2430FM     | 81349 |         | RESISTOR. . . . .   | 2               |                | PADZZ    |
| -43              | RNC55H2491FM     | 81349 |         | RESISTOR. . . . .   | 1               |                | PADZZ    |
| -44              | +RNC55H1372FM    | 81349 |         | RESISTOR. . . . .   | 1               |                | PADZZ    |
|                  | +RNC55H1182FM    | 81349 |         | RESISTOR. . . . .   | 1               |                | PADZZ    |
|                  | +RNC55H1212FM    | 81349 |         | RESISTOR. . . . .   | 1               |                | PADZZ    |
|                  | +RNC55H1242FM    | 81349 |         | RESISTOR. . . . .   | 1               |                | PADZZ    |
|                  | +RNC55H1272      | 81349 |         | RESISTOR. . . . .   | 1               |                | PADZZ    |
|                  | +RNC55H1302FM    | 81349 |         | RESISTOR. . . . .   | 1               |                | PADZZ    |
|                  | +RNC55H1332FM    | 81349 |         | RESISTOR. . . . .   | 1               |                | PADZZ    |
|                  | +RNC55H1402FM    | 81349 |         | RESISTOR. . . . .   | 1               |                | PADZZ    |
|                  | +RNC55H1432FM    | 81349 |         | RESISTOR. . . . .   | 1               |                | PADZZ    |
|                  | +RNC55H1472FM    | 81349 |         | RESISTOR. . . . .   | 1               |                | PADZZ    |
|                  | +RNC55H1502FM    | 81349 |         | RESISTOR. . . . .   | 1               |                | PADZZ    |
|                  | +RNC55H1542FM    | 81349 |         | RESISTOR. . . . .   | 1               |                | PADZZ    |
| -45              | RNC55H2001FM     | 81349 |         | RESISTOR. . . . .   | 1               |                | PADZZ    |
| -46              | +RNC55H6191FM    | 81349 |         | RESISTOR. . . . .   | 3               |                | PADZZ    |
|                  | +RNC55H5761FM    | 81349 |         | RESISTOR. . . . .   | 3               |                | PADZZ    |
|                  | +RNC55H5901FM    | 81349 |         | RESISTOR. . . . .   | 3               |                | PADZZ    |
|                  | +RNC55H6041FM    | 81349 |         | RESISTOR. . . . .   | 3               |                | PADZZ    |
|                  | +RNC55H6341FM    | 81349 |         | RESISTOR. . . . .   | 3               |                | PADZZ    |
|                  | +RNC55H6491FM    | 81349 |         | RESISTOR. . . . .   | 3               |                | PADZZ    |
|                  | +RNC55H6651FM    | 81349 |         | RESISTOR. . . . .   | 3               |                | PADZZ    |
|                  | +RNC55H6811FM    | 81349 |         | RESISTOR. . . . .   | 3               |                | PADZZ    |
|                  | +RNC55H6981FM    | 81349 |         | RESISTOR. . . . .   | 3               |                | PADZZ    |
|                  | +RNC55H7151FM    | 81349 |         | RESISTOR. . . . .   | 3               |                | PADZZ    |
|                  | +RNC55H7321FM    | 81349 |         | RESISTOR. . . . .   | 3               |                | PADZZ    |
| -47              | JANTX1N4472      | 81349 |         | SEMICONDUCTOR DEVICE.   | 1               |                | PADZZ    |
| -48              | JANTX1N4465      | 81349 |         | SEMICONDUCTOR DEVICE.   | 2               |                | PADZZ    |
| -49              | RCR070123JS      | 81349 |         | RESISTOR. . . . .   | 1               |                | PADZZ    |
| -50              | SE16XC01S        | 81349 |         | TERMINAL, STUD . . . . .  | 2               |                | PADZZ    |
| -51              | M39003/01-3076   | 81349 |         | CAPACITOR . . . . .   | 2               |                | PADZZ    |
|                  | *M39003/01-2116  | 81349 |         | CAPACITOR . . . . .   | 2               |                | PADZZ    |
| -52              | RCR070103JS      | 81349 |         | RESISTOR. . . . .   | 4               |                | PADZZ    |
| -53              | M39014/01-1351   | 81349 |         | CAPACITOR . . . . .   | 2               |                | PADZZ    |
|                  | *M39014/01-1231  | 81349 |         | CAPACITOR . . . . .   | 2               |                | PADZZ    |
| -54              | RCR070204JS      | 81349 |         | RESISTOR. . . . .   | 2               |                | PADZZ    |
| -55              | JM38510/12601BEX | 81349 |         | MICROCIRCUIT (MAGNAVOX SPEC<br>CONT DWG 61649B-901)               | 2               |                | PADZZ    |
| -56              | M39014/01-1574   | 81349 |         | CAPACITOR . . . . .   | 1               |                | PADZZ    |
|                  | *M39014/01-1451  | 81349 |         | CAPACITOR . . . . .   | 1               |                | PADZZ    |
| -57              | RNC55H5621FM     | 81349 |         | RESISTOR. . . . .   | 1               |                | PADZZ    |
| -58              | RNC55H4991FM     | 81349 |         | RESISTOR. . . . .   | 5               |                | PADZZ    |
| -59              | RNC55H3011FM     | 81349 |         | RESISTOR. . . . .   | 1               |                | PADZZ    |
| -60              | RCR070304JS      | 81349 |         | RESISTOR. . . . .   | 2               |                | PADZZ    |
| -61              | RNC55H5111FM     | 81349 |         | RESISTOR. . . . .   | 1               |                | PADZZ    |
| -62              | RNC55H2432FM     | 81349 |         | RESISTOR. . . . .   | 1               |                | PADZZ    |
| -63              | RNC55H1002FM     | 81349 |         | RESISTOR. . . . .   | 1               |                | PADZZ    |
| -64              | M55302/110-10    | 81349 |         | CONNECTOR . . . . .   | 1               |                | PADZZ    |
| -65              | MS51957-4        | 96906 |         | SCREW (AP). . . . .   | 2               |                | PADZZ    |
|                  | MS35338-134      | 96906 |         | WASHER (AP) . . . . .   | 2               |                | PADZZ    |
|                  | MS15795-802      | 96906 |         | WASHER (AP) . . . . .   | 2               |                | PADZZ    |
|                  | NAS671C2         | 80205 |         | NUT (AP). . . . .   | 2               |                | PADZZ    |
| -66              | M39003/01-3024   | 81349 |         | CAPACITOR . . . . .   | 1               |                | PADZZ    |
|                  | *M39003/01-2304  | 81349 |         | CAPACITOR . . . . .   | 1               |                | PADZZ    |
| -67              | M39003/01-3005   | 81349 |         | CAPACITOR . . . . .   | 1               |                | PADZZ    |
|                  | *M39003/01-2285  | 81349 |         | CAPACITOR . . . . .   | 1               |                | PADZZ    |
| -68              | JANTX2N2222A     | 81349 |         | SEMICONDUCTOR DEVICE.   | 2               |                | PADZZ    |
| -69              | RWR80S2741FM     | 81349 |         | RESISTOR. . . . .   | 1               |                | PADZZ    |
| -70              | JANTX1N4471      | 81349 |         | SEMICONDUCTOR DEVICE.   | 1               |                | PADZZ    |
|                  | =JANTX1N967B     | 81349 |         | SEMICONDUCTOR DEVICE.   | 1               |                | PADZZ    |
| -71              | 325324-1         | 37695 |         | REACTOR, POWER . . . . .  | 1               |                | PADZZ    |
| -72              | MS51957-13       | 96906 |         | SCREW (AP). . . . .   | 2               |                | PADZZ    |
|                  | NAS620C4         | 80205 |         | WASHER (AP) . . . . .   | 2               |                | PADZZ    |
| -73              | 939139-801       | 37695 |         | SHIELD, POWER ASSEMBLY . . . . .                                  | 1               |                | XB       |
| -74              | MS51957-13       | 96906 |         | SCREW (AP). . . . .   | 3               |                | PADZZ    |
|                  | NAS620C4         | 80205 |         | WASHER (AP) . . . . .   | 3               |                | PADZZ    |
|                  | MS35338-135      | 96906 |         | WASHER (AP) . . . . .   | 3               |                | PADZZ    |

| FIG. &<br>INDEX<br>ND. | PART NUMBER | FSCM 1234567 | DESCRIPTION                    | UNITS PER<br>ASSY. | USABLE<br>ON<br>CODE | SMR<br>CODE |
|------------------------|-------------|--------------|--------------------------------|--------------------|----------------------|-------------|
| 7-9-75                 | 412043-1    | 37695        | .PRINTED WIRING BOARD. . . . . | 1                  |                      | XB          |

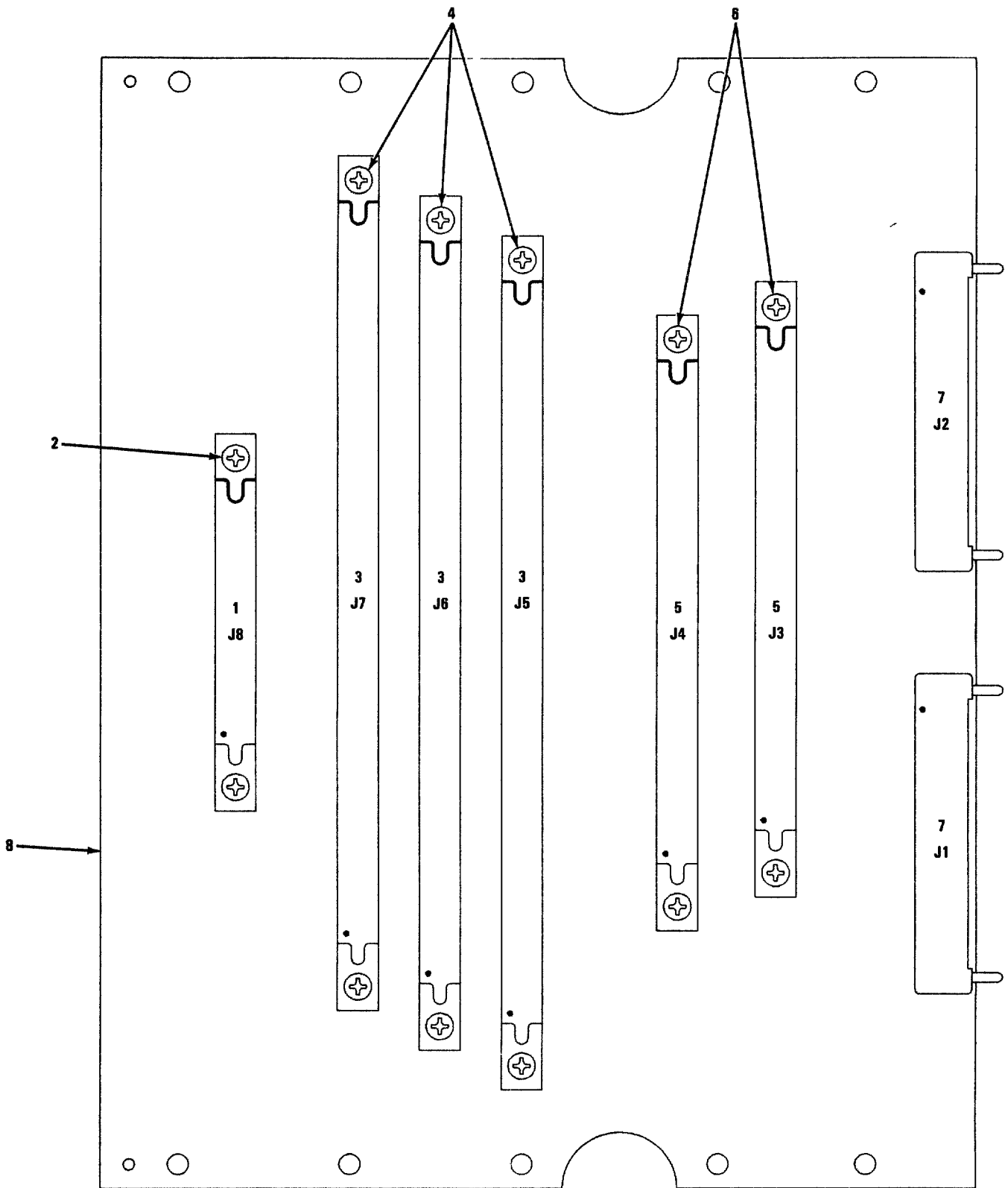

NOTE: REFERENCE DESIGNATIONS ARE ABBREVIATED  
PREFIX WITH 1A7.

MX-61-119-1PB-10  
REF MAG DWG 812129 REV D  
PL 812129 REV C

FIGURE 7-10. BACKPLANE ASSEMBLY

| FIGURE<br>& INDEX<br>NUMBER | PART<br>NUMBER | FSCM  | DESCRIPTION<br>1 2 3 4 5 6 7                         | UNITS<br>PER<br>ASSY | USABLE<br>ON<br>CODE | SMR<br>CODE |
|-----------------------------|----------------|-------|--|----------------------|----------------------|-------------|
|                             |                |       |  |                      |                      |             |
| 7-10-                       | 812129-801     | 37695 | BACKPLANE ASSEMBLY (SEE FIGURE 7-2 .....<br>FOR NHA) | REF                  |                      | XB          |
| -1                          | M55302/27-91   | 81349 | . CONNECTOR.....                                     | 1                    |                      | XB          |
| -2                          | MS51957-4      | 96906 | . SCREW (AP).....                                    | 2                    |                      | PAFZZ       |
|                             | NAS620C2       | 80205 | . WASHER (AP).....                                   | 2                    |                      | PAFZZ       |
|                             | MS35338-134    | 96906 | . WASHER (AP).....                                   | 2                    |                      | PAFZZ       |
|                             | NAS671C2       | 80205 | . NUT (AP).....                                      | 2                    |                      | PAFZZ       |
| -3                          | M55302/27-97   | 81349 | . CONNECTOR.....                                     | 3                    |                      | XB          |
| -4                          | MS51957-4      | 96906 | . SCREW (AP).....                                    | 2                    |                      | PAFZZ       |
|                             | NAS620C2       | 80205 | . WASHER (AP).....                                   | 2                    |                      | PAFZZ       |
|                             | MS35338-134    | 96906 | . WASHER (AP).....                                   | 2                    |                      | PAFZZ       |
|                             | NAS671C2       | 80205 | . NUT (AP).....                                      | 2                    |                      | PAFZZ       |
| -5                          | M55302/27-94   | 81349 | . CONNECTOR.....                                     | 2                    |                      | XB          |
| -6                          | MS51957-4      | 96906 | . SCREW (AP).....                                    | 2                    |                      | PAFZZ       |
|                             | NAS620C2       | 80205 | . WASHER (AP).....                                   | 2                    |                      | PAFZZ       |
|                             | MS35338-134    | 96906 | . WASHER (AP).....                                   | 2                    |                      | PAFZZ       |
|                             | NAS671C2       | 80205 | . NUT (AP).....                                      | 2                    |                      | PAFZZ       |
| -7                          | M55302/7-04    | 81349 | . CONNECTOR.....                                     | 2                    |                      | XB          |
| -8                          | 412051-1       | 37695 | . PRINTED WIRING BOARD .....                         | 1                    |                      | XB          |

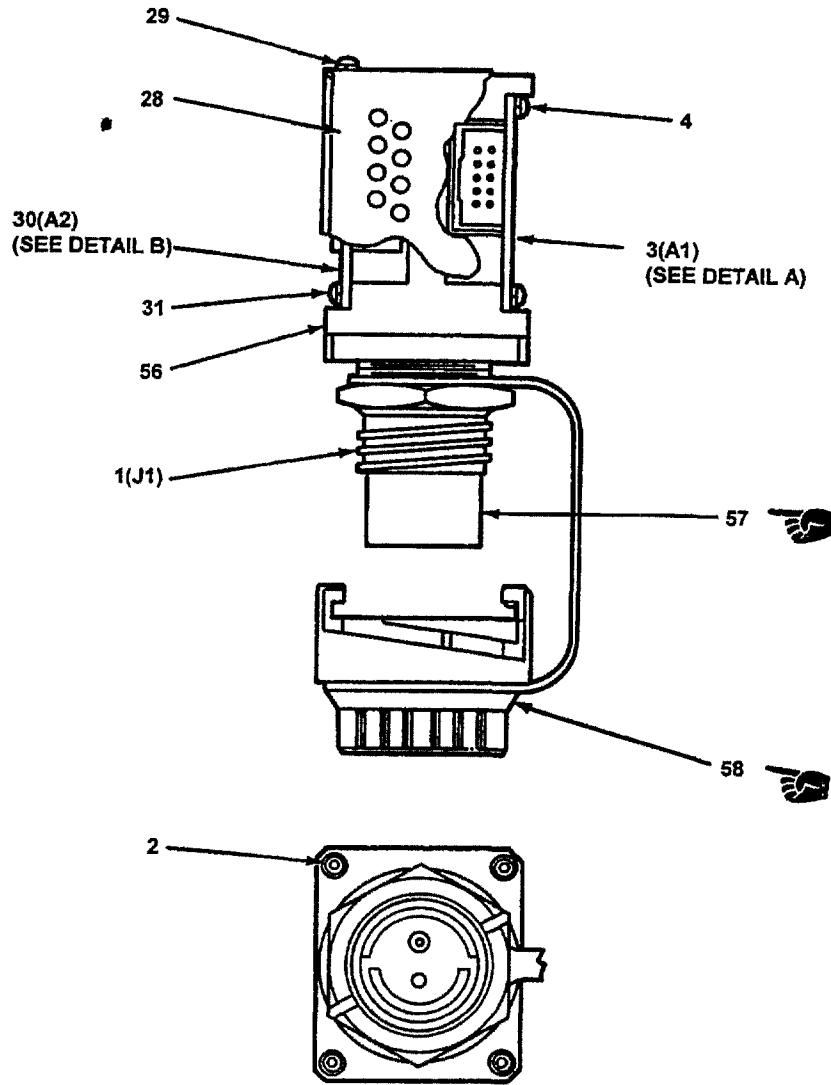

NOTE: REFERENCE DESIGNATIONS ARE ABBREVIATED  
PREFIX WITH 1A8, 1A9, 5A1A4, 6A1A4.

MX-81-119-IPB-11-1  
REF MAG DWG 812099 REV D  
PL 812099 REV N

FIGURE 7-11. FIBER OPTIC MODULE ASSEMBLY (SHEET 1 OF 3)

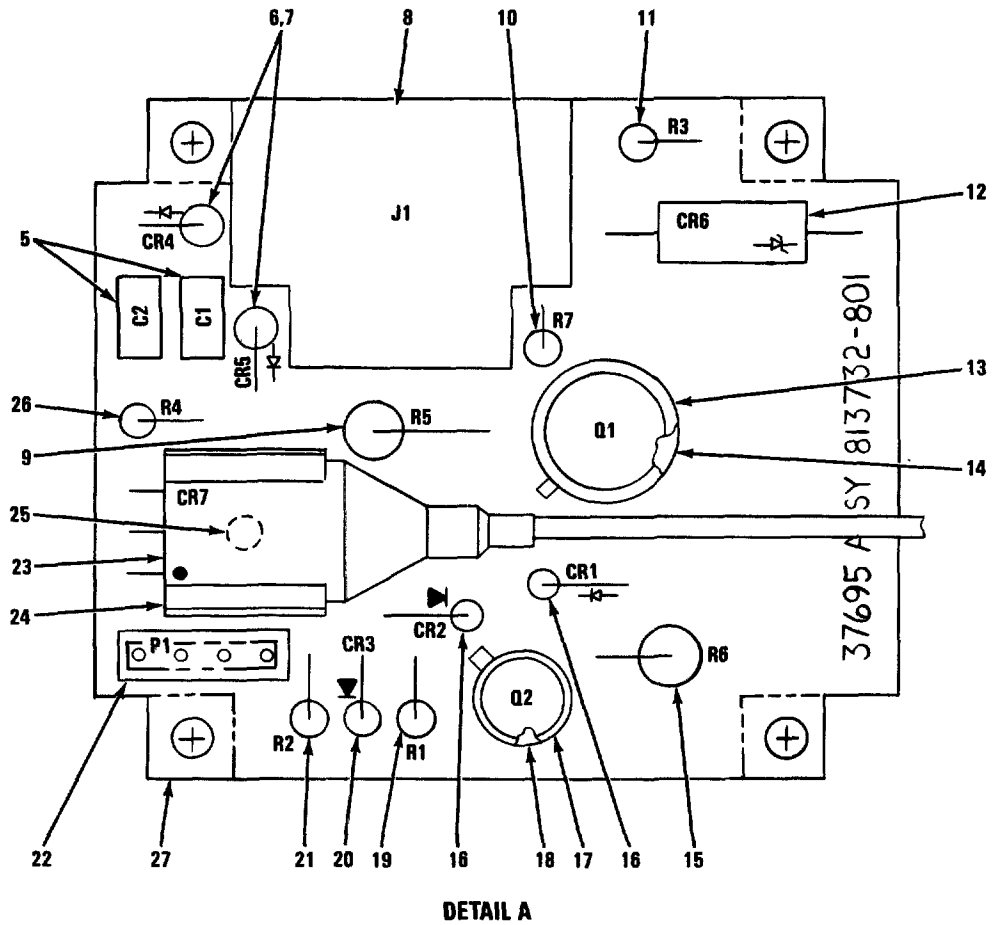

**NOTE: REFERENCE DESIGNATIONS ARE ABBREVIATED  
 PREFIX WITH 1A8A1, 1A9A1, 5A1A4A1, 6A1A4A1.**

**MX-61-119-IPB-11-2**

**FIGURE 7-11. FIBER OPTIC MODULE ASSEMBLY (SHEET 2 OF 3)**

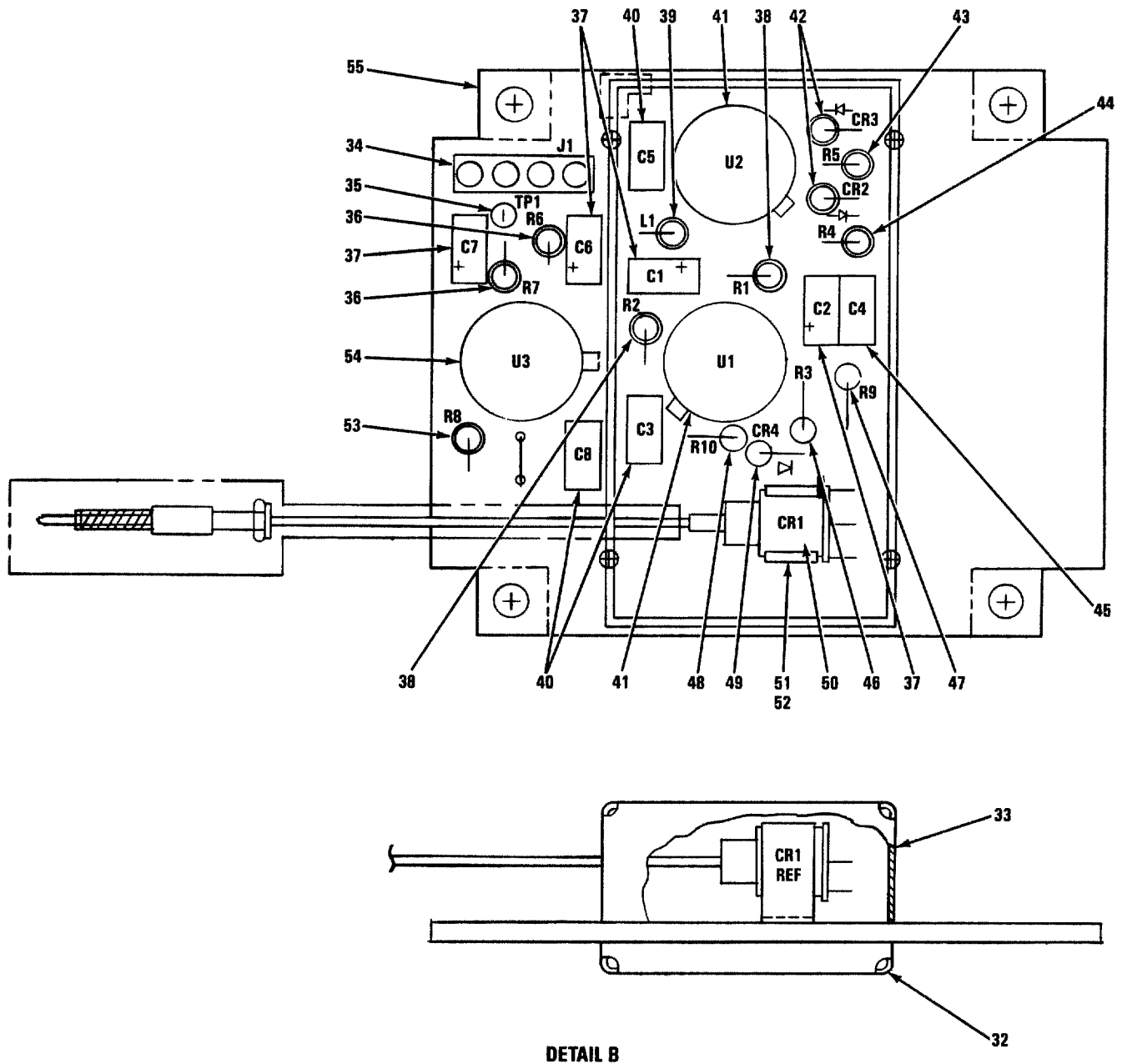

NOTE: REFERENCE DESIGNATIONS ARE ABBREVIATED  
 PREFIX WITH 1A8A2, 1A9A2, 5A1A4A2, 6A1A4A2.

MX-61-119-IPB-11-3

FIGURE 7-11. FIBER OPTIC MODULE ASSEMBLY (SHEET 3 OF 3)



| FIG. &<br>INDEX<br>NUMBER | PART NUMBER        | FSCM  | DESCRIPTION  |   |   |   |   |   |   | UNITS<br>PER<br>ASSY | USABLE<br>ON<br>CODE | SMR<br>CODE |
|---------------------------|--------------------|-------|--|---|---|---|---|---|---|----------------------|----------------------|-------------|
|                           |                    |       | 1  | 2 | 3 | 4 | 5 | 6 | 7 |                      |                      |             |
| 7-11-                     | 812099-801         | 37695 | FIBER OPTIC MODULE ASSEMBLY (SEE . . . . .<br>FIGURE 7-2 OR FIGURE 7-22 FOR NHA) |   |   |   |   |   |   | REF                  |                      | PAFLD       |
| -1                        | FOMC7-2W1P-001     | 92708 | CONNECTOR, FIBER OPTIC (MAGNAVOX . . . . .<br>SPEC CONT DWG 626498-206)          |   |   |   |   |   |   | 1                    |                      | PADZZ       |
| -2                        | 136652-1           | 37695 | SCREW, CAP, SOCKET HD (AP) . . . . .   |   |   |   |   |   |   | 4                    |                      | PADZZ       |
| -3                        | 813732-801         | 37695 | CIRCUIT CARD ASSEMBLY (ESDS) . . . . .   |   |   |   |   |   |   | 1                    |                      | PADLD       |
| -4                        | MS51957-2          | 96906 | SCREW (AP) . . . . .   |   |   |   |   |   |   | 4                    |                      | PADZZ       |
|                           | MS35338-134        | 80205 | WASHER (AP) . . . . .  |   |   |   |   |   |   | 4                    |                      | PADZZ       |
| -5                        | M39014/02-1419     | 81349 | CAPACITOR . . . . .  |   |   |   |   |   |   | 2                    |                      | PADZZ       |
|                           | * M39014/02-1403   | 81349 | CAPACITOR . . . . .  |   |   |   |   |   |   | 2                    |                      | PADZZ       |
| -6                        | JANTX1N5618        | 81349 | SEMICONDUCTOR DEVICE . . . . .   |   |   |   |   |   |   | 2                    |                      | PADZZ       |
| -7                        | 107240-40          | 37695 | WASHER, NONMETALLIC . . . . .  |   |   |   |   |   |   | 2                    |                      | PADZZ       |
| -8                        | 5188-244-2         | 00779 | CONNECTOR, PLUG (MAGNAVOX SPEC . . . . .<br>CONT DWG 816370-1)                   |   |   |   |   |   |   | 1                    |                      | PADZZ       |
| -9                        | RCR20G300JS        | 81349 | RESISTOR . . . . .   |   |   |   |   |   |   | 1                    |                      | PADZZ       |
| -10                       | RCR05G101JS        | 81349 | RESISTOR . . . . .   |   |   |   |   |   |   | 1                    |                      | PADZZ       |
| -11                       | RCR07G104JS        | 81349 | RESISTOR . . . . .   |   |   |   |   |   |   | 1                    |                      | PADZZ       |
| -12                       | JANTX1N5968        | 81349 | SEMICONDUCTOR DEVICE . . . . .   |   |   |   |   |   |   | 1                    |                      | PADZZ       |
| -13                       | 617713-902         | 37695 | TRANSISTOR . . . . .   |   |   |   |   |   |   | 1                    |                      | PADZZ       |
| -14                       | 7717-15N           | 13103 | INSULATOR, TRANSISTOR . . . . .<br>(MAGNAVOX SPEC CONT DWG 447173-1)             |   |   |   |   |   |   | 1                    |                      | PADZZ       |
| -15                       | RCR20G330JS        | 81349 | RESISTOR . . . . .   |   |   |   |   |   |   | 1                    |                      | PADZZ       |
| -16                       | JANTX1N4454-1      | 81349 | SEMICONDUCTOR DEVICE . . . . .   |   |   |   |   |   |   | 2                    |                      | PADZZ       |
| -17                       | JANTX2N2222A       | 81349 | SEMICONDUCTOR DEVICE . . . . .   |   |   |   |   |   |   | 1                    |                      | PADZZ       |
| -18                       | M38527/3-02N       | 81349 | MOUNTING PAD, INSULATOR . . . . .  |   |   |   |   |   |   | 1                    |                      | XB          |
| -19                       | RCR07G301JS        | 81349 | RESISTOR . . . . .   |   |   |   |   |   |   | 1                    |                      | PADZZ       |
| -20                       | JANTX1N751A1       | 81349 | SEMICONDUCTOR DEVICE . . . . .   |   |   |   |   |   |   | 1                    |                      | PADZZ       |
| -21                       | RCR07G102JS        | 81349 | RESISTOR . . . . .   |   |   |   |   |   |   | 1                    |                      | PADZZ       |
| -22                       | 186767-1           | 37695 | CONNECTOR, PLUG . . . . .  |   |   |   |   |   |   | 1                    |                      | PADZZ       |
| -23                       | 813821-801         | 37695 | CABLE ASSEMBLY, FILTER OPTIC . . . . .   |   |   |   |   |   |   | 1                    |                      | PADZZ       |
| -24                       | M24066/2-308       | 81349 | CLIP, SOLID SPRING . . . . .   |   |   |   |   |   |   | 1                    |                      | XB          |
| -25                       | MS16535-64         | 96906 | RIVET (AP) . . . . .   |   |   |   |   |   |   | 1                    |                      | XB          |
| -26                       | RWR81S16R2FR       | 81349 | RESISTOR . . . . .   |   |   |   |   |   |   | 1                    |                      | PADZZ       |
| -27                       | 412647-1           | 37695 | PRINTED WIRING BOARD . . . . .   |   |   |   |   |   |   | 1                    |                      | XB          |
| -28                       | 938556-1           | 37695 | COVER, FIBER OPTIC . . . . .   |   |   |   |   |   |   | 1                    |                      | XB          |
| -29                       | MS51957-2          | 96906 | SCREW (AP) . . . . .   |   |   |   |   |   |   | 4                    |                      | PADZZ       |
|                           | MS35338-134        | 96906 | WASHER (AP) . . . . .  |   |   |   |   |   |   | 4                    |                      | PADZZ       |
| -30                       | 813733-801         | 37695 | CIRCUIT CARD ASSEMBLY (ESDS) . . . . .   |   |   |   |   |   |   | 1                    |                      | PADLD       |
| -31                       | MS51957-2          | 96906 | SCREW (AP) . . . . .   |   |   |   |   |   |   | 4                    |                      | PAFZZ       |
|                           | MS35338-134        | 96906 | WASHER (AP) . . . . .  |   |   |   |   |   |   | 4                    |                      | PADZZ       |
| -32                       | 940254-2           | 37695 | SHIELD, F/O RECEIVER . . . . .   |   |   |   |   |   |   | 1                    |                      | XB          |
| -33                       | 940254-801         | 37695 | SHIELD . . . . .   |   |   |   |   |   |   | 1                    |                      | XB          |
| -34                       | 5220-11-9          | 00779 | CONNECTOR, RECEPTACLE . . . . .<br>(MAGNAVOX SPEC CONT DWG 185928-109)           |   |   |   |   |   |   | 1                    |                      | PADZZ       |
| -35                       | 209452-1           | 37695 | TERMINAL, STUD . . . . .   |   |   |   |   |   |   | 1                    |                      | PADZZ       |
| -36                       | RCR05G222JS        | 81349 | RESISTOR . . . . .   |   |   |   |   |   |   | 2                    |                      | PADZZ       |
| -37                       | 275056-3242        | 37695 | CAPACITOR . . . . .  |   |   |   |   |   |   | 4                    |                      | PADZZ       |
| -38                       | RCR05G1003GR       | 81349 | RESISTOR . . . . .   |   |   |   |   |   |   | 2                    |                      | PADZZ       |
| -39                       | MS75085-19         | 96906 | COIL . . . . .   |   |   |   |   |   |   | 1                    |                      | PADZZ       |
| -40                       | M39014/01-1593     | 81349 | CAPACITOR . . . . .  |   |   |   |   |   |   | 3                    |                      | PADZZ       |
|                           | * M39014/01-1433   | 81349 | CAPACITOR . . . . .  |   |   |   |   |   |   | 3                    |                      | PADZZ       |
| -41                       | JM38510/11402BGX   | 81349 | MICROCIRCUIT (ESDS) . . . . .  |   |   |   |   |   |   | 2                    |                      | PADZZ       |
| -42                       | JANTX1N4458-1      | 81349 | SEMICONDUCTOR DEVICE . . . . .   |   |   |   |   |   |   | 2                    |                      | PADZZ       |
| -43                       | RLR05C3302GR       | 81349 | RESISTOR . . . . .   |   |   |   |   |   |   | 1                    |                      | PADZZ       |
| -44                       | RLR05C1001GR       | 81349 | RESISTOR . . . . .   |   |   |   |   |   |   | 1                    |                      | PADZZ       |
| -45                       | M39014/02-1419     | 81349 | CAPACITOR . . . . .  |   |   |   |   |   |   | 1                    |                      | PADZZ       |
|                           | * M39014/02-1403   | 81349 | CAPACITOR . . . . .  |   |   |   |   |   |   | 1                    |                      | PADZZ       |
| -46                       | RCR05G105JS        | 81349 | RESISTOR . . . . .   |   |   |   |   |   |   | 1                    |                      | PADZZ       |
| -47                       | RCR05G103JS        | 81349 | RESISTOR . . . . .   |   |   |   |   |   |   | 1                    |                      | PADZZ       |
| -48                       | RCR05G303JS        | 81349 | RESISTOR . . . . .   |   |   |   |   |   |   | 1                    |                      | PADZZ       |
| -49                       | JANTX1N5711        | 81349 | SEMICONDUCTOR DEVICE . . . . .   |   |   |   |   |   |   | 1                    |                      | PADZZ       |
| -50                       | 813820-801         | 37695 | PHOTO DIODE ASSEMBLY . . . . .   |   |   |   |   |   |   | 1                    |                      | PADZZ       |
| -51                       | M24066/2-304       | 81349 | CLIP, SOLID, SPRING . . . . .  |   |   |   |   |   |   | 1                    |                      | XB          |
| -52                       | MS16535-12         | 96906 | RIVET (AP) . . . . .   |   |   |   |   |   |   | 1                    |                      | XB          |
| -53                       | RCR05G514JS        | 81349 | RESISTOR . . . . .   |   |   |   |   |   |   | 1                    |                      | PADZZ       |
| -54                       | 619454-901         | 37695 | MICROCIRCUIT . . . . .   |   |   |   |   |   |   | 1                    |                      | PADZZ       |
|                           | = JM38510/10304BGX | 81349 | MICROCIRCUIT . . . . .   |   |   |   |   |   |   | 1                    |                      | PADZZ       |

T.O. 31R2-2GRC206-12

| FIGURE<br>& INDEX<br>NUMBER | PART<br>NUMBER | FSCM  | DESCRIPTION |   |                            |   |   |   |   | UNITS<br>PER<br>ASSY | USABLE<br>ON<br>CODE | SMR<br>CODE |
|-----------------------------|----------------|-------|-------------|---|----------------------------|---|---|---|---|----------------------|----------------------|-------------|
|                             |                |       | 1           | 2 | 3                          | 4 | 5 | 6 | 7 |                      |                      |             |
| 7-11-55                     | 412648-1       | 37695 | .           | . | PRINTED WIRING BOARD ..... |   |   |   |   | 1                    |                      | XB          |
| -56                         | 5153268-1      | 37695 | .           |   | BRACKET, SIDE PLATE .....  |   |   |   |   | 2                    |                      | XB          |
| -57                         | 195-9505-000   | 71468 | .           |   | CONTACT, FIBER OPTIC ..... |   |   |   |   | 1                    |                      | PADZZ       |
| -58                         | 024-9512-004   | 71468 | .           |   | COVER, FIBER OPTIC.....    |   |   |   |   | 1                    |                      | PADZZ       |

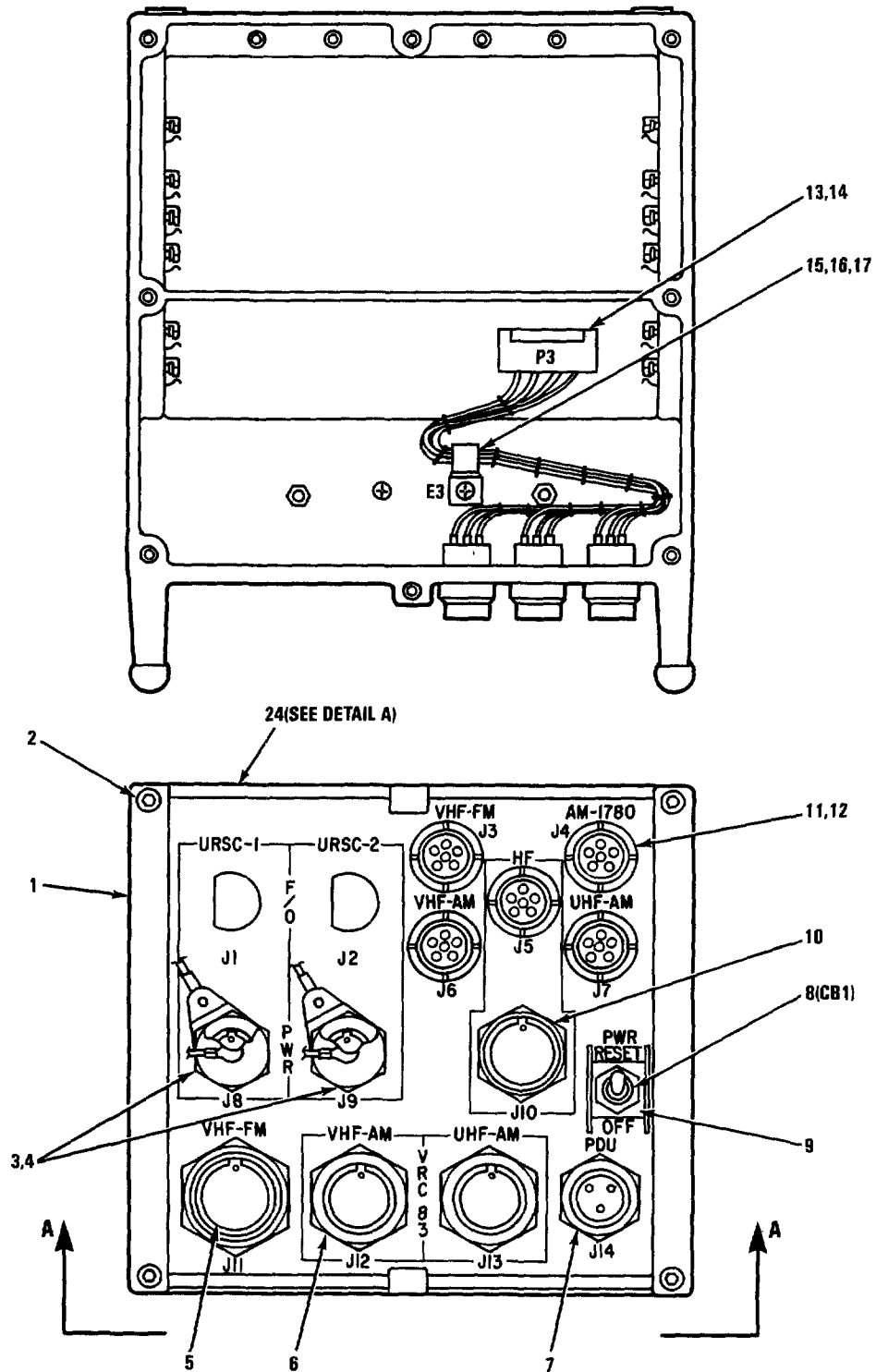

NOTE: REFERENCE DESIGNATIONS ARE ABBREVIATED.  
PREFIX WITH 1.

MX-61-119-IPB-12-1  
REF MAG DWG 812086 REV H  
PL 812086 REV AK

FIGURE 7-12. ELECTRICAL EQUIPMENT CHASSIS (SHEET 1 OF 2)

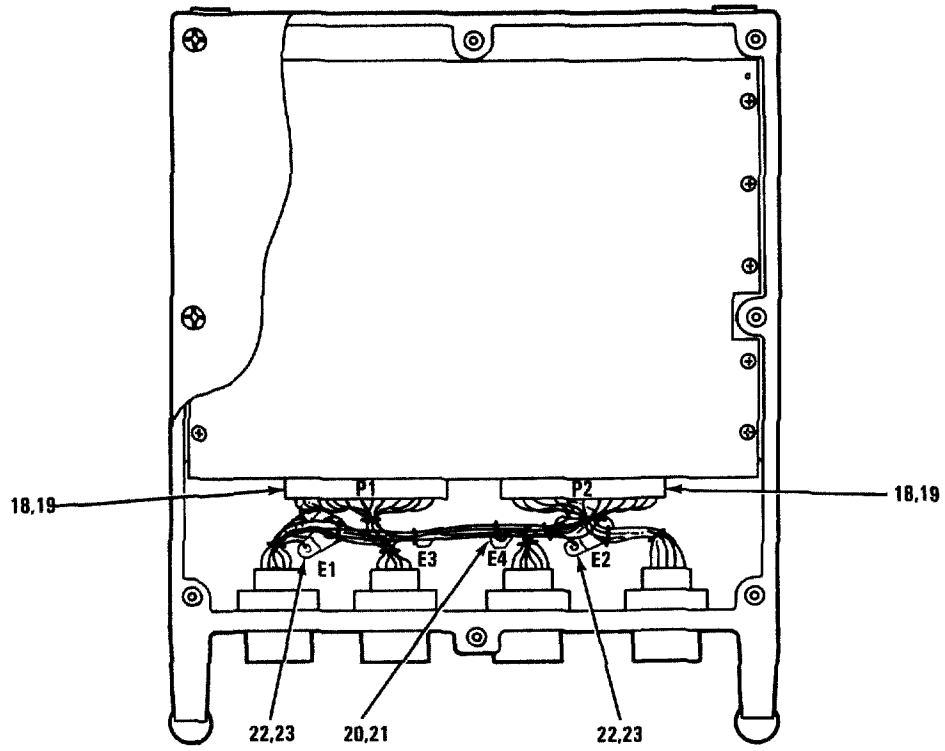

VIEW A-A

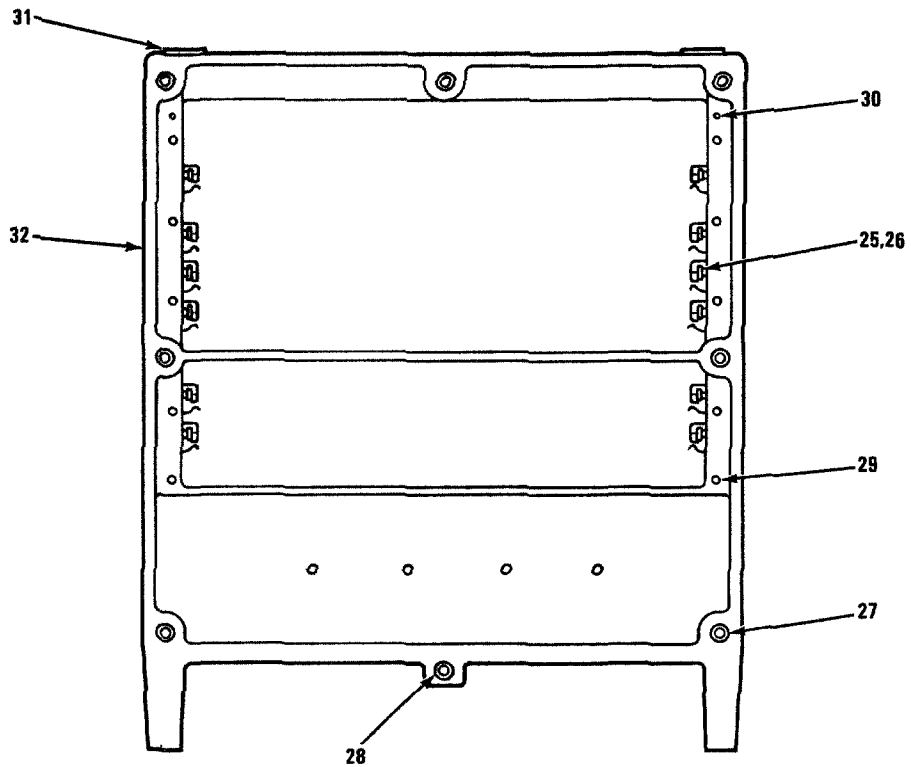

DETAIL A

NOTE: REFERENCE DESIGNATIONS ARE ABBREVIATED.  
PREFIX WITH 1.

MX-61-119-IPB-12-2

FIGURE 7-12. ELECTRICAL EQUIPMENT CHASSIS (SHEET 2 OF 2)

| FIG. &<br>INDEX<br>NO. | PART NUMBER                    | FSCM<br>1234567 | DESCRIPTION  | UNITS<br>PER<br>ASSY. | USABLE<br>ON<br>CODE | SMR<br>CODE |
|------------------------|--------------------------------|-----------------|--|-----------------------|----------------------|-------------|
| 7-12-                  | B12086-801                     | 37695           | CHASSIS, ELECTRICAL EQUIPMENT . . . . .<br>(SEE FIGURE 7-2 FOR NHA)      | REF                   |                      | PAFDD       |
| -1                     | 514891-1                       | 37695           | HANDLE, DISTRIBUTION UNIT. . . . .                                       | 2                     |                      | XB          |
| -2                     | MS16995-26B                    | 96906           | SCREW (AP). . . . .  | 4                     |                      | PAFZZ       |
| -3                     | MS3181-10R                     | 81349           | COVER (MAGNAVOX SPEC. . . . .<br>CONT DWG 186749-1)                      | 2                     |                      | PAFZZ       |
| -4                     | MS3114E10-6S                   | 96906           | CONNECTOR . . . . .  | 2                     |                      | PADZZ       |
| -5                     | MS3114E18-32S                  | 96906           | CONNECTOR . . . . .  | 1                     |                      | PADZZ       |
| -6                     | MS3114E16-26S                  | 96906           | CONNECTOR . . . . .  | 2                     |                      | PADZZ       |
| -7                     | MS3474W12-3P                   | 96906           | CONNECTOR . . . . .  | 1                     |                      | PADZZ       |
| -8                     | M39019/01-230                  | 81349           | CIRCUIT BREAKER . . . . .  | 1                     |                      | PADZZ       |
| -9                     | 939205-2                       | 37695           | GUARD, SWITCH. . . . .   | 1                     |                      | XB          |
| -10                    | PVJ7814819MSNN                 | 08717           | CONNECTOR, RFI FILTERED. . . . .<br>(MAGNAVOX SPEC CONT<br>DWG 186807-1) | 1                     |                      | PADZZ       |
| -11                    | 9C-283                         | 25330           | CONNECTOR, RECEPTACLE (MAGNAVOX. . . . .<br>SPEC CONT DWG 186137-1)      | 5                     |                      | PADZZ       |
| -12                    | D-144-34                       | 06090           | SPLICE, CONDUCTOR (MAGNAVOX. . . . .<br>SPEC CONT DWG 349645-1)          | 5                     |                      | PADZZ       |
| -13                    | 2-87631-2                      | 00779           | CONNECTOR, BODY, PLUG (MAGNAVOX . . . . .<br>SPEC CONT DWG 185971-6)     | 1                     |                      | PADZZ       |
| -14                    | B7046-3                        | 00779           | CONTACT, ELECTRICAL (MAGNAVOX. . . . .<br>SPEC CONT DWG 165338-5) (AP)   | 26                    |                      | PADZZ       |
| -15                    | NAS1397R5B                     | 80205           | CLAMP . . . . .  | 1                     |                      | PAFZZ       |
| -16                    | MS51957-15                     | 96906           | SCREW (AP). . . . .  | 1                     |                      | PAFZZ       |
|                        | D4-128CAD PLATE<br>IRID YELLOW | 93987           | WASHER, SADDLE (MAGNAVOX . . . . .<br>SPEC CONT DWG 109605-1)<br>(AP)    | 1                     |                      | PAFZZ       |
|                        | MS35338-135                    | 96906           | WASHER (AP) . . . . .  | 1                     |                      | PAFZZ       |
| -17                    | SE20XD01                       | 81349           | TERMINAL. . . . .  | 1                     |                      | PADZZ       |
| -18                    | M55302/B-04                    | 81349           | CONNECTOR . . . . .  | 2                     |                      | PADZZ       |
| -19                    | D-136-05                       | 06090           | SPLICE, CONDUCTOR (MAGNAVOX. . . . .<br>SPEC CONT DWG 446949-7)          | 77                    |                      | PADZZ       |
| -20                    | SE20XD01                       | 81349           | TERMINAL. . . . .  | 1                     |                      | PADZZ       |
| -21                    | MS51957-13                     | 96906           | SCREW (AP). . . . .  | 1                     |                      | PAFZZ       |
|                        | MS35338-135                    | 96906           | WASHER (AP) . . . . .  | 1                     |                      | PAFZZ       |
|                        | NAS620C5L                      | 80205           | WASHER (AP) . . . . .  | 1                     |                      | PAFZZ       |
| -22                    | MS77068-2                      | 96906           | TERMINAL. . . . .  | 6                     |                      | XB          |
| -23                    | MS51957-27                     | 96906           | SCREW (AP). . . . .  | 2                     |                      | XB          |
|                        | MS35338-136                    | 96906           | WASHER (AP) . . . . .  | 2                     |                      | PAFZZ       |
|                        | NAS671C6                       | 80205           | NUT (AP). . . . .  | 2                     |                      | PAFZZ       |
| -24                    | 660150-801                     | 37695           | CASE, SIGNAL DISTRIBUTION. . . . .                                       | 1                     |                      | ADD         |
| -25                    | 435656-1                       | 37695           | GUIDE, PRINTED CIRCUIT. . . . .  | 12                    |                      | XB          |
| -26                    | 136556-1                       | 37695           | RIVET, SHOULDER (AP). . . . .  | 2                     |                      | XB          |
| -27                    | MS122118                       | 96906           | INSERT . . . . .   | 18                    |                      | PAFZZ       |
| -28                    | MS122078                       | 96906           | INSERT . . . . .   | 2                     |                      | XB          |
| -29                    | MS122116                       | 96906           | INSERT . . . . .   | 10                    |                      | PAFZZ       |
| -30                    | MS16562-190                    | 96906           | PIN. . . . .   | 2                     |                      | PAFZZ       |
| -31                    | 514892-1                       | 37695           | BUSHING, GUIDE PIN. . . . .  | 2                     |                      | XB          |
| -32                    | 660150-1                       | 37695           | CASE, SIGNAL DISTRIBUTION UNIT. . . . .                                  | 1                     |                      | XB          |

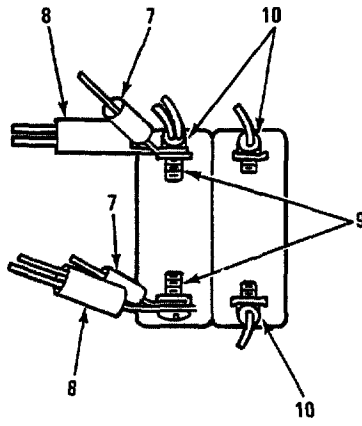

VIEW A-A

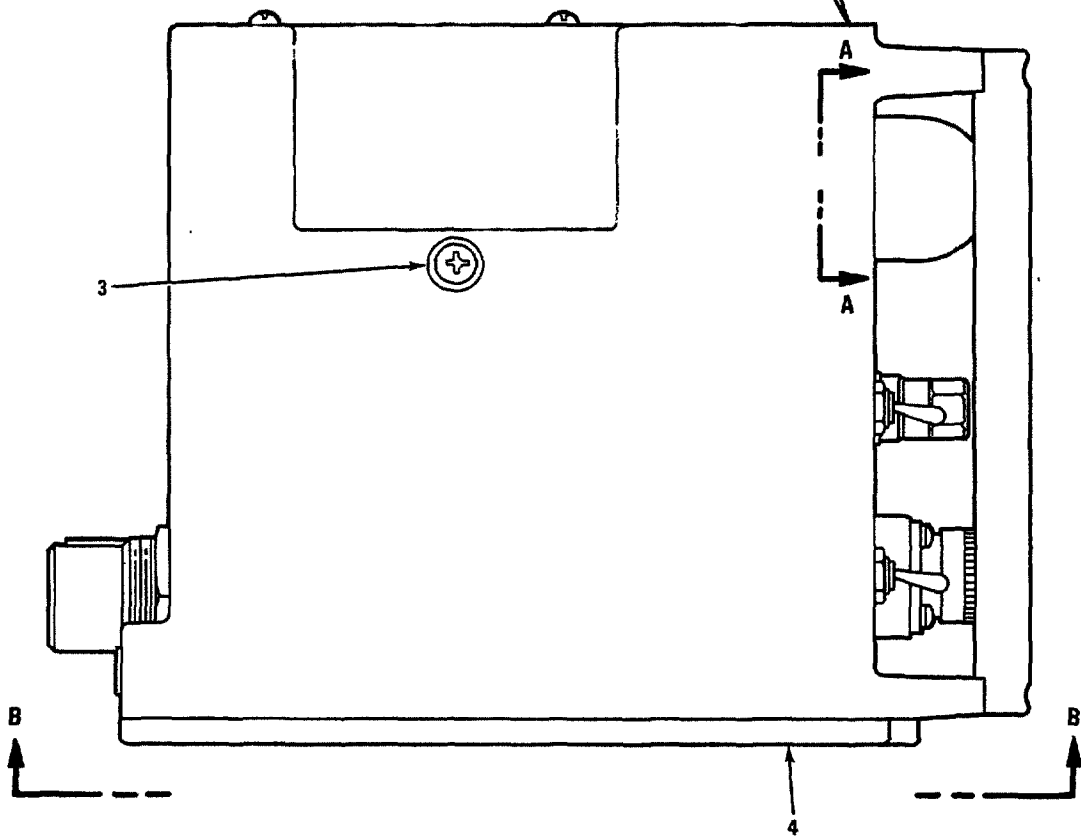
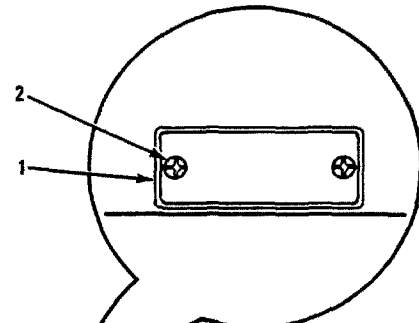

SIDE VIEW

NOTE: REFERENCE DESIGNATIONS ARE ABBREVIATED.  
PREFIX WITH 2.

MX-61-119-IPB-13-1  
REF MAG DWG 812082 REV D  
PL 812082 REV R

FIGURE 7-13. POWER SWITCHBOARD, SB-4151/0RC-206 (SHEET 1 OF 2)

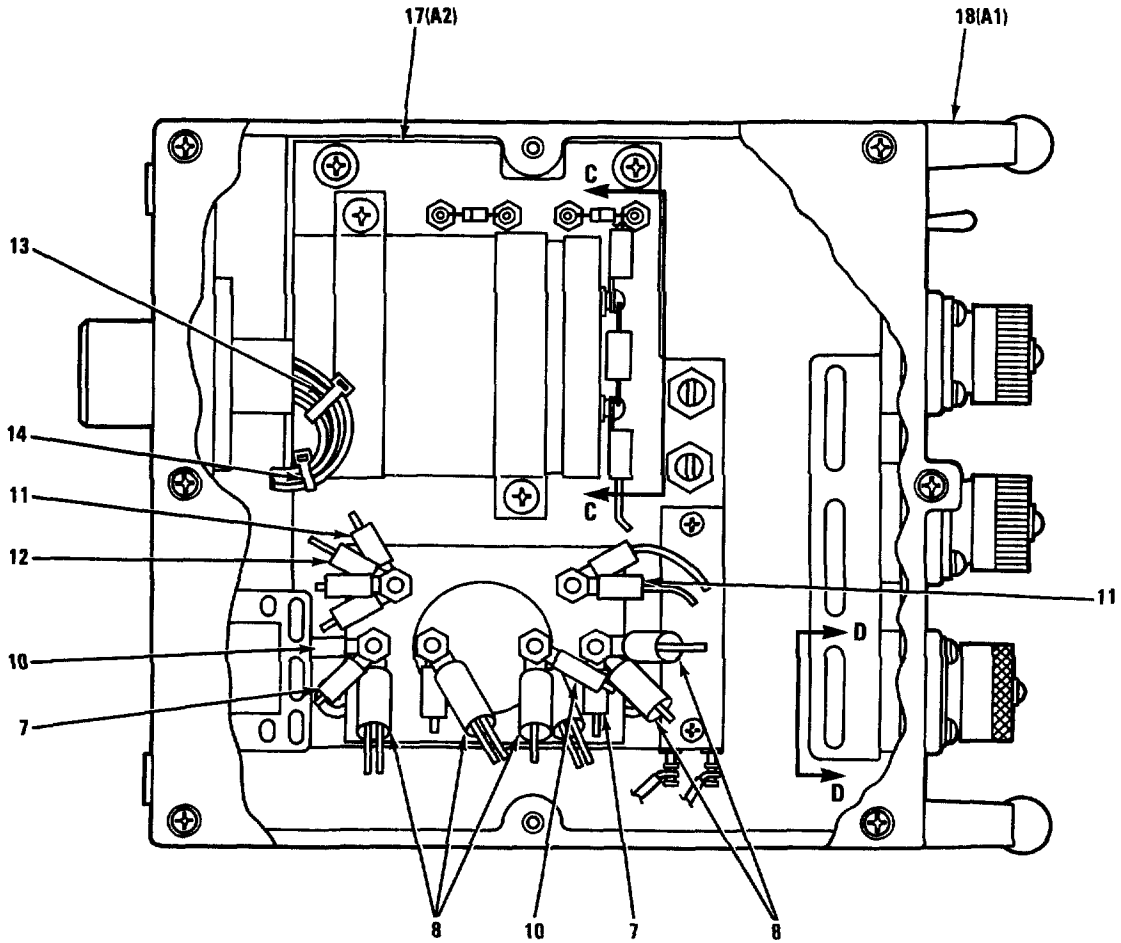

VIEW B-B

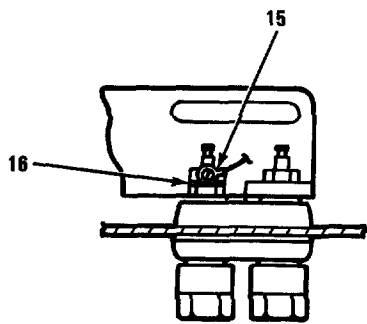

VIEW C-C

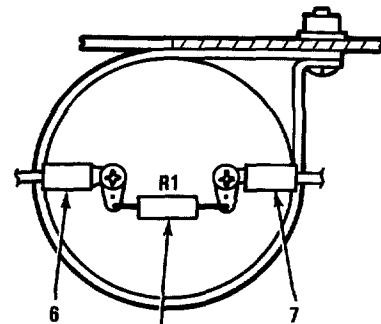

VIEW D-D

NOTE: REFERENCE DESIGNATIONS ARE ABBREVIATED.  
PREFIX WITH 2.

MX-61-119-IPB-13-2

FIGURE 7-13. POWER SWITCHBOARD, SB-4151/0RC-206 (SHEET 2 OF 2)

TO 31R2-2GRC206-12

| FIG. &<br>INDEX<br>NUMBER | PART NUMBER | FSCM  | DESCRIPTION  |   |   |   |   |   |   | UNITS<br>PER<br>ASSY | USABLE<br>ON<br>CODE | SMR<br>CODE |
|---------------------------|-------------|-------|--|---|---|---|---|---|---|----------------------|----------------------|-------------|
|                           |             |       | 1  | 2 | 3 | 4 | 5 | 6 | 7 |                      |                      |             |
| 7-13-                     | 812082-801  | 37695 | POWER SWITCHBOARD, SB-4151/GRC-206 . . . . .<br>(SEE FIGURE 7-1 FOR NHA) |   |   |   |   |   |   | REF                  |                      | PAODD       |
| -1                        | 155896-*    | 37695 | . PLATE, IDENTIFICATION . . . . .  |   |   |   |   |   |   | 1                    |                      | MDD         |
| -2                        | MS51957-11  | 96906 | . SCREW (AP) . . . . .   |   |   |   |   |   |   | 2                    |                      | PAFZZ       |
| -3                        | MS3213-31   | 96906 | . SCREW . . . . .  |   |   |   |   |   |   | 1                    |                      | PAFZZ       |
| -4                        | 660152-802  | 37695 | . COVER, DISTRIBUTION UNIT (SEE . . . . .<br>FIGURE 7-3 FOR BKDN)        |   |   |   |   |   |   | 1                    |                      | XB          |
| -5                        | RGR32G222JS | 81349 | . RESISTOR. . . . .  |   |   |   |   |   |   | 1                    |                      | PADZZ       |
| -6                        | MS77068-4   | 96906 | . TERMINAL. . . . .  |   |   |   |   |   |   | 2                    |                      | PADZZ       |
| -7                        | MS25036-108 | 96906 | . TERMINAL. . . . .  |   |   |   |   |   |   | 7                    |                      | PADZZ       |
| -8                        | 324043      | 00779 | . TERMINAL, LUG (MAGNAVOX SPEC CONT. . . . .<br>DWG 205003-13)           |   |   |   |   |   |   | 7                    |                      | PADZZ       |
| -9                        | MS51958-61  | 96906 | . SCREW (AP) . . . . .   |   |   |   |   |   |   | 4                    |                      | PAFZZ       |
| -10                       | MS25036-103 | 96906 | . TERMINAL. . . . .  |   |   |   |   |   |   | 5                    |                      | PADZZ       |
| -11                       | MS25036-102 | 96906 | . TERMINAL. . . . .  |   |   |   |   |   |   | 3                    |                      | PADZZ       |
| -12                       | MS25036-107 | 96906 | . TERMINAL. . . . .  |   |   |   |   |   |   | 3                    |                      | PADZZ       |
| -13                       | MS3367-4-9  | 96906 | . STRAP. . . . .   |   |   |   |   |   |   | 25                   |                      | PADZZ       |
| -14                       | MS3367-1-0  | 96906 | . STRAP. . . . .   |   |   |   |   |   |   | 15                   |                      | PAFZZ       |
| -15                       | MS25036-153 | 96906 | . TERMINAL. . . . .  |   |   |   |   |   |   | 3                    |                      | PADZZ       |
| -16                       | MS35333-72  | 96906 | . WASHER . . . . .   |   |   |   |   |   |   | 3                    |                      | PAFZZ       |
| -17                       | 812991-801  | 37695 | . MOUNTING PLATE ASSEMBLY (SEE . . . . .<br>FIGURE 7-14 FOR BKDN)        |   |   |   |   |   |   | 1                    |                      | XB          |
| -18                       | 812088-801  | 37695 | . CHASSIS ELECTRICAL EQUIPMENT (SEE . . . . .<br>FIGURE 7-15 FOR BKDN)   |   |   |   |   |   |   | 1                    |                      | PAFDD       |



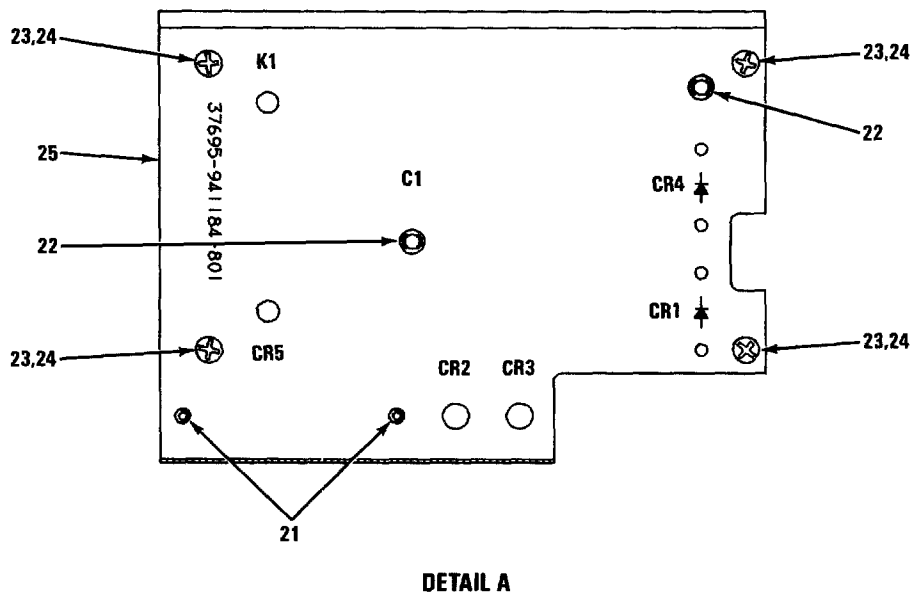
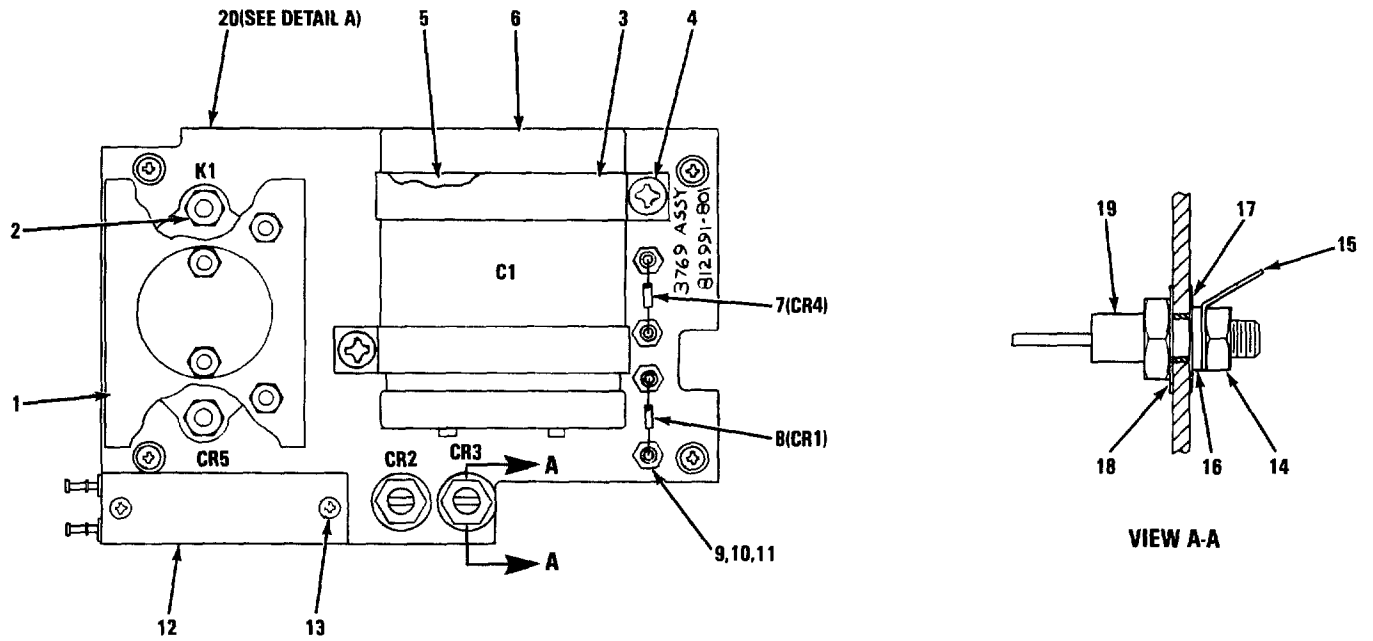

NOTE: REFERENCE DESIGNATIONS ARE ABBREVIATED.  
PREFIX WITH 2A2.

MX-61-119-IPB-14  
REF MAG DWG 812991 REV D  
PL 812991 REV J

FIGURE 7-14. MOUNTING PLATE ASSEMBLY

| FIG. & INDEX NO. | PART NUMBER     | FSCM  | 1234567 | DESCRIPTION  | UNITS PER ASSY. | USABLE ON CODE | SMR CODE |
|------------------|-----------------|-------|---------|--|-----------------|----------------|----------|
| 7-14-            | 812991-801      | 37695 |         | MOUNTING PLATE ASSEMBLY (SEE . . . . REF FIGURE 7-13 FOR NHA)            |                 |                | XB       |
| -1               | MS24187D2       | 96906 |         | RELAY . . . . .  | 1               |                | PAFZZ    |
| -2               | MS51958-62      | 96906 |         | SCREW (AP). . . . .  | 2               |                | PAFZZ    |
|                  | MS21044C3       | 96906 |         | NUT (AP). . . . .  | 2               |                | PAFZZ    |
| -3               | MS21333-89      | 96906 |         | CLAMP, LOOP. . . . .   | 2               |                | PADZZ    |
| -4               | MS51958-61      | 96906 |         | SCREW (AP). . . . .  | 2               |                | PAFZZ    |
| -5               | 348297-13       | 37695 |         | PAD, RUBBER. . . . .   | 2               |                | XB       |
| -6               | 101X792U075CB2A | 00853 |         | CAPACITOR (MAGNAVOX SPEC CONT DWG 275109-1)                              | 1               |                | PADZZ    |
| -7               | JANTX1N5651A    | 81349 |         | SEMICONDUCTOR DEVICE. . . . .  | 1               |                | PADZZ    |
| -8               | JANTX1N447B     | 81349 |         | SEMICONDUCTOR DEVICE. . . . .  | 1               |                | PADZZ    |
| -9               | SE20XD01        | 81349 |         | TERMINAL, STUD . . . . .   | 4               |                | PADZZ    |
| -10              | MS51957-13      | 96906 |         | SCREW (AP). . . . .  | 4               |                | PAFZZ    |
| -11              | MS35338-135     | 96906 |         | WASHER (AP) . . . . .  | 4               |                | PAFZZ    |
| -12              | 616497-903      | 37695 |         | SEMICONDUCTOR DEVICE. . . . .  | 1               |                | PADZZ    |
| -13              | MS51957-21      | 96906 |         | SCREW (AP). . . . .  | 2               |                | PAFZZ    |
|                  | AN960C4         | 88044 |         | WASHER (AP) . . . . .  | 2               |                | PAFZZ    |
| -14              | NAS671C10       | 80205 |         | NUT . . . . .  | 2               |                | PAFZZ    |
| -15              | MS77068-4       | 96906 |         | TERMINAL, LUG. . . . .   | 2               |                | PADZZ    |
| -16              | NAS620C10       | 80205 |         | WASHER. . . . .  | 2               |                | PAFZZ    |
| -17              | 109429-3        | 37695 |         | MOUNTING, PAD INSULATOR. . . . .   | 2               |                | XB       |
| -18              | 446731-2        | 37695 |         | WASHER, SHOULDERED . . . . .   | 2               |                | PADZZ    |
| -19              | JAN1N1614       | 81349 |         | SEMICONDUCTOR DEVICE. . . . .  | 2               |                | PADZZ    |
| -20              | 941184-801      | 37695 |         | PLATE, MOUNTING. . . . .   | 1               |                | XB       |
| -21              | M45938/5-4C     | 81349 |         | NUT, PLAIN, CLINCH . . . . .   | 2               |                | PAFZZ    |
| -22              | M45938/5-8C     | 81349 |         | NUT, PLAIN, CLINCH . . . . .   | 2               |                | PAFZZ    |
| -23              | CA29040-06-3-5P | 29372 |         | SCREW ASSEMBLY, CAPTIVE-SPRING, LOADED (MAGNAVOX SPEC CONT DWG 109627-3) | 4               |                | PAFZZ    |
| -24              | MS35335-58      | 96906 |         | WASHER . . . . .   | 4               |                | PAFZZ    |
| -25              | 941184-1        | 37695 |         | PLATE, MOUNTING . . . . .  | 1               |                | XB       |

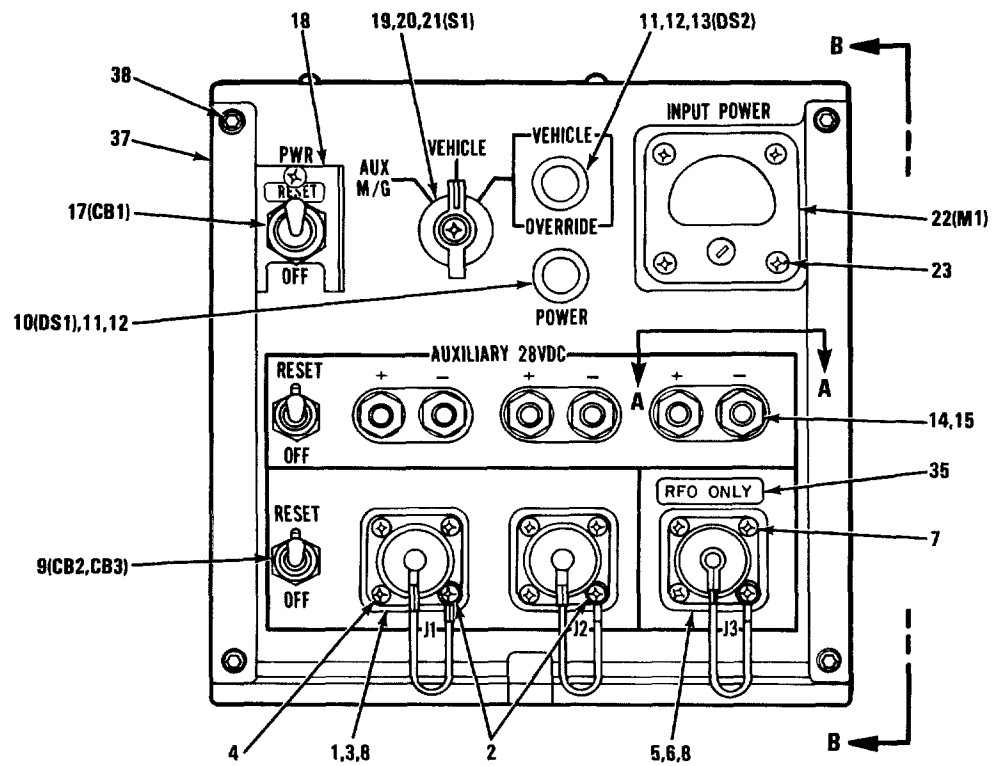
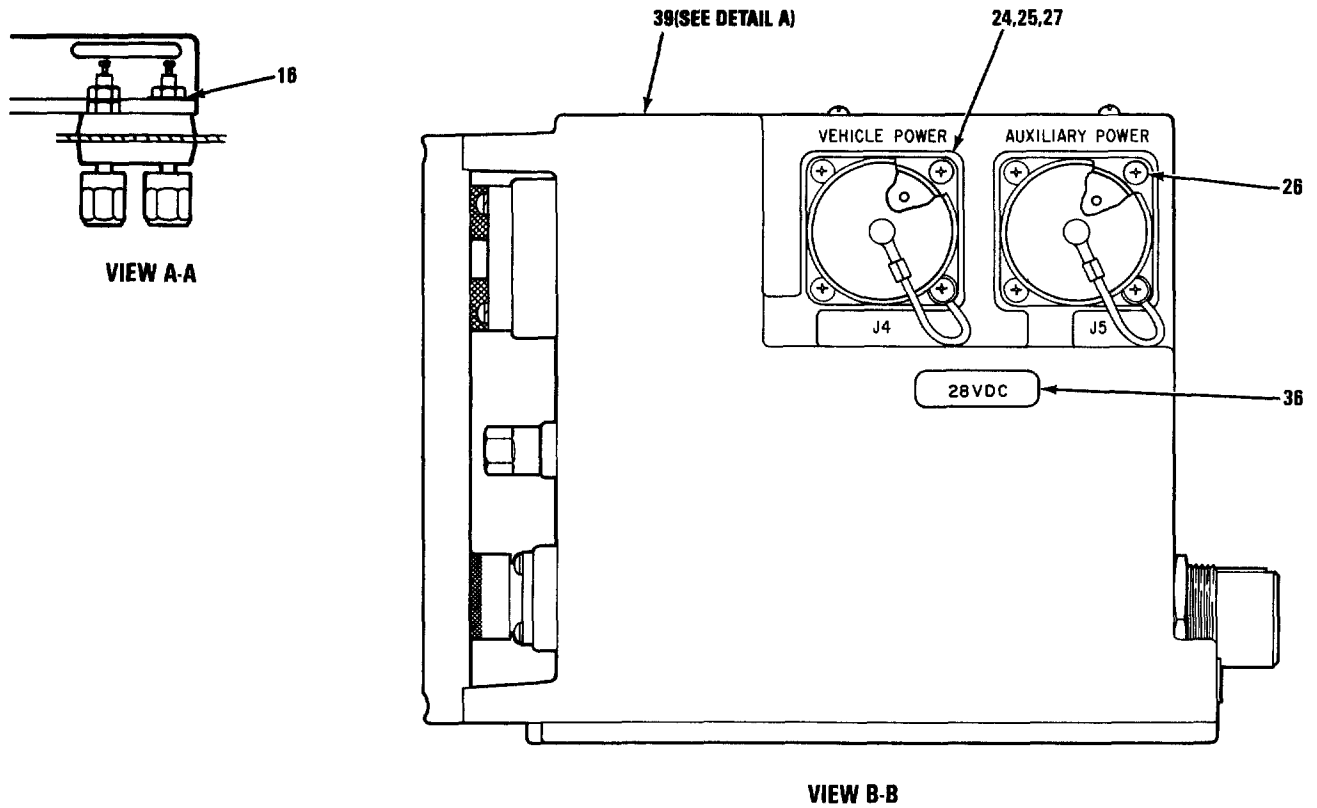

NOTE: REFERENCE DESIGNATIONS ARE ABBREVIATED.  
PREFIX WITH 2A1.

MX-61-119-IPB-15-1  
REF MAG DWG 812088 REV G  
PL 812088 REV AA

FIGURE 7-15. ELECTRICAL EQUIPMENT CHASSIS (SHEET 1 OF 3)

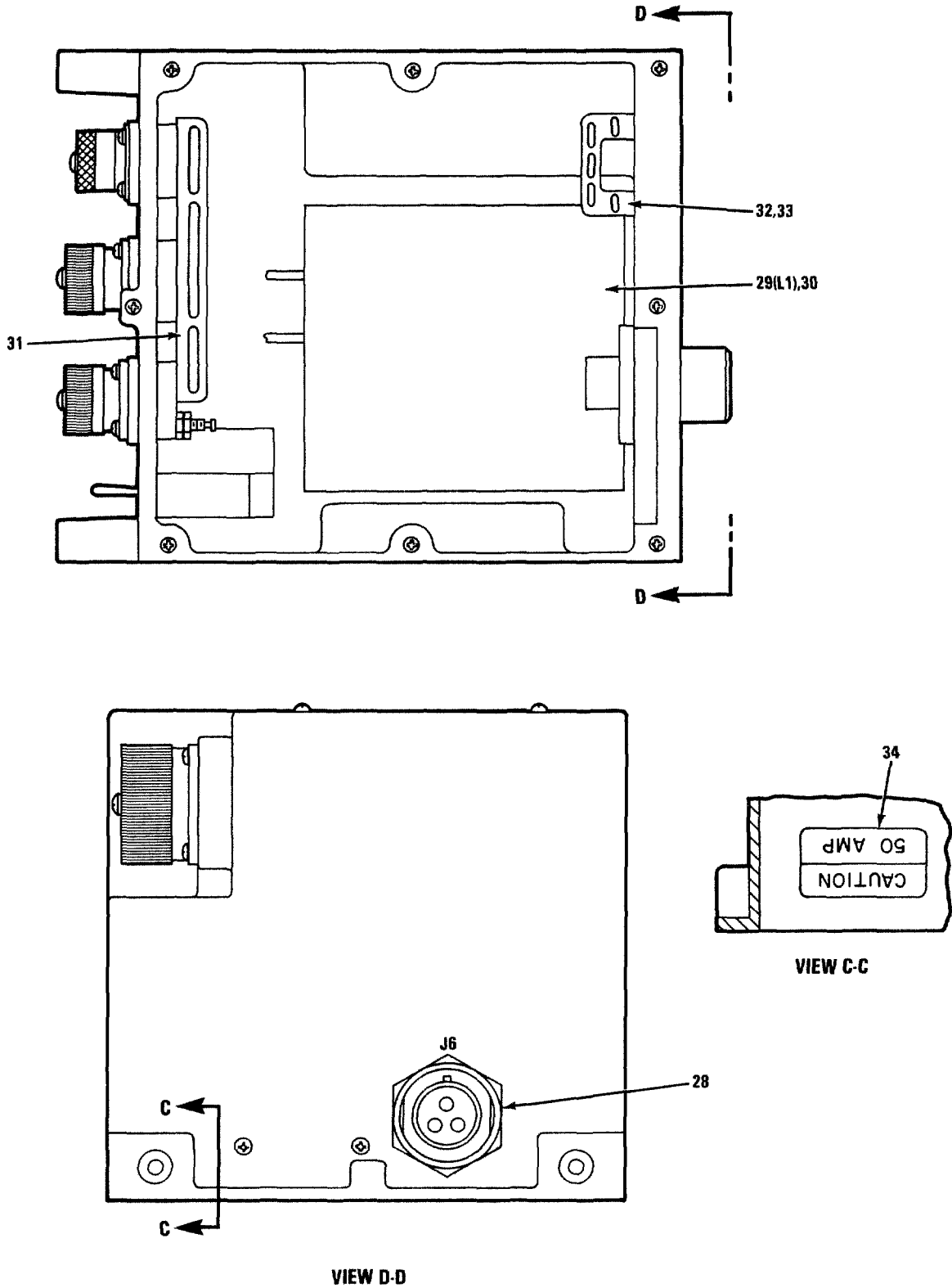

NOTE: REFERENCE DESIGNATIONS ARE ABBREVIATED.  
PREFIX WITH 2A1.

MX-61-119-IPB-15-2

FIGURE 7-15. ELECTRICAL EQUIPMENT CHASSIS (SHEET 2 OF 3)

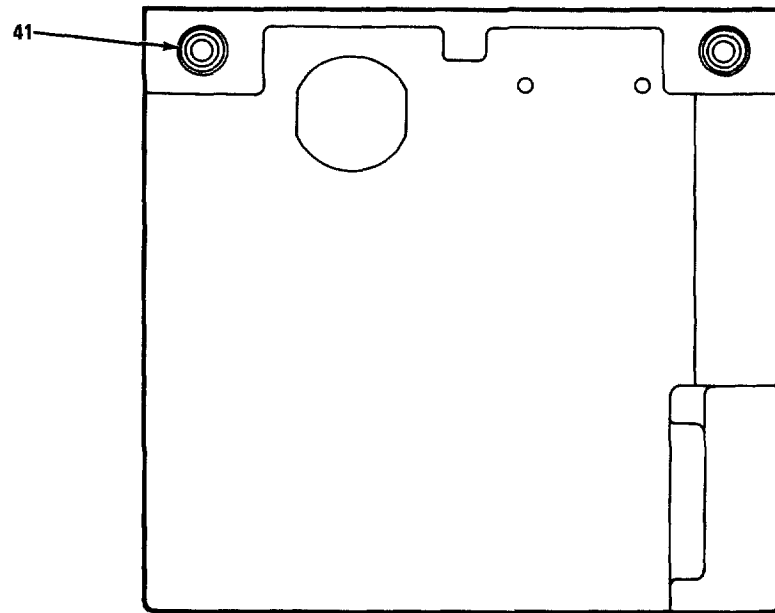
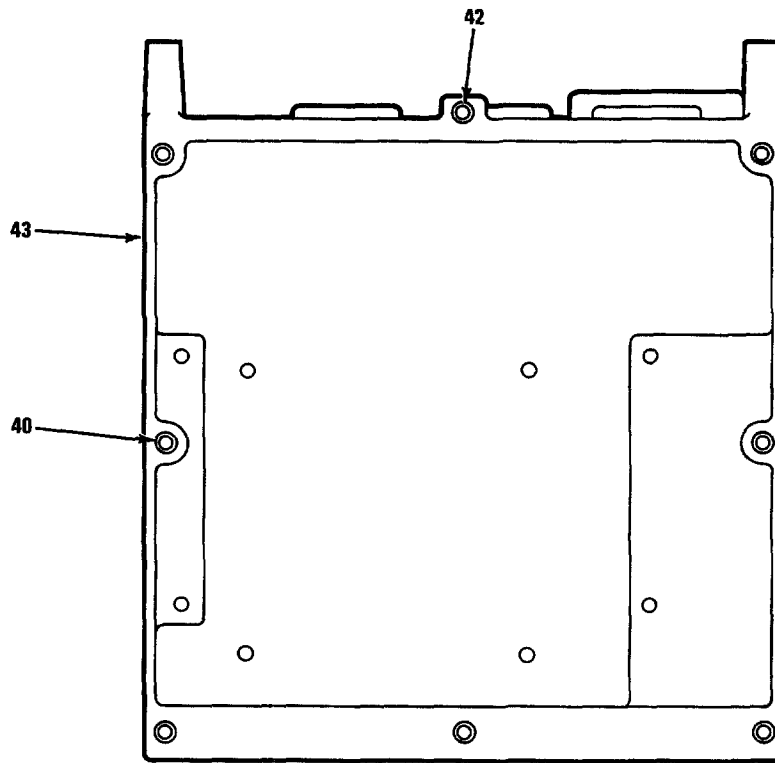

DETAIL A

NOTE: REFERENCE DESIGNATIONS ARE ABBREVIATED.  
PREFIX WITH 2A1.

MX-61-119-IPB-15-3

FIGURE 7-15. ELECTRICAL EQUIPMENT CHASSIS (SHEET 3 OF 3)

TO 31R2-2GRC206-12

| FIG. &<br>INDEX<br>NUMBER | PART NUMBER     | FSCM  | DESCRIPTION                                 |   |   |   |   |   |   | UNITS<br>PER<br>ASSY | USABLE<br>ON<br>CODE | SMR<br>CODE |
|---------------------------|-----------------|-------|---|---|---|---|---|---|---|----------------------|----------------------|-------------|
|                           |                 |       | 1   | 2 | 3 | 4 | 5 | 6 | 7 |                      |                      |             |
| 7-15-                     | 812088-801      | 37695 | ELECTRICAL EQUIPMENT, CHASSIS . . . . .     |   |   |   |   |   |   | REF                  |                      | PAFDD       |
|                           |                 |       | (SEE FIGURE 7-13 FOR NHA)                   |   |   |   |   |   |   |                      |                      |             |
| -1                        | CA121003-2      | 08718 | COVER,CONNECTOR (MAGNAVOX . . . . .         |   |   |   |   |   |   | 2                    |                      | XB          |
|                           |                 |       | SPEC CONT DWG 186357-2)                     |   |   |   |   |   |   |                      |                      |             |
| -2                        | AN960C4         | 88044 | SCREW (AP) . . . . .                        |   |   |   |   |   |   | 2                    |                      | XB          |
| -3                        | CA3102E12S-3SB  | 71468 | CONNECTOR, RECEPTACLE (MAGNAVOX . . . . .   |   |   |   |   |   |   | 2                    |                      | PADZZ       |
|                           |                 |       | SPEC CONT DWG 186358-1)                     |   |   |   |   |   |   |                      |                      |             |
| -4                        | MS51957-15B     | 96906 | SCREW (AP) . . . . .                        |   |   |   |   |   |   | 8                    |                      | PAFZZ       |
|                           | MS35338-135     | 96906 | WASHER (AP) . . . . .                       |   |   |   |   |   |   | 8                    |                      | PAFZZ       |
| -5                        | 660-009B12U4-00 | 06324 | COVER, CONNECTOR (MAGNAVOX SPEC . . . . .   |   |   |   |   |   |   | 1                    |                      | XB          |
|                           |                 |       | CONT DWG 186315-1)                          |   |   |   |   |   |   |                      |                      |             |
| -6                        | MS3112E12-3S    | 96906 | CONNECTOR, RECEPTACLE . . . . .             |   |   |   |   |   |   | 1                    |                      | PADZZ       |
| -7                        | MS51957-14B     | 96906 | SCREW (AP) . . . . .                        |   |   |   |   |   |   | 4                    |                      | PAFZZ       |
|                           | MS35338-135     | 96906 | WASHER (AP) . . . . .                       |   |   |   |   |   |   | 4                    |                      | PAFZZ       |
| -8                        | 82-61654        | 07700 | SHIELDING, GASKET (MAGNAVOX SPEC . . . . .  |   |   |   |   |   |   | 3                    |                      | XB          |
|                           |                 |       | CONT DWG 445994-3)                          |   |   |   |   |   |   |                      |                      |             |
| -9                        | M39019/01-248   | 81349 | CIRCUIT BREAKER . . . . .                   |   |   |   |   |   |   | 2                    |                      | PAFZZ       |
| -10                       | LC360D2         | 81349 | LAMPHOLDER, LENS . . . . .                  |   |   |   |   |   |   | 1                    |                      | PAFZZ       |
| -11                       | MS25237-387     | 96906 | LAMP, INCANDESCENT . . . . .                |   |   |   |   |   |   | 2                    |                      | PAOZZ       |
| -12                       | LH89/1          | 81349 | HOUSING, INDICATOR . . . . .                |   |   |   |   |   |   | 2                    |                      | PAFZZ       |
| -13                       | LC36YD2         | 81349 | LAMPHOLDER, LENS . . . . .                  |   |   |   |   |   |   | 1                    |                      | PAFZZ       |
| -14                       | BP30-2-BR       | 58474 | POST, BINDING (MAGNAVOX SPEC CONT . . . . . |   |   |   |   |   |   | 6                    |                      | PAFZZ       |
|                           |                 |       | DWG 186180-1)                               |   |   |   |   |   |   |                      |                      |             |
| -15                       | 348293-1        | 37695 | GASKET, BINDING POST . . . . .              |   |   |   |   |   |   | 3                    |                      | XB          |
| -16                       | MS35333-72      | 96906 | WASHER . . . . .                            |   |   |   |   |   |   | 3                    |                      | PAFZZ       |
| -17                       | UPGN66-8251-1   | 81541 | CIRCUIT BREAKER (MAGNAVOX SPEC . . . . .    |   |   |   |   |   |   | 1                    |                      | PAFZZ       |
|                           |                 |       | CONT DWG 165431-1)                          |   |   |   |   |   |   |                      |                      |             |
| -18                       | 939205-1        | 37695 | GUARD, SWITCH . . . . .                     |   |   |   |   |   |   | 1                    |                      | XB          |
| -19                       | MS91525-OAW3SBZ | 96906 | KNOB, CONTROL . . . . .                     |   |   |   |   |   |   | 1                    |                      | PAFZZ       |
| -20                       | MS51957-26B     | 96906 | SCREW (AP) . . . . .                        |   |   |   |   |   |   | 1                    |                      | PAFZZ       |
|                           | MS35338-136     | 96906 | WASHER (AP) . . . . .                       |   |   |   |   |   |   | 1                    |                      | PAFZZ       |
| -21                       | 5-15611-469     | 76854 | SWITCH, ROTARY (MAGNAVOX SPEC . . . . .     |   |   |   |   |   |   | 1                    |                      | PADZZ       |
|                           |                 |       | CONT DWG 165436-1)                          |   |   |   |   |   |   |                      |                      |             |
| -22                       | MR13W050DCVVR   | 81349 | METER, VOLT . . . . .                       |   |   |   |   |   |   | 1                    |                      | PAFZZ       |
| -23                       | MS51957-18B     | 96906 | SCREW (AP) . . . . .                        |   |   |   |   |   |   | 4                    |                      | PAFZZ       |
|                           | MS35338-135     | 96906 | WASHER (AP) . . . . .                       |   |   |   |   |   |   | 4                    |                      | PAFZZ       |
| -24                       | CA121003-9      | 08718 | COVER, CONNECTOR (MAGNAVOX SPEC . . . . .   |   |   |   |   |   |   | 1                    |                      | XB          |
|                           |                 |       | CONT DWG 186357-1)                          |   |   |   |   |   |   |                      |                      |             |
| -25                       | CA3102E24-22PB  | 71468 | CONNECTOR, BAYONET (MAGNAVOX . . . . .      |   |   |   |   |   |   | 2                    |                      | PAFZZ       |
|                           |                 |       | SPEC CONT DWG 186359-1)                     |   |   |   |   |   |   |                      |                      |             |
| -26                       | MS51957-29B     | 96906 | SCREW (AP) . . . . .                        |   |   |   |   |   |   | 8                    |                      | PAFZZ       |
|                           | MS35338-136     | 96906 | WASHER (AP) . . . . .                       |   |   |   |   |   |   | 8                    |                      | PAFZZ       |
| -27                       | 82-61480        | 07700 | SHIELDING GASKET (MAGNAVOX SPEC . . . . .   |   |   |   |   |   |   | 2                    |                      | XB          |
|                           |                 |       | CONT DWG 445994-9)                          |   |   |   |   |   |   |                      |                      |             |
| -28                       | CA111349        | 71468 | CONNECTOR, PLUG (MAGNAVOX SPEC . . . . .    |   |   |   |   |   |   | 1                    |                      | PAFZZ       |
|                           |                 |       | CONT DWG 186188-1)                          |   |   |   |   |   |   |                      |                      |             |
| -29                       | MT4027          | 37695 | REACTOR, POWER (MAGNAVOX SPEC . . . . .     |   |   |   |   |   |   | 1                    |                      | PADZZ       |
|                           |                 |       | CONT DWG 325373-1)                          |   |   |   |   |   |   |                      |                      |             |
| -30                       | MS3213-31       | 96906 | SCREW (AP) . . . . .                        |   |   |   |   |   |   | 4                    |                      | PAFZZ       |
| -31                       | 941183-1        | 37695 | PLATE, GROUNDING . . . . .                  |   |   |   |   |   |   | 1                    |                      | XB          |
| -32                       | 939467-1        | 37695 | PLATE, GROUNDING . . . . .                  |   |   |   |   |   |   | 1                    |                      | XB          |
| -33                       | MS3213-35       | 96906 | SCREW (AP) . . . . .                        |   |   |   |   |   |   | 2                    |                      | PAFZZ       |
|                           | MS21044C3       | 96906 | NUT (AP) . . . . .                          |   |   |   |   |   |   | 2                    |                      | PAFZZ       |
| -34                       | 156014-1*       | 37695 | LABEL . . . . .                             |   |   |   |   |   |   | 1                    |                      | MDD         |
| -35                       | 156014-2*       | 37695 | LABEL . . . . .                             |   |   |   |   |   |   | 1                    |                      | MDD         |
| -36                       | 156014-3*       | 37695 | LABEL . . . . .                             |   |   |   |   |   |   | 1                    |                      | MDD         |
| -37                       | 514891-1        | 37695 | HANDLE, DISTRIBUTION UNIT . . . . .         |   |   |   |   |   |   | 2                    |                      | XB          |
| -38                       | MS16995-26B     | 96906 | SCREW (AP) . . . . .                        |   |   |   |   |   |   | 4                    |                      | PAFZZ       |
| -39                       | 660151-801      | 37695 | CASE, POWER DISTRIBUTION . . . . .          |   |   |   |   |   |   | 1                    |                      | XB          |
| -40                       | MS122118        | 96906 | INSERT . . . . .                            |   |   |   |   |   |   | 7                    |                      | PAFZZ       |
| -41                       | 514892-1        | 37695 | BUSHING, GUIDE PIN . . . . .                |   |   |   |   |   |   | 2                    |                      | XB          |
| -42                       | MS122078        | 96906 | INSERT . . . . .                            |   |   |   |   |   |   | 1                    |                      | XB          |
| -43                       | 660151-1        | 37695 | CASE . . . . .                              |   |   |   |   |   |   | 1                    |                      | XB          |

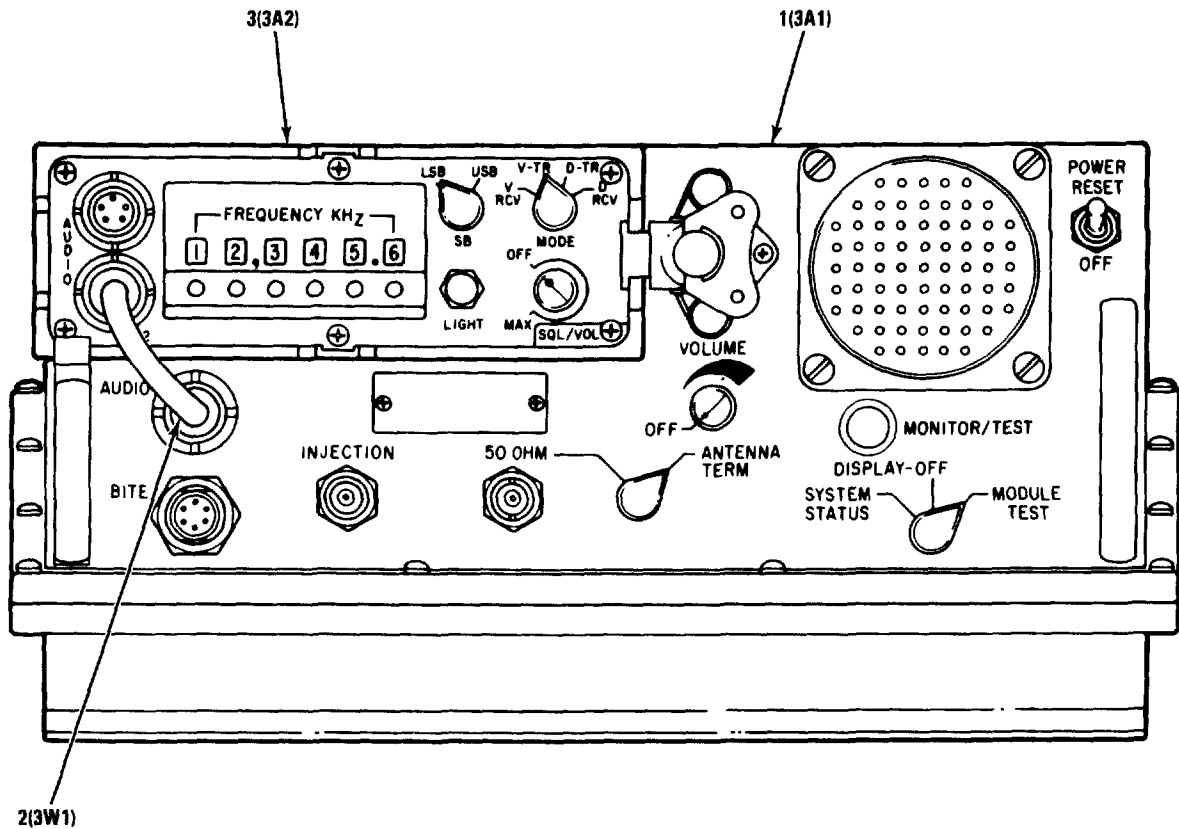

MX-61-119-IPB-16  
 REF MAG DWG 812083 REV -  
 PL 812083 REV B

FIGURE 7-16. RADIO SET, AN/URC-113

**TO 31R2-2GRC206-12**

| FIG. &<br>INDEX<br>NUMBER | PART NUMBER | FSCM  | DESCRIPTION |   |   |   |   |   |   | UNITS<br>PER<br>ASSY | USABLE<br>ON<br>CODE | SMR<br>CODE |
|---------------------------|-------------|-------|-------------|---|---|---|---|---|---|----------------------|----------------------|-------------|
|                           |             |       | 1           | 2 | 3 | 4 | 5 | 6 | 7 |                      |                      |             |
| 7-16-                     | 812083-801  | 37695 |             |   |   |   |   |   |   | REF                  |                      | PAODD       |
|                           |             |       |             |   |   |   |   |   |   |                      |                      |             |
| -1                        | 626701-1#   | 37695 | .           |   |   |   |   |   |   | 1                    |                      | PAODD       |
| -2                        | 566084-806  | 37695 | .           |   |   |   |   |   |   | 1                    |                      | PBOZZ       |
| -3                        | 812118-801# | 37695 | .           |   |   |   |   |   |   | 1                    |                      | AFF         |



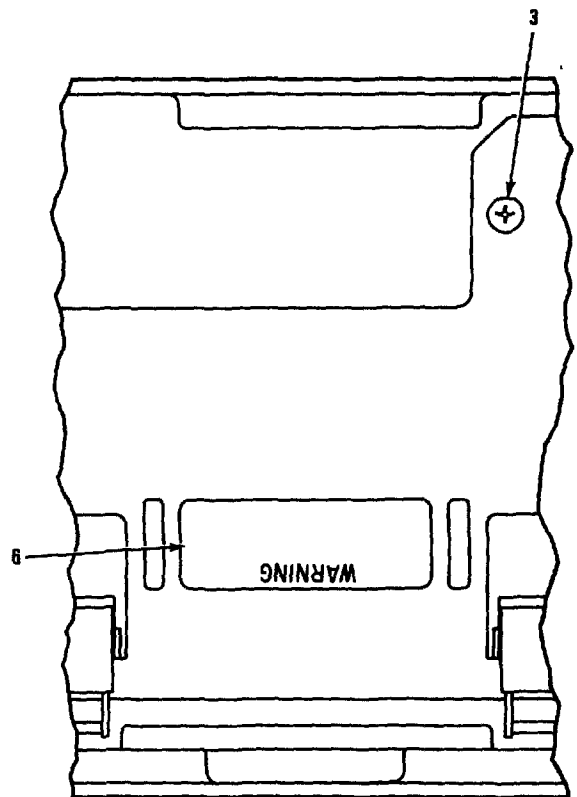
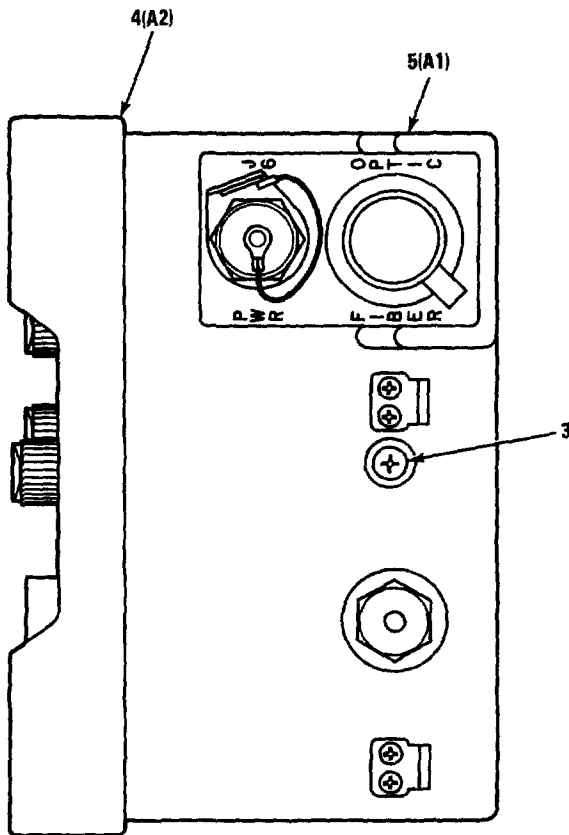
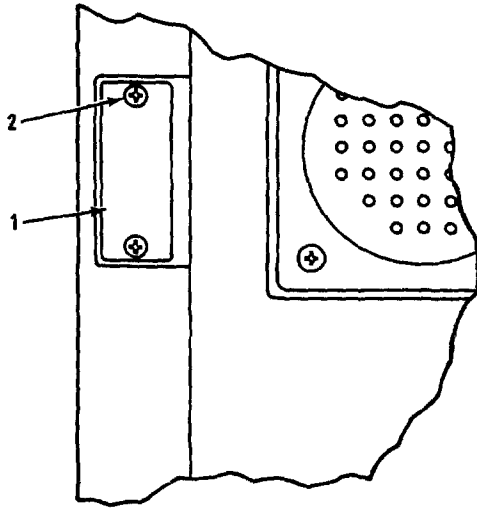

NOTE REFERENCE DESIGNATIONS ARE ABBREVIATED.  
PREFIX WITH 5 OR 6.

MX-61-119-IPB-17  
REF MAG DWG 812085 REV C  
PL 812085 REV F

FIGURE 7-17. RADIO SET CONTROL, C-11166/QRC-206

**TO 31R2-2GRC206-12**

| FIG. &<br>INDEX<br>NUMBER | PART NUMBER | FSCM  | DESCRIPTION   |   |   |   |   |   |   | UNITS<br>PER<br>ASSY | USABLE<br>ON<br>CODE | SMR<br>CODE |
|---------------------------|-------------|-------|---|---|---|---|---|---|---|----------------------|----------------------|-------------|
|                           |             |       | 1   | 2 | 3 | 4 | 5 | 6 | 7 |                      |                      |             |
| 7-17-                     | 812085-801  | 37695 | CONTROL, RADIO SET, C-11166/GRC-206 . . . . .<br>(SEE FIGURE 7-1 FOR NHA) |   |   |   |   |   |   | REF                  |                      | PAODD       |
| ■ -1                      | 155896-*    | 37695 | . PLATE, IDENTIFICATION . . . . .   |   |   |   |   |   |   | 1                    |                      | MDD         |
| -2                        | MS51957-11  | 96906 | . SCREW (AP) . . . . .  |   |   |   |   |   |   | 2                    |                      | PAFZZ       |
| -3                        | MS3213-31   | 96906 | . SCREW . . . . .   |   |   |   |   |   |   | 2                    |                      | PAFZZ       |
| -4                        | 812120-801  | 37695 | . CONTROL, RADIO SET (SEE . . . . .<br>FIGURE 7-18 FOR BKDN)              |   |   |   |   |   |   | 1                    |                      | PAFDD       |
| -5                        | 812092-801  | 37695 | . CASE ASSEMBLY (SEE FIGURE . . . . .<br>7-22 FOR BKDN)                   |   |   |   |   |   |   | 1                    |                      | XB          |
| ■ -6                      | 499914-1*   | 37695 | . LABEL, WARNING . . . . .  |   |   |   |   |   |   | 1                    |                      | MDD         |

MX-61-119-IPB-18-1  
 REF MAG DWG 812120 REV A  
 PL 812120 REV AF

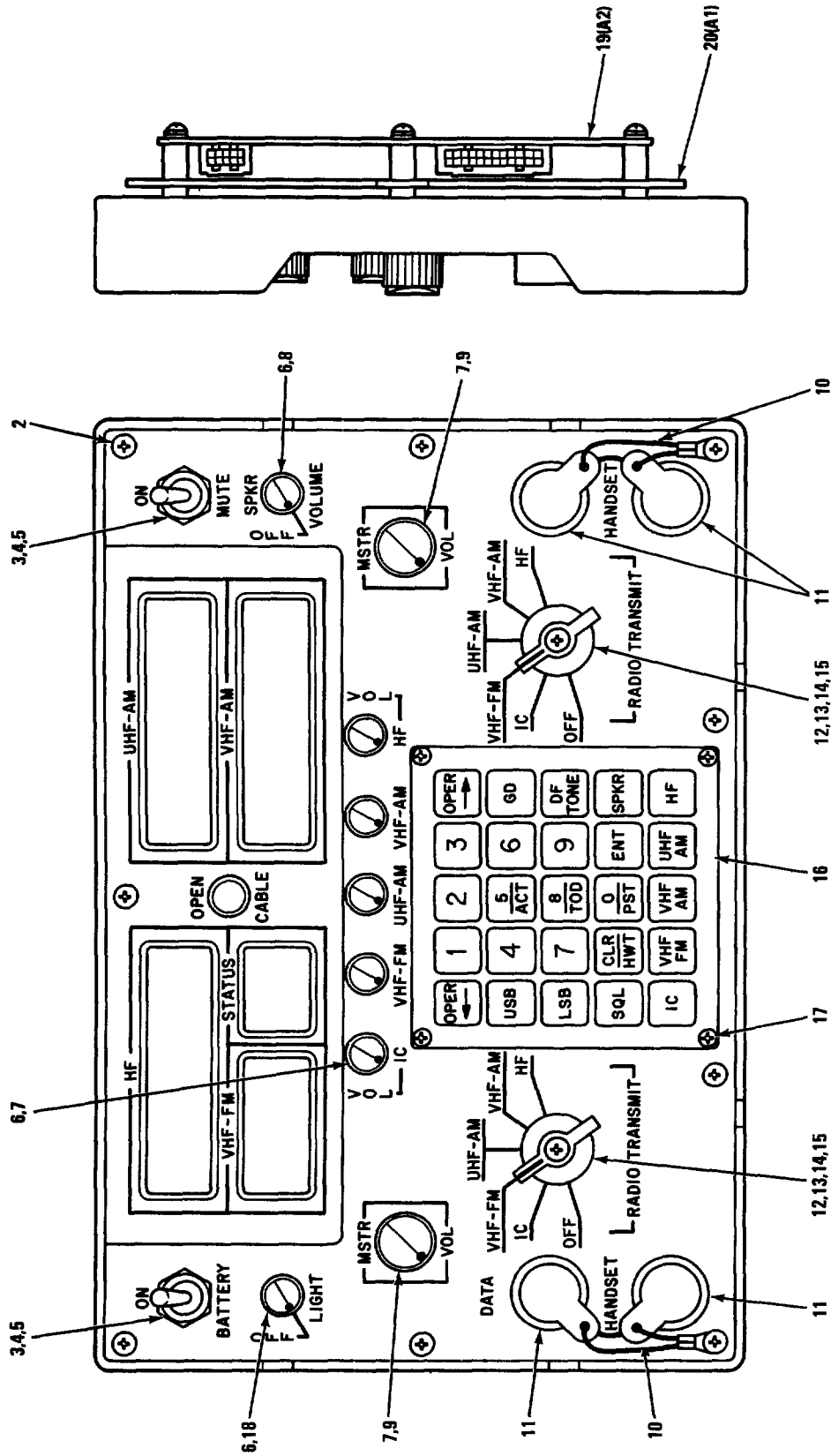

NOTE: REFERENCE DESIGNATIONS ARE ABBREVIATED.  
 PREFIX WITH 5A2 OR 6A2.

FIGURE 7-18. RADIO SET CONTROL (SHEET 1 OF 2)

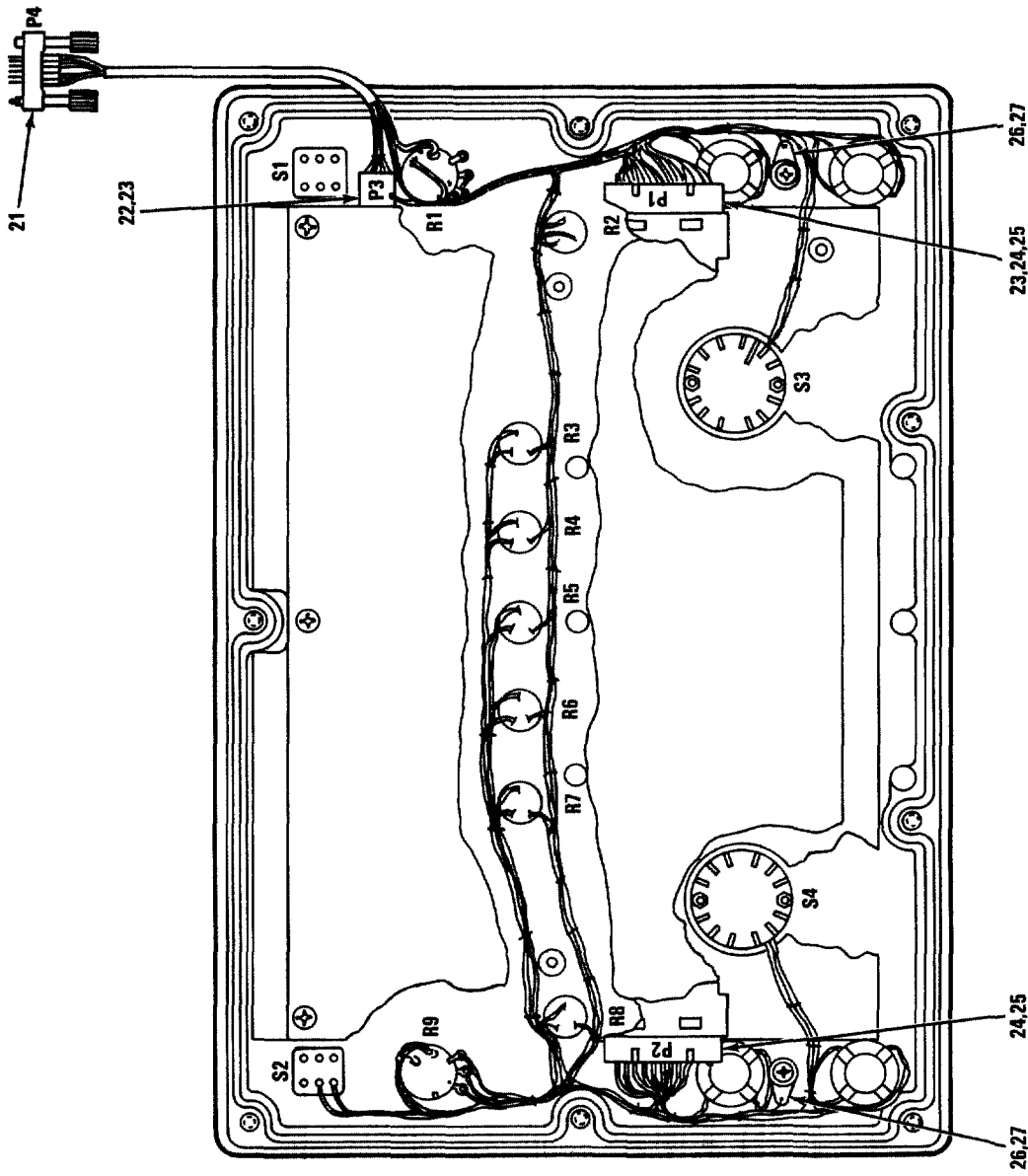

NOTE: REFERENCE DESIGNATIONS ARE ABBREVIATED.  
PREFIX WITH 5A2 OR 6A2.

MX-61-119-IPB-1B-2

FIGURE 7-1B. RADIO SET CONTROL (SHEET 2 OF 2)

| FIG. &<br>INDEX<br>NO. | PART NUMBER     | FSCM<br>1234567 | DESCRIPTION   | UNITS<br>PER<br>ASSY. | USABLE<br>ON<br>CODE | BMR<br>CODE |
|------------------------|-----------------|-----------------|---|-----------------------|----------------------|-------------|
| 7-18-                  | 812120-801      | 37695           | CONTROL, RADIO SET (SEE . . . . .<br>FIGURE 7-17 FOR NHA)           | REF                   |                      | PAFDD       |
| -1                     | 650155-801      | 37695           | PANEL, RADIO SET CONTROL (SEE. . . . .<br>FIGURE 7-21 FOR BKDN)     | 1                     |                      | XB          |
| -2                     | 136555-2        | 37695           | SCREW, MODIFIED (AP) . . . . .                                      | 9                     |                      | XB          |
|                        | NAS620CB        | 80205           | WASHER (AP) . . . . .   | 9                     |                      | PAFZZ       |
| -3                     | MS27719-23      | 96906           | SWITCH, TOGGLE . . . . .  | 2                     |                      | PAFZZ       |
| -4                     | M5423/16-01     | 81349           | SWITCH, ELECTRIC . . . . .  | 2                     |                      | PADZZ       |
| -5                     | M25081C4        | 96906           | WASHER, KEY. . . . .  | 2                     |                      | PAFZZ       |
| -6                     | MS91528-0E1B    | 96906           | KNOB, CONTROL. . . . .  | 7                     |                      | PAFZZ       |
| -7                     | RV68AY8A103C    | 81349           | RESISTOR, VARIABLE . . . . .  | 7                     |                      | PAFZZ       |
| -8                     | CM43842-4       | 50516           | RESISTOR, VARIABLE (MAGNAVOX . . . . .<br>SPEC CONT DWG 228115-4)   | 1                     |                      | PAFZZ       |
| -9                     | MS91528-1E1B    | 96906           | KNOB, CONTROL. . . . .  | 2                     |                      | PAFZZ       |
| -10                    | 813198-801      | 37695           | CONNECTOR, CAP ASSEMBLY. . . . .                                    | 2                     |                      | PAFZZ       |
| -11                    | 814341-801      | 37695           | FILTER, CONNECTOR ASSEMBLY . . . . .                                | 4                     |                      | PAFZZ       |
| -12                    | MS91525-0AW388Z | 96906           | KNOB, CONTROL. . . . .  | 2                     |                      | PAFZZ       |
| -13                    | MS51957-26B     | 96906           | SCREW (AP). . . . .   | 2                     |                      | PAFZZ       |
| -14                    | MS35338-136     | 96906           | WASHER (AP) . . . . .   | 2                     |                      | PAFZZ       |
| -15                    | 5-16421-4       | 76854           | SWITCH, ROTARY (MAGNAVOX SPEC. . . . .<br>CONT DWG 165435-1)        | 2                     |                      | PADZZ       |
| -16                    | 626483-4        | 37695           | KEYBOARD, SEALED . . . . .  | 1                     |                      | PAFZZ       |
| -17                    | MS51957-17B     | 96906           | SCREW (AP). . . . .   | 4                     |                      | PAFZZ       |
|                        | NAS620C4        | 80205           | WASHER (AP) . . . . .   | 4                     |                      | PAFZZ       |
| -18                    | CM43842-7       | 50516           | RESISTOR, VARIABLE (MAGNAVOX . . . . .<br>SPEC CONT DWG 228115-7)   | 1                     |                      | PAFZZ       |
| -19                    | 812133-801      | 37695           | CIRCUIT CARD ASSEMBLY (SEE. . . . .<br>FIGURE 7-19 FOR BKDN)        | 1                     |                      | PAFLD       |
| -20                    | 812126-801      | 37695           | CIRCUIT CARD ASSEMBLY (SEE. . . . .<br>FIGURE 7-20 FOR BKDN)        | 1                     |                      | PAFLD       |
| -21                    | M28748/7B0081A  | 81349           | CONNECTOR, RECEPTACLE. . . . .                                      | 1                     |                      | PADZZ       |
| -22                    | 102241-3        | 00779           | CONNECTOR, BODY PLUG (MAGNAVOX . . . . .<br>SPEC CONT DWG 186313-1) | 1                     |                      | PADZZ       |
| -23                    | 87046-3         | 00779           | CONTACT, ELECTRICAL (MAGNAVOX. . . . .<br>SPEC CONT DWG 165338-5)   | 9                     |                      | PADZZ       |
| -24                    | 2-87631-2       | 00779           | CONNECTOR, BODY PLUG (MAGNAVOX . . . . .<br>SPEC CONT DWG 185971-1) | 2                     |                      | PADZZ       |
| -25                    | 87045-3         | 00779           | CONTACT, ELECTRICAL (MAGNAVOX. . . . .<br>SPEC CONT DWG 165338-1)   | 50                    |                      | PADZZ       |
| -26                    | MS77068-1       | 96906           | TERMINAL. . . . .   | 2                     |                      | PADZZ       |
| -27                    | MS51957-13      | 96906           | SCREW (AP). . . . .   | 2                     |                      | PAFZZ       |

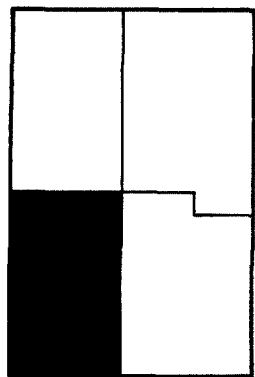

NOTE: REFERENCE DESIGNATIONS ARE ABBREVIATED.  
PREFIX WITH 5A2A2 or 6A2A2.

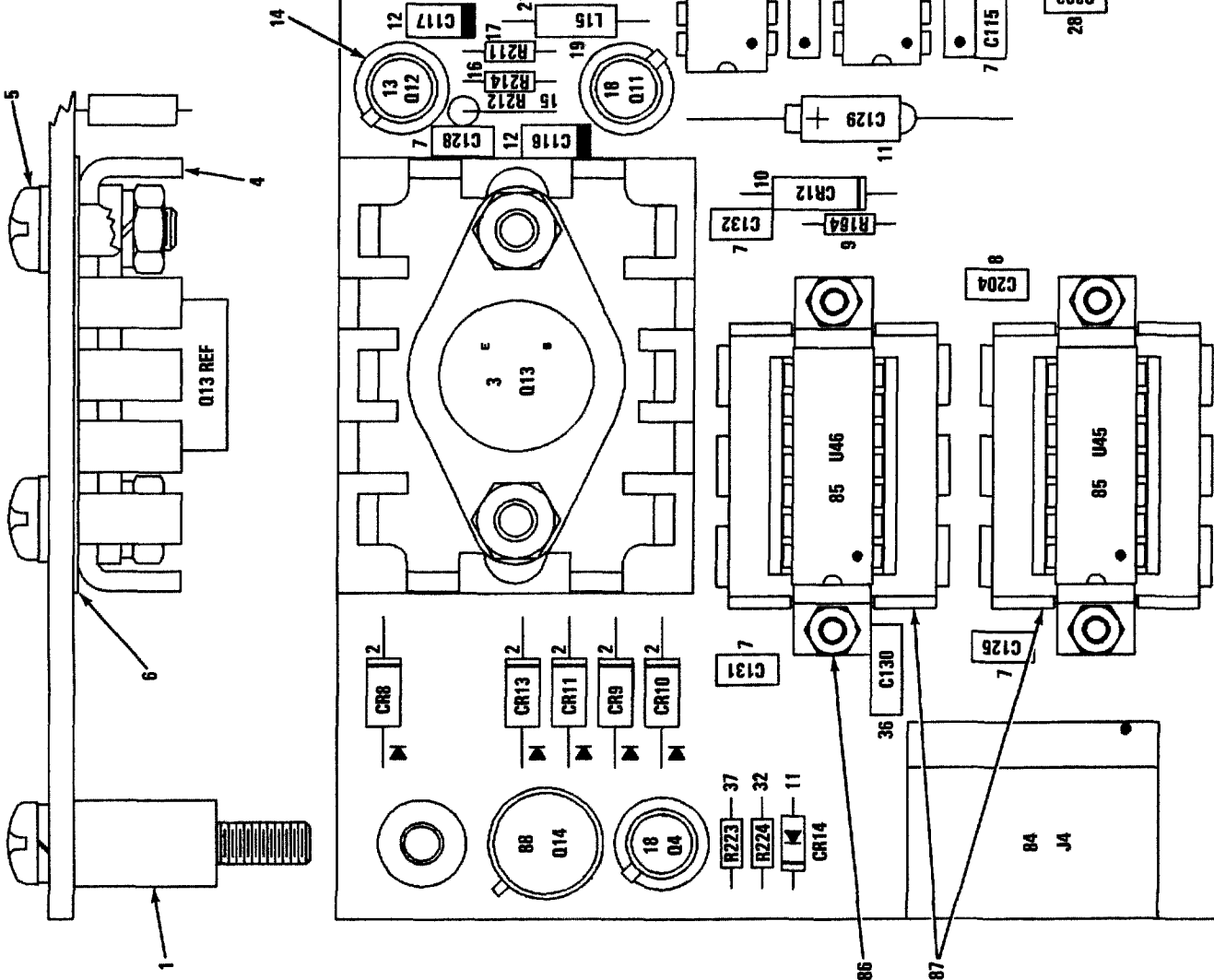

MX-61-119-IPB-15-1  
REF MAG DWG 812133 REV M  
PL 812133 REV AK

FIGURE 7-19. CIRCUIT CARD ASSEMBLY (SHEET 1 OF 4)

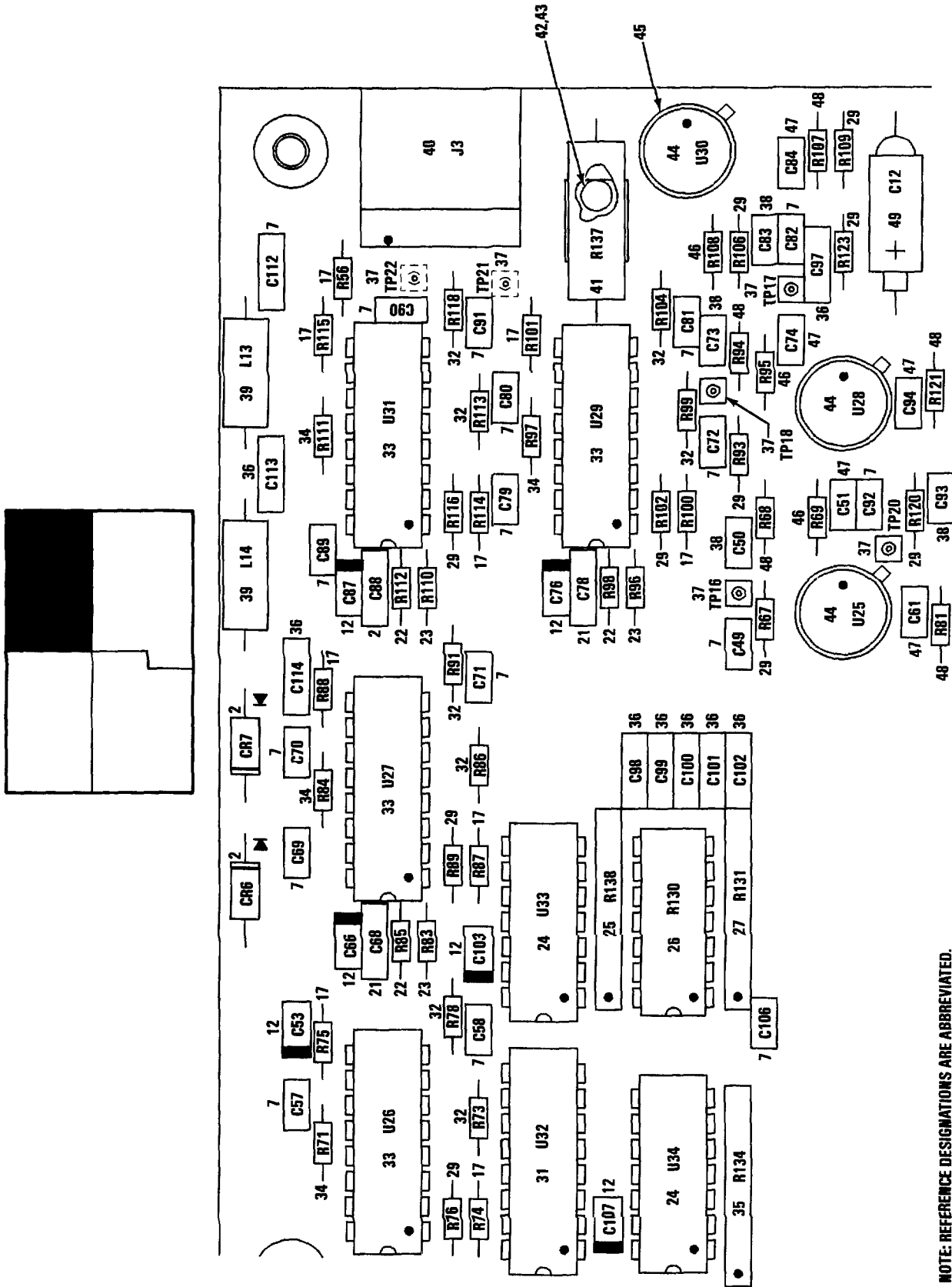

MX-61-119-IPB-19-2

NOTE: REFERENCE DESIGNATIONS ARE ABBREVIATED. PREFIX WITH 5A2A2 or 6A2A2.

FIGURE 7-19. CIRCUIT CARD ASSEMBLY (SHEET 2 OF 4)

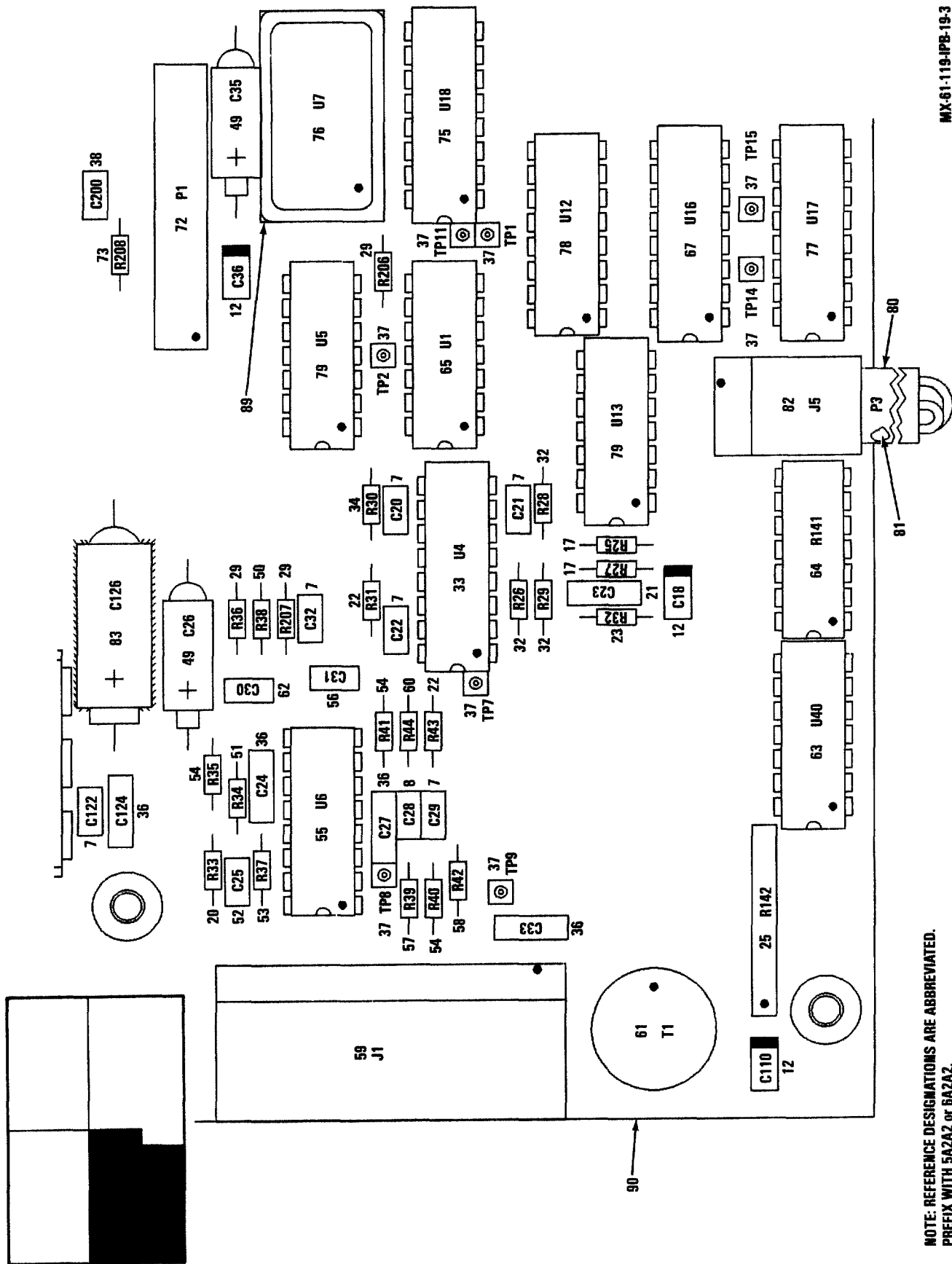

NOTE: REFERENCE DESIGNATIONS ARE ABBREVIATED.  
PREFIX WITH 5A2A2 or 6A2A2.

FIGURE 7-19. CIRCUIT CARD ASSEMBLY (SHEET 3 OF 4)

MX-61-119-IPB-19-3



NOTE: REFERENCE DESIGNATIONS ARE ABBREVIATED.  
PREFIX WITH 5A2A2 or 6A2A2.

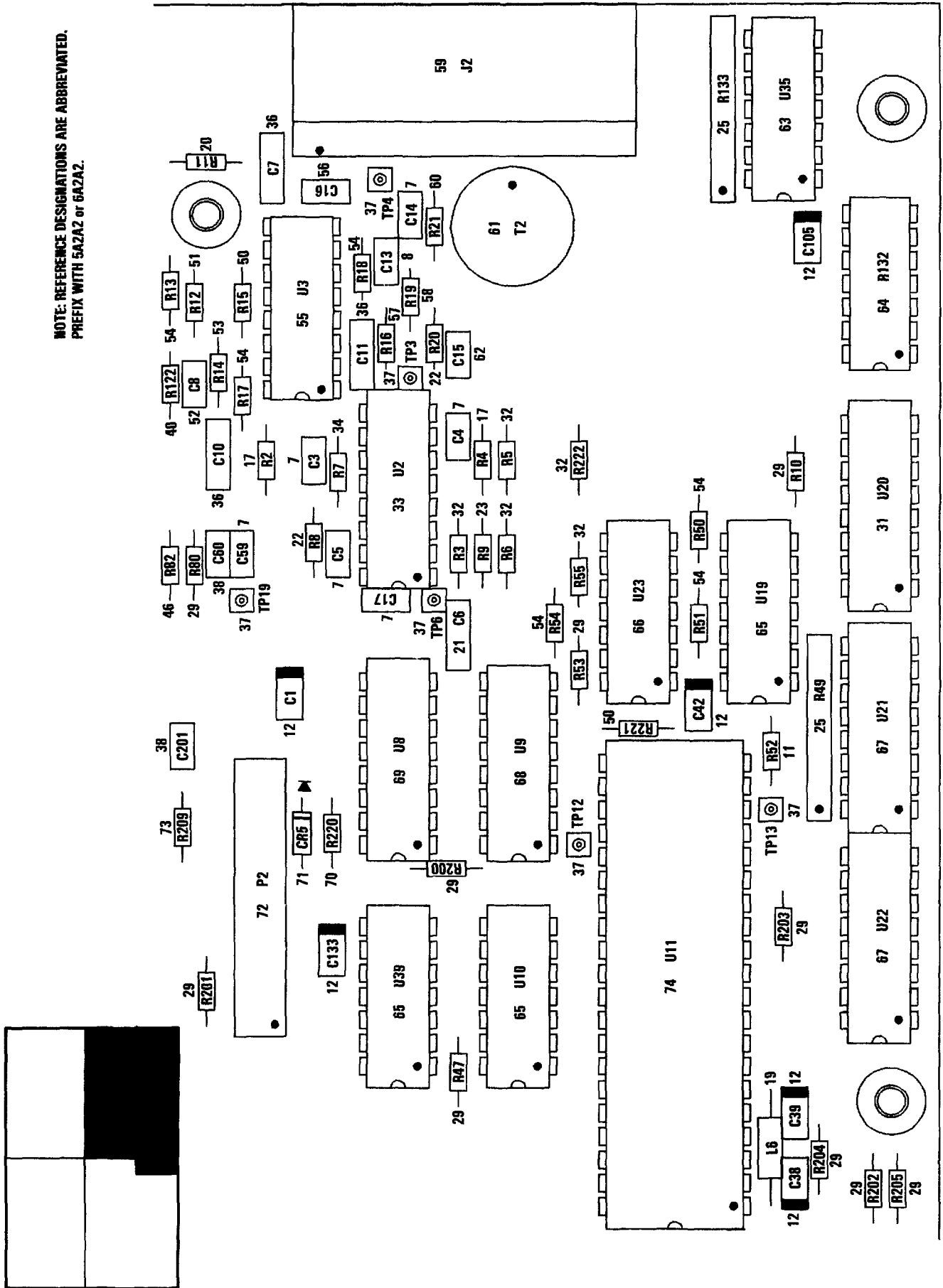

MX-61-119-IPB-19-4

FIGURE 7-19. CIRCUIT CARD ASSEMBLY (SHEET 4 OF 4)

| FIG. & INDEX NO. | PART NUMBER       | FSCM 1234567 | DESCRIPTION  | UNITS PER ASSY. | USABLE ON CODE | SMR CODE |
|------------------|-------------------|--------------|--|-----------------|----------------|----------|
| 7-19-            | B12133-801        | 37695        | CIRCUIT CARD ASSEMBLY (SEE . . . . .<br>. FIGURE 7-18 FOR NHA) | REF             |                | PAFLD    |
| -1               | 136597-3          | 37695        | . SCREW, MODIFIED. . . . .                                     | 8               |                | XB       |
|                  | MS35338-136       | 96906        | . WASHER. . . . .  | 8               |                | PAFZZ    |
|                  | 136602-1          | 37695        | . NUT, SLEEVE. . . . .   | 8               |                | XB       |
| -2               | JANTX1N5616       | 81349        | . SEMICONDUCTOR DEVICE. . . . .                                | 7               |                | PADZZ    |
| -3               | JANTX2N6298       | 81349        | . SEMICONDUCTOR DEVICE(ESDS). . . . .                          | 1               |                | PADZZ    |
| -4               | LB66B2            | 98978        | . HEAT SINK (MAGNAVOX SPEC CONT<br>DWG 435676-1)               | 1               |                | XB       |
| -5               | MS51957-29        | 96906        | . SCREW (AP). . . . .  | 2               |                | PAFZZ    |
|                  | NAS620C6          | 80205        | . WASHER (AP) . . . . .  | 2               |                | PAFZZ    |
|                  | MS35338-136       | 96906        | . WASHER (AP) . . . . .  | 2               |                | PAFZZ    |
|                  | NAS671C6          | 80205        | . NUT (AP). . . . .  | 2               |                | PAFZZ    |
| -6               | 348625-1          | 37695        | . INSULATOR, HEAT SINK . . . . .                               | 1               |                | XB       |
| -7               | M39014/01-1473    | 81349        | . CAPACITOR . . . . .  | 38              |                | PADZZ    |
| -8               | M39014/01-1227    | 81349        | . CAPACITOR . . . . .  | 3               |                | PADZZ    |
| -9               | RCR0502R7JS       | 81349        | . RESISTOR. . . . .  | 1               |                | PADZZ    |
| -10              | 616384-905        | 37695        | . SEMICONDUCTOR DEVICE. . . . .                                | 1               |                | PADZZ    |
| -11              | M39003/01-3076    | 81349        | . CAPACITOR . . . . .  | 1               |                | PADZZ    |
|                  | *M39003/01-2356   | 81349        | . CAPACITOR . . . . .  | 1               |                | PADZZ    |
| -12              | 275056-3242       | 37695        | . CAPACITOR . . . . .  | 20              |                | PADZZ    |
| -13              | JANTX2N2222A      | 81349        | . SEMICONDUCTOR DEVICE. . . . .                                | 2               |                | PADZZ    |
| -14              | 10398-N           | 07047        | . INSULATOR, TRANSISTOR (MAGNAVOX.<br>SPEC CONT DWG 447419-9)  | 4               |                | XB       |
| -15              | RWR81S1001FR      | 81349        | . RESISTOR. . . . .  | 1               |                | PADZZ    |
| -16              | RCR050101JS       | 81349        | . RESISTOR. . . . .  | 1               |                | PADZZ    |
| -17              | RCR050102JS       | 81349        | . RESISTOR. . . . .  | 18              |                | PADZZ    |
| -18              | JANTX2N2907A      | 81349        | . SEMICONDUCTOR DEVICE. . . . .                                | 2               |                | PADZZ    |
| -19              | MS75085-19        | 96906        | . COIL. . . . .  | 2               |                | PADZZ    |
| -20              | RCR050151JS       | 81349        | . RESISTOR. . . . .  | 3               |                | PADZZ    |
| -21              | M39014/02-1354    | 81349        | . CAPACITOR . . . . .  | 7               |                | PADZZ    |
|                  | *M39014/02-1234   | 81349        | . CAPACITOR . . . . .  | 7               |                | PADZZ    |
| -22              | RCR050393JS       | 81349        | . RESISTOR. . . . .  | 9               |                | PADZZ    |
| -23              | RCR050155JS       | 81349        | . RESISTOR. . . . .  | 7               |                | PADZZ    |
| -24              | 616146-901        | 37695        | . MICROCIRCUIT, DIGITAL(ESDS). . . . .                         | 4               |                | PADZZ    |
|                  | =M38510/05851BCB  | 81349        | . MICROCIRCUIT(ESDS). . . . .                                  | 4               |                | PADZZ    |
|                  | *JM38510/05851BCX | 81349        | . MICROCIRCUIT(ESDS). . . . .                                  | 4               |                | PADZZ    |
| -25              | M8340105M10030C   | 81349        | . RESISTOR. . . . .  | 5               |                | PADZZ    |
| -26              | M8340101M36020A   | 81349        | . RESISTOR. . . . .  | 2               |                | PADZZ    |
| -27              | M8340105M68020C   | 81349        | . RESISTOR. . . . .  | 2               |                | PADZZ    |
| -28              | M39014/01-1562    | 81349        | . CAPACITOR . . . . .  | 2               |                | PADZZ    |
|                  | *M39014/01-1442   | 81349        | . CAPACITOR . . . . .  | 2               |                | PADZZ    |
| -29              | RCR050104JS       | 81349        | . RESISTOR. . . . .  | 26              |                | PADZZ    |
| -30              | RCR050113JS       | 81349        | . RESISTOR. . . . .  | 1               |                | PADZZ    |
| -31              | 7702501EX         | 14933        | . MICROCIRCUIT (MAGNAVOX SPEC<br>CONT DWG 616175-901)(ESDS)    | 3               |                | PADZZ    |
| -32              | RCR050103JS       | 81349        | . RESISTOR. . . . .  | 20              |                | PADZZ    |
| -33              | 617788-901        | 37695        | . MICROCIRCUIT, LINEAR . . . . .                               | 7               |                | PADZZ    |
| -34              | RCR050682JS       | 81349        | . RESISTOR. . . . .  | 7               |                | PADZZ    |
| -35              | M8340105K12030C   | 81349        | . RESISTOR. . . . .  | 1               |                | PADZZ    |
| -36              | M39014/02-1419    | 81349        | . CAPACITOR . . . . .  | 16              |                | PADZZ    |
|                  | *M39014/02-1407   | 81349        | . CAPACITOR . . . . .  | 16              |                | PADZZ    |
| -37              | 186095-1          | 37695        | . CONNECTOR, STRIP . . . . .                                   | 20              |                | PADZZ    |
| -38              | M39014/01-1575    | 81349        | . CAPACITOR . . . . .  | 7               |                | PADZZ    |
|                  | *M39014/01-1455   | 81349        | . CAPACITOR . . . . .  | 7               |                | PADZZ    |
| -39              | M39010/3A150KP    | 81349        | . COIL(ESDS). . . . .  | 2               |                | PADZZ    |
| -40              | 518B-244-2        | 00779        | . CONNECTOR, RECEPTACLE (MAGNAVOX.<br>SPEC CONT DWG 186370-1)  | 1               |                | PADZZ    |
| -41              | RWR89S42R2FR      | 81349        | . RESISTOR. . . . .  | 1               |                | PADZZ    |
| -42              | M24066/2-213      | 81349        | . CLIP, SOLID, SPRING . . . . .                                | 1               |                | XB       |
| -43              | MS16535-12        | 96906        | . RIVET (AP). . . . .  | 2               |                | XB       |
| -44              | 616139-901        | 37695        | . MICROCIRCUIT, LINEAR . . . . .                               | 3               |                | PADZZ    |
| -45              | M38527/02D        | 81349        | . MOUNTING PAD, INSULATOR. . . . .                             | 4               |                | XB       |
| -46              | RCR050272JS       | 81349        | . RESISTOR. . . . .  | 5               |                | PADZZ    |
| -47              | M39014/01-1353    | 81349        | . CAPACITOR . . . . .  | 5               |                | PADZZ    |
|                  | *M39014/01-1233   | 81349        | . CAPACITOR . . . . .  | 5               |                | PADZZ    |
| -48              | RCR050473JS       | 81349        | . RESISTOR. . . . .  | 5               |                | PADZZ    |
| -49              | M39003/01-3006    | 81349        | . CAPACITOR . . . . .  | 3               |                | PADZZ    |
|                  | *M39003/01-2286   | 81349        | . CAPACITOR . . . . .  | 3               |                | PADZZ    |

| FIG. & INDEX NO. | PART NUMBER       | FSCM  | 1234567 | DESCRIPTION  | UNITS PER ASSY. | USABLE ON CODE | SMR CODE |
|------------------|-------------------|-------|---------|--|-----------------|----------------|----------|
| 7-19-50          | RCR050754JS       | 81349 |         | RESISTOR.  | 3               |                | PADZZ    |
| -51              | RCR050472JS       | 81349 |         | RESISTOR.  | 2               |                | PADZZ    |
| -52              | M39014/01-1341    | 81349 |         | CAPACITOR  | 2               |                | PADZZ    |
|                  | *M39014/01-1221   | 81349 |         | CAPACITOR  | 2               |                | PADZZ    |
| -53              | RCR050753JS       | 81349 |         | RESISTOR.  | 2               |                | PADZZ    |
| -54              | RCR050513JS       | 81349 |         | RESISTOR.  | 9               |                | PADZZ    |
| -55              | 616325-901        | 37695 |         | MICROCIRCUIT, LINEAR   | 2               |                | PADZZ    |
| -56              | M39014/01-1357    | 81349 |         | CAPACITOR  | 2               |                | PADZZ    |
|                  | *M39014/01-1237   | 81349 |         | CAPACITOR  | 2               |                | PADZZ    |
| -57              | RCR050512JS       | 81349 |         | RESISTOR.  | 2               |                | PADZZ    |
| -58              | RCR050822JS       | 81349 |         | RESISTOR.  | 2               |                | PADZZ    |
| -59              | 5188-244-4        | 00779 |         | CONNECTOR, RECEPTACLE (MAGNAVOX. SPEC CONT DWG 186370-3)       | 2               |                | PADZZ    |
| -60              | RCR050471JS       | 81349 |         | RESISTOR.  | 2               |                | PADZZ    |
| -61              | PICO-3776         | 31669 |         | TRANSFORMER, AUDIO FREQUENCY (MAGNAVOX SPEC CONT DWG 325335-1) | 2               |                | PADZZ    |
| -62              | M39014/01-1587    | 81349 |         | CAPACITOR  | 2               |                | PADZZ    |
|                  | *M39014/01-1467   | 81349 |         | CAPACITOR  | 2               |                | PADZZ    |
| -63              | 7705601CX         | 14933 |         | MICROCIRCUIT (MAGNAVOX SPEC CONT DWG 615762-901)(ESDS)         | 2               |                | PADZZ    |
| -64              | M3840101M20020A   | 81349 |         | RESISTOR.  | 2               |                | PADZZ    |
| -65              | 616492-901        | 37695 |         | MICROCIRCUIT, DIGITAL (ESDS)                                   | 4               |                | PADZZ    |
|                  | =JM38510/05051BCX | 81349 |         | MICROCIRCUIT (ESDS)  | 4               |                | PADZZ    |
| -66              | 615506-901        | 37695 |         | MICROCIRCUIT, LINEAR (ESDS)                                    | 1               |                | PADZZ    |
|                  | =M38510/11201BCB  | 81349 |         | MICROCIRCUIT (ESDS)  | 1               |                | PADZZ    |
|                  | *JM38510/11201BCX | 81349 |         | MICROCIRCUIT (ESDS)  | 1               |                | PADZZ    |
| -67              | 616670-901        | 37695 |         | MICROCIRCUIT, DIGITAL (ESDS)                                   | 3               |                | PADZZ    |
| -68              | 616521-902        | 37695 |         | MICROCIRCUIT, DIGITAL (ESDS)                                   | 1               |                | PADZZ    |
|                  | =JM38510/05753BEX | 81349 |         | MICROCIRCUIT (ESDS)  | 1               |                | PADZZ    |
| -69              | 7705801EX         | 14933 |         | MICROCIRCUIT (MAGNAVOX SPEC CONT DWG 615745-901)(ESDS)         | 1               |                | PADZZ    |
| -70              | RCR050394JS       | 81349 |         | RESISTOR.  | 1               |                | PADZZ    |
| -71              | JANTX1N4454-1     | 81349 |         | SEMICONDUCTOR DEVICE.  | 2               |                | PADZZ    |
| -72              | 5188-590-12       | 00779 |         | CONNECTOR, RECEPTACLE (MAGNAVOX. SPEC CONT DWG 185763-215)     | 2               |                | PADZZ    |
| -73              | RCR050624JS       | 81349 |         | RESISTOR.  | 2               |                | PADZZ    |
| -74              | 7901701GX         | 14933 |         | MICROCIRCUIT (MAGNAVOX SPEC CONT DWG 645513-901)(ESDS)         | 1               |                | PADZZ    |
| -75              | CD40168MJ/883B    | 27014 |         | MICROCIRCUIT (MAGNAVOX SPEC CONT DWG 645513-901)(ESDS)         | 1               |                | PADZZ    |
| -76              | T213-3. 2 MHZ     | 57051 |         | OSCILLATOR, CRYSTAL (MAGNAVOX. SPEC CONT DWG 626734-1)         | 1               |                | PADZZ    |
| -77              | 615677-901        | 37695 |         | MICROCIRCUIT, DIGITAL (ESDS)                                   | 1               |                | PADZZ    |
| -78              | 616506-901        | 37695 |         | MICROCIRCUIT, DIGITAL (ESDS)                                   | 1               |                | PADZZ    |
|                  | =JM38510/05553BEX | 81349 |         | MICROCIRCUIT (ESDS)  | 1               |                | PADZZ    |
| -79              | 616501-901        | 37695 |         | MICROCIRCUIT, DIGITAL (ESDS)                                   | 2               |                | PADZZ    |
|                  | =JM38510/05151BCX | 81349 |         | MICROCIRCUIT (ESDS)  | 2               |                | PADZZ    |
| -80              | 87631-2           | 00779 |         | CONNECTOR, RECEPTACLE (MAGNAVOX. SPEC CONT DWG 185971-9)       | 1               |                | PADZZ    |
| -81              | 87046-3           | 00779 |         | CONTACT, ELECTRICAL (MAGNAVOX. SPEC CONT DWG 165338-5)         | 6               |                | PADZZ    |
| -82              | 5188-244-5        | 00779 |         | CONNECTOR, RECEPTACLE (MAGNAVOX. SPEC CONT DWG 186370-4)       | 1               |                | PADZZ    |
| -83              | M39003/03-0384    | 81349 |         | CAPACITOR  | 1               |                | PADZZ    |
|                  | *M39003/03-0184   | 81349 |         | CAPACITOR  | 1               |                | PADZZ    |
| -84              | 5188-244-3        | 00779 |         | CONNECTOR, RECEPTACLE (MAGNAVOX. SPEC CONT DWG 186370-2)       | 1               |                | PADZZ    |
| -85              | 619905-901        | 37695 |         | INTEGRATED CIRCUIT.  | 2               |                | PADZZ    |
| -86              | M851957-4         | 96906 |         | SCREW (AP).  | 4               |                | PAFZZ    |
|                  | M83533B-134       | 96906 |         | WASHER (AP)  | 4               |                | PAFZZ    |
|                  | NAS620C2          | 80205 |         | WASHER (AP)  | 4               |                | PAFZZ    |
|                  | NAS671C2          | 80205 |         | NUT (AP).  | 4               |                | PAFZZ    |
| -87              | 6007              | 13103 |         | HEAT SINK (MAGNAVOX SPEC CONT DWG 435652-2)                    | 2               |                | XB       |
| -88              | JANTX2N3467       | 81349 |         | SEMICONDUCTOR DEVICE.  | 1               |                | PADZZ    |
| -89              | 348559-1          | 37695 |         | INSULATOR, OSCILLATOR.   | 1               |                | XB       |
| -90              | 412050-1          | 37695 |         | PRINTED WIRING BOARD.  | 1               |                | XB       |

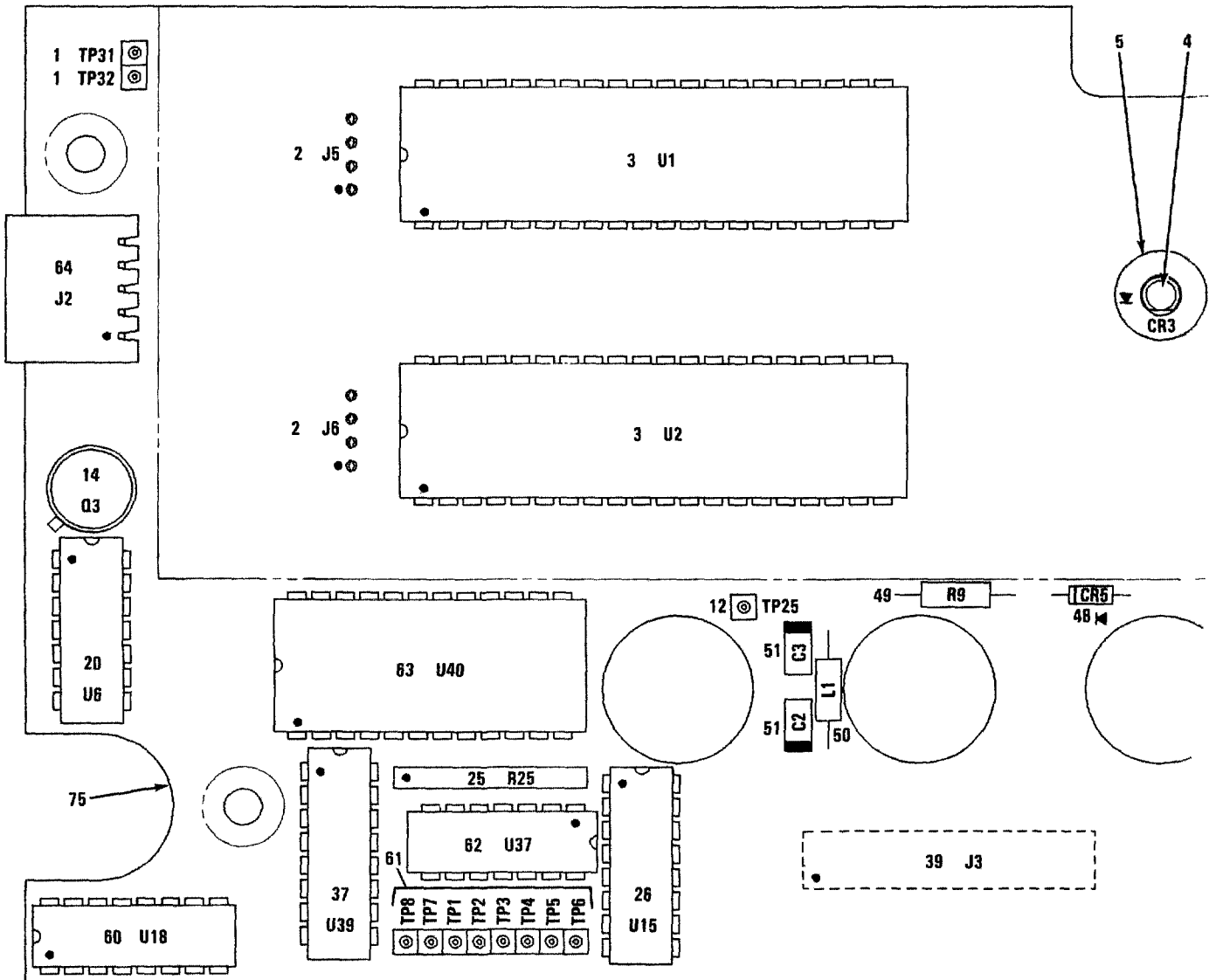
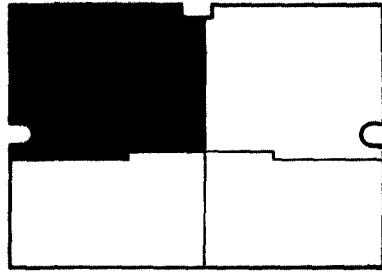

NOTE: REFERENCE DESIGNATIONS ARE ABBREVIATED.  
PREFIX WITH 5A2A1 OR 6A2A1.

MX-61-119-IPB-20-1  
REF MAG DWG 812126 REV M  
PL 812126 REV AJ

FIGURE 7-20. CIRCUIT CARD ASSEMBLY (SHEET 1 OF 5)

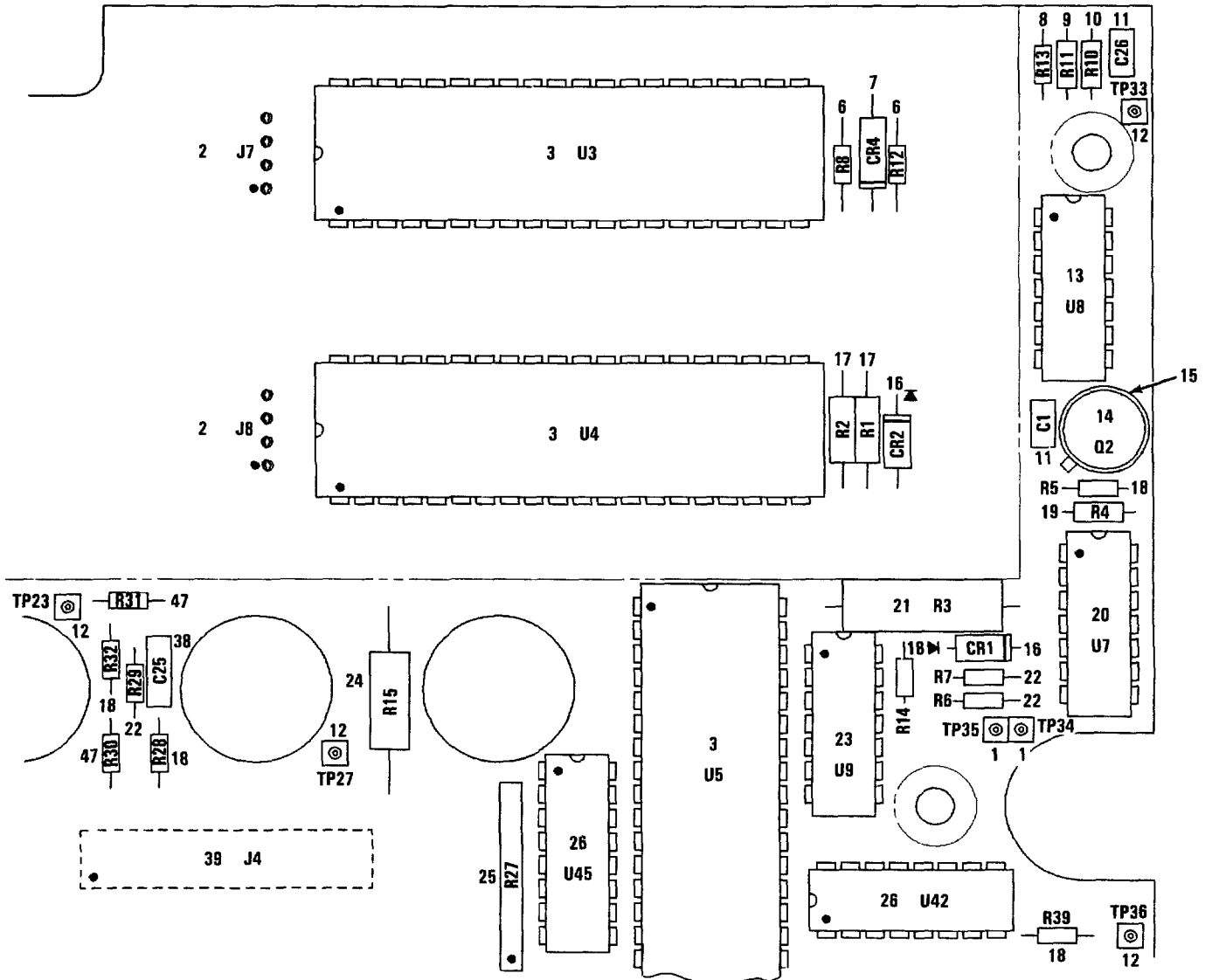
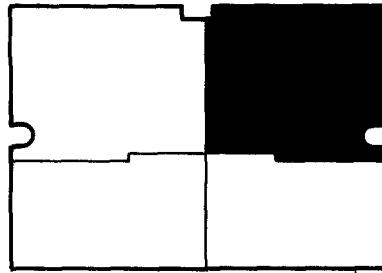

NOTE: REFERENCE DESIGNATIONS ARE ABBREVIATED.  
 PREFIX WITH 5A2A1 OR 6A2A1.

MX-61-119-IP8-20-2

FIGURE 7-20. CIRCUIT CARD ASSEMBLY (SHEET 2 OF 5)

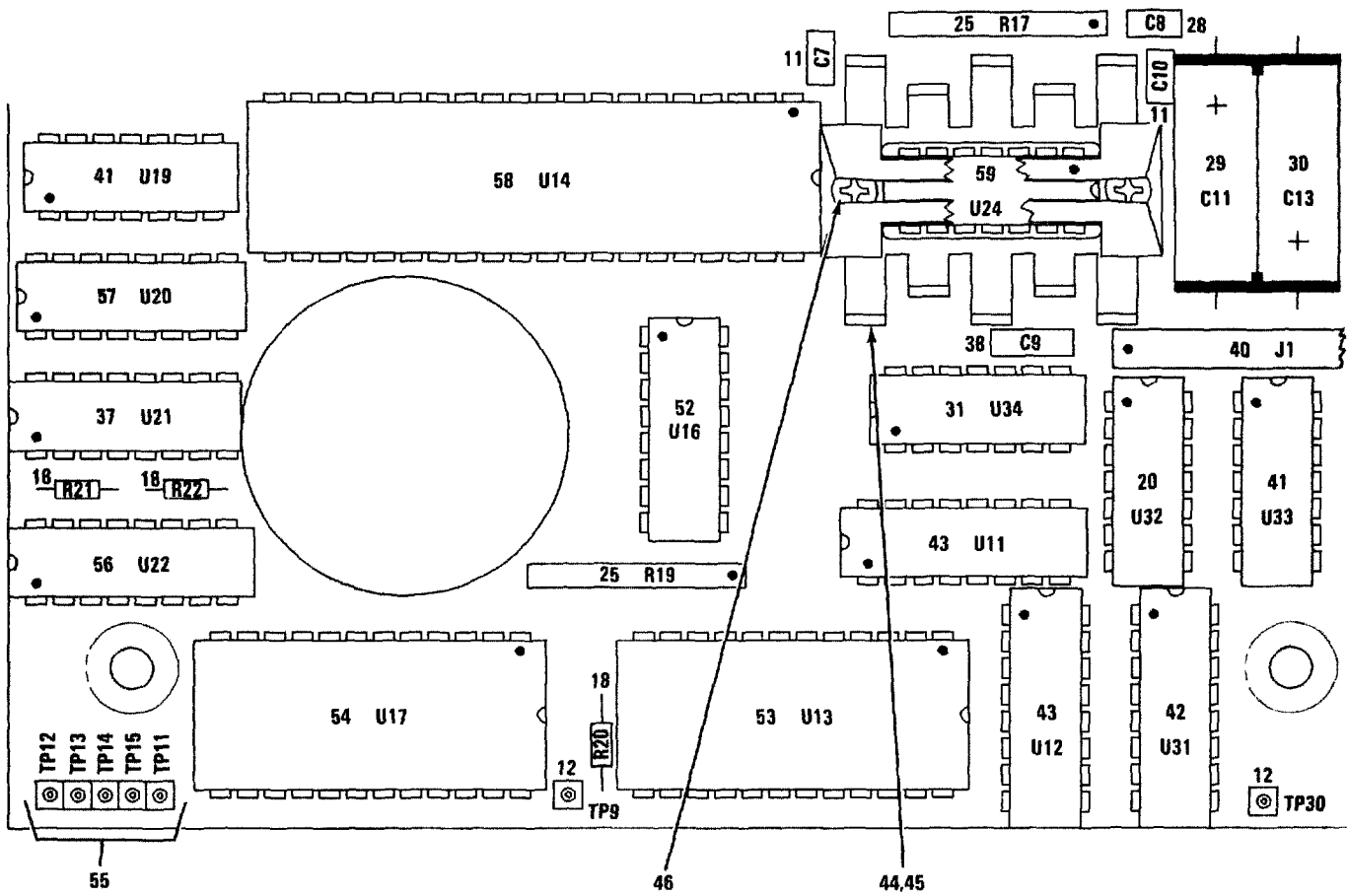
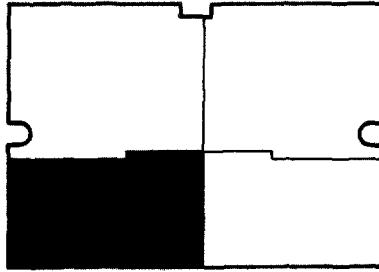

NOTE: REFERENCE DESIGNATIONS ARE ABBREVIATED.  
 PREFIX WITH 5A2A1 OR 6A2A1.

MX-61-119-IPB-20-3

FIGURE 7-20. CIRCUIT CARD ASSEMBLY (SHEET 3 OF 5)

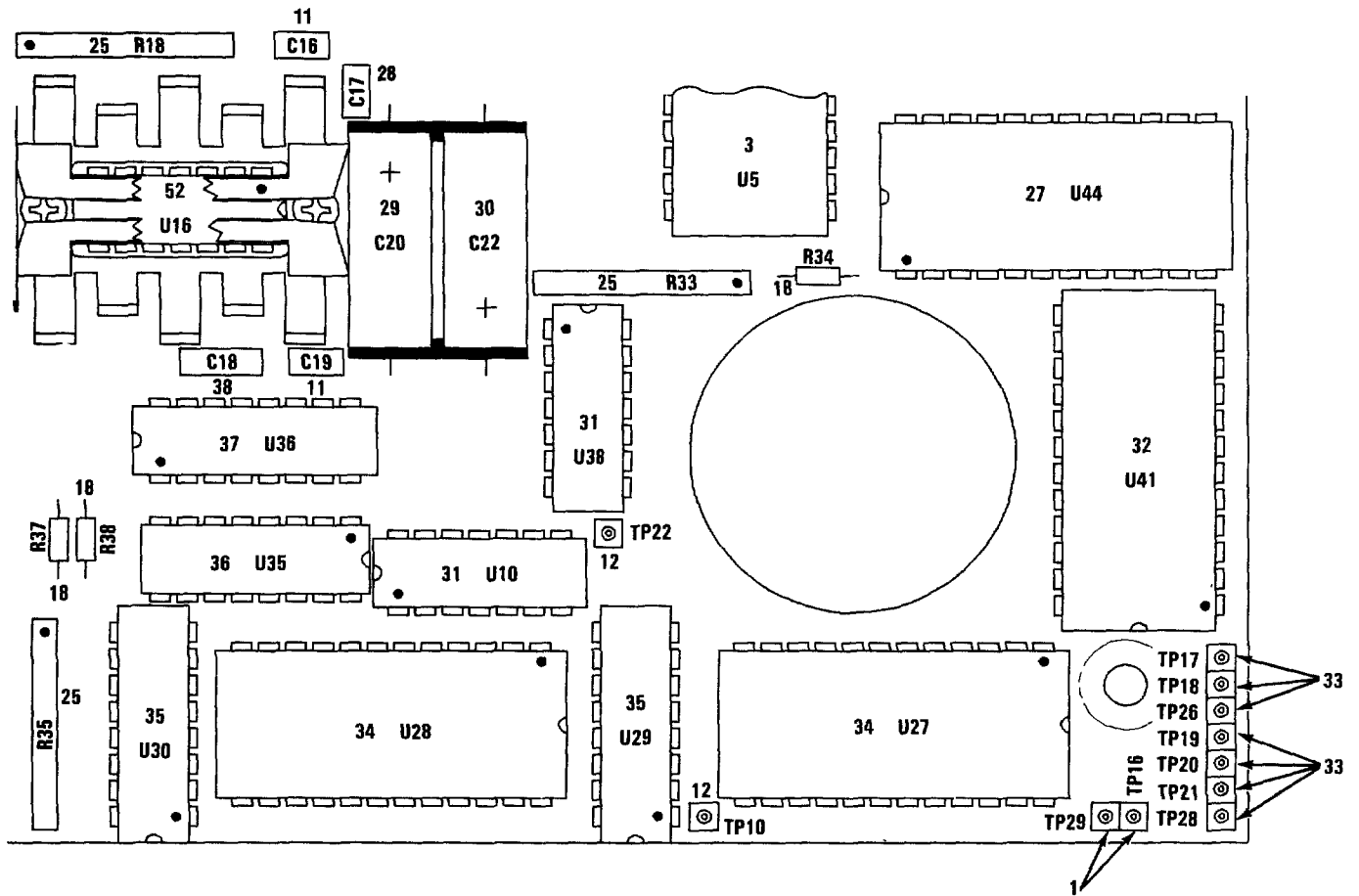
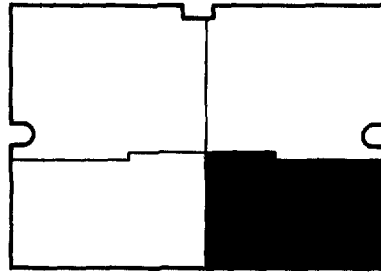

NOTE: REFERENCE DESIGNATIONS ARE ABBREVIATED.  
 PREFIX WITH 5A2A1 OR 6A2A1.

MX-61-119-IPB-20-4

FIGURE 7-20. CIRCUIT CARD ASSEMBLY (SHEET 4 OF 5)

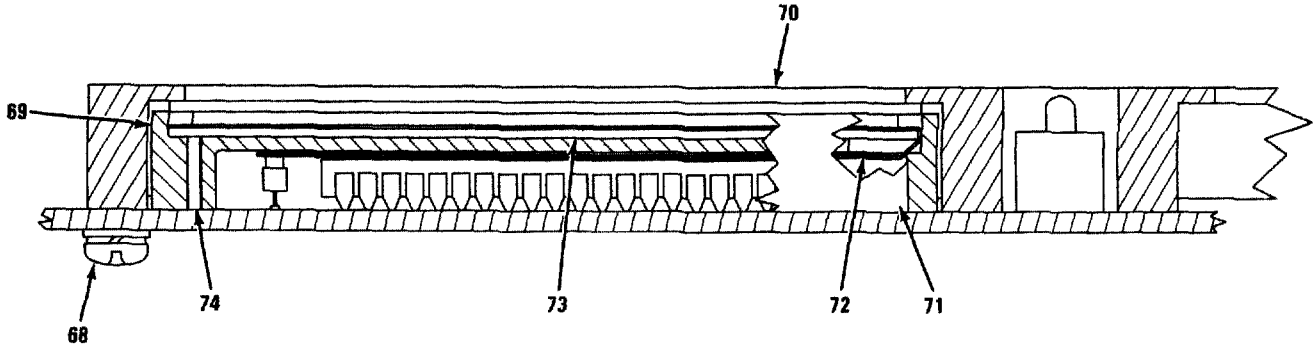

VIEW A-A

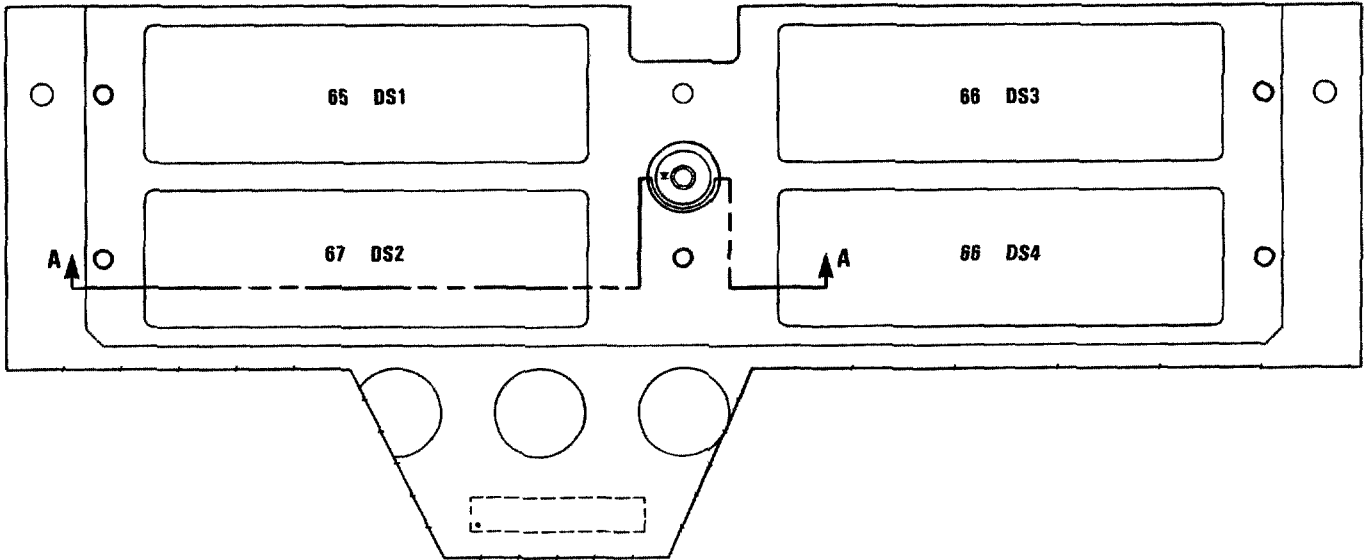

NOTE: REFERENCE DESIGNATIONS ARE ABBREVIATED.  
PREFIX WITH 5A2A1 OR 6A2A1.

MX-61-119-IPB-20-5

FIGURE 7-20. CIRCUIT CARD ASSEMBLY (SHEET 5 OF 5)



| FIG. & INDEX ND. | PART NUMBER       | FSCM 1234567 | DESCRIPTION  | UNITS PER ASSY. | USABLE ON CODE | SMR CODE |
|------------------|-------------------|--------------|--|-----------------|----------------|----------|
| 7-20-            | 812126-801        | 37695        | CIRCUIT CARD ASSEMBLY (SEE . . . . .<br>FIGURE 7-18 FOR NHA)           | REF             |                | PAFLD    |
| -1               | 186095-2          | 37695        | . CONNECTOR, STRIP . . . . .   | 3               |                | PADZZ    |
| -2               | M83505/6-001      | 81349        | . SOCKET . . . . .   | 16              |                | XB       |
| -3               | 645448-901        | 37695        | . MICROCIRCUIT, DIGITAL (ESDS) . . . . .                               | 5               |                | PADZZ    |
| -4               | 646199-1          | 37695        | . SEMICONDUCTOR DEVICE . . . . .                                       | 1               |                | PADZZ    |
|                  | =LL209R           | 05464        | . SEMICONDUCTOR DEVICE . . . . .                                       | 1               |                | PADZZ    |
|                  | *JANTX1N6092      | 81349        | . SEMICONDUCTOR DEVICE . . . . .                                       | 1               |                | PADZZ    |
| -5               | 348894-1          | 37695        | . SPACER, LEAD . . . . .   | 1               |                | XB       |
| -6               | RCR050512JS       | 81349        | . RESISTOR . . . . .   | 2               |                | PADZZ    |
| -7               | 616384-905        | 37695        | . SEMICONDUCTOR DEVICE . . . . .                                       | 1               |                | PADZZ    |
| -8               | RCR050105JS       | 81349        | . RESISTOR . . . . .   | 1               |                | PADZZ    |
| -9               | RNC50H6981FM      | 81349        | . RESISTOR . . . . .   | 1               |                | PADZZ    |
| -10              | RNC50H3322FR      | 81349        | . RESISTOR . . . . .   | 1               |                | PADZZ    |
| -11              | M39014/01-1593    | 81349        | . CAPACITOR . . . . .  | 6               |                | PADZZ    |
|                  | *M39014/01-1473   | 81349        | . CAPACITOR . . . . .  | 6               |                | PADZZ    |
| -12              | 186095-1          | 37695        | . CONNECTOR, STRIP . . . . .   | 9               |                | PADZZ    |
| -13              | 615506-901        | 37695        | . MICROCIRCUIT, LINEAR (ESDS) . . . . .                                | 1               |                | PADZZ    |
|                  | =M38510/11201BCB  | 81349        | . MICROCIRCUIT (ESDS) . . . . .  | 1               |                | PADZZ    |
|                  | *JM38510/11201BCX | 81349        | . MICROCIRCUIT (ESDS) . . . . .  | 1               |                | PADZZ    |
| -14              | 617713-902        | 37695        | . TRANSISTOR (ESDS) . . . . .  | 2               |                | PADZZ    |
| -15              | 7717-15N          | 13103        | . MOUNTING PAD (MAGNAVOX SPEC . . . . .<br>CONT DWG 447173-1)          | 2               |                | PADZZ    |
| -16              | JANTX1N5616       | 81349        | . SEMICONDUCTOR DEVICE . . . . .                                       | 2               |                | PADZZ    |
| -17              | RWR8151001BR      | 81349        | . RESISTOR . . . . .   | 2               |                | PADZZ    |
| -18              | RCR050104JS       | 81349        | . RESISTOR . . . . .   | 11              |                | PADZZ    |
| -19              | RNC50JS5492BS     | 81349        | . RESISTOR . . . . .   | 1               |                | PADZZ    |
| -20              | 615969-901        | 37695        | . MICROCIRCUIT, DIGITAL (ESDS) . . . . .                               | 3               |                | PADZZ    |
|                  | =JM38510/17001BCX | 81349        | . MICROCIRCUIT (ESDS) . . . . .  | 3               |                | PADZZ    |
| -21              | =RNC65J1021BS     | 81349        | . RESISTOR . . . . .   | 1               |                | PADZZ    |
|                  | =RNC65J1041BS     | 81349        | . RESISTOR . . . . .   | 1               |                | PADZZ    |
|                  | =RNC65J1051BS     | 81349        | . RESISTOR . . . . .   | 1               |                | PADZZ    |
|                  | =RNC65J1061BS     | 81349        | . RESISTOR . . . . .   | 1               |                | PADZZ    |
|                  | =RNC65J1071BS     | 81349        | . RESISTOR . . . . .   | 1               |                | PADZZ    |
|                  | =RNC65J1091BS     | 81349        | . RESISTOR . . . . .   | 1               |                | PADZZ    |
|                  | =RNC65J1101BS     | 81349        | . RESISTOR . . . . .   | 1               |                | PADZZ    |
|                  | =RNC65J1111BS     | 81349        | . RESISTOR . . . . .   | 1               |                | PADZZ    |
|                  | =RNC65J1131BS     | 81349        | . RESISTOR . . . . .   | 1               |                | PADZZ    |
|                  | =RNC65J1141BS     | 81349        | . RESISTOR . . . . .   | 1               |                | PADZZ    |
|                  | =RNC65J1151BS     | 81349        | . RESISTOR . . . . .   | 1               |                | PADZZ    |
|                  | =RNC65J1171BS     | 81349        | . RESISTOR . . . . .   | 1               |                | PADZZ    |
|                  | =RNC65J1181BS     | 81349        | . RESISTOR . . . . .   | 1               |                | PADZZ    |
| -22              | RCR050513JS       | 81349        | . RESISTOR . . . . .   | 3               |                | PADZZ    |
| -23              | 616504-901        | 37695        | . MICROCIRCUIT, DIGITAL (ESDS) . . . . .                               | 1               |                | PADZZ    |
|                  | =M38510/17203BCB  | 81349        | . MICROCIRCUIT (ESDS) . . . . .  | 1               |                | PADZZ    |
|                  | *JM38510/17203BCX | 81349        | . MICROCIRCUIT (ESDS) . . . . .  | 1               |                | PADZZ    |
| -24              | RCR200432JS       | 81349        | . RESISTOR . . . . .   | 1               |                | PADZZ    |
| -25              | M384010BK1003JC   | 81349        | . RESISTOR . . . . .   | 1               |                | PADZZ    |
| -26              | 616172-901        | 37695        | . MICROCIRCUIT, DIGITAL (ESDS) . . . . .                               | 3               |                | PADZZ    |
|                  | =JM38510/17505BEX | 81349        | . MICROCIRCUIT (ESDS) . . . . .  | 3               |                | PADZZ    |
| -27              | 646230-901        | 37695        | . MICROCIRCUIT, DIGITAL (ESDS) . . . . .                               | 1               |                | PADZZ    |
| -28              | M39014/01-1351    | 81349        | . CAPACITOR . . . . .  | 2               |                | PADZZ    |
|                  | *M39014/01-1271   | 81349        | . CAPACITOR . . . . .  | 2               |                | PADZZ    |
| -29              | M39003/03-0384    | 81349        | . CAPACITOR . . . . .  | 2               |                | PADZZ    |
|                  | *M39003/03-0184   | 81349        | . CAPACITOR . . . . .  | 2               |                | PADZZ    |
| -30              | M39003/03-0358    | 81349        | . CAPACITOR . . . . .  | 2               |                | PADZZ    |
|                  | *M39003/03-0258   | 81349        | . CAPACITOR . . . . .  | 2               |                | PADZZ    |
| -31              | 616492-901        | 37695        | . MICROCIRCUIT, DIGITAL (ESDS) . . . . .                               | 3               |                | PADZZ    |
|                  | =JM38510/05151BCX | 81349        | . MICROCIRCUIT (ESDS) . . . . .  | 3               |                | PADZZ    |
| -32              | 646232-901        | 37695        | . MICROCIRCUIT (ESDS) . . . . .  | 1               |                | PADZZ    |
| -33              | 186095-7          | 37695        | . CONNECTOR, STRIP . . . . .   | 1               |                | XB       |
| -34              | 645516-901        | 37695        | . MICROCIRCUIT (ESDS) . . . . .  | 2               |                | PADZZ    |
| -35              | 645514-901        | 37695        | . MICROCIRCUIT (ESDS) . . . . .  | 2               |                | PADZZ    |
| -36              | 616379-901        | 37695        | . MICROCIRCUIT, DIGITAL (ESDS) . . . . .                               | 1               |                | PADZZ    |
|                  | =JM38510/17305BEX | 81349        | . MICROCIRCUIT (ESDS) . . . . .  | 1               |                | PADZZ    |
| -37              | CD4016BMJ/883B    | 27014        | . MICROCIRCUIT (ESDS) (MAGNAVOX . . . . .<br>SPEC CONT DWG 645513-901) | 3               |                | PADZZ    |
| -38              | M39014/02-1407    | 81349        | . CAPACITOR . . . . .  | 3               |                | PADZZ    |
|                  | *M39014/02-1407   | 81349        | . CAPACITOR . . . . .  | 3               |                | PADZZ    |

| FIG. &<br>INDEX<br>NO. | PART NUMBER       | FSCM  | 1234567 | DESCRIPTION  | UNITS<br>PER<br>ASSY. | USABLE<br>ON<br>CODE | SMR<br>CODE |
|------------------------|-------------------|-------|---------|--|-----------------------|----------------------|-------------|
| 7-20-39                | 87362-3           | 00779 |         | CONNECTOR, RECEPTACLE (MAGNAVOX. . .<br>SPEC CONT DWG 185626-9)      | 2                     |                      | PADZZ       |
| -40                    | 5210-128-11       | 00779 |         | CONNECTOR, RECEPTACLE (MAGNAVOX. . .<br>SPEC CONT DWG 185928-106)    | 1                     |                      | PADZZ       |
| -41                    | 616492-901        | 37695 |         | MICROCIRCUIT, DIGITAL (ESDS) . . . . .                               | 2                     |                      | PADZZ       |
|                        | =JM38510/05051BCX | 81349 |         | MICROCIRCUIT (ESDS) . . . . .  | 2                     |                      | PADZZ       |
| -42                    | 7702501EX         | 14933 |         | MICROCIRCUIT (MAGNAVOX SPEC . . . . .<br>CONT DWG 616175-901) (ESDS) | 1                     |                      | PADZZ       |
| -43                    | 615747-901        | 37695 |         | MICROCIRCUIT (ESDS) . . . . .  | 2                     |                      | PADZZ       |
| -44                    | PE2-65            | 98978 |         | HEAT SINK/IC'S (MAGNAVOX SPEC . . . . .<br>CONT DWG 435688-2)        | 2                     |                      | XB          |
| -45                    | 435690-1          | 37695 |         | RETAINER, HEAT SINK. . . . .   | 2                     |                      | XB          |
| -46                    | MS51957-4         | 96906 |         | SCREW (AP) . . . . .   | 4                     |                      | PAFZZ       |
|                        | MS35338-134       | 96906 |         | WASHER (AP) . . . . .  | 4                     |                      | PAFZZ       |
|                        | NAS620C2          | 80205 |         | WASHER (AP) . . . . .  | 4                     |                      | PAFZZ       |
|                        | NAS671C2          | 80205 |         | NUT (AP) . . . . .   | 4                     |                      | PAFZZ       |
| -47                    | RCR050103JB       | 81349 |         | RESISTOR. . . . .  | 2                     |                      | PADZZ       |
| -48                    | JANTX1N4454-1     | 81349 |         | SEMICONDUCTOR DEVICE. . . . .  | 1                     |                      | PADZZ       |
| -49                    | RWRB186190FR      | 81349 |         | RESISTOR. . . . .  | 1                     |                      | PADZZ       |
| -50                    | MS75085-19        | 96906 |         | COIL, RADIO FREQUENCY. . . . .                                       | 1                     |                      | PADZZ       |
| -51                    | 275056-3242       | 37695 |         | CAPACITOR . . . . .  | 2                     |                      | PADZZ       |
| -52                    | 616521-901        | 37695 |         | MICROCIRCUIT, DIGITAL (ESDS) . . . . .                               | 1                     |                      | PADZZ       |
|                        | =JM38510/05754BEX | 81349 |         | MICROCIRCUIT (ESDS) . . . . .  | 1                     |                      | PADZZ       |
| -53                    | 619998-2          | 37695 |         | MICROCIRCUIT, DIGITAL (ESDS) . . . . .                               | 1                     |                      | PADZZ       |
|                        | =CD4508BD/3       | 02735 |         | MICROCIRCUIT, DIGITAL (ESDS) . . . . .                               | 1                     |                      | PADZZ       |
|                        | *JM38510/17602BJX | 81349 |         | MICROCIRCUIT (ESDS) . . . . .  | 1                     |                      | PADZZ       |
| -54                    | 645503-901        | 37695 |         | MICROCIRCUIT, DIGITAL (ESDS) . . . . .                               | 1                     |                      | PADZZ       |
|                        | =M38510/17301BJB  | 81349 |         | MICROCIRCUIT (ESDS) . . . . .  | 1                     |                      | PADZZ       |
|                        | *JM38510/17301BJX | 81349 |         | MICROCIRCUIT (ESDS) . . . . .  | 1                     |                      | PADZZ       |
| -55                    | 186095-5          | 37695 |         | CONNECTOR, STRIP . . . . .   | 1                     |                      | XB          |
| -56                    | 7705801EX         | 14933 |         | MICROCIRCUIT (MAGNAVOX SPEC . . . . .<br>CONT DWG 615745-901) (ESDS) | 1                     |                      | PADZZ       |
| -57                    | 616506-901        | 37695 |         | MICROCIRCUIT, DIGITAL (ESDS) . . . . .                               | 1                     |                      | PADZZ       |
|                        | =JM38510/05553BEX | 81349 |         | MICROCIRCUIT (ESDS) . . . . .  | 1                     |                      | PADZZ       |
| -58                    | 7917010X          | 14933 |         | MICROCIRCUIT (MAGNAVOX SPEC . . . . .<br>CONT DWG 645515-901) (ESDS) | 1                     |                      | PADZZ       |
| -59                    | 619905-901        | 37695 |         | INTEGRATED CIRCUIT. . . . .  | 2                     |                      | PADZZ       |
| -60                    | 616521-902        | 37695 |         | MICROCIRCUIT, DIGITAL (ESDS) . . . . .                               | 1                     |                      | PADZZ       |
|                        | =JM38510/05753BEX | 81349 |         | MICROCIRCUIT (ESDS) . . . . .  | 1                     |                      | PADZZ       |
| -61                    | 186095-8          | 37695 |         | CONNECTOR, STRIP . . . . .   | 1                     |                      | XB          |
| -62                    | 616492-903        | 37695 |         | MICROCIRCUIT (ESDS) . . . . .  | 1                     |                      | PADZZ       |
| -63                    | 646229-901        | 37695 |         | MICROCIRCUIT (ESDS) . . . . .  | 1                     |                      | PADZZ       |
| -64                    | 5188-466-8        | 00779 |         | CONNECTOR, RECEPTACLE (MAGNAVOX. . . . .<br>SPEC CONT DWG 186374-1)  | 1                     |                      | PADZZ       |
| -65                    | 626482-2          | 37695 |         | DISPLAY, OPTO-ELECTRIC . . . . .                                     | 1                     |                      | PADZZ       |
| -66                    | 626482-1          | 37695 |         | DISPLAY, OPTO-ELECTRIC . . . . .                                     | 2                     |                      | PADZZ       |
| -67                    | 626482-3          | 37695 |         | DISPLAY, OPTO-ELECTRIC . . . . .                                     | 1                     |                      | PADZZ       |
| -68                    | MS51957-30        | 96906 |         | SCREW . . . . .  | 5                     |                      | PAFZZ       |
|                        | MS35338-136       | 96906 |         | WASHER. . . . .  | 5                     |                      | PAFZZ       |
|                        | NAS620C6          | 80205 |         | WASHER. . . . .  | 5                     |                      | PAFZZ       |
| -69                    | 348240-1          | 37695 |         | HOLDER, ELASTOMERIC. . . . .   | 4                     |                      | XB          |
| -70                    | 514825-1          | 37695 |         | BEZEL, MOUNTING. . . . .   | 1                     |                      | XB          |
| -71                    | 186163-3          | 37695 |         | CONNECTOR, LAYERED ELASTOMERIC . . . . .                             | 16                    |                      | XB          |
| -72                    | 813676-801        | 37695 |         | HEATING, ELEMENT . . . . .   | 4                     |                      | PADZZ       |
| -73                    | 625488-1          | 37695 |         | PANEL, ELECTROLUMINESCENT. . . . .                                   | 4                     |                      | XB          |
| -74                    | 186163-5          | 37695 |         | CONNECTOR, LAYERED ELASTOMERIC . . . . .                             | 4                     |                      | XB          |
| -75                    | 412045-1          | 37695 |         | PRINTED WIRING BOARD. . . . .  | 1                     |                      | XB          |

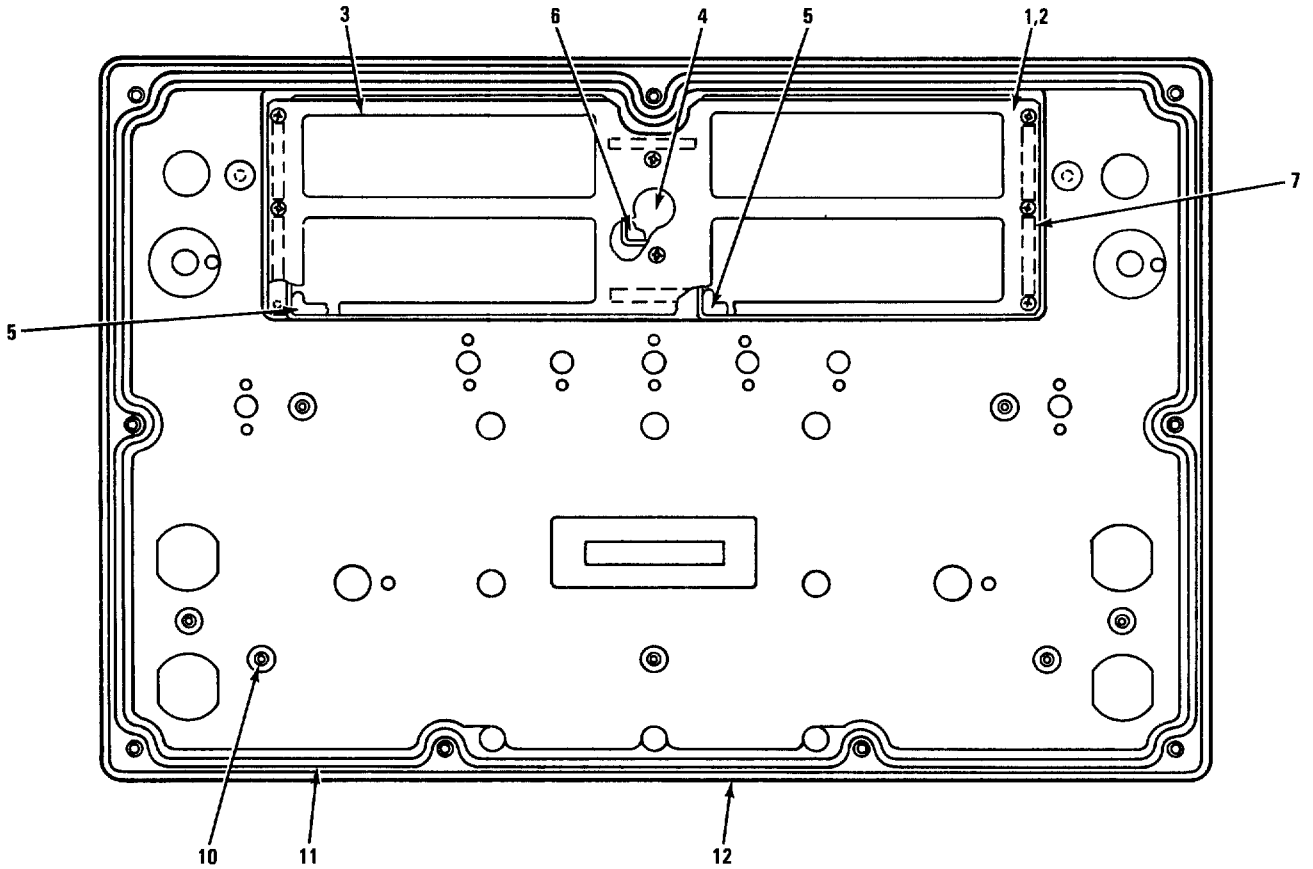
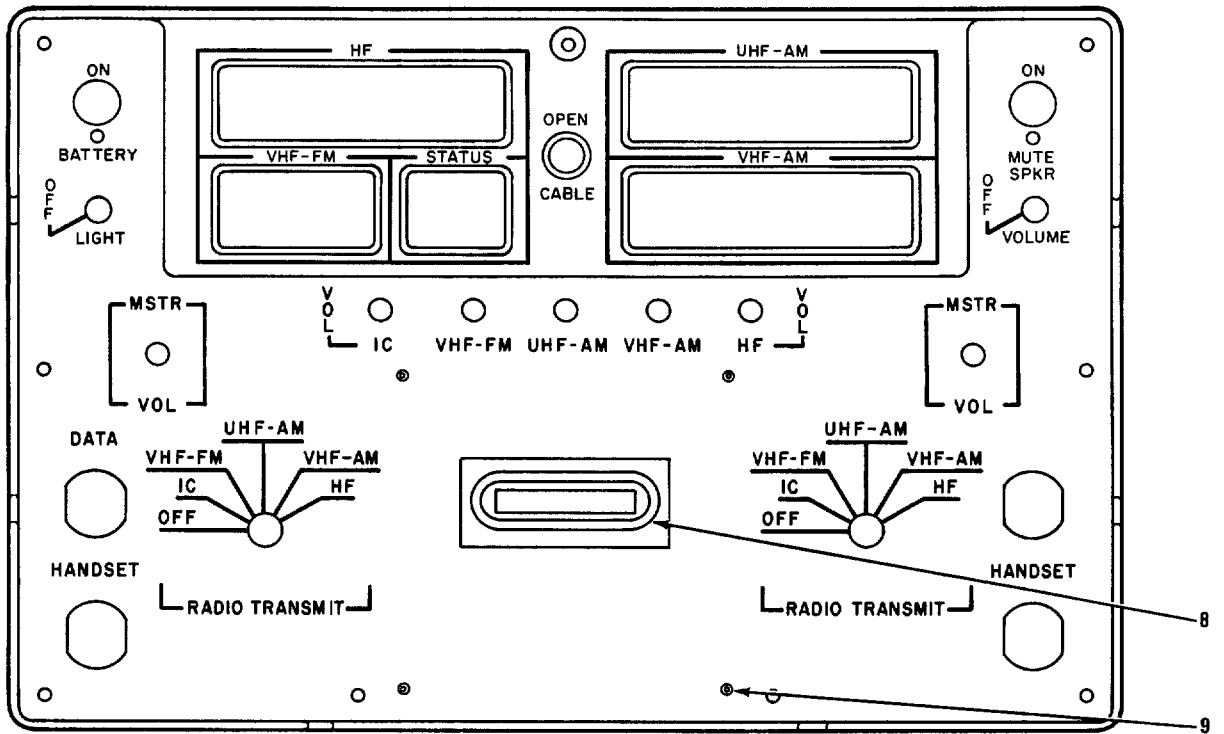

MX-61-119-IPB-21  
 REF MAG DWG 660155 REV J  
 PL 660155 REV G

FIGURE 7-21. RADIO SET CONTROL PANEL

| FIG. &<br>INDEX<br>NO. | PART NUMBER | FSCM  | 1234567 | DESCRIPTION  | UNITS<br>PER<br>ASSY. | USABLE<br>ON<br>CODE | SMR<br>CODE |
|------------------------|-------------|-------|---------|--|-----------------------|----------------------|-------------|
| 7-21-                  | 660155-801  | 37695 |         | PANEL, RADIO SET CONTROL. . . . .<br>(SEE FIGURE 7-18 FOR NHA) | REF                   |                      | XB          |
| -1                     | 938669-1    | 37695 |         | PLATE, RETAINING, WINDOW. . . . .                              | 1                     |                      | XB          |
| -2                     | MS51959-2   | 96906 |         | SCREW (AP). . . . .  | 8                     |                      | PAFZZ       |
| -3                     | 348253-1    | 37695 |         | WINDOW, OBSERVATION. . . . .                                   | 2                     |                      | PADZZ       |
| -4                     | 348253-2    | 37695 |         | WINDOW, OBSERVATION. . . . .                                   | 1                     |                      | PADZZ       |
| -5                     | 349217-1    | 37695 |         | GASKET, URSC WINDOW. . . . .                                   | 2                     |                      | PADZZ       |
| -6                     | 349217-2    | 37695 |         | GASKET, URSC WINDOW. . . . .                                   | 1                     |                      | PADZZ       |
| -7                     | 349217-3    | 37695 |         | GASKET, URSC WINDOW. . . . .                                   | 6                     |                      | PADZZ       |
| -8                     | 348403-3    | 37695 |         | GASKET, RUBBER . . . . .                                       | 1                     |                      | PAFZZ       |
| -9                     | MS122116    | 96906 |         | INSERT. . . . .  | 4                     |                      | PAFZZ       |
| -10                    | MS122118    | 96906 |         | INSERT. . . . .  | 7                     |                      | PAFZZ       |
| -11                    | 348294-2    | 37695 |         | GASKET, SEAL . . . . .   | 1                     |                      | PAFZZ       |
| -12                    | 660155-1    | 37695 |         | PANEL, URSC. . . . .   | 1                     |                      | XA          |

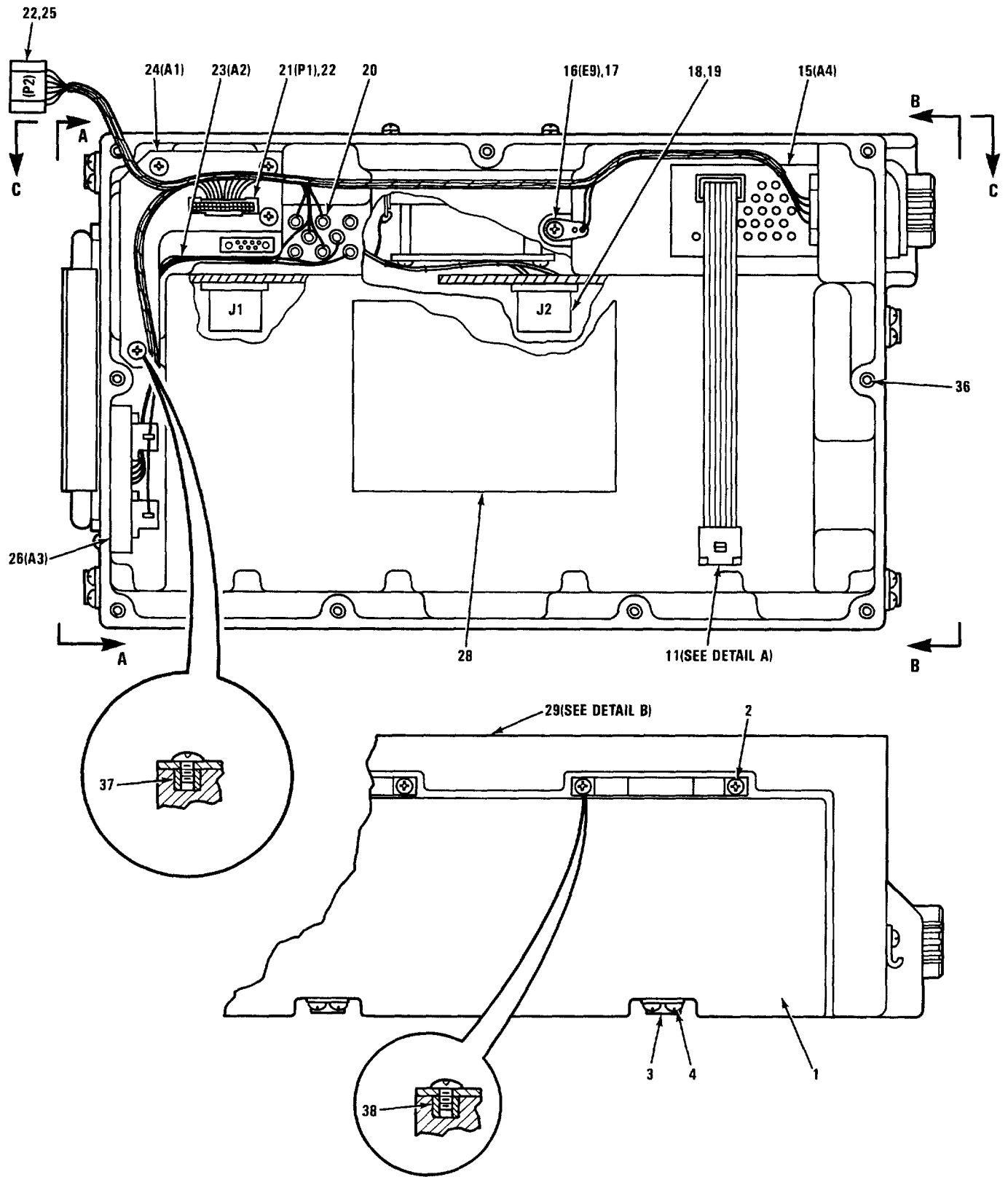

NOTE: REFERENCE DESIGNATIONS ARE ABBREVIATED.  
 PREFIX WITH 5A1 OR 6A1.

MX-61-119-IPB-22-1  
 REF MAG DWG 812092 REV J  
 PL 812092 REV AH

FIGURE 7-22. CASE ASSEMBLY (SHEET 1 OF 4)

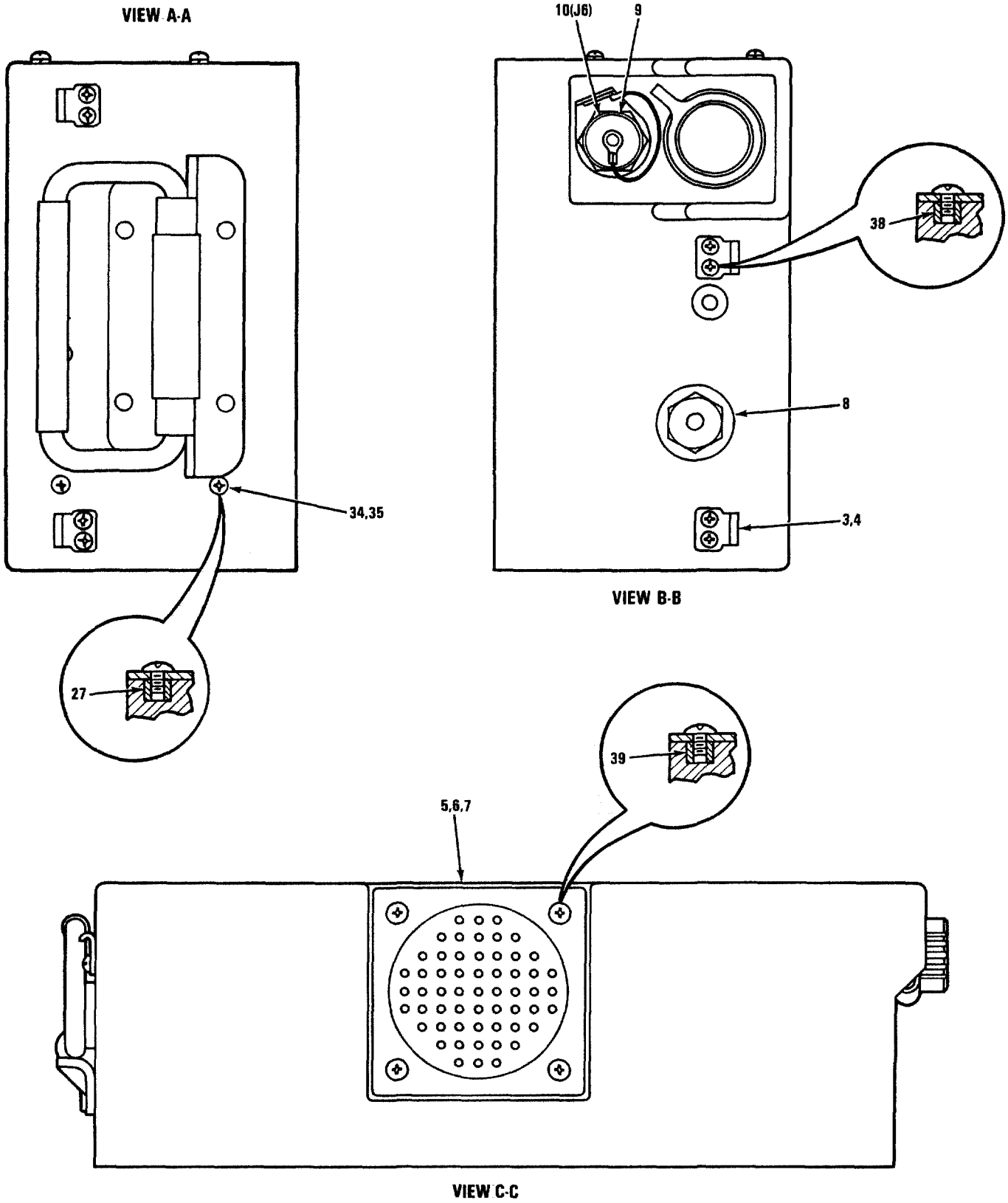

NOTE: REFERENCE DESIGNATIONS ARE ABBREVIATED.  
PREFIX WITH 5A1 OR 6A1.

MX-61-119-IPB-22-2

FIGURE 7-22. CASE ASSEMBLY (SHEET 2 OF 4)

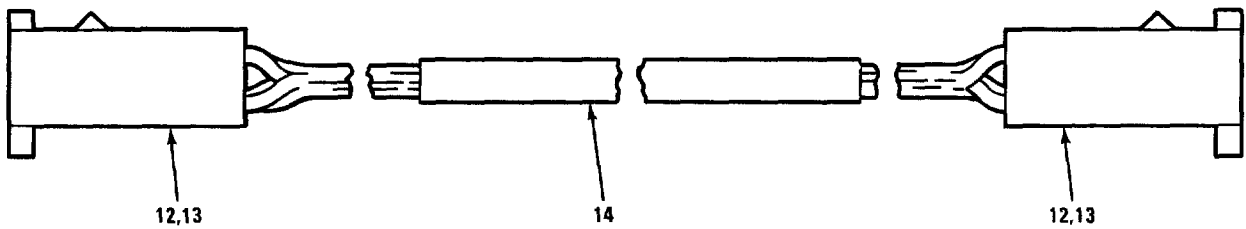
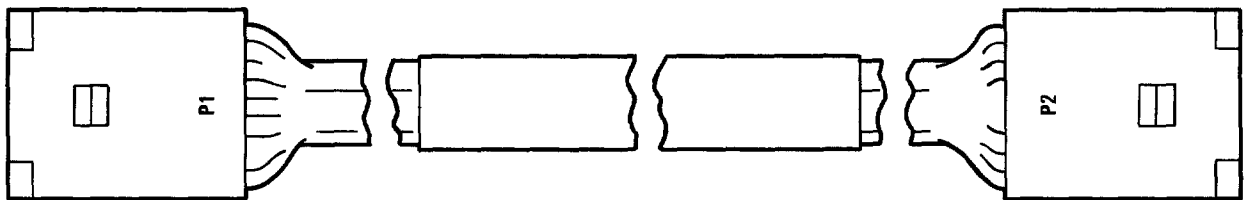

DETAIL A

NOTE: REFERENCE DESIGNATIONS ARE ABBREVIATED.  
PREFIX WITH 5A1 OR 6A1.

MX-61-119-IPB-22-3

FIGURE 7-22. CASE ASSEMBLY (SHEET 3 OF 4)

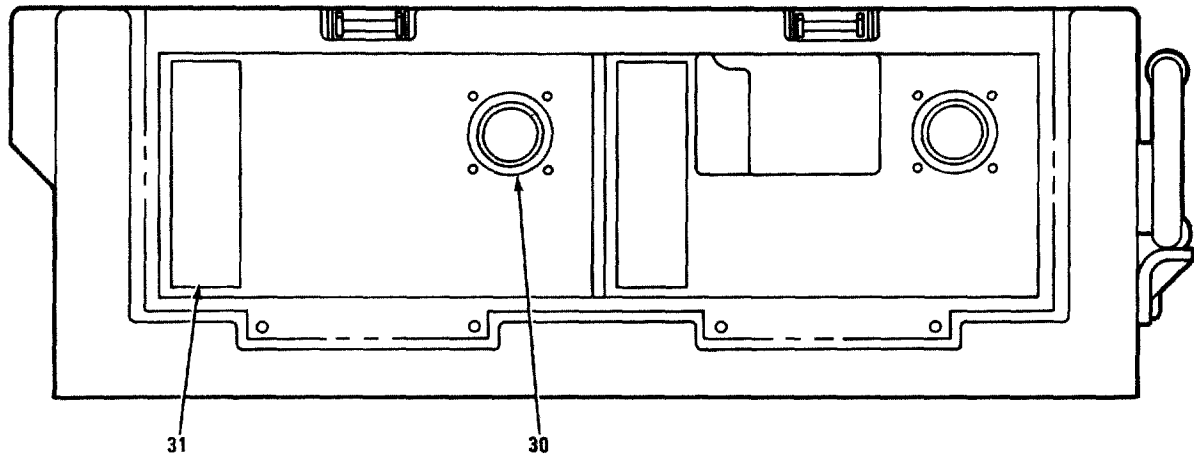
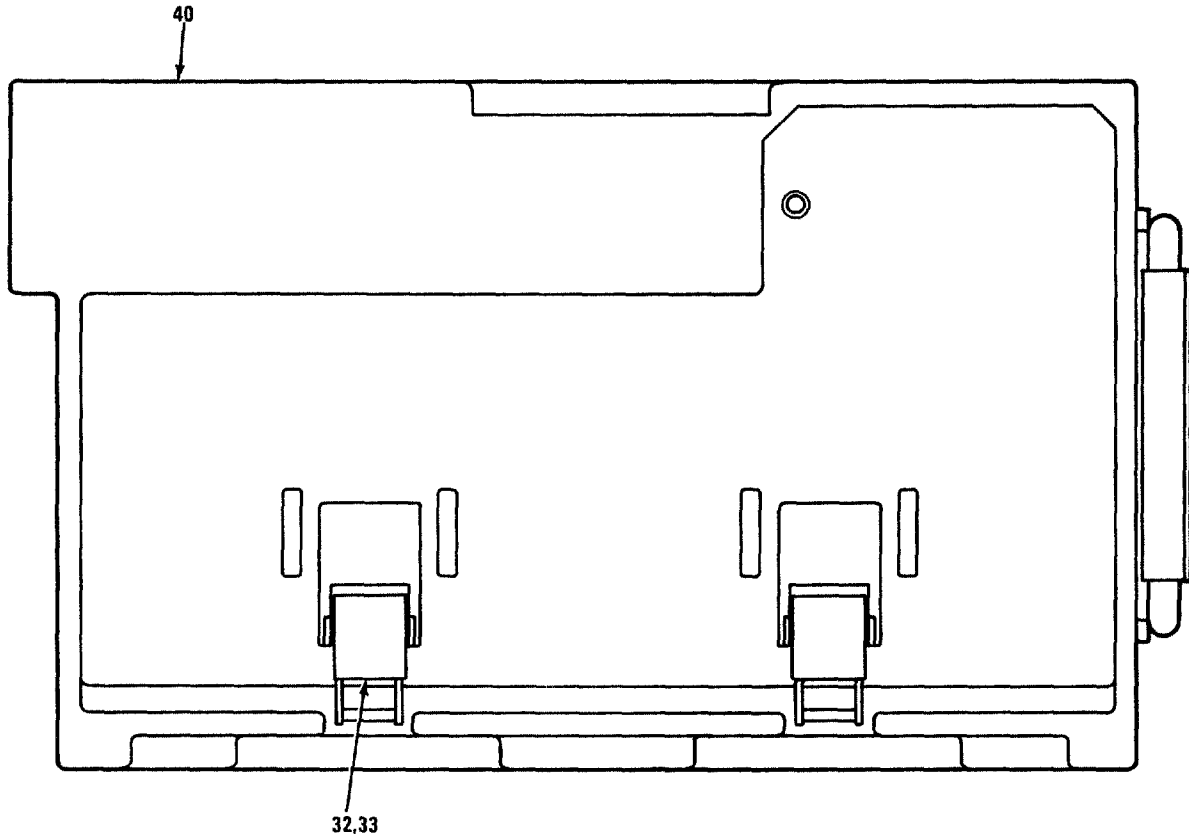

DETAIL B

NOTE: REFERENCE DESIGNATIONS ARE ABBREVIATED.  
PREFIX WITH 5A1 OR 6A1.

MX-61-119-IPB-22-4

FIGURE 7-22. CASE ASSEMBLY (SHEET 4 OF 4)



| FIGURE AND<br>INDEX<br>NUMBER | PART<br>NUMBER                 | FSCM  | DESCRIPTION   | UNITS       | USE        | SMR<br>CODE |
|-------------------------------|--------------------------------|-------|---|-------------|------------|-------------|
|                               |                                |       |   | PER<br>ASSY | ON<br>CODE |             |
| 7-22-                         | 812092-801                     | 37695 | CASE ASSEMBLY (SEE FIGURE 7-17 FOR NHA).....                        | REF         |            | XB          |
| -1                            | 514900-801                     | 37695 | . DOOR ASSEMBLY .....   | 1           |            | XB          |
| -2                            | MS51957-28B                    | 96906 | . SCREW (AP).....   | 4           |            | PAFZZ       |
| -3                            | SC-B-83314-2CE-<br>O.D.-STRIKE | 98033 | . LATCH ASSEMBLY (MAGNAVOX SPEC CONT.....<br>DWG 125249-1)          | 6           |            | PAFZZ       |
| -4                            | MS51957-13B                    | 96906 | . SCREW (AP).....   | 2           |            | PAFZZ       |
|                               | MS51957-27B                    | 96906 | . SCREW (AP).....   | 2           |            | PAFZZ       |
|                               | MS35338-135                    | 96906 | . WASHER (AP).....  | 2           |            | PAFZZ       |
| -5                            | H-301-6                        | 60073 | . LOUDSPEAKER, 3-INCH (MAGNAVOX SPEC.....<br>CONT DWG 588258-2)     | 1           |            | PAFZZ       |
| -6                            | MS51957-46B                    | 96906 | . SCREW (AP).....   | 4           |            | PAFZZ       |
|                               | 349850-1                       | 37695 | . WASHER (AP).....  | 4           |            | PAFZZ       |
| -7                            | 349153-1                       | 37695 | . GASKET.....   | 1           |            | PADZZ       |
| -8                            | 722385-801                     | 37695 | . VALVE, BREATHER (MAGNAVOX SPEC CONT.....<br>DWG 435683-1)         | 1           |            | XB          |
| -9                            | 186749-1                       | 37695 | . COVER, ELECTRIC .....   | 1           |            | PAFZZ       |
| -10                           | M83114E10-6P                   | 96906 | . CONNECTOR.....  | 1           |            | PADZZ       |
| -11                           | 566613-801                     | 37695 | . CABLE ASSEMBLY .....  | 1           |            | XB          |
| -12                           | 87631-6                        | 00779 | . . CONNECTOR, RECEPTACLE (MAGNAVOX.....<br>SPEC CONT DWG 185971-3) | 2           |            | PADZZ       |
| -13                           | 87046-3                        | 00779 | . . CONTACT, ELECTRICAL (MAGNAVOX SPEC.....<br>CONT DWG 165338-5)   | 20          |            | PADZZ       |
| -14                           | 155931-9                       | 37695 | . . STRAP, TIEDOWN .....  | 1           |            | XA          |
| -15                           | 812099-801                     | 37695 | . FIBER OPTIC MODULE ASSEMBLY (SEE.....<br>FIGURE 7-11 FOR BKDN)    | 1           |            | PADLD       |
| -16                           | MS77068-2                      | 96906 | . TERMINAL, LUG .....   | 1           |            | XB          |
| -17                           | MS51957-26                     | 96906 | . SCREW (AP).....   | 1           |            | PAFZZ       |
| -18                           | =CA110821-10                   | 08718 | . CONNECTOR, RECEPTACLE (MAGNAVOX.....<br>SPEC CONT DWG 186161-1)   | 2           |            | PADZZ       |
|                               | =186161-2                      | 37695 | . CONNECTOR, RECEPTACLE .....                                       | 2           |            | PADZZ       |
| -19                           | MS51957-13                     | 96906 | . SCREW (AP).....   | 4           |            | PADZZ       |
| -20                           | FT-940-DUTR                    | 98291 | . TERMINAL, FEEDTHRU (MAGNAVOX SPEC.....<br>CONT DWG 205009-17)     | 8           |            | XB          |
| -21                           | 2-87631-2                      | 00779 | . CONNECTOR, RECEPTACLE (MAGNAVOX.....<br>SPEC CONT DWG 185971-6)   | 1           |            | PADZZ       |
| -22                           | 87046-3                        | 00779 | . CONTACT, ELECTRICAL (MAGNAVOX SPEC.....<br>CONT DWG 165338-5)     | 40          |            | PADZZ       |
| -23                           | 812933-801                     | 37695 | . BACK LIGHTING DRIVE .....   | 1           |            | PAFZZ       |
| -24                           | 812866-801                     | 37695 | . CIRCUIT CARD ASSEMBLY (SEE FIGURE 7-23.....<br>FOR BKDN)          | 1           |            | PAFLD       |
| -25                           | 1-87631-1                      | 00779 | . CONNECTOR.....  | 1           |            | PADZZ       |
| -26                           | 813286-801                     | 37695 | . VOLTAGE REGULATOR .....   | 1           |            | PADZZ       |
| -27                           | M83213-4                       | 96906 | . SCREW (AP).....   | 3           |            | PAFZZ       |
| -28                           | 348297-10                      | 37695 | . PAD, RUBBER .....   | 1           |            | XB          |
| -29                           | 660154-801                     | 37695 | . CASE, UNIFIED RADIO.....  | 1           |            | XA          |
| -30                           | M83461/1-116                   | 81349 | . . PACKING .....   | 2           |            | XB          |
| -31                           | 348297-2                       | 37695 | . . PAD, RUBBER.....  | 2           |            | XB          |
| -32                           | 128333-1                       | 37695 | . . CATCH, MODIFIED .....   | 2           |            | XB          |
| -33                           | MS20470AD4-6                   | 96906 | . . RIVET (AP) .....  | 2           |            | PADZZ       |
| -34                           | 128324-1                       | 37695 | . . HANDLE, BAIL .....  | 1           |            | XB          |
| -35                           | MS20470A6-8                    | 96906 | . . RIVET (AP) .....  | 4           |            | PADZZ       |
| -36                           | MS122119                       | 96906 | . . INSERT .....  | 9           |            | PADZZ       |
| -37                           | MS122118                       | 96906 | . . INSERT .....  | 4           |            | PADZZ       |
| -38                           | MS21209C0615L                  | 96906 | . . INSERT .....  | 12          |            | PADZZ       |
| -39                           | MS21209C0815L                  | 96906 | . . INSERT .....  | 4           |            | PADZZ       |
| -40                           | 660154-1                       | 37695 | . . CASE, UNIFIED RADIO .....                                       | 1           |            | XA          |

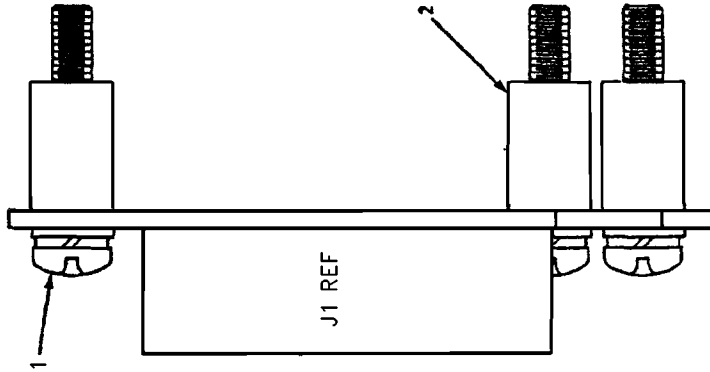

MX-61-119-IPB-23  
 REF MAG DWG 812866 REV E  
 PL 812866 REV N

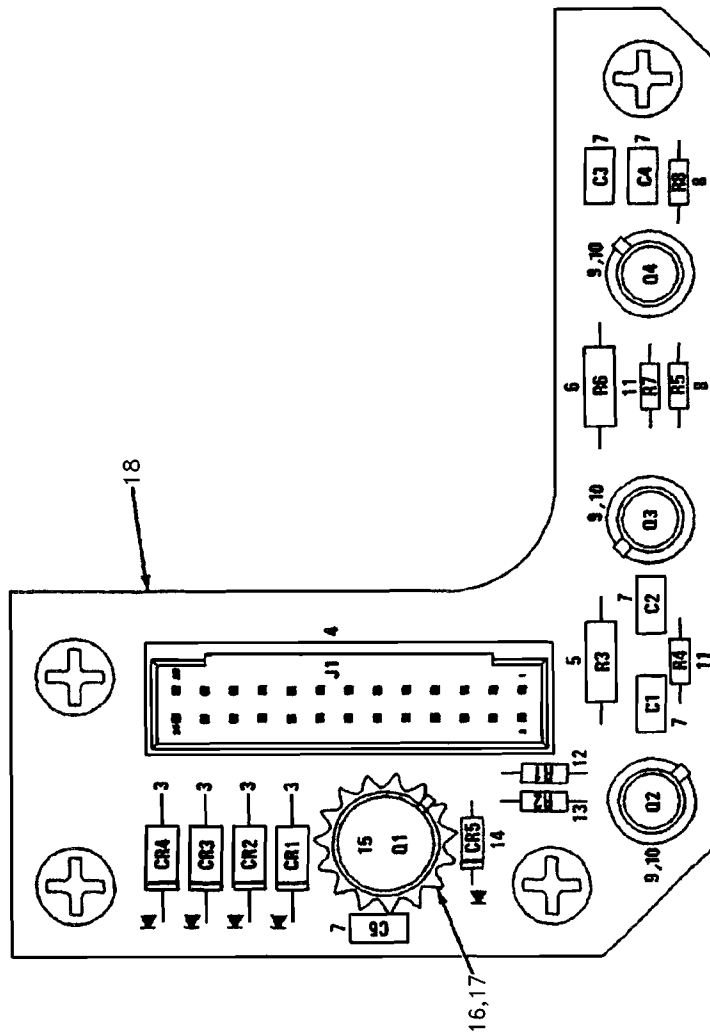

NOTE: REFERENCE DESIGNATIONS ARE ABBREVIATED.  
 PREFIX WITH 5A1A1 OR 6A1A1.

L0204152

Figure 7-23. Circuit Card Assembly

| FIG. &<br>INDEX<br>NO. | PART NUMBER     | FSCM  | 1234567 | DESCRIPTION  | UNITS<br>PER<br>ASSY. | USABLE<br>ON<br>CODE | SMR<br>CODE |
|------------------------|-----------------|-------|---------|--|-----------------------|----------------------|-------------|
| 7-23-                  | 812866-801      | 37695 |         | CIRCUIT CARD ASSEMBLY (SEE . . . . . REF<br>FIGURE 7-22 FOR NHA) |                       |                      | PAFLD       |
| -1                     | 136597-3        | 37695 |         | SCREW, MODIFIED. . . . .   | 4                     |                      | XB          |
|                        | M835338-136     | 96906 |         | WASHER. . . . .  | 4                     |                      | PAFZZ       |
|                        | NAB620C6        | 80205 |         | WASHER. . . . .  | 4                     |                      | PAFZZ       |
| -2                     | 136602-4        | 37695 |         | NUT, SLEEVE. . . . .   | 4                     |                      | XB          |
| -3                     | JANTX1N5616     | 81349 |         | SEMICONDUCTOR DEVICE. . . . .                                    | 4                     |                      | PADZZ       |
| -4                     | 5188-157-11     | 00779 |         | CONNECTOR, RECEPTACLE (MAGNAVOX.<br>SPEC CONT DWG 185972-9)      | 1                     |                      | PADZZ       |
| -5                     | RWR81S1R69FS    | 81349 |         | RESISTOR. . . . .  | 1                     |                      | PADZZ       |
|                        | *RWR81S1R69FR   | 81349 |         | RESISTOR. . . . .  | 1                     |                      | PADZZ       |
| -6                     | RWR81S1R27FR    | 81349 |         | RESISTOR. . . . .  | 1                     |                      | PADZZ       |
| -7                     | M39014/01-1593  | 81349 |         | CAPACITOR . . . . .  | 5                     |                      | PADZZ       |
|                        | *M39014/01-1473 | 81349 |         | CAPACITOR . . . . .  | 5                     |                      | PADZZ       |
| -8                     | RCRO5Q472J5     | 81349 |         | RESISTOR. . . . .  | 2                     |                      | PADZZ       |
| -9                     | JANTX2N2907A    | 81349 |         | SEMICONDUCTOR DEVICE. . . . .                                    | 3                     |                      | PADZZ       |
| -10                    | 10398-N         | 07047 |         | INSULATOR, TRANSISTOR (MAGNAVOX.<br>SPEC CONT DWG 447419-9)      | 3                     |                      | XB          |
| -11                    | RCRO5Q101J5     | 81349 |         | RESISTOR. . . . .  | 2                     |                      | PADZZ       |
| -12                    | RCRO5Q103J5     | 81349 |         | RESISTOR. . . . .  | 1                     |                      | PADZZ       |
| -13                    | RCRO5Q682J5     | 81349 |         | RESISTOR. . . . .  | 1                     |                      | PADZZ       |
| -14                    | JANTX1N4454-1   | 81349 |         | SEMICONDUCTOR DEVICE. . . . .                                    | 1                     |                      | PADZZ       |
| -15                    | JANTX2N3467     | 81349 |         | SEMICONDUCTOR DEVICE. . . . .                                    | 1                     |                      | PADZZ       |
| -16                    | 2257R           | 13103 |         | HEAT SINK (MAGNAVOX SPEC CONT<br>DWG 435619-1)                   | 1                     |                      | XB          |
| -17                    | M38527/5-02D    | 81349 |         | MOUNTING PAD. . . . .  | 1                     |                      | XB          |
| -18                    | 412274-1        | 37695 |         | PRINTED WIRING BOARD. . . . .                                    | 1                     |                      | XB          |

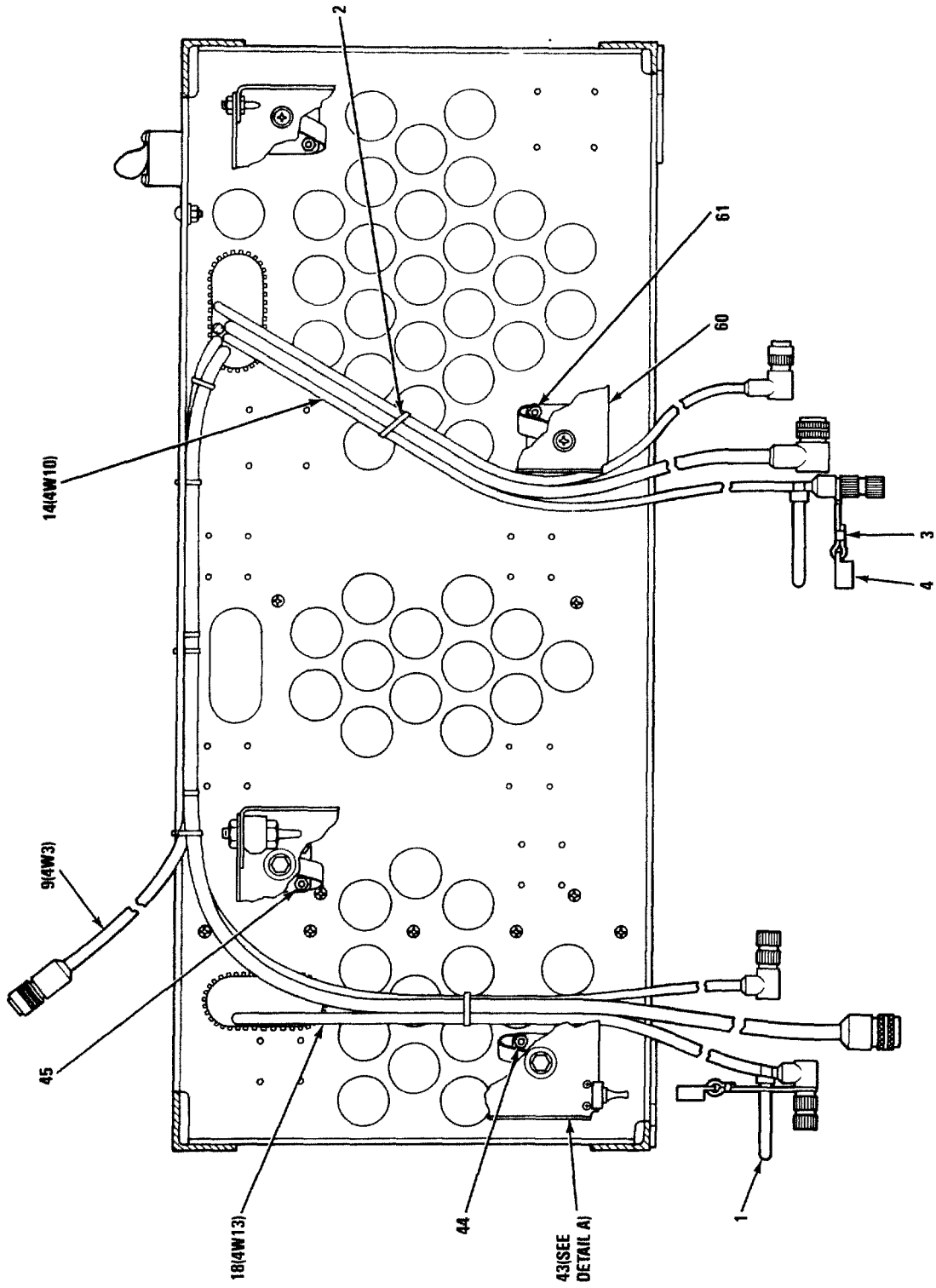

MX-61-119-IPB-24-1  
REF MAG DWG 812084 REV H  
PL 812084 REV Y

VIEW C-C

FIGURE 7-24. ELECTRICAL MOUNTING BASE, MT-6250/GRC-206 (SHEET 1 OF 12)

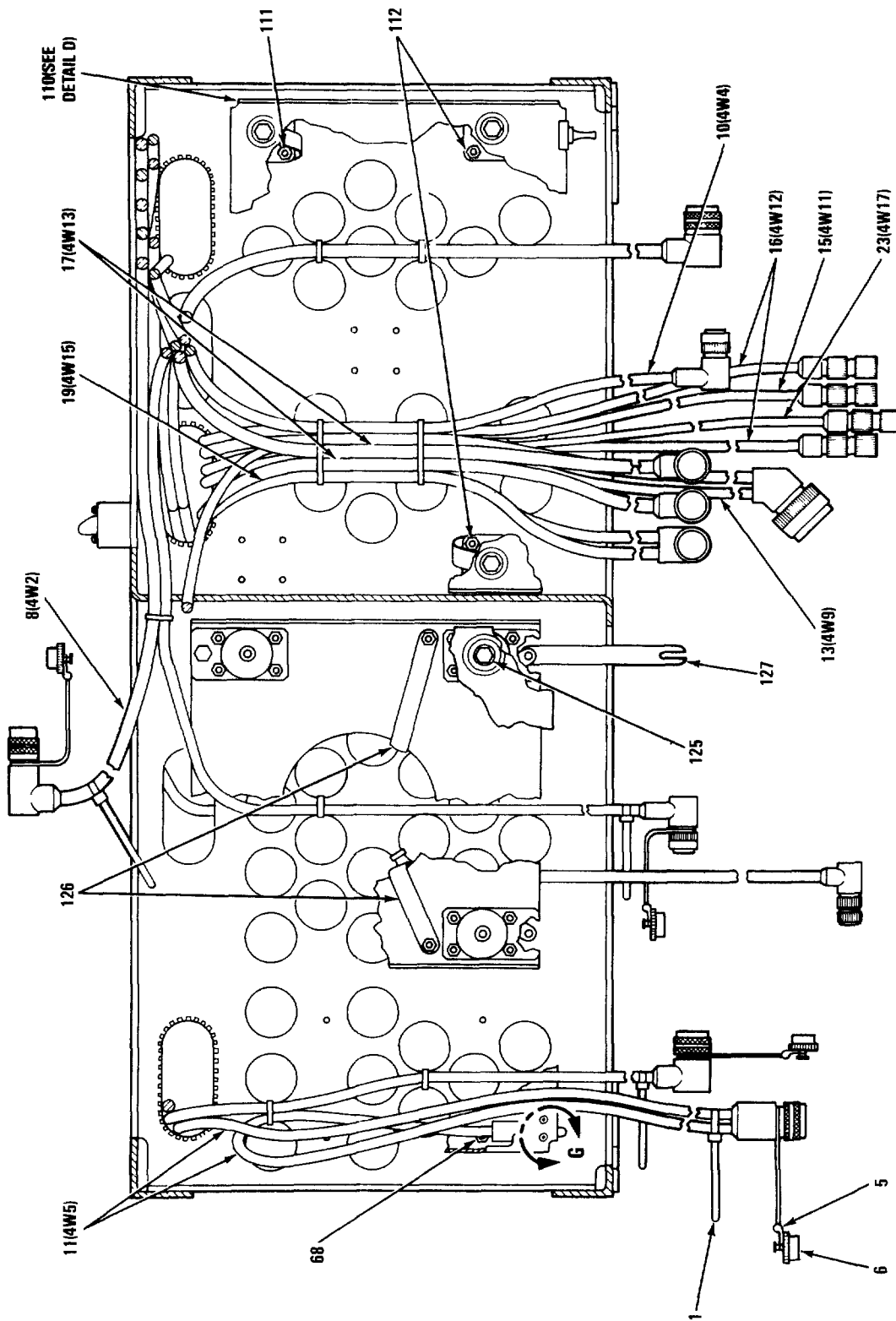

MX-61-119-IPB-24-2

VIEW D-D

FIGURE 7-24. ELECTRICAL MOUNTING BASE, MT-6250/GRC-206 (SHEET 2 OF 12)

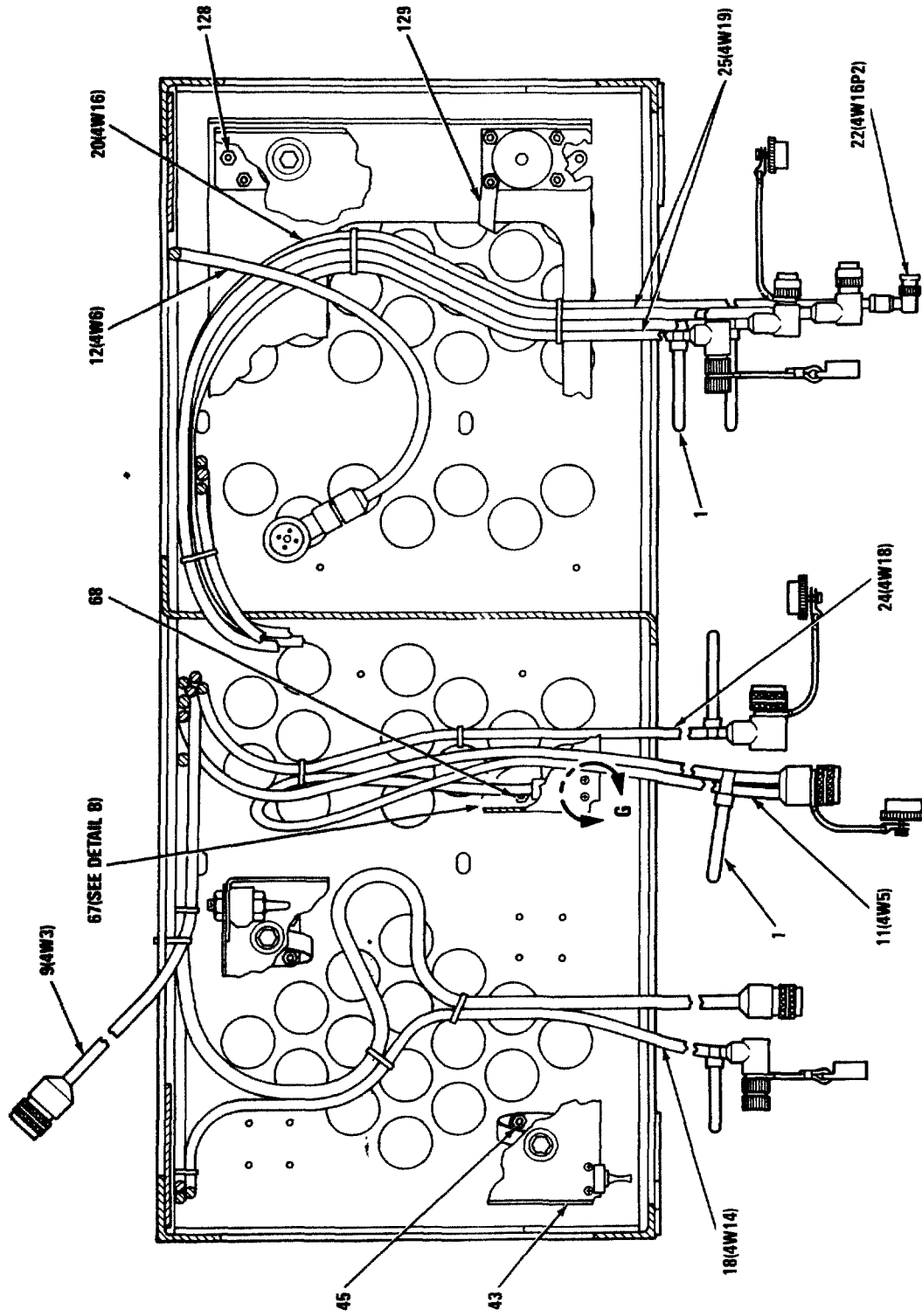

MX-61-119-PPB-24-3

VIEW E-E

FIGURE 7-24. ELECTRICAL MOUNTING BASE. MT-6250/GRC-206 (SHEET 3 OF 12)

MX-61-119-IPB-24-4

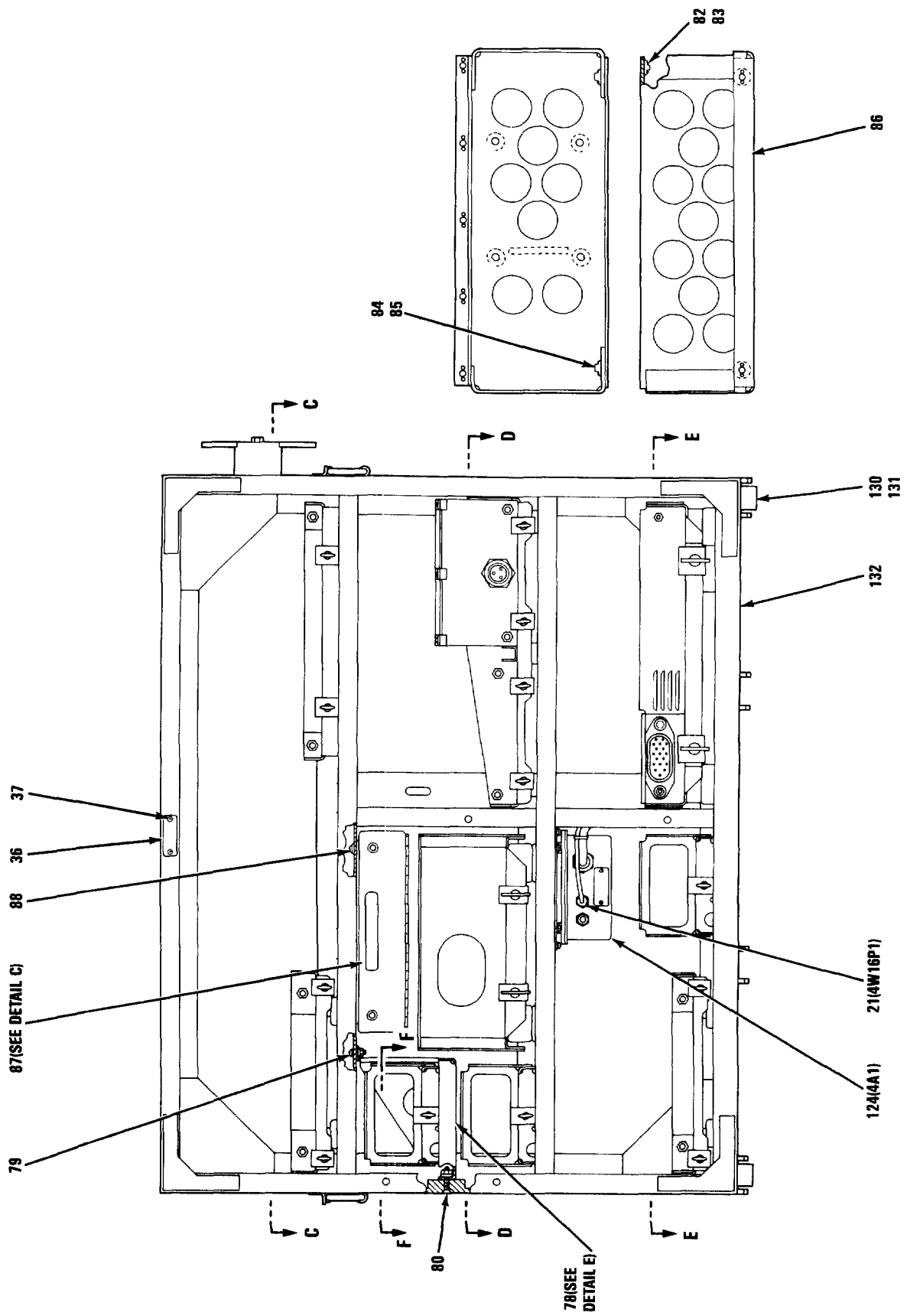
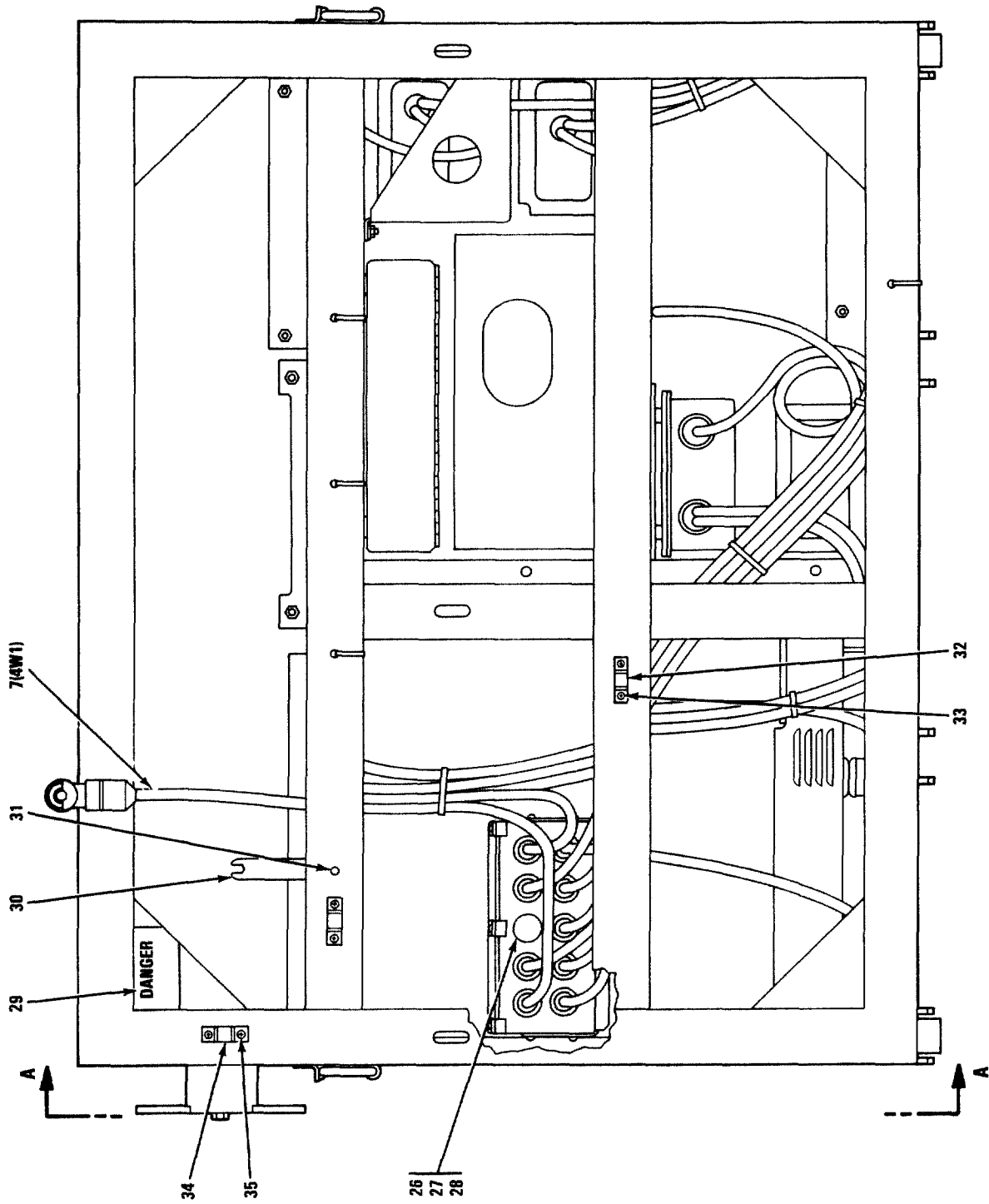

FIGURE 7-24. ELECTRICAL MOUNTING BASE, MT-6250/GRC-206 (SHEET 4 OF 12)



MX-61-119-IP8-24-5

REAR VIEW

FIGURE 7-24. ELECTRICAL MOUNTING BASE, MT-6250/GRC-206 (SHEET 5 OF 12)



MX-61-119, PB-245

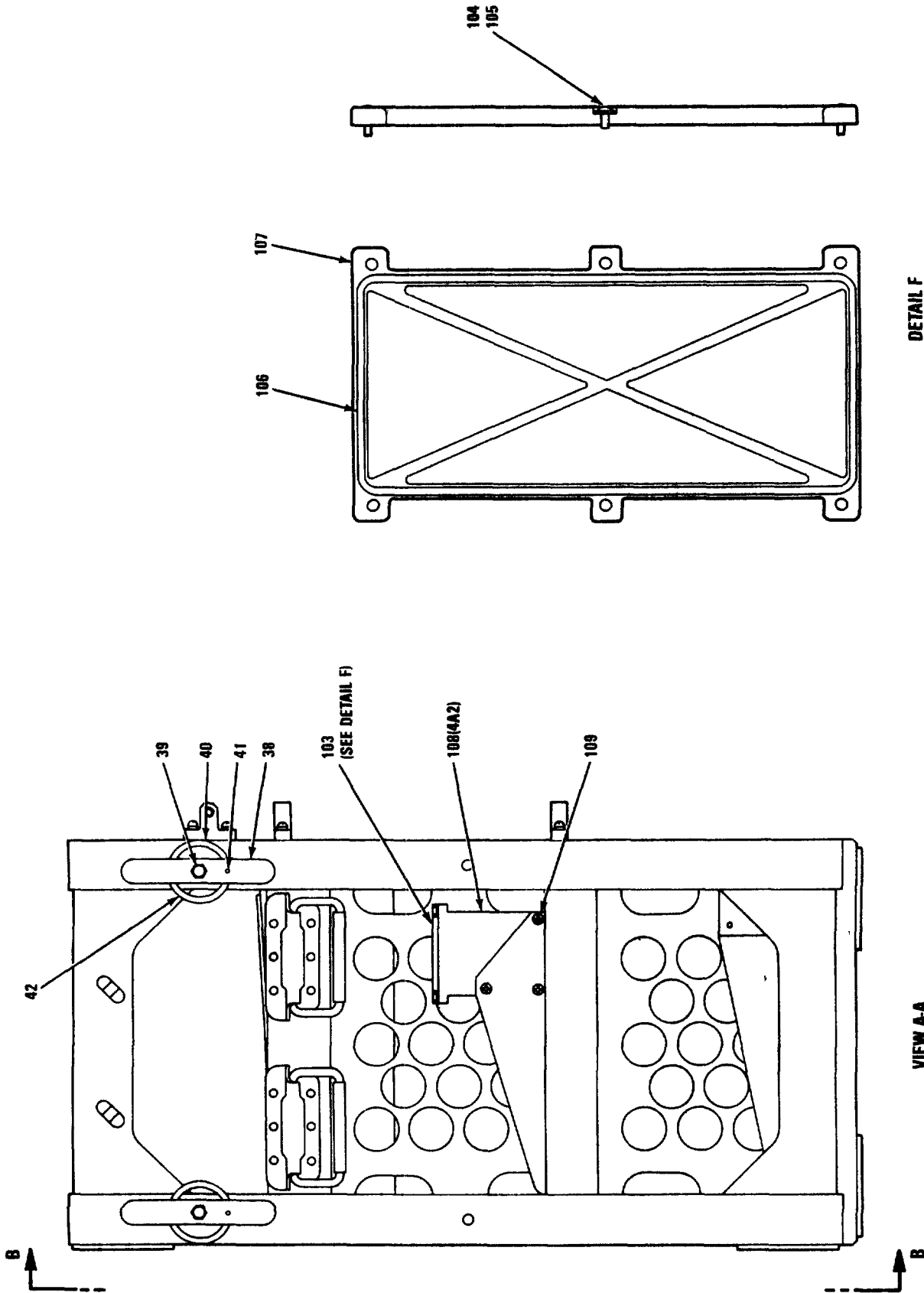

FIGURE 7-24. ELECTRICAL MOUNTING BASE, MT-6250/GRC-206 (SHEET 6 OF 12)

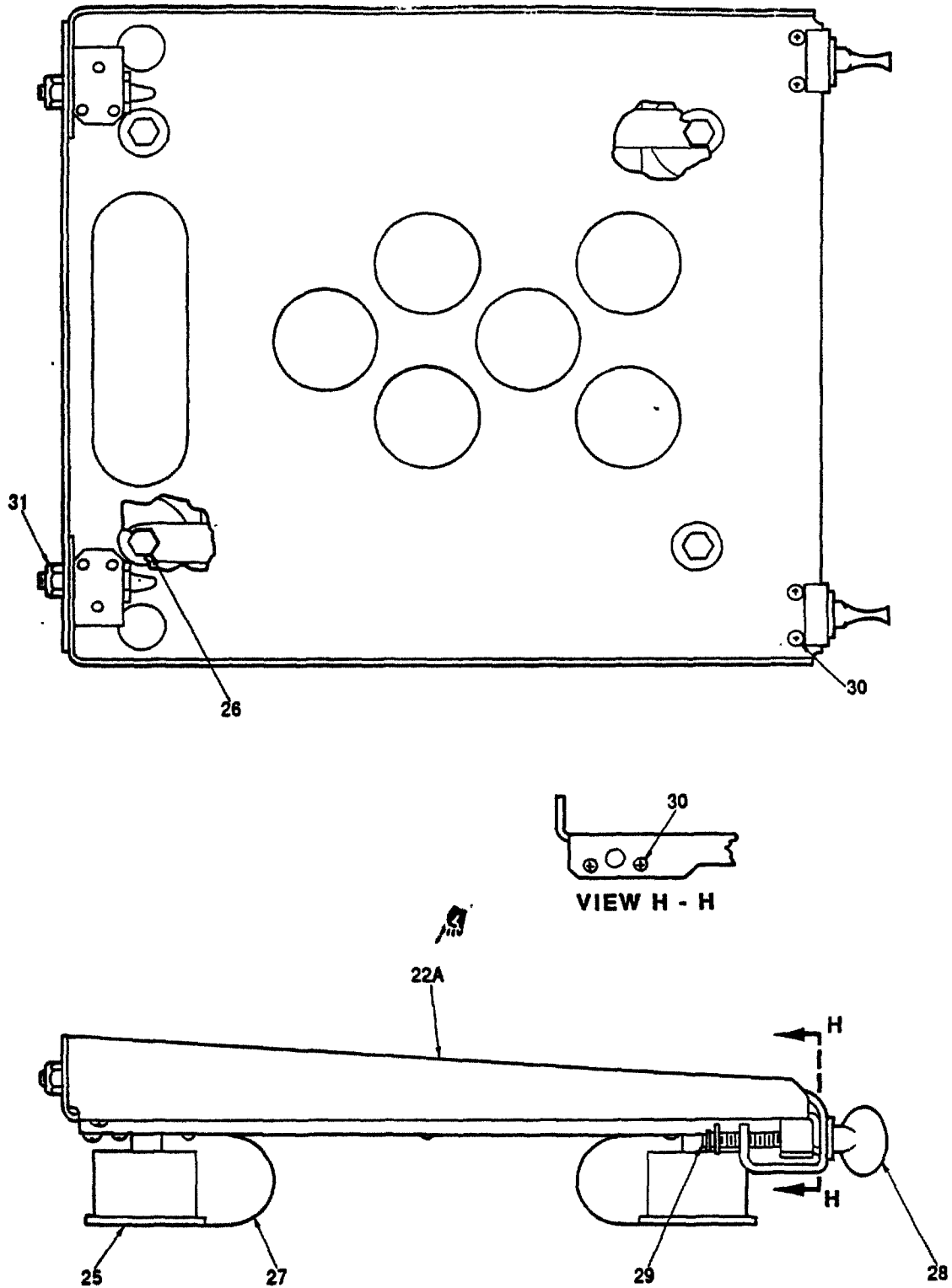
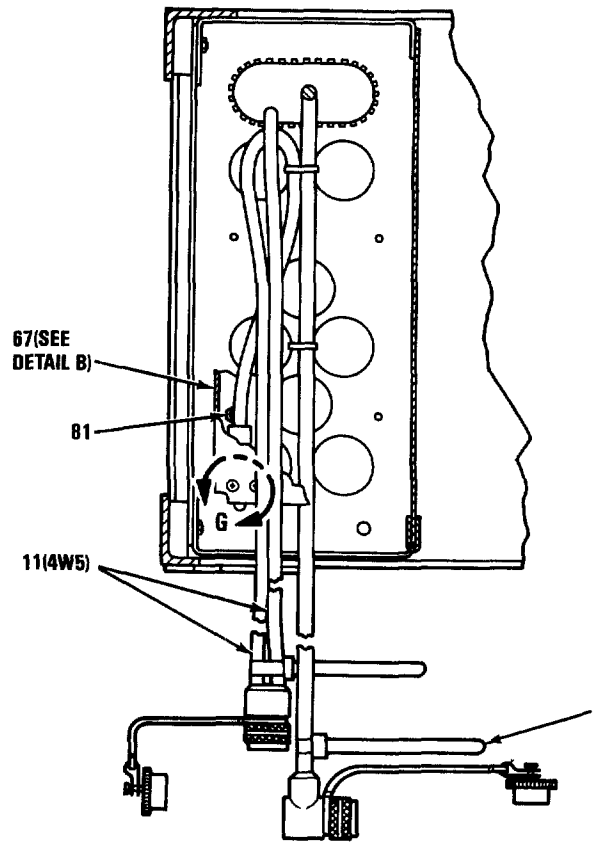
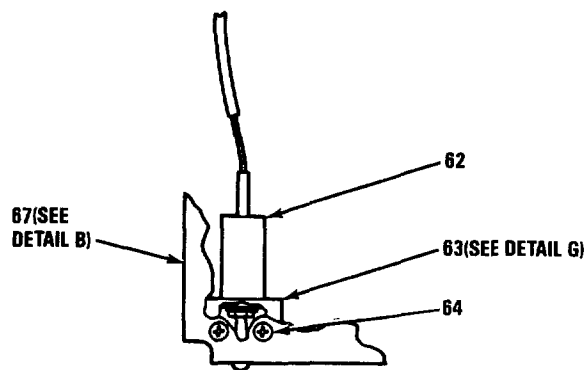

FIGURE 7-24. ELECTRICAL MOUNTING BASE, MT-6250/GRC-206 (SHEET 7 OF 12)



VIEW F-F



VIEW G

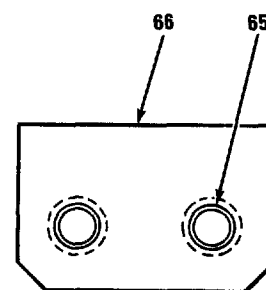

DETAIL G

MX-61-119-IPB-24-8

FIGURE 7-24. ELECTRICAL MOUNTING BASE, MT-6250/0RC-206 (SHEET 8 OF 12)

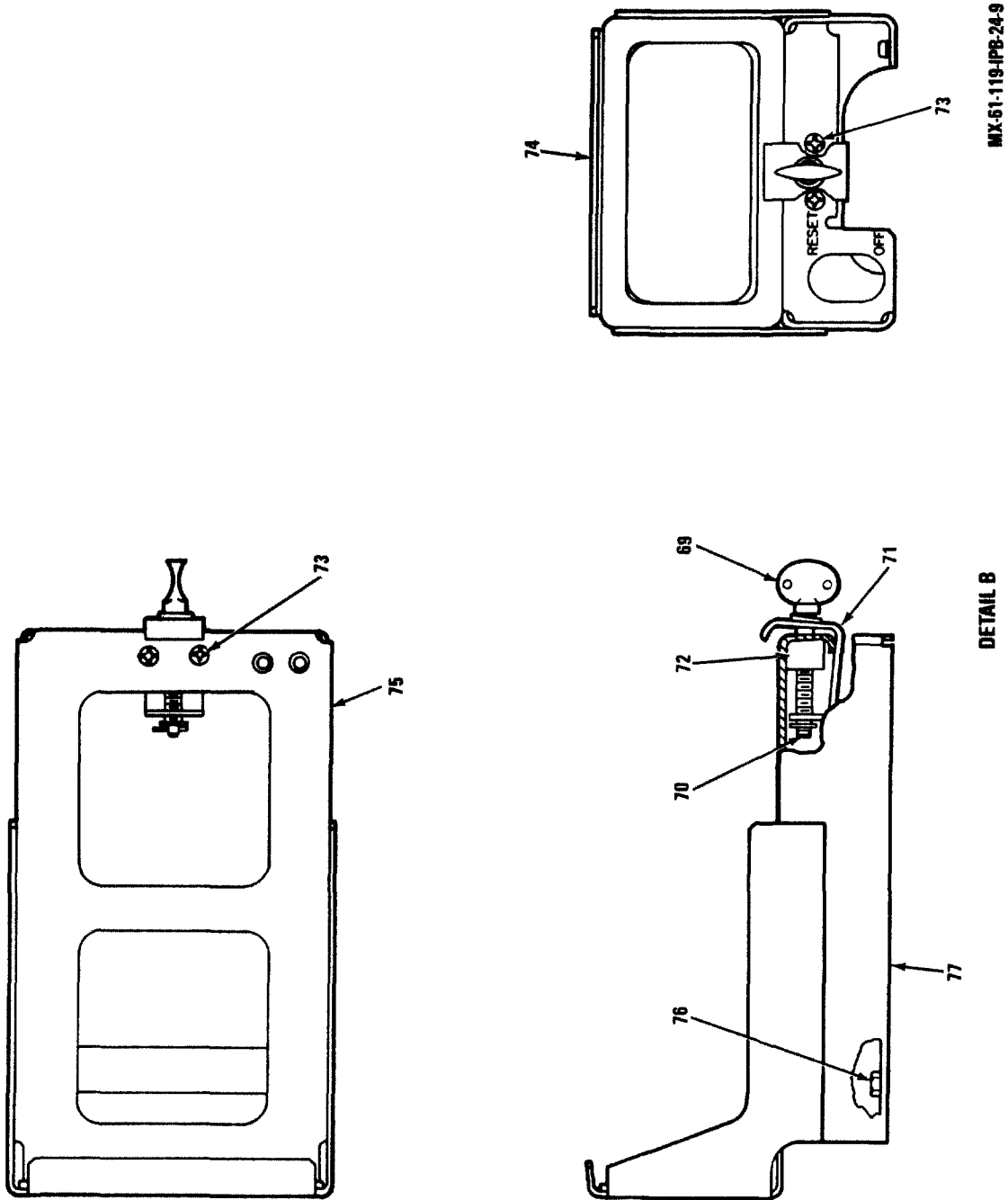
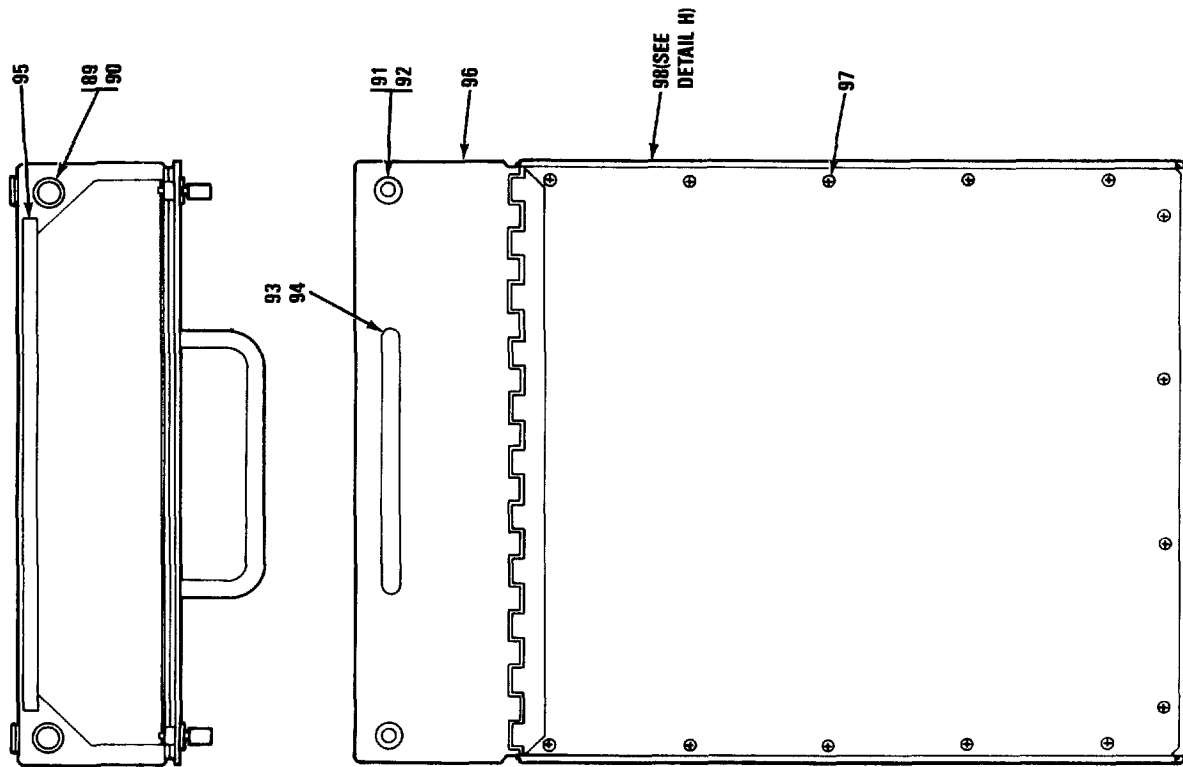
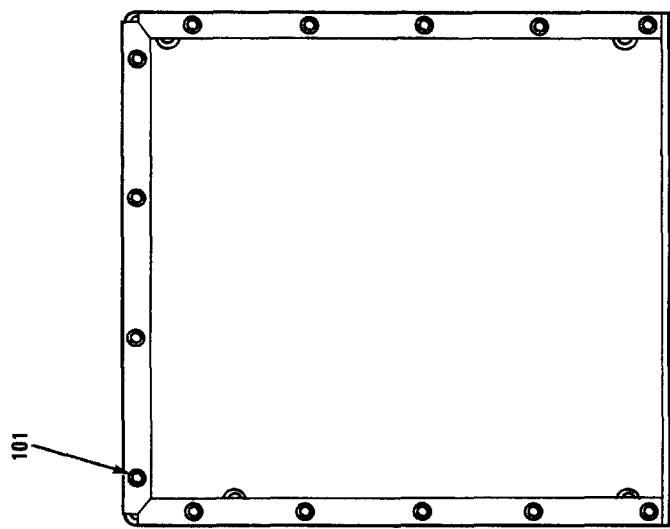

FIGURE 7-24. ELECTRICAL MOUNTING BASE, MT-6250/ORC-206 (SHEET 7 OF 12)



MX-61-119-PPB-24-10

DETAIL C



DETAIL H

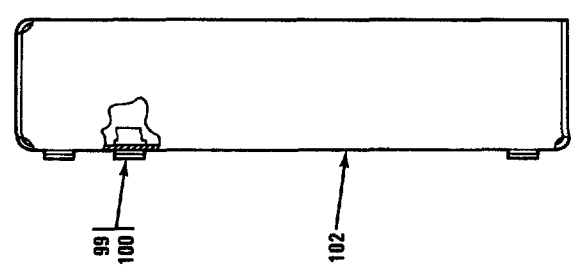

FIGURE 7-24. ELECTRICAL MOUNTING BASE, MT-6250/GRC-206 (SHEET 10 OF 12)

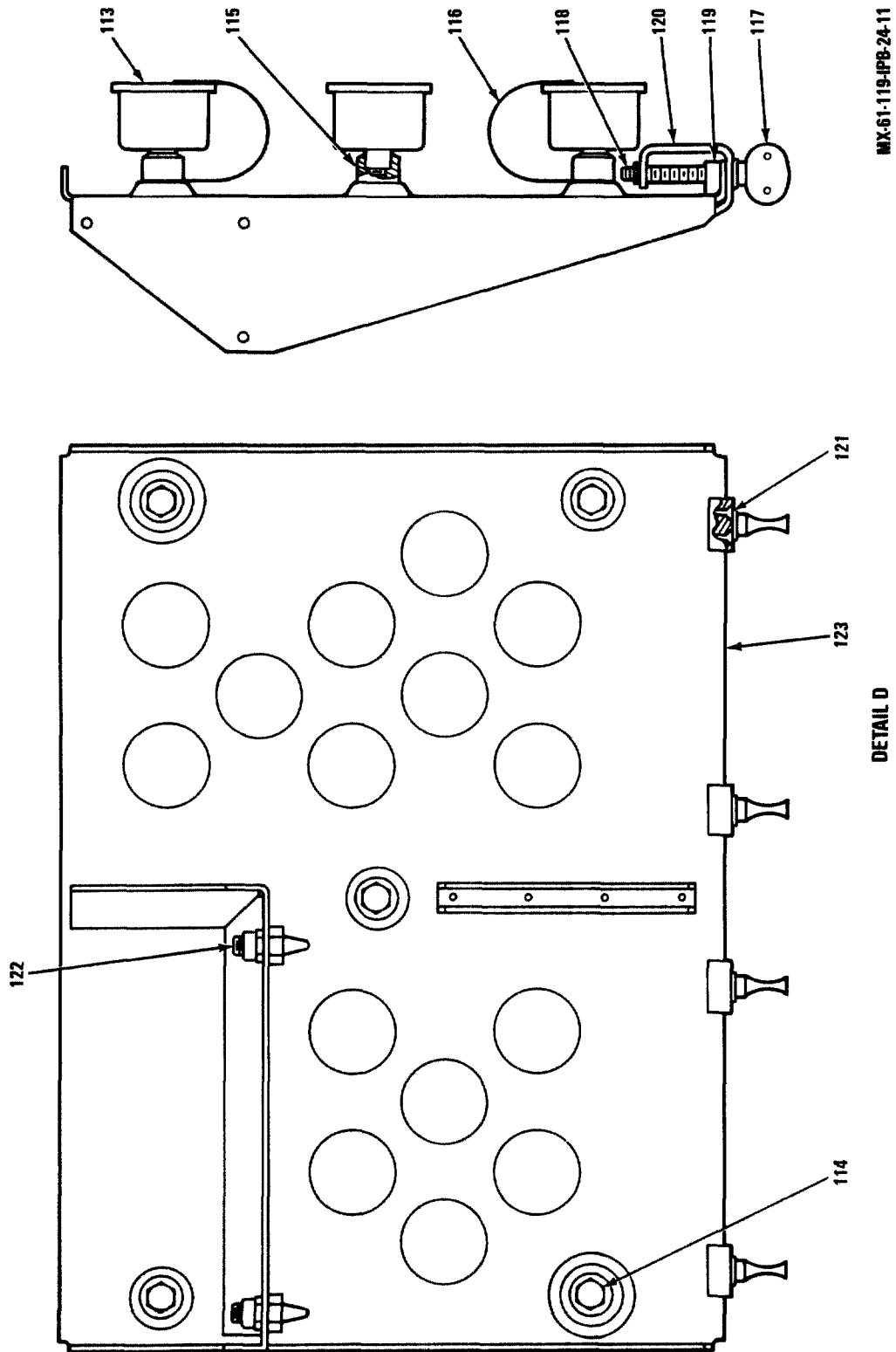

FIGURE 7-24. ELECTRICAL MOUNTING BASE, MT-6250/9RC-206 (SHEET 11 OF 12)

MX-61-119-IPB-24-12

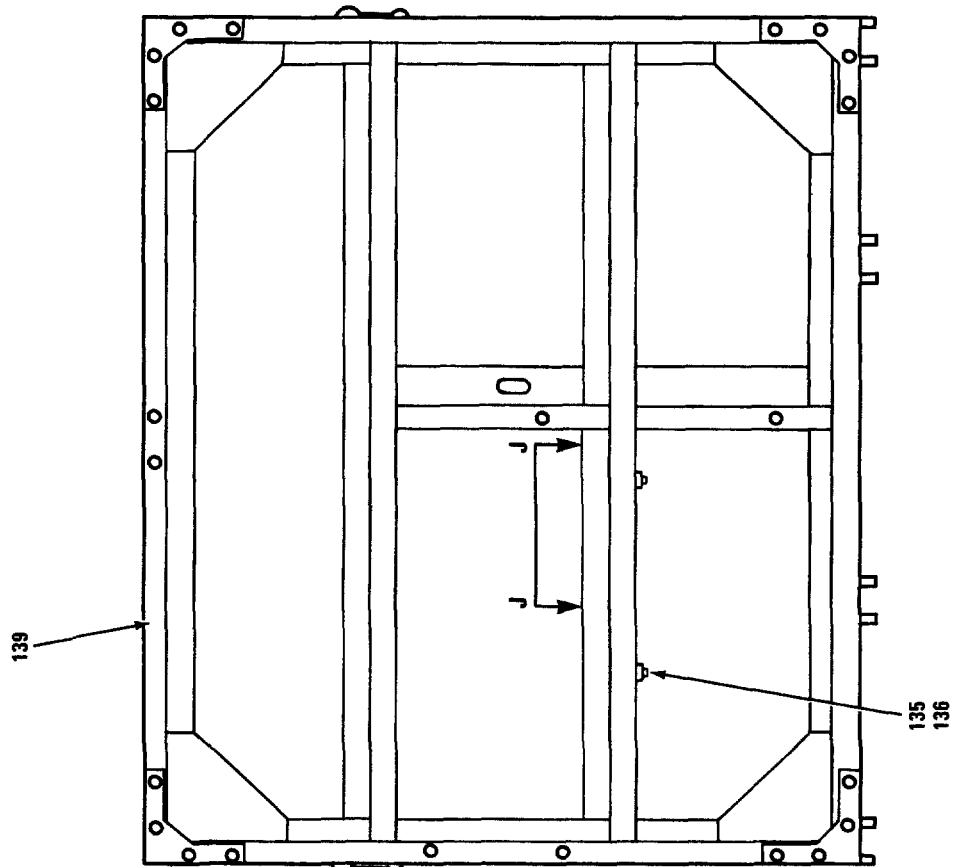
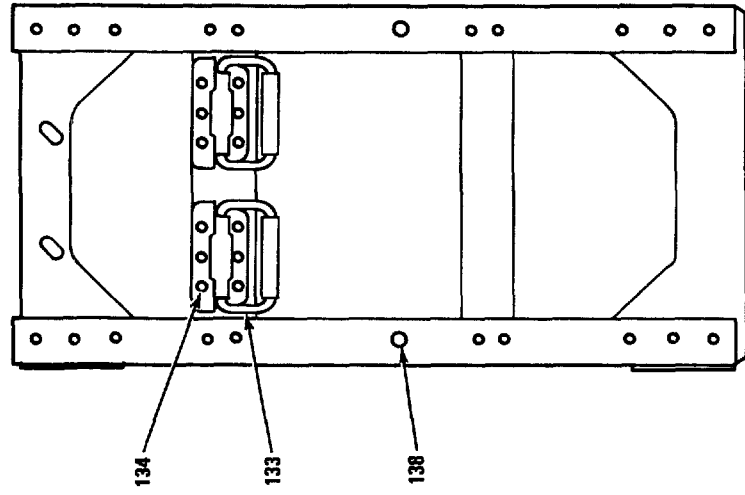
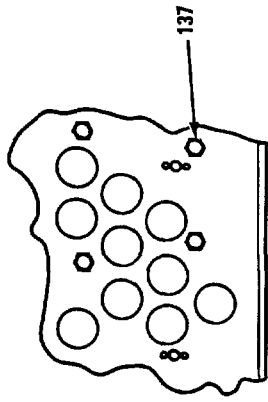

FIGURE 7-24. ELECTRICAL MOUNTING BASE, MT-6250/GRC-206 (SHEET 12 OF 12)

TO 31R2-2GRC206-12

| FIG. &<br>INDEX<br>NUMBER | PART NUMBER    | FSCM  | DESCRIPTION                                       |   |   |   |   |   |   | UNITS<br>PER<br>ASSY | USABLE<br>ON<br>CODE | SMR<br>CODE |
|---------------------------|----------------|-------|---|---|---|---|---|---|---|----------------------|----------------------|-------------|
|                           |                |       | 1   | 2 | 3 | 4 | 5 | 6 | 7 |                      |                      |             |
| 7-24-                     | 812084-801     | 37695 | MOUNTING BASE, ELECTRICAL EQUIPMENT . . . . .     |   |   |   |   |   |   | REF                  | A                    | XB          |
|                           | 812084-802     | 37695 | MT-6250/GRC-206 (SEE FIGURE 7-1 FOR NHA)          |   |   |   |   |   |   | REF                  | B                    | XB          |
|                           |                |       | MOUNTING BASE, ELECTRICAL EQUIPMENT . . . . .     |   |   |   |   |   |   |                      |                      |             |
|                           |                |       | MT-6250A/GRC-206 (SEE FIGURE 7-1 FOR NHA)         |   |   |   |   |   |   |                      |                      |             |
| -1                        | 136617-3       | 37695 | . STRAP, RETAINING . . . . .                      |   |   |   |   |   |   | 13                   |                      | PAFZZ       |
| -2                        | MS3367-1-0     | 96906 | . STRAP, TIEDOWN . . . . .                        |   |   |   |   |   |   | 50                   |                      | PAFZZ       |
| -3                        | 938573-1       | 37695 | . CLIP . . . . .                                  |   |   |   |   |   |   | 8                    | A                    | PAOZZ       |
| -4                        | 348205-6       | 37695 | . COVER . . . . .                                 |   |   |   |   |   |   | 4                    | A                    | XB          |
| -5                        | MS51844-21     | 96906 | . SLEEVE, SWAGING . . . . .                       |   |   |   |   |   |   | 18                   |                      | PADZZ       |
| -6                        | MS3180-14C     | 96906 | . COVER, PROTECTIVE (USED ON CONNECTORS . . . . . |   |   |   |   |   |   | 7                    |                      | PADZZ       |
|                           |                |       | 4W5P1, 4W14P1, 4W15P2 AND 4W18P1)                 |   |   |   |   |   |   |                      |                      |             |
|                           | MS3180-12C     | 96906 | . COVER, PROTECTIVE (USED ON . . . . .            |   |   |   |   |   |   | 1                    | A                    | PADZZ       |
|                           |                |       | CONNECTOR 4W2P1)                                  |   |   |   |   |   |   |                      |                      |             |
|                           | MS3180-16C     | 96906 | . COVER, PROTECTIVE (USED ON CONNECTOR . . . . .  |   |   |   |   |   |   | 1                    | A                    | PADZZ       |
|                           |                |       | 4W10P2)   |   |   |   |   |   |   |                      |                      |             |
| -7                        | 566085-801     | 37695 | . CABLE ASSEMBLY . . . . .                        |   |   |   |   |   |   | 1                    |                      | PBOZZ       |
| -8                        | 566085-802     | 37695 | . CABLE ASSEMBLY . . . . .                        |   |   |   |   |   |   | 1                    | A                    | PBOZZ       |
| -9                        | 566085-803     | 37695 | . CABLE ASSEMBLY . . . . .                        |   |   |   |   |   |   | 1                    |                      | PBOZZ       |
| -10                       | 566085-804     | 37695 | . CABLE ASSEMBLY . . . . .                        |   |   |   |   |   |   | 1                    |                      | PBOZZ       |
| -11                       | 566085-805     | 37695 | . CABLE ASSEMBLY . . . . .                        |   |   |   |   |   |   | 1                    | A                    | PBOZZ       |
| -12                       | 566085-806     | 37695 | . CABLE ASSEMBLY . . . . .                        |   |   |   |   |   |   | 1                    |                      | PBOZZ       |
| -13                       | 566083-801     | 37695 | . CABLE ASSEMBLY . . . . .                        |   |   |   |   |   |   | 1                    |                      | PBOZZ       |
| -14                       | 566084-801     | 37695 | . CABLE ASSEMBLY . . . . .                        |   |   |   |   |   |   | 1                    | A                    | PBOZZ       |
| -15                       | 566084-804     | 37695 | . CABLE ASSEMBLY . . . . .                        |   |   |   |   |   |   | 1                    |                      | PBOZZ       |
| -16                       | 566084-802     | 37695 | . CABLE ASSEMBLY . . . . .                        |   |   |   |   |   |   | 1                    |                      | PBOZZ       |
| -17                       | 566083-802     | 37695 | . CABLE ASSEMBLY . . . . .                        |   |   |   |   |   |   | 1                    |                      | PBOZZ       |
| -18                       | 566084-805     | 37695 | . CABLE ASSEMBLY . . . . .                        |   |   |   |   |   |   | 1                    | A                    | PBOZZ       |
| -19                       | 566083-803     | 37695 | . CABLE ASSEMBLY . . . . .                        |   |   |   |   |   |   | 1                    |                      | PBOZZ       |
| -20                       | 566078-802     | 37695 | . CABLE ASSEMBLY . . . . .                        |   |   |   |   |   |   | 1                    |                      | MFF         |
| -21                       | M39012/16-0101 | 81349 | . . CONNECTOR . . . . .                           |   |   |   |   |   |   | 1                    |                      | PAFZZ       |
| -22                       | M39012/20-0101 | 81349 | . . CONNECTOR . . . . .                           |   |   |   |   |   |   | 1                    |                      | PAFZZ       |
| -23                       | 566084-803     | 37695 | . CABLE ASSEMBLY . . . . .                        |   |   |   |   |   |   | 1                    |                      | PBOZZ       |
| -24                       | 566083-804     | 37695 | . CABLE ASSEMBLY . . . . .                        |   |   |   |   |   |   | 1                    | A                    | PBOZZ       |
| -25                       | 566083-805     | 37695 | . CABLE ASSEMBLY . . . . .                        |   |   |   |   |   |   | 1                    | A                    | PBOZZ       |
| -26                       | 514993-1       | 37695 | . PLUG, BUSHING . . . . .                         |   |   |   |   |   |   | 1                    |                      | XB          |
| -27                       | MS3461/1-017   | 81349 | . PACKING . . . . .                               |   |   |   |   |   |   | 1                    |                      | PAFZZ       |
| -28                       | MS25082C11     | 96906 | . NUT . . . . .                                   |   |   |   |   |   |   | 1                    |                      | PAFZZ       |
| -29                       | 156014-4*      | 37695 | . LABEL, WARNING . . . . .                        |   |   |   |   |   |   | 1                    |                      | MDD         |
| -30                       | 938770-6       | 37695 | . STRAP, GROUND . . . . .                         |   |   |   |   |   |   | 1                    |                      | XB          |
| -31                       | MS51958-61     | 96906 | . SCREW (AP) . . . . .                            |   |   |   |   |   |   | 1                    |                      | PAFZZ       |
|                           | MS35338-138    | 96906 | . WASHER (AP) . . . . .                           |   |   |   |   |   |   | 1                    |                      | PAFZZ       |
|                           | NAS620C10      | 80205 | . WASHER (AP) . . . . .                           |   |   |   |   |   |   | 1                    |                      | PAFZZ       |
| -32                       | MS21333-73     | 96906 | . CLAMP, LOOP . . . . .                           |   |   |   |   |   |   | 2                    |                      | PAFZZ       |
| -33                       | MS51958-69     | 96906 | . SCREW (AP) . . . . .                            |   |   |   |   |   |   | 2                    |                      | PAFZZ       |
|                           | MS35338-138    | 96906 | . WASHER (AP) . . . . .                           |   |   |   |   |   |   | 2                    |                      | PAFZZ       |
|                           | NAS620C10      | 80205 | . WASHER (AP) . . . . .                           |   |   |   |   |   |   | 2                    |                      | PAFZZ       |
|                           | 349066-2       | 37695 | . SPACER, HF CABLE/RACK (AP) . . . . .            |   |   |   |   |   |   | 1                    |                      | PAFZZ       |
| -34                       | 349066-1       | 37695 | . SPACER, HF CABLE/RACK . . . . .                 |   |   |   |   |   |   | 1                    |                      | PAFZZ       |
| -35                       | MS51958-64     | 96906 | . SCREW (AP) . . . . .                            |   |   |   |   |   |   | 2                    |                      | PAFZZ       |
|                           | MS35338-138    | 96906 | . WASHER (AP) . . . . .                           |   |   |   |   |   |   | 2                    |                      | PAFZZ       |
|                           | NAS620C10      | 80205 | . WASHER (AP) . . . . .                           |   |   |   |   |   |   | 2                    |                      | PAFZZ       |
| -36                       | 155896-*       | 37695 | . PLATE, IDENTIFICATION . . . . .                 |   |   |   |   |   |   | 1                    |                      | MDD         |
| -37                       | MS51957-11     | 96906 | . SCREW (AP) . . . . .                            |   |   |   |   |   |   | 2                    |                      | PAFZZ       |
| -38                       | 515166-1       | 37695 | . BAR, RETAINER . . . . .                         |   |   |   |   |   |   | 2                    |                      | XB          |
| -39                       | MS35307-341    | 96906 | . SCREW (AP) . . . . .                            |   |   |   |   |   |   | 1                    |                      | PAFZZ       |
|                           | MS17830-5C     | 96906 | . NUT (AP) . . . . .                              |   |   |   |   |   |   | 1                    |                      | PAFZZ       |
| -40                       | 515167-801     | 37695 | . BAR, RETAINER . . . . .                         |   |   |   |   |   |   | 2                    |                      | XB          |
| -41                       | MS171496       | 96906 | . . PIN . . . . .                                 |   |   |   |   |   |   | 2                    |                      | PAFZZ       |
| -42                       | 515167-1       | 37695 | . . HUB, MOUNTING . . . . .                       |   |   |   |   |   |   | 1                    |                      | XA          |
| -43                       | 812097-801     | 37695 | . MOUNT, VRC-83 . . . . .                         |   |   |   |   |   |   | 2                    |                      | XB          |
| -44                       | MS24693C51     | 96906 | . SCREW (AP) . . . . .                            |   |   |   |   |   |   | 4                    |                      | PAFZZ       |
|                           | MS21044C08     | 96906 | . NUT (AP) . . . . .                              |   |   |   |   |   |   | 4                    |                      | PAFZZ       |
| -45                       | MS51957-46     | 96906 | . SCREW (AP) . . . . .                            |   |   |   |   |   |   | 12                   |                      | PAFZZ       |
|                           | MS21044C08     | 96906 | . NUT (AP) . . . . .                              |   |   |   |   |   |   | 12                   |                      | PAFZZ       |
| -46                       | T44-AB-10      | 81860 | . . MOUNT, RESILIENT (MAGNAVOX SPEC. . . . .      |   |   |   |   |   |   | 4                    |                      | PAFZZ       |
|                           |                |       | CONT DWG 435653-4)                                |   |   |   |   |   |   |                      |                      |             |



| FIG. &<br>INDEX<br>NO. | PART NUMBER   | FSCM  | DESCRIPTION                      | UNITS       | USABLE     | SMR<br>CODE |
|------------------------|---------------|-------|----------------------------------|-------------|------------|-------------|
|                        |               |       |                                  | PER<br>ASSY | ON<br>CODE |             |
| 7-24-47                | MS35308-303   | 96906 | . . SCREW (AP).....              | 1           |            | PAFZZ       |
|                        | MS35338-139   | 96906 | . . WASHER (AP).....             | 1           |            | PAFZZ       |
| -48                    | 938770-1      | 37695 | . . STRAP, GROUND.....           | 2           |            | PAFZZ       |
| -49                    | 136539-1      | 37695 | . . THUMBSCREW.....              | 2           |            | PAFZZ       |
| -50                    | MS24665-151   | 96906 | . . PIN (AP).....                | 1           |            | PAFZZ       |
|                        | NAS620C10     | 80205 | . . WASHER (AP).....             | 1           |            | PAFZZ       |
|                        | MS15795-810   | 96906 | . . WASHER (AP).....             | 1           |            | PAFZZ       |
| -51                    | 938712-3      | 37695 | . . CLAMP, MOUNTING.....         | 2           |            | XB          |
| -52                    | MS24693C3     | 96906 | . . SCREW (AP).....              | 8           |            | PAFZZ       |
| -53                    | 514863-1      | 37695 | . . BLOCK, MOUNTING CLAMP.....   | 2           |            | XB          |
| -54                    | 515618-1      | 37695 | . . BLOCK, RETAINING PIN.....    | 2           |            | XB          |
| -55                    | MS51958-64    | 96906 | . . SCREW (AP).....              | 2           |            | PAFZZ       |
|                        | MS21044C5     | 96906 | . . NUT (AP).....                | 1           |            | PAFZZ       |
|                        | 136279-4      | 37695 | . . PIN, RETAINER (AP).....      | 1           |            | PAFZZ       |
| -56                    | 938668-801    | 37695 | . . TRAY, VRC-83 MOUNT.....      | 1           |            | XA          |
| -56A                   | 651-8472-001  | 13499 | . BASE, SHOCK MOUNT/AM-7148..... | 1           |            | XB          |
| -57                    | 938668-1      | 37695 | . . . TRAY, VRC-83 MOUNT.....    | 1           |            | XA          |
| -58                    | 938668-2      | 37695 | . . . TRAY, VRC-83 MOUNT.....    | 2           |            | XA          |
| -59                    | MS20426AD6-10 | 96906 | . . . RIVET (AP).....            | 14          |            | PADZZ       |
| -60                    | 626701-2      | 37695 | . TRAY, HF POWER AMP.....        | 1           |            | XB          |
| -61                    | MS51957-46    | 96906 | . SCREW.....                     | 16          |            | PAFZZ       |
|                        | MS21044C08    | 96906 | . NUT.....                       | 16          |            | PAFZZ       |
| -62                    | M39019/01-218 | 81349 | . CIRCUIT BREAKER.....           | 1           | A          | PAFZZ       |
| -63                    | 938713-801    | 37695 | . BRACKET, MOUNTING.....         | 3           | A          | XB          |
| -64                    | MS24693C26    | 96906 | . SCREW (AP).....                | 2           | A          | PAFZZ       |
| -65                    | M45938/5-6C   | 96906 | . . NUT.....                     | 2           | A          | PAFZZ       |
| -66                    | 938713-1      | 37695 | . . BRACKET, MOUNTING.....       | 1           | A          | XA          |
| -67                    | 812137-801    | 37695 | . MOUNT, KY-57.....              | 3           | A          | XB          |
| -68                    | MS51957-45    | 96906 | . SCREW (AP).....                | 4           | A          | PAFZZ       |
| -69                    | 136539-1      | 37695 | . . THUMBSCREW.....              | 1           | A          | PAFZZ       |
| -70                    | NAS620C10     | 80205 | . . WASHER (AP).....             | 1           | A          | PAFZZ       |
|                        | MS15795-810   | 96906 | . . WASHER (AP).....             | 1           | A          | PAFZZ       |
|                        | MS24665-151   | 96906 | . . PIN (AP).....                | 1           | A          | PAFZZ       |
| -71                    | 938712-1      | 37695 | . . CLAMP, MOUNTING.....         | 1           | A          | XB          |
| -72                    | 514863-1      | 37695 | . . BLOCK, MOUNTING CLAMP.....   | 1           | A          | XB          |
| -73                    | MS24693C3     | 96906 | . . SCREW (AP).....              | 4           | A          | PAFZZ       |
| -74                    | 348763-1      | 37695 | . . PAD, RUBBER.....             | 1           | A          | XB          |
| -75                    | 938676-801    | 37695 | . . TRAY, KY-57 MOUNT.....       | 1           | A          | XA          |
| -76                    | M45938/5-7C   | 81349 | . . . NUT.....                   | 4           | A          | PAFZZ       |
| -77                    | 938676-1      | 37695 | . . . TRAY, KY-57 MOUNT.....     | 1           | A          | XB          |
| -78                    | 939189-801    | 37695 | . SHELF, KY-57.....              | 1           | A          | XB          |
| -79                    | MS51957-46    | 96906 | . SCREW (AP).....                | 5           | A          | PAFZZ       |
| -80                    | MS24693C279   | 96906 | . SCREW (AP).....                | 2           | A          | PAFZZ       |
| -81                    | MS24693C49    | 96906 | . SCREW (AP).....                | 4           | A          | PAFZZ       |
| -82                    | MS21076L08    | 96906 | . . NUT.....                     | 5           | A          | PAFZZ       |
| -83                    | MS20426AD3-6  | 96906 | . . RIVET (AP).....              | 10          | A          | XB          |
| -84                    | MS21076L3     | 96906 | . . NUT.....                     | 2           | A          | PAFZZ       |
| -85                    | MS20426AD3-8  | 96906 | . . RIVET (AP).....              | 4           | A          | XA          |
| -86                    | 939189-1      | 37695 | . . SHELF, MOUNTING.....         | 1           | A          | XA          |
| -87                    | 813199-801    | 37695 | . BOX, STORAGE.....              | 1           |            | XB          |
| -88                    | MS51958-65    | 96906 | . SCREW (AP).....                | 4           |            | PAFZZ       |
|                        | MS35338-138   | 96906 | . WASHER (AP).....               | 4           |            | PAFZZ       |



| FIG &<br>INDEX<br>NO. | PART<br>NUMBER | FSCM  | DESCRIPTION |   |   |   |   |   |   | UNITS<br>PER<br>ASSY | USABLE<br>ON<br>CODE | SMR<br>CODE |
|-----------------------|----------------|-------|-------------|---|---|---|---|---|---|----------------------|----------------------|-------------|
|                       |                |       | 1           | 2 | 3   | 4 | 5 | 6 | 7 |                      |                      |             |
| 7-24-89               | 15R1-1AC       | 71286 | .           | . | RECEPTACLE, TURNLOCK (MAGNAVOX.....<br>SPEC CONT DWG 135143-1)                |   |   |   |   | 2                    |                      | PAFZZ       |
| -90                   | MS25082-21     | 96906 | .           | . | NUT (AP).....   |   |   |   |   | 1                    |                      | PAFZZ       |
| -91                   | 15S1-3-1AC     | 71286 | .           | . | STUD, PUSHBUTTON FASTENER.....<br>(MAGNAVOX SPEC CONT DWG 135144-<br>102)     |   |   |   |   | 2                    |                      | PAFZZ       |
| -92                   | 15S-11-2AE     | 71286 | .           | . | SOCKET, PUSHBUTTON FASTENER.....<br>(MAGNAVOX SPEC CONT DWG 135182-1)<br>(AP) |   |   |   |   | 1                    |                      | PAFZZ       |
| -93                   | MS39087-4      | 96906 | .           | . | HANDLE .....  |   |   |   |   | 1                    |                      | XB          |
| -94                   | M824693C269    | 96906 | .           | . | SCREW.....  |   |   |   |   | 2                    |                      | PAFZZ       |
| -95                   | 348297-9       | 37695 | .           | . | PAD, RUBBER.....  |   |   |   |   | 1                    |                      | XB          |
| -96                   | 939463-801     | 37695 | .           | . | BOTTOM, STOWAGE BOX.....  |   |   |   |   | 1                    |                      | XA          |
| -97                   | MS24693C1      | 96906 | .           | . | SCREW (AP) .....  |   |   |   |   | 14                   |                      | PAFZZ       |
| -98                   | 939462-801     | 37695 | .           | . | TOP, STOWAGE BOX.....   |   |   |   |   | 1                    |                      | XA          |
| -99                   | SS10R180       | 03481 | .           | . | NUT, INSERT (MAGNAVOX SPEC.....<br>CONT DWG 136568-28)                        |   |   |   |   | 4                    |                      | XB          |

| FIG & INDEX NO.  | PART NUMBER        | FSCM  | DESCRIPTION |   |   |  |   |   |   | UNITS PER ASSY | USABLE ON CODE | SMR CODE |
|--|--------------------|-------|-------------|---|---|--|---|---|---|----------------|----------------|----------|
|  |                    |       | 1           | 2 | 3 | 4  | 5 | 6 | 7 |                |                |          |
| 7-24-100   | NAS620C416         | 80205 | .           | . | . | WASHER .....   |   |   |   | 4              |                | PAFZZ    |
| -101   | M45938/4-3         | 81349 | .           | . | . | NUT.....   |   |   |   | 14             |                | XB       |
| -102   | 939462-1           | 37695 | .           | . | . | TOP, STOWAGE BOX.....  |   |   |   | 1              |                | XA       |
| -103   | 660153-801         | 37695 | .           | . | . | COVER, POWER JUNCTION UNIT.....                                      |   |   |   | 1              |                | XB       |
| -104   | 136555-1           | 37695 | .           | . | . | SCREW, MODIFIED.....   |   |   |   | 6              |                | PAFZZ    |
| -105   | NAS620C6           | 80205 | .           | . | . | WASHER.....  |   |   |   | 6              |                | PAFZZ    |
| -106   | 348403-1           | 37695 | .           | . | . | GASKET, RUBBER.....  |   |   |   | 1              |                | XA       |
| -107   | 660153-1           | 37695 | .           | . | . | COVER, POWER JUNCTION.....   |   |   |   | 1              |                | XA       |
| -108   | 812119-801         | 37695 | .           | . | . | DISTRIBUTION BOX (SEE FIGURE 7-25.....<br>FOR BKDN)                  |   |   |   | 1              |                | PAODD    |
| -109   | MS51957-43         | 96906 | .           | . | . | SCREW (AP).....  |   |   |   | 6              |                | PAFZZ    |
|  | MS35338-137        | 96906 | .           | . | . | WASHER (AP).....   |   |   |   | 6              |                | PAFZZ    |
| -110   | 812098-801         | 37695 | .           | . | . | MOUNT, POWER DISTRIBUTION.....                                       |   |   |   | 1              |                | XB       |
| -111   | MS51957-46         | 96906 | .           | . | . | SCREW (AP).....  |   |   |   | 12             |                | PAFZZ    |
|  | MS21044C08         | 96906 | .           | . | . | NUT (AP).....  |   |   |   | 12             |                | PAFZZ    |
| -112   | MS24693C51         | 96906 | .           | . | . | SCREW (AP).....  |   |   |   | 4              |                | PAFZZ    |
|  | MS21044C08         | 96906 | .           | . | . | NUT (AP).....  |   |   |   | 4              |                | PAFZZ    |
| -113   | T44-AB-10          | 81860 | .           | . | . | MOUNT, RESILIENT (MAGNAVOX SPEC.....<br>CONT DWG 435653-4)           |   |   |   | 5              |                | PAFZZ    |
| -114   | MS35308-306        | 96906 | .           | . | . | SCREW (AP).....  |   |   |   | 1              |                | PAFZZ    |
|  | MS35338-139        | 96906 | .           | . | . | WASHER (AP).....   |   |   |   | 1              |                | PAFZZ    |
| -115   | 515168-1           | 37695 | .           | . | . | SPACER, MOUNTING.....  |   |   |   | 5              |                | XB       |
| -116   | 938770-1           | 37695 | .           | . | . | STRAP, GROUND.....   |   |   |   | 2              |                | PAFZZ    |
| -117   | 136539-1           | 37695 | .           | . | . | THUMBSCREW.....  |   |   |   | 4              |                | PAFZZ    |
| -118   | NAS620C10          | 80205 | .           | . | . | WASHER (AP).....   |   |   |   | 1              |                | PAFZZ    |
|  | MS15795-810        | 96906 | .           | . | . | WASHER (AP).....   |   |   |   | 1              |                | PAFZZ    |
|  | MS24665-151        | 96906 | .           | . | . | PIN (AP).....  |   |   |   | 1              |                | PAFZZ    |
| -119   | 515357-1           | 37695 | .           | . | . | BAR, MOUNTING.....   |   |   |   | 1              |                | XB       |
| -120   | 938712-2           | 37695 | .           | . | . | CLAMP, MOUNTING.....   |   |   |   | 4              |                | XB       |
| -121   | MS24693C3          | 96906 | .           | . | . | SCREW (AP).....  |   |   |   | 8              |                | PAFZZ    |
| -122   | MS21044C5          | 96906 | .           | . | . | NUT.....   |   |   |   | 2              |                | PAFZZ    |
|  | 136279-3           | 37695 | .           | . | . | PIN, RETAINER.....   |   |   |   | 2              |                | XB       |
| -123   | 938719-801         | 37695 | .           | . | . | TRAY, MOUNTING.....  |   |   |   | 1              |                | XA       |
| -124   | 812132-801         | 37695 | .           | . | . | INTERFACE ASSEMBLY, FM BITE/AUDIO.....<br>(SEE FIGURE 7-26 FOR BKDN) |   |   |   | 1              |                | PAOLD    |
| -125   | MS35308-332        | 96906 | .           | . | . | SCREW.....   |   |   |   | 4              | A              | PAFZZ    |
| -126   | 938770-2           | 37695 | .           | . | . | STRAP, GROUND.....   |   |   |   | 2              | A              | XB       |
| -127   | 938770-4           | 37695 | .           | . | . | STRAP, GROUND.....   |   |   |   | 1              | A              | XB       |
| -128   | MS35307-334        | 96906 | .           | . | . | SCREW.....   |   |   |   | 4              |                | PAFZZ    |
|  | MS17830-5C         | 96906 | .           | . | . | NUT.....   |   |   |   | 6              |                | PAFZZ    |
| -129   | 938770-3           | 37695 | .           | . | . | STRAP, GROUND.....   |   |   |   | 1              |                | XB       |
| -130   | 136383-2           | 37695 | .           | . | . | FOOT, RUBBER.....  |   |   |   | 4              |                | XB       |
| -131   | MS16995-49         | 96906 | .           | . | . | SCREW (AP).....  |   |   |   | 2              |                | PAFZZ    |
| -132   | 514816-801         | 37695 | .           | . | . | RACK, EQUIPMENT MOUNTING.....  |   |   |   | 1              |                | XB       |
| -133   | H9955-SS-2-RQ-1200 | 98003 | .           | . | . | HANDLE, BAIL (MAGNAVOX SPEC.....<br>CONT DWG 128324-1)               |   |   |   | 4              |                | XB       |
| -134   | MS20470A6-9        | 96906 | .           | . | . | RIVET (AP).....  |   |   |   | 6              |                | XB       |
| -135   | MS21076L5          | 96906 | .           | . | . | NUT.....   |   |   |   | 4              |                | PAFZZ    |
| -136   | MS20426AD4-8       | 96906 | .           | . | . | RIVET (AP).....  |   |   |   | 2              |                | XB       |
| -137   | M45938/4-10        | 81349 | .           | . | . | NUT.....   |   |   |   | 4              |                | PAFZZ    |
| -138   | MS122085           | 96906 | .           | . | . | INSERT.....  |   |   |   | 4              |                | XB       |
| -139   | 514816-1           | 37695 | .           | . | . | RACK, EQUIPMENT MOUNTING.....  |   |   |   | 1              |                | XA       |
| A-USED ON 812084-801 ONLY<br>B-USED ON 812084-802 ONLY |                    |       |             |   |   |  |   |   |   |                |                |          |

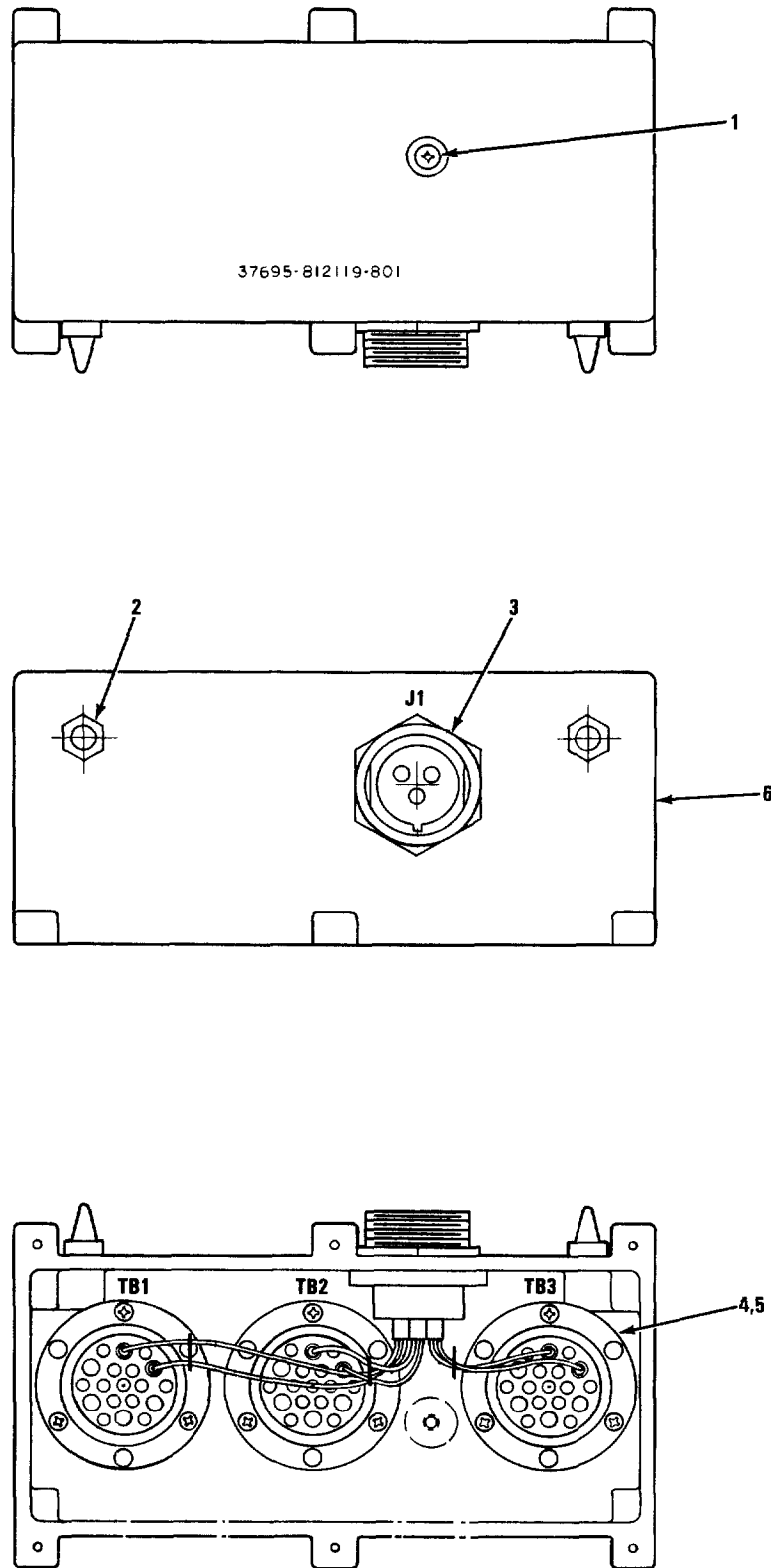

NOTE: REFERENCE DESIGNATIONS ARE ABBREVIATED.  
PREFIX WITH 4A2.

MX-61-119-IPB-25  
REF MAG DWG 812119 REV A  
PL 812119 REV L

FIGURE 7-25. DISTRIBUTION BOX

| FIG. &<br>INDEX<br>NO. | PART NUMBER   | FSCM  | 1234567 | DESCRIPTION   | UNITS<br>PER<br>ASSY. | USABLE<br>ON<br>CODE | SMR<br>CODE |
|------------------------|---------------|-------|---------|---|-----------------------|----------------------|-------------|
| 7-25-                  | 812119-801    | 37695 |         | DISTRIBUTION BOX (SEE FIGURE . . . . REF<br>7-24 FOR NHA)       |                       |                      | PAODD       |
| -1                     | M83213-31     | 96906 |         | SCREW . . . . .   | 1                     |                      | PAFZZ       |
| -2                     | 136279-1      | 37695 |         | PIN, RETAINER. . . . .  | 2                     |                      | XB          |
| -3                     | CA111384      | 71468 |         | CONNECTOR, RECEPTACLE (MAGNAVOX. . .<br>SPEC CONT DWG 186189-1) | 1                     |                      | XB          |
| -4                     | HDJ-24-198 AS | 11139 |         | CONTACT SET, BUSS (MAGNAVOX. . . . .<br>SPEC CONT DWG 205354-1) | 3                     |                      | PADZZ       |
| -5                     | M851957-18    | 96906 |         | SCREW (AP). . . . .   | 9                     |                      | PAFZZ       |
|                        | NAS620C4      | 80205 |         | WASHER (AP) . . . . .   | 9                     |                      | PAFZZ       |
|                        | MS35338-135   | 96906 |         | WASHER (AP) . . . . .   | 9                     |                      | PAFZZ       |
| -6                     | 660147-801    | 37695 |         | CASE, POWER JUNCTION . . . . .                                  | 1                     |                      | XB          |

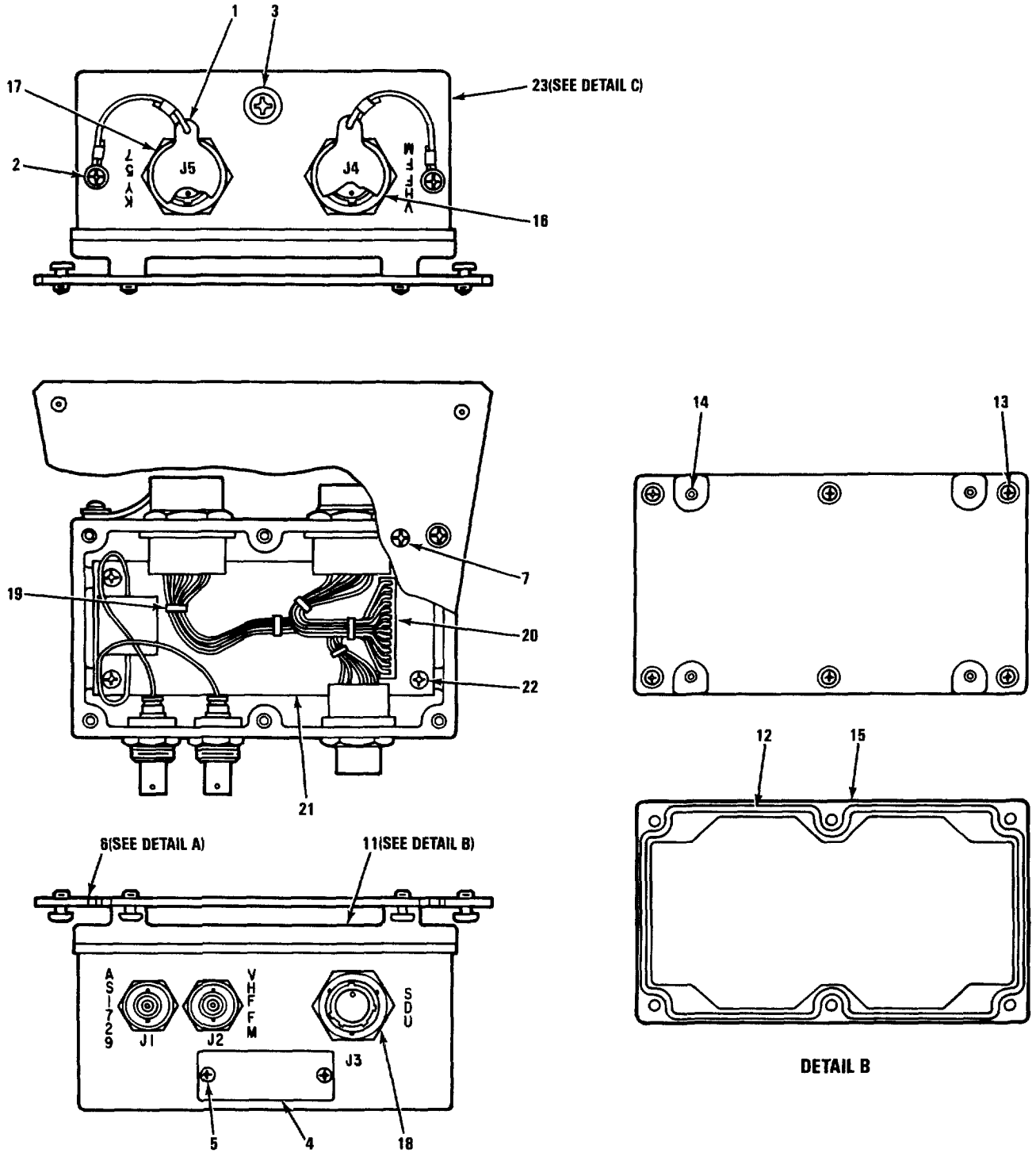

NOTE: REFERENCE DESIGNATIONS ARE ABBREVIATED.  
PREFIX WITH 4A1.

MX-61-119-IPB-26-1  
REF MAG DWG 812132 REV D  
PL 812132 REV R

FIGURE 7-26. FM BITE/AUDIO INTERFACE ASSEMBLY (SHEET 1 OF 2)

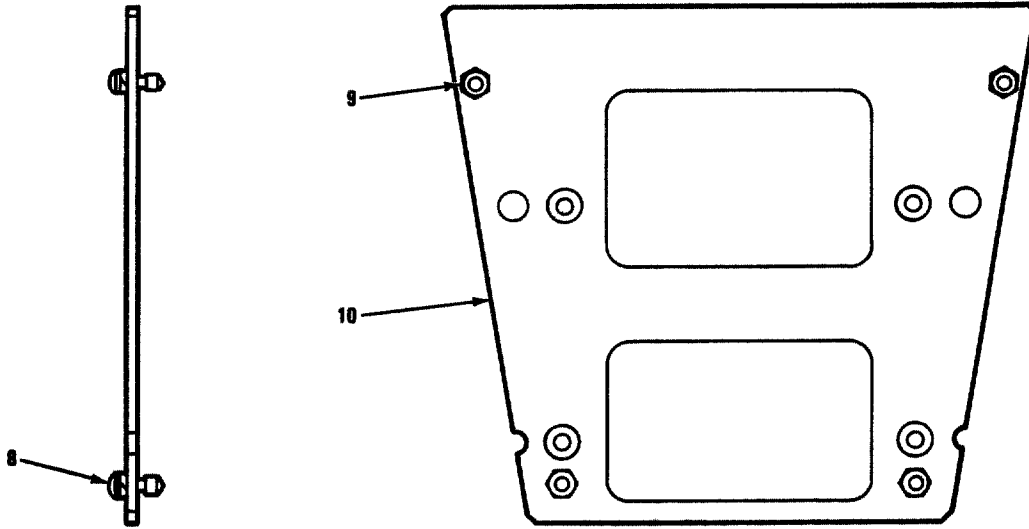

DETAIL A

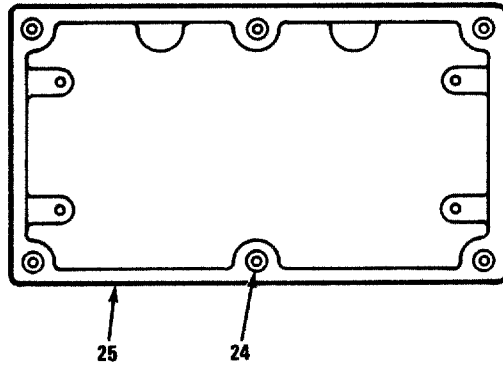

DETAIL C

MX-61-119-IPB-20-2

FIGURE 7-26. FM BITE/AUDIO INTERFACE ASSEMBLY (SHEET 2 OF 2)



| FIG. &<br>INDEX<br>NUMBER | PART NUMBER   | FSCM  | DESCRIPTION  |   |   |   |   |   |   | UNITS<br>PER<br>ASSY | USABLE<br>ON<br>CODE | SMR<br>CODE |
|---------------------------|---------------|-------|--|---|---|---|---|---|---|----------------------|----------------------|-------------|
|                           |               |       | 1  | 2 | 3 | 4 | 5 | 6 | 7 |                      |                      |             |
| 7-26-                     | 812132-801    | 37695 | INTERFACE ASSEMBLY, FM BITE/AUDIO . . . . .<br>(SEE FIGURE 7-24 FOR NHA) |   |   |   |   |   |   | REF                  |                      | PAOLD       |
| -1                        | 812187-804    | 37695 | . CAP ASSEMBLY . . . . .   |   |   |   |   |   |   | 2                    |                      | PAFZZ       |
| -2                        | MS51957-14B   | 96906 | . SCREW (AP) . . . . .   |   |   |   |   |   |   | 2                    |                      | PAFZZ       |
|                           | MS35338-135B  | 96906 | . WASHER (AP) . . . . .  |   |   |   |   |   |   | 2                    |                      | PAFZZ       |
|                           | 514919-1      | 37695 | . RETAINER (AP) . . . . .  |   |   |   |   |   |   | 2                    |                      | PAFZZ       |
| -3                        | MS3213-31     | 96906 | . SCREW . . . . .  |   |   |   |   |   |   | 1                    |                      | PAFZZ       |
| -4                        | 155896-       | 37695 | . PLATE, IDENTIFICATION . . . . .  |   |   |   |   |   |   | 1                    |                      | MDD         |
| -5                        | MS51957-11    | 96906 | . SCREW (AP) . . . . .   |   |   |   |   |   |   | 2                    |                      | PAFZZ       |
| -6                        | 939265-801    | 37695 | . PLATE, MOUNTING. . . . .   |   |   |   |   |   |   | 1                    |                      | XB          |
| -7                        | MS24693C47    | 96906 | . SCREW (AP) . . . . .   |   |   |   |   |   |   | 4                    |                      | PAFZZ       |
| -8                        | 136555-3      | 37695 | . . SCREW, MODIFIED. . . . .   |   |   |   |   |   |   | 4                    |                      | PAFZZ       |
|                           | MS35338-138   | 96906 | . . WASHER . . . . .   |   |   |   |   |   |   | 4                    |                      | PAFZZ       |
| -9                        | M45938/4-9    | 81349 | . . NUT, PLAIN, CLINCH. . . . .  |   |   |   |   |   |   | 4                    |                      | PAFZZ       |
| -10                       | 939265-1      | 37695 | . . PLATE, MOUNTING. . . . .   |   |   |   |   |   |   | 1                    |                      | XA          |
| -11                       | 660177-801    | 37695 | . COVER, FM BITE/AUDIO . . . . .   |   |   |   |   |   |   | 1                    |                      | XB          |
| -12                       | 348294-3      | 37695 | . . GASKET, RUBBER . . . . .   |   |   |   |   |   |   | 1                    |                      | XB          |
| -13                       | 136555-1      | 37695 | . . SCREW . . . . .  |   |   |   |   |   |   | 6                    |                      | PAFZZ       |
|                           | NAS620C6      | 80205 | . . WASHER . . . . .   |   |   |   |   |   |   | 6                    |                      | PAFZZ       |
| -14                       | MS21209C0815L | 96906 | . . INSERT . . . . .   |   |   |   |   |   |   | 4                    |                      | PAFZZ       |
| -15                       | 660177-1      | 37695 | . . COVER, FM BITE/AUDIO . . . . .                                       |   |   |   |   |   |   | 1                    |                      | XA          |
| -16                       | MS3114E14-19P | 96906 | . CONNECTOR . . . . .  |   |   |   |   |   |   | 1                    |                      | PADZZ       |
| -17                       | MS3114E14-19S | 96906 | . CONNECTOR . . . . .  |   |   |   |   |   |   | 1                    |                      | PADZZ       |
| -18                       | MS3114E12-10S | 96906 | . CONNECTOR . . . . .  |   |   |   |   |   |   | 1                    |                      | PADZZ       |
| -19                       | MS3367-4-9    | 96906 | . STRAP, TIEDOWN. . . . .  |   |   |   |   |   |   | 12                   |                      | PADZZ       |
| -20                       | 2-87631-3     | 00779 | . CONNECTOR, RECEPTACLE (MAGNAVOX . . . . .<br>SPEC CONT DWG 185971-5)   |   |   |   |   |   |   | 1                    |                      | PADZZ       |
|                           | 87046-3       | 00779 | . CONTACT, ELECTRICAL (MAGNAVOX SPEC. . . . .<br>CONT DWG 165338-5)      |   |   |   |   |   |   | 27                   |                      | PADZZ       |
|                           | = MS3519/1-3  | 81349 | . SPLICE, CONDUCTOR. . . . .   |   |   |   |   |   |   | 14                   |                      | PADZZ       |
|                           | = NAS1745-3   | 80205 | . SPLICE, CONDUCTOR. . . . .   |   |   |   |   |   |   | 14                   |                      | PADZZ       |
| -21                       | 812424-801    | 37695 | . CIRCUIT CARD ASSEMBLY (SEE . . . . .<br>FIGURE 7-27 FOR BKDN)          |   |   |   |   |   |   | 1                    |                      | PAFLD       |
| -22                       | MS51957-13    | 96906 | . SCREW (AP) . . . . .   |   |   |   |   |   |   | 4                    |                      | PAFZZ       |
|                           | NAS620C4      | 80205 | . WASHER (AP) . . . . .  |   |   |   |   |   |   | 4                    |                      | PAFZZ       |
|                           | MS35338-135   | 96906 | . WASHER (AP) . . . . .  |   |   |   |   |   |   | 4                    |                      | PAFZZ       |
| -23                       | 660159-801    | 37695 | . CASE, FM BITE/AUDIO. . . . .   |   |   |   |   |   |   | 1                    |                      | XB          |
| -24                       | MS122118      | 96906 | . . INSERT . . . . .   |   |   |   |   |   |   | 6                    |                      | PAFZZ       |
| -25                       | 660159-1      | 37695 | . . CASE, VHF BITE/AUDIO . . . . .                                       |   |   |   |   |   |   | 1                    |                      | XA          |

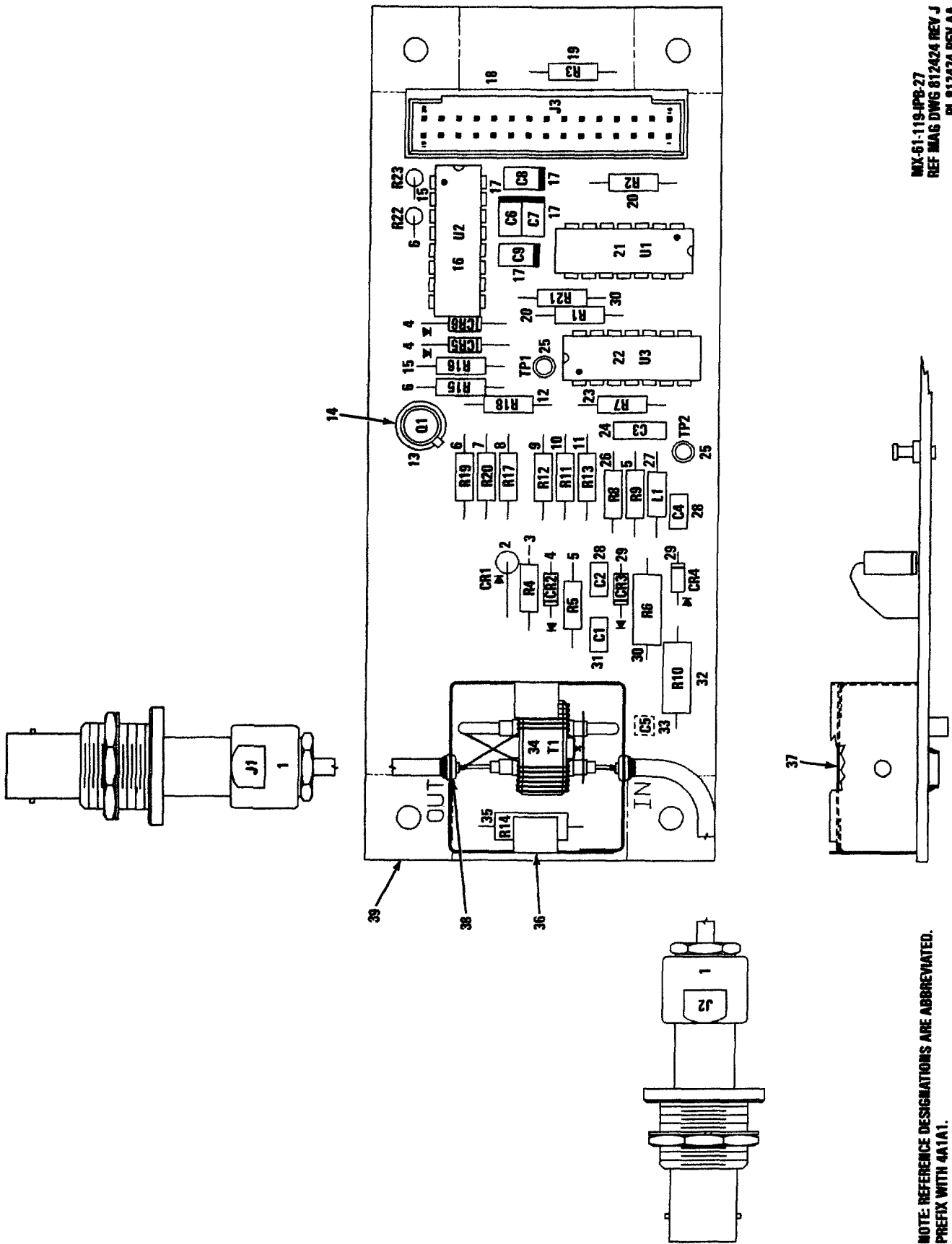

MX-61-119-IPB-27  
 REF MAG DWG 612424 REV J  
 PL 612424 REV AA

FIGURE 7-27. CIRCUIT CARD ASSEMBLY

NOTE: REFERENCE DESIGNATIONS ARE ABBREVIATED.  
 PREFIX WITH 4A1A1.

| FIG. &<br>INDEX<br>NO. | PART NUMBER                  | FSCM<br>1234567 | DESCRIPTION  | UNITS<br>PER<br>ASSY. | USABLE<br>ON<br>CODE | SMR<br>CODE |
|------------------------|------------------------------|-----------------|--|-----------------------|----------------------|-------------|
| 7-27-                  | B12424-B01                   | 37695           | CIRCUIT CARD ASSEMBLY (SEE . . . . . REF<br>FIGURE 7-26 FOR NHA)       |                       |                      | PAFLD       |
| -1                     | K819-B3801-75                | 94375           | CONNECTOR, RECEPTACLE (MAGNAVOX. . .<br>SPEC CONT DWG 189138-7)        | 2                     |                      | PADZZ       |
| -2                     | JANTX1N825-1                 | 81349           | SEMICONDUCTOR DEVICE. . . . .  | 1                     |                      | PADZZ       |
| -3                     | RCR070511JS                  | 81349           | RESISTOR. . . . .  | 1                     |                      | PADZZ       |
| -4                     | JANTX1N4454-1                | 81349           | SEMICONDUCTOR DEVICE. . . . .  | 3                     |                      | PADZZ       |
| -5                     | RCR070162JS                  | 81349           | RESISTOR. . . . .  | 2                     |                      | PADZZ       |
| -6                     | RCR070103JS                  | 81349           | RESISTOR. . . . .  | 3                     |                      | PADZZ       |
| -7                     | RCR070332JS                  | 81349           | RESISTOR. . . . .  | 1                     |                      | PADZZ       |
| -8                     | RCR070102JS                  | 81349           | RESISTOR. . . . .  | 1                     |                      | PADZZ       |
| -9                     | RCR070911JS                  | 81349           | RESISTOR. . . . .  | 1                     |                      | PADZZ       |
| -10                    | RCR070302JS                  | 81349           | RESISTOR. . . . .  | 1                     |                      | PADZZ       |
| -11                    | RCR070183JS                  | 81349           | RESISTOR. . . . .  | 1                     |                      | PADZZ       |
| -12                    | RCR070473JS                  | 81349           | RESISTOR. . . . .  | 1                     |                      | PADZZ       |
| -13                    | JANTX2N2222A                 | 81349           | SEMICONDUCTOR DEVICE. . . . .  | 1                     |                      | PADZZ       |
| -14                    | 7717-43N-BLACK               | 13103           | INSULATOR, TRANSISTOR. . . . .<br>(MAGNAVOX SPEC CONT<br>DWG 447279-8) | 1                     |                      | XB          |
| -15                    | RCR070133JS                  | 81349           | RESISTOR. . . . .  | 2                     |                      | PADZZ       |
| -16                    | 615677-901                   | 37695           | MICROCIRCUIT (ESDS)  | 1                     |                      | PADZZ       |
| -17                    | S106R                        | 17554           | CAPACITOR (MAGNAVOX SPEC. . . . .<br>CONT DWG 275064-96)               | 4                     |                      | PADZZ       |
| -18                    | 5188-157-9                   | 00779           | CONNECTOR, HEADER (MAGNAVOX. . . . .<br>SPEC CONT DWG 185972-4)        | 1                     |                      | PADZZ       |
| -19                    | RCR070122JS                  | 81349           | RESISTOR. . . . .  | 1                     |                      | PADZZ       |
| -20                    | RCR070104JS                  | 81349           | RESISTOR. . . . .  | 1                     |                      | PADZZ       |
| -21                    | 616505-901                   | 37695           | MICROCIRCUIT (ESDS)  | 1                     |                      | PADZZ       |
| -22                    | *JM38510/05252BCX            | 81349           | MICROCIRCUIT (ESDS)  | 1                     |                      | PADZZ       |
| -22                    | 615515-901                   | 37695           | MICROCIRCUIT (ESDS)  | 1                     |                      | PADZZ       |
| -22                    | *JM38510/11005BCX            | 81349           | MICROCIRCUIT (ESDS)  | 1                     |                      | PADZZ       |
| -23                    | RCR070105JS                  | 81349           | RESISTOR. . . . .  | 1                     |                      | PADZZ       |
| -24                    | M39014/02-1419               | 81349           | CAPACITOR . . . . .  | 1                     |                      | PADZZ       |
| -24                    | *M39014/02-1407              | 81349           | CAPACITOR . . . . .  | 1                     |                      | PADZZ       |
| -25                    | SE16XC02                     | 81349           | TERMINAL, STUD . . . . .   | 2                     |                      | PADZZ       |
| -26                    | RCR070622JS                  | 81349           | RESISTOR. . . . .  | 1                     |                      | PADZZ       |
| -27                    | MS75083-13                   | 96906           | COIL. . . . .  | 1                     |                      | PADZZ       |
| -28                    | M39014/01-1351               | 81349           | CAPACITOR . . . . .  | 2                     |                      | PADZZ       |
| -28                    | *M39014/01-1271              | 81349           | CAPACITOR . . . . .  | 2                     |                      | PADZZ       |
| -29                    | 615485-1                     | 37695           | SEMICONDUCTOR DEVICE. . . . .  | 2                     |                      | PADZZ       |
| -30                    | RCR070200JS                  | 81349           | RESISTOR. . . . .  | 1                     |                      | PADZZ       |
| -31                    | M39014/01-1357               | 81349           | CAPACITOR . . . . .  | 1                     |                      | PADZZ       |
| -31                    | *M39014/01-1397              | 81349           | CAPACITOR . . . . .  | 1                     |                      | PADZZ       |
| -32                    | RCR200300JS                  | 81349           | RESISTOR. . . . .  | 1                     |                      | PADZZ       |
| -33                    | ATC-100-B-102-K-<br>P-100-SP | 29990           | CAPACITOR (MAGNAVOX SPEC. . . . .<br>CONT DWG 258300-11185)            | 1                     |                      | PADZZ       |
| -34                    | 368883-810                   | 37695           | TRANSFORMER BALUM . . . . .  | 1                     |                      | PADZZ       |
| -35                    | RCR200510JS                  | 81349           | RESISTOR. . . . .  | 1                     |                      | PADZZ       |
| -36                    | 939053-1                     | 37695           | SHIELD, RF . . . . .   | 1                     |                      | XB          |
| -37                    | 939053-2                     | 37695           | SHIELD, RF . . . . .   | 1                     |                      | XB          |
| -38                    | NAB1788-3-4                  | 80205           | EYELET, METALLIC . . . . .   | 2                     |                      | XB          |
| -39                    | 412080-1                     | 37695           | PRINTED WIRING BOARD. . . . .  | 1                     |                      | XB          |

Section III. NUMERIC INDEX

| PART NUMBER                 | FIG & INDEX NUMBER | PART NUMBER           | FIG & INDEX NUMBER |
|-----------------------------|--------------------|-----------------------|--------------------|
| AM25L8299DMG                | 7-6-17             | JANTX1N5616           | 7-19-2             |
| AN960C4                     | F7-14-13           | JANTX1N5618           | 7-11-6             |
| AS-1729/VRC                 | 7-1-6              | JANTX1N5651A          | 7-14-7             |
| AS-3988/QRC-206             | 7-1-3              | JANTX1N5711           | 7-11-49            |
| AS2259/QR                   | 7-1-2              | JANTX1N5968           | 7-11-12            |
| ATC-100-B-102-K-P-100-8P    | 7-27-33            | JANTX1N6092           | F7-20-4            |
| BP30-2-BR                   | 7-15-14            | JANTX1N647-1          | 7-7-1              |
| CA110821-10                 | 7-22-18            | JANTX1N751A1          | 7-11-20            |
| CA111349                    | 7-15-28            | JANTX1N752A1          | 7-6-1              |
| CA111384                    | 7-25-3             | JANTX1N825-1          | 7-27-2             |
| CA121003-2                  | 7-15-1             | JANTX1N967B           | F7-9-70            |
| CA121003-9                  | 7-15-24            | JANTX1N973B1          | 7-4-11             |
| CA29040-06-3-5P             | 7-14-23            | JANTX2N2222A          | 7-9-68             |
| CA3102E128-388              | 7-15-3             | JANTX2N2905A          | 7-5-40             |
| CA3102E24-22PB              | 7-15-25            | JANTX2N2907A          | 7-4-22             |
| CD40168MJ/8838              | 7-19-75            | JANTX2N3029           | 7-9-14             |
|                             | 7-20-37            | JANTX2N3467           | 7-19-88            |
| CD4508BD/3                  | F7-4-49            | JANTX2N3868           | 7-7-3              |
|                             | F7-5-26            | JANTX2N629B           | 7-19-3             |
|                             | F7-20-53           | JAN1N1614             | 7-14-19            |
| CM43842-4                   | 7-18-8             | JM38510/05051BCX      | F7-4-41            |
| CM43842-7                   | 7-18-18            | JM38510/05151BCX      | F7-4-37            |
| D-136-05                    | 7-12-19            | JM38510/05252BCX      | F7-27-21           |
| D-144-34                    | 7-12-12            | JM38510/05553BEX      | F7-4-42            |
| D02-046C-A3FB/900-MIL       | F7-1-37            | JM38510/05753BEX      | F7-4-40            |
|                             | F7-1-46            | JM38510/05754BEX      | F7-20-52           |
|                             | F7-1-41            | JM38510/05851BCX      | F7-19-24           |
| D4-12BCAD PLATE IRID YELLOW | F7-12-16           | JM38510/1030480X      | F7-11-54           |
| FOMC-T-05-1245              | F7-1-49            | JM38510/11005BCX      | F7-27-22           |
| FOMC-T-05-1219              | 7-1-39             | JM38510/11201BCX      | F7-4-27            |
|                             | 7-1-43             |                       |                    |
|                             | 7-1-49             |                       |                    |
| FOMC-T-05-1245              | F7-1-39            | JM38510/11402B0X      | 7-11-41            |
|                             |                    | JM38510/11704BYX      | F7-9-37            |
|                             | F7-1-43            | JM38510/12601BEX      | 7-9-55             |
| FOMC-T-05-1270              | F7-1-39            | JM38510/17001BCX      | F7-20-20           |
|                             | F7-1-43            | JM38510/17203BCX      | F7-20-23           |
|                             | F7-1-49            | JM38510/17301BJX      | F7-5-28            |
| FOMC-T-05-1295              | F7-1-39            | JM38510/17305BEX      | F7-20-36           |
|                             | F7-1-43            | JM38510/17505BEX      | F7-20-26           |
|                             | F7-1-49            | JM38510/17602BJX      | F7-4-49            |
| FOMC6-2W2A-001              | 7-1-38             | JM38510/23802BVX      | F7-8-4             |
|                             | 7-1-42             |                       |                    |
|                             | 7-1-48             | JM38510/30001BCX      | F7-8-1             |
|                             |                    | JM38510/30701BEX      | F7-6-11            |
| FOMC7-2W1P-001              | 7-11-1             | JM38510/32001BCX      | F7-7-18            |
| FT-940-DUTR                 | 7-22-20            | JM38510/32002BCX      | F7-7-16            |
| QC-283                      | 7-12-11            | JM38510/32403BRX      | F7-8-26            |
| H-301-6                     | 7-22-5             | JM38510/32502BRX      | F7-8-20            |
| HDJ-24-198 AB               | 7-25-4             | JM38510/32803BRX      | F7-7-23            |
| HYP-57/TSEC                 | 7-1-9              | K819-83801-75         | 7-27-1             |
| H9955-88-2-R0-1200          | 7-24-133           | LB6682                | 7-19-4             |
| JANTX1N4454-1               | 7-4-13             | LC369D2               | 7-15-10            |
| JANTX1N4458-1               | 7-11-42            |                       |                    |
| JANTX1N4465                 | 7-9-48             | LC36YD2               | 7-15-13            |
|                             |                    | LH89/1                | 7-15-12            |
| JANTX1N4471                 | 7-9-70             | LL209R                | F7-20-4            |
| JANTX1N4472                 | 7-9-47             | MR13W050DCVVR         | 7-15-22            |
| JANTX1N4478                 | 7-14-8             | MS1B-1500DHMSFORM1PCT | 7-7-2              |
| JANTX1N4954                 | 7-9-13             |                       |                    |
| JANTX1N5615                 | 7-9-9              |                       |                    |

| PART NUMBER   | FIG &<br>INDEX<br>NUMBER | PART NUMBER     | FIG &<br>INDEX<br>NUMBER |
|---------------|--------------------------|-----------------|--------------------------|
| MS122078      | 7-12-28                  | MS3181-10R      | 7-12-3                   |
| MS122085      | 7-24-138                 | MS3213-31       | 7-2-3                    |
| MS122116      | 7-12-29                  | MS3213-35       | 7-15-33                  |
| MS122118      | 7-12-27                  | MS3213-4        | 7-22-27                  |
| MS122119      | 7-22-36                  | MS3367-1-0      | 7-13-14                  |
| MS15795-B02   | F7-4-46                  | MS3367-4-9      | 7-13-13                  |
| MS15795-B10   | F7-24-50                 | MS35307-334     | 7-24-128                 |
| MS16535-12    | 7-11-52                  | MS35307-341     | 7-24-39                  |
| MS16535-133   | 7-9-4                    | MS35308-303     | 7-24-47                  |
| MS16535-64    | 7-11-25                  | MS35308-306     | 7-24-114                 |
| MS16562-190   | 7-12-30                  | MS35308-332     | 7-24-125                 |
| MS16995-26B   | 7-12-2                   | MS35333-72      | 7-13-16                  |
| MS16995-49    | 7-24-131                 | MS35335-58      | 7-14-24                  |
| MS171496      | 7-24-41                  | MS35338-134     | F7-4-46                  |
| MS17830-5C    | F7-24-39                 | MS35338-135     | F7-2-19                  |
| MS20426AD3-6  | 7-24-83                  | MS35338-135B    | F7-2-5                   |
| MS20426AD3-8  | 7-24-85                  | MS35338-136     | F7-9-25                  |
| MS20426AD4-8  | 7-24-136                 | MS35338-137     | F7-24-109                |
| MS20426AD6-10 | 7-24-59                  | MS35338-138     | F7-24-31                 |
| MS20470AD4-6  | 7-22-33                  | MS35338-139     | F7-24-47                 |
| MS20470A6-8   | 7-22-35                  | MS39087-4       | 7-24-93                  |
| MS20470A6-9   | 7-24-134                 | MS51844-21      | 7-24-5                   |
| MS21044C08    | F7-24-44                 | MS51957-11      | 7-2-2                    |
| MS21044C3     | F7-14-2                  | MS51957-13      | 7-9-28                   |
| MS21044C5     | F7-24-55                 | MS51957-13B     | 7-22-4                   |
| MS21076L08    | 7-24-82                  | MS51957-14B     | 7-2-5                    |
| MS21076L3     | 7-24-84                  | MS51957-15      | 7-2-19                   |
| MS21076L5     | 7-24-135                 | MS51957-15B     | 7-15-4                   |
| MS21209C0615L | 7-22-38                  | MS51957-16      | 7-9-21                   |
| MS21209C0815L | 7-22-39                  | MS51957-17B     | 7-18-17                  |
| MS21333-73    | 7-24-32                  | MS51957-18      | 7-9-24                   |
| MS21333-89    | 7-14-3                   | MS51957-18B     | 7-15-23                  |
| MS24187D2     | 7-14-1                   | MS51957-2       | 7-11-4                   |
| MS24665-151   | 7-24-50                  | MS51957-21      | 7-14-13                  |
| MS24693C1     | 7-24-97                  | MS51957-26      | 7-22-17                  |
| MS24693C26    | 7-24-64                  | MS51957-26B     | 7-15-20                  |
| MS24693C269   | 7-24-94                  | MS51957-27      | 7-12-23                  |
| MS24693C279   | 7-24-80                  | MS51957-27B     | F7-22-4                  |
| MS24693C3     | 7-24-52                  | MS51957-28B     | 7-22-2                   |
| MS24693C47    | 7-26-7                   | MS51957-29      | 7-19-5                   |
| MS24693C49    | 7-24-81                  | MS51957-29B     | 7-15-26                  |
| MS24693C51    | 7-24-44                  | MS51957-30      | 7-20-68                  |
| MS25036-102   | 7-13-11                  | MS51957-4       | 7-4-46                   |
| MS25036-103   | 7-13-10                  | MS51957-43      | 7-24-109                 |
| MS25036-107   | 7-13-12                  | MS51957-45      | 7-24-68                  |
| MS25036-108   | 7-13-7                   | MS51957-46      | 7-24-45                  |
| MS25036-153   | 7-13-15                  | MS51957-46B     | 7-22-6                   |
| MS25082-21    | 7-24-90                  | MS51958-61      | 7-13-9                   |
| MS25082C11    | 7-24-28                  | MS51958-62      | 7-14-2                   |
| MS25237-387   | 7-15-11                  | MS51958-64      | 7-24-35                  |
| MS27719-23    | 7-18-3                   | MS51958-65      | 7-24-88                  |
| MS3112E12-3S  | 7-15-6                   | MS51958-69      | 7-24-33                  |
| MS3114E10-6P  | 7-22-10                  | MS51959-2       | 7-21-2                   |
| MS3114E10-6S  | 7-12-4                   | MS75083-13      | 7-27-27                  |
| MS3114E12-10S | 7-26-18                  | MS75085-19      | 7-4-34                   |
| MS3474W12-3P  | 7-12-7                   | MS75085-7       | 7-4-38                   |
| MS3114E14-19P | 7-26-16                  | MS75089-1       | F7-4-31                  |
| MS3114E14-19S | 7-26-17                  | MS77068-1       | 7-9-40                   |
| MS3114E16-26S | 7-12-6                   | MS77068-2       | 7-12-22                  |
| MS3114E18-32S | 7-12-5                   | MS77068-4       | 7-13-6                   |
| MS3180-12C    | F7-24-6                  | MS91525-OAW3SBZ | 7-15-19                  |
| MS3180-14C    | 7-24-6                   | MS91528-OE1B    | 7-18-6                   |
| MS3180-16C    | F7-24-6                  | MS91528-1E1B    | 7-18-9                   |

| PART NUMBER     | FIG & INDEX NUMBER | PART NUMBER     | FIG & INDEX NUMBER |
|-----------------|--------------------|-----------------|--------------------|
| MT4027          | 7-15-29            | M39014/01-1575  | 7-4-7              |
| MX9313/GR       | 7-1-1              | M39014/01-1587  | 7-19-62            |
| M24066/2-213    | 7-19-42            | M39014/01-1593  | 7-4-5              |
| 209452-1        | 7-11-35            | M39014/02-1218  | F7-9-17            |
| M24066/2-308    | 7-11-24            | M39014/02-1230  | F7-9-12            |
| M25081C4        | 7-18-5             | M39014/02-1234  | F7-4-44            |
| M28748/7B0051A  | 7-18-21            | M39014/02-1350  | 7-9-12             |
| M3840101M20026A | 7-19-64            | M39014/02-1354  | 7-4-44             |
| M3840108K1003JC | 7-20-25            | M39014/02-1388  | 7-9-17             |
| M38510/05851BCB | F7-19-24           | M39014/02-1403  | F7-11-5            |
| M38510/11201BCB | F7-4-27            | M39014/02-1407  | F7-4-4             |
| M38510/17203BCB | F7-20-23           | M39014/02-1419  | 7-4-4              |
| M38510/17301BJB | F7-5-28            | M39018/01-0653  | F7-9-30            |
| M38510/21802BRB | F7-7-23            | M39018/01-0655  | 7-9-30             |
| M38510/30001BCB | F7-8-1             | M39019/01-218   | 7-24-62            |
| M38510/30003BCB | F7-8-19            | M39019/01-230   | 7-12-8             |
| M38510/30701BEB | F7-6-11            | M39019/01-248   | 7-15-9             |
| M38510/32002BCB | F7-7-16            | M45938/4-10     | 7-24-137           |
| M38510/32403BRB | F7-8-26            | M45938/4-3      | 7-24-101           |
| M38510/32502BRB | F7-8-20            | M45938/4-9      | 7-26-9             |
| M38527/02D      | 7-19-45            | M45938/5-4C     | 7-14-21            |
| M38527/2-05     | 7-5-51             | M45938/5-6C     | 7-24-65            |
| M38527/3-01N    | 7-4-23             | M45938/5-7C     | 7-24-76            |
| M38527/3-02N    | 7-11-18            | M45938/5-8C     | 7-14-22            |
| M38527/5-02D    | 7-4-24             | M5423/16-01     | 7-18-4             |
| M39003/01-2116  | F7-9-51            | M55302/110-10   | 7-9-64             |
| M39003/01-2285  | F7-9-67            | M55302/110-13   | 7-4-45             |
| M39003/01-2286  | F7-4-48            | M55302/110-16   | 7-6-19             |
| M39003/01-2304  | F7-9-66            | M55302/27-91    | 7-10-1             |
| M39003/01-2356  | F7-8-11            | M55302/27-94    | 7-10-5             |
| M39003/01-3005  | 7-9-67             | M55302/27-97    | 7-10-3             |
| M39003/01-3006  | 7-4-48             | M55302/7-04     | 7-10-7             |
| M39003/01-3024  | 7-9-66             | M55302/8-04     | 7-12-18            |
| M39003/01-3076  | 7-8-11             | M8340101M36026A | 7-19-26            |
| M39003/03-0184  | F7-19-83           | M8340102M10026B | 7-6-6              |
| M39003/03-0258  | F7-20-30           | M8340105K10026C | 7-5-19             |
| M39003/03-0358  | 7-20-30            | M8340105K10036C | 7-4-47             |
| M39003/03-0384  | 7-19-83            | M8340105K12036C | 7-19-35            |
| M39010/3A150KP  | 7-4-31             | M8340105M10036C | 7-19-25            |
| M39012/01-0005  | 7-1-19             | M8340105M68026C | 7-19-27            |
| M39012/05-0101  | 7-1-20             | M83461/1-017    | 7-24-27            |
| M39012/06-0002  | 7-1-25             | M83461/1-116    | 7-22-30            |
| M39012/16-0101  | 7-1-31             | M83505/6-001    | 7-20-2             |
| M39012/20-0101  | 7-1-32             | M83519/1-3      | F7-26-20           |
| M39014/01-1221  | F7-19-52           | NAS1397R5B      | 7-12-15            |
| M39014/01-1227  | 7-19-8             | NAS1745-3       | F7-26-20           |
| M39014/01-1231  | F7-9-53            | NAS1788-3-4     | 7-27-38            |
| M39014/01-1233  | F7-19-47           | NAS620C10       | 7-14-16            |
| M39014/01-1237  | F7-4-6             | NAS620C2        | F7-10-2            |
| M39014/01-1271  | F7-20-28           | NAS620C4        | F7-2-19            |
| M39014/01-1341  | 7-19-52            | NAS620C416      | 7-24-100           |
| M39014/01-1351  | 7-9-53             | NAS620C5L       | F7-12-21           |
| M39014/01-1353  | 7-19-47            | NAS620C6        | 7-3-7              |
| M39014/01-1357  | 7-4-6              | NAS620CB        | F7-18-2            |
| M39014/01-1397  | F7-27-31           | NAS671C10       | 7-14-14            |
| M39014/01-1433  | F7-11-40           | NAS671C2        | F7-4-46            |
| M39014/01-1442  | F7-19-28           | NAS671C4        | F7-9-38            |
| M39014/01-1451  | F7-9-56            | NAS671C6        | F7-12-23           |
| M39014/01-1455  | F7-4-7             | PB2-65          | 7-20-44            |
| M39014/01-1467  | F7-19-62           | PIC0-2996       | 7-4-2              |
| M39014/01-1473  | F7-4-5             | PIC0-3776       | 7-19-61            |
| M39014/01-1562  | 7-19-28            | PVJ7B14B19MSNN  | 7-12-10            |
| M39014/01-1574  | 7-9-56             | RCR0561003GR    | 7-11-38            |

| PART NUMBER | FIG & INDEX NUMBER | PART NUMBER   | FIG & INDEX NUMBER |
|-------------|--------------------|---------------|--------------------|
| RCR050101JB | 7-11-10            | RCR070752JS   | 7-7-20             |
| RCR050102JB | 7-4-9              | RCR070822JS   | 7-9-1              |
| RCR050103JB | 7-4-16             | RCR070911JS   | 7-27-9             |
| RCR050104JB | 7-4-3              | RCR200270JS   | 7-5-49             |
| RCR050105JB | 7-5-25             | RCR200300JS   | 7-11-9             |
| RCR050113JB | 7-19-30            | RCR200330JS   | 7-11-15            |
| RCR050151JB | 7-19-20            | RCR200391JS   | 7-5-52             |
| RCR050155JB | 7-4-43             | RCR200432JS   | 7-20-24            |
| RCR050163JB | 7-5-37             | RCR200510JS   | 7-27-35            |
| RCR0502R7JB | 7-19-9             | RCR320181JS   | 7-4-1              |
| RCR050202JB | 7-4-25             | RCR320222JS   | 7-13-5             |
| RCR050222JB | 7-11-36            | RCR320390JS   | 7-5-43             |
| RCR050242JB | 7-4-28             | RCR3205R6JS   | 7-5-42             |
| RCR050272JB | 7-5-22             | RCR320511JS   | 7-9-36             |
| RCR050273JB | 7-5-20             | RCR320751JS   | 7-9-26             |
| RCR050303JB | 7-11-48            | RLR05C1001QR  | 7-11-44            |
| RCR050332JB | 7-4-12             | RLR05C3302QR  | 7-11-43            |
| RCR050333JB | 7-4-15             | RNC50H3322FR  | 7-20-10            |
| RCR050393JB | 7-4-18             | RNC50H6981FM  | 7-20-9             |
| RCR050394JB | 7-19-70            | RNC50JS5492BS | 7-20-19            |
| RCR050471JB | 7-19-60            | RNC55H1002FM  | 7-9-63             |
| RCR050472JB | 7-19-51            | RNC55H1182FM  | F7-9-44            |
| RCR050473JB | 7-5-38             | RNC55H1212FM  | F7-9-44            |
| RCR050512JB | 7-19-57            | RNC55H1242FM  | F7-9-44            |
| RCR050513JB | 7-4-8              | RNC55H1272    | F7-9-44            |
| RCR050514JB | 7-5-21             | RNC55H1302FM  | F7-9-44            |
| RCR050562JB | 7-4-26             | RNC55H1332FM  | F7-9-44            |
| RCR050624JB | 7-19-73            | RNC55H1372FM  | 7-9-44             |
| RCR050682JB | 7-4-17             | RNC55H1402FM  | F7-9-44            |
| RCR050753JB | 7-19-53            | RNC55H1432FM  | F7-9-44            |
| RCR050754JB | 7-19-50            | RNC55H1472FM  | F7-9-44            |
| RCR050822JB | 7-5-17             | RNC55H1502FM  | F7-9-44            |
| RCR070100JS | 7-9-32             | RNC55H1542FM  | F7-9-44            |
| RCR070101JS | 7-9-11             | RNC55H2001FM  | 7-9-45             |
| RCR070102JS | 7-5-45             | RNC55H2430FM  | 7-9-42             |
| RCR070103JS | 7-5-44             | RNC55H2432FM  | 7-9-62             |
| RCR070104JS | 7-7-21             | RNC55H2491FM  | 7-9-43             |
| RCR070105JS | 7-6-3              | RNC55H3011FM  | 7-9-59             |
| RCR070122JS | 7-27-19            | RNC55H4991FM  | 7-9-58             |
| RCR070123JS | 7-9-49             | RNC55H5111FM  | 7-9-61             |
| RCR070133JS | 7-27-15            | RNC55H5621FM  | 7-9-57             |
| RCR070162JS | 7-27-5             | RNC55H5761FM  | F7-9-46            |
| RCR070183JS | 7-27-11            | RNC55H5901FM  | F7-9-46            |
| RCR070200JS | 7-27-30            | RNC55H6041FM  | F7-9-46            |
| RCR070202JS | 7-6-14             | RNC55H6191FM  | 7-9-46             |
| RCR070203JS | 7-7-14             | RNC55H6341FM  | F7-9-46            |
| RCR070204JS | 7-9-54             | RNC55H6491FM  | F7-9-46            |
| RCR070243JS | 7-8-6              | RNC55H6651FM  | F7-9-46            |
| RCR070244JS | 7-9-10             | RNC55H6811FM  | F7-9-46            |
| RCR070301JS | 7-11-19            | RNC55H6981FM  | F7-9-46            |
| RCR070302JS | 7-6-13             | RNC55H7151FM  | F7-9-46            |
| RCR070304JS | 7-9-60             | RNC55H7321FM  | F7-9-46            |
| RCR070332JS | 7-9-31             | RNC65J1021BS  | 7-20-21            |
| RCR070392JS | 7-8-5              | RNC65J1041BS  | F7-20-21           |
| RCR070393JS | 7-6-2              | RNC65J1051BS  | F7-20-21           |
| RCR070432JS | 7-9-34             | RNC65J1061BS  | F7-20-21           |
| RCR070471JS | 7-8-22             | RNC65J1071BS  | F7-20-21           |
| RCR070472JS | 7-7-17             | RNC65J1091BS  | F7-20-21           |
| RCR070473JS | 7-27-12            | RNC65J1101BS  | F7-20-21           |
| RCR070511JS | 7-27-3             | RNC65J1111BS  | F7-20-21           |
| RCR070514JS | 7-8-8              | RNC65J1131BS  | F7-20-21           |
| RCR070622JS | 7-27-26            | RNC65J1141BS  | F7-20-21           |
| RCR070623JS | 7-6-7              | RNC65J1151BS  | F7-20-21           |

| PART NUMBER                  | FIG & INDEX NUMBER | PART NUMBER       | FIG & INDEX NUMBER |
|------------------------------|--------------------|-------------------|--------------------|
| RNC65J1171BS                 | F7-20-21           | 136556-1          | 7-12-26            |
| RNC65J1181BS                 | F7-20-21           | 136583-2          | 7-24-130           |
| RT-246/VRC                   | 7-1-7              | 136597-3          | 7-19-1             |
| RT-524/VRC                   | F7-1-7             |                   | 7-23-1             |
| RV65AYSA103C                 | 7-18-7             | 136602-1          | F7-19-1            |
| RWR808R200FM                 | 7-9-35             | 136602-4          | 7-23-2             |
| RWR808R243FM                 | 7-9-15             | 136617-3          | 7-24-1             |
| RWR8081501FM                 | 7-9-18             | 136652-1          | 7-11-2             |
| RWR8082001FM                 | 7-9-2              | 15R1-1AC          | 7-24-89            |
| RWR8082741FM                 | 7-9-69             | 158-11-2AE        | 7-24-92            |
| RWRB181R27FR                 | 7-23-6             | 1581-3-1AC        | 7-24-91            |
| RWRB181R69FR                 | F7-23-5            | 155896-           | 7-2-1              |
| RWRB181R69FB                 | 7-23-5             |                   | 7-13-1             |
| RWRB181001BR                 | 7-20-17            |                   | 7-17-1             |
| RWRB181001FR                 | 7-19-15            |                   | 7-24-36            |
| RWRB1816R2FR                 | 7-11-26            |                   | 7-26-4             |
| RWRB186190FR                 | 7-20-49            | 155931-1          | 7-1-44             |
| RWRB9842R2FR                 | 7-4-30             | 155931-13         | 7-1-34             |
| S-203                        | 7-4-32             | 155931-14         | 7-1-35             |
|                              | 7-5-30             | 155931-15         | 7-1-23             |
|                              | 7-6-15             | 155931-16         | 7-1-22             |
|                              | 7-7-15             | 155931-17         | 7-1-29             |
|                              | 7-8-16             | 155931-18         | 7-1-28             |
|                              | 7-9-22             | 155931-2          | 7-1-40             |
| SC-B-83314-2CE-D. D. -STRIKE | 7-22-3             | 155931-3          | 7-1-51             |
| SE16XC018                    | 7-6-8              | 155931-4          | 7-1-17             |
| SE16XC02                     | 7-27-25            | 155931-5          | 7-1-21             |
| SE20XD01                     | 7-12-17            | 155931-6          | 7-1-27             |
| SS10R180                     | 7-24-99            | 155931-7          | 7-1-33             |
| S106R                        | 7-27-17            | 155931-9          | 7-22-14            |
| TSEC/KY57                    | 7-1-8              | 156014-1          | 7-15-34            |
| TSEC/KY65                    | 7-1-10             | 156014-2          | 7-15-35            |
| T113-4 MHZ                   | 7-8-28             | 156014-3          | 7-15-36            |
| T213-3.2 MHZ                 | 7-4-39             | 156014-4          | 7-24-29            |
|                              | 7-19-76            | 186095-1          | 7-19-37            |
| T44-AB-10                    | 7-24-46            |                   | 7-20-12            |
|                              | 7-24-113           | 186095-10         | 7-5-27             |
| UPON66-8251-1                | 7-15-17            | 186095-2          | 7-20-1             |
| Z-AKF/TSEC                   | 7-1-11             | 186095-5          | 7-5-18             |
| 1-87631-1                    | 7-22-25            |                   | 7-20-55            |
| 100-300-12-B                 | 7-9-3              | 186095-7          | 7-20-33            |
| 101X792U075CB2A              | 7-14-6             | 186095-8          | 7-4-21             |
| 102241-3                     | 7-18-22            |                   | 7-5-48             |
| 10398-N                      | 7-19-14            |                   | 7-20-61            |
|                              | 7-23-10            | 186161-2          | F7-22-18           |
| 107240-30                    | F7-9-38            | 186163-3          | 7-20-71            |
|                              | F7-9-39            | 186163-5          | 7-20-74            |
| 107240-40                    | 7-11-7             | 186749-1          | 7-22-9             |
| 109429-3                     | 7-14-17            | 186767-1          | 7-11-22            |
| 128324-1                     | 7-22-34            | 2-87631-2         | 7-12-13            |
| 128333-1                     | 7-22-32            |                   | 7-18-24            |
| 136279-1                     | 7-25-2             |                   | 7-22-21            |
| 136279-3                     | F7-24-122          | 2-87631-3         | 7-26-20            |
| 136279-4                     | F7-24-55           | 209452-1          | 7-11-35            |
| 136539-1                     | 7-24-49            | 2257R             | 7-23-16            |
|                              | 7-24-69            | 275056-3242       | 7-11-37            |
|                              | 7-24-117           |                   | 7-19-12            |
| 136555-1                     | 7-3-6              |                   | 7-20-51            |
|                              | 7-9-25             | 324043            | 7-13-8             |
|                              | 7-24-104           | 325322-1          | 7-9-27             |
|                              | 7-26-13            | 325323-1          | 7-9-19             |
| 136555-2                     | 7-18-2             | 325324-1          | 7-9-71             |
| 136555-3                     | 7-26-8             | 34280L561T050RMA3 | 7-9-5              |



| PART NUMBER       | FIGURE AND INDEX NUMBER | PART NUMBER | FIGURE AND INDEX NUMBER |
|-------------------|-------------------------|-------------|-------------------------|
| 3428QL721V050RMA3 | 7-9-29                  | 5-15611-469 | 7-15-21                 |
| 348205-2          | 7-2-8                   | 5-16421-4   | 7-18-15                 |
| 348205-6          | 7-24-4                  | 514816-1    | 7-24-139                |
| 348240-1          | 7-20-69                 | 514816-801  | 7-24-132                |
| 348253-1          | 7-21-3                  | 514825-1    | 7-20-70                 |
| 348253-2          | 7-21-4                  | 514863-1    | 7-24-53                 |
| 348293-1          | 7-15-15                 |             | 7-24-72                 |
| 348294-1          | 7-3-2                   |             |                         |
| 348294-2          | 7-21-11                 | 514891-1    | 7-12-1                  |
| 348294-3          | 7-26-12                 | 514891-1    | 7-15-37                 |
|                   |                         | 514892-1    | 7-12-31                 |
| 348294-4          | 7-3-1                   |             | 7-15-41                 |
| 348297-10         | 7-22-28                 | 514900-801  | 7-22-1                  |
| 348297-13         | 7-14-5                  | 514919-1    | 7-2-4                   |
| 348297-14         | 7-3-4                   |             | F7-26-2                 |
| 348297-15         | 7-3-3                   | 514993-1    | 7-24-26                 |
| 348297-2          | 7-22-31                 | 515166-1    | 7-24-38                 |
| 348297-3          | 7-3-5                   | 515167-1    | 7-24-42                 |
| 348297-9          | 7-24-95                 | 515167-801  | 7-24-40                 |
| 348403-1          | 7-24-106                | 515168-1    | 7-24-115                |
| 348403-3          | 7-21-8                  |             |                         |
|                   |                         | 515357-1    | 7-24-119                |
| 348494-1          | 7-1-47                  | 515368-1    | 7-11-56                 |
| 348499-1          | 7-1-16                  | 515618-1    | 7-24-54                 |
| 348559-1          | 7-8-29                  | 5188-101-18 | 7-4-29                  |
|                   | 7-19-89                 | 5188-157-11 | 7-4-14                  |
| 348625-1          | 7-19-6                  |             | 7-23-4                  |
| 348657-1          | 7-1-58                  | 5188-157-9  | 7-27-18                 |
| 348763-1          | 7-24-74                 | 5188-244-2  | 7-11-8                  |
| 348894-1          | 7-20-5                  |             | 7-19-40                 |
| 349066-1          | 7-24-34                 | 5188-244-3  | 7-19-84                 |
| 349066-2          | F7-24-33                | 5188-244-4  | 7-19-59                 |
| 349153-1          | 7-22-7                  | 5188-244-5  | 7-19-82                 |
|                   |                         |             |                         |
| 349217-1          | 7-21-5                  | 5188-466-8  | 7-20-64                 |
| 349217-2          | 7-21-6                  | 5188-590-12 | 7-19-72                 |
| 349217-3          | 7-21-7                  | 5210-128-11 | 7-20-40                 |
| 349850-1          | F7-22-6                 | 5220-11-9   | 7-11-34                 |
| 368883-810        | 7-27-34                 | 553-6725-00 | 7-1-5                   |
| 405018-2          | 7-1-50                  | 566073-801  | 7-1-12                  |
| 412039-1          | 7-4-50                  | 566073-802  | 7-1-13                  |
| 412040-1          | 7-5-53                  | 566076-801  | 7-1-15                  |
| 412041-1          | 7-8-30                  | 566077-801  | 7-1-18                  |
| 412042-1          | 7-7-31                  | 566077-802  | 7-1-24                  |
|                   |                         |             |                         |
| 412043-1          | 7-9-75                  | 566078-801  | 7-1-30                  |
| 412044-1          | 7-6-22                  | 566078-802  | 7-24-20                 |
| 412045-1          | 7-20-75                 | 566080-801  | 7-1-41                  |
| 412050-1          | 7-19-90                 | 566081-801  | 7-1-45                  |
| 412051-1          | 7-10-8                  | 566083-801  | 7-24-13                 |
| 412080-1          | 7-27-39                 | 566083-802  | 7-24-17                 |
| 412274-1          | 7-23-18                 | 566083-803  | 7-24-19                 |
| 412647-1          | 7-11-27                 | 566083-804  | 7-24-24                 |
| 412648-1          | 7-11-55                 | 566083-805  | 7-24-25                 |
| 435656-1          | 7-12-25                 | 566083-806  | 7-1-36                  |
|                   |                         |             |                         |
| 435664-1          | 7-9-20                  | 566084-801  | 7-24-14                 |
| 435690-1          | 7-20-45                 | 566084-802  | 7-24-16                 |
| 446731-2          | 7-14-18                 | 566084-803  | 7-24-23                 |
| 499914-1          | 7-17-6                  | 566084-804  | 7-24-15                 |

**T.O. 31R2-2GRC206-12**

| PART NUMBER     | FIGURE AND INDEX NUMBER | PART NUMBER | FIGURE AND INDEX NUMBER |
|-----------------|-------------------------|-------------|-------------------------|
| 566084-805      | 7-24-18                 | 616492-901  | 7-19-65                 |
| 566084-806      | 7-16-2                  |             | 7-20-31                 |
| 566084-807      | 7-1-37                  |             | 7-20-41                 |
| 566085-801      | 7-24-7                  | 616492-903  | 7-20-62                 |
| 566085-802      | 7-24-8                  | 616497-903  | 7-14-12                 |
| 566085-803      | 7-24-9                  | 616501-901  | 7-4-37                  |
|                 |                         |             | 7-5-39                  |
| 566085-804      | 7-24-10                 |             | 7-19-79                 |
| 566085-805      | 7-24-11                 | 616504-901  | 7-20-23                 |
| 566085-806      | 7-24-12                 |             |                         |
| 566085-807      | 7-1-14                  | 616505-901  | 7-27-21                 |
| 566588-801      | 7-2-11                  | 616506-901  | 7-4-42                  |
| 566613-801      | 7-22-11                 |             | 7-19-78                 |
| 60-11-4305-1674 | 7-9-41                  |             | 7-20-57                 |
| 6007            | 7-19-87                 | 616521-901  | 7-20-52                 |
| 615279-901      | 7-6-11                  | 616521-902  | 7-4-40                  |
|                 | 7-8-2                   |             | 7-5-32                  |
| 615331-901      | 7-8-19                  |             | 7-19-68                 |
|                 |                         |             | 7-20-60                 |
| 615332-901      | 7-8-1                   | 616529-904  | 7-4-19                  |
| 615485-1        | 7-27-29                 |             | 7-6-18                  |
| 615506-901      | 7-4-27                  |             | 7-7-5                   |
|                 | 7-5-24                  | 616670-901  | 7-19-67                 |
|                 | 7-6-5                   | 617713-902  | 7-11-13                 |
|                 | 7-7-12                  |             | 7-20-14                 |
|                 | 7-8-10                  | 617788-901  | 7-4-20                  |
|                 | 7-19-66                 |             | 7-5-5                   |
|                 | 7-20-13                 |             | 7-19-33                 |
| 615515-901      | 7-27-22                 | 619454-901  | 7-11-54                 |
| 615660-903      | 7-7-25                  | 619905-901  | 7-19-85                 |
| 615677-901      | 7-4-36                  |             | 7-20-59                 |
|                 | 7-5-33                  |             |                         |
|                 | 7-19-77                 | 619998-2    | 7-4-49                  |
|                 | 7-27-16                 |             | 7-5-26                  |
| 615747-901      | 7-20-43                 |             | 7-20-53                 |
| 615766-902      | 7-7-13                  | 625488-1    | 7-20-73                 |
| 615796-901      | 7-8-26                  | 626482-1    | 7-20-66                 |
| 615797-903      | 7-8-20                  | 626482-2    | 7-20-65                 |
|                 |                         | 626482-3    | 7-20-67                 |
| 615883-902      | 7-9-37                  | 626483-4    | 7-18-16                 |
| 615969-901      | 7-20-20                 | 626701-1    | 7-16-1                  |
| 616000-902      | 7-8-4                   | 626701-2    | 7-24-60                 |
| 616031-901      | 7-7-23                  | 645448-901  | 7-20-3                  |
| 616049-901      | 7-7-18                  | 645503-901  | 7-5-28                  |
| 616049-902      | 7-7-16                  |             | 7-20-54                 |
| 616139-901      | 7-4-10                  |             |                         |
|                 | 7-5-12                  | 645514-901  | 7-20-35                 |
|                 | 7-19-44                 | 645516-901  | 7-20-34                 |
| 616146-901      | 7-19-24                 | 646197-901  | 7-6-9                   |
| 616172-901      | 7-20-26                 |             | 7-7-22                  |
| 616325-901      | 7-19-55                 | 646199-1    | 7-20-4                  |
|                 |                         | 646229-901  | 7-20-63                 |
| 616379-901      | 7-20-36                 | 646230-901  | 7-20-27                 |
| 616384-905      | 7-19-10                 | 646232-901  | 7-20-32                 |
|                 | 7-20-7                  | 646272-901  | 7-9-23                  |
| 616486-904      | 7-8-18                  | 646316-901  | 7-8-12                  |
| 616489-902      | 7-6-10                  | 646317-901  | 7-8-13                  |
|                 | 7-7-26                  |             |                         |
| 616492-901      | 7-4-41                  | 646318-901  | 7-8-14                  |
|                 | 7-5-31                  | 646319-901  | 7-8-15                  |

| PART NUMBER     | FIGURE AND INDEX NUMBER | PART NUMBER | FIGURE AND INDEX NUMBER |
|-----------------|-------------------------|-------------|-------------------------|
| 650155-801      | 7-18-1                  | 812086-801  | 7-2-21                  |
| 660-009B12U4-00 | 7-15-5                  |             | F7-12-                  |
| 660147-801      | 7-25-6                  | 812088-801  | 7-13-18                 |
| 660150-1        | 7-12-32                 |             | F7-15-                  |
| 660150-801      | 7-12-24                 | 812092-801  | 7-17-5                  |
| 660151-1        | 7-15-43                 |             | F7-22-                  |
| 660151-801      | 7-15-39                 | 812094-801  | 7-2-12                  |
| 660152-1        | 7-3-8                   |             | F7-4-                   |
|                 |                         | 812095-801  | 7-2-13                  |
| 660152-801      | 7-2-9                   |             | F7-5-                   |
|                 | F7-3-                   | 812097-801  | 7-24-43                 |
| 660152-802      | F7-3-                   | 812098-801  | 7-24-110                |
|                 | 7-13-4                  |             |                         |
| 660152-803      | 7-2-10                  | 812099-801  | 7-2-20                  |
|                 | F7-3-                   |             | F7-11-                  |
| 660153-1        | 7-24-107                |             | 7-22-15                 |
| 660153-801      | 7-24-103                | 812116-801  | 7-2-16                  |
| 660154-1        | 7-22-40                 |             | F7-8-                   |
| 660154-801      | 7-22-29                 | 812117-801  | 7-2-15                  |
| 660155-1        | 7-21-12                 |             | F7-7-                   |
| 660155-801      | F7-21-                  | 812118-801  | 7-16-3                  |
| 660159-1        | 7-26-25                 | 812119-801  | 7-24-108                |
|                 |                         |             | F7-25-                  |
| 660159-801      | 7-26-23                 | 812120-801  | 7-17-4                  |
| 660177-1        | 7-26-15                 |             | F7-18-                  |
| 660177-801      | 7-26-11                 | 812122-801  | 7-2-17                  |
| 707123-802      | 7-1-57                  |             | F7-9-                   |
| 707167-801      | F7-1-                   | 812126-801  | 7-18-20                 |
| 707167-802      | F7-1-                   |             | F7-20-                  |
| 722385-801      | 7-22-8                  | 812129-801  | 7-2-18                  |
| 7702501EX       | 7-19-31                 |             | F7-10-                  |
|                 | 7-20-42                 | 812132-801  | 7-24-124                |
| 7705601CX       | 7-19-63                 |             | F7-26-                  |
| 7705801EX       | 7-4-35                  |             |                         |
|                 | 7-19-69                 | 812133-801  | 7-18-19                 |
|                 | 7-20-56                 |             | F7-19-                  |
|                 |                         | 812137-801  | 7-24-67                 |
| 7717-15N        | 7-11-14                 | 812154-801  | 7-2-14                  |
|                 | 7-20-15                 |             | F7-6-                   |
| 7717-43N-BLACK  | 7-27-14                 | 812187-802  | 7-2-6                   |
| 7717-7N-WHITE   | 7-9-7                   | 812187-804  | 7-26-1                  |
| 7901001QX       | 7-8-21                  | 812424-801  | 7-26-21                 |
| 7901701QX       | 7-4-33                  |             | F7-27-                  |
|                 | 7-5-29                  | 812866-801  | 7-22-24                 |
|                 | 7-19-74                 |             | F7-23-                  |
| 7917010X        | 7-20-58                 | 812908-801  | 7-1-46                  |
| 812069-801      | 7-1-4                   | 812933-801  | 7-22-23                 |
| 812081-801      | 7-1-53                  | 812991-801  | 7-13-17                 |
|                 | F7-2-                   |             | F7-14-                  |
| 812082-801      | 7-1-54                  |             |                         |
|                 | F7-13-                  | 813198-801  | 7-18-10                 |
| 812083-801      | 7-1-55                  | 813199-801  | 7-24-87                 |
|                 | F7-16-                  | 813286-801  | 7-22-26                 |
|                 |                         | 813676-801  | 7-20-72                 |
| 812084-801      | 7-1-59                  | 813732-801  | 7-11-3                  |
|                 | F7-24-                  | 813733-801  | 7-11-30                 |
| 812084-802      | F7-1-59                 | 813820-801  | 7-11-50                 |
|                 | F7-24-                  | 813821-801  | 7-11-23                 |
| 812085-801      | 7-1-56                  | 814341-801  | 7-18-11                 |
|                 | F7-17-                  | 82-61480    | 7-15-27                 |

**T.O. 31R2-2GRC206-12**

| PART NUMBER | FIGURE AND<br>INDEX<br>NUMBER | PART NUMBER | FIGURE AND<br>INDEX<br>NUMBER |
|-------------|-------------------------------|-------------|-------------------------------|
| 82-61654    | 7-15-8                        | 938770-1    | 7-24-48                       |
| 87045-3     | 7-18-25                       |             | 7-24-116                      |
| 87046-3     | 7-12-14                       | 938770-2    | 7-24-126                      |
|             | 7-18-23                       | 938770-3    | 7-24-129                      |
|             | 7-19-81                       | 938770-4    | 7-24-127                      |
|             | 7-22-13                       | 938770-6    | 7-24-30                       |
|             | 7-22-22                       | 939053-1    | 7-27-36                       |
|             | F7-26-20                      | 939053-2    | 7-27-37                       |
| 87362-3     | 7-20-39                       | 939139-801  | 7-9-73                        |
| 87631-2     | 7-19-80                       | 939189-1    | 7-24-86                       |
| 87631-6     | 7-22-12                       | 939189-801  | 7-24-78                       |
| 938556-1    | 7-11-28                       |             |                               |
| 938573-1    | 7-2-7                         | 939205-1    | 7-15-18                       |
|             | 7-24-3                        | 939205-2    | 7-12-9                        |
| 938668-1    | 7-24-57                       | 939265-1    | 7-26-10                       |
| 938668-2    | 7-24-58                       | 939265-801  | 7-26-6                        |
|             |                               | 939462-1    | 7-24-102                      |
| 938668-801  | 7-24-56                       | 939462-801  | 7-24-98                       |
| 938669-1    | 7-21-1                        | 939463-801  | 7-24-96                       |
| 938676-1    | 7-24-77                       | 939467-1    | 7-15-32                       |
| 938676-801  | 7-24-75                       | 940254-2    | 7-11-32                       |
| 938712-1    | 7-24-71                       | 940254-801  | 7-11-33                       |
| 938712-2    | 7-24-120                      |             |                               |
| 938712-3    | 7-24-51                       | 941183-1    | 7-15-31                       |
| 938713-1    | 7-24-66                       | 941184-1    | 7-14-25                       |
| 938713-801  | 7-24-63                       | 941184-801  | 7-14-20                       |
| 938719-801  | 7-24-123                      |             |                               |

## Section IV. REFERENCE DESIGNATION INDEX

| REFERENCE DESIGNATION | VOLUME FIGURE & INDEX NO. | REFERENCE DESIGNATION | VOLUME FIGURE & INDEX NO. | REFERENCE DESIGNATION | VOLUME FIGURE & INDEX NO. |
|-----------------------|---------------------------|-----------------------|---------------------------|-----------------------|---------------------------|
| W10                   | 7- 1-41                   | 1A1C37                | 7- 4-4                    | 1A1R11                | 7- 4-28                   |
| W11                   | 7- 1-45                   | 1A1C38                | 7- 4-4                    | 1A1R12                | 7- 4-3                    |
| W12                   | 7- 1-52                   | 1A1C39                | 7- 4-4                    | 1A1R13                | 7- 4-16                   |
| W2                    | 7- 1-13                   | 1A1C4                 | 7- 4-7                    | 1A1R14                | 7- 4-26                   |
| W3                    | 7- 1-14                   | 1A1C40                | 7- 4-5                    | 1A1R15                | 7- 4-25                   |
| W4                    | 7- 1-15                   | 1A1C41                | 7- 4-44                   | 1A1R16                | 7- 4-3                    |
| W5                    | 7- 1-18                   | 1A1C42                | 7- 4-5                    | 1A1R17                | 7- 4-16                   |
| W6                    | 7- 1-24                   | 1A1C43                | 7- 4-5                    | 1A1R18                | 7- 4-16                   |
| W7                    | 7- 1-30                   | 1A1C44                | 7- 4-4                    | 1A1R19                | 7- 4-1                    |
| W8                    | 7- 1-36                   | 1A1C46                | 7- 4-5                    | 1A1R2                 | 7- 4-28                   |
| W9                    | 7- 1-37                   | 1A1C47                | 7- 4-7                    | 1A1R20                | 7- 4-16                   |
| 1                     | 7- 1-53                   | 1A1C48                | 7- 4-6                    | 1A1R21                | 7- 4-30                   |
| 1A1                   | 7- 2-12                   | 1A1C49                | 7- 4-4                    | 1A1R22                | 7- 4-30                   |
| 1A1                   | F7- 4-                    | 1A1C5                 | 7- 4-4                    | 1A1R23                | 7- 4-43                   |
| 1A1CR1                | 7- 4-13                   | 1A1C51                | 7- 4-5                    | 1A1R24                | 7- 4-17                   |
| 1A1CR2                | 7- 4-13                   | 1A1C52                | 7- 4-7                    | 1A1R25                | 7- 4-18                   |
| 1A1CR3                | 7- 4-13                   | 1A1C53                | 7- 4-5                    | 1A1R26                | 7- 4-16                   |
| 1A1CR4                | 7- 4-13                   | 1A1C54                | 7- 4-44                   | 1A1R27                | 7- 4-9                    |
| 1A1CR5                | 7- 4-11                   | 1A1C55                | 7- 4-4                    | 1A1R28                | 7- 4-9                    |
| 1A1C1                 | 7- 4-4                    | 1A1C56                | 7- 4-5                    | 1A1R3                 | 7- 4-3                    |
| 1A1C10                | 7- 4-5                    | 1A1C57                | 7- 4-5                    | 1A1R31                | 7- 4-16                   |
| 1A1C11                | 7- 4-4                    | 1A1C58                | 7- 4-6                    | 1A1R32                | 7- 4-3                    |
| 1A1C13                | 7- 4-5                    | 1A1C59                | 7- 4-7                    | 1A1R33                | 7- 4-15                   |
| 1A1C14                | 7- 4-7                    | 1A1C6                 | 7- 4-4                    | 1A1R34                | 7- 4-15                   |
| 1A1C15                | 7- 4-6                    | 1A1C60                | 7- 4-5                    | 1A1R35                | 7- 4-12                   |
| 1A1C16                | 7- 4-47                   | 1A1C61                | 7- 4-4                    | 1A1R36                | 7- 4-3                    |
| 1A1C18                | 7- 4-5                    | 1A1C63                | 7- 4-5                    | 1A1R37                | 7- 4-8                    |
| 1A1C19                | 7- 4-4                    | 1A1C7                 | 7- 4-5                    | 1A1R38                | 7- 4-9                    |
| 1A1C2                 | 7- 4-4                    | 1A1C8                 | 7- 4-44                   | 1A1R39                | 7- 4-43                   |
| 1A1C21                | 7- 4-7                    | 1A1C9                 | 7- 4-5                    | 1A1R4                 | 7- 4-16                   |
| 1A1C22                | 7- 4-5                    | 1A1FL10               | 7- 4-31                   | 1A1R40                | 7- 4-17                   |
| 1A1C23                | 7- 4-44                   | 1A1FL7                | 7- 4-31                   | 1A1R41                | 7- 4-18                   |
| 1A1C24                | 7- 4-4                    | 1A1FL8                | 7- 4-31                   | 1A1R42                | 7- 4-16                   |
| 1A1C25                | 7- 4-5                    | 1A1FL9                | 7- 4-31                   | 1A1R43                | 7- 4-9                    |
| 1A1C26                | 7- 4-5                    | 1A1J1                 | 7- 4-14                   | 1A1R44                | 7- 4-8                    |
| 1A1C27                | 7- 4-6                    | 1A1J2                 | 7- 4-29                   | 1A1R46                | 7- 4-8                    |
| 1A1C28                | 7- 4-7                    | 1A1J3                 | 7- 4-29                   | 1A1R47                | 7- 4-16                   |
| 1A1C29                | 7- 4-5                    | 1A1J4                 | 7- 4-21                   | 1A1R49                | 7- 4-9                    |
| 1A1C30                | 7- 4-4                    | 1A1L1                 | 7- 4-34                   | 1A1R5                 | 7- 4-26                   |
| 1A1C31                | 7- 4-48                   | 1A1L2                 | 7- 4-38                   | 1A1R51                | 7- 4-3                    |
| 1A1C32                | 7- 4-48                   | 1A1L3                 | 7- 4-34                   | 1A1R52                | 7- 4-9                    |
| 1A1C33                | 7- 4-7                    | 1A1P1                 | 7- 4-45                   | 1A1R53                | 7- 4-3                    |
| 1A1C34                | 7- 4-4                    | 1A1Q1                 | 7- 4-22                   | 1A1R54                | 7- 4-12                   |
| 1A1C35                | 7- 4-4                    | 1A1R1                 | 7- 4-16                   | 1A1R55                | 7- 4-8                    |
| 1A1C36                | 7- 4-4                    | 1A1R10                | 7- 4-16                   | 1A1R56                | 7- 4-8                    |

## Section IV. REFERENCE DESIGNATION INDEX - Continued

| REFERENCE DESIGNATION | VOLUME FIGURE & INDEX NO. | REFERENCE DESIGNATION | VOLUME FIGURE & INDEX NO. | REFERENCE DESIGNATION | VOLUME FIGURE & INDEX NO. |
|-----------------------|---------------------------|-----------------------|---------------------------|-----------------------|---------------------------|
| 1A1R57                | 7- 4-9                    | 1A1U16                | 7- 4-20                   | 1A2C31                | 7- 5-6                    |
| 1A1R58                | 7- 4-43                   | 1A1U17                | 7- 4-10                   | 1A2C32                | 7- 5-7                    |
| 1A1R59                | 7- 4-17                   | 1A1U18                | 7- 4-42                   | 1A2C33                | 7- 5-2                    |
| 1A1R6                 | 7- 4-25                   | 1A1U19                | 7- 4-41                   | 1A2C34                | 7- 5-7                    |
| 1A1R60                | 7- 4-18                   | 1A1U20                | 7- 4-20                   | 1A2C35                | 7- 5-36                   |
| 1A1R61                | 7- 4-16                   | 1A1U21                | 7- 4-49                   | 1A2C36                | 7- 5-2                    |
| 1A1R62                | 7- 4-9                    | 1A1U22                | 7- 4-36                   | 1A2C37                | 7- 5-2                    |
| 1A1R63                | 7- 4-9                    | 1A1U23                | 7- 4-36                   | 1A2C39                | 7- 5-6                    |
| 1A1R66                | 7- 4-16                   | 1A1U24                | 7- 4-20                   | 1A2C40                | 7- 5-2                    |
| 1A1R67                | 7- 4-3                    | 1A1U25                | 7- 4-41                   | 1A2C41                | 7- 5-7                    |
| 1A1R68                | 7- 4-15                   | 1A1U26                | 7- 4-20                   | 1A2C42                | 7- 5-10                   |
| 1A1R69                | 7- 4-15                   | 1A1U27                | 7- 4-10                   | 1A2C43                | 7- 5-2                    |
| 1A1R7                 | 7- 4-16                   | 1A1U28                | 7- 4-36                   | 1A2C45                | 7- 5-6                    |
| 1A1R70                | 7- 4-12                   | 1A1U29                | 7- 4-37                   | 1A2C46                | 7- 5-7                    |
| 1A1R71                | 7- 4-3                    | 1A1U3                 | 7- 4-33                   | 1A2C47                | 7- 5-2                    |
| 1A1R72                | 7- 4-8                    | 1A1U4                 | 7- 4-39                   | 1A2C48                | 7- 5-36                   |
| 1A1R73                | 7- 4-9                    | 1A1U5                 | 7- 4-27                   | 1A2C49                | 7- 5-6                    |
| 1A1R74                | 7- 4-43                   | 1A1U6                 | 7- 4-33                   | 1A2C5                 | 7- 5-36                   |
| 1A1R75                | 7- 4-17                   | 1A1U7                 | 7- 4-41                   | 1A2C50                | 7- 5-2                    |
| 1A1R76                | 7- 4-18                   | 1A1U8                 | 7- 4-35                   | 1A2C51                | 7- 5-2                    |
| 1A1R77                | 7- 4-16                   | 1A1U9                 | 7- 4-40                   | 1A2C52                | 7- 5-6                    |
| 1A1R78                | 7- 4-9                    | 1A2                   | 7- 2-13                   | 1A2C53                | 7- 5-2                    |
| 1A1R79                | 7- 4-8                    | 1A2                   | F7- 5-                    | 1A2C54                | 7- 5-10                   |
| 1A1R8                 | 7- 4-3                    | 1A2CR1                | 7- 5-23                   | 1A2C55                | 7- 5-7                    |
| 1A1R81                | 7- 4-8                    | 1A2CR2                | 7- 5-23                   | 1A2C56                | 7- 5-2                    |
| 1A1R82                | 7- 4-16                   | 1A2C1                 | 7- 5-7                    | 1A2C57                | 7- 5-7                    |
| 1A1R84                | 7- 4-9                    | 1A2C10                | 7- 5-10                   | 1A2C58                | 7- 5-7                    |
| 1A1R86                | 7- 4-3                    | 1A2C11                | 7- 5-7                    | 1A2C59                | 7- 5-2                    |
| 1A1R87                | 7- 4-9                    | 1A2C12                | 7- 5-2                    | 1A2C6                 | 7- 5-2                    |
| 1A1R88                | 7- 4-3                    | 1A2C13                | 7- 5-7                    | 1A2C60                | 7- 5-36                   |
| 1A1R89                | 7- 4-12                   | 1A2C14                | 7- 5-6                    | 1A2C61                | 7- 5-2                    |
| 1A1R9                 | 7- 4-16                   | 1A2C16                | 7- 5-7                    | 1A2C62                | 7- 5-2                    |
| 1A1R92                | 7- 4-9                    | 1A2C18                | 7- 5-2                    | 1A2C64                | 7- 5-6                    |
| 1A1R93                | 7- 4-47                   | 1A2C19                | 7- 5-36                   | 1A2C65                | 7- 5-2                    |
| 1A1R94                | 7- 4-47                   | 1A2C2                 | 7- 5-7                    | 1A2C66                | 7- 5-7                    |
| 1A1R95                | 7- 4-16                   | 1A2C20                | 7- 5-2                    | 1A2C67                | 7- 5-10                   |
| 1A1T1                 | 7- 4-2                    | 1A2C22                | 7- 5-6                    | 1A2C68                | 7- 5-2                    |
| 1A1T2                 | 7- 4-2                    | 1A2C23                | 7- 5-2                    | 1A2C69                | 7- 5-7                    |
| 1A1U1                 | 7- 4-27                   | 1A2C24                | 7- 5-2                    | 1A2C7                 | 7- 5-2                    |
| 1A1U10                | 7- 4-37                   | 1A2C25                | 7- 5-7                    | 1A2C70                | 7- 5-2                    |
| 1A1U11                | 7- 4-37                   | 1A2C26                | 7- 5-10                   | 1A2C71                | 7- 5-36                   |
| 1A1U12                | 7- 4-42                   | 1A2C27                | 7- 5-6                    | 1A2C72                | 7- 5-6                    |
| 1A1U13                | 7- 4-19                   | 1A2C29                | 7- 5-6                    | 1A2C74                | 7- 5-6                    |
| 1A1U14                | 7- 4-36                   | 1A2C3                 | 7- 5-6                    | 1A2C75                | 7- 5-2                    |
| 1A1U15                | 7- 4-36                   | 1A2C30                | 7- 5-6                    | 1A2C76                | 7- 5-2                    |

## Section IV. REFERENCE DESIGNATION INDEX - Continued

| REFERENCE DESIGNATION | VOLUME FIGURE & INDEX NO. | REFERENCE DESIGNATION | VOLUME FIGURE & INDEX NO. | REFERENCE DESIGNATION | VOLUME FIGURE & INDEX NO. |
|-----------------------|---------------------------|-----------------------|---------------------------|-----------------------|---------------------------|
| 1A2C78                | 7- 5-6                    | 1A2R127               | 7- 5-17                   | 1A2R59                | 7- 5-4                    |
| 1A2C79                | 7- 5-10                   | 1A2R14                | 7- 5-8                    | 1A2R6                 | 7- 5-1                    |
| 1A2C8                 | 7- 5-2                    | 1A2R15                | 7- 5-4                    | 1A2R60                | 7- 5-8                    |
| 1A2C80                | 7- 5-7                    | 1A2R16                | 7- 5-38                   | 1A2R61                | 7- 5-11                   |
| 1A2C81                | 7- 5-2                    | 1A2R18                | 7- 5-9                    | 1A2R63                | 7- 5-35                   |
| 1A2C82                | 7- 5-6                    | 1A2R19                | 7- 5-9                    | 1A2R64                | 7- 5-3                    |
| 1A2C83                | 7- 5-3                    | 1A2R2                 | 7- 5-3                    | 1A2R65                | 7- 5-15                   |
| 1A2C85                | 7- 5-2                    | 1A2R20                | 7- 5-25                   | 1A2R66                | 7- 5-14                   |
| 1A2C9                 | 7- 5-6                    | 1A2R21                | 7- 5-1                    | 1A2R67                | 7- 5-1                    |
| 1A2C99                | 7- 5-3                    | 1A2R22                | 7- 5-35                   | 1A2R68                | 7- 5-11                   |
| 1A2J1                 | 7- 5-48                   | 1A2R23                | 7- 5-3                    | 1A2R70                | 7- 5-11                   |
| 1A2J2                 | 7- 5-18                   | 1A2R24                | 7- 5-15                   | 1A2R71                | 7- 5-14                   |
| 1A2J3                 | 7- 5-27                   | 1A2R25                | 7- 5-14                   | 1A2R73                | 7- 5-1                    |
| 1A2L4                 | 7- 5-34                   | 1A2R26                | 7- 5-1                    | 1A2R76                | 7- 5-9                    |
| 1A2P1                 | 7- 5-46                   | 1A2R27                | 7- 5-1                    | 1A2R77                | 7- 5-9                    |
| 1A2Q2                 | 7- 5-40                   | 1A2R29                | 7- 5-14                   | 1A2R78                | 7- 5-8                    |
| 1A2Q3                 | 7- 5-41                   | 1A2R3                 | 7- 5-15                   | 1A2R79                | 7- 5-11                   |
| 1A2Q4                 | 7- 5-41                   | 1A2R31                | 7- 5-9                    | 1A2R8                 | 7- 5-11                   |
| 1A2Q5                 | 7- 5-40                   | 1A2R32                | 7- 5-37                   | 1A2R80                | 7- 5-11                   |
| 1A2Q6                 | 7- 5-41                   | 1A2R33                | 7- 5-4                    | 1A2R81                | 7- 5-1                    |
| 1A2Q7                 | 7- 5-41                   | 1A2R34                | 7- 5-8                    | 1A2R82                | 7- 5-35                   |
| 1A2R1                 | 7- 5-35                   | 1A2R35                | 7- 5-9                    | 1A2R84                | 7- 5-15                   |
| 1A2R100               | 7- 5-15                   | 1A2R36                | 7- 5-9                    | 1A2R85                | 7- 5-14                   |
| 1A2R101               | 7- 5-14                   | 1A2R37                | 7- 5-1                    | 1A2R86                | 7- 5-1                    |
| 1A2R102               | 7- 5-1                    | 1A2R38                | 7- 5-9                    | 1A2R87                | 7- 5-1                    |
| 1A2R103               | 7- 5-11                   | 1A2R39                | 7- 5-45                   | 1A2R9                 | 7- 5-1                    |
| 1A2R105               | 7- 5-11                   | 1A2R4                 | 7- 5-14                   | 1A2R90                | 7- 5-14                   |
| 1A2R106               | 7- 5-14                   | 1A2R40                | 7- 5-52                   | 1A2R91                | 7- 5-9                    |
| 1A2R108               | 7- 5-1                    | 1A2R41                | 7- 5-44                   | 1A2R913               | 7- 5-9                    |
| 1A2R111               | 7- 5-9                    | 1A2R42                | 7- 5-49                   | 1A2R92                | 7- 5-4                    |
| 1A2R112               | 7- 5-8                    | 1A2R43                | 7- 5-45                   | 1A2R93                | 7- 5-4                    |
| 1A2R113               | 7- 5-11                   | 1A2R44                | 7- 5-43                   | 1A2R94                | 7- 5-8                    |
| 1A2R114               | 7- 5-4                    | 1A2R45                | 7- 5-44                   | 1A2R95                | 7- 5-9                    |
| 1A2R115               | 7- 5-1                    | 1A2R46                | 7- 5-42                   | 1A2R96                | 7- 5-11                   |
| 1A2R116               | 7- 5-121                  | 1A2R47                | 7- 5-14                   | 1A2R97                | 7- 5-1                    |
| 1A2R117               | 7- 5-22                   | 1A2R48                | 7- 5-35                   | 1A2R98                | 7- 5-35                   |
| 1A2R118               | 7- 5-20                   | 1A2R49                | 7- 5-3                    | 1A2U1                 | 7- 5-33                   |
| 1A2R119               | 7- 5-9                    | 1A2R5                 | 7- 5-11                   | 1A2U10                | 7- 5-32                   |
| 1A2R120               | 7- 5-16                   | 1A2R50                | 7- 5-15                   | 1A2U11                | 7- 5-31                   |
| 1A2R121               | 7- 5-16                   | 1A2R51                | 7- 5-14                   | 1A2U12                | 7- 5-29                   |
| 1A2R122               | 7- 5-19                   | 1A2R52                | 7- 5-1                    | 1A2U13                | 7- 5-28                   |
| 1A2R123               | 7- 5-9                    | 1A2R53                | 7- 5-1                    | 1A2U14                | 7- 5-26                   |
| 1A2R124               | 7- 5-9                    | 1A2R56                | 7- 5-14                   | 1A2U15                | 7- 5-26                   |
| 1A2R125               | 7- 5-14                   | 1A2R57                | 7- 5-9                    | 1A2U16                | 7- 5-33                   |
| 1A2R126               | 7- 5-14                   | 1A2R58                | 7- 5-4                    | 1A2U17                | 7- 5-33                   |

## Section IV. REFERENCE DESIGNATION INDEX - Continued

| REFERENCE DESIGNATION | VOLUME FIGURE & INDEX NO. | REFERENCE DESIGNATION | VOLUME FIGURE & INDEX NO. | REFERENCE DESIGNATION | VOLUME FIGURE & INDEX NO. |
|-----------------------|---------------------------|-----------------------|---------------------------|-----------------------|---------------------------|
| 1A2U18                | 7- 5-5                    | 1A3C6                 | 7- 6-4                    | 1A3R49                | 7- 6-2                    |
| 1A2U19                | 7- 5-12                   | 1A3C7                 | 7- 6-4                    | 1A3R5                 | 7- 6-3                    |
| 1A2U2                 | 7- 5-31                   | 1A3C8                 | 7- 6-4                    | 1A3R50                | 7- 6-3                    |
| 1A2U20                | 7- 5-31                   | 1A3C9                 | 7- 6-4                    | 1A3R51                | 7- 6-7                    |
| 1A2U21                | 7- 5-31                   | 1A3P1                 | 7- 6-19                   | 1A3R52                | 7- 6-7                    |
| 1A2U22                | 7- 5-5                    | 1A3R1                 | 7- 6-6                    | 1A3R53                | 7- 6-12                   |
| 1A2U23                | 7- 5-33                   | 1A3R10                | 7- 6-2                    | 1A3R54                | 7- 6-12                   |
| 1A2U24                | 7- 5-33                   | 1A3R11                | 7- 6-3                    | 1A3R55                | 7- 6-12                   |
| 1A2U25                | 7- 5-5                    | 1A3R12                | 7- 6-2                    | 1A3R56                | 7- 6-12                   |
| 1A2U26                | 7- 5-12                   | 1A3R13                | 7- 6-2                    | 1A3R57                | 7- 6-13                   |
| 1A2U27                | 7- 5-31                   | 1A3R14                | 7- 6-3                    | 1A3R58                | 7- 6-14                   |
| 1A2U28                | 7- 5-5                    | 1A3R15                | 7- 6-7                    | 1A3R59                | 7- 6-6                    |
| 1A2U3                 | 7- 5-33                   | 1A3R16                | 7- 6-2                    | 1A3R6                 | 7- 6-2                    |
| 1A2U4                 | 7- 5-5                    | 1A3R17                | 7- 6-2                    | 1A3R60                | 7- 6-12                   |
| 1A2U5                 | 7- 5-12                   | 1A3R18                | 7- 6-2                    | 1A3R61                | 7- 6-12                   |
| 1A2U6                 | 7- 5-24                   | 1A3R19                | 7- 6-3                    | 1A3R62                | 7- 6-12                   |
| 1A2U7                 | 7- 5-39                   | 1A3R2                 | 7- 6-6                    | 1A3R63                | 7- 6-12                   |
| 1A2U9                 | 7- 5-5                    | 1A3R20                | 7- 6-2                    | 1A3R7                 | 7- 6-2                    |
| 1A3                   | 7- 2-14                   | 1A3R21                | 7- 6-2                    | 1A3R8                 | 7- 6-3                    |
| 1A3                   | F7- 6-                    | 1A3R22                | 7- 6-3                    | 1A3R9                 | 7- 6-2                    |
| 1A3CR1                | 7- 6-1                    | 1A3R24                | 7- 6-2                    | 1A3TP1                | 7- 6-8                    |
| 1A3CR10               | 7- 6-1                    | 1A3R25                | 7- 6-3                    | 1A3TP2                | 7- 6-8                    |
| 1A3CR11               | 7- 6-1                    | 1A3R26                | 7- 6-2                    | 1A3TP3                | 7- 6-8                    |
| 1A3CR12               | 7- 6-1                    | 1A3R27                | 7- 6-2                    | 1A3TP4                | 7- 6-8                    |
| 1A3CR13               | 7- 6-1                    | 1A3R28                | 7- 6-3                    | 1A3U1                 | 7- 6-10                   |
| 1A3CR14               | 7- 6-1                    | 1A3R29                | 7- 6-7                    | 1A3U10                | 7- 6-9                    |
| 1A3CR2                | 7- 6-1                    | 1A3R3                 | 7- 6-2                    | 1A3U11                | 7- 6-9                    |
| 1A3CR3                | 7- 6-1                    | 1A3R30                | 7- 6-2                    | 1A3U12                | 7- 6-9                    |
| 1A3CR4                | 7- 6-1                    | 1A3R31                | 7- 6-16                   | 1A3U13                | 7- 6-11                   |
| 1A3CR5                | 7- 6-1                    | 1A3R32                | 7- 6-2                    | 1A3U14                | 7- 6-5                    |
| 1A3CR6                | 7- 6-1                    | 1A3R33                | 7- 6-3                    | 1A3U2                 | 7- 6-18                   |
| 1A3CR7                | 7- 6-1                    | 1A3R34                | 7- 6-16                   | 1A3U3                 | 7- 6-18                   |
| 1A3CR8                | 7- 6-1                    | 1A3R35                | 7- 6-2                    | 1A3U4                 | 7- 6-17                   |
| 1A3CR9                | 7- 6-1                    | 1A3R36                | 7- 6-3                    | 1A3U5                 | 7- 6-17                   |
| 1A3C1                 | 7- 6-4                    | 1A3R37                | 7- 6-16                   | 1A3U6                 | 7- 6-5                    |
| 1A3C10                | 7- 6-4                    | 1A3R38                | 7- 6-2                    | 1A3U7                 | 7- 6-5                    |
| 1A3C11                | 7- 6-4                    | 1A3R4                 | 7- 6-2                    | 1A3U8                 | 7- 6-5                    |
| 1A3C12                | 7- 6-4                    | 1A3R40                | 7- 6-7                    | 1A3U9                 | 7- 6-5                    |
| 1A3C13                | 7- 6-4                    | 1A3R41                | 7- 6-7                    | 1A4                   | 7- 2-15                   |
| 1A3C14                | 7- 6-21                   | 1A3R42                | 7- 6-16                   | 1A4                   | F7- 7-                    |
| 1A3C15                | 7- 6-4                    | 1A3R43                | 7- 6-2                    | 1A4CR1                | 7- 7-9                    |
| 1A3C2                 | 7- 6-4                    | 1A3R45                | 7- 6-16                   | 1A4CR10               | 7- 7-1                    |
| 1A3C3                 | 7- 6-4                    | 1A3R46                | 7- 6-2                    | 1A4CR11               | 7- 7-1                    |
| 1A3C4                 | 7- 6-4                    | 1A3R47                | 7- 6-3                    | 1A4CR12               | 7- 7-1                    |
| 1A3C5                 | 7- 6-4                    | 1A3R48                | 7- 6-16                   | 1A4CR13               | 7- 7-1                    |



## Section IV. REFERENCE DESIGNATION INDEX - Continued

| REFERENCE DESIGNATION | VOLUME FIGURE & INDEX NO. | REFERENCE DESIGNATION | VOLUME FIGURE & INDEX NO. | REFERENCE DESIGNATION | VOLUME FIGURE & INDEX NO. |
|-----------------------|---------------------------|-----------------------|---------------------------|-----------------------|---------------------------|
| 1A4CR14               | 7- 7-1                    | 1A4C8                 | 7- 7-6                    | 1A4R4                 | 7- 7-2                    |
| 1A4CR15               | 7- 7-1                    | 1A4C9                 | 7- 7-6                    | 1A4R40                | 7- 7-4                    |
| 1A4CR16               | 7 7-1                     | 1A4P1                 | 7- 7-28                   | 1A4R41                | 7- 7-4                    |
| 1A4CR17               | 7- 7-1                    | 1A4Q1                 | 7- 7-3                    | 1A4R42                | 7- 7-19                   |
| 1A4CR18               | 7- 7-1                    | 1A4Q10                | 7- 7-3                    | 1A4R43                | 7- 7-19                   |
| 1A4CR19               | 7- 7-1                    | 1A4Q2                 | 7- 7-3                    | 1A4R45                | 7- 7-8                    |
| 1A4CR2                | 7- 7-9                    | 1A4Q3                 | 7- 7-3                    | 1A4R46                | 7- 7-7                    |
| 1A4CR20               | 7- 7-1                    | 1A4Q4                 | 7- 7-3                    | 1A4R47                | 7- 7-14                   |
| 1A4CR21               | 7- 7-1                    | 1A4Q5                 | 7- 7-3                    | 1A4R48                | 7- 7-20                   |
| 1A4CR22               | 7- 7-1                    | 1A4Q6                 | 7- 7-3                    | 1A4R5                 | 7- 7-2                    |
| 1A4CR23               | 7- 7-1                    | 1A4Q7                 | 7- 7-3                    | 1A4R6                 | 7- 7-2                    |
| 1A4CR24               | 7- 7-1                    | 1A4Q9                 | 7- 7-3                    | 1A4R7                 | 7- 7-2                    |
| 1A4CR25               | 7- 7-1                    | 1A4R1                 | 7- 7-2                    | 1A4R8                 | 7- 7-2                    |
| 1A4CR26               | 7- 7-1                    | 1A4R10                | 7- 7-2                    | 1A4R9                 | 7- 7-2                    |
| 1A4CR27               | 7- 7-1                    | 1A4R11                | 7- 7-11                   | 1A4TP1                | 7- 7-10                   |
| 1A4CR28               | 7- 7-1                    | 1A4R12                | 7- 7-8                    | 1A4TP2                | 7- 7-10                   |
| 1A4CR29               | 7- 7-1                    | 1A4R13                | 7- 7-8                    | 1A4U1                 | 7- 7-25                   |
| 1A4CR3                | 7- 7-9                    | 1A4R14                | 7- 7-8                    | 1A4U10                | 7- 7-16                   |
| 1A4CR30               | 7- 7-1                    | 1A4R15                | 7- 7-7                    | 1A4U11                | 7- 7-22                   |
| 1A4CR31               | 7- 7-1                    | 1A4R16                | 7- 7-8                    | 1A4U12                | 7- 7-12                   |
| 1A4CR32               | 7- 7-1                    | 1A4R17                | 7- 7-8                    | 1A4U13                | 7- 7-13                   |
| 1A4CR33               | 7- 7-1                    | 1A4R18                | 7- 7-7                    | 1A4U14                | 7- 7-23                   |
| 1A4CR34               | 7- 7-1                    | 1A4R19                | 7- 7-8                    | 1A4U2                 | 7- 7-26                   |
| 1A4CR35               | 7- 7-1                    | 1A4R2                 | 7- 7-2                    | 1A4U3                 | 7- 7-26                   |
| 1A4CR36               | 7- 7-1                    | 1A4R20                | 7- 7-8                    | 1A4U5                 | 7- 7-5                    |
| 1A4CR37               | 7- 7-1                    | 1A4R21                | 7- 7-7                    | 1A4U6                 | 7- 7-5                    |
| 1A4CR38               | 7- 7-1                    | 1A4R22                | 7- 7-8                    | 1A4U7                 | 7- 7-12                   |
| 1A4CR4                | 7- 7-9                    | 1A4R23                | 7- 7-8                    | 1A4U8                 | 7- 7-12                   |
| 1A4CR5                | 7- 7-9                    | 1A4R24                | 7- 7-7                    | 1A4U9                 | 7- 7-18                   |
| 1A4CR6                | 7- 7-9                    | 1A4R25                | 7- 7-17                   | 1A5                   | 7- 2-16                   |
| 1A4CR7                | 7- 7-9                    | 1A4R26                | 7- 7-17                   | 1A5                   | F7- 8-                    |
| 1A4CR8                | 7- 7-1                    | 1A4R27                | 7- 7-11                   | 1A5CR1                | 7- 8-7                    |
| 1A4CR9                | 7- 7-1                    | 1A4R28                | 7- 7-8                    | 1A5CR2                | 7- 8-7                    |
| 1A4C1                 | 7- 7-6                    | 1A4R29                | 7- 7-21                   | 1A5C1                 | 7- 8-3                    |
| 1A4C10                | 7- 7-6                    | 1A4R3                 | 7- 7-2                    | 1A5C10                | 7- 8-3                    |
| 1A4C11                | 7- 7-6                    | 1A4R30                | 7- 7-8                    | 1A5C11                | 7- 8-3                    |
| 1A4C12                | 7- 7-6                    | 1A4R31                | 7- 7-21                   | 1A5C12                | 7- 8-3                    |
| 1A4C13                | 7- 7-30                   | 1A4R32                | 7- 7-21                   | 1A5C13                | 7- 8-3                    |
| 1A4C14                | 7- 7-6                    | 1A4R33                | 7- 7-8                    | 1A5C14                | 7- 8-3                    |
| 1A4C15                | 7- 7-6                    | 1A4R34                | 7- 7-8                    | 1A5C15                | 7- 8-11                   |
| 1A4C2                 | 7- 7-6                    | 1A4R35                | 7- 7-11                   | 1A5C16                | 7- 8-3                    |
| 1A4C3                 | 7- 7-6                    | 1A4R36                | 7- 7-8                    | 1A5C17                | 7- 8-3                    |
| 1A4C5                 | 7- 7-6                    | 1A4R37                | 7- 7-8                    | 1A5C2                 | 7- 8-3                    |
| 1A4C6                 | 7- 7-24                   | 1A4R38                | 7- 7-7                    | 1A5C22                | 7- 8-3                    |
| 1A4C7                 | 7- 7-6                    | 1A4R39                | 7- 7-4                    | 1A5C23                | 7- 8-3                    |

## Section IV. REFERENCE DESIGNATION INDEX - Continued

| REFERENCE DESIGNATION | VOLUME FIGURE & INDEX NO. | REFERENCE DESIGNATION | VOLUME FIGURE & INDEX NO. | REFERENCE DESIGNATION | VOLUME FIGURE & INDEX NO. |
|-----------------------|---------------------------|-----------------------|---------------------------|-----------------------|---------------------------|
| 1A5C26                | 7- 8-3                    | 1A6                   | 7- 2-17                   | 1A6L2                 | 7- 9-27                   |
| 1A5C27                | 7- 8-3                    | 1A6                   | F7- 9-                    | 1A6L3                 | 7- 9-19                   |
| 1A5C28                | 7- 8-27                   | 1A6CR1                | 7- 9-9                    | 1A6P1                 | 7- 9-64                   |
| 1A5C29                | 7- 8-3                    | 1A6CR10               | 7- 9-9                    | 1A6Q1                 | 7- 9-6                    |
| 1A5C3                 | 7- 8-3                    | 1A6CR2                | 7- 9-9                    | 1A6Q2                 | 7- 9-68                   |
| 1A5C30                | 7- 8-3                    | 1A6CR3                | 7- 9-9                    | 1A6Q3                 | 7- 9-68                   |
| 1A5C31                | 7- 8-3                    | 1A6CR4                | 7- 9-9                    | 1A6Q4                 | 7- 9-6                    |
| 1A5C32                | 7- 8-3                    | 1A6CR5                | 7- 9-9                    | 1A6Q5                 | 7- 9-6                    |
| 1A5C5                 | 7- 8-3                    | 1A6CR6                | 7- 9-9                    | 1A6Q6                 | 7- 9-14                   |
| 1A5C8                 | 7- 8-3                    | 1A6CR7                | 7- 9-9                    | 1A6Q7                 | 7- 9-6                    |
| 1A5C9                 | 7- 8-3                    | 1A6CR8                | 7- 9-9                    | 1A6R1                 | 7- 9-1                    |
| 1A5P1                 | 7- 8-24                   | 1A6CR9                | 7- 9-9                    | 1A6R10                | 7- 9-46                   |
| 1A5R1                 | 7- 8-17                   | 1A6C1                 | 7- 9-5                    | 1A6R11                | 7- 9-58                   |
| 1A5R11                | 7- 8-9                    | 1A6C10                | 7- 9-30                   | 1A6R12                | 7- 9-58                   |
| 1A5R12                | 7- 8-9                    |                       |                           | 1A6R13                | 7- 9-60                   |
| 1A5R13                | 7- 8-9                    | 1A6C11                | 7- 9-29                   | 1A6R14                | 7- 9-52                   |
| 1A5R14                | 7- 8-9                    | 1A6C12                | 7- 9-12                   | 1A6R15                | 7- 9-26                   |
| 1A5R15                | 7- 8-23                   | 1A6C13                | 7- 9-29                   | 1A6R16                | 7- 9-59                   |
| 1A5R2                 | 7- 8-17                   | 1A6C14                | 7- 9-12                   | 1A6R17                | 7- 9-58                   |
| 1A5R3                 | 7- 8-17                   | 1A6C15                | 7- 9-8                    | 1A6R18                | 7- 9-46                   |
| 1A5R4                 | 7- 8-17                   | 1A6C16                | 7- 9-51                   | 1A6R19                | 7- 9-58                   |
| 1A5R5                 | 7- 8-6                    | 1A6C17                | 7- 9-12                   | 1A6R2                 | 7- 9-2                    |
| 1A5R6                 | 7- 8-5                    | 1A6C18                | 7- 9-8                    | 1A6R20                | 7- 9-58                   |
| 1A5R7                 | 7- 8-8                    | 1A6C19                | 7- 9-51                   | 1A6R21                | 7- 9-60                   |
| 1A5R8                 | 7- 8-22                   | 1A6C2                 | 7- 9-12                   | 1A6R22                | 7- 9-57                   |
| 1A5R9                 | 7- 8-22                   | 1A6C20                | 7- 9-12                   | 1A6R23                | 7- 9-36                   |
| 1A5U1                 | 7- 8-12                   | 1A6C22                | 7- 9-12                   | 1A6R24                | 7- 9-52                   |
| 1A5U10                | 7- 8-18                   | 1A6C23                | 7- 9-17                   | 1A6R25                | 7- 9-32                   |
| 1A5U11                | 7- 8-18                   | 1A6C24                | 7- 9-67                   | 1A6R26                | 7- 9-15                   |
| 1A5U12                | 7- 8-10                   | 1A6C25                | 7- 9-66                   | 1A6R27                | 7- 9-16                   |
| 1A5U13                | 7- 8-2                    | 1A6C26                | 7- 9-8                    | 1A6R28                | 7- 9-15                   |
| 1A5U18                | 7- 8-4                    | 1A6C27                | 7- 9-8                    | 1A6R29                | 7- 9-34                   |
| 1A5U19                | 7- 8-4                    | 1A6C28                | 7- 9-8                    | 1A6R3                 | 7- 9-52                   |
| 1A5U2                 | 7- 8-13                   | 1A6C29                | 7- 9-8                    | 1A6R30                | 7- 9-42                   |
| 1A5U22                | 7- 8-19                   | 1A6C3                 | 7- 9-8                    | 1A6R31                | 7- 9-45                   |
| 1A5U23                | 7- 8-19                   | 1A6C30                | 7- 9-8                    | 1A6R32                | 7- 9-46                   |
| 1A5U24                | 7- 8-1                    | 1A6C4                 | 7- 9-17                   | 1A6R33                | 7- 9-42                   |
| 1A5U25                | 7- 8-28                   | 1A6C5                 | 7- 9-12                   | 1A6R34                | 7- 9-43                   |
| 1A5U3                 | 7- 8-14                   | 1A6C6                 | 7- 9-8                    | 1A6R35                | 7- 9-44                   |
| 1A5U4                 | 7- 8-15                   | 1A6C7                 | 7- 9-56                   | 1A6R36                | 7- 9-33                   |
| 1A5U5                 | 7- 8-21                   | 1A6C8                 | 7- 9-53                   | 1A6R37                | 7- 9-35                   |
| 1A5U6                 | 7- 8-20                   | 1A6C9                 | 7- 9-53                   | 1A6R39                | 7- 9-54                   |
| 1A5U7                 | 7- 8-26                   | 1A6E1                 | 7- 9-50                   | 1A6R4                 | 7- 9-49                   |
| 1A5U8                 | 7- 8-2                    | 1A6E2                 | 7- 9-50                   | 1A6R40                | 7- 9-61                   |
| 1A5U9                 | 7- 8-2                    | 1A6L1                 | 7- 9-71                   | 1A6R41                | 7- 9-54                   |

## Section IV. REFERENCE DESIGNATION INDEX - Continued

| REFERENCE DESIGNATION | VOLUME FIGURE & INDEX NO. | REFERENCE DESIGNATION | VOLUME FIGURE & INDEX NO. | REFERENCE DESIGNATION | VOLUME FIGURE & INDEX NO. |
|-----------------------|---------------------------|-----------------------|---------------------------|-----------------------|---------------------------|
| 1A6R43                | 7- 9-11                   | 1A8A1P1               | 7-11-22                   | 1J10                  | 7-12-10                   |
| 1A6R44                | 7- 9-11                   | 1A8A1Q1               | 7-11-13                   | 1J11                  | 7-12-5                    |
| 1A6R45                | 7- 9-11                   | 1A8A1Q2               | 7-11-17                   | 1J12                  | 7-12-6                    |
| 1A6R46                | 7- 9-18                   | 1A8A1R1               | 7-11-19                   | 1J13                  | 7-12-6                    |
| 1A6R47                | 7- 9-10                   | 1A8A1R3               | 7-11-11                   | 1J14                  | 7-12-7                    |
| 1A6R5                 | 7- 9-52                   | 1A8A1R4               | 7-11-26                   | 1J3                   | 7-12-11                   |
| 1A6R6                 | 7- 9-31                   | 1A8A1R5               | 7-11-9                    | 1J4                   | 7-12-11                   |
| 1A6R7                 | 7- 9-69                   | 1A8A1R6               | 7-11-15                   | 1J5                   | 7-12-11                   |
| 1A6R8                 | 7- 9-62                   | 1A8A1R7               | 7-11-10                   | 1J6                   | 7-12-11                   |
| 1A6R9                 | 7- 9-63                   | 1A8A2                 | 7-11-30                   | 1J7                   | 7-12-11                   |
| 1A6U1                 | 7- 9-23                   | 1A8A2CR1              | 7-11-50                   | 1J8                   | 7-12-4                    |
| 1A6U2                 | 7- 9-55                   | 1A8A2CR2              | 7-11-42                   | 1J9                   | 7-12-4                    |
| 1A6U3                 | 7- 9-55                   | 1A8A2CR3              | 7-11-42                   | 1P1                   | 7-12-18                   |
| 1A6U4                 | 7- 9-23                   | 1A8A2CR4              | 7-11-49                   | 1P2                   | 7-12-18                   |
| 1A6U5                 | 7- 9-37                   | 1A8A2C1               | 7-11-37                   | 1P3                   | 7-12-13                   |
| 1A6U6                 | 7- 9-37                   | 1A8A2C2               | 7-11-37                   | 2                     | 7- 1-54                   |
| 1A6VR1                | 7- 9-70                   | 1A8A2C3               | 7-11-40                   | 2                     | F7-13-                    |
|                       |                           | 1A8A2C4               | 7-11-45                   | 2A1                   | 7-13-18                   |
| 1A6VR2                | 7- 9-48                   | 1A8A2C5               | 7-11-40                   | 2A1CB1                | 7-15-17                   |
| 1A6VR3                | 7- 9-48                   | 1A8A2C6               | 7-11-37                   | 2A1CB2                | 7-15-9                    |
| 1A6VR4                | 7- 9-13                   | 1A8A2C7               | 7-11-37                   | 2A1CB3                | 7-15-9                    |
| 1A6VR5                | 7- 9-47                   | 1A8A2C8               | 7-11-40                   | 2A1DS1                | 7-15-10                   |
| 1A7                   | 7- 2-18                   | 1A8A2J1               | 7-11-34                   | 2A1DS2                | 7-15-13                   |
| 1A7                   | F7-10-                    | 1A8A2L1               | 7-11-39                   | 2A1E1                 | 7-15-14                   |
| 1A7J1                 | 7-10-7                    | 1A8A2R1               | 7-11-38                   | 2A1E1                 | 7-15-14                   |
| 1A7J2                 | 7-10-7                    | 1A8A2R10              | 7-11-48                   | 2A1E2                 | 7-15-14                   |
| 1A7J3                 | 7-10-5                    | 1A8A2R2               | 7-11-38                   | 2A1E3                 | 7-15-14                   |
| 1A7J4                 | 7-10-5                    | 1A8A2R3               | 7-11-46                   | 2A1E4                 | 7-15-14                   |
| 1A7J5                 | 7-10-3                    | 1A8A2R4               | 7-11-44                   | 2A1E5                 | 7-15-14                   |
| 1A7J6                 | 7-10-3                    | 1A8A2R5               | 7-11-43                   | 2A2E6                 | 7-15-14                   |
| 1A7J7                 | 7-10-3                    | 1A8A2R6               | 7-11-36                   | 2A1J1                 | 7-15-3                    |
| 1A7J8                 | 7-10-1                    | 1A8A2R7               | 7-11-36                   | 2A1J2                 | 7-15-3                    |
| 1A8                   | 7- 2-20                   | 1A8A2R8               | 7-11-53                   | 2A1J3                 | 7-15-6                    |
| 1A8                   | F7-11-                    | 1A8A2R9               | 7-11-47                   | 2A1J4                 | 7-15-25                   |
| 1A8A1                 | 7-11-3                    | 1A8A2TP1              | 7-11-35                   | 2A1J5                 | 7-15-25                   |
| 1A8A1CR1              | 7-11-16                   | 1A8A2U1               | 7-11-41                   | 2A1J6                 | 7-15-28                   |
| 1A8A1CR2              | 7-11-16                   | 1A8A2U2               | 7-11-41                   | 2A1L1                 | 7-15-29                   |
| 1A8A1CR3              | 7-11-20                   | 1A8A2U3               | 7-11-54                   | 2A1M1                 | 7-15-22                   |
| 1A8A1CR4              | 7-11-6                    | 1A8J1                 | 7-11-1                    | 2A1S1                 | 7-15-21                   |
| 1A8A1CR5              | 7-11-6                    | 1A9 SAME AS 1A8       | 7-2-20                    | 2A2                   | 7-13-17                   |
| 1A8A1CR6              | 7-11-12                   | 1CB1                  | 7-12-8                    | 2A2CR1                | 7-14-8                    |
| 1A8A1CR7              | 7-11-23                   | 1E1                   | 7-12-22                   | 2A2CR2                | 7-14-19                   |
| 1A8A1C1               | 7-11-5                    | 1E2                   | 7-12-22                   | 2A2CR3                | 7-14-12                   |
| 1A8A1C2               | 7-11-5                    | 1E3                   | 7-12-17                   | 2A2CR4                | 7-14-7                    |
| 1A8A1J1               | 7-11-8                    | 1E4                   | 7-12-20                   | 2A2C1                 | 7-14-6                    |

## Section IV. REFERENCE DESIGNATION INDEX - Continued

| REFERENCE DESIGNATION | VOLUME FIGURE & INDEX NO. | REFERENCE DESIGNATION | VOLUME FIGURE & INDEX NO. | REFERENCE DESIGNATION | VOLUME FIGURE & INDEX NO. |
|-----------------------|---------------------------|-----------------------|---------------------------|-----------------------|---------------------------|
| 2R1                   | 7-13-5                    | 4A1A1R23              | 7-27-15                   | 5A1A1Q4               | 7-23-9                    |
| 3                     | 7- 1-55                   | 4A1A1R3               | 7-27-19                   | 5A1A1R1               | 7-23-12                   |
| 3A1                   | 7-16-1                    | 4A1A1R4               | 7-27-3                    | 5A1A1R2               | 7-23-13                   |
| 3A2                   | 7-16-3                    | 4A1A1R5               | 7-27-5                    | 5A1A1R3               | 7-23-5                    |
| 3W1                   | 7-16-2                    | 4A1A1R6               | 7-27-30                   | 5A1A1R4               | 7-23-11                   |
| 4                     | 7- 1-59                   | 4A1A1R7               | 7-27-23                   | 5A1A1R5               | 7-23-8                    |
| 4A1                   | 7-24-124                  | 4A1A1R8               | 7-27-26                   | 5A1A1R6               | 7-23-6                    |
| 4A1                   | F7-26-                    | 4A1A1R9               | 7-27-5                    | 5A1A1R7               | 7-23-11                   |
| 4A1A1                 | 7-26-21                   | 4A1A1TP1              | 7-27-25                   | 5A1A1R8               | 7-23-8                    |
| 4A1A1                 | F7-27-                    | 4A1A1TP2              | 7-27-25                   | 5A1A2                 | 7-22-23                   |
| 4A1A1CR1              | 7-27-2                    | 4A1A1T1               | 7-27-34                   | 5A1A3                 | 7-22-26                   |
| 4A1A1CR2              | 7-27-4                    | 4A1A1U1               | 7-27-21                   | 5A1A4SAME AS 1A8      | 7-22-15                   |
| 4A1A1CR3              | 7-27-29                   | 4A1A1U2               | 7-27-16                   | 5A1E9                 | 7-22-16                   |
| 4A1A1CR4              | 7-27-29                   | 4A1A1U3               | 7-27-22                   | 5A1J1                 | 7-22-18                   |
| 4A1A1CR5              | 7-27-4                    | 4A1J3                 | 7-26-18                   | 5A1J2                 | 7-22-18                   |
| 4A1A1CR6              | 7-27-4                    | 4A1J4                 | 7-26-16                   | 5A1J6                 | 7-22-10                   |
| 4A1A1C1               | 7-27-31                   | 4A1J5                 | 7-26-17                   | 5A1P1                 | 7-22-12                   |
| 4A1A1C2               | 7-27-28                   | 4A1XA1P1              | 7-26-20                   | 5A1P2                 | 7-22-12                   |
| 4A1A1C3               | 7-27-24                   | 4A2                   | 7-24-108                  | 5A2                   | 7-17-4                    |
| 4A1A1C4               | 7-27-28                   | 4A2                   | F7-25-                    | 5A2                   | F7-18-                    |
| 4A1A1C5               | 7-27-33                   | 4A2J1                 | 7-25-3                    | 5A2A1                 | 7-18-20                   |
| 4A1A1C6               | 7-27-17                   | 4A2TB1                | 7-25-4                    | 5A2A1                 | F7-20-                    |
| 4A1A1C7               | 7-27-17                   | 4A2TB2                | 7-25-4                    | 5A2A1CR1              | 7-20-16                   |
| 4A1A1C8               | 7-27-17                   | 4A2TB3                | 7-25-4                    | 5A2A1CR2              | 7-20-16                   |
| 4A1A1C9               | 7-27-17                   | 4CB1                  | 7-25-62                   | 5A2A1CR3              | 7-20-4                    |
| 4A1A1J1               | 7-27-1                    | 5                     | 7- 1-56                   | 5A2A1CR4              | 7-20-7                    |
| 4A1A1J2               | 7-27-1                    | 5                     | F7-17-                    | 5A2A1CR5              | 7-20-48                   |
| 4A1A1J3               | 7-27-18                   | 5A1                   | 7-17-5                    | 5A2A1C1               | 7-20-11                   |
| 4A1A1L1               | 7-27-27                   | 5A1                   | F7-22-                    | 5A2A1C10              | 7-20-11                   |
| 4A1A1Q1               | 7-27-13                   | 5A1A1                 | 7-22-24                   | 5A2A2C11              | 7-20-29                   |
| 4A1A1R1               | 7-27-20                   | 5A1A1                 | F7-23-                    | 5A2A1C13              | 7-20-30                   |
| 4A1A1R10              | 7-27-32                   | 5A1A1CR1              | 7-23-3                    | 5A2A1C16              | 7-20-11                   |
| 4A1A1R11              | 7-27-10                   | 5A1A1CR2              | 7-23-3                    | 5A2A1C17              | 7-20-28                   |
| 4A1A1R12              | 7-27-9                    | 5A1A1CR3              | 7-23-3                    | 5A2A1C18              | 7-20-38                   |
| 4A1A1R13              | 7-27-11                   | 5A1A1CR4              | 7-23-3                    | 5A2A1C19              | 7-20-11                   |
| 4A1A1R14              | 7-27-35                   | 5A1A1CR5              | 7-23-14                   | 5A2A1C2               | 7-20-51                   |
| 4A1A1R15              | 7-27-6                    | 5A1A1C1               | 7-23-7                    | 5A2A1C20              | 7-20-29                   |
| 4A1A1R16              | 7-27-15                   | 5A1A1C2               | 7-23-7                    | 5A2A1C22              | 7-20-30                   |
| 4A1A1R17              | 7-27-8                    | 5A1A1C3               | 7-23-7                    | 5A2A1C25              | 7-20-38                   |
| 4A1A1R18              | 7-27-12                   | 5A1A1C4               | 7-23-7                    | 5A2A1C26              | 7-20-11                   |
| 4A1A1R19              | 7-27-6                    | 5A1A1C5               | 7-23-7                    | 5A2A1C3               | 7-20-51                   |
| 4A1A1R2               | 7-27-20                   | 5A1A1J1               | 7-23-4                    | 5A2A1C7               | 7-20-11                   |
| 4A1A1R20              | 7-27-7                    | 5A1A1Q1               | 7-23-15                   | 5A2A1C8               | 7-20-28                   |
| 4A1A1R21              | 7-27-20                   | 5A1A1Q2               | 7-23-9                    | 5A2A1C9               | 7-20-38                   |
| 4A1A1R22              | 7-27-6                    | 5A1A1Q3               | 7-23-9                    | 5A2A1DS1              | 7-20-65                   |

## Section IV. REFERENCE DESIGNATION INDEX - Continued

| REFERENCE DESIGNATION | VOLUME FIGURE & INDEX NO. | REFERENCE DESIGNATION | VOLUME FIGURE & INDEX NO. | REFERENCE DESIGNATION | VOLUME FIGURE & INDEX NO. |
|-----------------------|---------------------------|-----------------------|---------------------------|-----------------------|---------------------------|
| 5A2A1DS2              | 7-20-67                   | 5A2A1R37              | 7-20-18                   | 5A2A1U10              | 7-20-31                   |
| 5A2A1DS3              | 7-20-66                   | 5A2A1R38              | 7-20-18                   | 5A2A1U11              | 7-20-43                   |
| 5A2A1DS4              | 7-20-66                   | 5A2A1R39              | 7-20-18                   | 5A2A1U12              | 7-20-43                   |
| 5A2A1DS5              | 7-20-73                   | 5A2A1R4               | 7-20-19                   | 5A2A1U13              | 7-20-53                   |
| 5A2A1DS6              | 7-20-73                   | 5A2A1R45              | 7-20-26                   | 5A2A1U14              | 7-20-58                   |
| 5A2A1DS7              | 7-20-73                   | 5A2A1R5               | 7-20-18                   | 5A2A1U15              | 7-20-26                   |
| 5A2A1DS8              | 7-20-73                   | 5A2A1R6               | 7-20-20                   | 5A2A1U16              | 7-20-52                   |
| 5A2A1HR1              | 7-20-72                   | 5A2A1R7               | 7-20-20                   | 5A2A1U17              | 7-20-54                   |
| 5A2A1HR2              | 7-20-72                   | 5A2A1R8               | 7-20-6                    | 5A2A1U18              | 7-20-60                   |
| 5A2A1HR3              | 7-20-72                   | 5A2A1R9               | 7-20-49                   | 5A2A1U19              | 7-20-41                   |
| 5A2A1HR4              | 7-20-72                   | 5A2A1TP1              | 7-20-61                   | 5A2A1U2               | 7-20-3                    |
| 5A2A1J1               | 7-20-40                   | 5A2A1TP10             | 7-20-12                   | 5A2A1U20              | 7-20-57                   |
| 5A2A1J2               | 7-20-39                   | 5A2A1TP11             | 7-20-55                   | 5A2A1U21              | 7-20-37                   |
| 5A2A1J3               | 7-20-39                   | 5A2A1TP12             | 7-20-55                   | 5A2A1U22              | 7-20-56                   |
| 5A2A1J5               | 7-20-2                    | 5A2A1TP13             | 7-20-55                   | 5A2A1U24              | 7-20-59                   |
| 5A2A1J6               | 7-20-2                    | 5A2A1TP14             | 7-20-55                   | 5A2A1U26              | 7-20-59                   |
| 5A2A1J7               | 7-20-2                    | 5A2A1TP15             | 7-20-55                   | 5A2A1U27              | 7-20-34                   |
| 5A2A1J8               | 7-20-2                    | 5A2A1TP16             | 7-20-1                    | 5A2A1U28              | 7-20-34                   |
| 5A2A1L1               | 7-20-50                   | 5A2A1TP17             | 7-20-33                   | 5A2A1U29              | 7-20-35                   |
| 5A2A1Q2               | 7-20-14                   | 5A2A1TP18             | 7-20-33                   | 5A2A1U3               | 7-20-3                    |
| 5A2A1Q3               | 7-20-14                   | 5A2A1TP19             | 7-20-33                   | 5A2A1U30              | 7-20-35                   |
| 5A2A1R1               | 7-20-17                   | 5A2A1TP2              | 7-20-61                   | 5A2A1U31              | 7-20-42                   |
| 5A2A1R10              | 7-20-10                   | 5A2A1TP20             | 7-20-33                   | 5A2A1U33              | 7-20-41                   |
| 5A2A1R11              | 7-20-9                    | 5A2A1TP21             | 7-20-33                   | 5A2A1U34              | 7-20-31                   |
| 5A2A1R12              | 7-20-6                    | 5A2A1TP22             | 7-20-12                   | 5A2A1U35              | 7-20-36                   |
| 5A2A1R13              | 7-20-8                    | 5A2A1TP23             | 7-20-12                   | 5A2A1U36              | 7-20-37                   |
| 5A2A1R14              | 7-20-18                   | 5A2A1TP25             | 7-20-12                   | 5A2A1U37              | 7-20-62                   |
| 5A2A1R15              | 7-20-24                   | 5A2A1TP26             | 7-20-33                   | 5A2A1U38              | 7-20-31                   |
| 5A2A1R17              | 7-20-25                   | 5A2A1TP27             | 7-20-12                   | 5A2A1U39              | 7-20-37                   |
| 5A2A1R18              | 7-20-25                   | 5A2A1TP28             | 7-20-33                   | 5A2A1U4               | 7-20-3                    |
| 5A2A1R19              | 7-20-25                   | 5A2A1TP29             | 7-20-1                    | 5A2A1U40              | 7-20-63                   |
| 5A2A1R2               | 7-20-17                   | 5A2A1TP3              | 7-20-61                   | 5A2A1U41              | 7-20-32                   |
| 5A2A1R21              | 7-20-18                   | 5A2A1TP30             | 7-20-12                   | 5A2A1U42              | 7-20-26                   |
| 5A2A1R22              | 7-20-18                   | 5A2A1TP31             | 7-20-1                    | 5A2A1U44              | 7-20-27                   |
| 5A2A1R25              | 7-20-25                   | 5A2A1TP32             | 7-20-1                    | 5A2A1U5               | 7-20-3                    |
| 5A2A1R27              | 7-20-25                   | 5A2A1TP33             | 7-20-12                   | 5A2A1U8               | 7-20-13                   |
| 5A2A1R28              | 7-20-18                   | 5A2A1TP34             | 7-20-1                    | 5A2A1U9               | 7-20-23                   |
| 5A2A1R29              | 7-20-22                   | 5A2A1TP35             | 7-20-1                    | 5A2A1XDS1             | 7-20-71                   |
| 5A2A1R3               | 7-20-21                   | 5A2A1TP36             | 7-20-12                   | 5A2A1XDS2             | 7-20-71                   |
| 5A2A1R30              | 7-20-47                   | 5A2A1TP4              | 7-20-61                   | 5A2A1XDS3             | 7-20-71                   |
| 5A2A1R31              | 7-20-47                   | 5A2A1TP6              | 7-20-61                   | 5A2A1XDS4             | 7-20-71                   |
| 5A2A1R32              | 7-20-18                   | 5A2A1TP7              | 7-20-61                   | 5A2A1XDS5             | 7-20-74                   |
| 5A2A1R33              | 7-20-25                   | 5A2A1TP8              | 7-20-61                   | 5A2A1XDS6             | 7-20-74                   |
| 5A2A1R34              | 7-20-18                   | 5A2A1TP9              | 7-20-12                   | 5A2A1XDS7             | 7-20-74                   |
| 5A2A1R35              | 7-20-25                   | 5A2A1U1               | 7-20-3                    | 5A2A1XDS8             | 7-20-74                   |

## Section IV. REFERENCE DESIGNATION INDEX - Continued

| REFERENCE DESIGNATION | VOLUME FIGURE & INDEX NO. | REFERENCE DESIGNATION | VOLUME FIGURE & INDEX NO. | REFERENCE DESIGNATION | VOLUME FIGURE & INDEX NO. |
|-----------------------|---------------------------|-----------------------|---------------------------|-----------------------|---------------------------|
| 5A2A2                 | 7-18-19                   | 5A2A2C17              | 7-19-7                    | 5A2A2C61              | 7-19-47                   |
| 5A2A2CR10             | 7-19-2                    | 5A2A2C18              | 7-19-12                   | 5A2A2C66              | 7-19-12                   |
| 5A2A2CR11             | 7-19-2                    | 5A2A2C20              | 7-19-7                    | 5A2A2C68              | 7-19-21                   |
| 5A2A2CR12             | 7-19-10                   | 5A2A2C200             | 7-19-38                   | 5A2A2C69              | 7-19-7                    |
| 5A2A2CR13             | 7-19-2                    | 5A2A2C201             | 7-19-38                   | 5A2A2C7               | 7-19-36                   |
| 5A2A2CR14             | 7-19-71                   | 5A2A2C202             | 7-19-28                   | 5A2A2C70              | 7-19-7                    |
| 5A2A2CR5              | 7-19-71                   | 5A2A2C203             | 7-19-28                   | 5A2A2C71              | 7-19-7                    |
| 5A2A2CR6              | 7-19-2                    | 5A2A2C204             | 7-19-8                    | 5A2A2C72              | 7-19-7                    |
| 5A2A2CR7              | 7-19-2                    | 5A2A2C21              | 7-19-6                    | 5A2A2C73              | 7-19-38                   |
| 5A2A2CR8              | 7-19-2                    | 5A2A2C22              | 7-19-7                    | 5A2A2C74              | 7-19-47                   |
| 5A2A2CR9              | 7-19-2                    | 5A2A2C23              | 7-19-21                   | 5A2A2C76              | 7-19-12                   |
| 5A2A2C1               | 7-19-12                   | 5A2A2C24              | 7-19-36                   | 5A2A2C78              | 7-19-21                   |
| 5A2A2C10              | 7-19-36                   | 5A2A2C25              | 7-19-52                   | 5A2A2C79              | 7-19-7                    |
| 5A2A2C100             | 7-19-36                   | 5A2A2C26              | 7-19-49                   | 5A2A2C8               | 7-19-52                   |
| 5A2A2C101             | 7-19-36                   | 5A2A2C27              | 7-19-36                   | 5A2A2C80              | 7-19-7                    |
| 5A2A2C102             | 7-19-36                   | 5A2A2C28              | 7-19-8                    | 5A2A2C82              | 7-19-7                    |
| 5A2A2C103             | 7-19-12                   | 5A2A2C29              | 7-19-7                    | 5A2A2C83              | 7-19-38                   |
| 5A2A2C105             | 7-19-12                   | 5A2A2C3               | 7-19-7                    | 5A2A2C84              | 7-19-47                   |
| 5A2A2C106             | 7-19-7                    | 5A2A2C30              | 7-19-62                   | 5A2A2C87              | 7-19-12                   |
| 5A2A2C107             | 7-19-12                   | 5A2A2C31              | 7-19-56                   | 5A2A2C88              | 7-19-21                   |
| 5A2A2C108             | 7-19-12                   | 5A2A2C32              | 7-19-7                    | 5A2A2C89              | 7-19-7                    |
| 5A2A2C11              | 7-19-36                   | 5A2A2C33              | 7-19-36                   | 5A2A2C90              | 7-19-7                    |
| 5A2A2C110             | 7-19-12                   | 5A2A2C35              | 7-19-49                   | 5A2A2C91              | 7-19-7                    |
| 5A2A2C111             | 7-19-12                   | 5A2A2C36              | 7-19-12                   | 5A2A2C92              | 7-19-7                    |
| 5A2A2C112             | 7-19-7                    | 5A2A2C38              | 7-19-12                   | 5A2A2C93              | 7-19-38                   |
| 5A2A2C113             | 7-19-36                   | 5A2A2C39              | 7-19-12                   | 5A2A2C94              | 7-19-47                   |
| 5A2A2C114             | 7-19-36                   | 5A2A2C4               | 7-19-7                    | 5A2A2C97              | 7-19-36                   |
| 5A2A2C115             | 7-19-7                    | 5A2A2C42              | 7-19-12                   | 5A2A2C98              | 7-19-36                   |
| 5A2A2C116             | 7-19-12                   | 5A2A2C44              | 7-19-12                   | 5A2A2C99              | 7-19-36                   |
| 5A2A2C117             | 7-19-12                   | 5A2A2C45              | 7-19-21                   | 5A2A2J1               | 7-19-59                   |
| 5A2A2C12              | 7-19-49                   | 5A2A2C46              | 7-19-7                    | 5A2A2J2               | 7-19-59                   |
| 5A2A2C122             | 7-19-7                    | 5A2A2C47              | 7-19-7                    | 5A2A2J3               | 7-19-40                   |
| 5A2A2C124             | 7-19-36                   | 5A2A2C48              | 7-19-7                    | 5A2A2J4               | 7-19-84                   |
| 5A2A2C125             | 7-19-7                    | 5A2A2C49              | 7-19-7                    | 5A2A2J5               | 7-19-32                   |
| 5A2A2C126             | 7-19-36                   | 5A2A2C5               | 7-19-7                    | 5A2A2L13              | 7-19-39                   |
| 5A2A2C128             | 7-19-7                    | 5A2A2C50              | 7-19-38                   | 5A2A2L14              | 7-19-39                   |
| 5A2A2C129             | 7-19-11                   | 5A2A2C51              | 7-19-47                   | 5A2A2L15              | 7-19-19                   |
| 5A2A2C13              | 7-19-8                    | 5A2A2C53              | 7-19-12                   | 5A2A2L6               | 7-19-19                   |
| 5A2A2C131             | 7-19-7                    | 5A2A2C55              | 7-19-21                   | 5A2A2P1               | 7-19-72                   |
| 5A2A2C132             | 7-19-7                    | 5A2A2C56              | 7-19-7                    | 5A2A2P2               | 7-19-72                   |
| 5A2A2C133             | 7-19-12                   | 5A2A2C57              | 7-19-7                    | 5A2A2P3               | 7-19-80                   |
| 5A2A2C138             | 7-19-36                   | 5A2A2C58              | 7-19-7                    | 5A2A2Q11              | 7-19-18                   |
| 5A2A2C14              | 7-19-7                    | 5A2A2C59              | 7-19-7                    | 5A2A2Q12              | 7-19-13                   |
| 5A2A2C15              | 7-19-62                   | 5A2A2C6               | 7-19-21                   | 5A2A2Q13              | 7-19-3                    |
| 5A2A2C16              | 7-19-56                   | 5A2A2C60              | 7-19-38                   | 5A2A2Q14              | 7-19-88                   |

## Section IV. REFERENCE DESIGNATION INDEX - Continued

| REFERENCE DESIGNATION | VOLUME FIGURE & INDEX NO. | REFERENCE DESIGNATION | VOLUME FIGURE & INDEX NO. | REFERENCE DESIGNATION | VOLUME FIGURE & INDEX NO. |
|-----------------------|---------------------------|-----------------------|---------------------------|-----------------------|---------------------------|
| 5A2A2Q4               | 7-19-18                   | 5A2A2R17              | 7-19-54                   | 5A2A2R41              | 7-19-54                   |
| 5A2A2Q7               | 7-19-13                   | 5A2A2R18              | 7-19-54                   | 5A2A2R42              | 7-19-58                   |
| 5A2A2RU20             | 7-19-31                   | 5A2A2R19              | 7-19-58                   | 5A2A2R43              | 7-19-22                   |
| 5A2A2R10              | 7-19-29                   | 5A2A2R2               | 7-19-17                   | 5A2A2R44              | 7-19-60                   |
| 5A2A2R100             | 7-19-17                   | 5A2A2R20              | 7-19-22                   | 5A2A2R47              | 7-19-29                   |
| 5A2A2R101             | 7-19-17                   | 5A2A2R200             | 7-19-29                   | 5A2A2R49              | 7-19-25                   |
| 5A2A2R102             | 7-19-29                   | 5A2A2R201             | 7-19-29                   | 5A2A2R5               | 7-19-32                   |
| 5A2A2R104             | 7-19-32                   | 5A2A2R202             | 7-19-29                   | 5A2A2R50              | 7-19-54                   |
| 5A2A2R106             | 7-19-29                   | 5A2A2R203             | 7-19-29                   | 5A2A2R51              | 7-19-54                   |
| 5A2A2R107             | 7-19-48                   | 5A2A2R204             | 7-19-29                   | 5A2A2R52              | 7-19-17                   |
| 5A2A2R108             | 7-19-46                   | 5A2A2R205             | 7-19-29                   | 5A2A2R53              | 7-19-29                   |
| 5A2A2R109             | 7-19-29                   | 5A2A2R206             | 7-19-29                   | 5A2A2R54              | 7-19-54                   |
| 5A2A2R11              | 7-19-20                   | 5A2A2R207             | 7-19-29                   | 5A2A2R55              | 7-19-32                   |
| 5A2A2R110             | 7-19-23                   | 5A2A2R208             | 7-19-73                   | 5A2A2R56              | 7-19-17                   |
| 5A2A2R111             | 7-19-34                   | 5A2A2R209             | 7-19-73                   | 5A2A2R57              | 7-19-23                   |
| 5A2A2R112             | 7-19-22                   | 5A2A2R21              | 7-19-60                   | 5A2A2R58              | 7-19-34                   |
| 5A2A2R113             | 7-19-32                   | 5A2A2R210             | 7-19-29                   | 5A2A2R59              | 7-19-22                   |
| 5A2A2R114             | 7-19-17                   | 5A2A2R211             | 7-19-17                   | 5A2A2R6               | 7-19-32                   |
| 5A2A2R115             | 7-19-17                   | 5A2A2R212             | 7-19-15                   | 5A2A2R60              | 7-19-32                   |
| 5A2A2R116             | 7-19-29                   | 5A2A2R213             | 7-19-20                   | 5A2A2R61              | 7-19-17                   |
| 5A2A2R118             | 7-19-32                   | 5A2A2R214             | 7-19-16                   | 5A2A2R62              | 7-19-17                   |
| 5A2A2R12              | 7-19-51                   | 5A2A2R217             | 7-19-29                   | 5A2A2R63              | 7-19-29                   |
| 5A2A2R120             | 7-19-29                   | 5A2A2R220             | 7-19-70                   | 5A2A2R65              | 7-19-32                   |
| 5A2A2R121             | 7-19-48                   | 5A2A2R221             | 7-19-50                   | 5A2A2R67              | 7-19-29                   |
| 5A2A2R122             | 7-19-46                   | 5A2A2R222             | 7-19-32                   | 5A2A2R68              | 7-19-48                   |
| 5A2A2R123             | 7-19-29                   | 5A2A2R223             | 7-19-32                   | 5A2A2R69              | 7-19-46                   |
| 5A2A2R129             | 7-19-25                   | 5A2A2R224             | 7-19-32                   | 5A2A2R7               | 7-19-34                   |
| 5A2A2R13              | 7-19-54                   | 5A2A2R25              | 7-19-17                   | 5A2A2R70              | 7-19-23                   |
| 5A2A2R130             | 7-19-26                   | 5A2A2R26              | 7-19-32                   | 5A2A2R71              | 7-19-34                   |
| 5A2A2R131             | 7-19-27                   | 5A2A2R27              | 7-19-17                   | 5A2A2R72              | 7-19-22                   |
| 5A2A2R132             | 7-19-64                   | 5A2A2R28              | 7-19-32                   | 5A2A2R73              | 7-19-32                   |
| 5A2A2R133             | 7-19-25                   | 5A2A2R29              | 7-19-32                   | 5A2A2R74              | 7-19-17                   |
| 5A2A2R134             | 7-19-35                   | 5A2A2R3               | 7-19-32                   | 5A2A2R75              | 7-19-17                   |
| 5A2A2R136             | 7-19-30                   | 5A2A2R30              | 7-19-34                   | 5A2A2R76              | 7-19-29                   |
| 5A2A2R137             | 7-19-41                   | 5A2A2R31              | 7-19-22                   | 5A2A2R78              | 7-19-32                   |
| 5A2A2R138             | 7-19-25                   | 5A2A2R32              | 7-19-23                   | 5A2A2R8               | 7-19-22                   |
| 5A2A2R139             | 7-19-26                   | 5A2A2R33              | 7-19-20                   | 5A2A2R80              | 7-19-29                   |
| 5A2A2R14              | 7-19-53                   | 5A2A2R34              | 7-19-51                   | 5A2A2R81              | 7-19-48                   |
| 5A2A2R140             | 7-19-27                   | 5A2A2R35              | 7-19-54                   | 5A2A2R82              | 7-19-46                   |
| 5A2A2R141             | 7-19-64                   | 5A2A2R36              | 7-19-29                   | 5A2A2R83              | 7-19-23                   |
| 5A2A2R142             | 7-19-25                   | 5A2A2R37              | 7-19-24                   | 5A2A2R84              | 7-19-34                   |
| 5A2A2R143             | 7-19-17                   | 5A2A2R38              | 7-19-50                   | 5A2A2R85              | 7-19-22                   |
| 5A2A2R15              | 7-19-50                   | 5A2A2R39              | 7-19-57                   | 5A2A2R86              | 7-19-32                   |
| 5A2A2R16              | 7-19-57                   | 5A2A2R4               | 7-19-17                   | 5A2A2R87              | 7-19-17                   |
| 5A2A2R164             | 7-19-9                    | 5A2A2R40              | 7-19-54                   | 5A2A2R88              | 7-19-17                   |

## Section IV. REFERENCE DESIGNATION INDEX - Continued

| REFERENCE DESIGNATION | VOLUME FIGURE & INDEX NO. | REFERENCE DESIGNATION | VOLUME FIGURE & INDEX NO. | REFERENCE DESIGNATION | VOLUME FIGURE & INDEX NO. |
|-----------------------|---------------------------|-----------------------|---------------------------|-----------------------|---------------------------|
| 5A2A2R89              | 7-19-29                   | 5A2A2U24              | 7-19-33                   | 5A2S4                 | 7-18-15                   |
| 5A2A2R9               | 7-19-23                   | 5A2A2U25              | 7-19-44                   | 6 SAME AS 5           | 7-1-56                    |
| 5A2A2R91              | 7-19-32                   | 5A2A2U26              | 7-19-33                   | 6A1A4 SAME AS 1A8     |                           |
| 5A2A2R93              | 7-19-29                   | 5A2A2U27              | 7-19-33                   | 7                     | 7-1-57                    |
| 5A2A2R94              | 7-19-48                   | 5A2A2U28              | 7-19-44                   | 8                     | 7- 1-57                   |
| 5A2A2R95              | 7-19-46                   | 5A2A2U29              | 7-19-33                   |                       |                           |
| 5A2A2R96              | 7-19-23                   | 5A2A2U3               | 7-19-55                   |                       |                           |
| 5A2A2R97              | 7-19-34                   | 5A2A2U30              | 7-19-44                   |                       |                           |
| 5A2A2R98              | 7-19-22                   | 5A2A2U31              | 7-19-33                   |                       |                           |
| 5A2A2R99              | 7-19-32                   | 5A2A2U32              | 7-19-31                   |                       |                           |
| 5A2A2TP1              | 7-19-37                   | 5A2A2U33              | 7-19-24                   |                       |                           |
| 5A2A2TP11             | 7-19-37                   | 5A2A2U34              | 7-19-24                   |                       |                           |
| 5A2A2TP12             | 7-19-37                   | 5A2A2U35              | 7-19-63                   |                       |                           |
| 5A2A2TP13             | 7-19-37                   | 5A2A2U36              | 7-19-31                   |                       |                           |
| 5A2A2TP14             | 7-19-37                   | 5A2A2U38              | 7-19-24                   |                       |                           |
| 5A2A2TP15             | 7-19-37                   | 5A2A2U39              | 7-19-65                   |                       |                           |
| 5A2A2TP16             | 7-19-37                   | 5A2A2U4               | 7-19-33                   |                       |                           |
| 5A2A2TP17             | 7-19-37                   | 5A2A2U40              | 7-19-63                   |                       |                           |
| 5A2A2TP18             | 7-19-37                   | 5A2A2U45              | 7-19-85                   |                       |                           |
| 5A2A2TP19             | 7-19-37                   | 5A2A2U46              | 7-19-85                   |                       |                           |
| 5A2A2TP2              | 7-19-37                   | 5A2A2U5               | 7-19-79                   |                       |                           |
| 5A2A2TP20             | 7-19-37                   | 5A2A2U6               | 7-19-55                   |                       |                           |
| 5A2A2TP21             | 7-19-37                   | 5A2A2U7               | 7-19-76                   |                       |                           |
| 5A2A2TP22             | 7-19-37                   | 5A2A2U8               | 7-19-69                   |                       |                           |
| 5A2A2TP3              | 7-19-37                   | 5A2A2U9               | 7-19-68                   |                       |                           |
| 5A2A2TP4              | 7-19-37                   | 5A2J1                 | 7-18-11                   |                       |                           |
| 5A2A2TP6              | 7-19-37                   | 5A2J2                 | 7-18-11                   |                       |                           |
| 5A2A2TP7              | 7-19-37                   | 5A2J3                 | 7-18-11                   |                       |                           |
| 5A2A2TP8              | 7-19-37                   | 5A2J4                 | 7-18-11                   |                       |                           |
| 5A2A2TP9              | 7-19-37                   | 5A2P1                 | 7-18-24                   |                       |                           |
| 5A2A2T1               | 7-19-61                   | 5A2P2                 | 7-18-24                   |                       |                           |
| 5A2A2T2               | 7-19-61                   | 5A2P3                 | 7-18-22                   |                       |                           |
| 5A2A2U1               | 7-19-65                   | 5A2P4                 | 7-18-21                   |                       |                           |
| 5A2A2U10              | 7-19-65                   | 5A2R1                 | 7-18-18                   |                       |                           |
| 5A2A2U11              | 7-19-74                   | 5A2R2                 | 7-18-7                    |                       |                           |
| 5A2A2U12              | 7-19-78                   | 5A2R3                 | 7-18-7                    |                       |                           |
| 5A2A2U13              | 7-19-79                   | 5A2R4                 | 7-18-7                    |                       |                           |
| 5A2A2U16              | 7-19-67                   | 5A2R5                 | 7-18-7                    |                       |                           |
| 5A2A2U17              | 7-19-77                   | 5A2R6                 | 7-18-7                    |                       |                           |
| 5A2A2U18              | 7-19-75                   | 5A2R7                 | 7-18-7                    |                       |                           |
| 5A2A2U19              | 7-19-65                   | 5A2R8                 | 7-18-7                    |                       |                           |
| 5A2A2U2               | 7-19-33                   | 5A2R9                 | 7-18-8                    |                       |                           |
| 5A2A2U21              | 7-19-67                   | 5A2S1                 | 7-18-3                    |                       |                           |
| 5A2AU22               | 7-19-67                   | 5A2S2                 | 7-18-3                    |                       |                           |
| 5A2AU23               | 7-19-66                   | 5A2S3                 | 7-18-15                   |                       |                           |



## INDEX

| Subject                                       | Paragraph<br>Figure, Table,<br>Number |
|---|---------------------------------------|
| A   |                                       |
| Abbreviations .....                           | T1-1                                  |
| Accessory and ancillary equipment .....       | 1-15                                  |
| Antenna systems .....                         | 1-14                                  |
| Assembly packing and unpacking .....          | F3-2                                  |
| Audio interface                               |                                       |
| Theory of operation .....                     | 4-14                                  |
| Audio interface CCA (1) .....                 | F7-4                                  |
| Component location .....                      | F5-3                                  |
| Maintenance .....                             | 5-4,<br>T5-4<br>T5-5                  |
| Schematic diagram .....                       | FO-2                                  |
| Theory of operation .....                     | 4-6                                   |
| Audio interface CCA (2) .....                 | F7-5                                  |
| Component location .....                      | F5-4                                  |
| Maintenance .....                             | 5-5,<br>T5-4,<br>T5-5                 |
| Schematic diagram .....                       | FO-3                                  |
| Theory of operation .....                     | 4-7                                   |
| B   |                                       |
| Backplane assembly .....                      | F7-10                                 |
| Black interface ...See SDU -- Black Interface |                                       |
| C   |                                       |
| Capabilities and limitations .....            | T1-3,<br>1-18                         |
| Case assembly .....                           | F7-22                                 |
| CCA .....                                     | F7-23                                 |
| Circuit diagrams                              |                                       |
| General .....                                 | 6-1                                   |
| Component packing and unpacking .....         | F3-1                                  |
| COMSEC equipment compatibility .....          | 1-16                                  |
| Control signal distribution unit .....        | F7-2                                  |
| CPU (Central Processing Unit)                 |                                       |
| CCA .....                                     | 4-10                                  |
| Printed circuit card assembly .....           | F7-8                                  |
| Schematic diagram .....                       | FO-6                                  |

INDEX

| Subject                                     | Paragraph<br>Figure, Table,<br>Number |
|---|---------------------------------------|
| D   |                                       |
| Theory of operation .....                   | 4-10                                  |
| Definition of terms and abbreviations ..... | T1-1                                  |
| Description and purpose .....               | 1-2                                   |
| Digital interface                           |                                       |
| CCA .....                                   | 4-15                                  |
| CCA block diagram .....                     | F4-12                                 |
| Maintenance .....                           | 5-12                                  |
| Schematic diagram .....                     | FO-10                                 |
| Theory of operation .....                   | 4-15                                  |
| Display Segment Identification .....        | F5-14.1                               |
| Distribution box .....                      | F7-25                                 |
| Bench test setup .....                      | F5-23                                 |
| Component performance tests .....           | T5-22                                 |
| Fault isolation tests .....                 | T5-23                                 |
| Maintenance .....                           | 5-15                                  |
| Wiring list .....                           | T5-24                                 |
| Distribution unit cover .....               | F7-3                                  |
| E   |                                       |
| Electrical equipment chassis .....          | F7-12                                 |
| Maintenance .....                           |                                       |
| Theory of operation .....                   | 4-5                                   |
| Electrical description .....                | 1-3                                   |
| Electrical mounting base .....              | F7-24                                 |
| Equipment mounting rack .....               | 1-6                                   |
| Equipment required but not supplied .....   | 1-20                                  |
| Equipment supplied .....                    | 1-19                                  |
| F   |                                       |
| Fiber optic                                 |                                       |
| Module                                      |                                       |
| Assembly .....                              | 4-12,<br>F7-11                        |
| Assembly maintenance .....                  | 5-7                                   |
| Assembly schematic diagram .....            | FO-8                                  |
| Component location .....                    | F5-8                                  |
| Theory of operation .....                   | 4-12                                  |

## INDEX

| Subject | Paragraph<br>Figure, Table,<br>Number |
|---------|---------------------------------------|
|---------|---------------------------------------|

## F - Continued

|  |                |
|--|----------------|
| <b>Cable</b>                           |                |
| Assembly maintenance .....             | 5-8            |
| Bench test setup .....                 | F5-11          |
| Cleaning Kit (P/N 741889-801) .....    | T5-12          |
| Component performance tests .....      | T5-10          |
| Fault isolation tests .....            | T5-11          |
| OTDR display .....                     | F5-12.1        |
| OTDR test setup, single and dual ..... | F5-12.2        |
| Theory of operation .....              | 4-12           |
| <b>Receiver</b>                        |                |
| Component location .....               | F5-10          |
| <b>Transmitter</b>                     |                |
| Component location .....               | F5-9           |
| <b>FM BITE/Audio</b>                   |                |
| <b>CCA</b>                             |                |
| Bench test setup .....                 | 5-19           |
| Maintenance .....                      | 5-14           |
| <b>Interface</b>                       |                |
| Assembly .....                         | F7-26          |
| Assembly bench test setup .....        | 5-14,<br>F5-19 |
| CCA .....                              | F7-27          |
| Component location .....               | F5-22          |
| Component performance tests .....      | T5-19          |
| Fault isolation tests .....            | T5-20          |
| Maintenance .....                      | 5-13           |
| Schematic diagram .....                | FO-12          |
| Theory of operation .....              | 4-17           |
| Wiring diagram .....                   | F5-21          |
| Wiring list .....                      | T5-21          |

## G

|                           |     |
|---------------------------|-----|
| <b>General</b>            |     |
| Information .....         | 1-1 |
| Theory of operation ..... | 4-2 |

## H

|   |       |
|---|-------|
| Hermaphroditic connector components ..... | F5-12 |
| HF subsystem .....                        | 1-10  |

INDEX

| Subject  | Paragraph<br>Figure, Table,<br>Number |
|--|---------------------------------------|
| I  |                                       |
| Illustrated parts breakdown                          |                                       |
| General .....  | 7-1                                   |
| Maintenance parts list .....                         | 7-2                                   |
| Numerical index .....                                | 7-3                                   |
| Reference designation index .....                    | 7-4                                   |
| Interrupt Priority,                                  |                                       |
| Restart address and sensitivity .....                | T4-2                                  |
| Items requiring special attention .....              | T3-1                                  |
| J  |                                       |
| K  |                                       |
| L  |                                       |
| Leading particulars .....                            | 1-17,<br>T1-2                         |
| M  |                                       |
| Machine cycle status .....                           | T4-1                                  |
| Maintenance ...see listings under name of component. |                                       |
| Mounting plate assembly .....                        | F7-14                                 |
| N  |                                       |
| O  |                                       |
| Operation, theory of ...see Theory of operation.     |                                       |
| P  |                                       |
| Panel Interface                                      |                                       |
| Block diagram .....                                  | F4-15                                 |
| CCA .....  | 4-18                                  |
| Schematic diagram .....                              | F0-18                                 |
| PDU electrical equipment chassis                     |                                       |
| Bench test setup .....                               | F5-24                                 |
| Component location .....                             | F5-25                                 |
| Component performance tests .....                    | T5-25                                 |
| Fault isolation tests .....                          | T5-26                                 |
| Maintenance .....                                    | 5-16                                  |
| Wiring list .....                                    | T5-27                                 |

## INDEX

| Subject  | Paragraph<br>Figure, Table,<br>Number |
|--|---------------------------------------|
| P - Continued  |                                       |
| Performance test checks                                  |                                       |
| General .....  | 5-17                                  |
| PIC block diagram .....                                  | F4-7                                  |
| Physical description .....                               | 1-4                                   |
| Power distribution unit                                  |                                       |
| Schematic diagram .....                                  | FO-1                                  |
| Wiring diagram .....                                     | FO-16                                 |
| Power supply subassembly .....                           | F7-9                                  |
| Power switchboard .....                                  | 1-7,<br>F7-13                         |
| Preparation for use and reshipment                       |                                       |
| General .....  | 3-2                                   |
| Introduction .....                                       | 3-1                                   |
| Preparation for reshipment .....                         | 3-3                                   |
| Q  |                                       |
| R  |                                       |
| Radio communication system AN/GRC-206(V)1 and (V)2 ..... | F1-1,<br>F7-1                         |
| Radio set, AN/URC-113 .....                              | F7-16                                 |
| Radio set control ...see RSC (Radio set control)         |                                       |
| Maintenance .....  | 5-8                                   |
| Theory of operation .....                                | 4-13                                  |
| Radio system .....                                       | 1-5                                   |
| Antennas .....   | F1-3                                  |
| Component location .....                                 | F1-2                                  |
| Simplified block diagram .....                           | F4-1                                  |
| Theory of operation .....                                |                                       |
| Red interface ...see SDU -- Red interface                |                                       |
| Related technical manuals .....                          | 1-22                                  |
| Reshipment ...see Preparation for use and reshipment.    |                                       |
| RSC (Radio set control) .....                            | 1-9,<br>F7-17,<br>F7-18               |
| Audio interface  |                                       |
| CCA bench test setup .....                               | 5-11,<br>F5-13                        |
| Component location .....                                 | F5-15                                 |
| Maintenance .....  | 5-10                                  |
| Schematic diagram .....                                  | FO-9                                  |

INDEX

| Subject   | Paragraph<br>Figure, Table,<br>Number |
|---|---------------------------------------|
| R - Continued                                   |                                       |
| Bench test setup .....                          | 5-10                                  |
| Circuit card assembly (CCA) .....               | F7-19,<br>F7-20                       |
| Component performance tests .....               | T5-13                                 |
| Fault isolation tests .....                     | T5-14                                 |
| Component location .....                        | F5-14                                 |
| Digital interface CCA                           |                                       |
| Bench test setup .....                          | 5-12                                  |
| Component location .....                        | F5-16                                 |
| Maintenance .....                               | 5-11                                  |
| Schematic diagram .....                         | F0-10                                 |
| Front panel wiring diagram .....                | F0-14                                 |
| Keyboard schematic diagram .....                | F4-13                                 |
| Panel .....                                     | F7-21                                 |
| Receive audio block diagram .....               | F4-11                                 |
| Regulator CCA                                   |                                       |
| Bench test setup .....                          | F5-13                                 |
| Component location .....                        | F5-17,<br>F5-18                       |
| Component performance tests .....               | T5-17                                 |
| Fault isolation tests .....                     | T5-18                                 |
| Maintenance .....                               | 5-12                                  |
| Schematic diagram .....                         | F0-11                                 |
| Schematic diagram .....                         | F0-15                                 |
| -SDU communication word format .....            | F4-9                                  |
| Test set EPROM select codes .....               | T5-15                                 |
| Theory of operation .....                       | 4-13                                  |
| Transmit audio block diagram .....              | F4-10                                 |
| Wiring List .....                               | T5-16                                 |
| RT Interface CCA .....                          | 4-20                                  |
| Block diagram .....                             | F4-17                                 |
| Schematic diagram .....                         | F0-20                                 |
| S   |                                       |
| Safety Summary .....                            | i                                     |
| SDU (Signal distribution unit) .....            | 1-8                                   |
| Audio interface (1) and (2) block diagram ..... | F4-2                                  |
| Block interface                                 |                                       |
| Basic mode definitions and bus interface .....  | F4-6                                  |
| CCA block diagram .....                         | F4-5                                  |
| Circuit card assembly .....                     | F7-7                                  |
| Schematic diagram .....                         | F0-5                                  |
| Theory of operation .....                       | 4-9                                   |

## INDEX

| Subject  | Paragraph<br>Figure, Table,<br>Number |
|--|---------------------------------------|
| S - Continued                                  |                                       |
| CCA  |                                       |
| Bench test setup .....                         | F5-2                                  |
| Component performance test .....               | T5-4                                  |
| Fault isolation tests .....                    | T5-5                                  |
| Electrical equipment chassis                   |                                       |
| Bench test setup .....                         | F5-1                                  |
| Component performance tests .....              | T5-1                                  |
| Fault isolation tests .....                    | T5-2                                  |
| Maintenance .....                              | 5-3                                   |
| Wiring list .....                              | T5-3                                  |
| Interface CCA .....                            | 4-19                                  |
| Block diagram .....                            | F4-16                                 |
| Schematic diagram .....                        | FO-19                                 |
| Power supply subassembly .....                 | 4-11                                  |
| Bench test setup .....                         | F5-5                                  |
| Block diagram .....                            | F4-8                                  |
| Component location .....                       | F5-6                                  |
| Component height .....                         | F5-7                                  |
| Component performance tests .....              | T5-6                                  |
| Fault isolation tests .....                    | T5-8                                  |
| Fault isolation voltages .....                 | T5-9                                  |
| Maintenance .....                              | 5-6                                   |
| Performance test voltages .....                | T5-7                                  |
| Schematic diagram .....                        | FO-7                                  |
| Test point voltage checks .....                | T5-8                                  |
| Test set .....                                 | F1-4                                  |
| Red interface CCA block diagram .....          | F4-3                                  |
| Basic mode definitions and bus interface ..... | F4-4                                  |
| Circuit card assembly .....                    | F7-6                                  |
| Schematic diagram .....                        | FO-4                                  |
| Theory of operation .....                      | 4-8                                   |
| Reference designator location .....            | F5-1.1                                |
| Schematic diagram .....                        | FO-13                                 |
| Special  |                                       |
| attention, items requiring .....               | T3-1                                  |
| Tools and test equipment .....                 | 1-21                                  |
| Tools list .....                               | T1-4                                  |
| T  |                                       |
| Terms .....                                    | T1-1                                  |
| Test equipment .....                           | T1-5                                  |
| Theory of operation                            |                                       |

|   |      |
|---|------|
| Audio interface CCA .....                 | 4-14 |
| Black interface CCA .....                 | 4-9  |
| CPU CCA .....                             | 4-10 |
| Detailed theory of operation; scope ..... | 4-4  |
| Digital interface CCA .....               | 4-15 |
| Electrical equipment chassis .....        | 4-5  |
| Fiber optic module assembly .....         | 4-12 |
| FM BITE/audio interface assembly .....    | 4-17 |
| General .....                             | 4-2  |
| Introduction .....                        | 4-1  |
| Radio set control .....                   | 4-13 |
| Radio system functional description ..... | 4-3  |
| Red interface CCA .....                   | 4-8  |
| RSC regulator .....                       | 4-16 |
| SDU audio interface (1) CCA .....         | 4-6  |
| (2) CCA .....                             | 4-7  |
| SDU power supply subassembly .....        | 4-11 |
| Typical packing instructions              |      |
| mechanical items .....                    | F3-3 |
| antennas and cables .....                 | F3-4 |

U

|                        |      |
|------------------------|------|
| UHF-AM subsystem ..... | 1-13 |
|------------------------|------|

V

|                                    |       |
|------------------------------------|-------|
| VHF-AM subsystem .....             | 1-12  |
| VHF BITE panel block diagram ..... | F4-14 |
| VHF-FM subsystem .....             | 1-11  |

W

X

Y

Z



NOTES:

- 1.0 GENERAL:
- 1.1 INTERPRET DRAWING IN ACCORDANCE WITH STANDARDS PRESCRIBED BY DOD-STD-100.
  - 1.2 DATA INCLUDED IN PARENTHESIS, ( ), IS FOR REFERENCE ONLY.
  - 1.3 A NUMBER SIGN (#) FOLLOWING A SIGNAL NAME MEANS THE INVERTED (NOT) FORM OF THE SIGNAL.
- 2.0 SPECIFIC:
- 2.1 UNLESS OTHERWISE SPECIFIED: VOLTAGES ARE DC. DIODES AND/OR TRANSISTORS ARE JANTX TYPE. RESISTANCE VALUES ARE IN OHMS.
  - 2.2 PARTIAL REFERENCE DESIGNATIONS ARE SHOWN: FOR COMPLETE DESIGNATION PREFIX WITH UNIT NUMBER AND SUBASSEMBLY DESIGNATION 2.
  - 2.4 PART NUMBER 616497-903
  - 2.5 REFERENCE: ASSEMBLY NUMBER 812088-801.

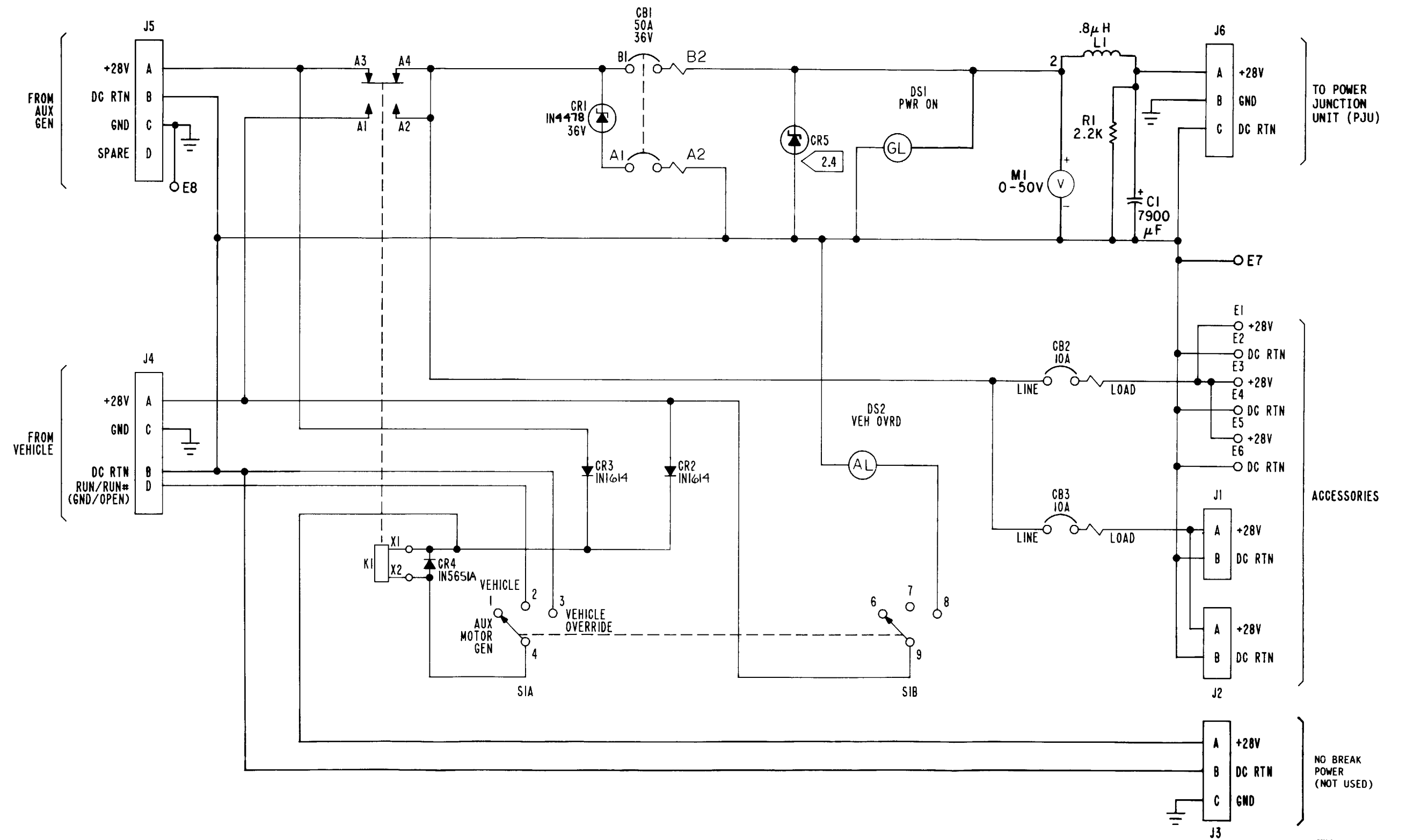

FO-1. Power Distribution Unit Schematic Diagram

MX 61 119-044  
REF MX DWG NO. 483947 REV C



NOTES:

- 1.0 GENERAL:
  - 1.1 INTERPRET DRAWING IN ACCORDANCE WITH STANDARDS PRESCRIBED BY DOD-STD-100.
  - 1.2 DATA INCLUDED IN PARENTHESIS, ( ), IS FOR REFERENCE ONLY.
  - 1.3 A NUMBER SIGN (=) FOLLOWING A SIGNAL NAME MEANS THE INVERTED (NOT) FORM OF THE SIGNAL.
  - 1.4 CHARACTERS UNDERLINED DENOTE LOWER CASE.
- 2.0 SPECIFIC:
  - 2.1 UNLESS OTHERWISE SPECIFIED:
    - RESISTANCE VALUES ARE IN OHMS.
    - RESISTORS ARE 5%, 1/8W.
    - CAPACITANCE VALUES ARE IN MICROFARADS.
    - VOLTAGES ARE DC.
    - DIODES AND/OR TRANSISTORS ARE JANTY TYPE.
  - 2.2 PARTIAL REFERENCE DESIGNATIONS ARE SHOWN: FOR COMPLETE DESIGNATION PREFIX WITH UNIT NUMBER AND SUBASSEMBLY DESIGNATION IAL.
  - 2.3 FOR CONTINUATION OF CIRCUIT SEE SCHEMATIC 493946.
  - 2.4  THIS DEVICE REQUIRES SPECIAL HANDLING AND PROCESSING TO PREVENT DAMAGE FROM ELECTROSTATIC DISCHARGE TRANSIENTS.
  - 2.5 REFERENCE:
    - ASSEMBLY NUMBER 812094-801.
    - PRINTED WIRING BOARD 412039-1.

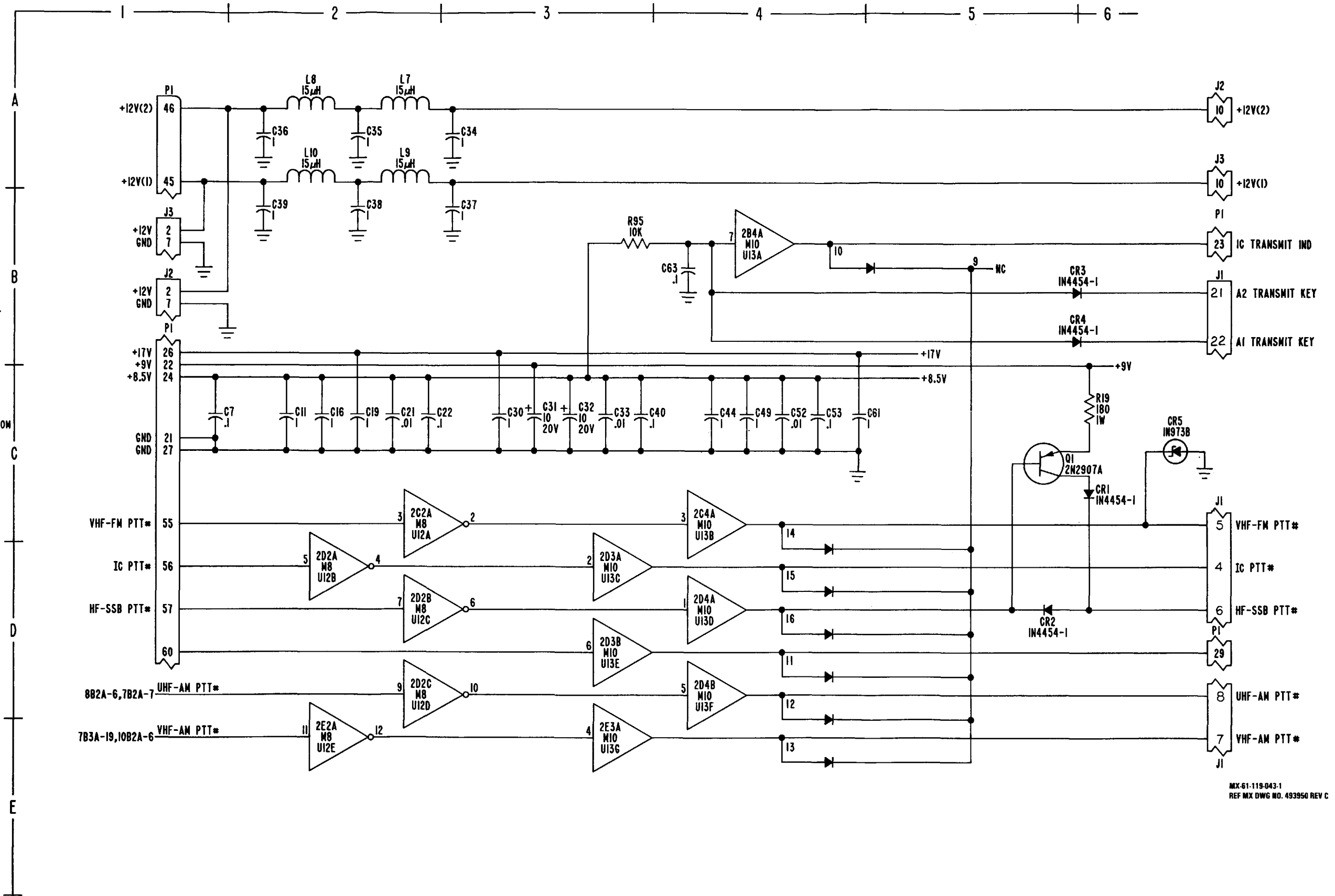
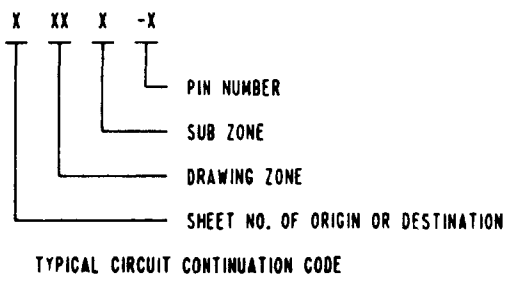

MX-61-119-043-1  
REF MX DWG NO. 493950 REV C

FO-2. SDU Audio Interface (1) Schematic Diagram (Sheet 1 of 9)

FO-3/(FO-4 blank)



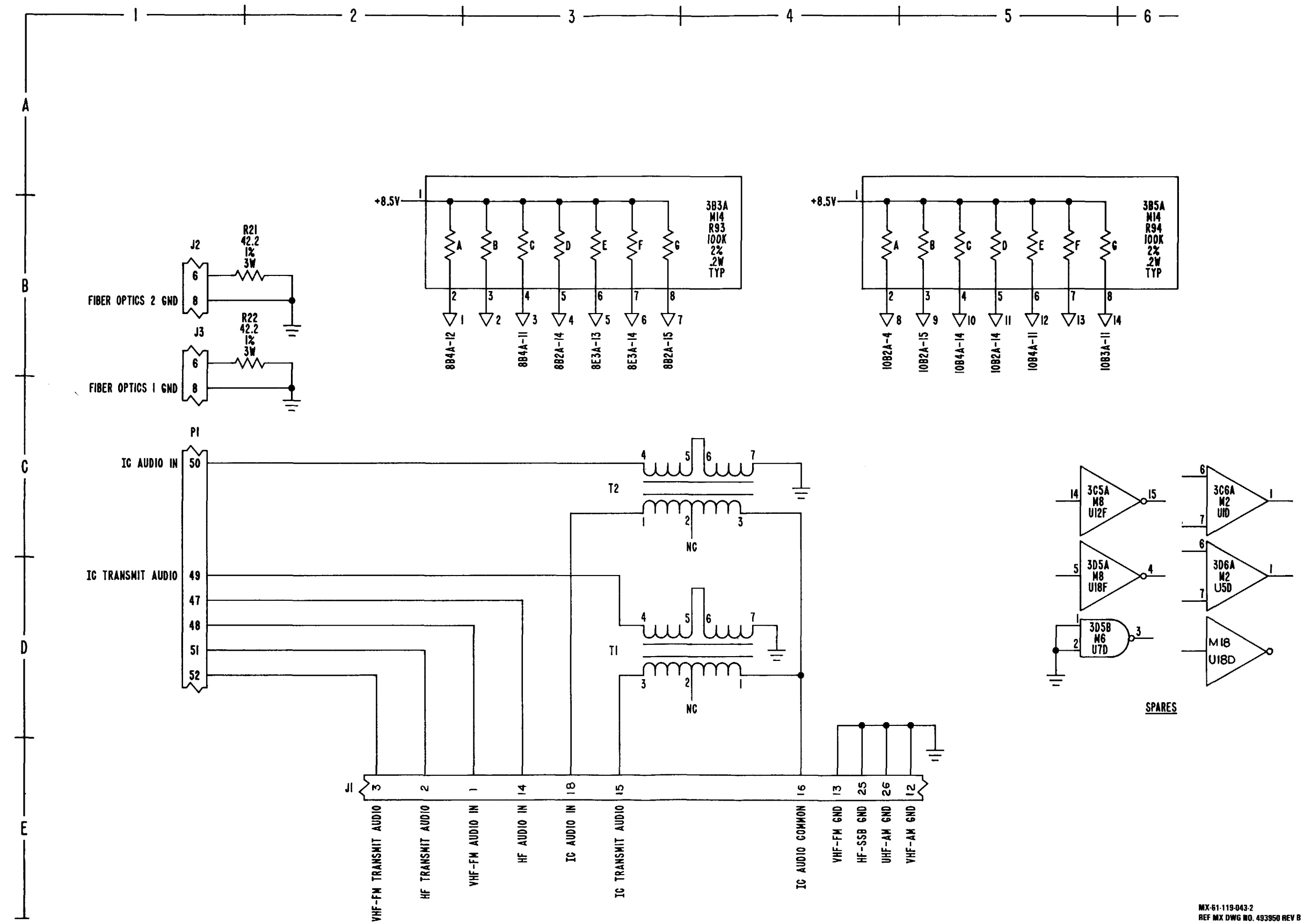

MX-61-119-043-2  
REF MX DWG NO. 493950 REV B

FO-2. SDU Audio Interface (1) Schematic Diagram (Sheet 2 of 9)

FO-5/(FO-6 blank)



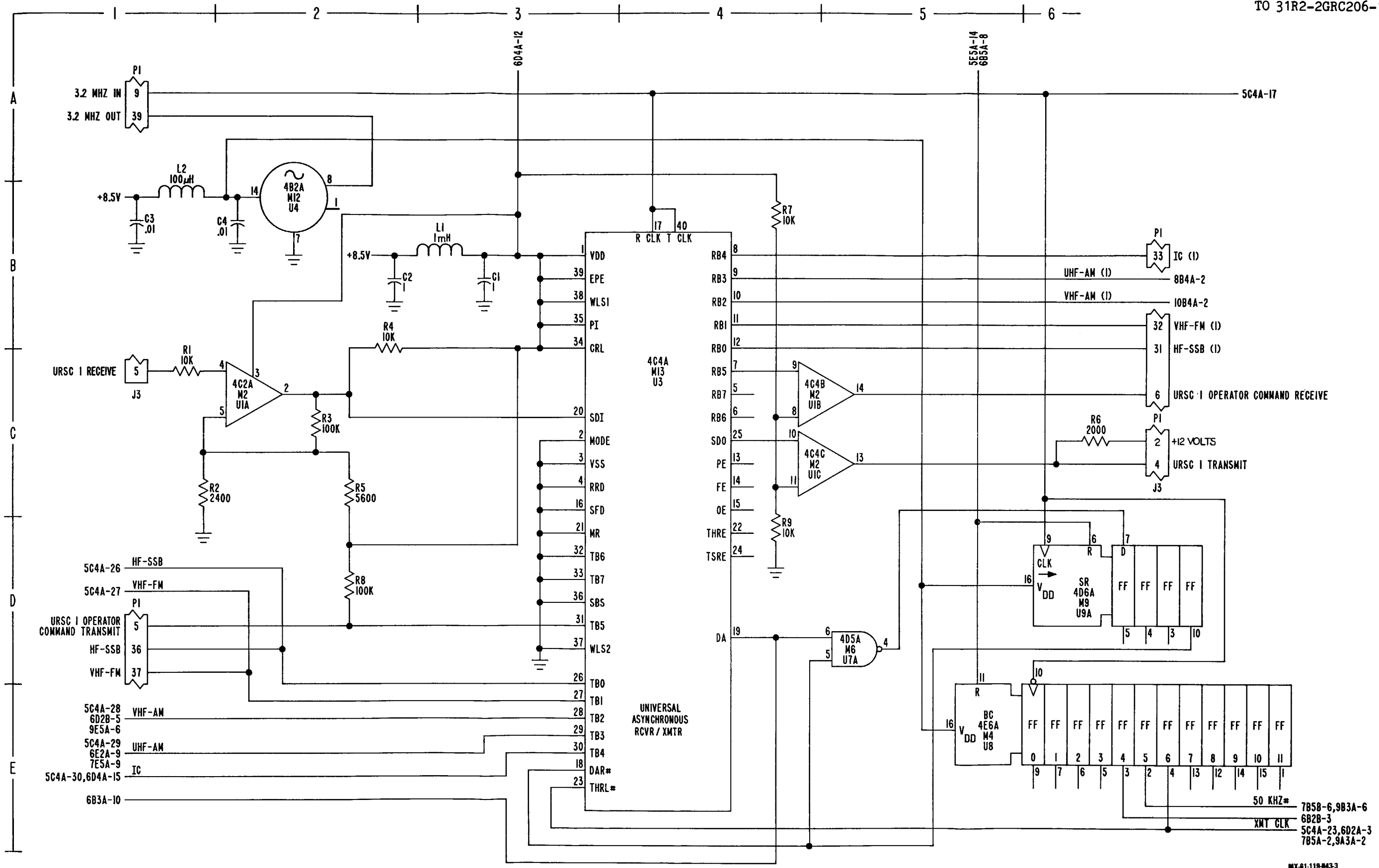

MX-61-119-843-3  
REF MX DWG NO. 483950 REV D

FO-2. SDU Audio Interface (1) Schematic Diagram (Sheet 3 of 9)





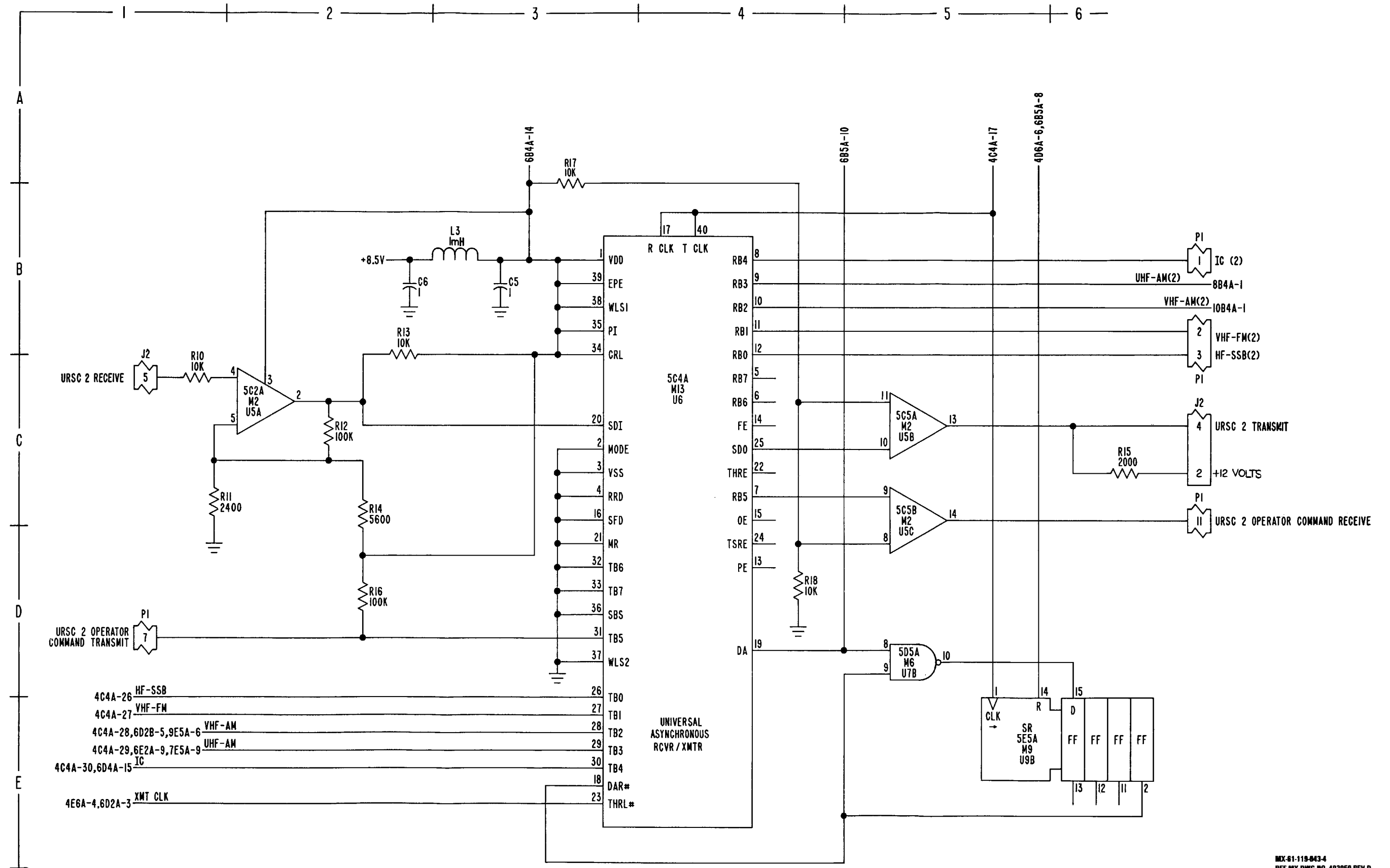

MX-61-119-843-4  
REF MX DWG NO. 493950 REV D

FO-2. SDU Audio Interface (1) Schematic Diagram (Sheet 4 of 9)

FO-9/(FO-10 blank)



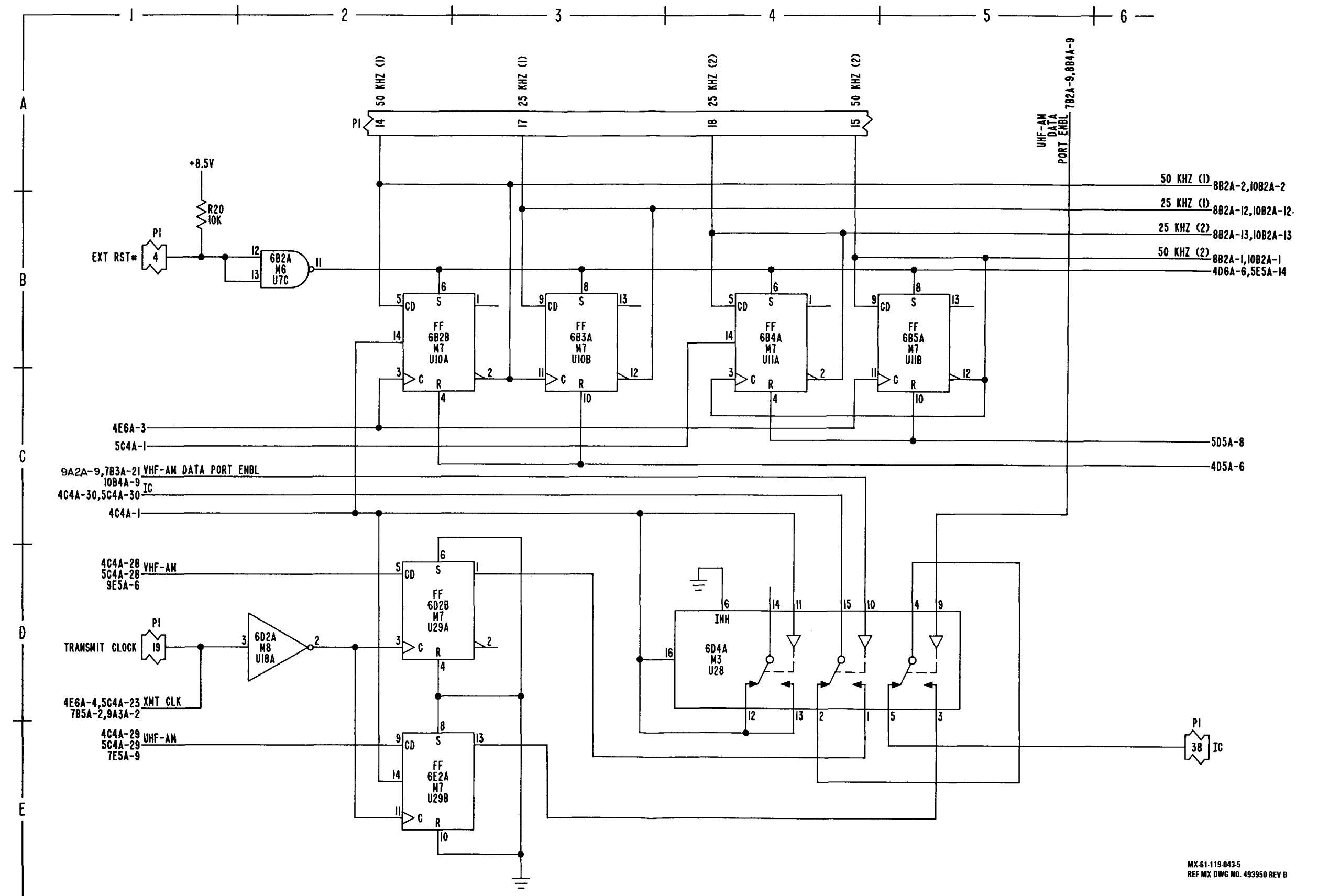

MX-61-119-043-5  
REF MX DWG NO. 493950 REV B

FO-2. SDU Audio Interface (1) Schematic Diagram (Sheet 5 of 9)



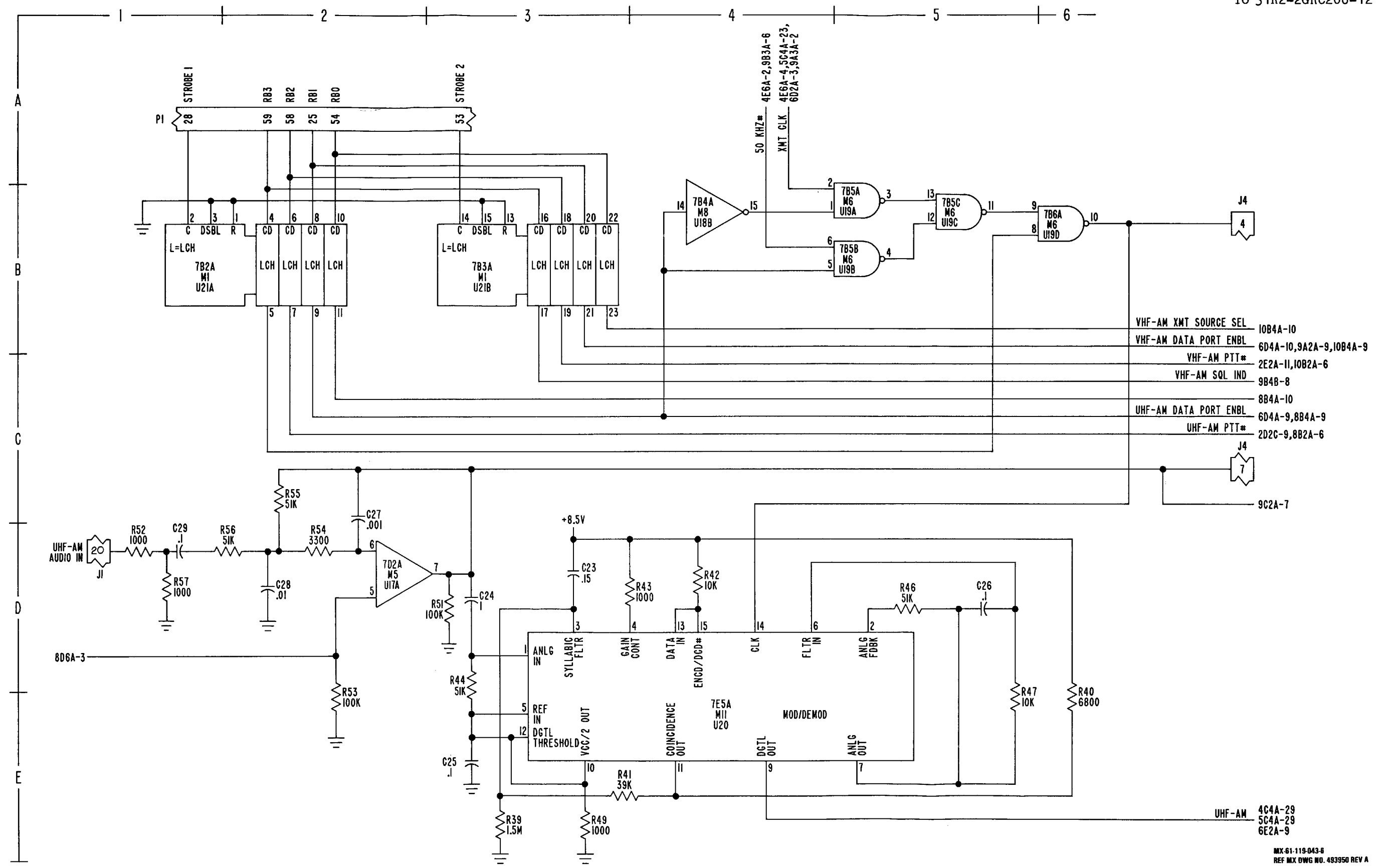

MX-61-119-043-6  
REF MX DWG NO. 493950 REV A

FO-2. SDU Audio Interface (1) Schematic Diagram (Sheet 6 of 9)



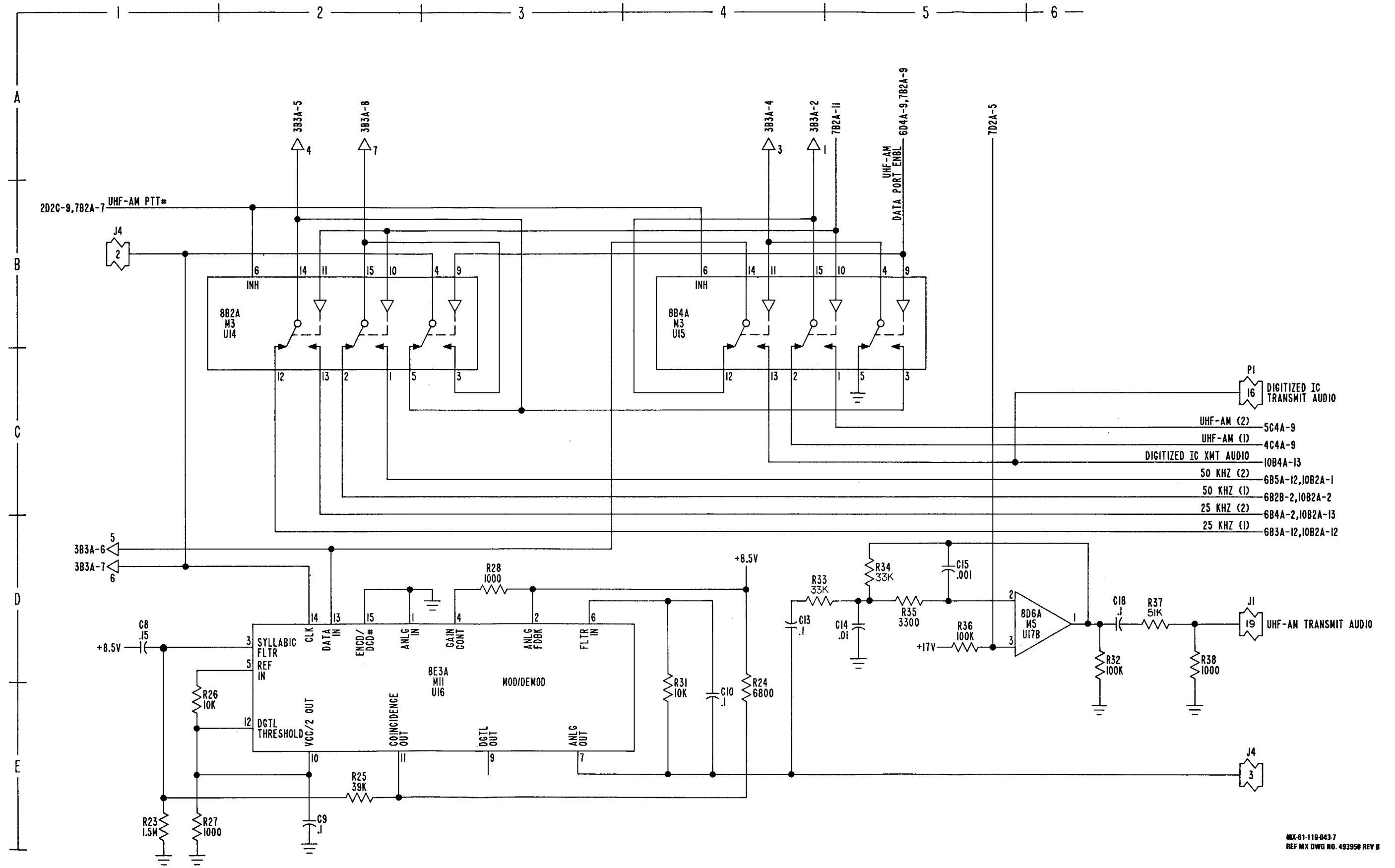

MX-61-119-043-7  
REF MX DWG NO. 493950 REV B

FO-2. SDU Audio Interface (1) Schematic Diagram (Sheet 7 of 9)

FO-15/(FO-16 blank)





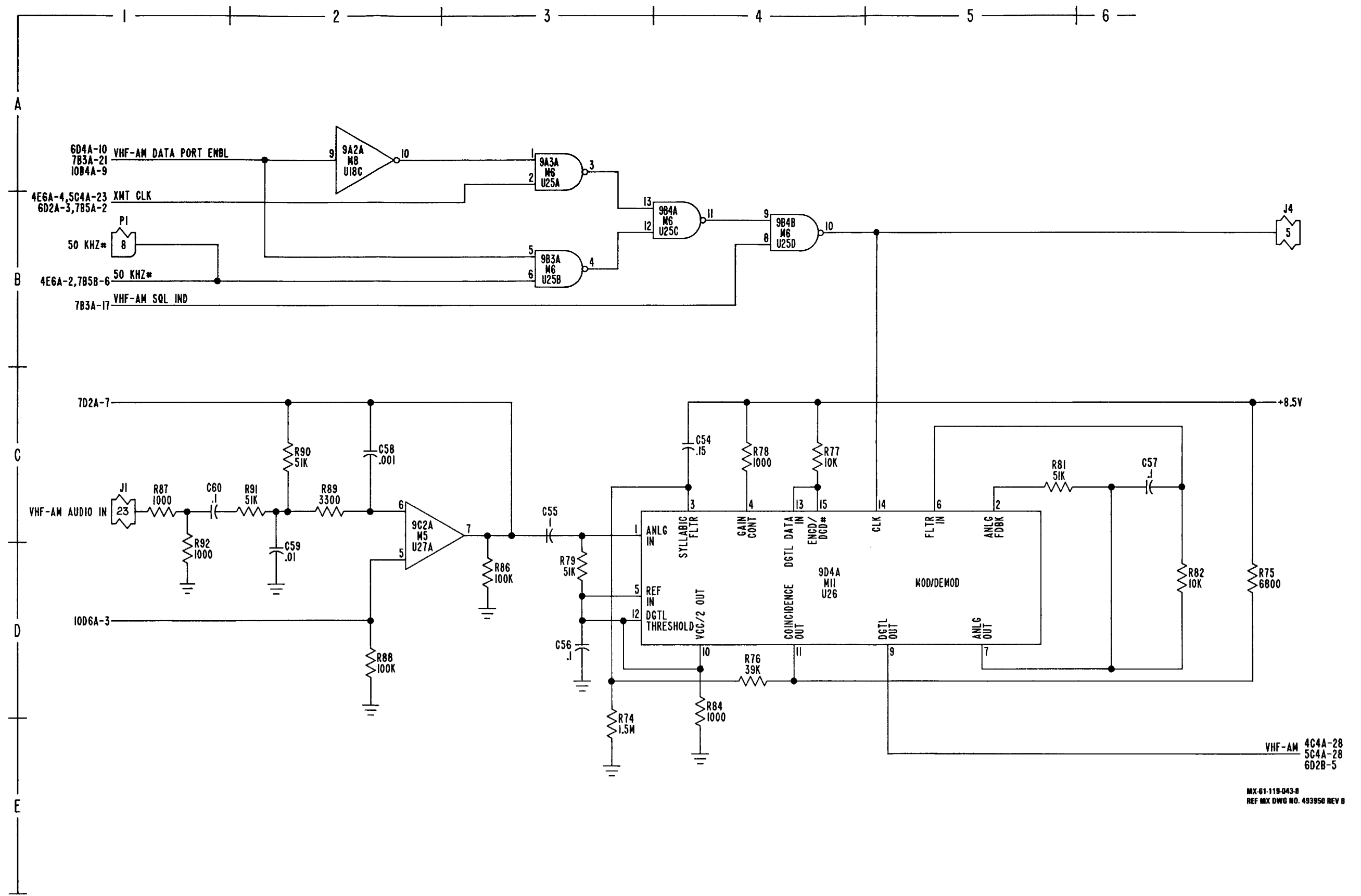

VHF-AM 4C4A-28  
5C4A-28  
6D2B-5  
MX-61-119-043-8  
REF MX DWG NO. 493950 REV B

FO-2. SDU Audio Interface (1) Schematic Diagram (Sheet 8 of 9)



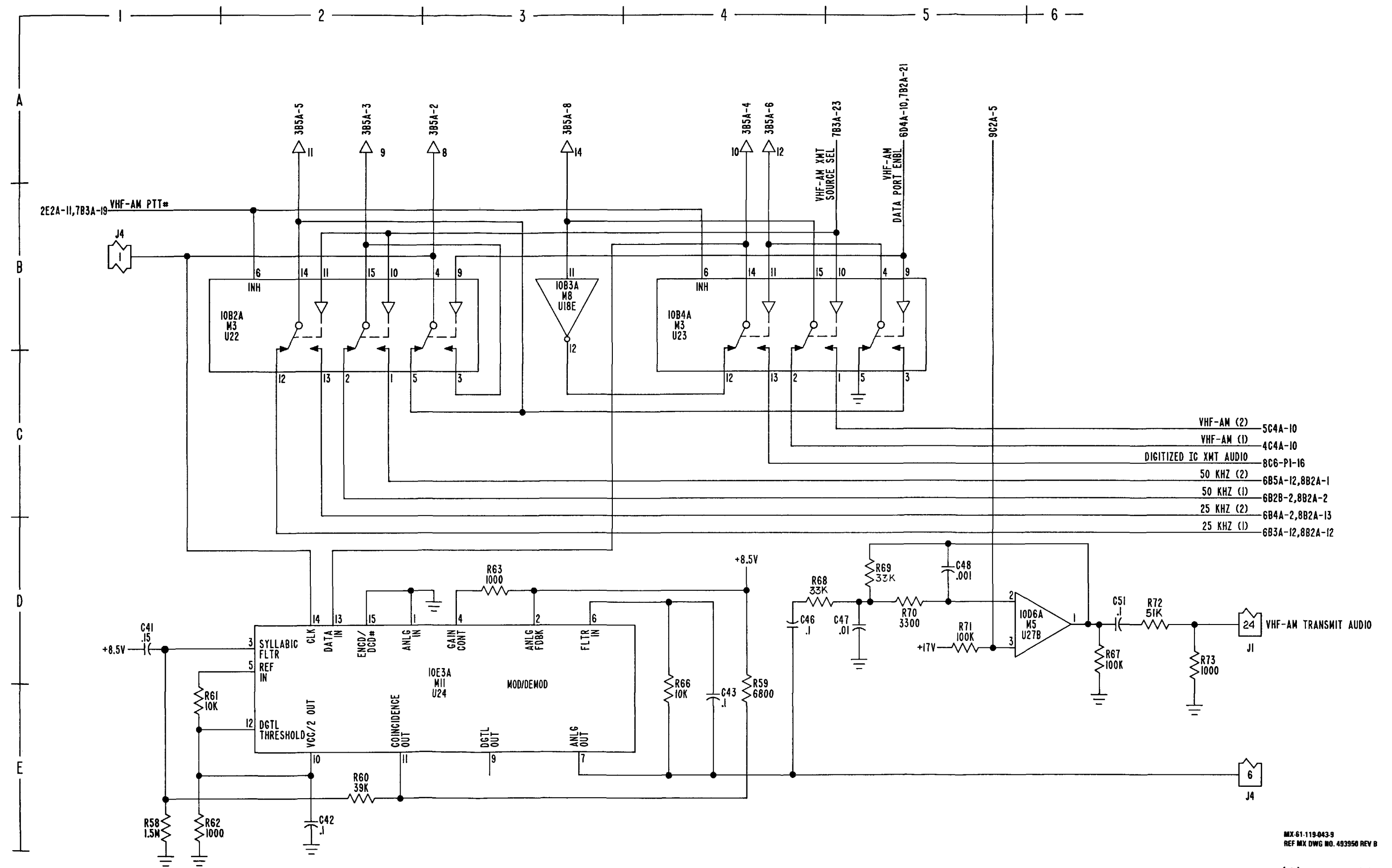

FO-2. SDU Audio Interface (1) Schematic Diagram (Sheet 9 of 9)

MX-61-119-0439  
REF MX DWG NO. 483950 REV B



- 1.0 GENERAL:
- 1.1 INTERPRET DRAWING IN ACCORDANCE WITH STANDARDS PRESCRIBED BY DOD-STD-100.
  - 1.2 DATA INCLUDED IN PARENTHESIS, ( ), IS FOR REFERENCE ONLY.
  - 1.3 A NUMBER SIGN (#) FOLLOWING A SIGNAL NAME MEANS THE INVERTED (NOT) FORM OF THE SIGNAL.
- 2.0 SPECIFIC:
- 2.1 UNLESS OTHERWISE SPECIFIED: RESISTANCE VALUES ARE IN OHMS. RESISTORS ARE 5%, 1/8W. CAPACITANCE VALUES ARE IN MICROFARADS. VOLTAGES ARE DC. DIODES AND/OR TRANSISTORS ARE JANIX TYPE.
  - 2.2 PARTIAL REFERENCE DESIGNATIONS ARE SHOWN: FOR COMPLETE DESIGNATION PREFIX WITH UNIT NUMBER AND SUBASSEMBLY DESIGNATION 1A2.
  - 2.3 FOR CONTINUATION OF CIRCUIT SEE SCHEMATIC 493946.
  - 2.4  THIS DEVICE REQUIRES SPECIAL HANDLING AND PROCESSING TO PREVENT DAMAGE FROM ELECTROSTATIC DISCHARGE TRANSIENTS.
  - 2.5 REFERENCE: ASSEMBLY NUMBER 812095-301. PRINTED WIRING BOARD 412040-1.

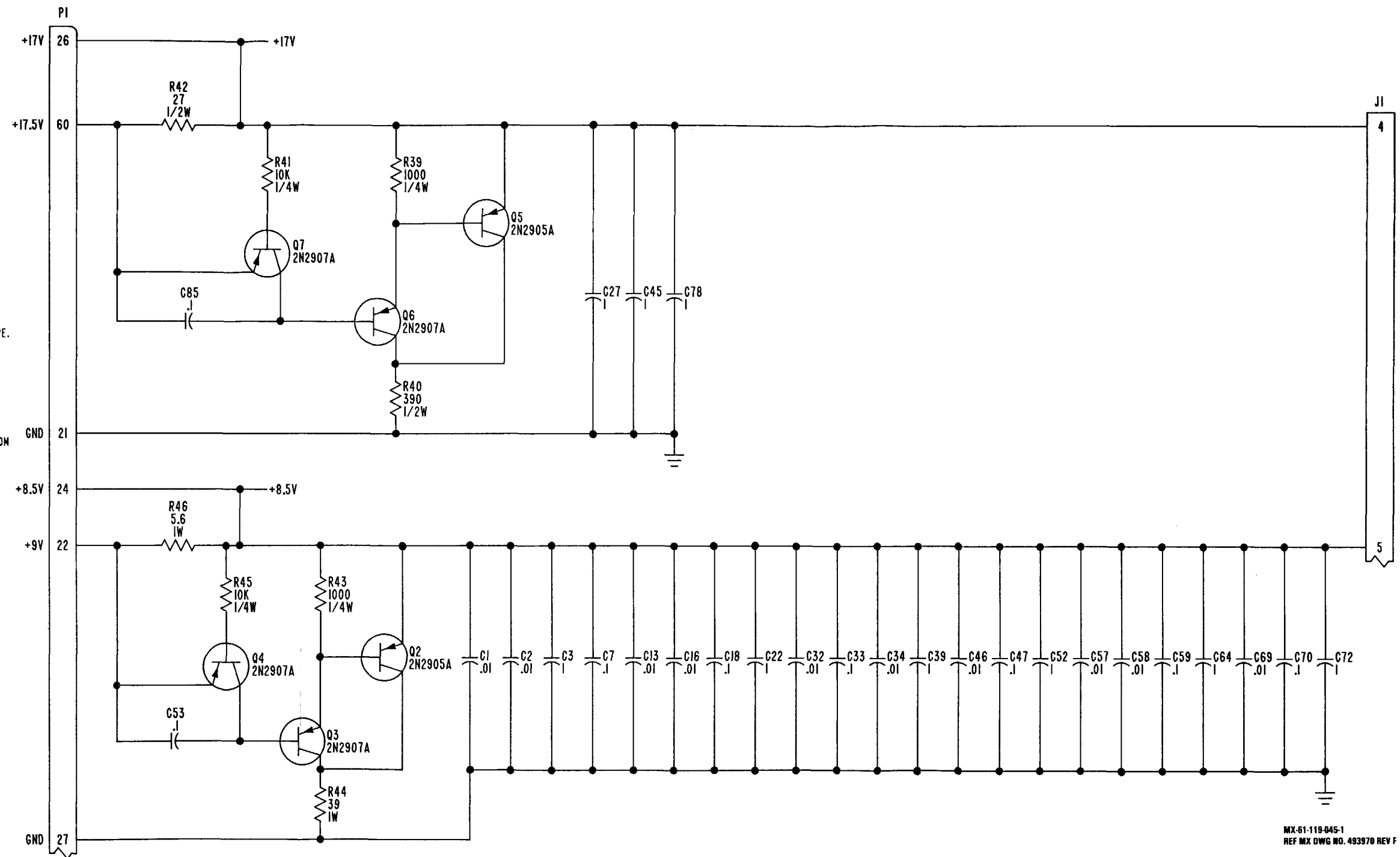
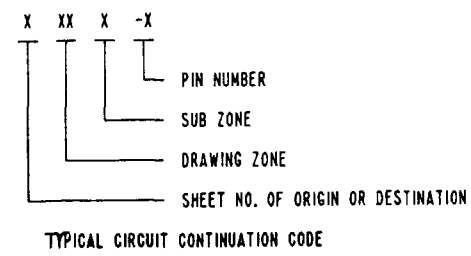

MX-61-119-045-1  
REF MX DWG NO. 493970 REV F



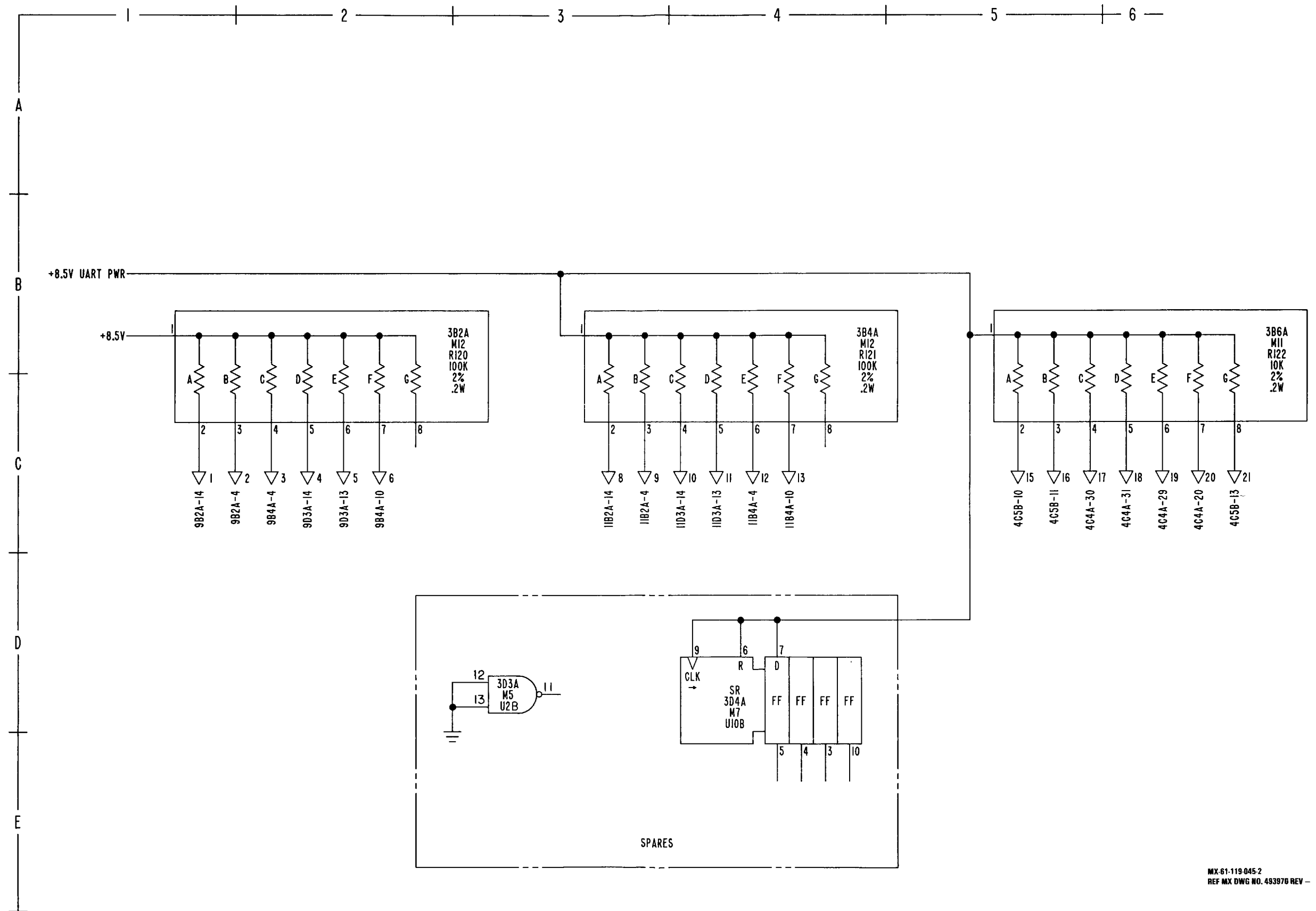

MX-61-119-045-2  
REF MX DWG NO. 493970 REV -

FO-3. SDU Audio Interface (2) Schematic Diagram (Sheet 2 of 11)

FO-23/(FO-24 blank)





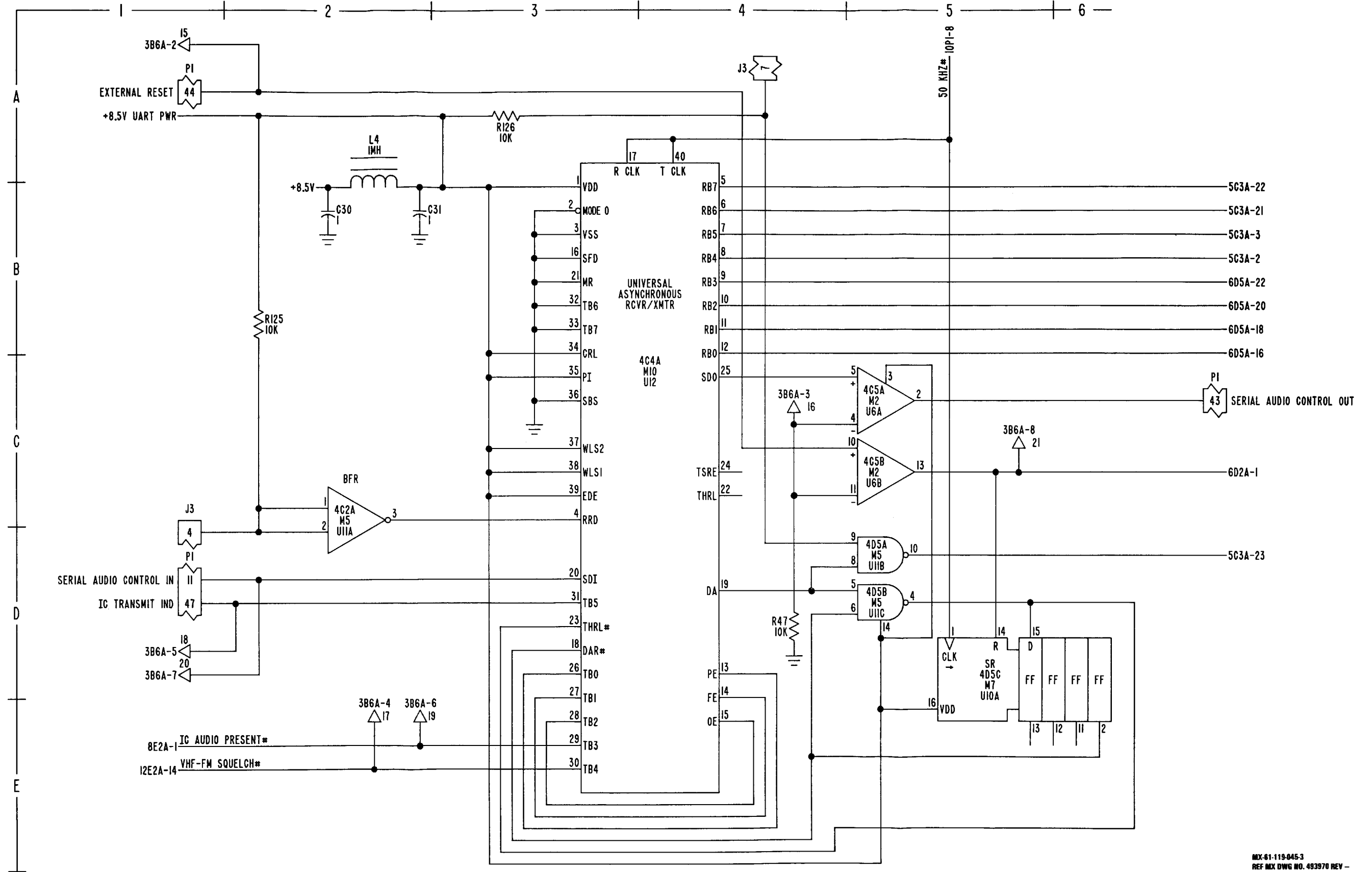

FO-3. SDU Audio Interface (2) Schematic Diagram (Sheet 3 of 11)



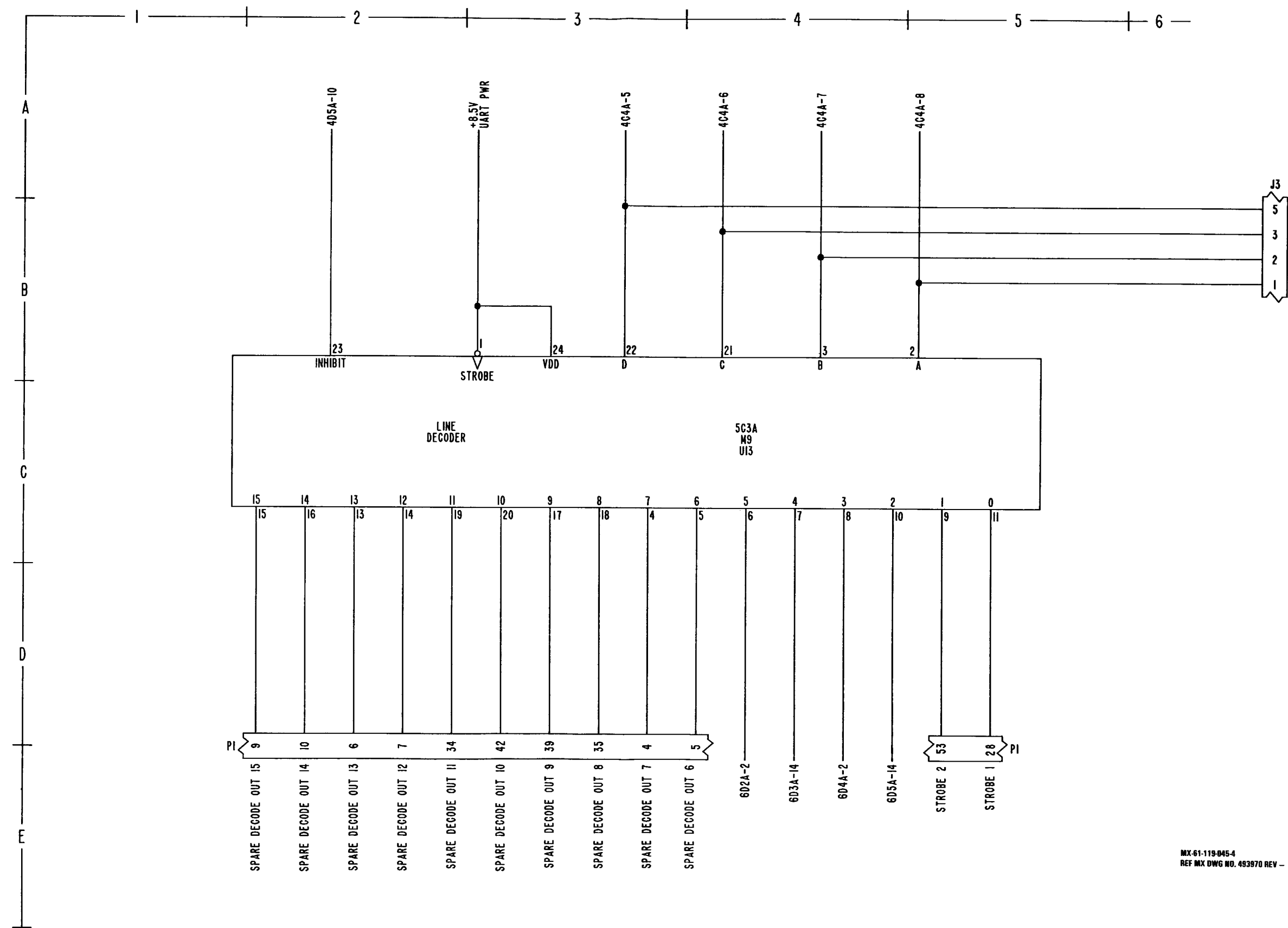

MX-61-119-045-4  
REF MX DWG NO. 483970 REV -

FO-3. SDU Audio Interface (2) Schematic Diagram (Sheet 4 of 11)



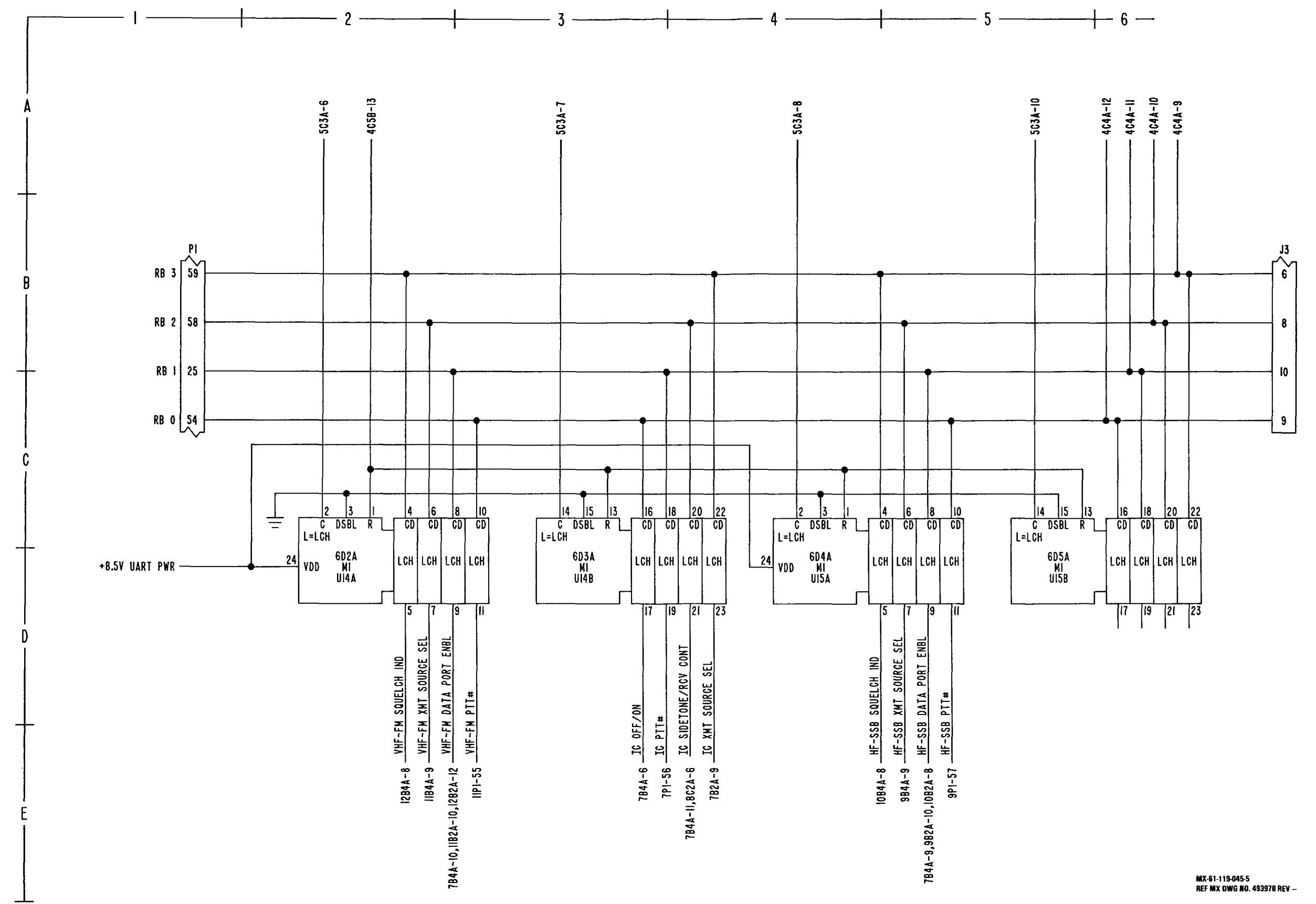

MX 61-119-045-5  
REF MX DWG NO. 493970 REV -

FO-3. SDU Audio Interface (2) Schematic Diagram (Sheet 5 of 11)



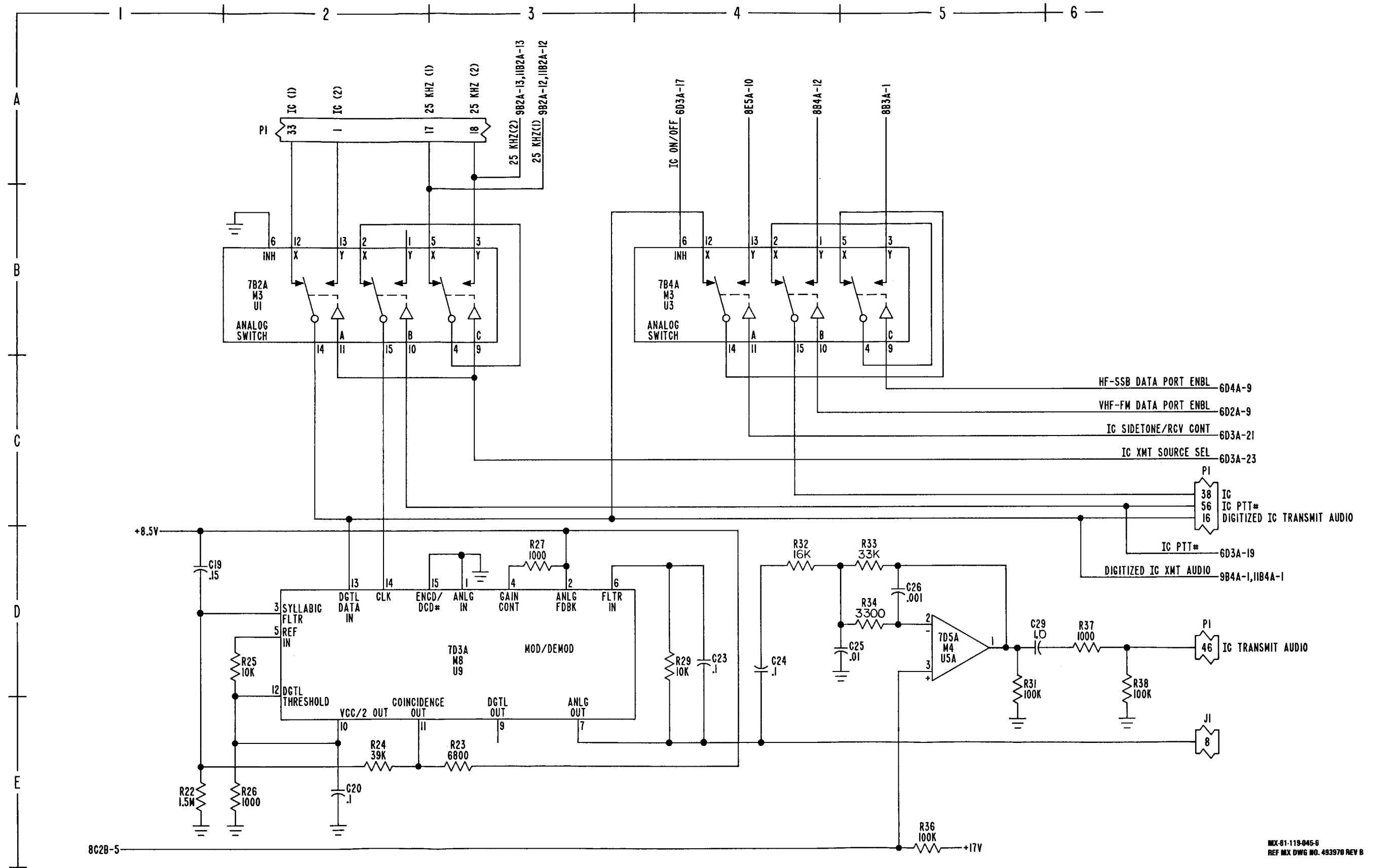

FO-3. SDU Audio Interface (2) Schematic Diagram (Sheet 6 of 11)

MX-91-119-045-6  
REF MX DWG NO. 493970 REV B





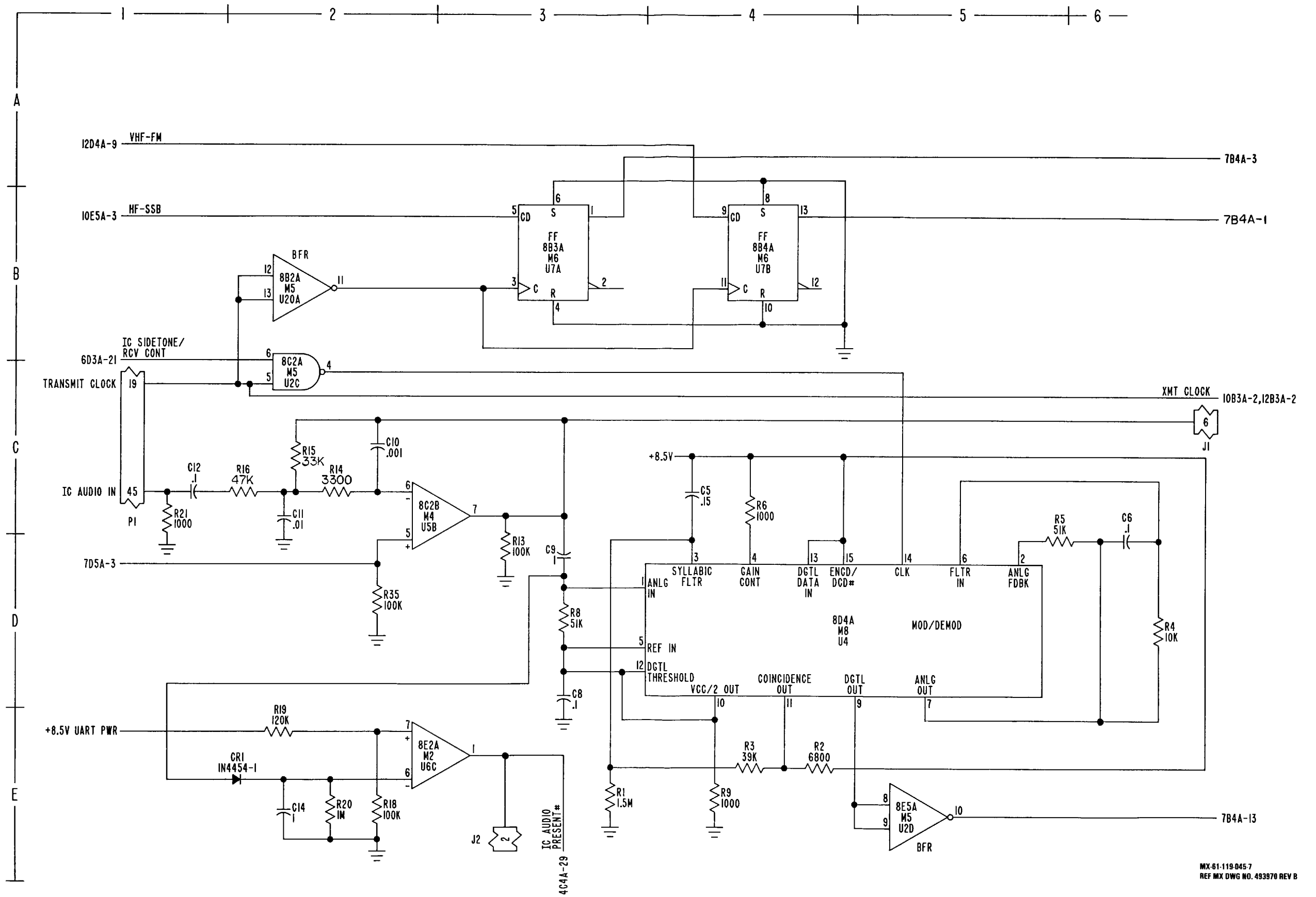

MX-61-119-0457  
REF MX DWG NO. 483970 REV B

FO-3. SDU Audio Interface (2) Schematic Diagram (Sheet 7 of 11)



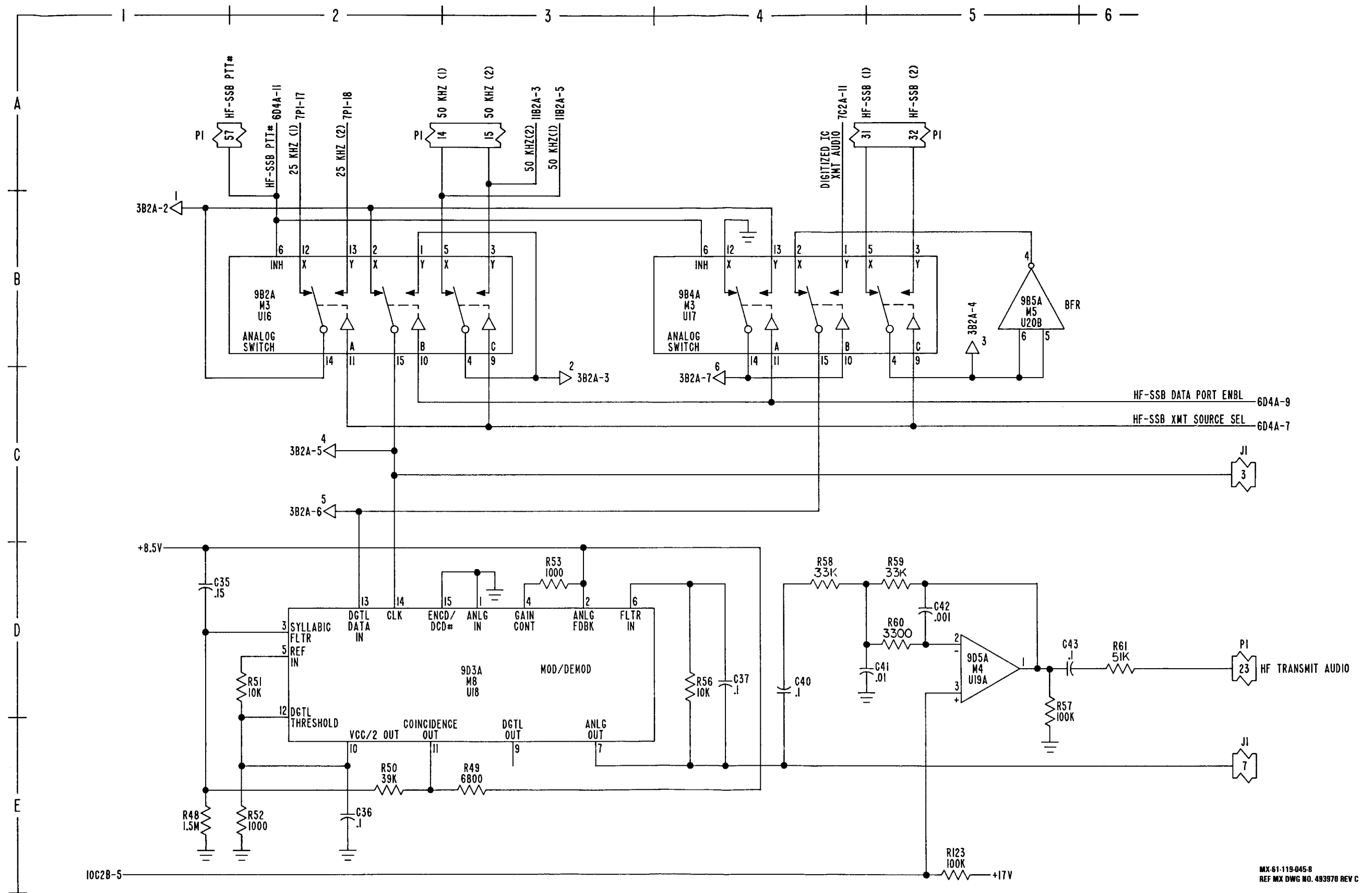

MX-61-119-045-8  
REF MX DWG NO. 483970 REV C

FO-3. SDU Audio Interface (2) Schematic Diagram (Sheet 8 of 11)

FO-35/(FO-36 blank)



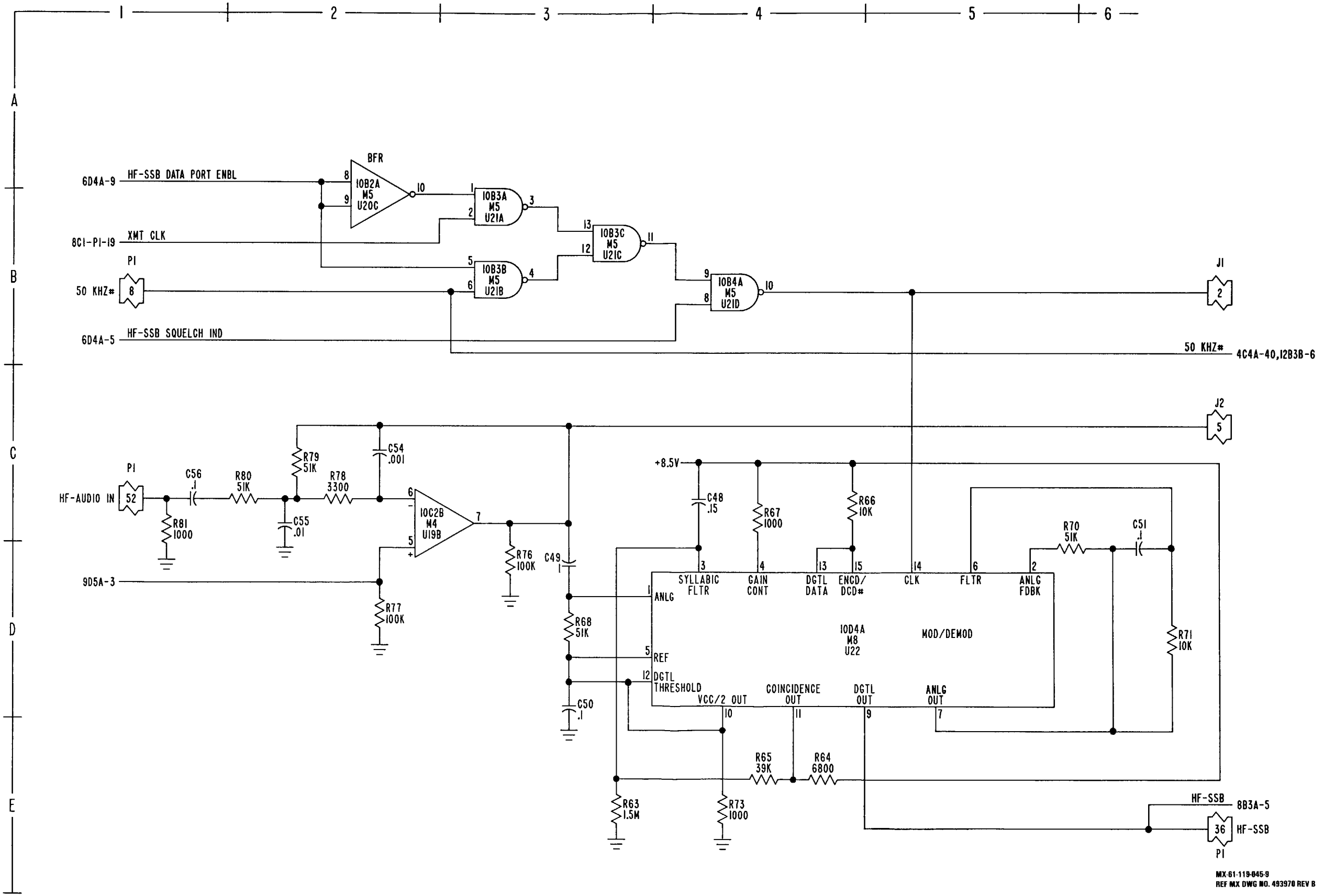

FO-3. SDU Audio Interface (2) Schematic Diagram (Sheet 9 of 11)



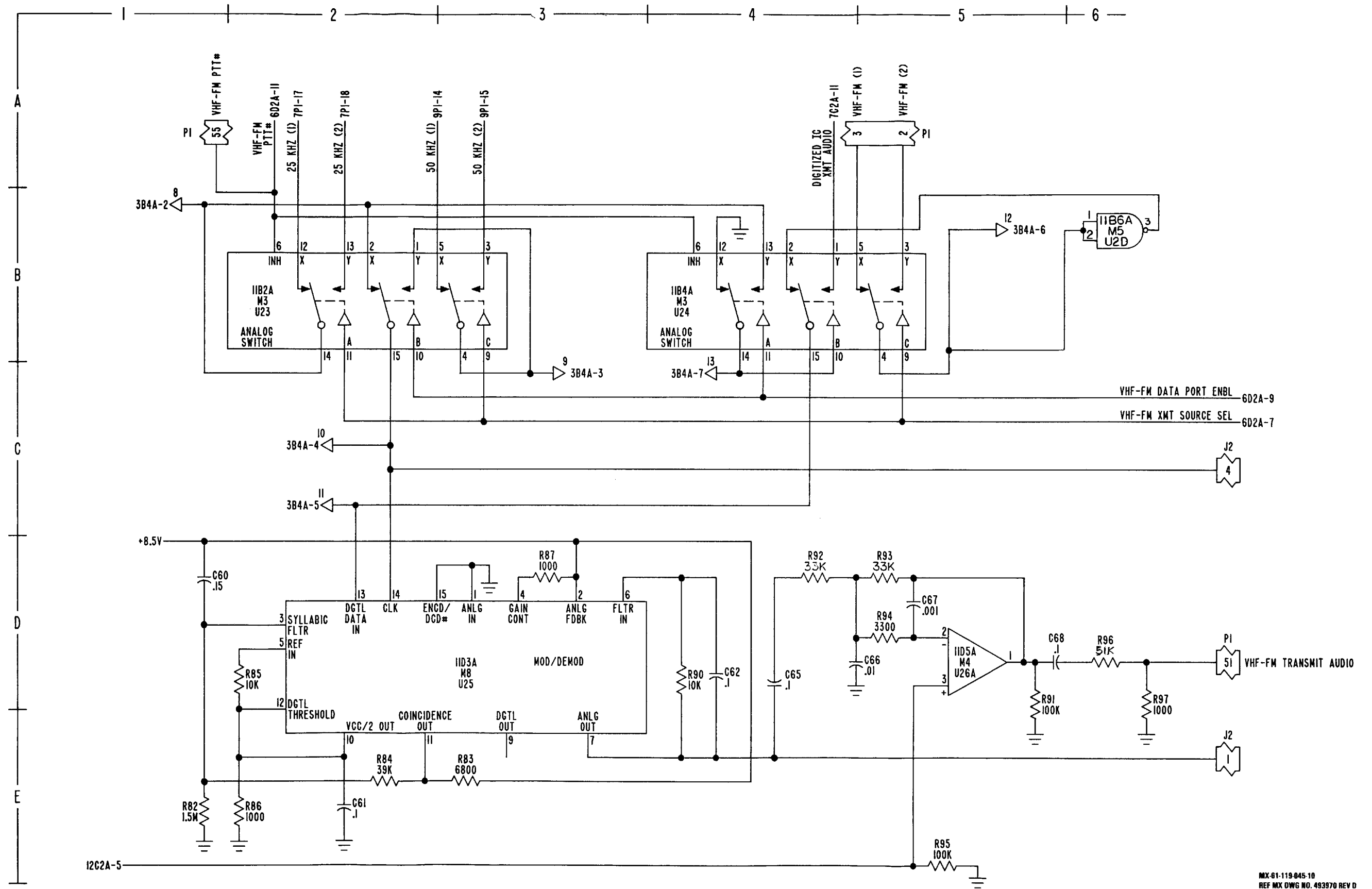

MX-61-119-045-10  
REF MX DWG NO. 493970 REV D

FO-3. SDU Audio Interface (2) Schematic Diagram (Sheet 10 of 11)

FO-39/(FO-40 blank)





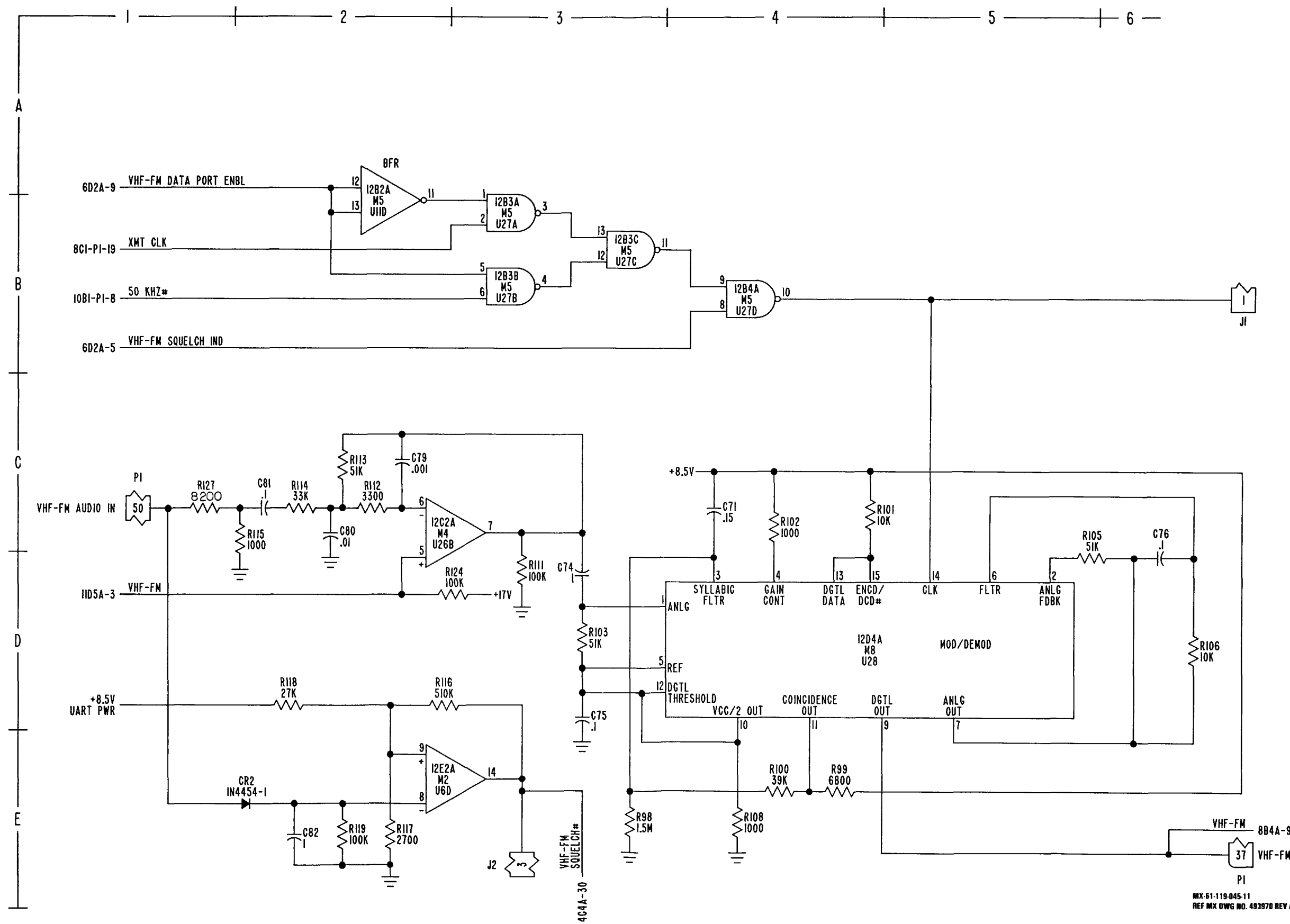

MX-61-119-045-11  
REF MX DWG NO. 493970 REV A

FO-3. SDU Audio Interface (2) Schematic Diagram (Sheet 11 of 11)

FO-41/(FO-42 blank)



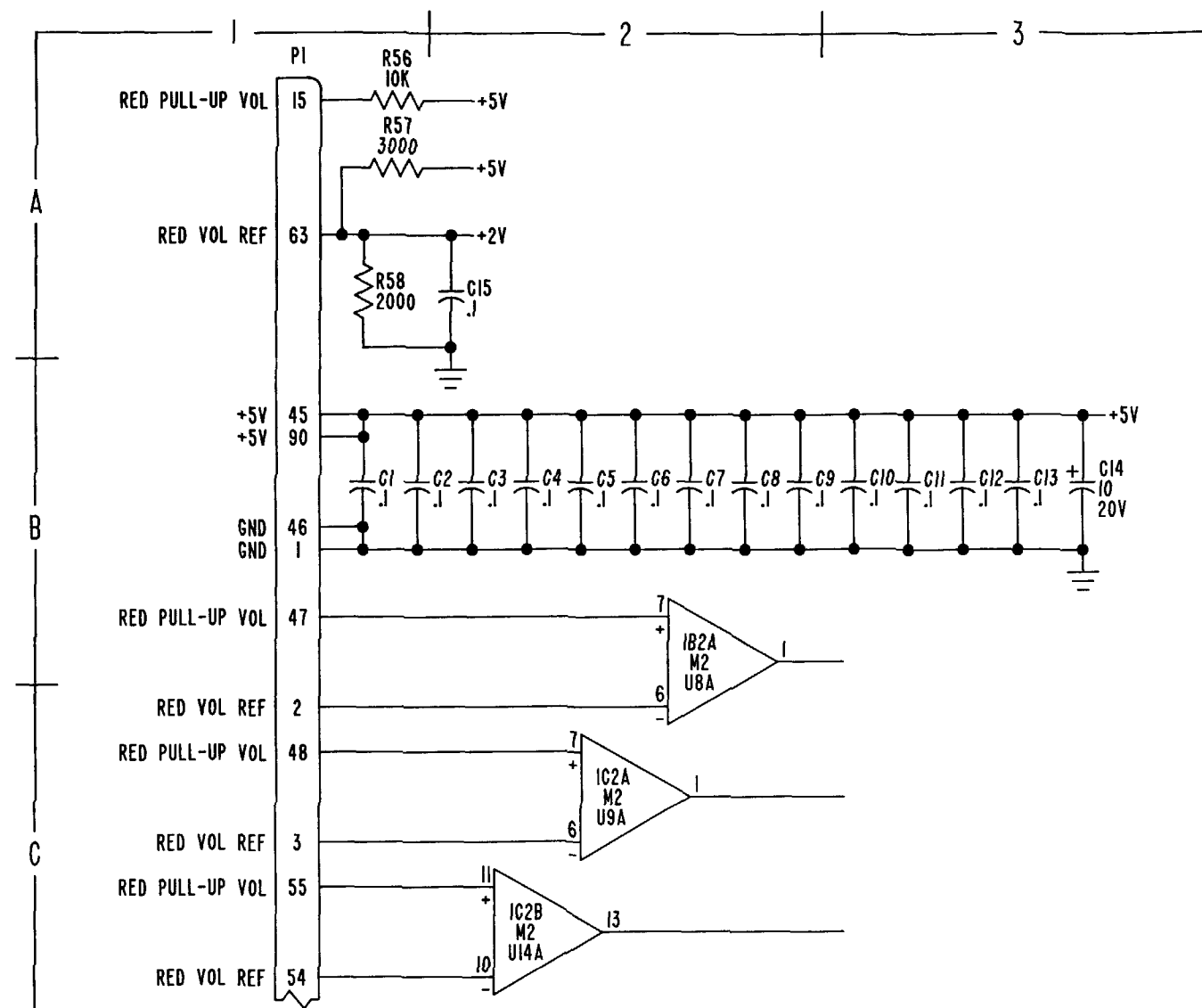

NOTES:

- 1.0 GENERAL:
  - 1.1 INTERPRET DRAWING IN ACCORDANCE WITH STANDARDS PRESCRIBED BY DOD-STD-100.
  - 1.2 DATA INCLUDED IN PARENTHESIS, ( ), IS FOR REFERENCE ONLY.
  - 1.3 A NUMBER SIGN (#) FOLLOWING A SIGNAL NAME MEANS THE INVERTED (NOT) FORM OF THE SIGNAL.
- 2.0 SPECIFIC:
  - 2.1 UNLESS OTHERWISE SPECIFIED: RESISTANCE VALUES ARE IN OHMS. RESISTORS ARE 5%, 1/4W. CAPACITANCE VALUES ARE IN MICROFARADS. VOLTAGES ARE DC. DIODES AND/OR TRANSISTORS ARE JANTX TYPE.
  - 2.2 PARTIAL REFERENCE DESIGNATIONS ARE SHOWN: FOR COMPLETE DESIGNATION PREFIX WITH UNIT NUMBER AND SUBASSEMBLY DESIGNATION IA3.
  - 2.3 FOR CONTINUATION OF CIRCUIT SEE 493946.
  - 2.4 THIS DEVICE REQUIRES SPECIAL HANDLING AND PROCESSING TO PREVENT DAMAGE FROM ELECTROSTATIC DISCHARGE TRANSIENTS.
  - 2.5 REFERENCE: ASSEMBLY NUMBER 812154-801. PRINTED WIRING BOARD 412044-1.

| INTEGRATED CIRCUIT TABLE |                         |                  |                  |     |
|--------------------------|-------------------------|------------------|------------------|-----|
| REF DESIGNATION          | SECOND TAGGING LINE SYM | PART NUMBER      | POWER INPUT PINS |     |
|                          |                         |                  | +5V              | GND |
| U13                      | M1                      | JM38510/30701BEX | 16               | 8   |
| U6, 7, 8, 9, 14          | M2                      | JM38510/11201BCX | 3                | 12  |
| U4, 5                    | M3                      | 615886-901       | 20               | 10  |
| U10, 11, 12              | M4                      | 646197-901       | 26               | 4   |
| U1                       | M5                      | 616489-902       | 26               | 7   |
| U2,3                     | M6                      | 616529-904       | NA               | 8   |
| R1, 2, 59                | M7                      | M8340102M1002GB  | 16               | NA  |

| REF DESIGNATION                        |            |
|--|------------|
| HIGHEST USED                           | NOT USED   |
| C15<br>CR14<br>P1<br>R63<br>TP4<br>U14 | R39<br>R44 |

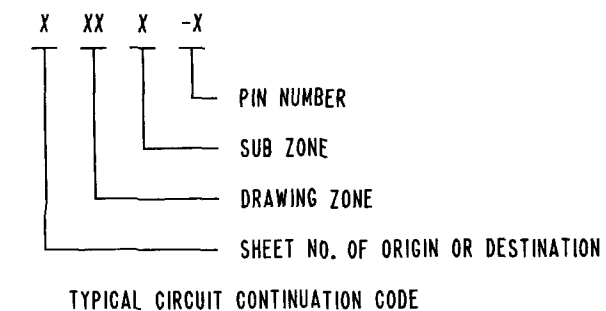

2.4  
2.4



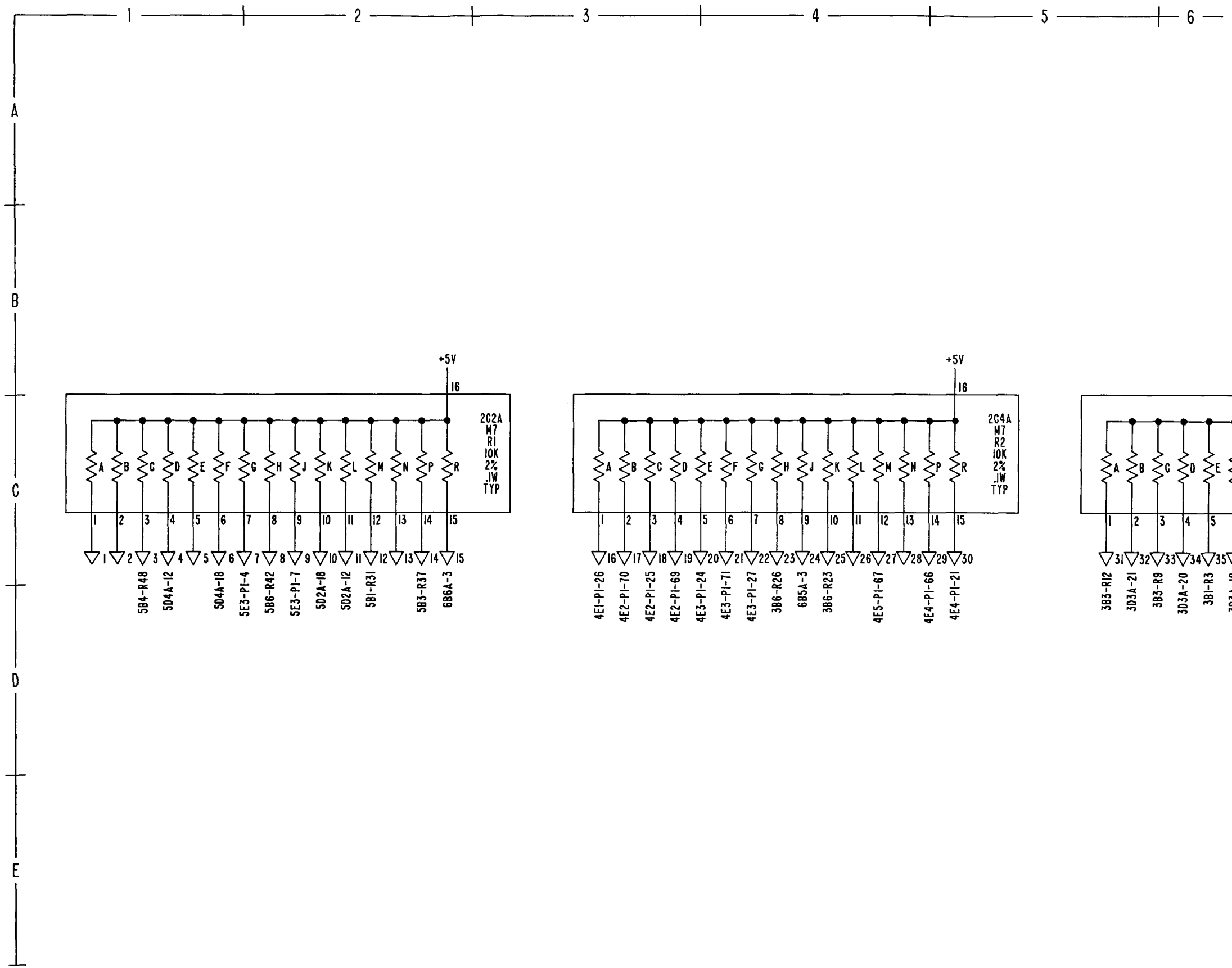

MX 61-119-846-2  
REF MX DWG NO. 493975 REV D

FO-4. SDU Red Interface Schematic Diagram (Sheet 2 of 6)

FO-45/(FO-46 blank)



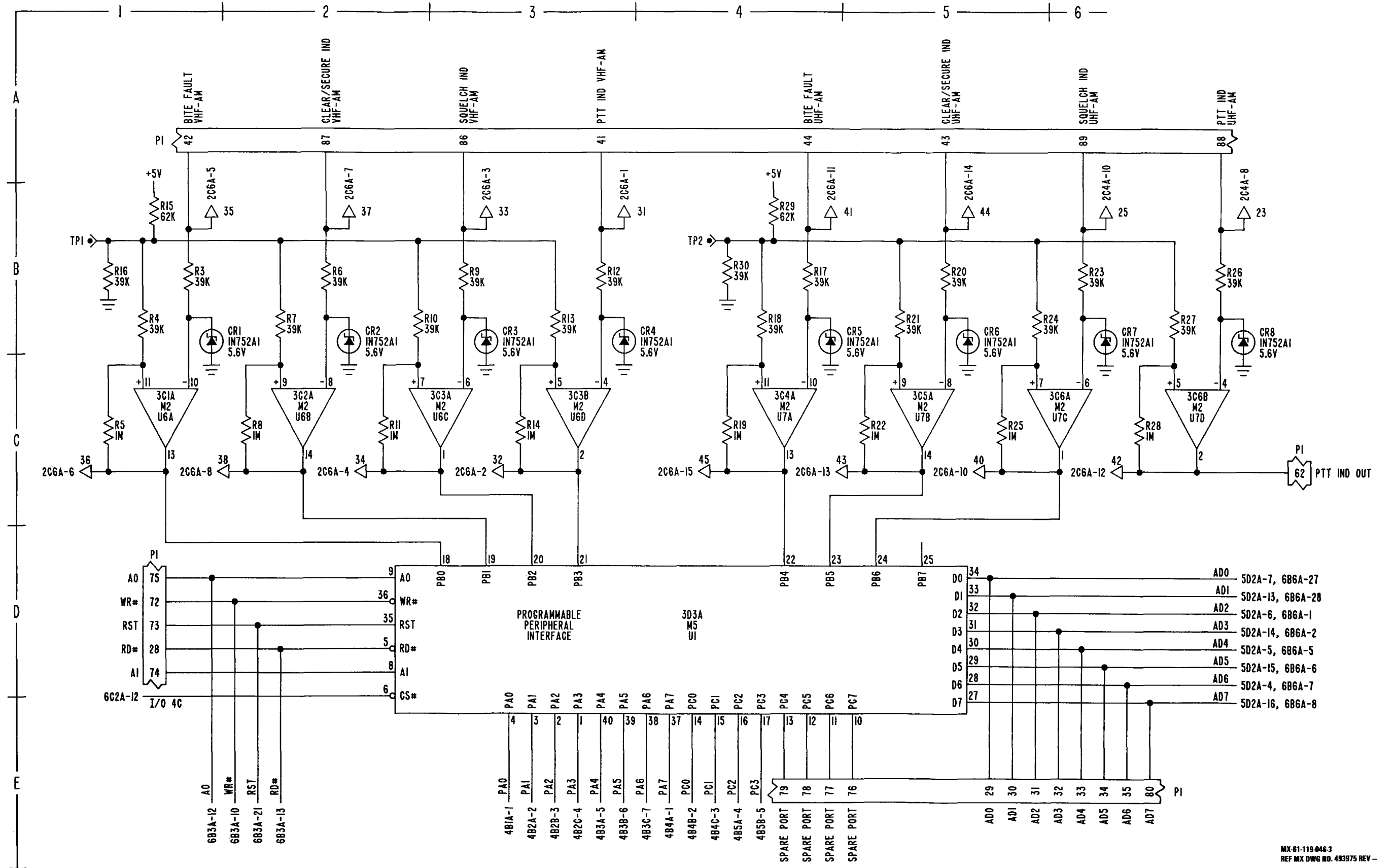

FO-4. SDU Red Interface Schematic Diagram (Sheet 3 of 6)





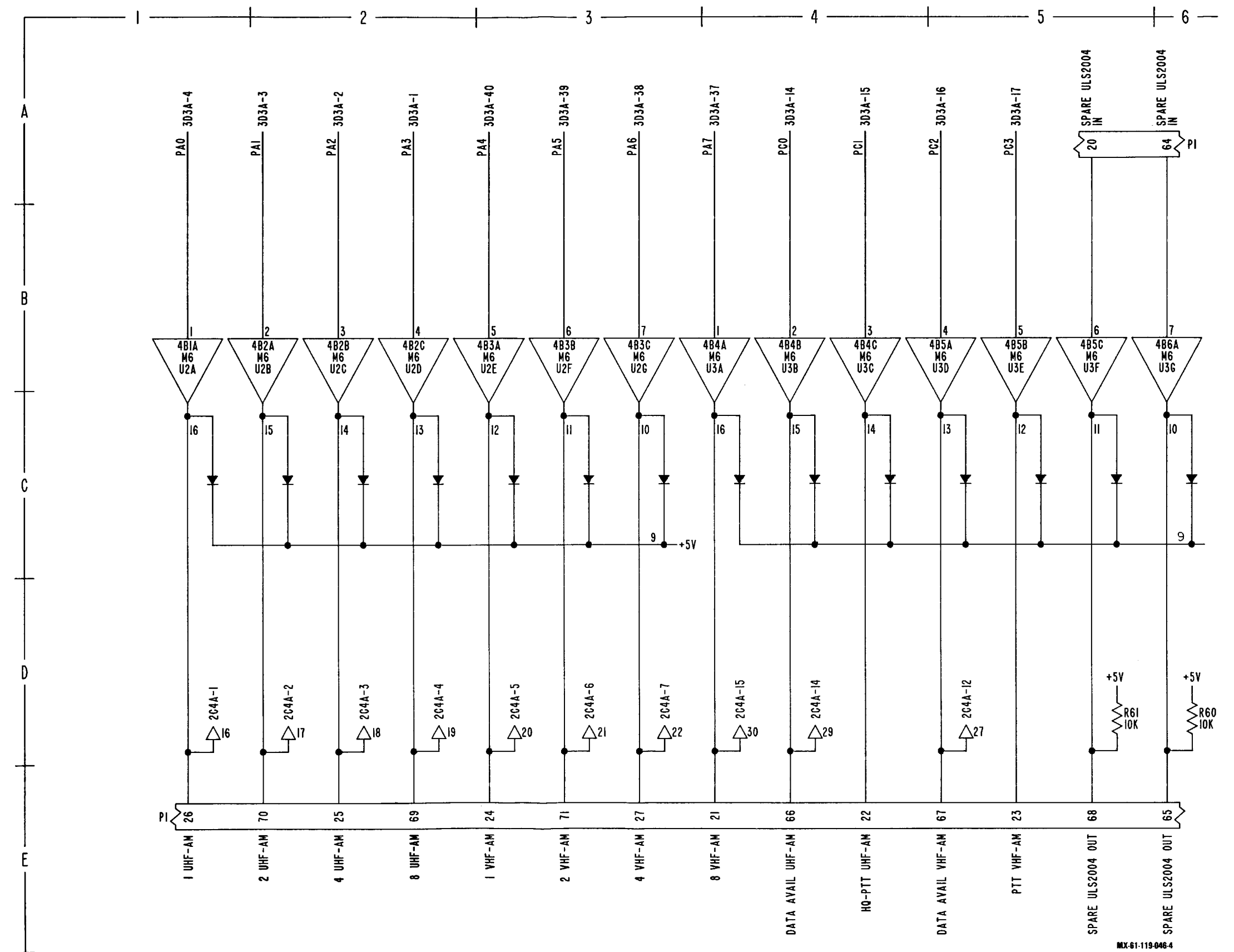

MX-61-119-046-4  
REF MX DWG NO. 493975 REV E

FO-4. SDU Red Interface Schematic Diagram (Sheet 4 of 6)



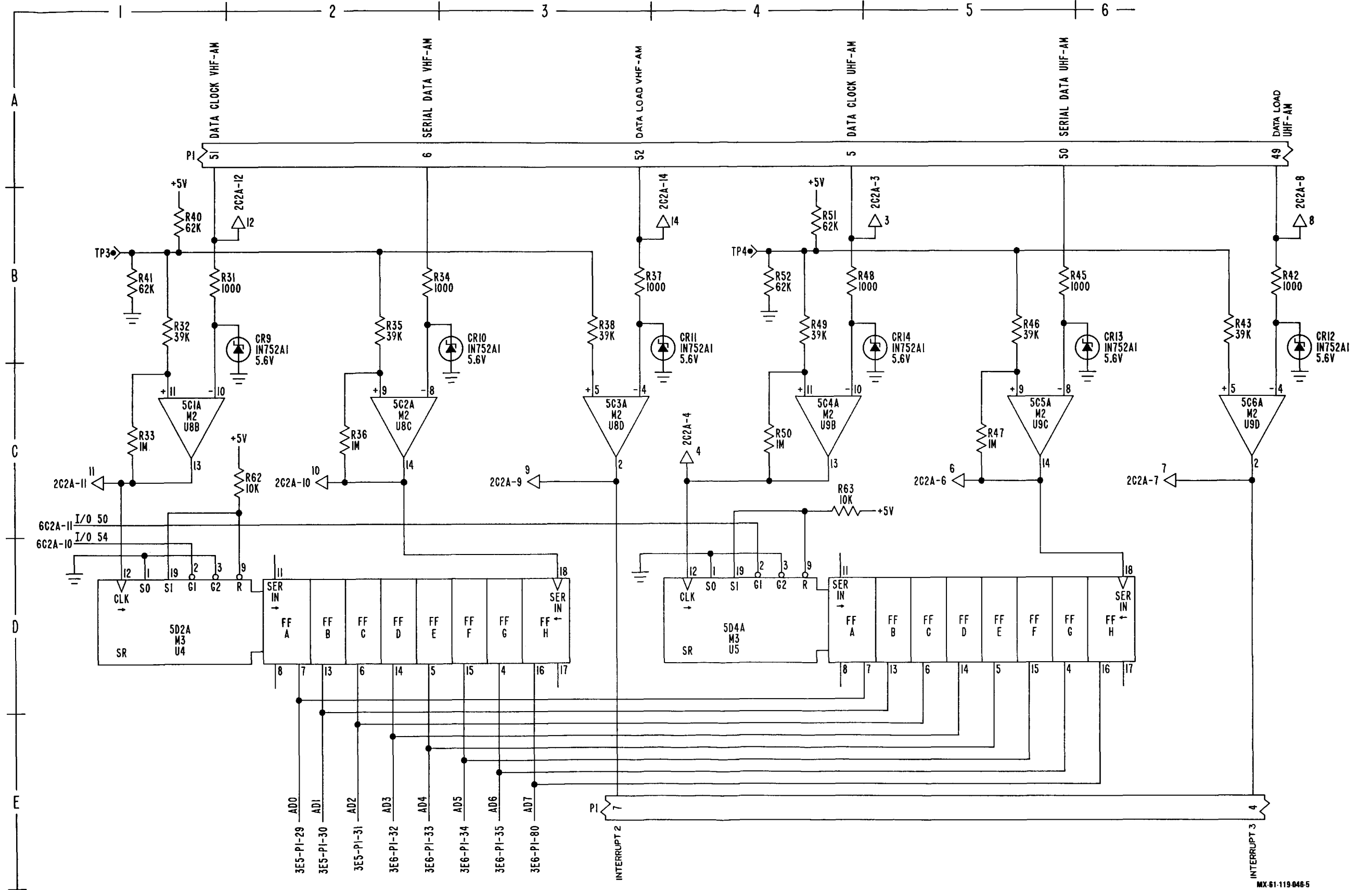

MX 61-119-046-5  
 REF MX DWG NO. 493975 REV D  
 FO-4. SDU Red Interface Schematic  
 Diagram (Sheet 5 of 6)



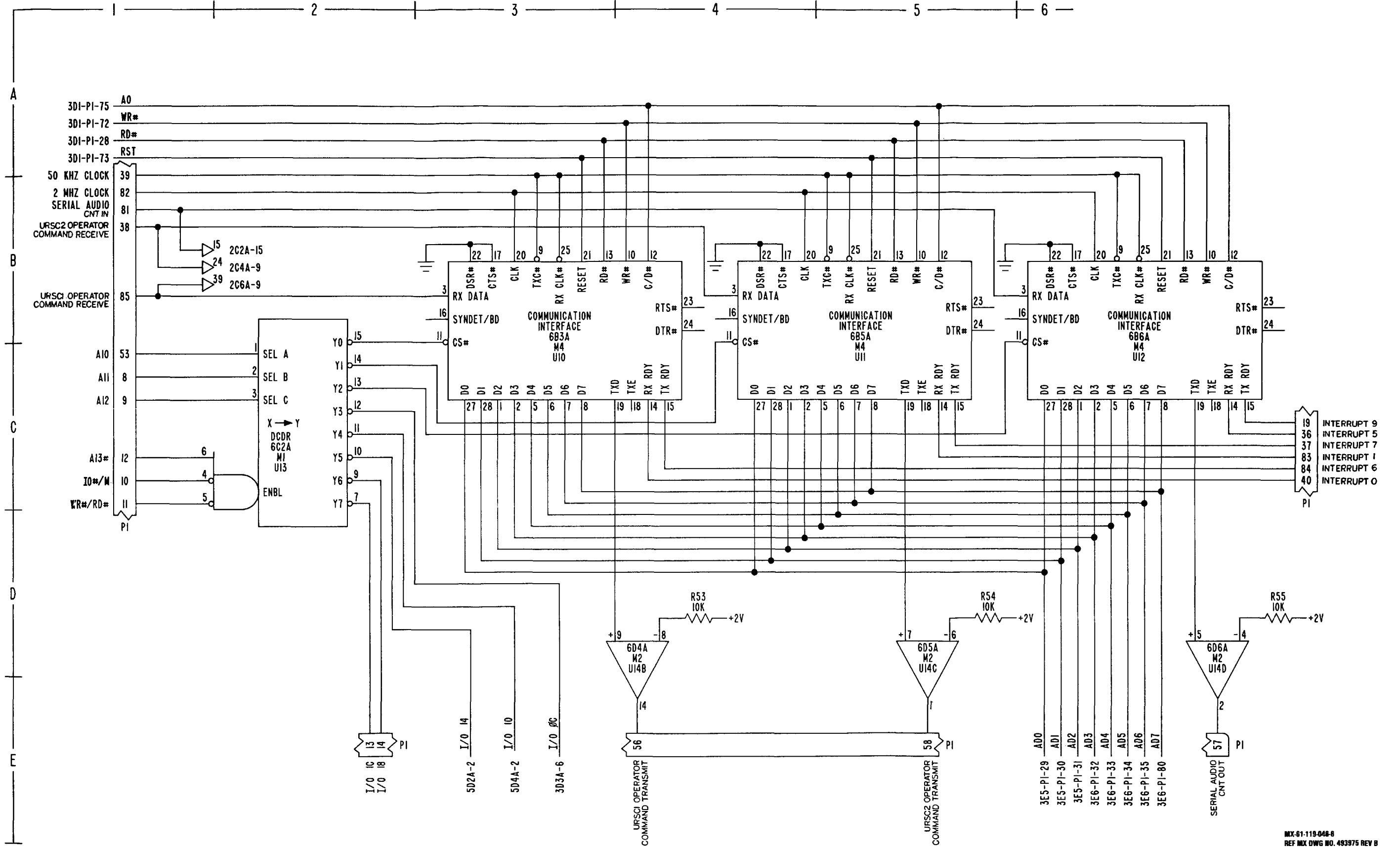

FO-4. SDU Red Interface Schematic Diagram (Sheet 6 of 6)

MX-61-119-048-8  
REF MX DWG NO. 493975 REV B



| REF DESIGNATION                               |                              |
|---|------------------------------|
| HIGHEST USED                                  | NOT USED                     |
| C15<br>CR3B<br>P1<br>Q10<br>R48<br>TP2<br>U14 | C4<br><br><br><br><br><br>U4 |

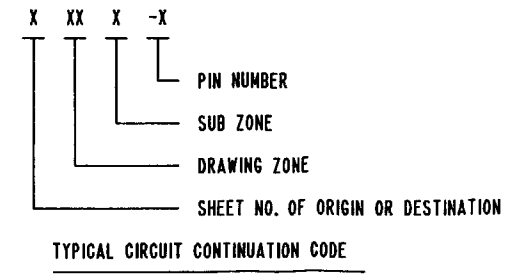

- NOTES:
- 1.0 GENERAL:
    - 1.1 INTERPRET DRAWING IN ACCORDANCE WITH STANDARDS PRESCRIBED BY DOD-STD-100.
    - 1.2 DATA INCLUDED IN PARENTHESIS, ( ), IS FOR REFERENCE ONLY.
    - 1.3 A NUMBER SIGN (#) FOLLOWING A SIGNAL NAME MEANS THE INVERTED (NOT) FORM OF THE SIGNAL.
  - 2.0 SPECIFIC:
    - 2.1 UNLESS OTHERWISE SPECIFIED: RESISTANCE VALUES ARE IN OHMS. RESISTORS ARE 5%, 1/4W. CAPACITANCE VALUES ARE IN MICROFARADS. VOLTAGES ARE DC. DIODES AND/OR TRANSISTORS ARE JANTX TYPE.
    - 2.2 PARTIAL REFERENCE DESIGNATIONS ARE SHOWN: FOR COMPLETE DESIGNATION PREFIX WITH UNIT NUMBER AND SUBASSEMBLY DESIGNATION 1A4.
    - 2.3 FOR CONTINUATION OF CIRCUIT SEE 493946.
    - 2.4 THIS DEVICE REQUIRES SPECIAL HANDLING AND PROCESSING TO PREVENT DAMAGE FROM ELECTROSTATIC DISCHARGE TRANSIENTS.
    - 2.5 REFERENCE: ASSEMBLY NUMBER 812117-801. PRINTED WIRING BOARD 412042-1.

| INTEGRATED CIRCUIT TABLE |                         |                  |                  |      |      |     |
|--------------------------|-------------------------|------------------|------------------|------|------|-----|
| REFERENCE DESIGNATION    | SECOND TAGGING LINE SYM | PART NUMBER      | POWER INPUT PINS |      |      |     |
|                          |                         |                  | +5V              | +28V | -28V | GND |
| U7,8,12                  | M1                      | JM3851Q/1120IBCX | 3                | NA   | NA   | 12  |
| 2.4 U1                   | M2                      | 615660-903       | 6                | NA   | 14   | 19  |
| 2.4 U13                  | M3                      | 615766-902       | 16               | NA   | NA   | 8   |
| U14                      | M4                      | JM3851Q/32803BRX | 20               | NA   | NA   | 10  |
| U9                       | M5                      | JM3851Q/3200IBCX | 14               | NA   | NA   | 7   |
| 2.4 U11                  | M6                      | 616488-902       | 26               | NA   | NA   | 4   |
| 2.4 U2,3                 | M7                      | 616489-902       | 26               | NA   | NA   | 7   |
| U5,6                     | M8                      | 616529-904       | NA               | 9    | NA   | 8   |
| U10                      | M9                      | JM3851Q/32002BCX | 14               | NA   | NA   | 7   |
| R39,40                   | M10                     | M8340102M1002GB  | 16               | NA   | NA   | NA  |
| R41                      |                         |                  | NA               | 16   | NA   | NA  |

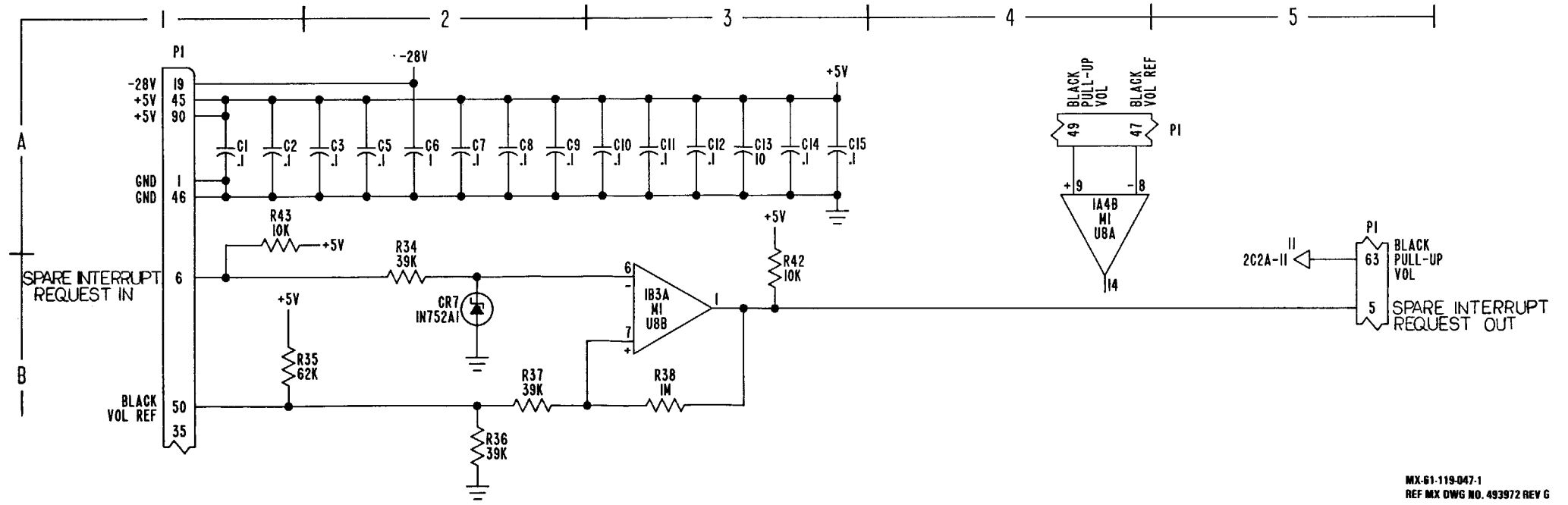

MX-61-119-047-1  
REF MX DWG NO. 493972 REV G

FO-5. SDU Black Interface Schematic Diagram (Sheet 1 of 6)





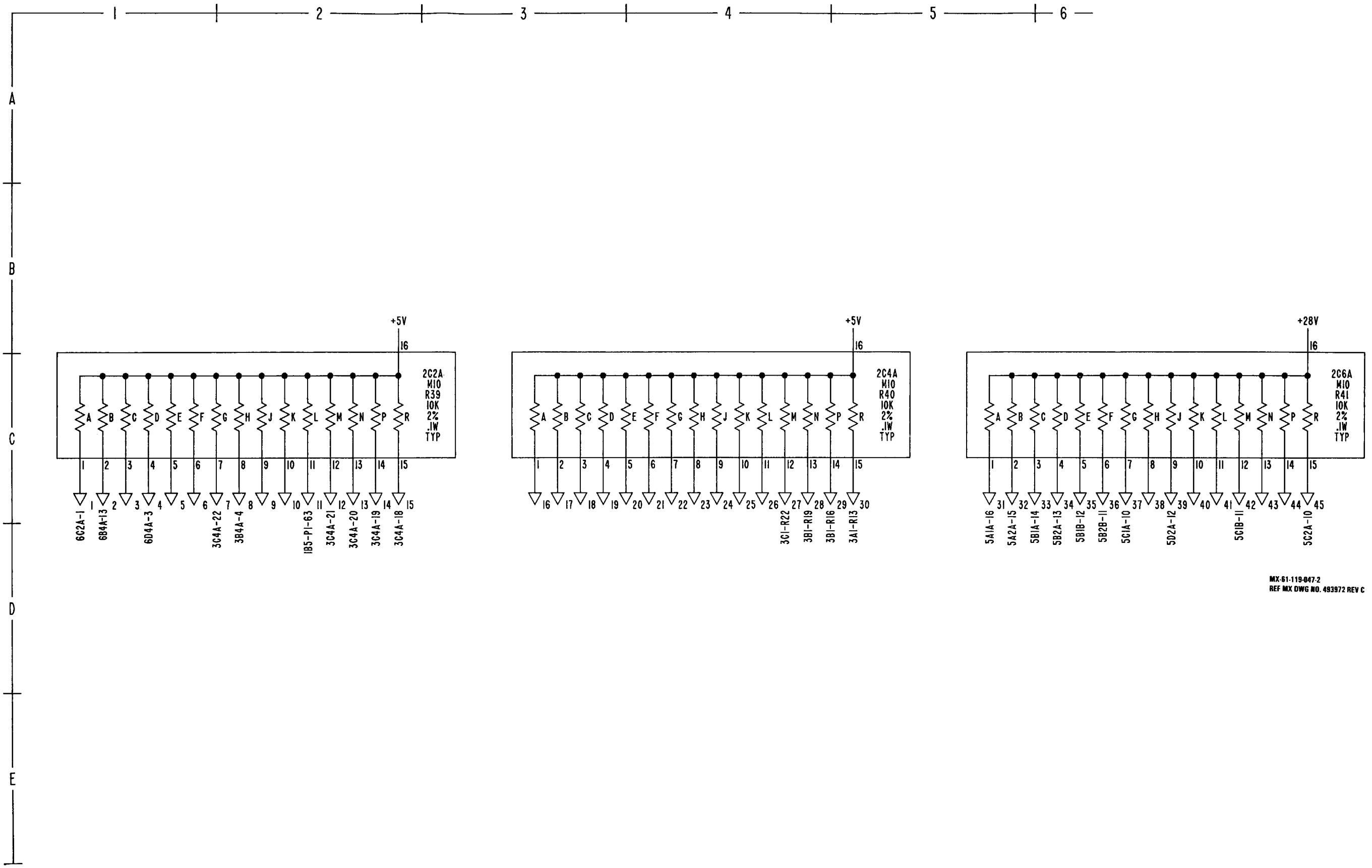

MX-61-119-047-2  
REF MX DWG NO. 493972 REV C



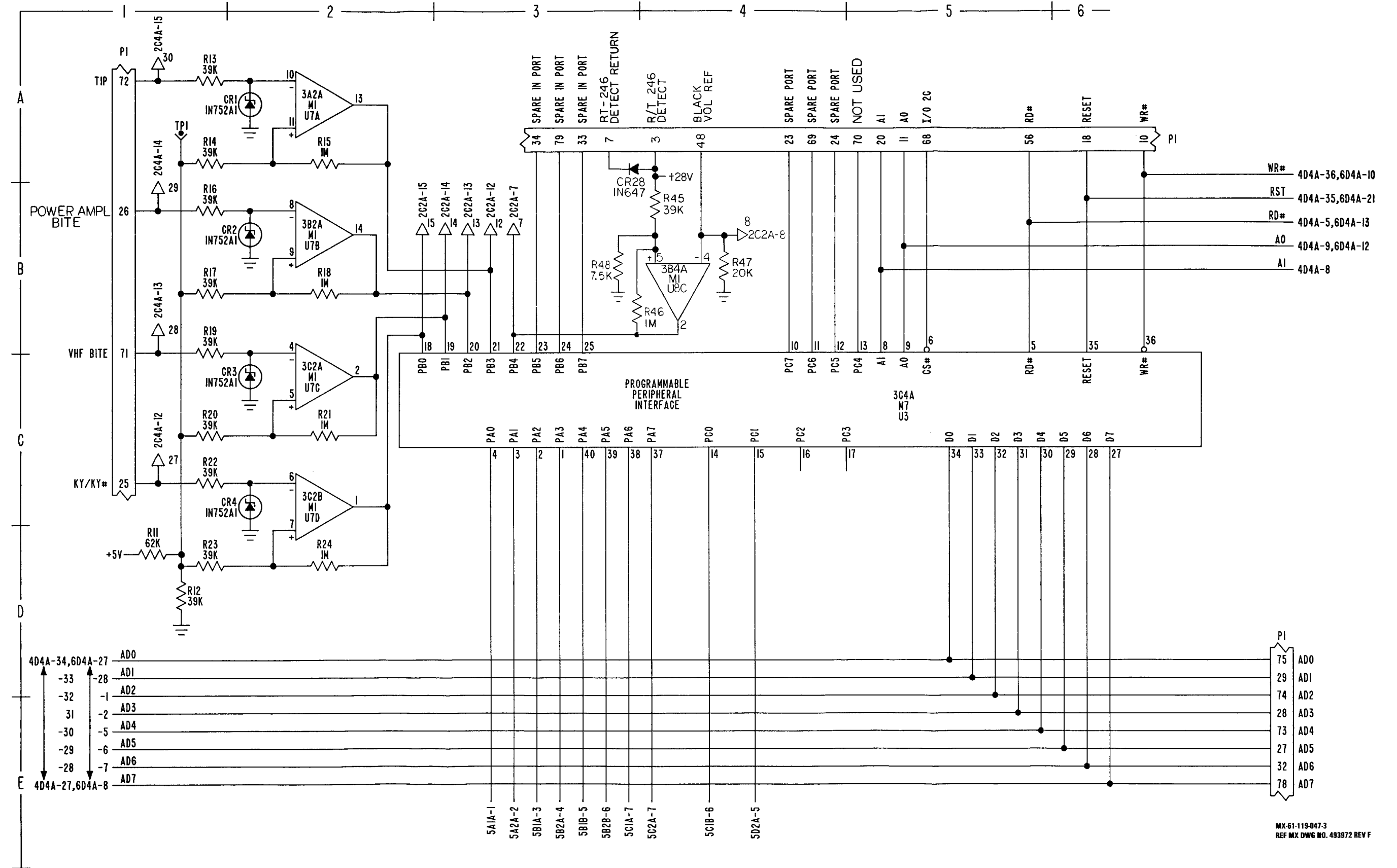

MX-61-119-047-3  
REF MX DWG NO. 493972 REV F

F0-5. SDU Black Interface Schematic Diagram (Sheet 3 of 6)

F0-59/(F0-60 blank)



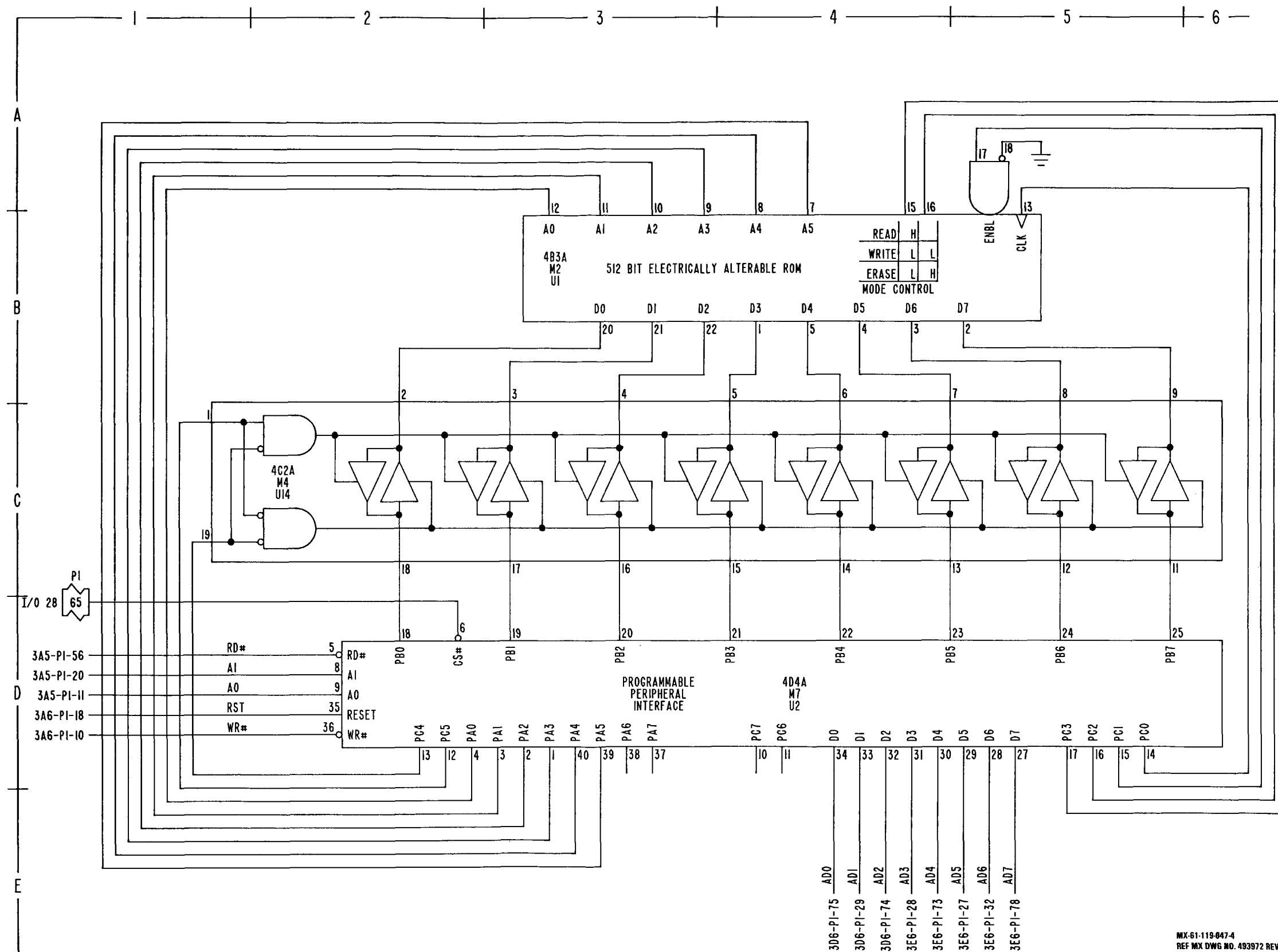

MX-61-119-847-4  
REF MX DWG NO. 493972 REV -

FO-5. SDU Black Interface Schematic Diagram (Sheet 4 of 6)



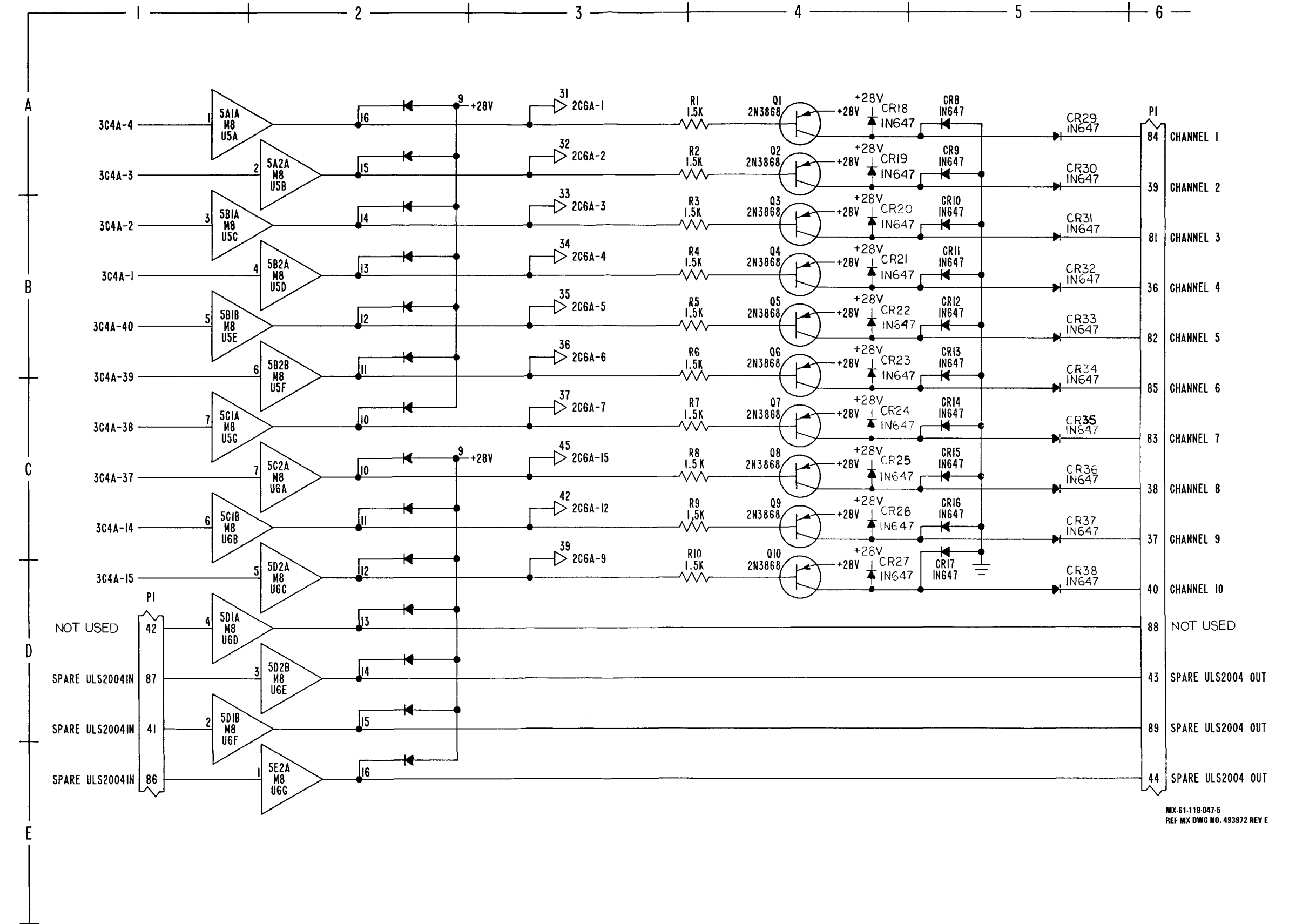

MX-61-119-047-5  
REF MX DWG NO. 493972 REV E

FO-5. SDU Black Interface Schematic Diagram (Sheet 5 of 6)

FO-63/(FO-64 blank)





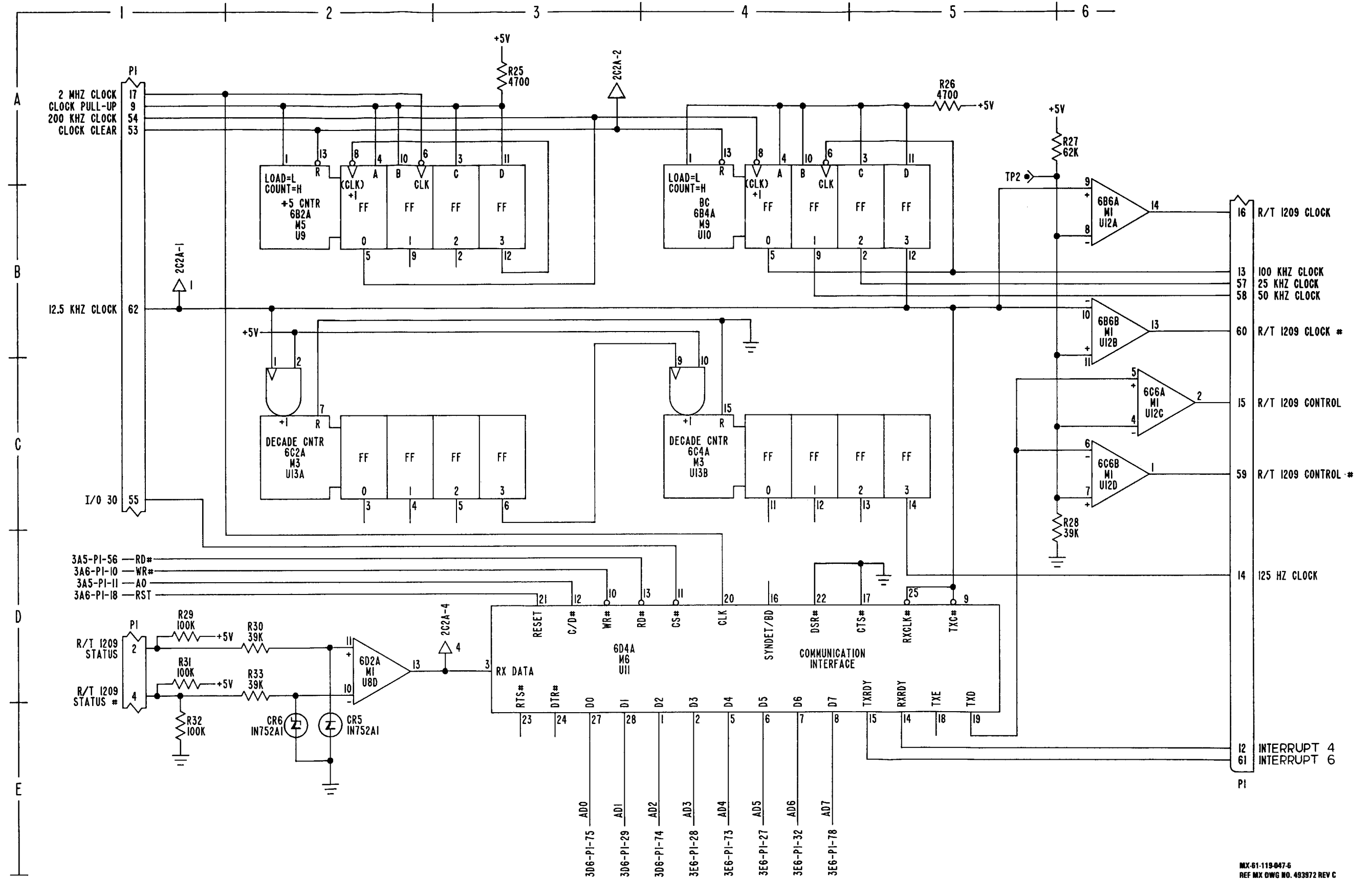

MX-61-115-047-5  
REF MX DWG NO. 493972 REV C

FO-5. SDU Black Interface Schematic Diagram (Sheet 6 of 6)



| REF DESIGNATION                |  |
|--------------------------------|--|
| HIGHEST USED                   | NOT USED                                       |
| C32<br>CR2<br>PI<br>R15<br>U25 | C4, 6, 7, 15,<br>18 THRU 21,<br>24 & 25<br>R10 |

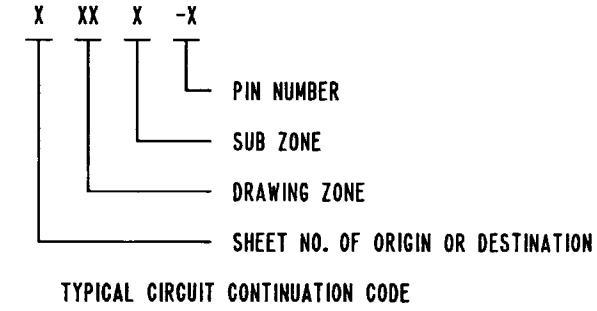

| INTEGRATED CIRCUIT TABLE      |                         |                   |                  |     |
|-------------------------------|-------------------------|-------------------|------------------|-----|
| REFERENCE DESIGNATION         | SECOND TAGGING LINE SYM | PART NUMBER       | POWER INPUT PINS |     |
|                               |                         |                   | +5V              | GND |
| U8,9,13                       | M1                      | JM38510/30701 BEX | 16               | 8   |
| U22,23                        | M2                      | JM38510/30003BCX  | 14               | 7   |
| U24                           | M3                      | JM38510/30001BCX  | 14               | 7   |
| U12                           | M4                      | JM38510/11201 BCX | 3                | 12  |
| U7                            | M5                      | JM38510/32403BRX  | 20               | 10  |
| U6                            | M6                      | JM38510/32502BRX  | 20               | 10  |
| 2.4 U14,15,16,17,18,19,20,21, | M7                      | JM38510/23602BVX  | 18               | 9   |
| 2.4 U5                        | M8                      | 7901001 QX        | 40               | 20  |
| 2.4 U10,11                    | M9                      | 616486-904        | 28               | 14  |
| U1                            | M10                     | 646316-901        | 24               | 12  |
| U25                           | M11                     | 626724-1          | NA               | NA  |
| R1,2,3,4                      | M12                     | M8340102M1002GB   | 16               | NA  |
| U2                            | M13                     | 646317-901        | 24               | 12  |
| U3                            | M14                     | 646318-901        | 24               | 12  |
| U4                            | M15                     | 646319-901        | 24               | 12  |

NOTES:

- 1.0 GENERAL:
  - 1.1 INTERPRET DRAWING IN ACCORDANCE WITH STANDARDS PRESCRIBED BY DOD-STD-100.
  - 1.2 DATA INCLUDED IN PARENTHESIS, ( ), IS FOR REFERENCE ONLY.
  - 1.3 A NUMBER SIGN (#) FOLLOWING A SIGNAL NAME MEANS THE INVERTED (NOT) FORM OF THE SIGNAL.
- 2.0 SPECIFIC:
  - 2.1 UNLESS OTHERWISE SPECIFIED: RESISTANCE VALUES ARE IN OHMS. RESISTORS ARE 5%, 1/4 W. CAPACITANCE VALUES ARE IN MICROFARADS. VOLTAGES ARE DC. DIODES AND/OR TRANSISTORS ARE JANTX TYPE.
  - 2.2 PARTIAL REFERENCE DESIGNATIONS ARE SHOWN: FOR COMPLETE DESIGNATION PREFIX WITH UNIT NUMBER AND SUBASSEMBLY DESIGNATION IAS.
  - 2.3 FOR CONTINUATION OF CIRCUIT SEE SCHEMATIC 493946.
  - 2.4 THIS DEVICE REQUIRES SPECIAL HANDLING AND PROCESSING TO PREVENT DAMAGE FROM ELECTROSTATIC DISCHARGE TRANSIENTS.
  - 2.5 REFERENCE: ASSEMBLY NUMBER 812116-801. PRINTED WIRING BOARD 412041-1.

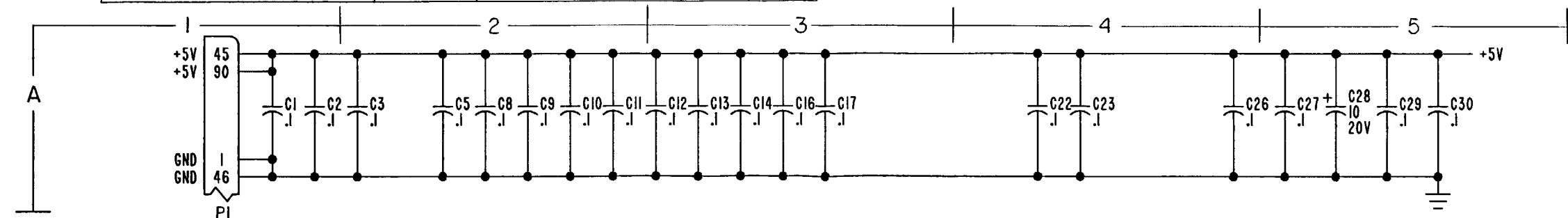

MX-61-119-048-1  
REF MX DWG NO. 493971 REV H

FO-6. CPU Schematic Diagram  
(Sheet 1 of 6)

FO-67/(FO-68 blank)



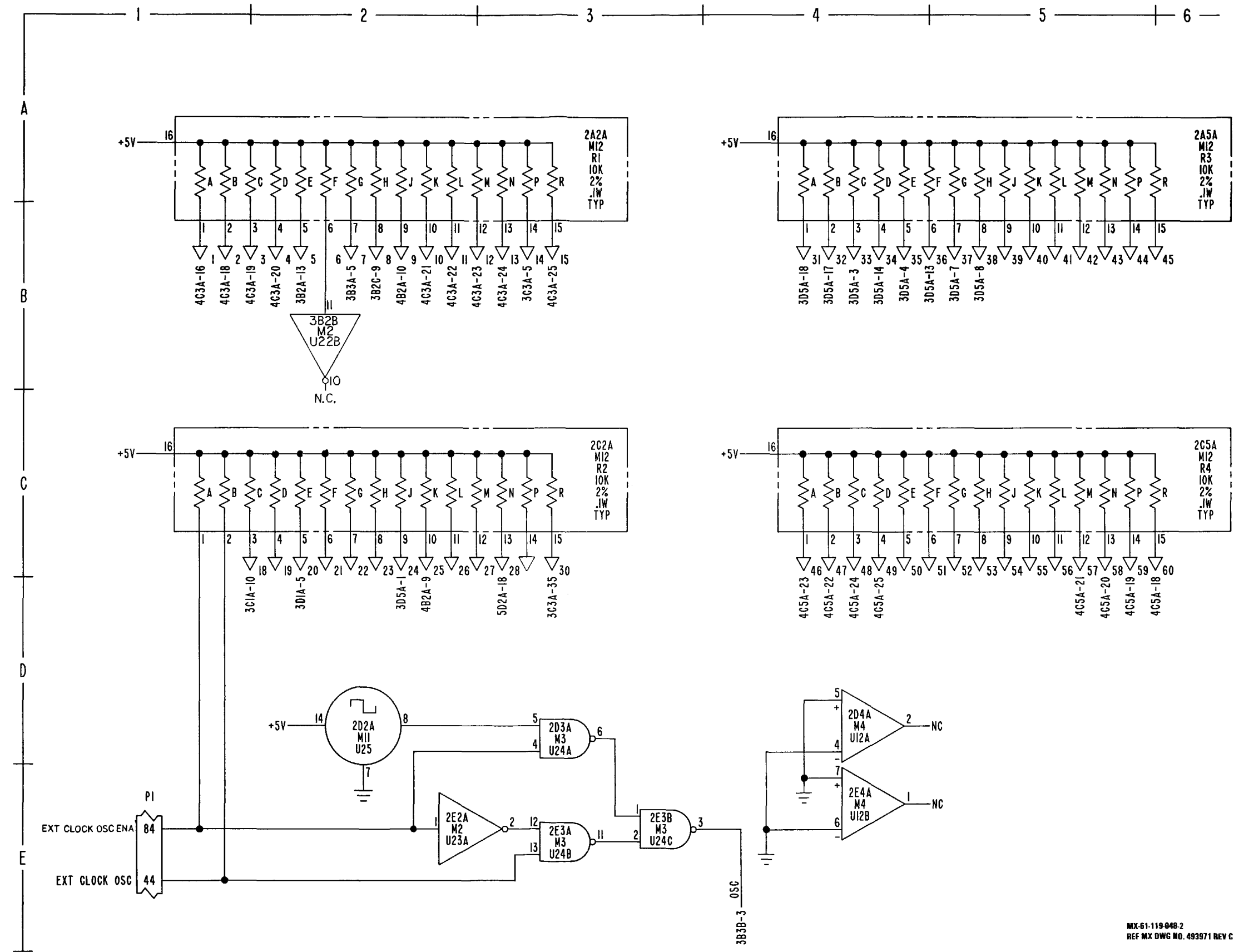

MX-61-119-048 2  
REF MX DWG NO. 493971 REV C

FO-6. CPU Schematic Diagram  
(Sheet 2 of 6)

FO-69/(FO-70 blank)



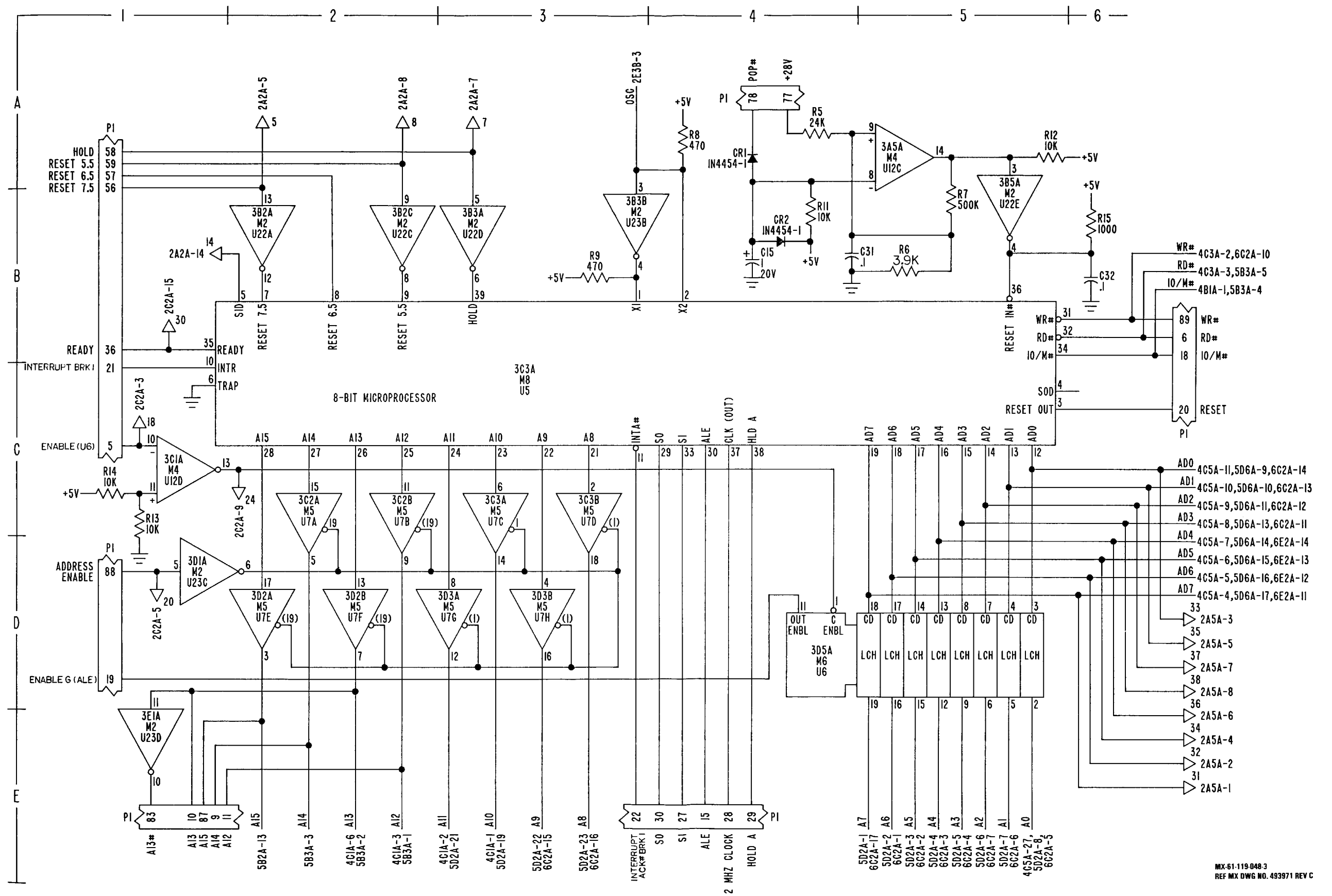

FO-6. CPU Schematic Diagram (Sheet 3 of 6)





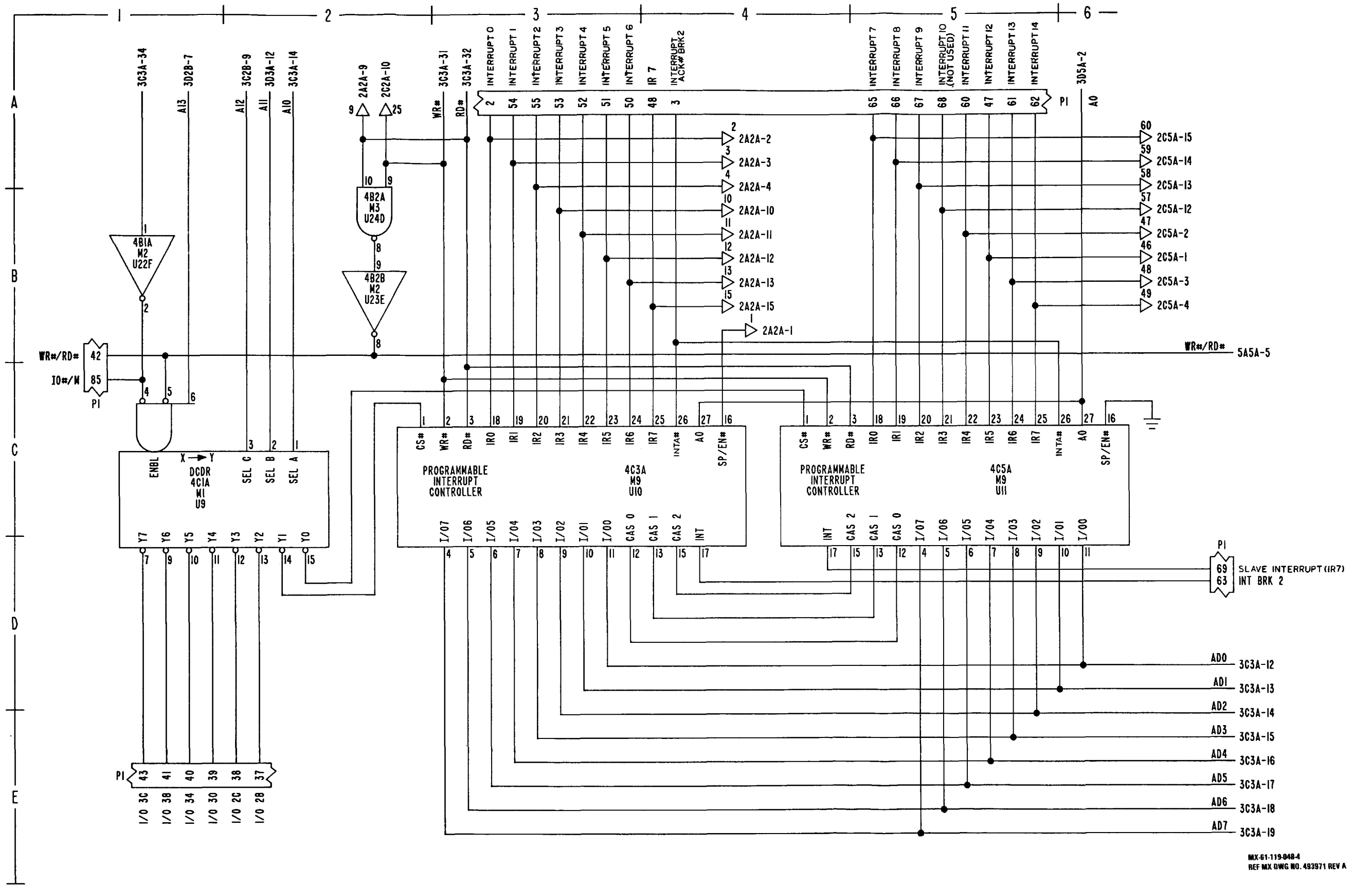

MX-61-119-048-4  
REF MX DWG NO. 483971 REV A

FO-6. CPU Schematic Diagram  
(Sheet 4 of 6)

FO-73/(FO-74 blank)



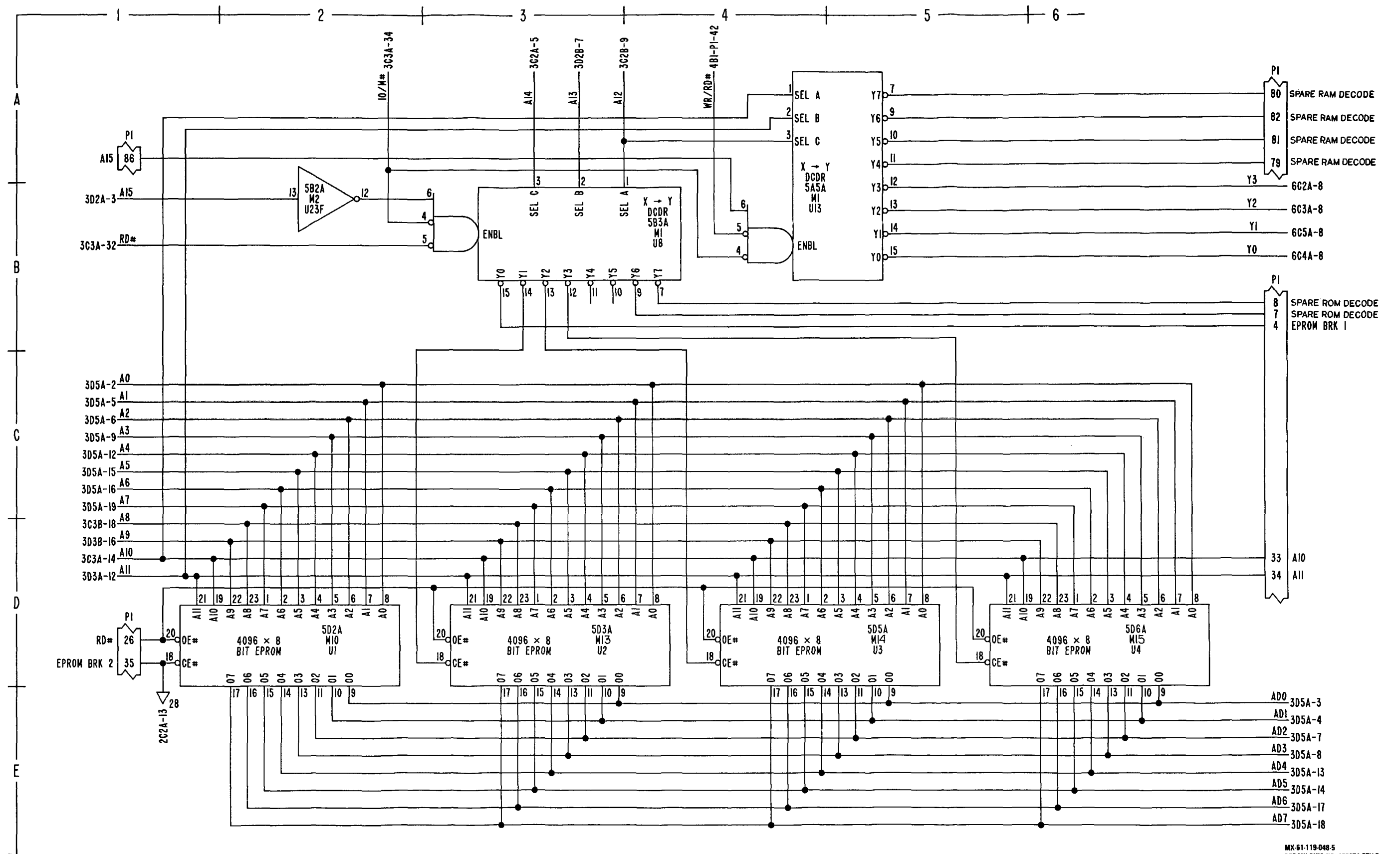

MX-61-119-048-5  
REF MX DWG NO. 483971 REV D

FO-6. CPU Schematic Diagram  
(Sheet 5 of 6)

FO-75/(FO-76 blank)



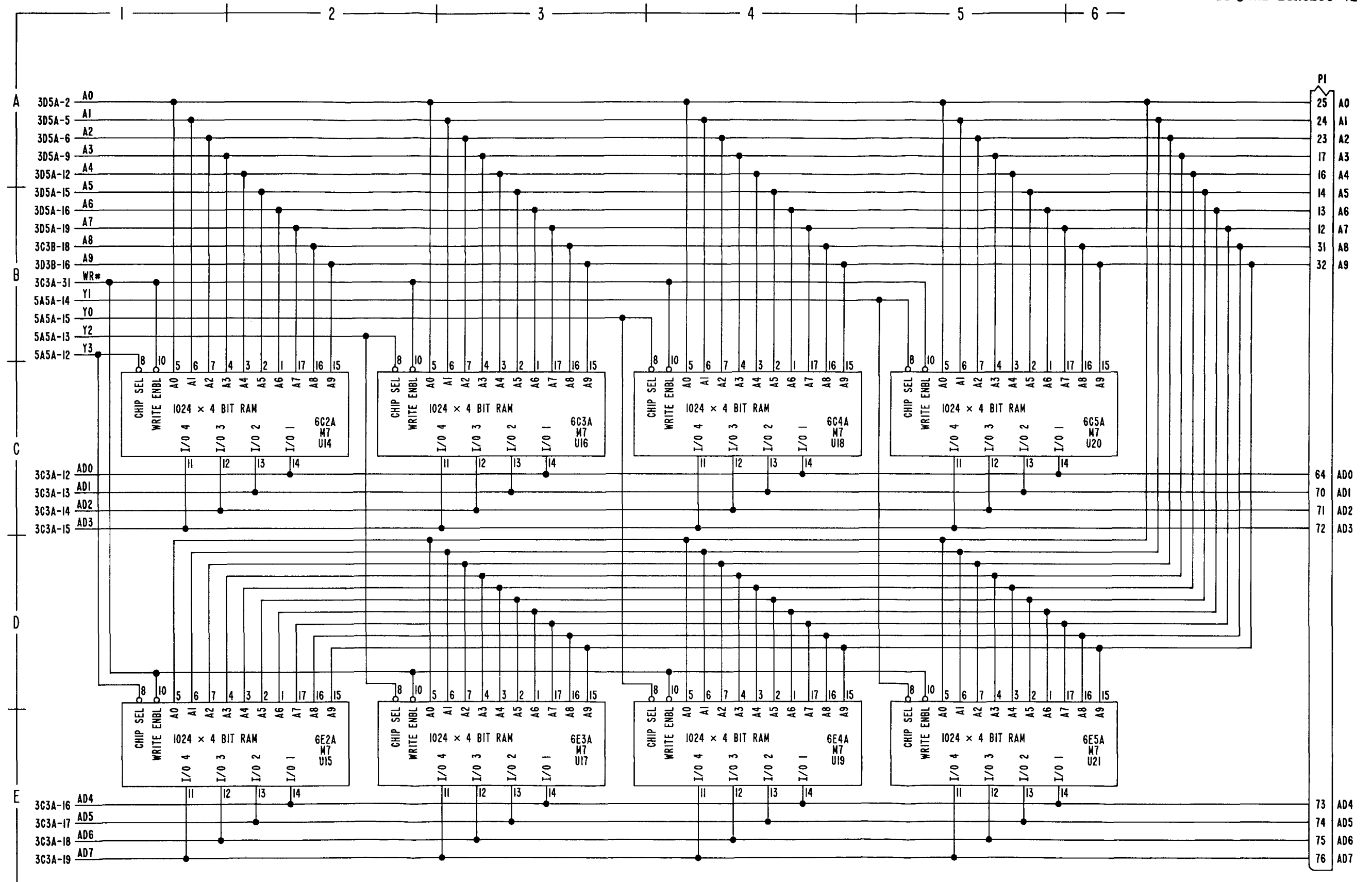

MX 61 119 048 6  
REF MX DWG NO. 493971 REV -

FO-6. CPU Schematic Diagram  
(Sheet 6 of 6)



NOTES:

- 1.0 GENERAL:
- 1.1 INTERPRET DRAWING IN ACCORDANCE WITH STANDARDS PRESCRIBED BY DOD-STD-100.
- 1.2 DATA INCLUDED IN PARENTHESIS, ( ), IS FOR REFERENCE ONLY.
- 2.0 SPECIFIC:
- 2.1 UNLESS OTHERWISE SPECIFIED: RESISTANCE VALUES ARE IN OHMS. RESISTORS ARE 5%, 1/4W. CAPACITANCE VALUES ARE IN MICROFARADS. VOLTAGES ARE DC. DIODES AND/OR TRANSISTORS ARE JANIX TYPE. 1/8W AND 2W RESISTORS ARE 1%.
- 2.2 PARTIAL REFERENCE DESIGNATIONS ARE SHOWN: FOR COMPLETE DESIGNATION PREFIX WITH UNIT NUMBER AND SUBASSEMBLY DESIGNATION IAG.
- 2.3 FOR CONTINUATION OF CIRCUIT SEE SCHEMATIC 493946.
- 2.4 VALUE SELECTED AT TEST, NOMINAL VALUE SHOWN.
- 2.5 PART NUMBER 646158-901.
- 2.6 REFERENCE: ASSEMBLY NUMBER 812122-801. PRINTED WIRING BOARD 412043-1.

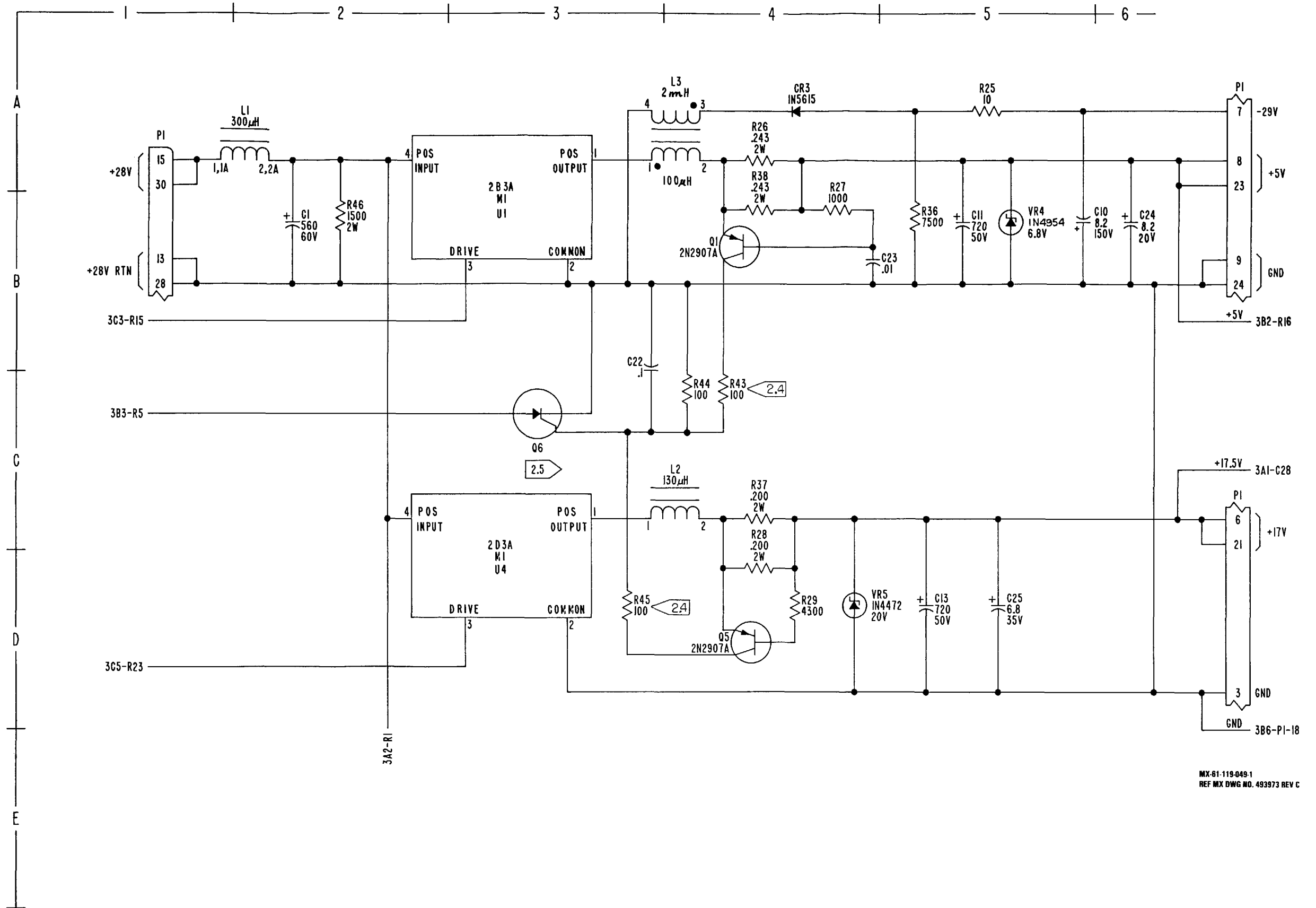
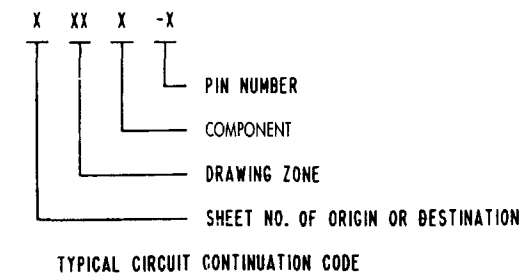

MX-61-119-049-1  
REF MX DWG NO. 493973 REV C





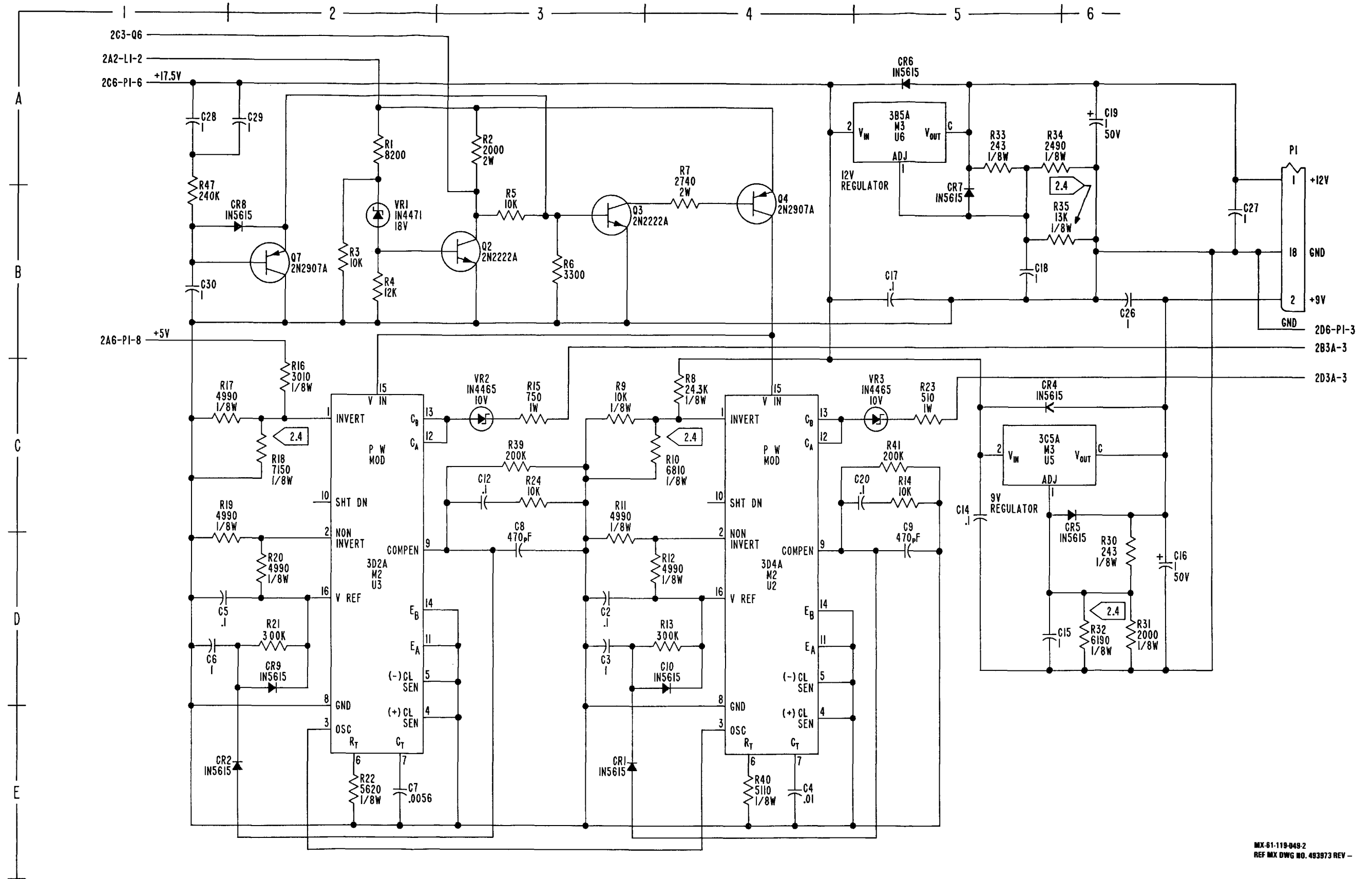

MX-61-119-048-2  
REF MX DWG NO. 483973 REV -

FO-7. SDU Power Supply Schematic Diagram (Sheet 2 of 2)



NOTES:

1.0 GENERAL:

- 1.1 INTERPRET DRAWING IN ACCORDANCE WITH STANDARDS PRESCRIBED BY DOD-STD-100.
- 1.2 DATA INCLUDED IN PARENTHESIS, ( ), IS FOR REFERENCE ONLY.

2.0 SPECIFIC:

- 2.1 UNLESS OTHERWISE SPECIFIED: RESISTANCE VALUES ARE IN OHMS. RESISTORS ARE 5% 1/8W. CAPACITANCE VALUES ARE IN MICROFARADS. VOLTAGES ARE DC. DIODES AND/OR TRANSISTORS ARE JANTX TYPE.
- 2.2 PARTIAL REFERENCE DESIGNATIONS ARE SHOWN: FOR COMPLETE DESIGNATION PREFIX WITH UNIT NUMBER AND SUBASSEMBLY DESIGNATION IAB & IA9.
- 2.3 FOR CONTINUATION OF CIRCUIT SEE SCHEMATIC 493946.

2.4 PART NUMBER 617713-902.

2.5 PART NUMBER 813821-801.

2.6 PART NUMBER 813820-802.

2.7  THIS DEVICE REQUIRES SPECIAL HANDLING AND PROCESSING TO PREVENT DAMAGE FROM ELECTROSTATIC DISCHARGE TRANSIENTS.

2.8 REFERENCE:

ASSEMBLY NUMBER 812099-801.  
 A1 ASSEMBLY NUMBER 813732-801.  
 PRINTED WIRING BOARD 412647-1.  
 A2 ASSEMBLY NUMBER 813733-801.  
 PRINTED WIRING BOARD 412648-1.

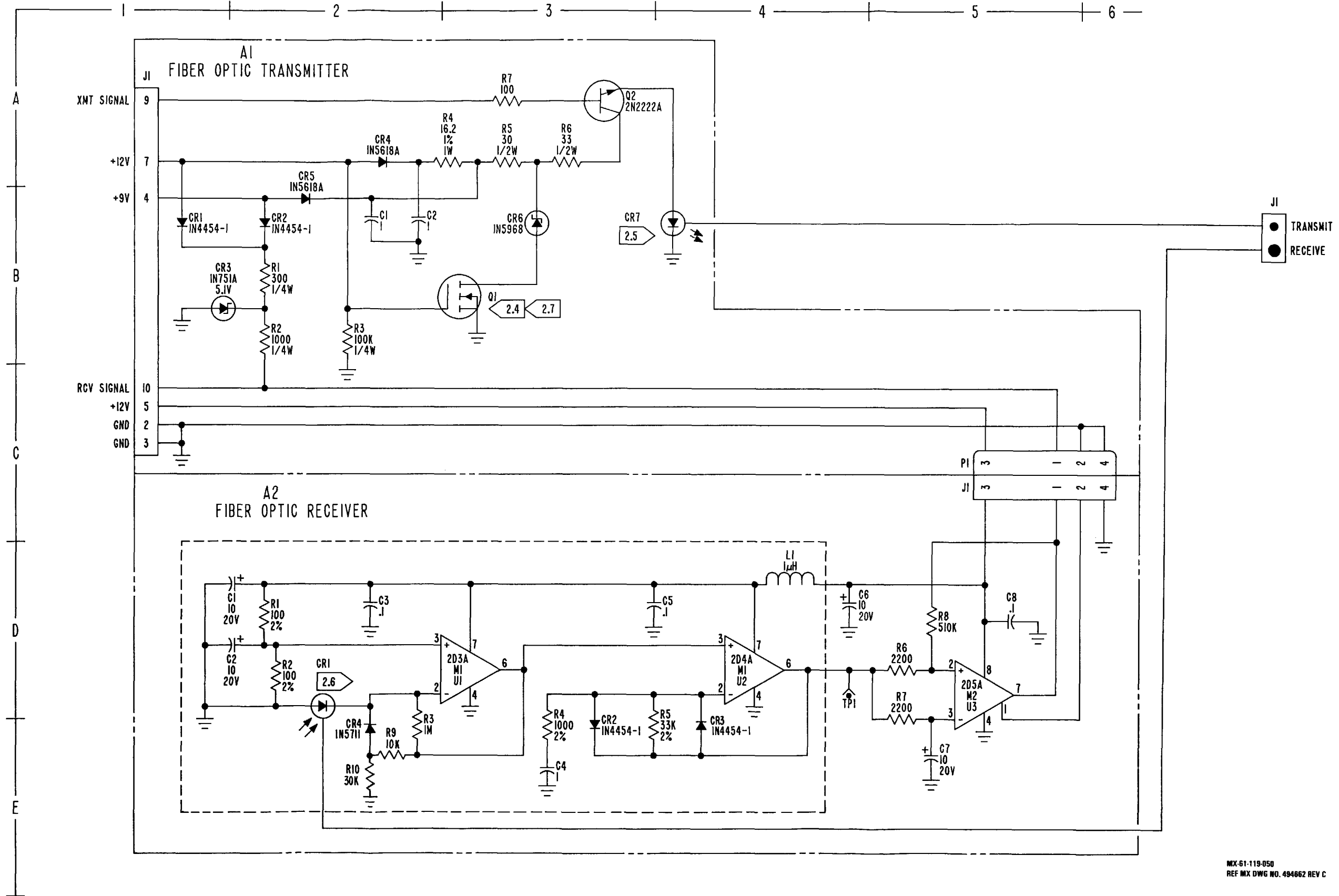

FO-8. Fiber Optic Module Assembly Schematic Diagram



NOTES:

1.0 GENERAL:

- 1.1 INTERPRET DRAWING IN ACCORDANCE WITH STANDARDS PRESCRIBED BY DOD-STD-100.
- 1.2 DATA INCLUDED IN PARENTHESIS, ( ), IS FOR REFERENCE ONLY.
- 1.3 A NUMBER SIGN (#) FOLLOWING A SIGNAL NAME MEANS THE INVERTED (NOT) FORM OF THE SIGNAL.

2.0 SPECIFIC:

- 2.1 UNLESS OTHERWISE SPECIFIED: RESISTANCE VALUES ARE IN OHMS. RESISTORS ARE 5%, 1/8W. CAPACITANCE VALUES ARE IN MICROFARADS. VOLTAGES ARE DC. DIODES AND/OR TRANSISTORS ARE JANTX TYPE.
- 2.2 PARTIAL REFERENCE DESIGNATIONS ARE SHOWN: FOR COMPLETE DESIGNATION PREFIX WITH UNIT NUMBER AND SUBASSEMBLY DESIGNATION 5A2A2 AND 6A2A2.
- 2.3 FOR CONTINUATION OF CIRCUIT SEE SCHEMATIC 493949.
- 2.4 PART NUMBER 616384-905.
- 2.5 PART NUMBER 616494-901.
- 2.6 THIS DEVICE REQUIRES SPECIAL HANDLING AND PROCESSING TO PREVENT DAMAGE FROM ELECTROSTATIC DISCHARGE TRANSIENTS.
- 2.7 REFERENCE: ASSEMBLY NUMBER 812133-801. PRINTED WIRING BOARD 412050-1. TEST SPECIFICATION 918995.

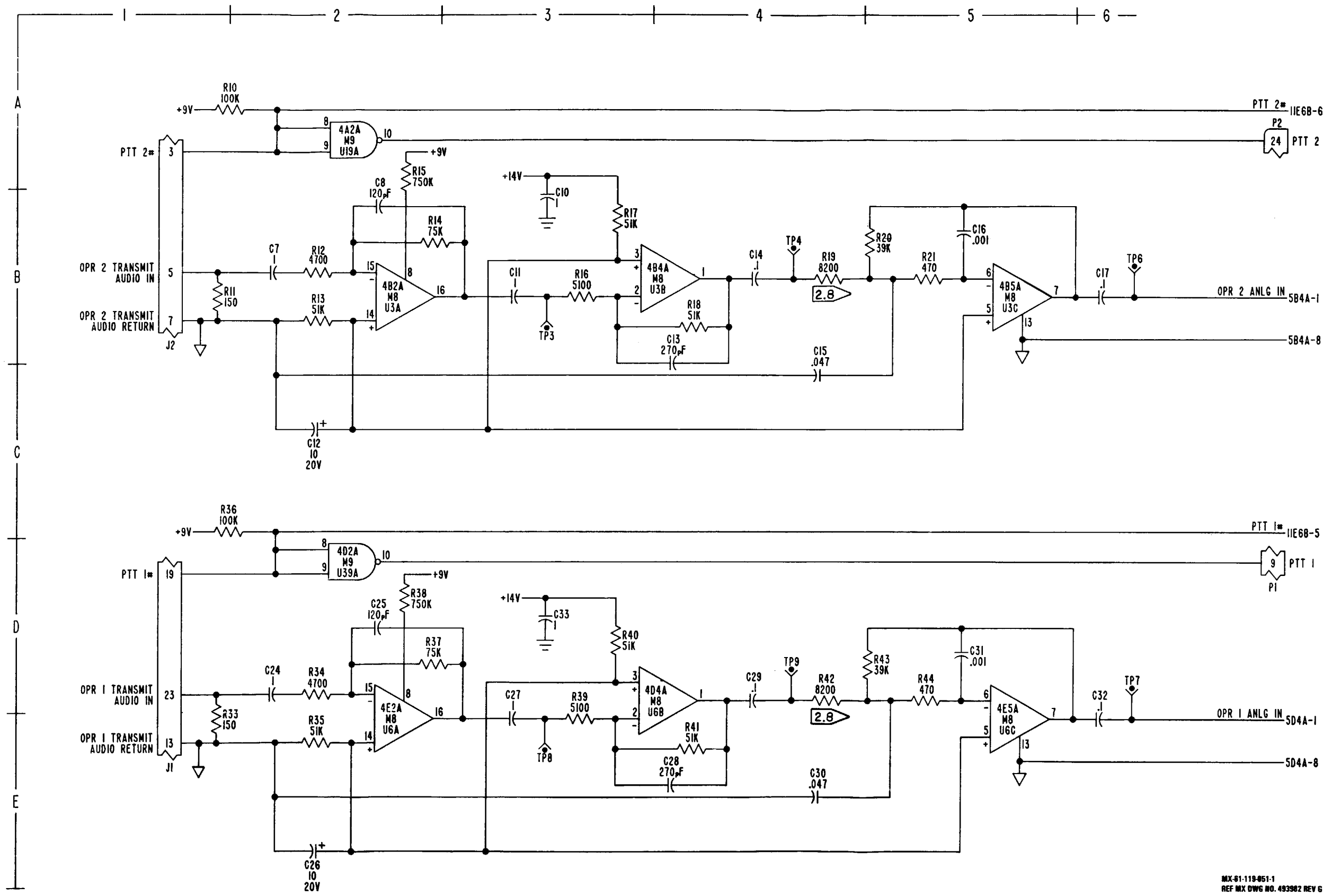
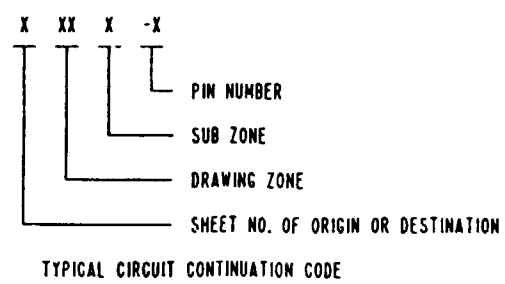

MX-61-119-051-1  
REF MX DWG NO. 493982 REV 6

FO-9. RSC Audio Interface Schematic Diagram (Sheet 1 of 12)



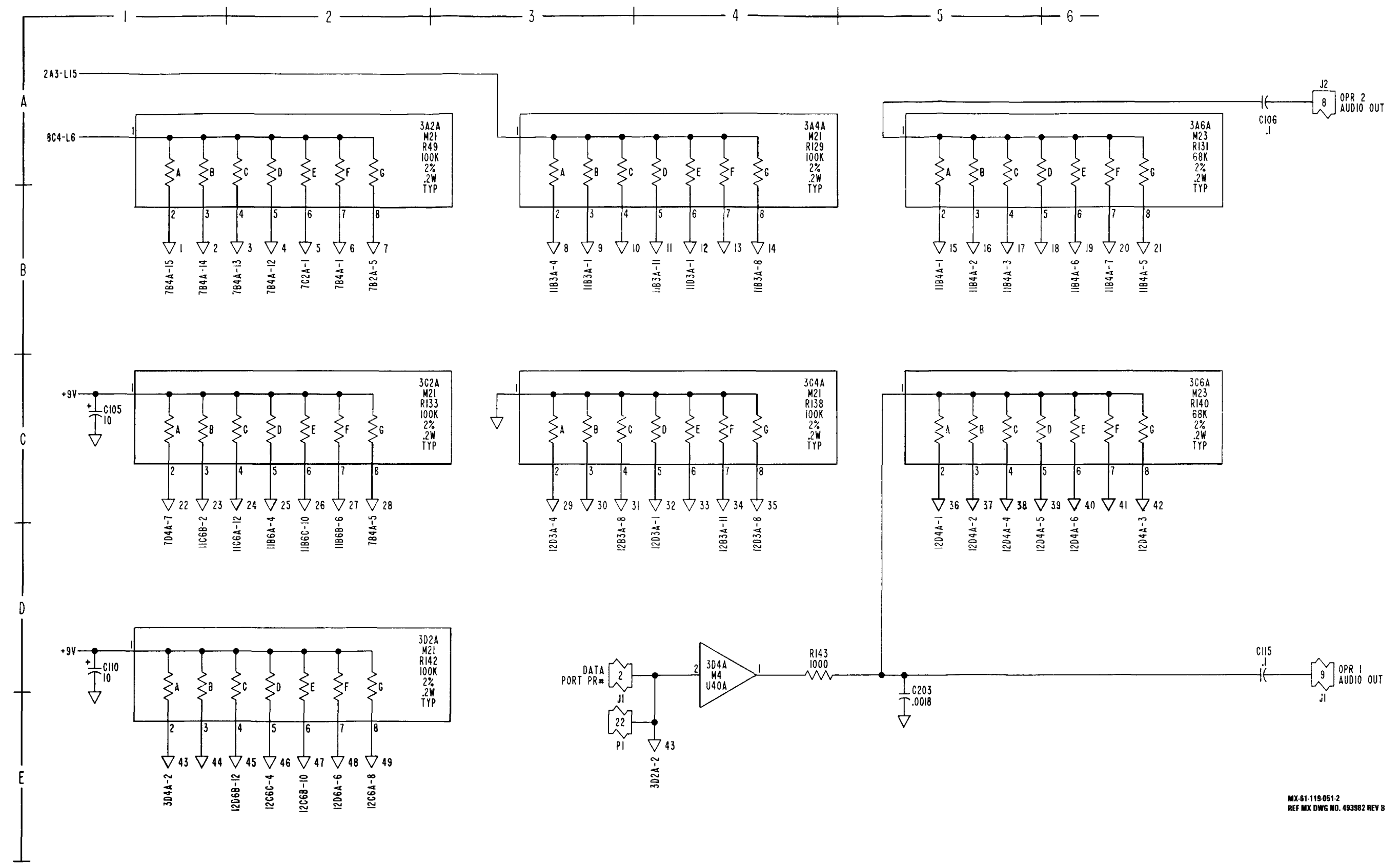

MX-61-119-051-2  
REF MX DWG NO. 493982 REV B

FO-9. RSC Audio Interface Schematic Diagram (Sheet 2 of 12)





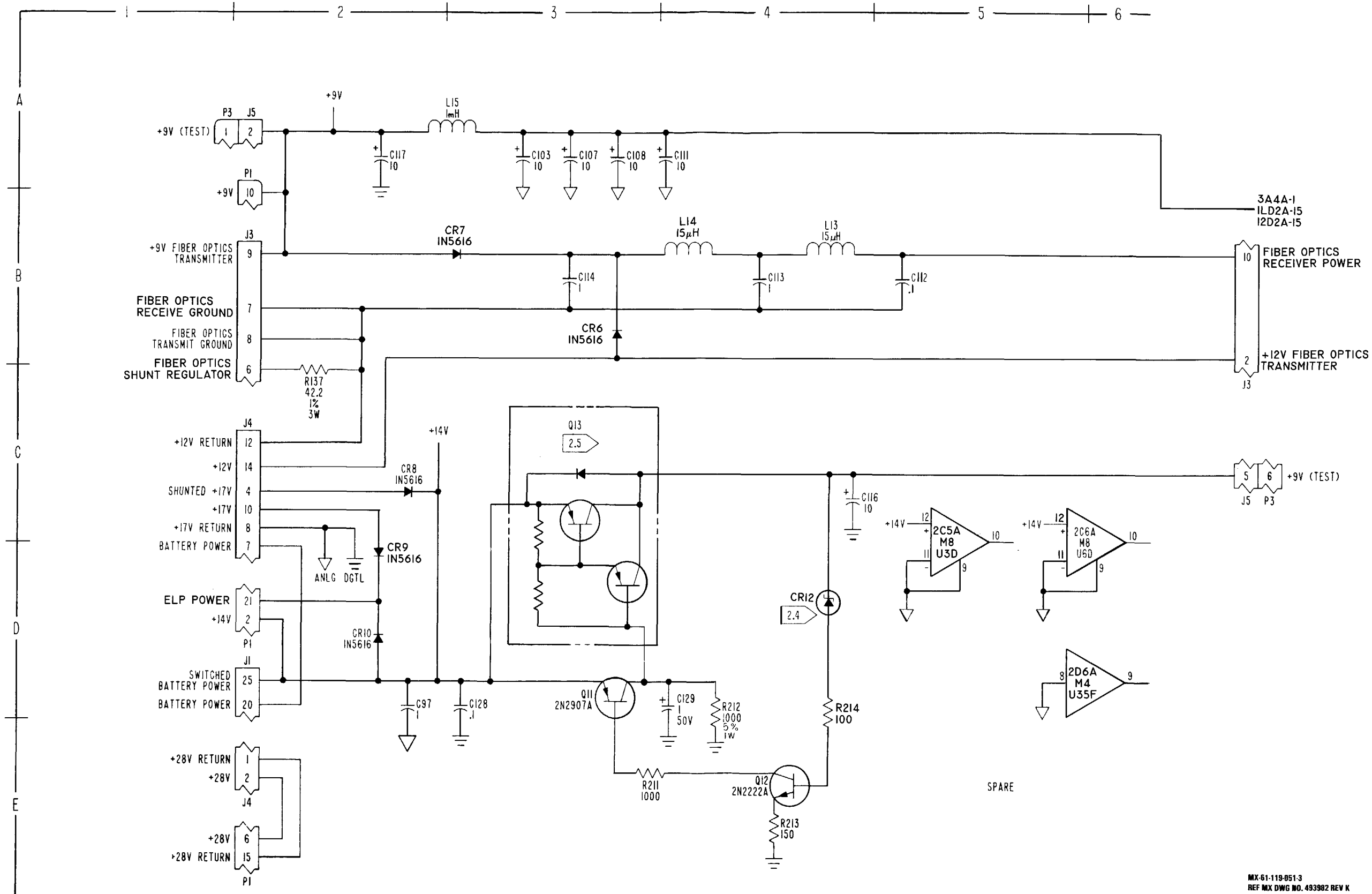

MX-61-119-051-3  
REF MX DWG NO. 493982 REV K

FO-9. RSC Audio Interface Schematic Diagram (Sheet 3 of 12)



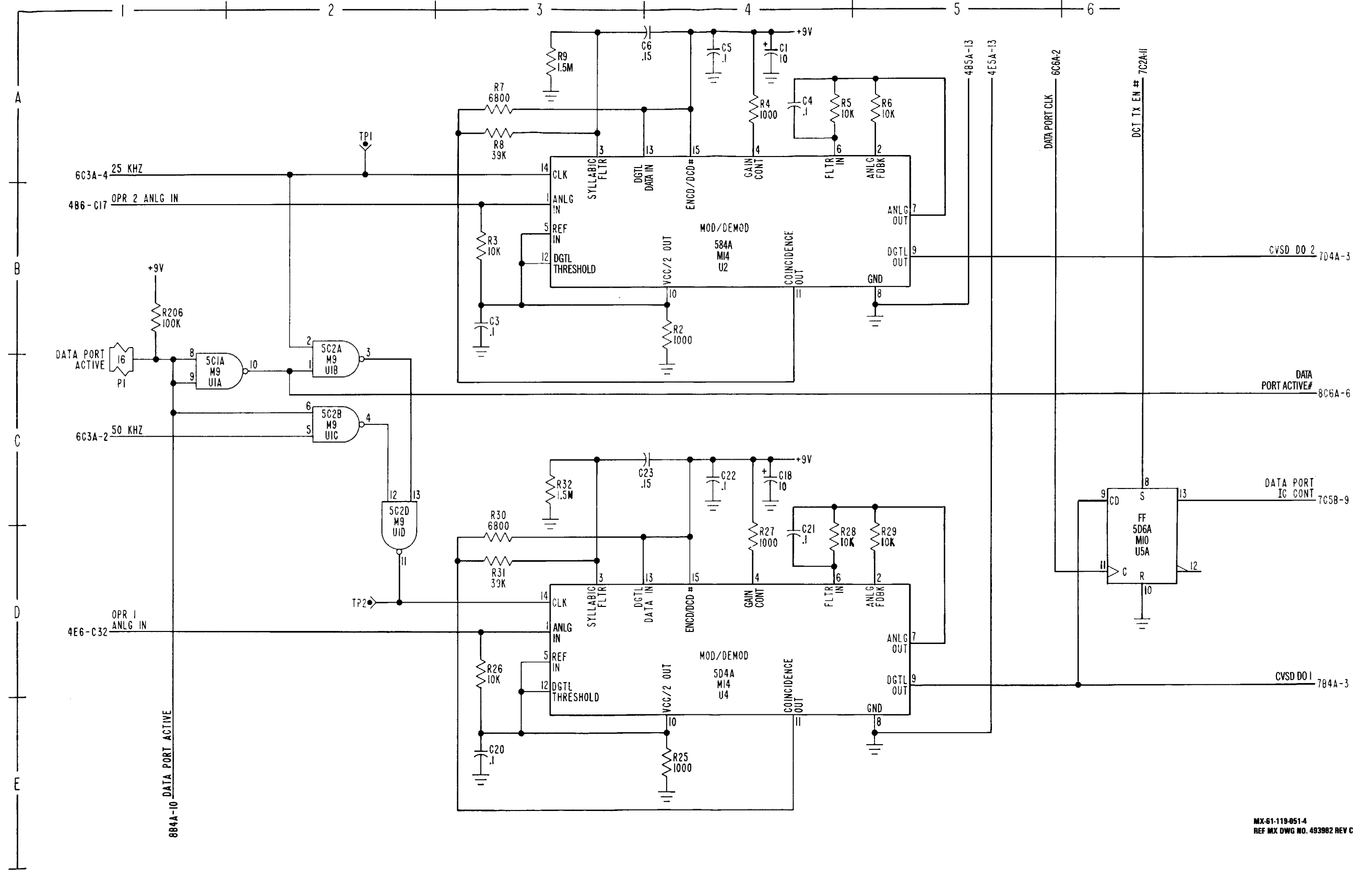

MX-61-119-051-4  
REF MX DWG NO. 493802 REV C

FO-9. RSC Audio Interface Schematic Diagram (Sheet 4 of 12)



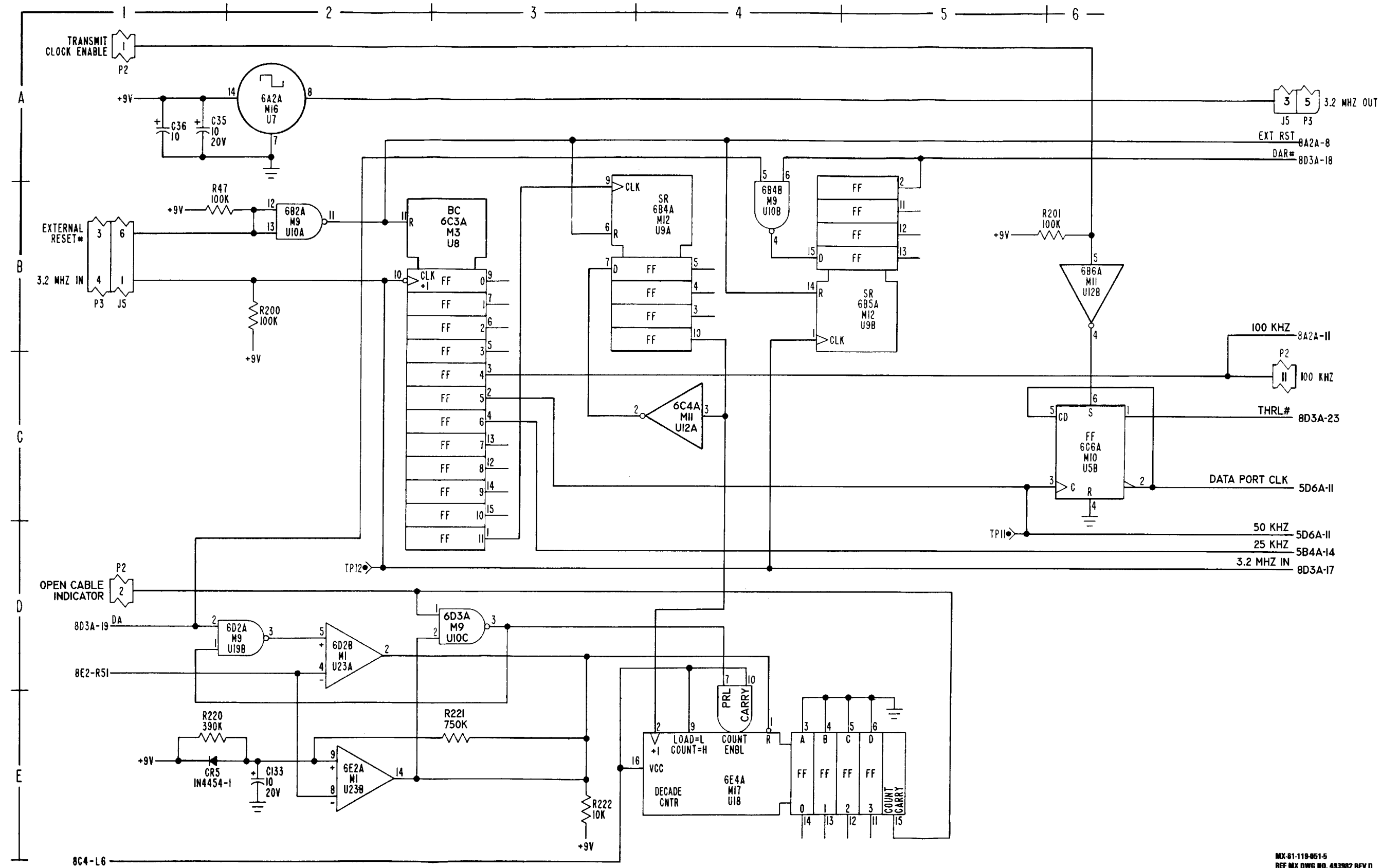

MX-61-119-051-5  
REF MX DWG NO. 493982 REV D

FO-9. RSC Audio Interface Schematic Diagram (Sheet 5 of 12)



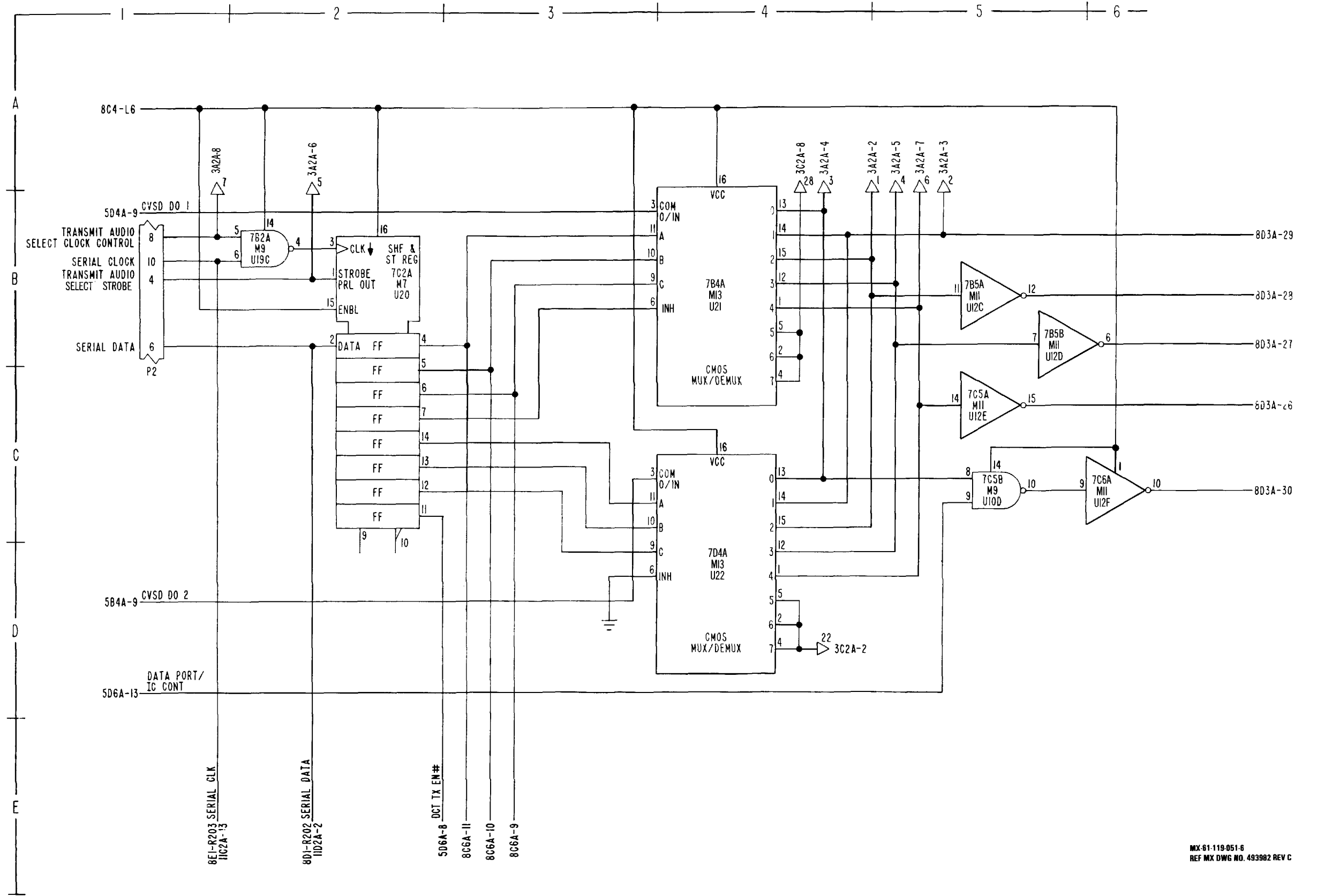

MX-61-119-051-6  
REF MX DWG NO. 493982 REV C

FO-9. RSC Audio Interface Schematic Diagram (Sheet 6 of 12)

FO-95/(FO-96 blank)





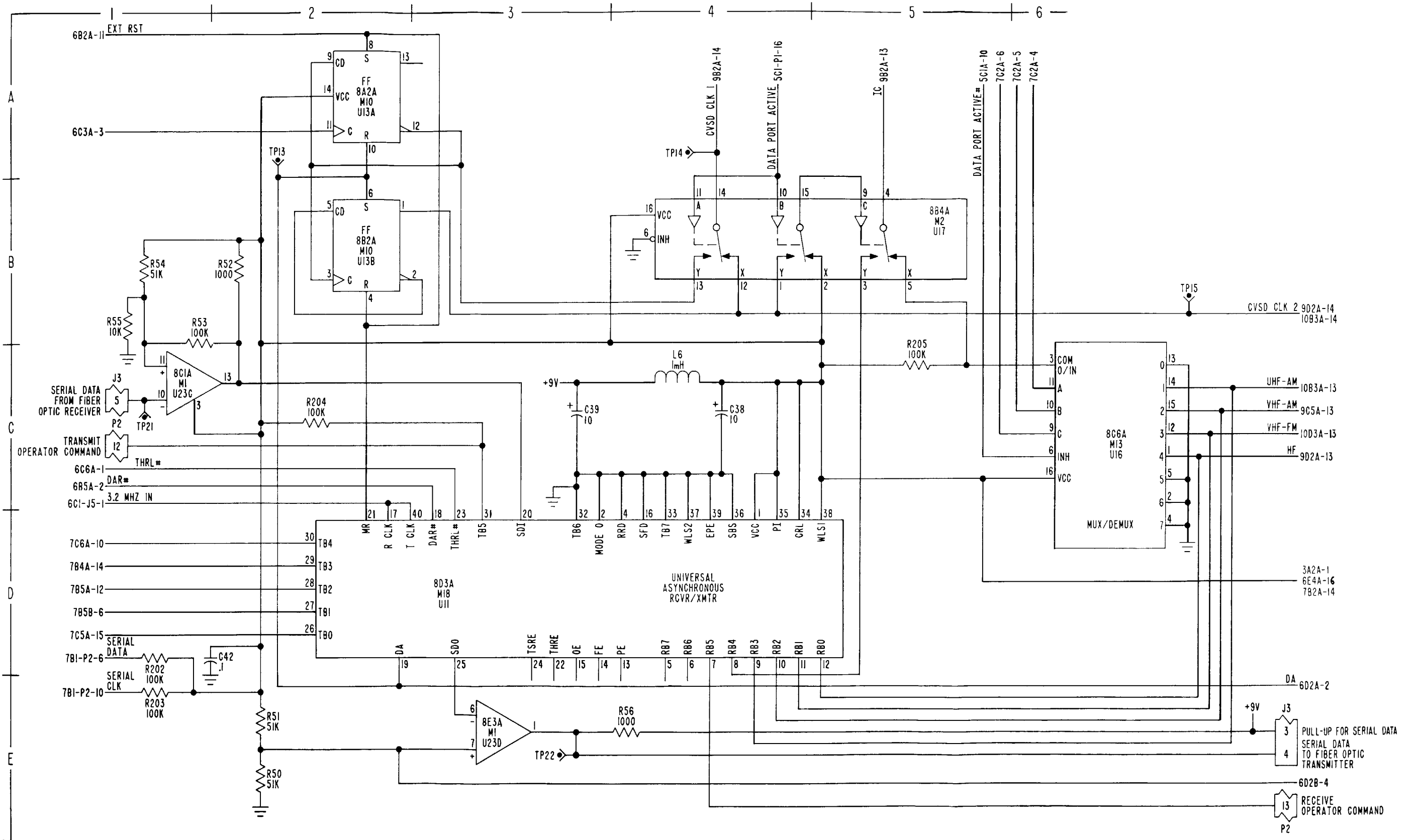

MX-81-119-051-7  
REF MX DWG NO. 493982 REV B

FO-9. RSC Audio Interface Schematic Diagram (Sheet 7 of 12)



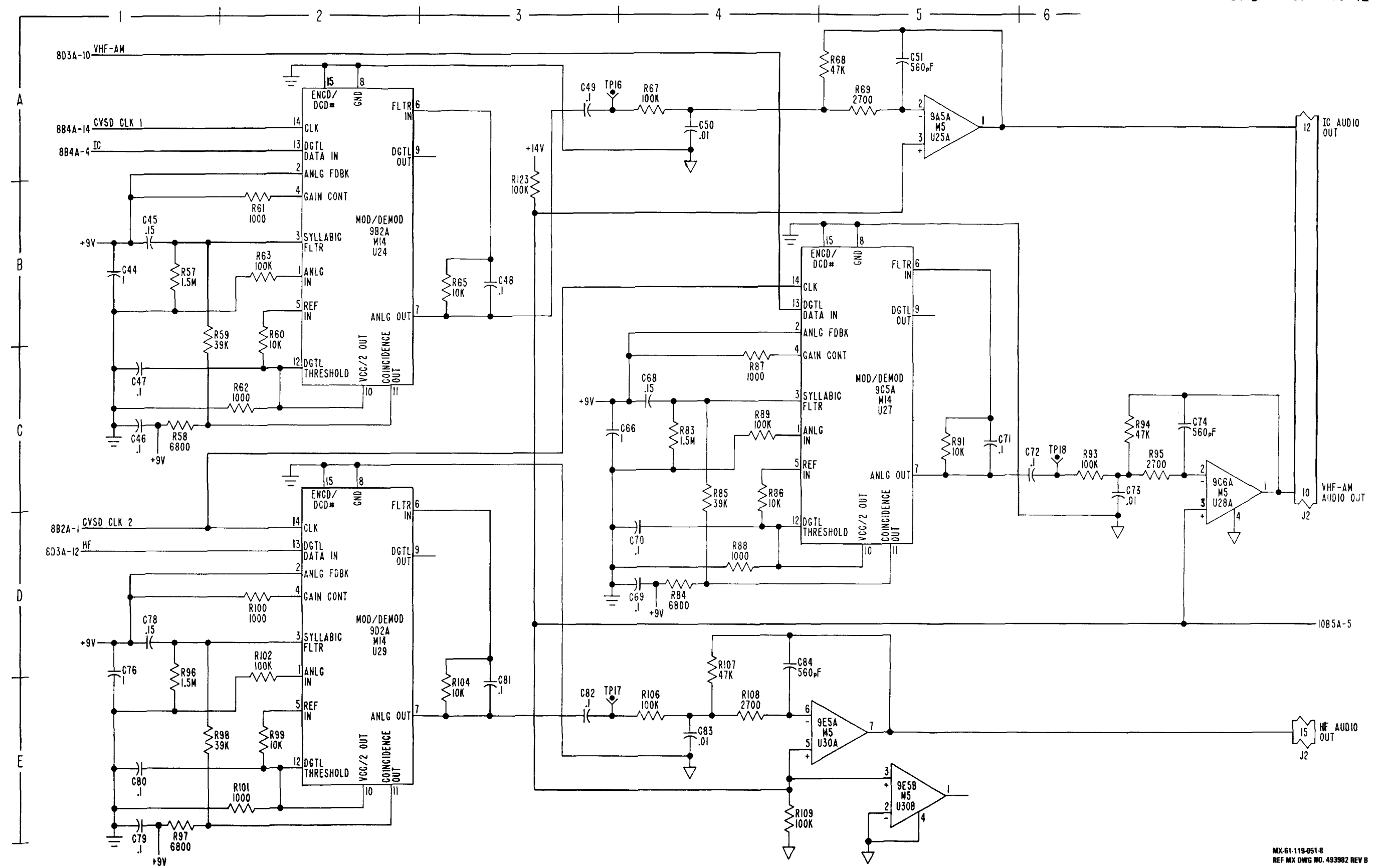

MX-61-119-051-B  
REF MX DWG NO. 493982 REV B

FO-9. RSC Audio Interface Schematic Diagram (Sheet 8 of 12)



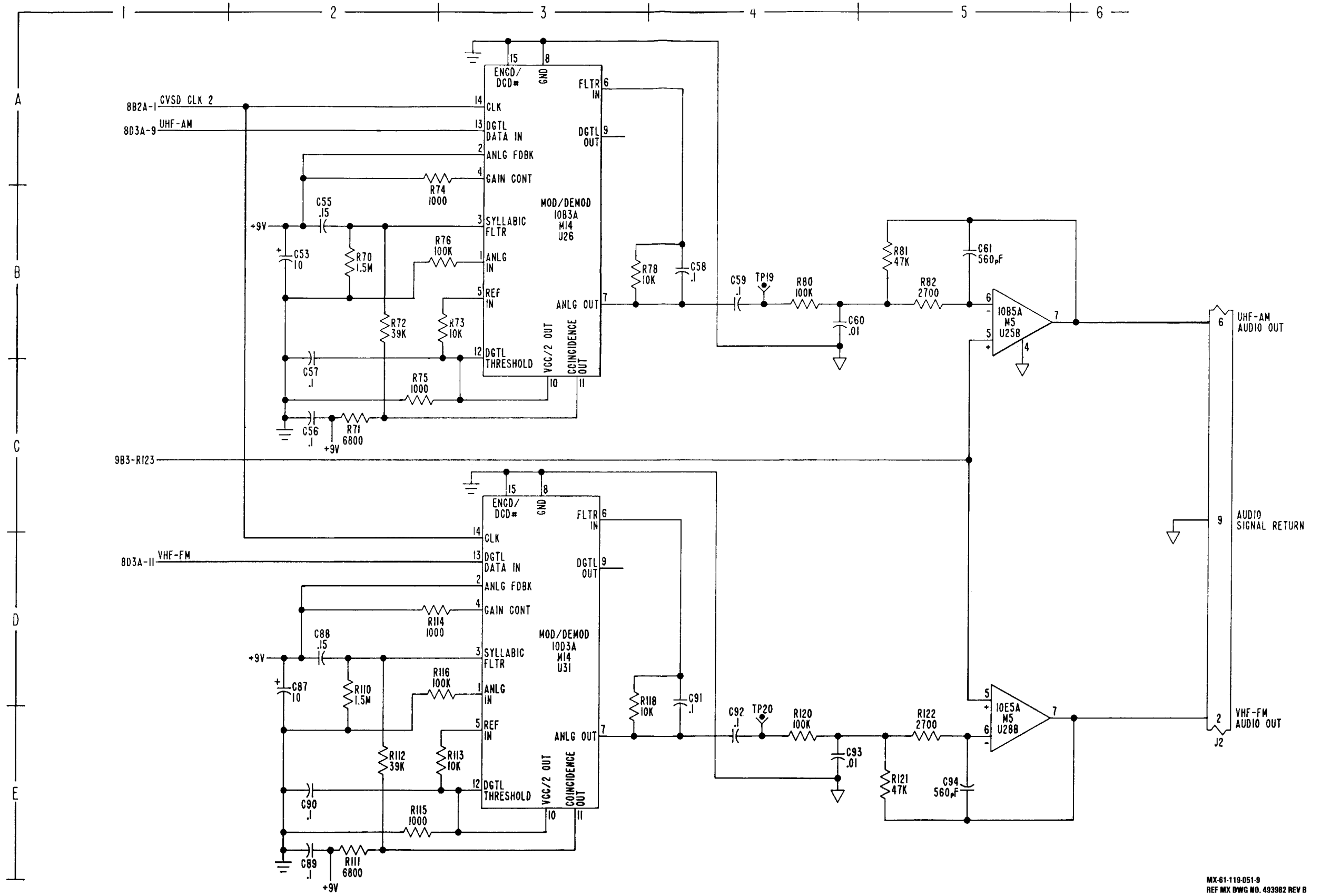

MX-61-119-051-9  
REF MX DWG NO. 493982 REV B

FO-9. RSC Audio Interface Schematic Diagram (Sheet 9 of 12)

FO-101/(FO-102 blank)



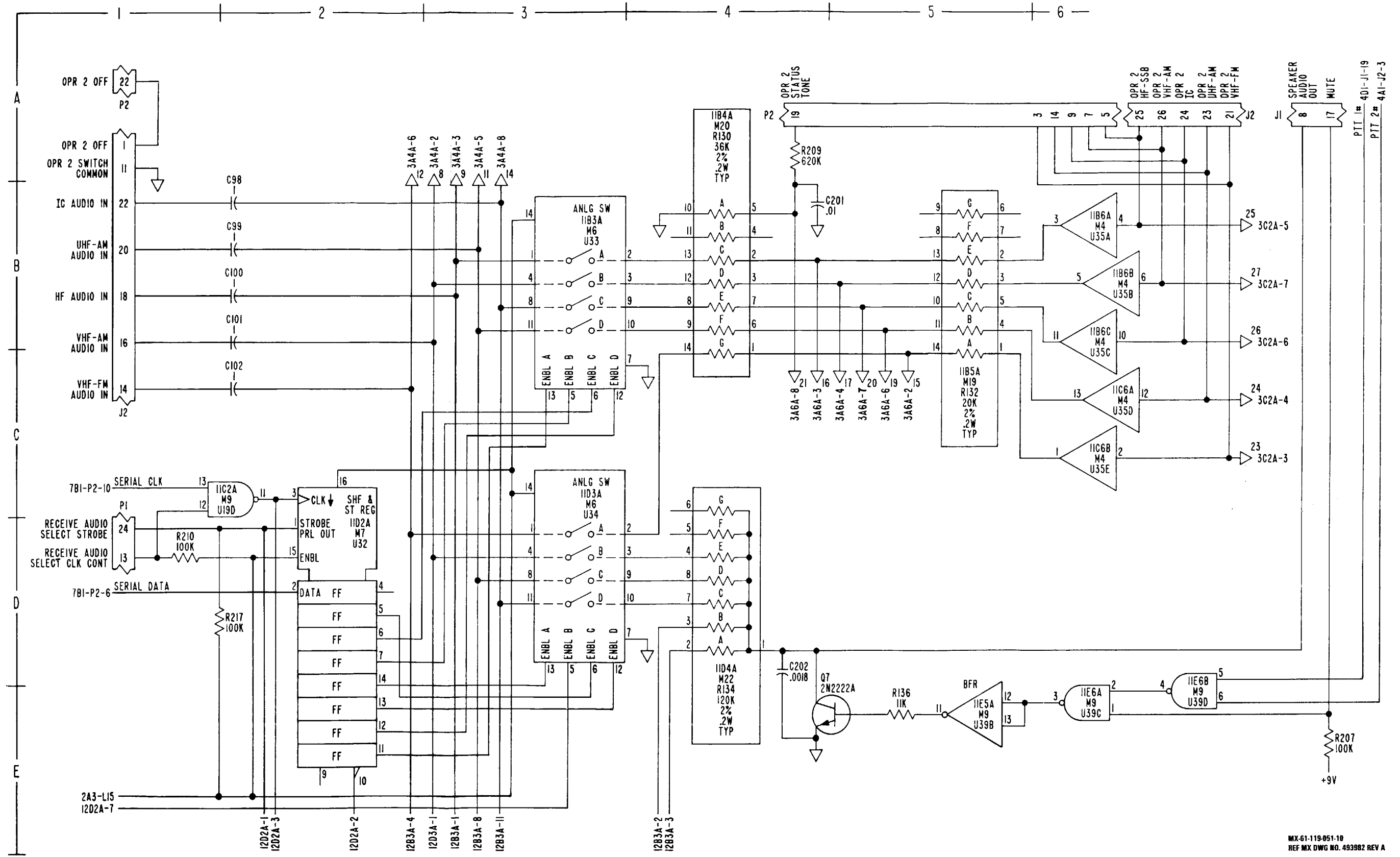

MX-61-119-051-10  
REF MX DWG NO. 493982 REV A

FO-9. RSC Audio Interface Schematic Diagram (Sheet 10 of 12)





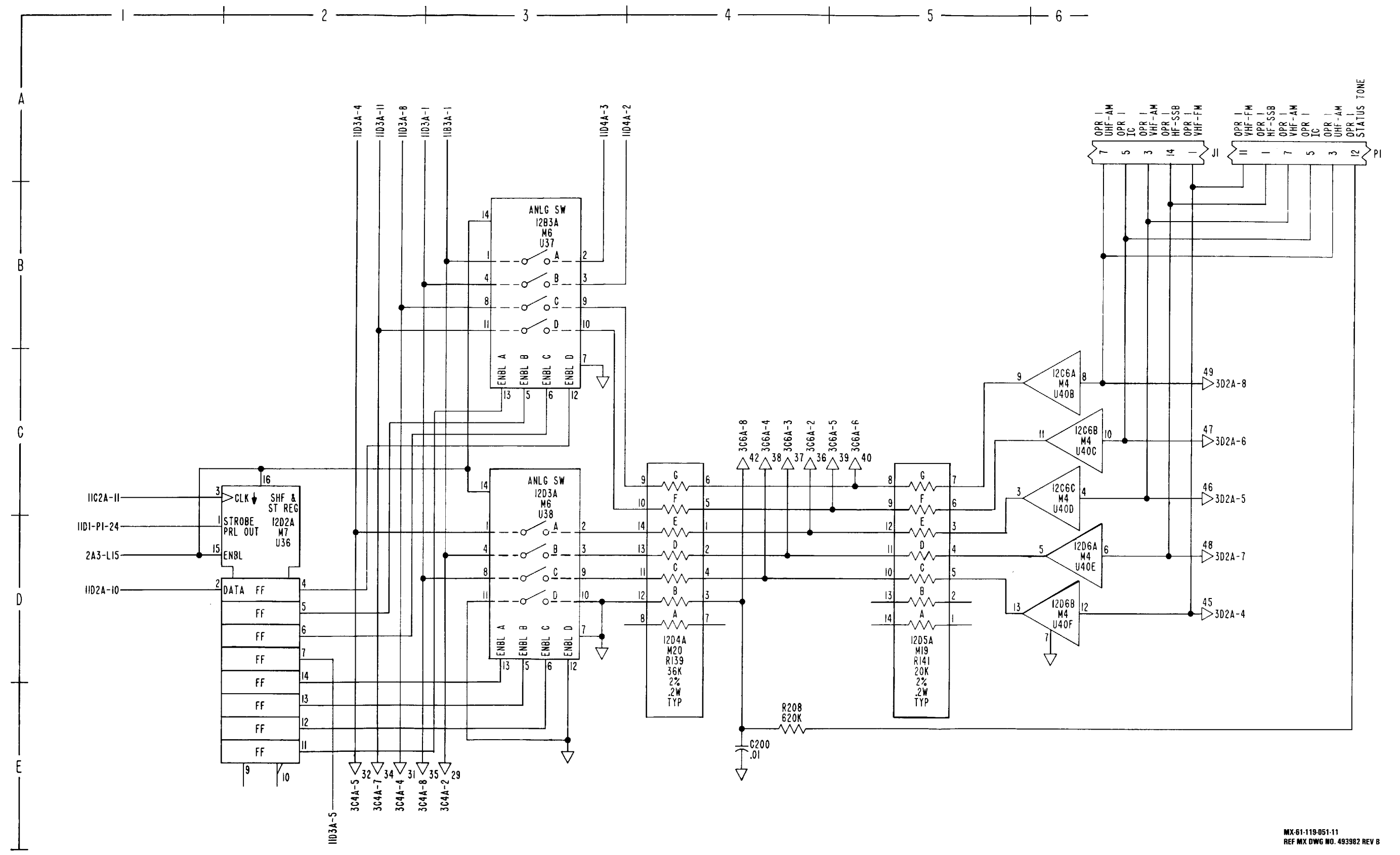

MX-61-119-051-11  
REF MX DWG NO. 493982 REV B

FO-9. RSC Audio Interface Schematic Diagram (Sheet 11 of 12)



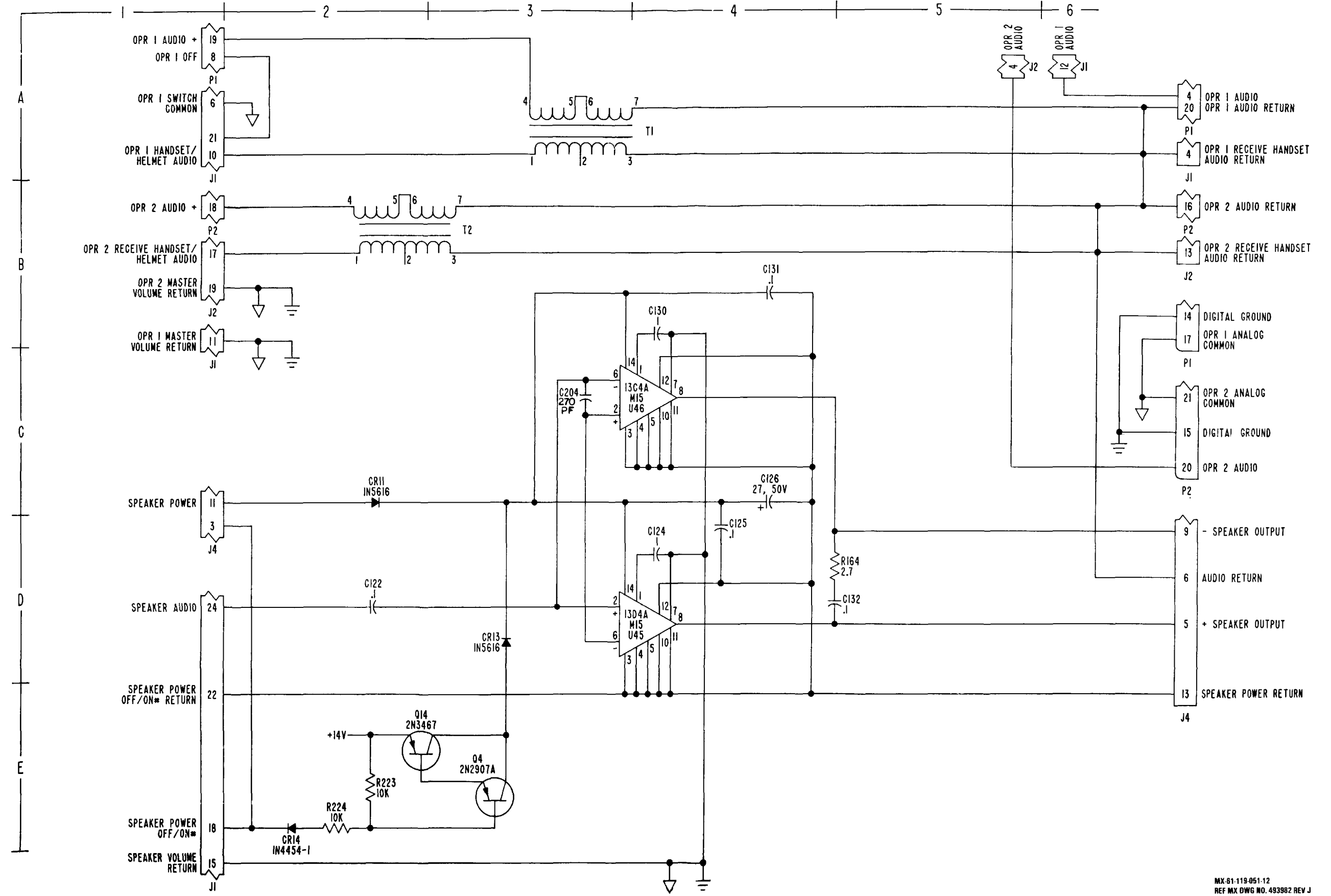

MX-61-119-051-12  
REF MX DWG NO. 493982 REV J

FO-9. RSC Audio Interface Schematic Diagram (Sheet 12 of 12)



| INTEGRATED CIRCUIT TABLE  |                         |                  |                  |      |     |  |
|---------------------------|-------------------------|------------------|------------------|------|-----|--|
| REFERENCE DESIGNATION     | SECOND TAGGING LINE SYM | PART NUMBER      | POWER INPUT PINS |      |     |  |
|                           |                         |                  | +9V              | +14V | GND |  |
| 2.6 U13                   | M1                      | JM38510/17602BJX | 24               | NA   | 12  |  |
| U8                        | M2                      | JM38510/11201BCX | NA               | 3    | 12  |  |
| 2.6 U22                   | M3                      | 7705801EX        | 16               | NA   | 8   |  |
| U11,12                    | M4                      | 615747-901       | 16               | NA   | 8   |  |
| 2.6 U6,7,32               | M5                      | JM38510/17001BCX | 14               | NA   | 7   |  |
| 2.6 U15,42,45             | M6                      | JM38510/17505BEX | 16               | NA   | 8   |  |
| 2.6 U31                   | M7                      | 7702501EX        | 16               | NA   | 8   |  |
| 2.6 U35                   | M8                      | JM38510/17305BEX | 16               | NA   | 8   |  |
| 2.6 U19,33                | M9                      | JM38510/05051BCX | 14               | NA   | 7   |  |
| 2.6 U37                   | M10                     | 616492-903       | 14               | NA   | 7   |  |
| 2.6 U10,34,38             | M11                     | JM38510/05151BCX | 14               | NA   | 7   |  |
| 2.6 U9                    | M12                     | JM38510/17203BCX | 14               | NA   | 7   |  |
| 2.6 U20                   | M13                     | JM38510/05553BEX | 1                | NA   | 8   |  |
| 2.6 U16                   | M14                     | 7901201EX        | 16               | NA   | 8   |  |
| 2.6 U18                   | M15                     | JM38510/05753BEX | 16               | NA   | 8   |  |
| U24,26                    | M16                     | 619905-901       | NA               | 14   | NA  |  |
| 2.6 U1,2,3,4,5            | M17                     | 645448-901       | 20               | NA   | 1   |  |
| 2.6 U40,41,44             | M18                     | 645460-901       | 24,19            | NA   | 12  |  |
| 2.6 U17                   | M19                     | JM38510/17301BJX | 24               | NA   | 12  |  |
| 2.6 U21,36,39             | M20                     | 645513-901       | 16               | NA   | 8   |  |
| 2.6 U29,30                | M21                     | 645514-901       | 16               | NA   | 8   |  |
| 2.6 U14                   | M22                     | JM38510/47501BXX | 1                | NA   | 3   |  |
| 2.6 U27,28                | M23                     | JM38510/05756BJX | 24               | NA   | 12  |  |
| 2.6 R17,18,19,25,27,33,35 | M24                     | M8340105M10036C  | NA               | NA   | NA  |  |

| REF DESIGNATION |                     |
|-----------------|---------------------|
| HIGHEST USED    | NOT USED            |
| C26             | C4-6,12,15,21,23,24 |
| CR5             |                     |
| DS8             |                     |
| XDS8            |                     |
| HR4             |                     |
| J4              |                     |
| L1              |                     |
| Q3              |                     |
| R39             | R16,23,24,26,36     |
| TP36            | TP24                |
| U45             | U23,25,43           |

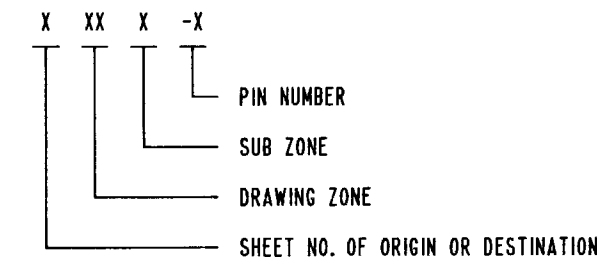

TYPICAL CIRCUIT CONTINUATION CODE

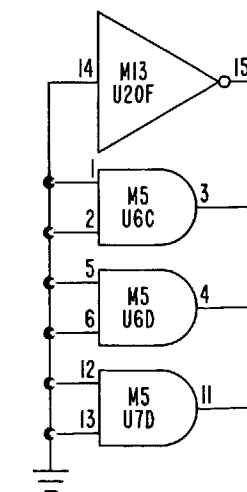

SPARES

NOTES:

- 1.0 GENERAL:
  - 1.1 INTERPRET DRAWING IN ACCORDANCE WITH STANDARDS PRESCRIBED BY DOD-STD-100.
  - 1.2 DATA INCLUDED IN PARENTHESIS, ( ), IS FOR REFERENCE ONLY.
  - 1.3 A NUMBER SIGN (\*) FOLLOWING A SIGNAL NAME MEANS THE INVERTED (NOT) FORM OF THE SIGNAL.
- 2.0 SPECIFIC:
  - 2.1 UNLESS OTHERWISE SPECIFIED:-  
 RESISTORS ARE IN OHMS.  
 RESISTORS ARE 5%, 1/8W.  
 CAPACITANCE VALUES ARE IN MICROFARADS.  
 VOLTAGES ARE DC.  
 DIODES AND/OR TRANSISTORS ARE JANTX TYPE.
  - 2.2 PARTIAL REFERENCE DESIGNATIONS ARE SHOWN: FOR COMPLETE DESIGNATION PREFIX WITH UNIT NUMBER AND SUBASSEMBLY DESIGNATION 5A2A1,6A2A1.
  - 2.3 FOR CONTINUATION OF CIRCUIT SEE SCHEMATIC 493949.
  - 2.4 PART NUMBER 616384-905.
  - 2.5 PART NUMBER 617713-902.
  - 2.6 THIS DEVICE REQUIRES SPECIAL HANDLING AND PROCESSING TO PREVENT DAMAGE FROM ELECTROSTATIC DISCHARGE TRANSIENTS.
  - 2.7 VALUE SELECTED AT TEST, NOMINAL VALUE SHOWN.
  - 2.8 REFERENCE:  
 ASSEMBLY NUMBER 812126-801.  
 PRINTED WIRING BOARD 412045-1.



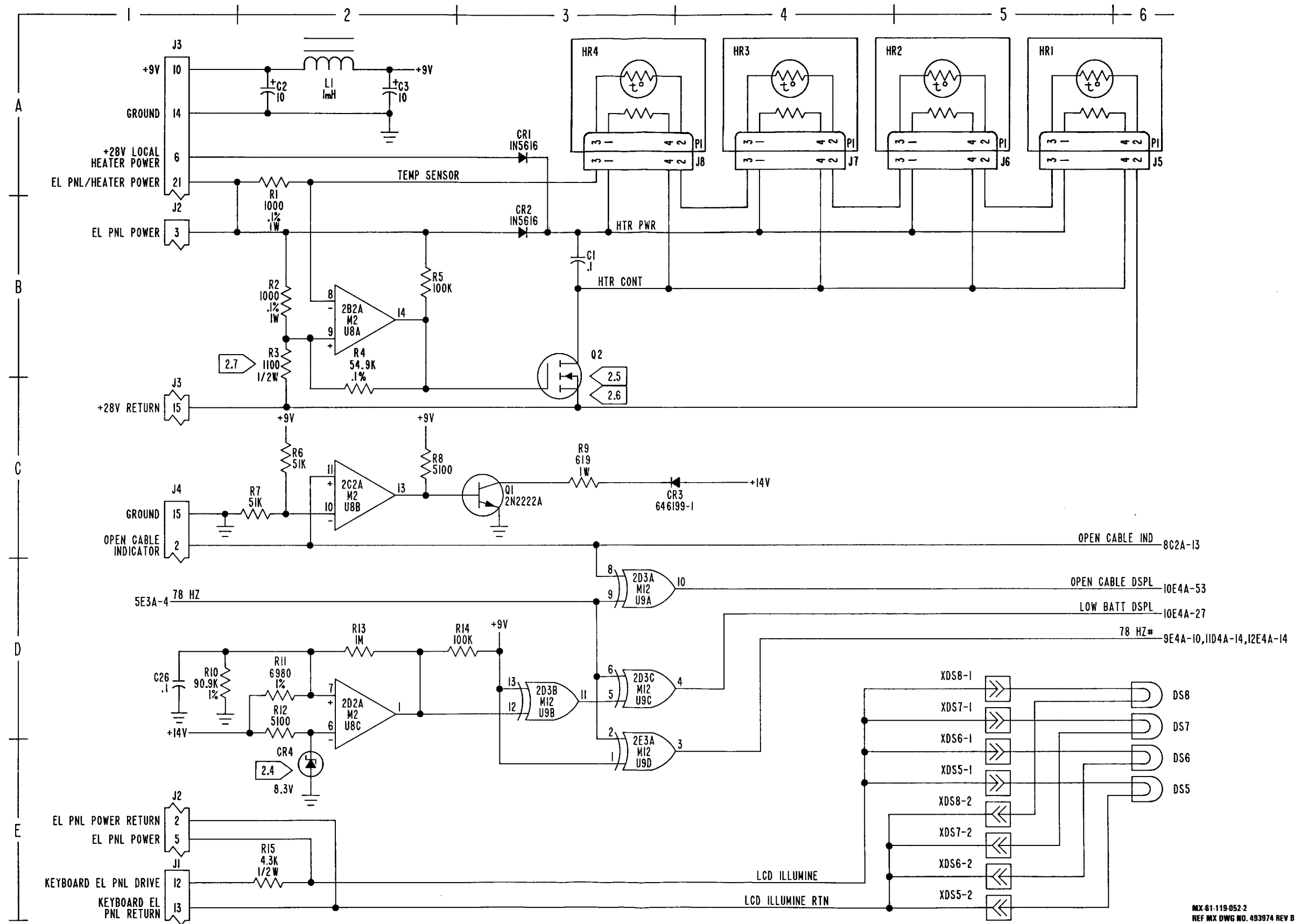

MX-61-119-052 2  
REF MX DWG NO. 493974 REV B

FO-10. RSC Digital Interface Schematic Diagram (Sheet 2 of 12)





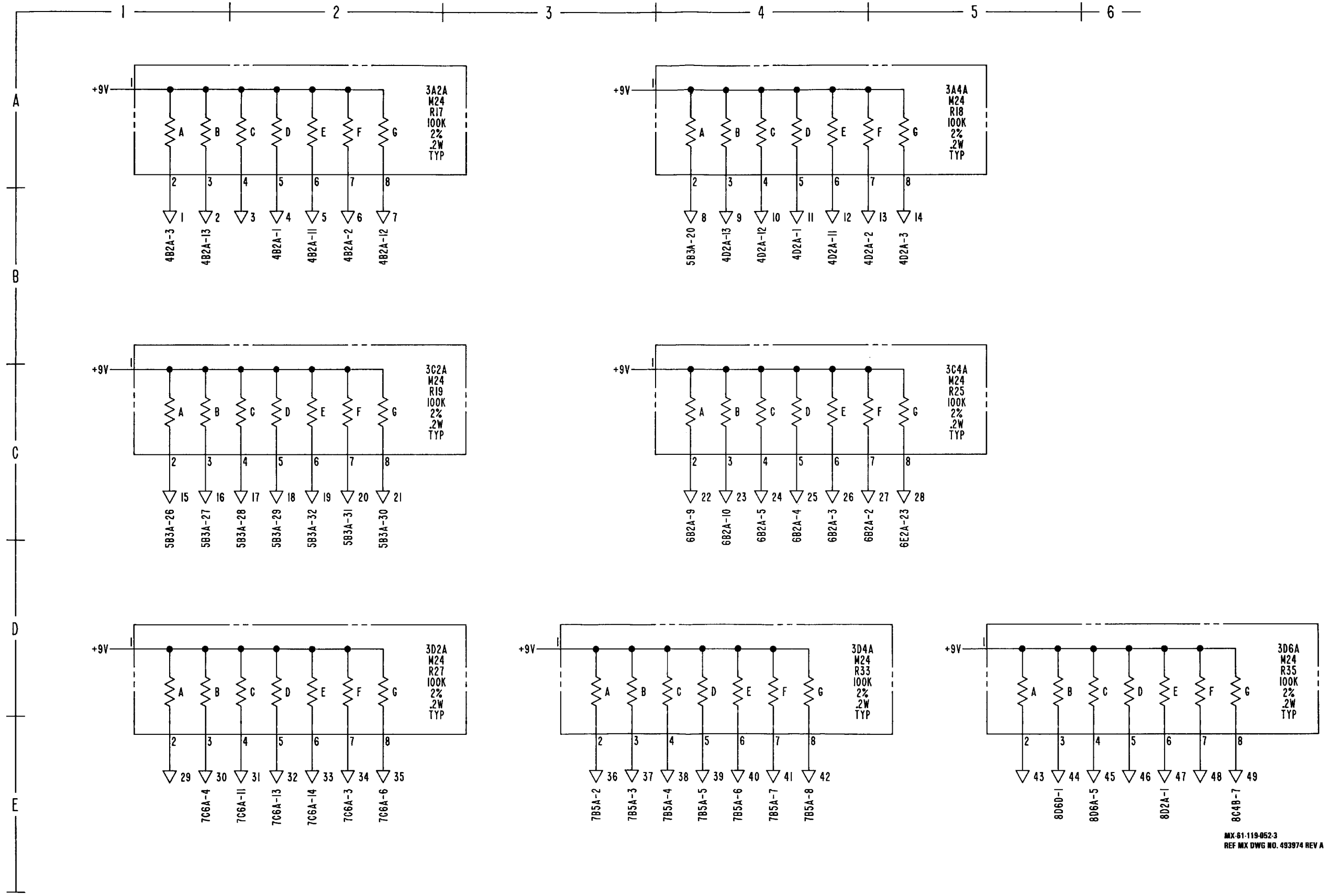

MX-61-119-062-3  
REF MX DWG NO. 493974 REV A

FO-10. RSC Digital Interface Schematic Diagram (Sheet 3 of 12)

FO-113/(FO-114 blank)



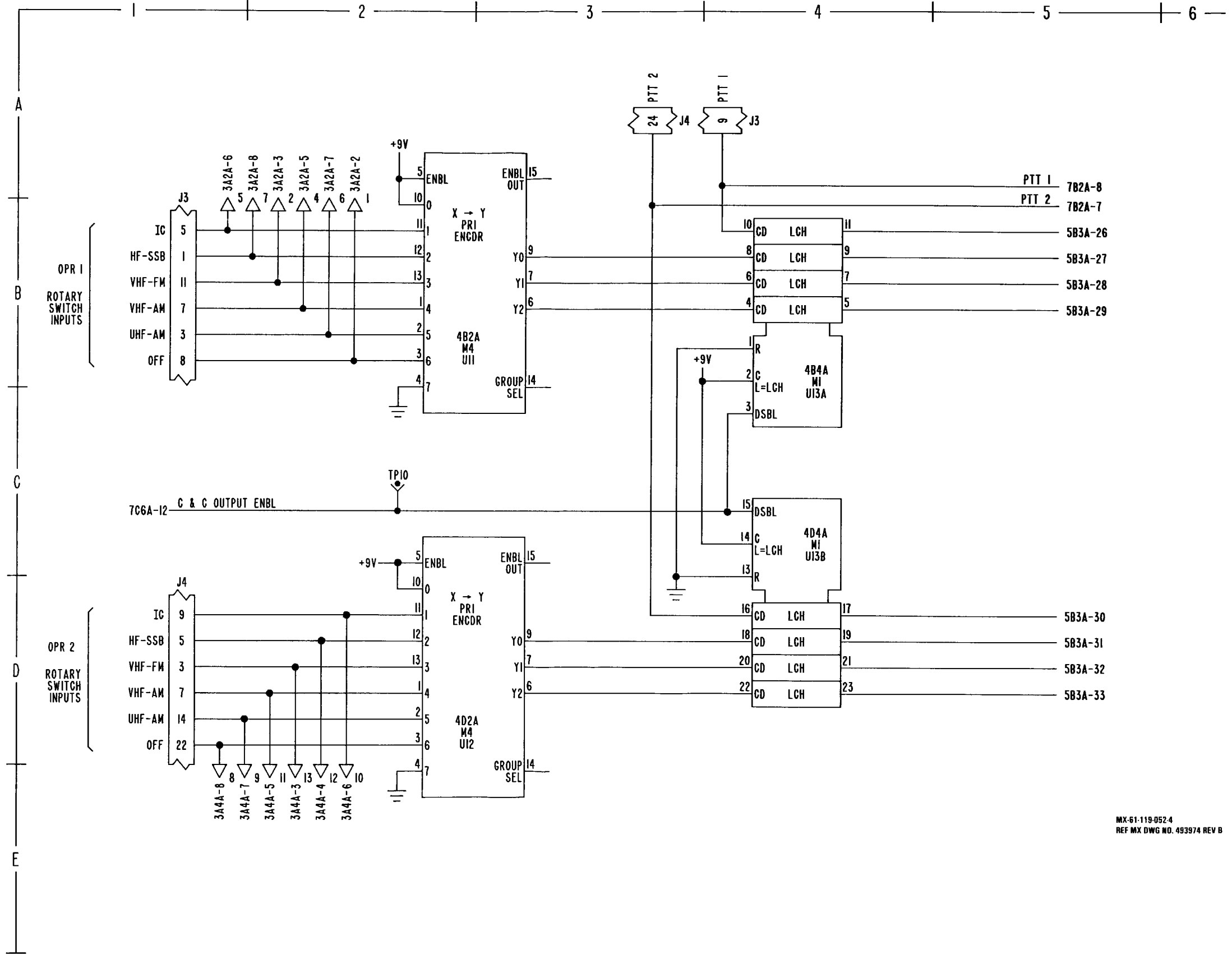

MX-61-119-052-4  
REF MX DWG NO. 493974 REV B

FO-10. RSC Digital Interface Schematic Diagram (Sheet 4 of 12)



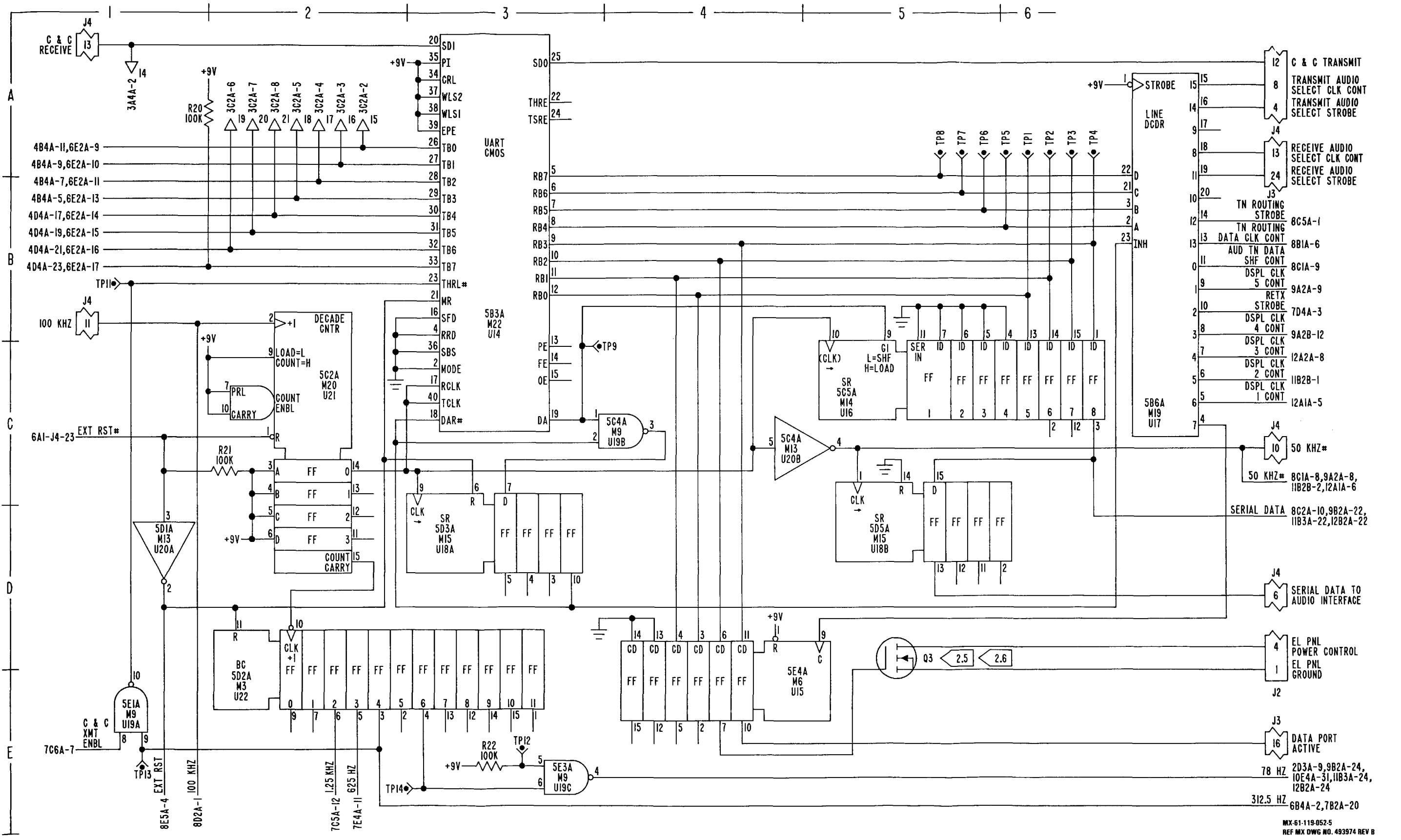

FO-10. RSC Digital Interface Schematic Diagram (Sheet 5 of 12)



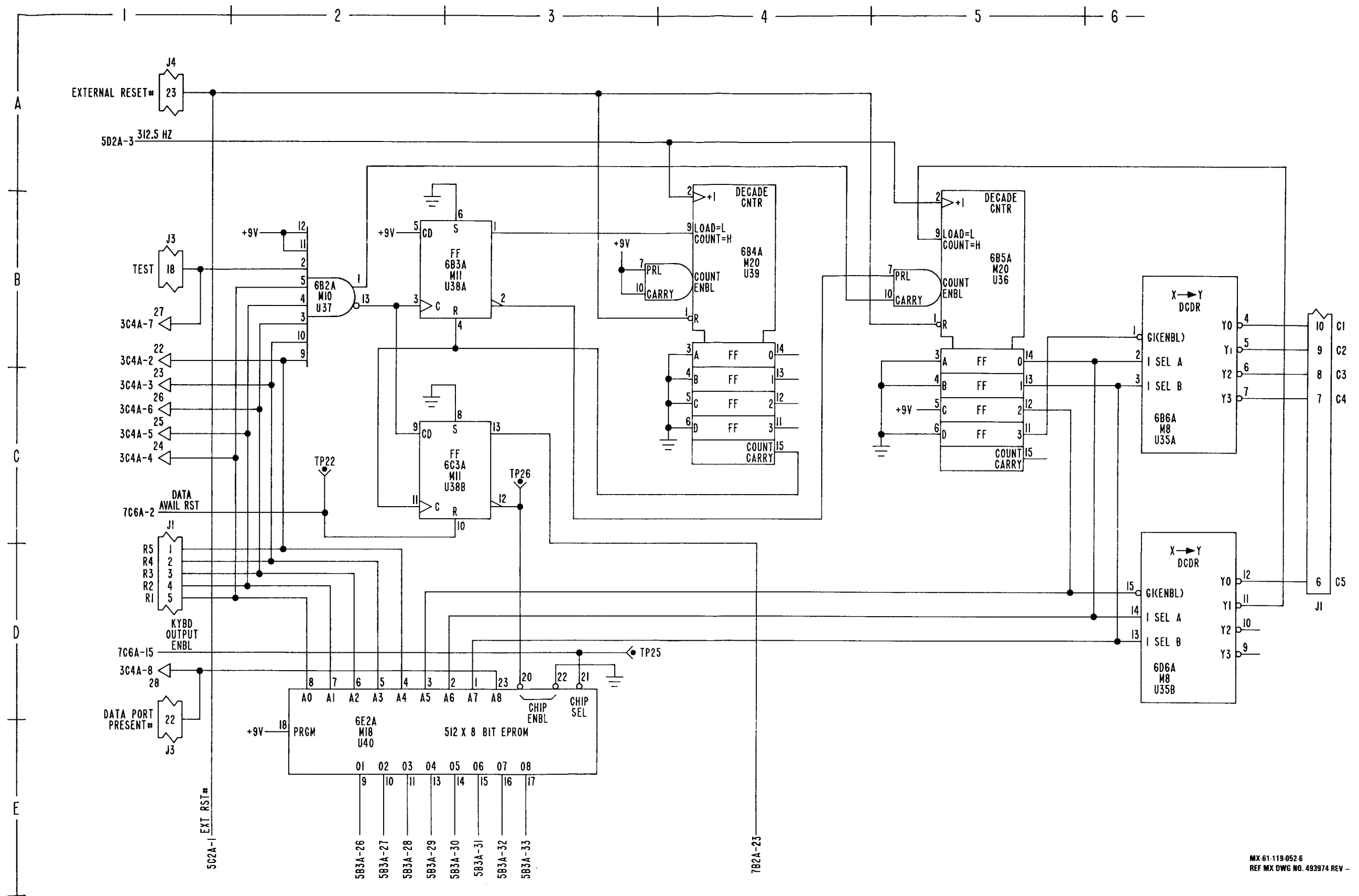

MX 61-119-052.6  
REF MX DWG NO. 493974 REV -

FO-10. RSC Digital Interface Schematic Diagram (Sheet 6 of 12)





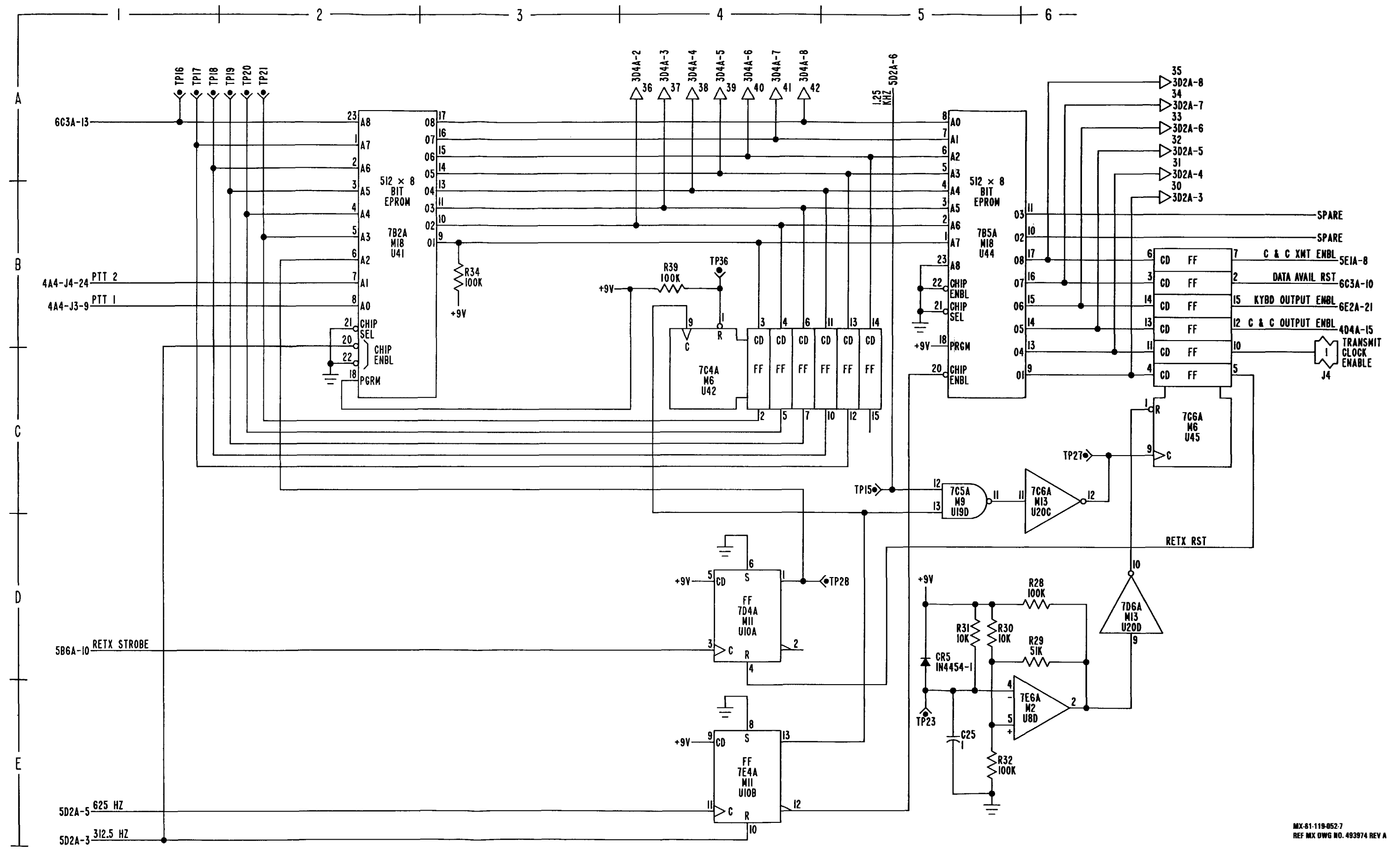

MX-81-119-052-7  
REF MX DWG NO. 493974 REV A

FO-10. RSC Digital Interface Schematic Diagram (Sheet 7 of 12)



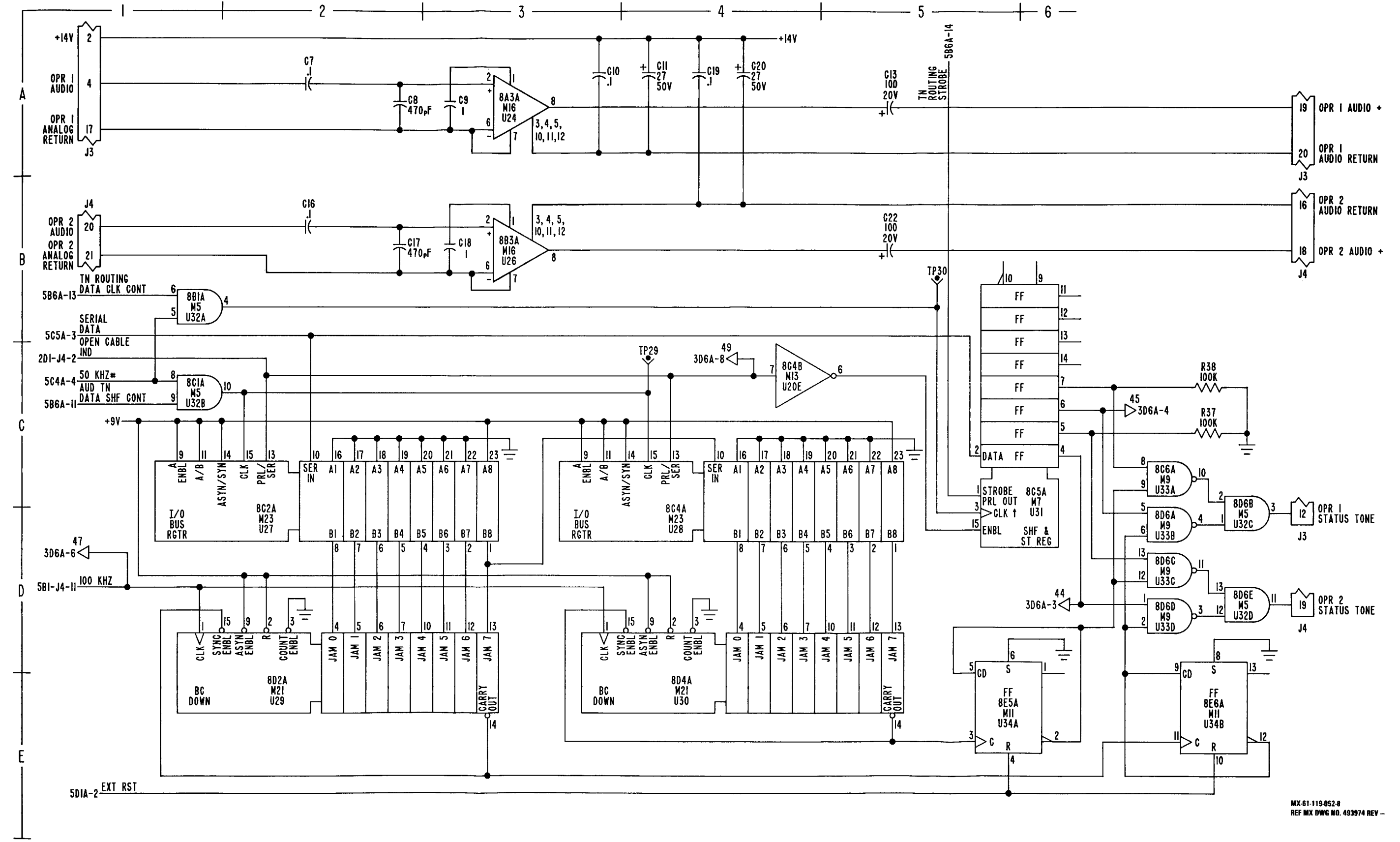

FO-10. RSC Digital Interface Schematic Diagram (Sheet 8 of 12)

MX-61-119-052-8  
REF MX DWG NO. 493974 REV -



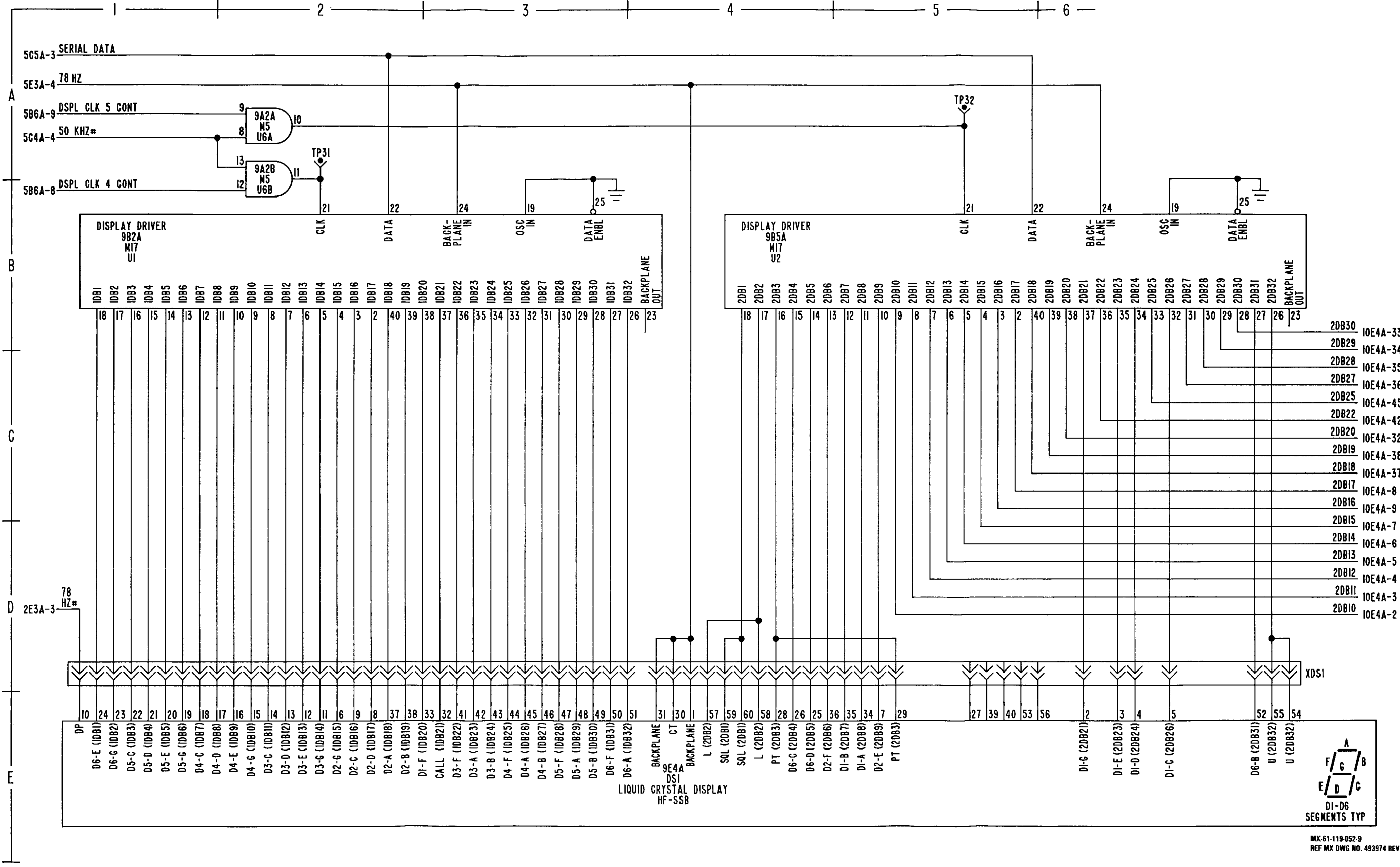

FO-10. RSC Digital Interface Schematic Diagram (Sheet 9 of 12)

MX-61-119-0529 REF MX DWG NO. 493974 REV -



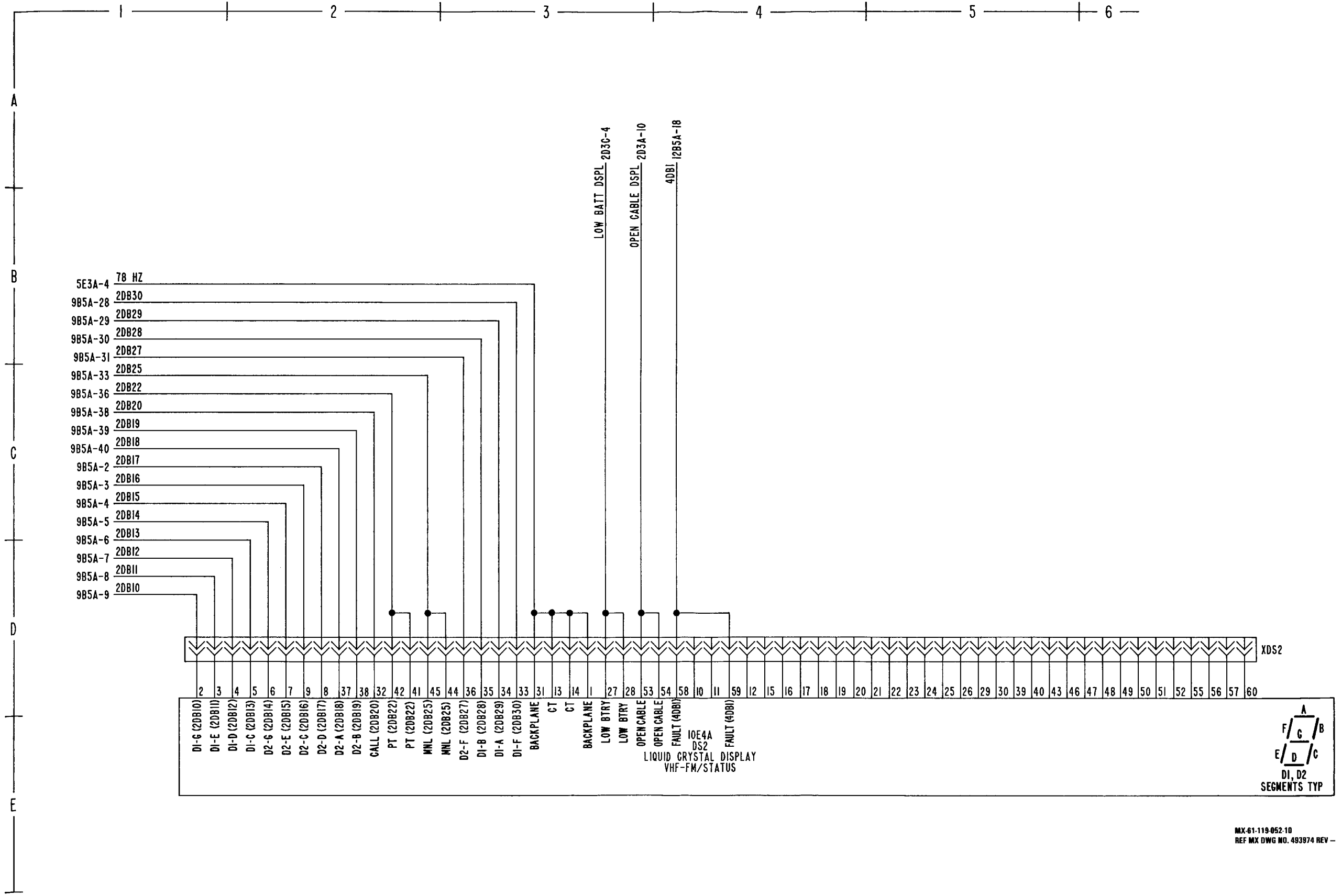

MX-61-119-052-10  
REF MX DWG NO. 483974 REV -

FO-10. RSC Digital Interface Schematic Diagram (Sheet 10 of 12)

FO-127/(FO-128 blank)





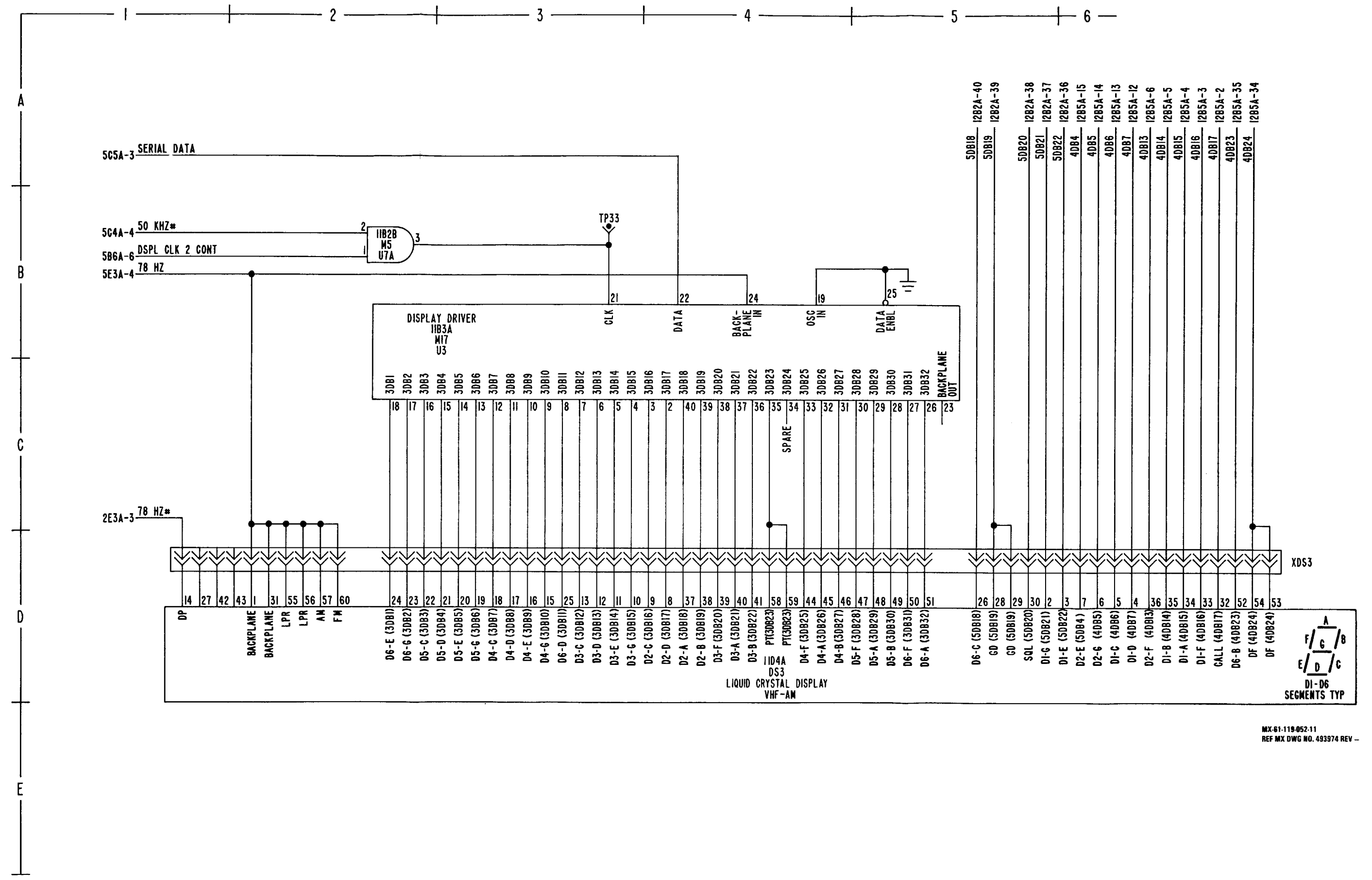

MX-61-119-052-11  
REF MX DWG NO. 493974 REV -

FO-10. RSC Digital Interface Schematic Diagram (Sheet 11 of 12)



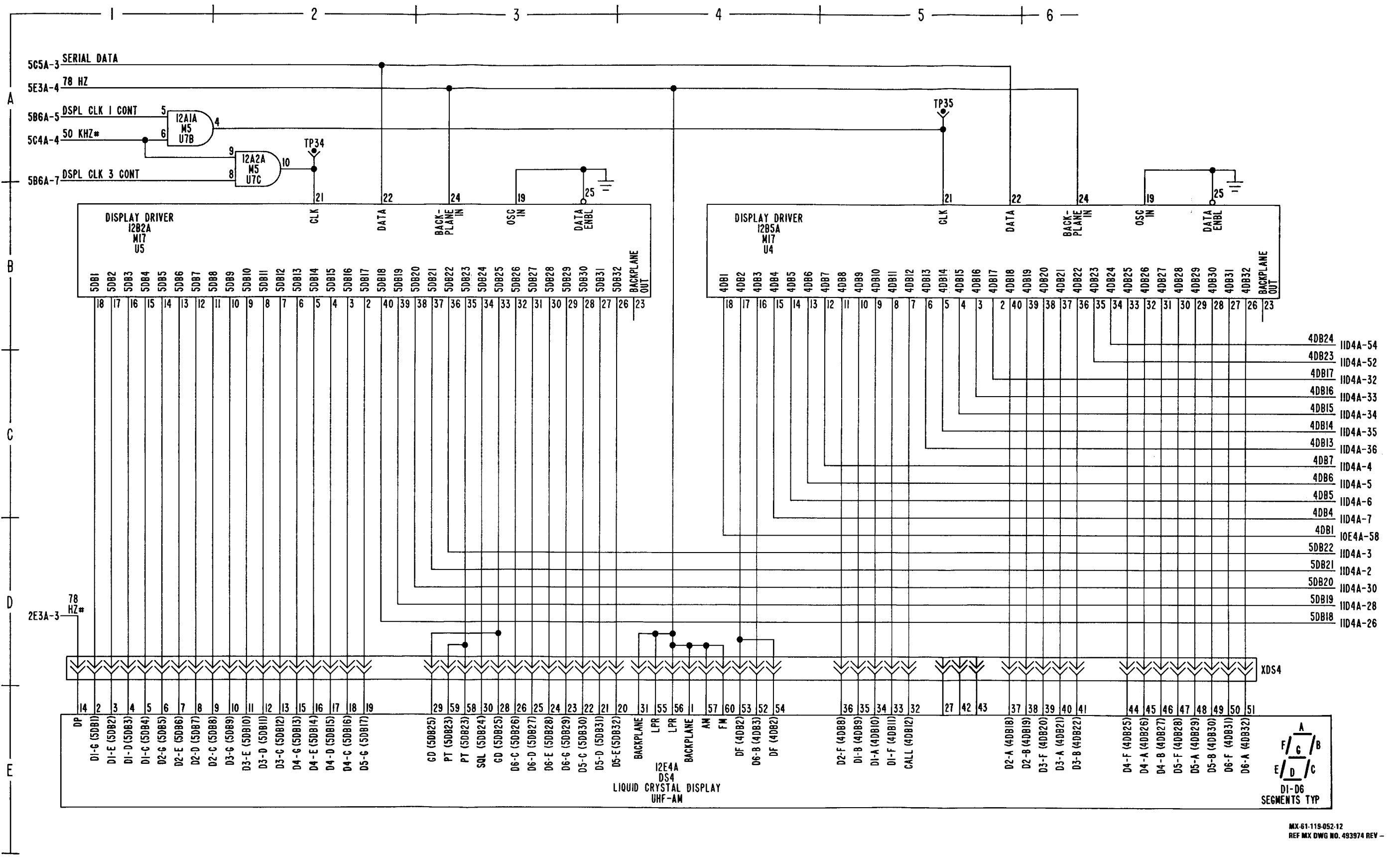

FO-10. RSC Digital Interface Schematic Diagram (Sheet 12 of 12)

MX-61-118-052-12  
REF MX DWG NO. 493974 REV -



**NOTES:**

**1.0 GENERAL:**

- 1.1 INTERPRET DRAWING IN ACCORDANCE WITH STANDARDS PRESCRIBED BY DOD-STD-100.
- 1.2 DATA INCLUDED IN PARENTHESIS, ( ), IS FOR REFERENCE ONLY.
- 1.3 A NUMBER SIGN (#) FOLLOWING A SIGNAL NAME MEANS THE INVERTED (NOT) FORM OF THE SIGNAL.

**2.0 SPECIFIC:**

- 2.1 UNLESS OTHERWISE SPECIFIED:  
RESISTANCE VALUES ARE IN OHMS.  
RESISTORS ARE 5%, 1/8W.  
CAPACITANCE VALUES ARE IN MICROFARADS.  
VOLTAGES ARE DC.  
DIODES AND/OR TRANSISTORS ARE JANTX TYPE.
- 2.2 PARTIAL REFERENCE DESIGNATIONS ARE SHOWN: FOR COMPLETE DESIGNATION PREFIX WITH UNIT NUMBER AND SUBASSEMBLY DESIGNATION SA1A1 & 6A1A1.
- 2.3 FOR CONTINUATION OF CIRCUIT SEE SCHEMATIC 493949.
- 2.4 REFERENCE:  
ASSEMBLY NUMBER 812866-801.  
PRINTED WIRING BOARD 412274-1.

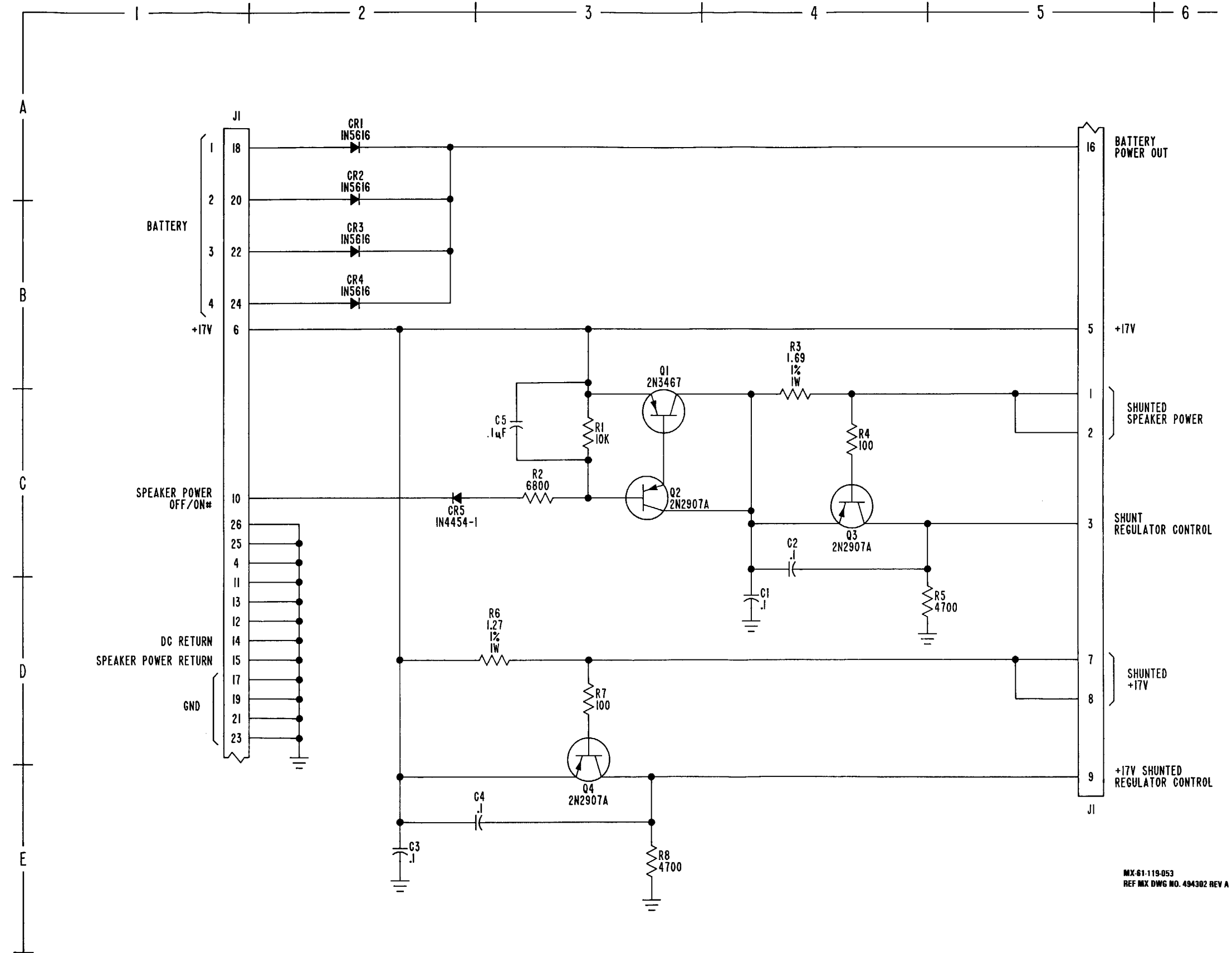

MX-61-119-053  
REF MX DWG NO. 494302 REV A

FO-11. RSC Regulator Schematic Diagram



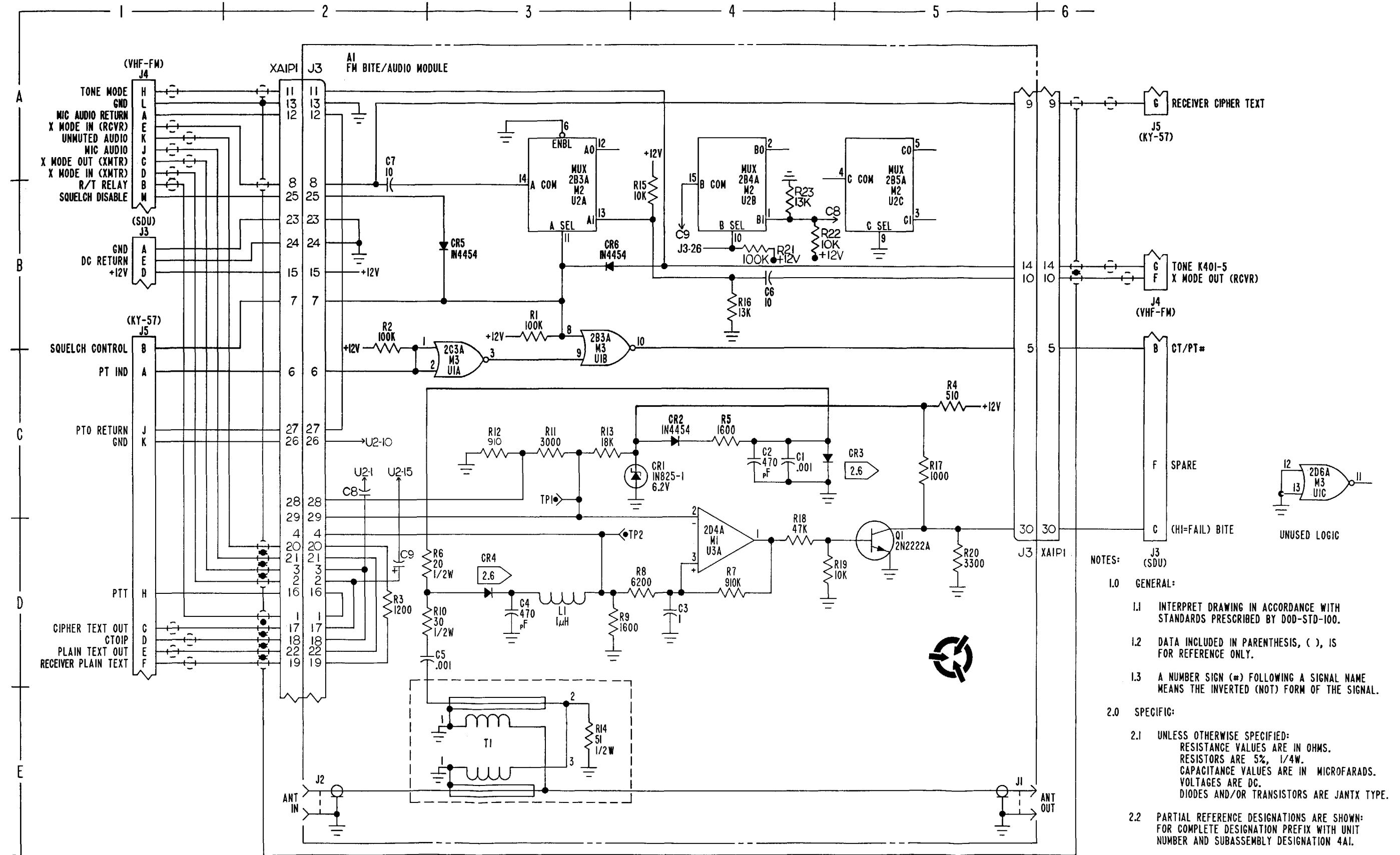

- NOTES:
- J3 (SDU)
- 1.0 GENERAL:
    - 1.1 INTERPRET DRAWING IN ACCORDANCE WITH STANDARDS PRESCRIBED BY DOD-STD-100.
    - 1.2 DATA INCLUDED IN PARENTHESIS, ( ), IS FOR REFERENCE ONLY.
    - 1.3 A NUMBER SIGN (#) FOLLOWING A SIGNAL NAME MEANS THE INVERTED (NOT) FORM OF THE SIGNAL.
  - 2.0 SPECIFIC:
    - 2.1 UNLESS OTHERWISE SPECIFIED: RESISTANCE VALUES ARE IN OHMS. RESISTORS ARE 5%, 1/4W. CAPACITANCE VALUES ARE IN MICROFARADS. VOLTAGES ARE DC. DIODES AND/OR TRANSISTORS ARE JANTX TYPE.
    - 2.2 PARTIAL REFERENCE DESIGNATIONS ARE SHOWN: FOR COMPLETE DESIGNATION PREFIX WITH UNIT NUMBER AND SUBASSEMBLY DESIGNATION 4A1.

MX-61-119-054  
REF MX DWG NO. 494025 REV F

FO-12. FM BITE/Audio Interface Schematic Diagram

FO-135/(FO-136 blank)





NOTES:

GENERAL:

- 1.1 INTERPRET DRAWING IN ACCORDANCE WITH STANDARDS PRESCRIBED BY DOD-STD-100.
- 1.2 DATA INCLUDED IN PARENTHESIS, ( ), IS FOR REFERENCE ONLY.
- 1.3 A NUMBER SIGN (#) FOLLOWING A SIGNAL NAME MEANS THE INVERTED (NOT) FORM OF THE SIGNAL.
- 1.4 CHARACTERS UNDERLINED DENOTE LOWER CASE.

SPECIFIC:

- 2.1 UNLESS OTHERWISE SPECIFIED: VOLTAGES ARE DC.
- 2.2 PARTIAL REFERENCE DESIGNATIONS ARE SHOWN; FOR COMPLETE DESIGNATION PREFIX WITH UNIT NUMBER AND SUBASSEMBLY DESIGNATION 1.
- 2.3 FOR CONTINUATION OF CIRCUIT SEE WIRING DIAGRAM 189916.
- 2.4 REFERENCE: ASSEMBLY NUMBER 812081-801. CASE ASSY 812086-801.

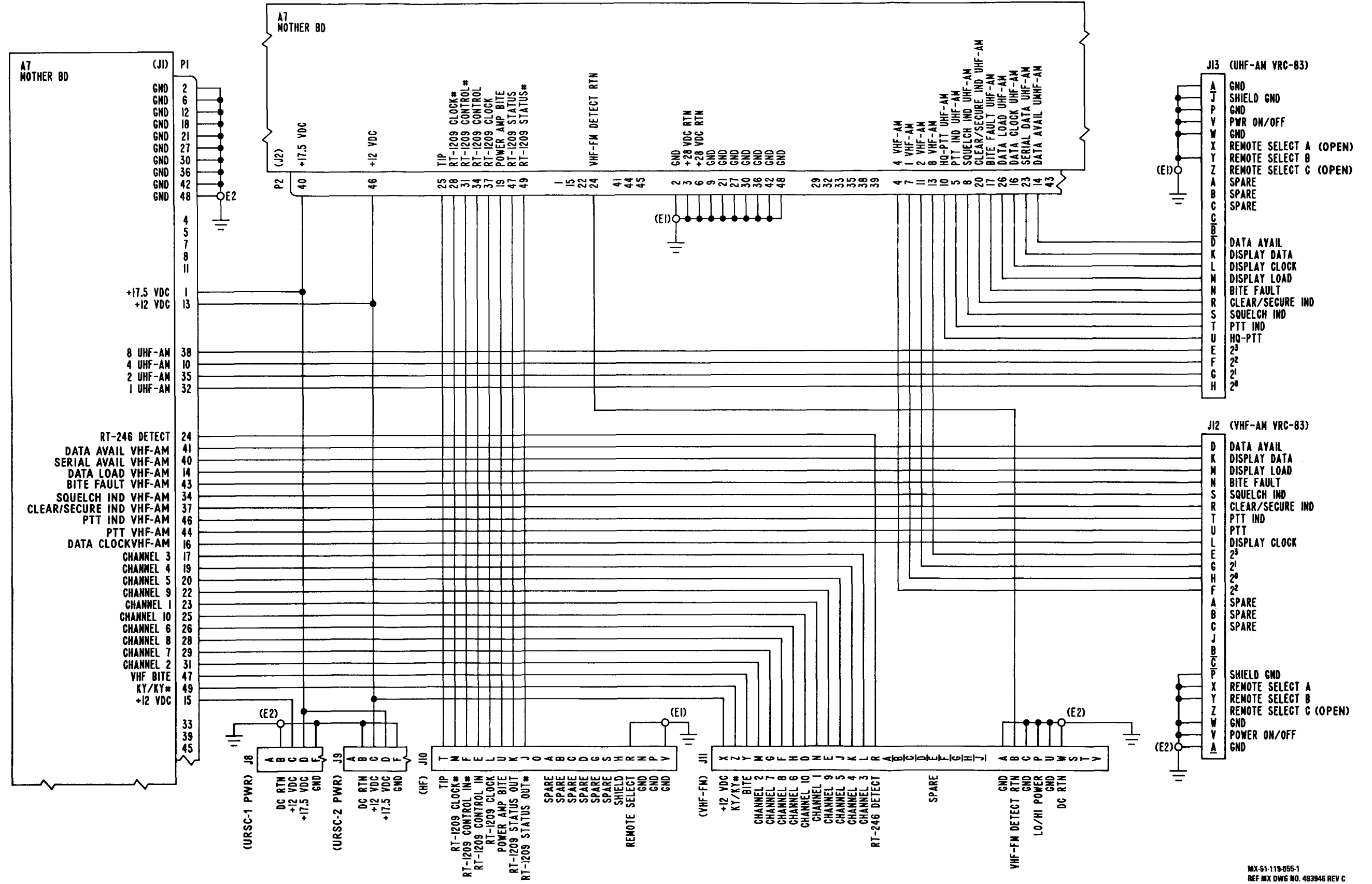

FO-13. Signal Distribution Unit Schematic Diagram (Sheet 1 of 2)



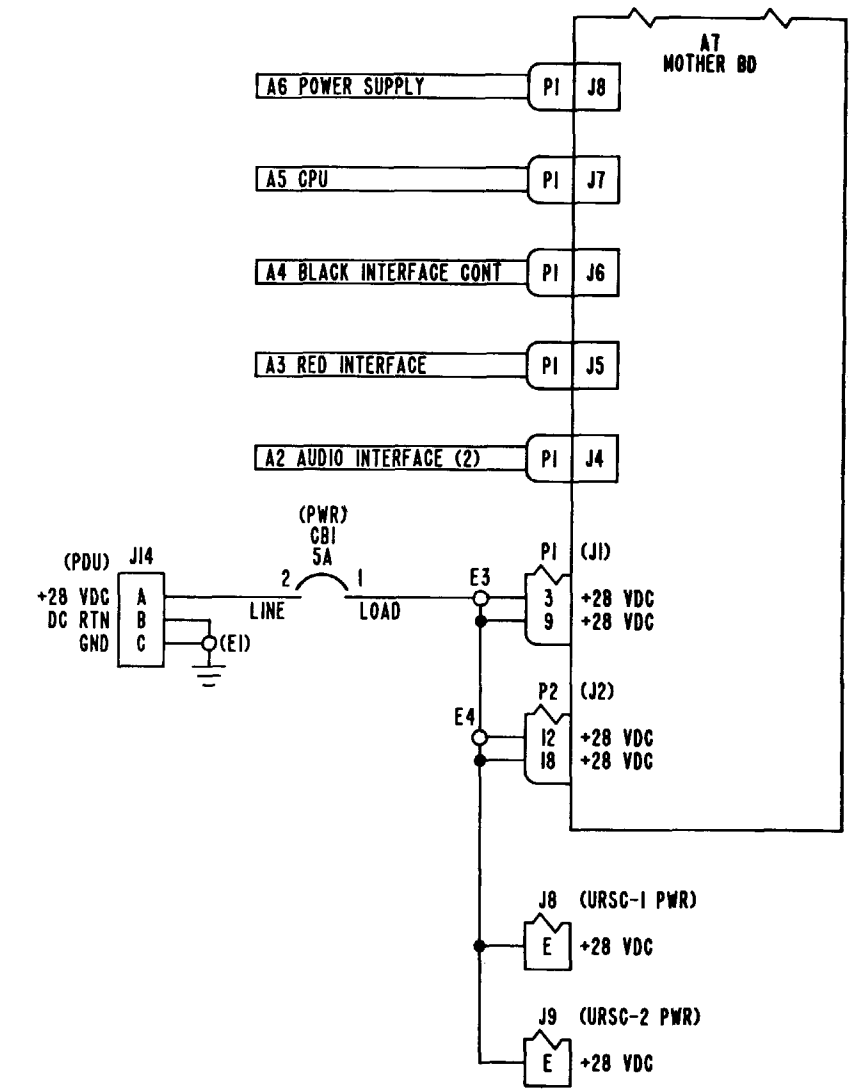
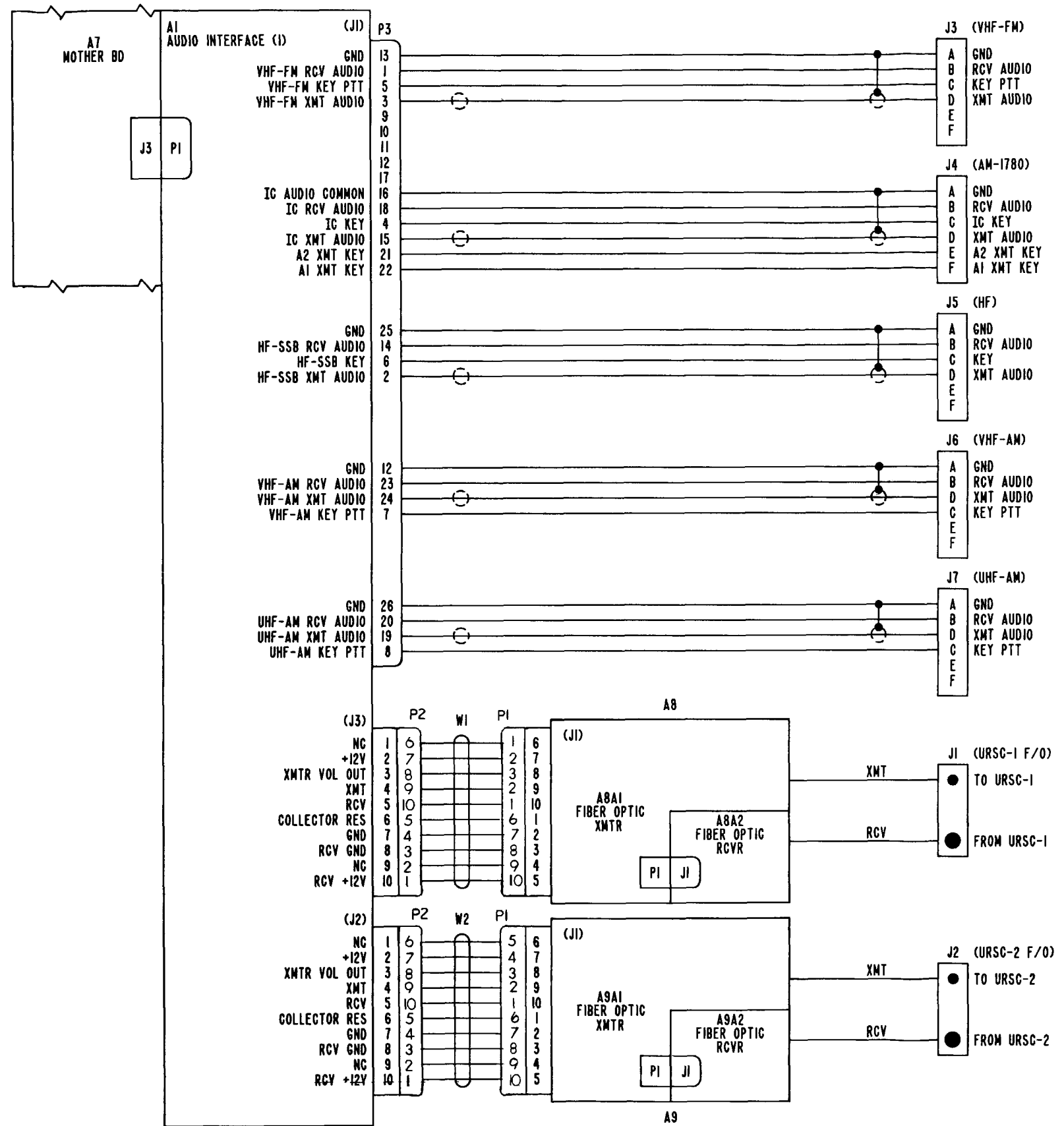

MX-61-119-955-2  
REF MX DWG NO. 493946 REV E

FO-13. Signal Distribution Unit Schematic Diagram (Sheet 2 of 2)



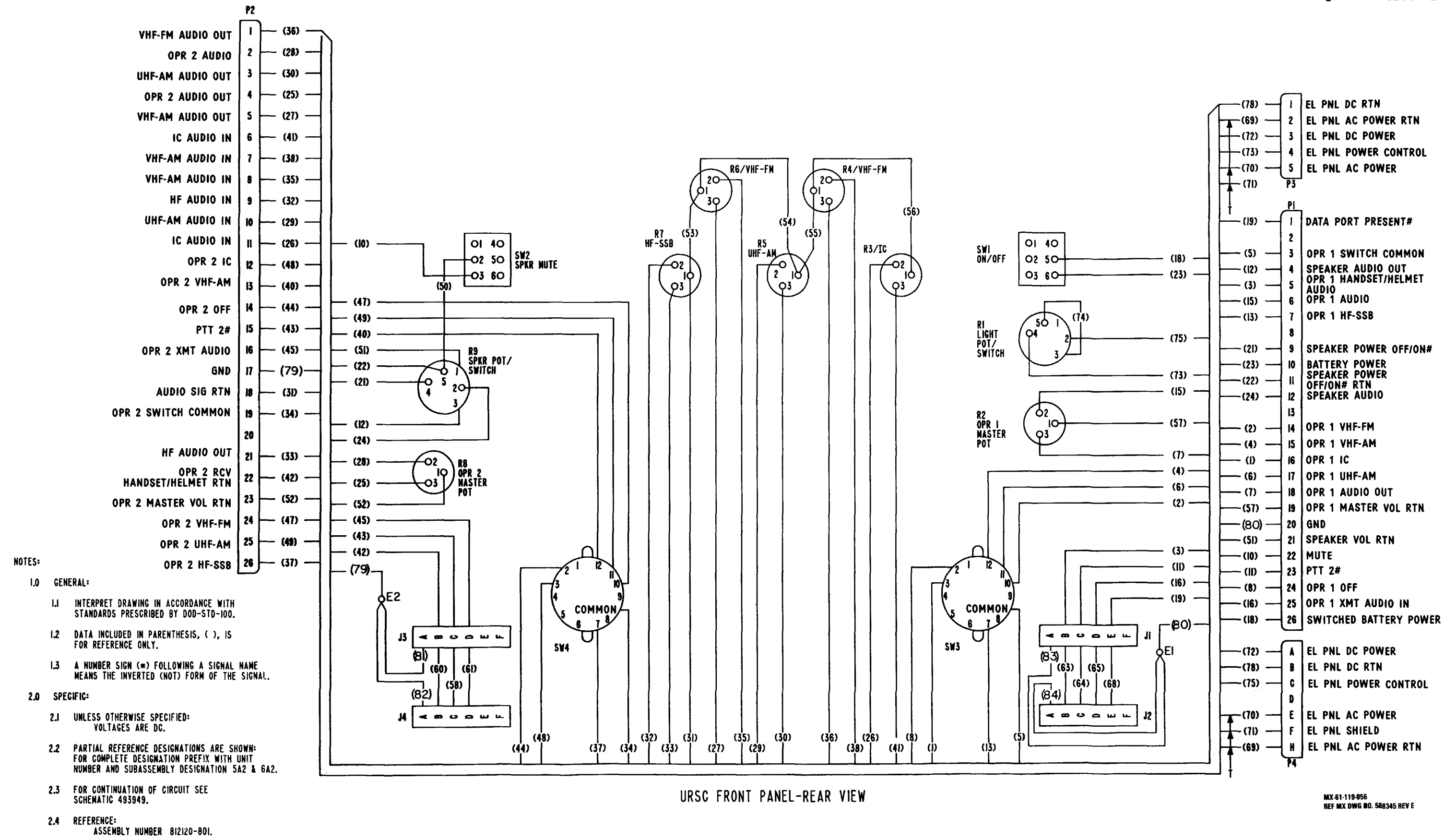

FO-14. RSC Front Panel Wiring Diagram

MX-61-119-956  
REF MX DWG NO. 588345 REV E



- NOTES:
- 1.0 GENERAL:
- 1.1 INTERPRET DRAWING IN ACCORDANCE WITH STANDARDS PRESCRIBED BY DOD-STD-100.
  - 1.2 DATA INCLUDED IN PARENTHESIS, ( ), IS FOR REFERENCE ONLY.
  - 1.3 A NUMBER SIGN (#) FOLLOWING A SIGNAL NAME MEANS THE INVERTED (NOT) FORM OF THE SIGNAL.
- 2.0 SPECIFIC:
- 2.1 UNLESS OTHERWISE SPECIFIED:  
RESISTANCE VALUES ARE IN OHMS.  
RESISTORS ARE 1% 10W.  
CAPACITANCE VALUES ARE IN MICROFARADS.  
VOLTAGES ARE DC.  
DIODES AND/OR TRANSISTORS ARE JANIX TYPE.
  - 2.2 PARTIAL REFERENCE DESIGNATIONS ARE SHOWN. FOR COMPLETE DESIGNATION PREFIX WITH UNIT NUMBER AND SUBASSEMBLY DESIGNATION 5 & 6.
  - 2.3 FOR CONTINUATION OF CIRCUIT SEE WIRING DIAGRAM 789915 & 789916.
  - 2.4 PART NUMBER 616494-901.
  - 2.5 REFERENCE:  
ASSEMBLY NUMBER 812085-801.  
A1 ASSEMBLY NUMBER 812092-801.  
WIRING DIAGRAM 588346.  
WIRE LIST 566615.  
A2 ASSEMBLY NUMBER 812120-801.  
WIRING DIAGRAM 588345.  
WIRE LIST 566614.
  - 2.6 PART NUMBER 814341-801

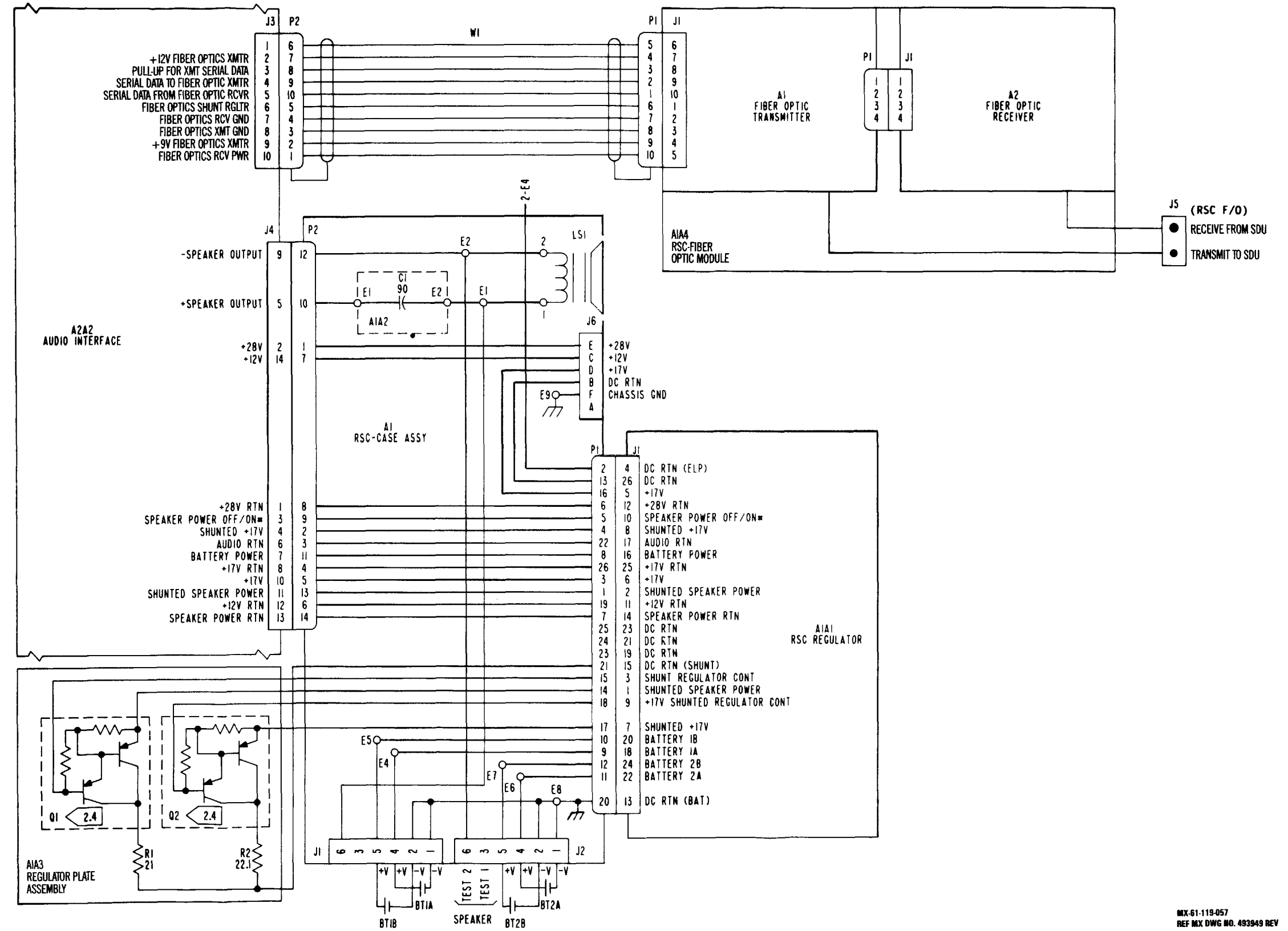





- NOTES:
- 1.0 GENERAL:
    - 1.1 INTERPRET DRAWING IN ACCORDANCE WITH STANDARDS PRESCRIBED BY DOD-STD-100.
    - 1.2 DATA INCLUDED IN PARENTHESIS, ( ), IS FOR REFERENCE ONLY.
    - 1.3 A NUMBER SIGN (#) FOLLOWING A SIGNAL NAME MEANS THE INVERTED (NOT) FORM OF THE SIGNAL.
  - 2.0 SPECIFIC:
    - 2.1 UNLESS OTHERWISE SPECIFIED: VOLTAGES ARE DC.
    - 2.2 PARTIAL REFERENCE DESIGNATIONS ARE SHOWN: FOR COMPLETE DESIGNATION PREFIX WITH UNIT NUMBER AND SUBASSEMBLY DESIGNATION SA2 & 6A2.
    - 2.3 FOR CONTINUATION OF CIRCUIT SEE SCHEMATIC 493949.
    - 2.4 REFERENCE: ASSEMBLY NUMBER 812120-801.

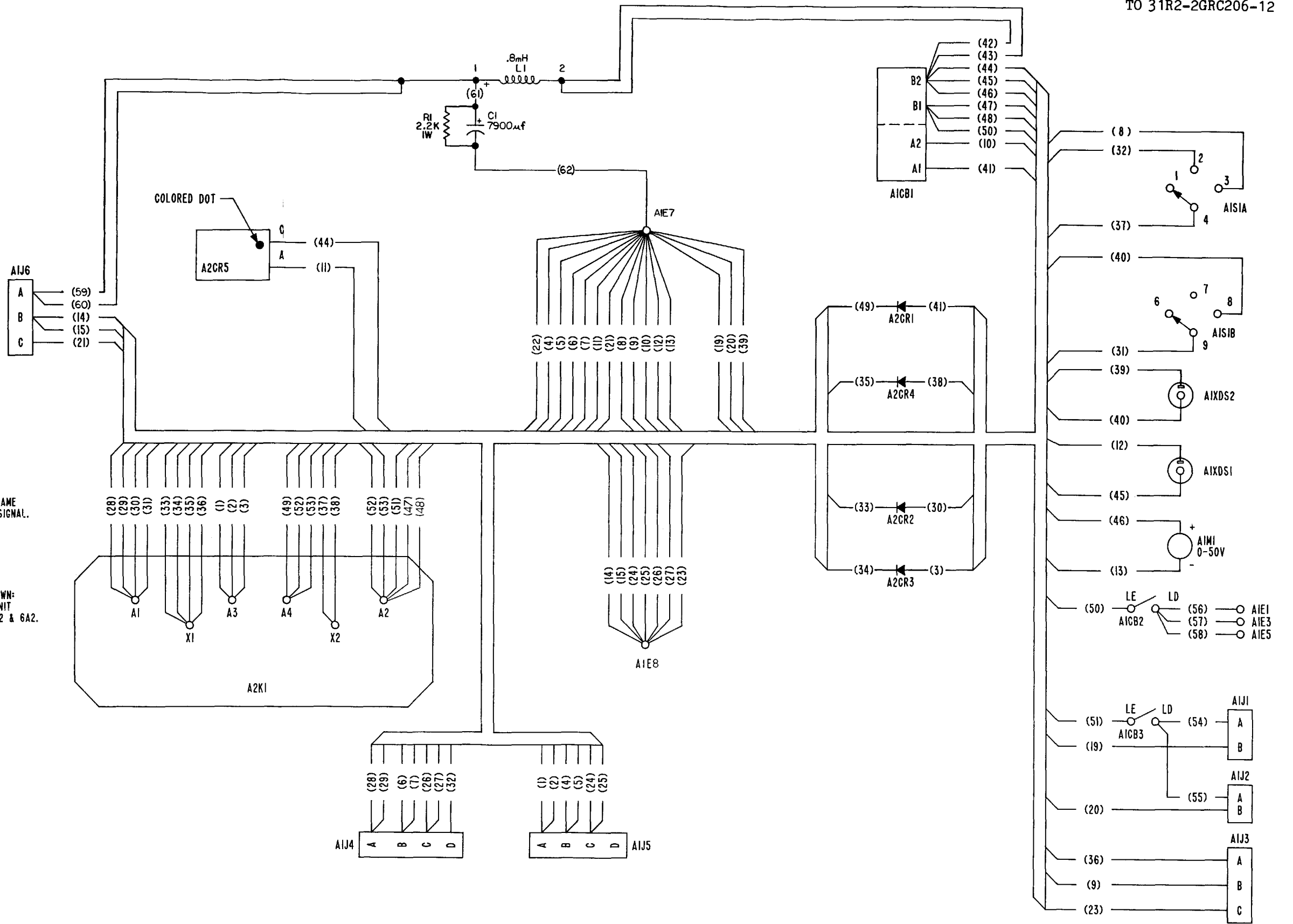

MX-61-119-058  
REF MX DWG NO. 588319 REV B

FO-16. Power Distribution Unit  
Wiring Diagram

FO-145/(FO-146 blank)



| WIRE NO | PART NUMBER    | COLOR   | FROM  | TO    | REMARKS                 |
|---------|----------------|---------|-------|-------|-------------------------|
| 1       | M22759/11-22-6 | BLUE    | P1-1  | J9-D  | +17.5V                  |
| 2       | ▲ /11-24-6     | BLUE    | P1-1  | P2-40 | +17.5V                  |
| 3       | /11-24-0       | BLACK   | P1-2  | P1-6  | GND                     |
| 4       | /11-22-2       | RED     | P1-3  | E3    | +28V                    |
| 5       | /11-18-2       | RED     | E3    | CBI-1 | +28V(FUSED)             |
| 6       | /11-24-0       | BLACK   | P1-6  | P1-12 | GND                     |
| 7       | /11-22-2       | RED     | P1-9  | E3    | +28V                    |
| 8       | /11-22-2       | RED     | E3    | E4    | +28V                    |
| 9       | /11-24-9       | WHITE   | P1-10 | J13-F | 4 UHF-AM                |
| 10      | /11-24-0       | BLACK   | P1-12 | P1-18 | GND                     |
| 11      | /11-24-3       | ORANGE  | P1-13 | J9-C  | +12V                    |
| 12      | /11-24-3       | ORANGE  | P1-13 | P2-46 | +12V                    |
| 13      | /11-24-1       | BROWN   | P1-14 | J12-M | DATA LOAD VHF-AM        |
| 14      | /11-24-93      | WHT-ORN | P1-15 | J8-C  | +12V                    |
| 15      | /11-24-4       | YELLOW  | P1-16 | J12-L | DATA CLOCK VHF-AM       |
| 16      | /11-24-5       | GREEN   | P1-17 | J11-L | CHANNEL 3               |
| 17      | /11-24-0       | BLACK   | P1-18 | P1-21 | GND                     |
| 18      | /11-24-97      | WHT-VIO | P1-19 | J11-K | CHANNEL 4               |
| 19      | /11-24-7       | VIOLET  | P1-20 | J11-J | CHANNEL 5               |
| 20      | /11-24-0       | BLACK   | P1-21 | P1-27 | GND                     |
| 21      | /11-24-8       | GRAY    | P1-22 | J11-E | CHANNEL 9               |
| 22      | /11-24-93      | WHT-BLK | P1-23 | J11-N | CHANNEL 1               |
| 23      | /11-24-91      | WHT-BRN | P1-25 | J11-D | CHANNEL 10              |
| 24      | /11-24-92      | WHT-RED | P1-26 | J11-H | CHANNEL 6               |
| 25      | /11-24-0       | BLACK   | P1-27 | P1-30 | GND                     |
| 26      | /11-24-93      | WHT-ORN | P1-28 | J11-F | CHANNEL 8               |
| 27      | /11-24-94      | WHT-YEL | P1-29 | J11-G | CHANNEL 7               |
| 28      | /11-24-0       | BLACK   | P1-30 | P1-36 | GND                     |
| 29      | /11-24-95      | WHT-GRN | P1-31 | J11-M | CHANNEL 2               |
| 30      | /11-24-96      | WHT-BLU | P1-32 | J13-H | 1 UHF-AM                |
| 31      | /11-24-98      | WHT-GRA | P1-34 | J12-S | SQUELCH IND VHF-AM      |
| 32      | /11-24-6       | BLUE    | P1-35 | J13-G | 2 UHF-AM                |
| 33      | /11-24-0       | BLACK   | P1-36 | P1-42 | GND                     |
| 34      | /11-24-5       | GREEN   | P1-37 | J12-R | CLEAR/SECURE IND VHF-AM |
| 35      | /11-24-8       | GRAY    | P1-38 | J13-E | 8 UHF-AM                |
| 36      | /11-24-91      | WHT-BRN | P1-40 | J12-K | SERIAL DATA VHF-AM      |
| 37      | /11-24-7       | VIOLET  | P1-41 | J12-D | DATA AVAIL VHF-AM       |
| 38      | /11-24-0       | BLACK   | P1-42 | P1-48 | GND                     |
| 39      | /11-24-92      | WHT-RED | P1-43 | J12-N | BITE FAULT VHF-AM       |
| 40      | /11-24-97      | WHT-VIO | P1-44 | J12-U | PTT VHF-AM              |
| 41      | /11-24-93      | WHT-ORN | P1-46 | J12-T | PTT IND VHF-AM          |
| 42      | /11-24-9       | WHITE   | P1-47 | J11-Y | VHF BITE                |
| 43      | /11-22-0       | BLACK   | P1-48 | E2    | GND                     |
| 44      | /11-24-1       | BROWN   | P1-49 | J11-Z | KY/KY#                  |
| 45      | /11-22-0       | BLACK   | P2-2  | P2-3  | GND                     |
| 46      | /11-22-0       | BLACK   | P2-2  | E1    | GND                     |
| 47      | /11-24-0       | BLACK   | P2-3  | P2-6  | +28V RTN                |
| 48      | /11-24-9       | WHITE   | P2-4  | J12-F | 4 VHF-AM                |
| 49      | /11-24-1       | BROWN   | P2-5  | J13-T | PTT IND UHF-AM          |
| 50      | /11-24-0       | BLACK   | P2-6  | P2-9  | +28V RTN                |
| 51      | /11-24-6       | BLUE    | P2-7  | J12-H | 1 VHF-AM                |
| 52      | /11-24-5       | GREEN   | P2-8  | J13-S | SQUELCH IND UHF-AM      |
| 53      | /11-24-0       | BLACK   | P2-9  | P2-21 | GND                     |
| 54      | /11-24-7       | VIOLET  | P2-10 | J13-U | HQ-PTT UHF-AM           |
| 55      | /11-24-8       | GRAY    | P2-11 | J12-G | 2 VHF-AM                |
| 56      | /11-22-2       | RED     | P2-12 | E4    | +28V                    |
| 57      | /11-24-90      | WHT-BLK | P2-13 | J12-E | 8 VHF-AM                |
| 58      | /11-24-91      | WHT-BRN | P2-14 | J13-D | DATA AVAIL UHF-AM       |
| 59      | /11-24-93      | WHT-RED | P2-16 | J13-L | DATA CLOCK UHF-AM       |
| 60      | /11-24-92      | WHT-ORN | P2-17 | J13-N | BITE FAULT UHF-AM       |
| 61      | /11-22-2       | RED     | P2-18 | E4    | +28V                    |
| 62      | /11-24-1       | BROWN   | P2-19 | J10-U | POWER AMP BITE          |
| 63      | /11-24-95      | WHT-GRN | P2-20 | J13-R | CLEAR/SECURE IND UHF-AM |
| 64      | /11-24-0       | BLACK   | P2-21 | P2-27 | GND                     |
| 65      | /11-24-97      | WHT-VIO | P2-23 | J13-K | SERIAL DATA UHF-AM      |
| 66      | /11-24-96      | WHT-BLU | P2-25 | J10-T | TIP                     |
| 67      | /11-24-98      | WHT-GRA | P2-26 | J13-M | DATA LOAD UHF-AM        |
| 68      | /11-24-0       | BLACK   | P2-27 | P2-30 | GND                     |
| 69      | ▼ /11-24-4     | YELLOW  | P2-28 | J10-M | RT-1209 CLOCK#          |
| 70      | M22759/11-24-0 | BLACK   | P2-30 | P2-36 | GND                     |

| WIRE NO | PART NUMBER     | COLOR      | FROM  | TO         | REMARKS           |
|---------|-----------------|------------|-------|------------|-------------------|
| 71      | M22759/11-24-5  | GREEN      | P2-31 | J10-F      | RT-1209 CONTROL#  |
| 72      | ▲ /11-24-7      | VIOLET     | P2-34 | J10-E      | RT-1209 CONTROL   |
| 73      | /11-24-0        | BLACK      | P2-36 | P2-42      | GND               |
| 74      | /11-24-8        | GRAY       | P2-37 | J10-L      | RT-1209 CLOCK     |
| 75      | /11-22-6        | BLUE       | P2-40 | J8-D       | +17.5V            |
| 76      | /11-24-0        | BLACK      | P2-42 | P2-48      | GND               |
| 77      |                 |            |       |            |                   |
| 78      | /11-24-3        | ORANGE     | P2-46 | J11-X      | +12V              |
| 79      | /11-24-9        | WHITE      | P2-47 | J10-K      | RT-1209 STATUS    |
| 80      | ▼ /11-24-93     | WHT-ORN    | P2-49 | J10-J      | RT-1209 STATUS#   |
| 81      | M22759/11-24-1  | BROWN      | P3-18 | J4-B       | IC RCV AUDIO      |
| 82      | 469557-242      | WHT (SHLD) | P3-15 | J4-D       | IC XMT AUDIO      |
| 83      | 469557-243      | ORN (SHLD) | P3-2  | J5-D       | HF-SSB XMT AUDIO  |
| 84      | M22759/11-24-0  | BLACK      | P3-16 | J4-A       | IC AUDIO COMMON   |
| 85      | 469557-244      | YEL (SHLD) | P3-3  | J3-D       | VHF-FM XMT AUDIO  |
| 86      | M22759/11-24-5  | GREEN      | P3-14 | J5-B       | HF-SSB RCV AUDIO  |
| 87      | ▲ /11-24-6      | BLUE       | P3-4  | J4-C       | IC KEY            |
| 88      | ▲ /11-24-5      | VIOLET     | P3-1  | J3-B       | VHF-FM RCV AUDIO  |
| 89      | /11-24-8        | GRAY       | P3-5  | J3-C       | VHF-FM KEY PTT    |
| 90      | /11-24-9        | WHITE      | P3-6  | J5-C       | HF-SSB KEY        |
| 91      | /11-24-2        | RED        | P3-7  | J6-C       | VHF-AM KEY PTT    |
| 92      | /11-24-3        | ORANGE     | P3-21 | J4-E       | A2 XMT KEY        |
| 93      | ▼ /11-24-4      | YELLOW     | P3-8  | J7-C       | UHF-AM KEY PTT    |
| 94      | M22759/11-24-90 | WHT-BLK    | P3-22 | J4-F       | A1 XMT KEY        |
| 95      | 469557-245      | GRN (SHLD) | P3-19 | J7-D       | UHF-AM XMT AUDIO  |
| 96      | M22759/11-24-0  | BLACK      | P3-26 | J7-A       | GND               |
| 97      | ▲ /11-24-91     | WHT-BRN    | P3-20 | J7-B       | UHF-AM RCV AUDIO  |
| 98      | ▼ /11-24-0      | BLACK      | P3-13 | J3-A       | GND               |
| 99      | M22759/11-24-0  | BLACK      | P3-25 | J5-A       | GND               |
| 100     | 469557-241      | BRN (SHLD) | P3-24 | J6-D       | VHF-AM XMT AUDIO  |
| 101     | M22759/11-24-0  | BLACK      | P3-12 | J6-A       | GND               |
| 102     | ▲ /11-24-92     | WHT-RED    | P3-23 | J6-B       | VHF-AM RCV AUDIO  |
| 103     | ▲ /11-24-0      | BLACK      | J3-A  | W85 (SHLD) | GND               |
| 104     | /11-24-0        | BLACK      | J4-A  | W82 (SHLD) | GND               |
| 105     | /11-24-0        | BLACK      | J5-A  | W83 (SHLD) | GND               |
| 106     | /11-24-0        | BLACK      | J6-A  | 100 (SHLD) | GND               |
| 107     | /11-24-0        | BLACK      | J7-A  | 95 (SHLD)  | GND               |
| 108     | /11-24-0        | BLACK      | E1    | J13-P      | GND               |
| 109     | /11-24-0        | BLACK      | E1    | J13-V      | GND               |
| 110     | /11-24-0        | BLACK      | E1    | J13-W      | GND               |
| 111     | /11-24-0        | BLACK      | E1    | J13-Y      | GND               |
| 112     | /11-24-0        | BLACK      | E1    | J13-A      | GND               |
| 113     | ▼ /11-22-0      | BLACK      | E1    | J14-C      | GND               |
| 114     | M22759/11-22-0  | BLACK      | E1    | J14-B      | GND               |
| 115     |                 |            |       |            |                   |
| 116     |                 |            |       |            |                   |
| 117     |                 |            |       |            |                   |
| 118     | M22759/11-24-0  | BLACK      | E1    | J10-R      | GND               |
| 119     | ▲ /11-24-0      | BLACK      | E1    | J10-V      | GND               |
| 120     | /11-24-C        | BLACK      | E2    | J8-B       | GND               |
| 121     | /11-24-0        | BLACK      | E2    | J9-B       | GND               |
| 122     | /11-24-0        | BLACK      | E2    | J11-A      | GND               |
| 123     | /11-24-0        | BLACK      | E2    | J11-U      | GND               |
| 124     | /11-24-0        | BLACK      | E2    | J11-W      | GND               |
| 125     | /11-24-0        | BLACK      | E2    | J12-P      | GND               |
| 126     | /11-24-0        | BLACK      | E2    | J12-V      | GND               |
| 127     | /11-24-0        | BLACK      | E2    | J12-W      | GND               |
| 128     | /11-24-0        | BLACK      | E2    | J12-X      | GND               |
| 129     | /11-24-0        | BLACK      | E2    | J12-Y      | GND               |
| 130     | /11-24-0        | BLACK      | E2    | J12-A      | GND               |
| 131     | /11-24-0        | BLACK      | E2    | J11-P      | GND               |
| 132     | /11-18-2        | RED        | J14-A | CBI-2      | +28V(FUSED)       |
| 133     | /11-24-0        | BLACK      | E1    | J13-J      | SHIELD GND        |
| 134     | /11-24-0        | BLACK      | E2    | J11-C      | GND               |
| 135     | /11-24-98       | WHT-GRA    | P1-24 | J11-R      | RT-246 DETECT     |
| 136     | /11-22-2        | RED        | E4    | J8-E       | +28V              |
| 137     | /11-22-2        | RED        | E4    | J9-E       | +28V              |
| 138     | /11-24-2        | RED        | P2-24 | J11-B      | VHF-FM DETECT RTN |
| 139     | ▼ /11-22-0      | BLACK      | J8-F  | E2         | GND               |
| 140     | M22759/11-22-0  | BLACK      | J9-F  | E2         | GND               |

NOTES:

- 1.0 GENERAL:
  - 1.1 INTERPRET DRAWING IN ACCORDANCE WITH STANDARDS PRESCRIBED BY DOD-STD-100.
  - 1.2 DATA INCLUDED IN PARENTHESIS, ( ), IS FOR REFERENCE ONLY.
  - 1.3 A NUMBER SIGN (#) FOLLOWING A SIGNAL NAME MEANS THE INVERTED (NOT) FORM OF THE SIGNAL.
  - 1.4 CHARACTERS UNDERLINED DENOTE LOWER CASE.
- 2.0 SPECIFIC:
  - 2.1 UNLESS OTHERWISE SPECIFIED: VOLTAGES ARE DC.
  - 2.2 PARTIAL REFERENCE DESIGNATIONS ARE SHOWN FOR COMPLETE DESIGNATION PREFIX WITH UNIT NUMBER AND SUBASSEMBLY DESIGNATION I.
  - 2.3 REFERENCE: ASSEMBLY NUMBER 812081-801.



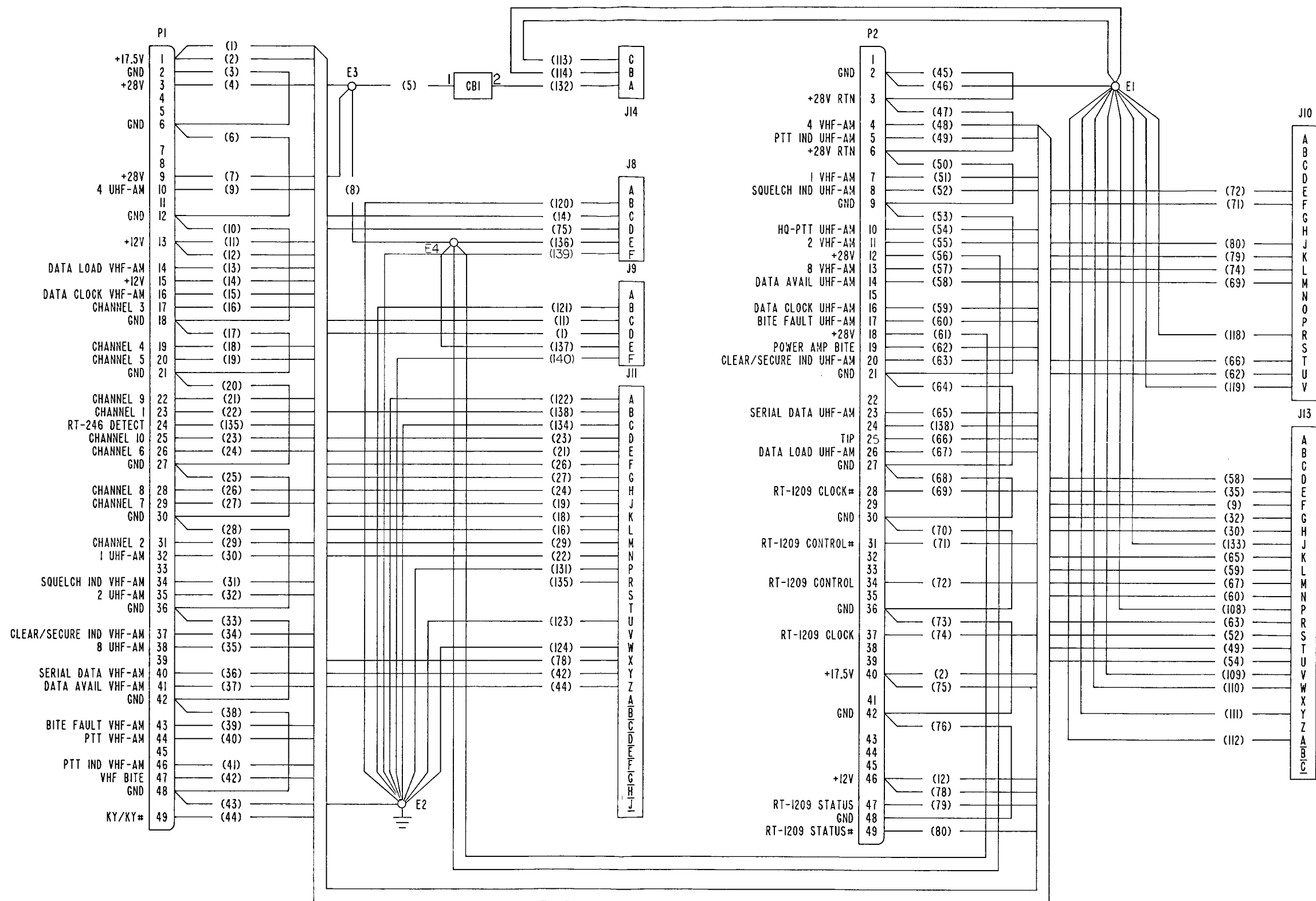

TO SH 3

MX-61-118-000-2  
REF MX DWG NO. 588443 REV D

FO-17. Signal Distribution Unit  
Wiring Diagram (Sheet 2 of 3)



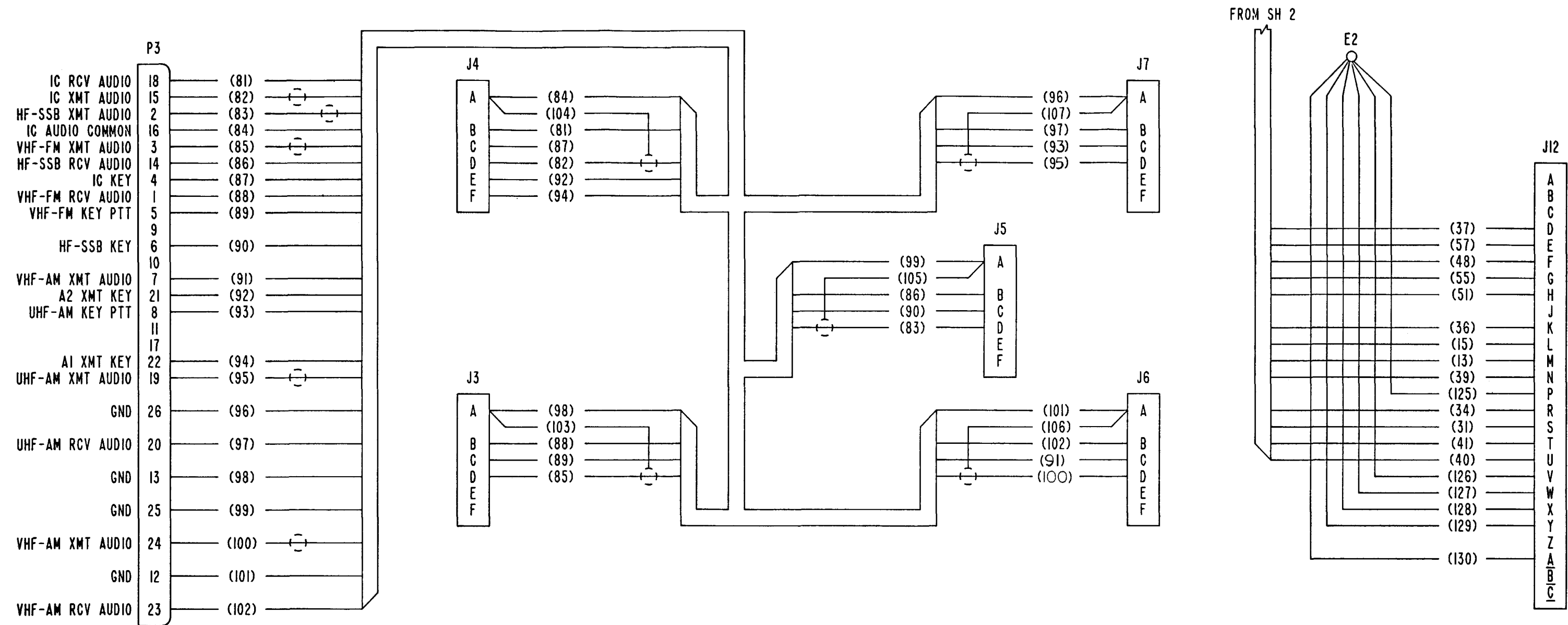

MX-61-118-900-3  
REF MX DWG NO. 588443 REV A

FO-17. Signal Distribution Unit  
Wiring Diagram (Sheet 3 of 3)





NOTES:

- 1.0 GENERAL:
  - 1.1 INTERPRET DRAWING IN ACCORDANCE WITH STANDARDS PRESCRIBED BY DOD-STD-100.
  - 1.2 DATA INCLUDED IN PARENTHESIS, ( ), IS FOR REFERENCE ONLY.
  - 1.3 A NUMBER SIGN (#) FOLLOWING A SIGNAL NAME MEANS THE INVERTED (NOT) FORM OF THE SIGNAL.
- 2.0 SPECIFIC:
  - 2.1 UNLESS OTHERWISE SPECIFIED:
    - RESISTANCE VALUES ARE IN OHMS.
    - RESISTORS ARE 5%, 1/8W.
    - CAPACITANCE VALUES ARE IN MICROFARADS.
    - VOLTAGES ARE DC.
    - DIODES AND/OR TRANSISTORS ARE JANTX TYPE.
  - 2.2 PARTIAL REFERENCE DESIGNATIONS ARE SHOWN: FOR COMPLETE DESIGNATION PREFIX WITH UNIT NUMBER AND SUBASSEMBLY DESIGNATION 3A2A1.
  - 2.3 FOR CONTINUATION OF CIRCUIT SEE SCHEMATIC 493977.
  - 2.4  THIS DEVICE REQUIRES SPECIAL HANDLING AND PROCESSING TO PREVENT DAMAGE FROM ELECTROSTATIC DISCHARGE TRANSIENTS.
  - 2.5 REFERENCE:
    - ASSEMBLY NUMBER 812136-801.
    - PRINTED WIRING BOARD 412047-1.

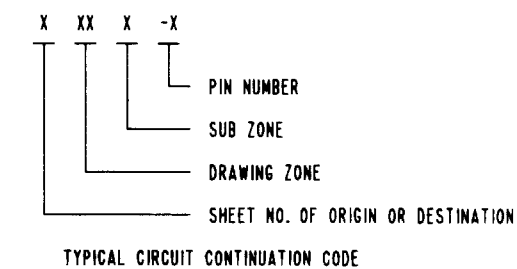

MX-61-119-064-1  
REF MX DWG 493979 REV D

FO-18. Panel Interface Schematic  
Diagram (Sheet 1 of 5)

FO-153/(FO-154 blank)



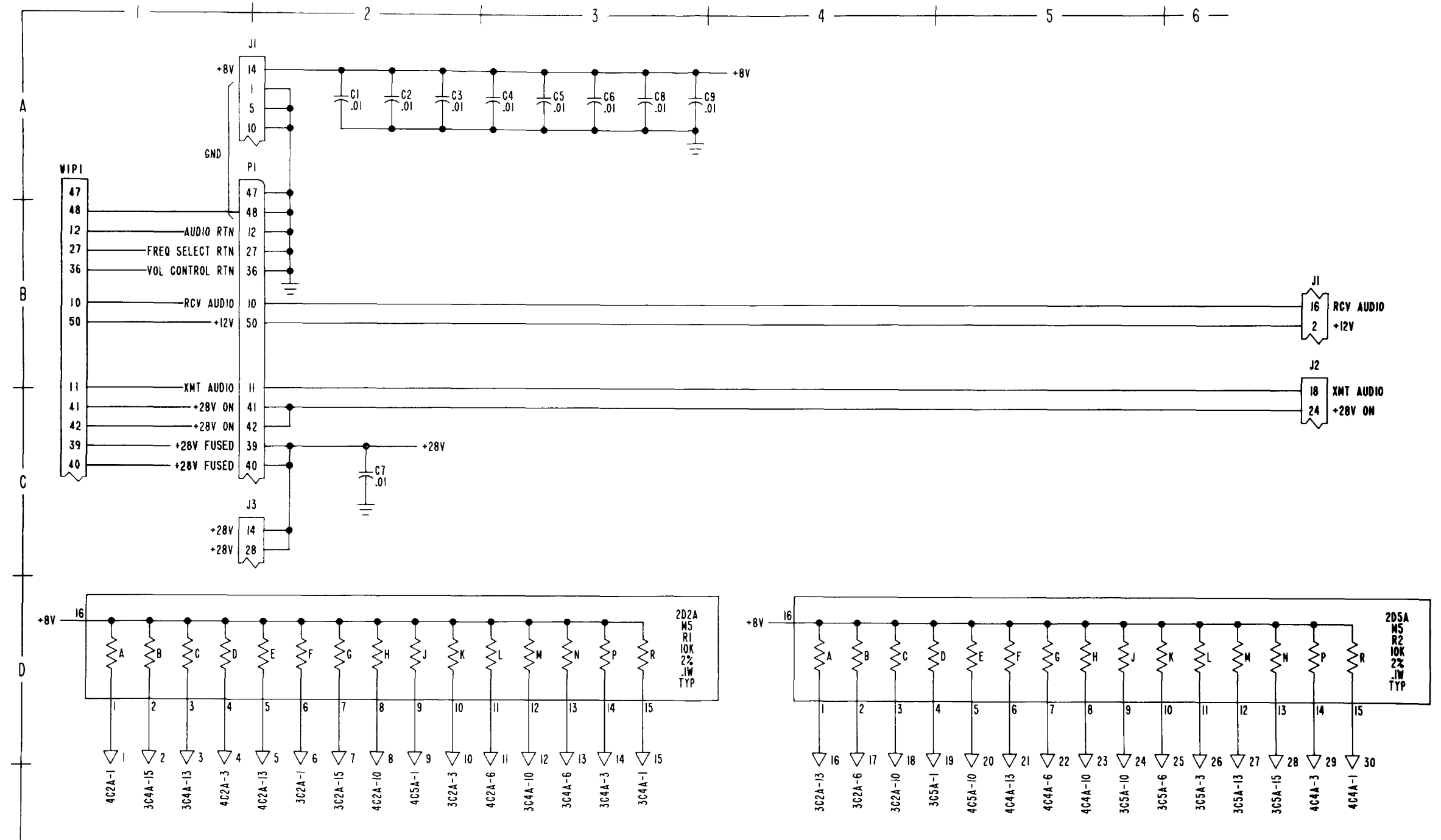

MX-61-119-064-2  
REF MX DWG 493979 REV A

FO-18. Panel Interface Schematic  
Diagram (Sheet 2 of 5)

FO-155/(FO-156 blank)



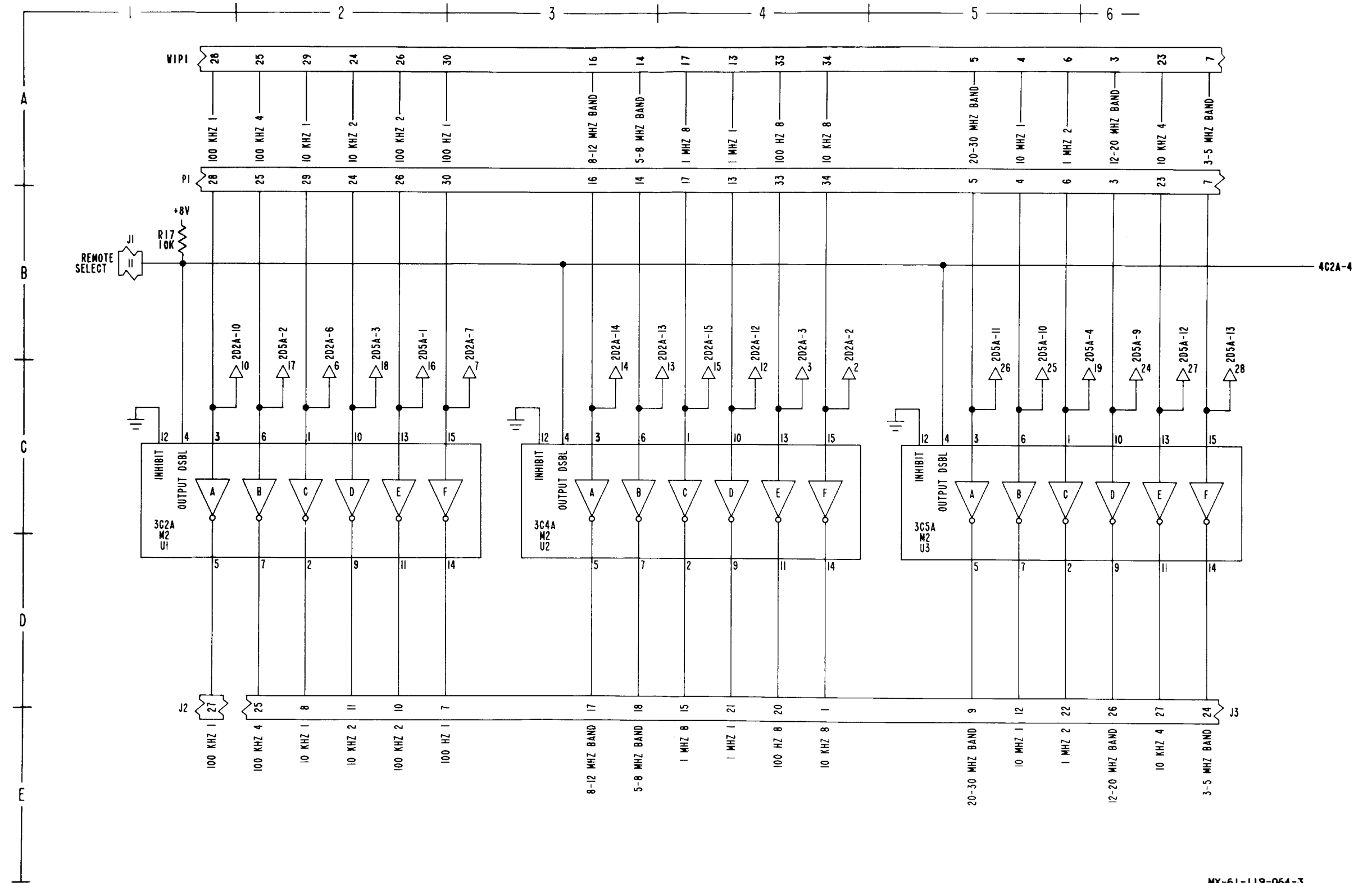

MX-61-119-064-3  
REF MX DMG 493979 REV C

FO-18. Panel Interface Schematic Diagram (Sheet 3 of 5)

FO-157/(FO-158 blank)



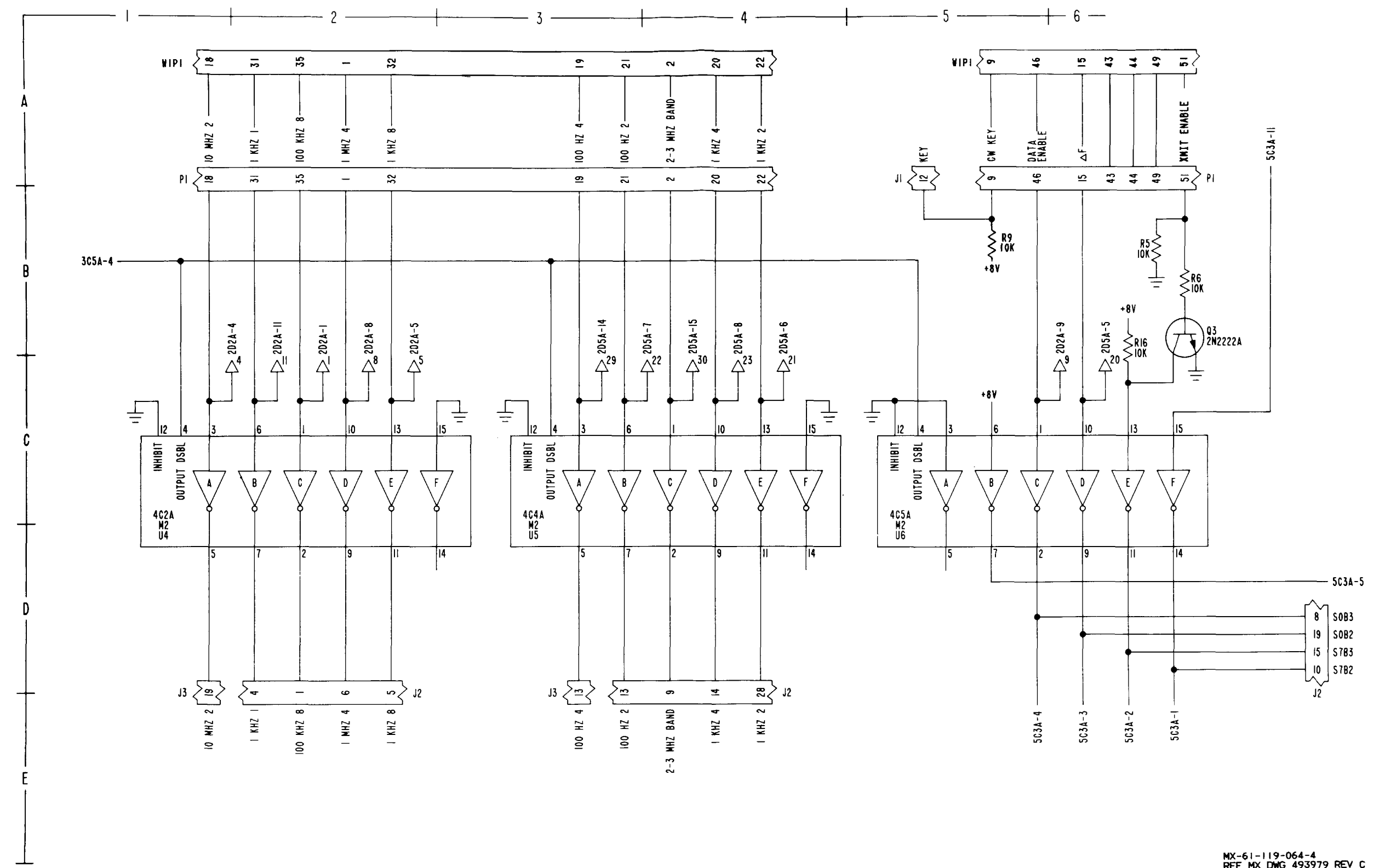

MX-61-119-064-4  
REF MX DWG 493979 REV C

FO-18. Panel Interface Schematic Diagram (Sheet 4 of 5)

FO-159/(FO-160 blank)





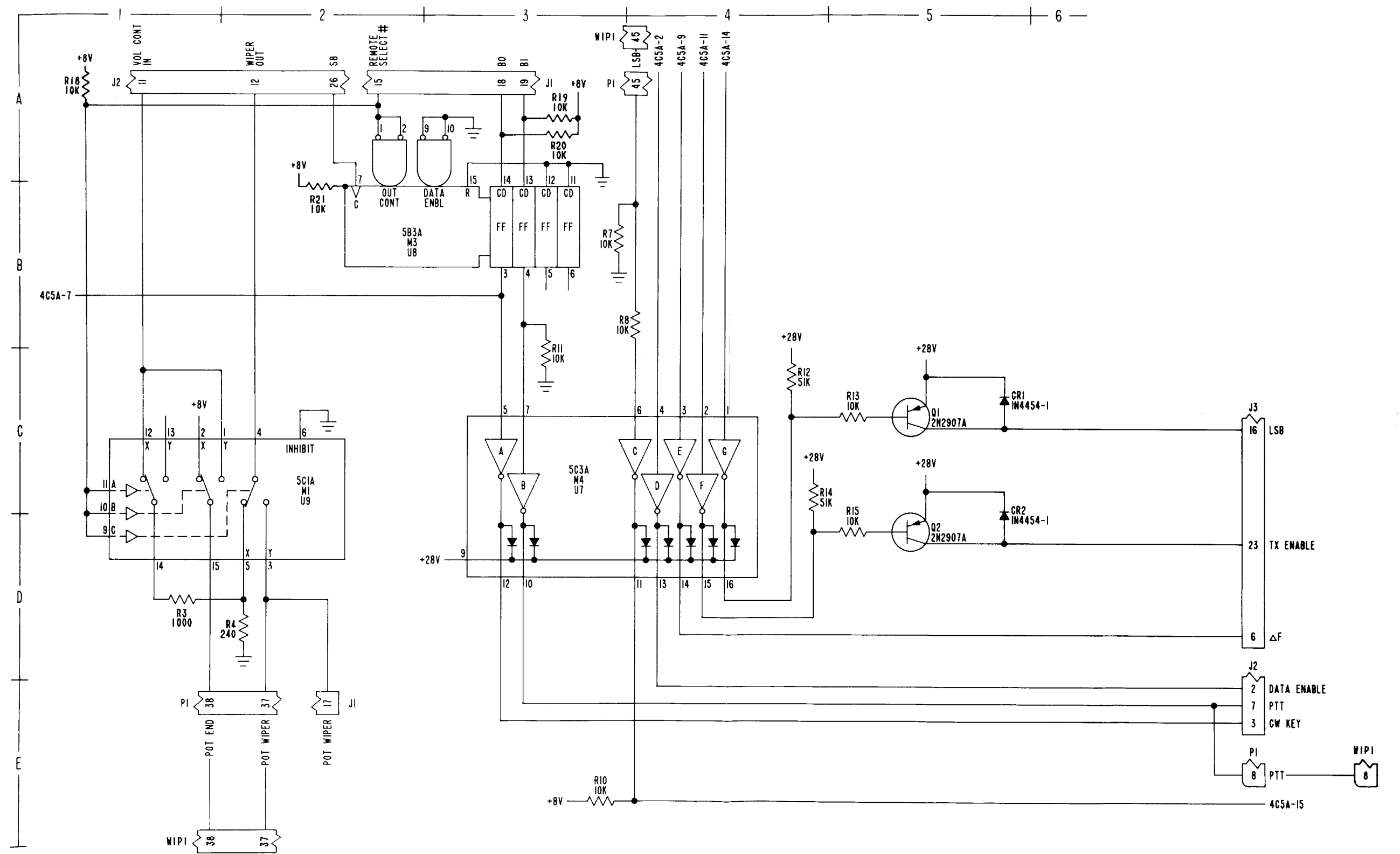

MX-61-119-064-5  
REF MX DWG 493979 REV C

FO-18. Panel Interface Schematic Diagram (Sheet 5 of 5)

FO-161/(FO-162 blank)



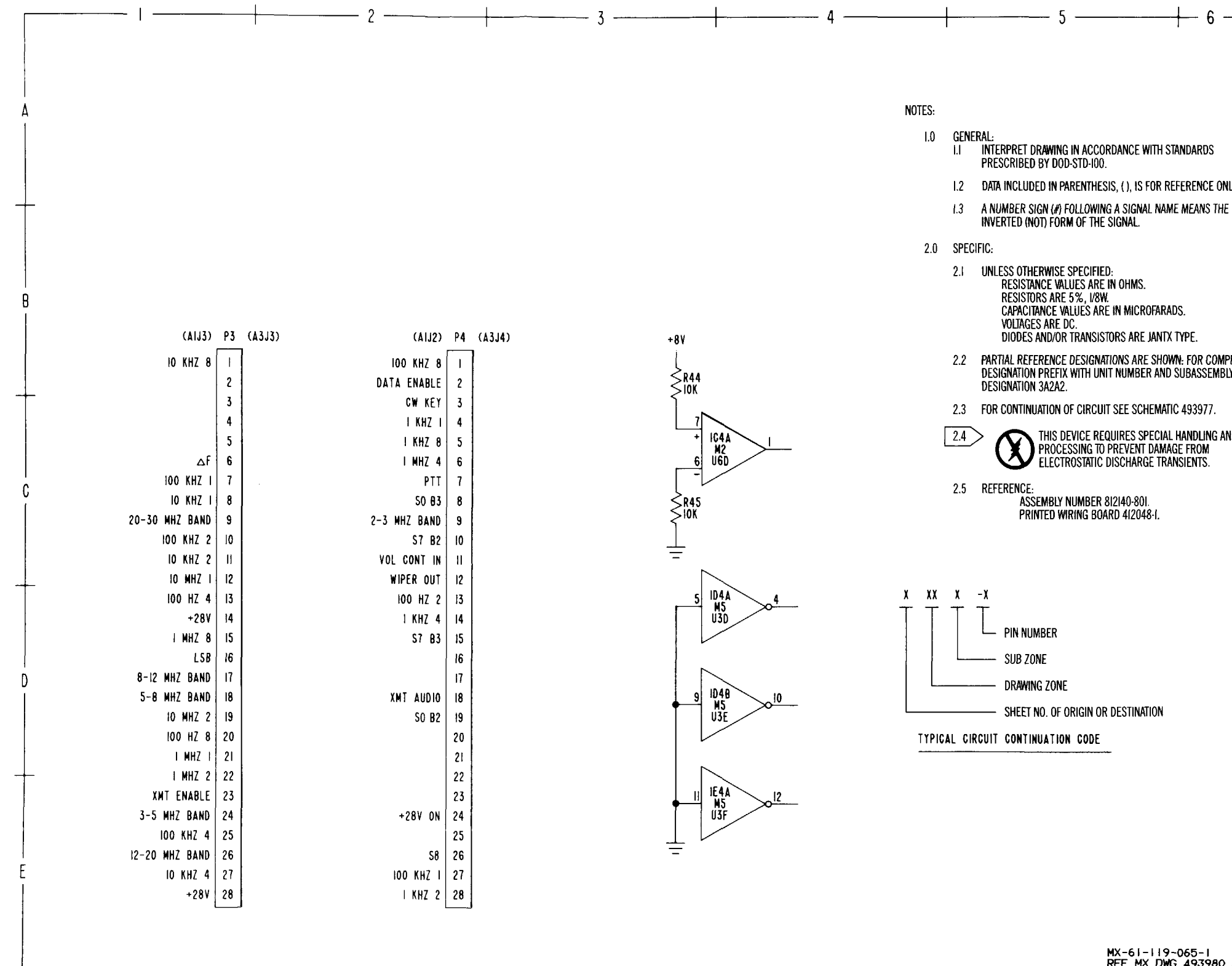

MX-61-119-065-1  
 REF MX DWG 493980 REV D



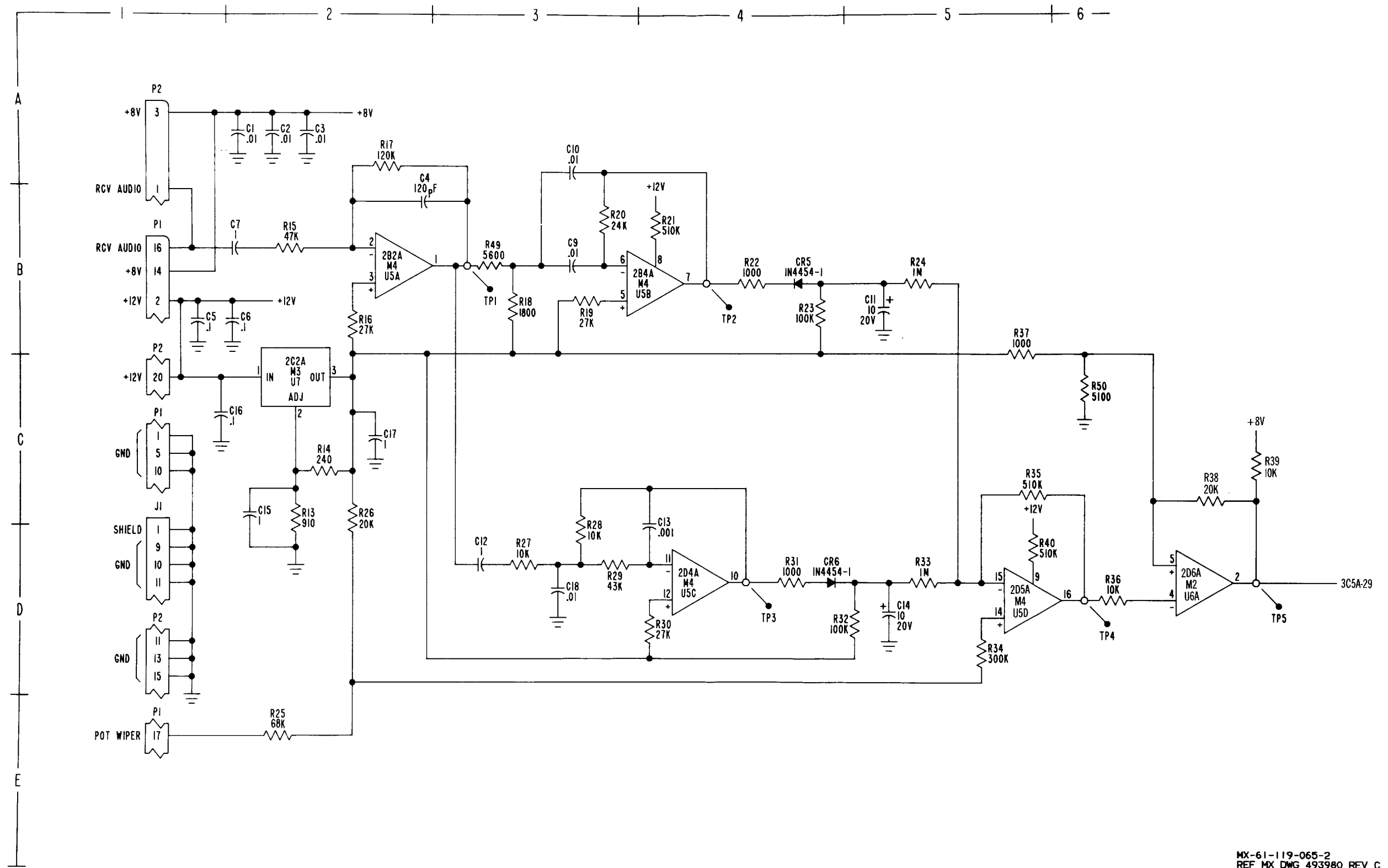

MX-61-119-065-2  
REF MX DWG 493980 REV C

FO-19. SDU Interface Schematic  
Diagram (Sheet 2 of 3)

FO-165/(FO-166 blank)



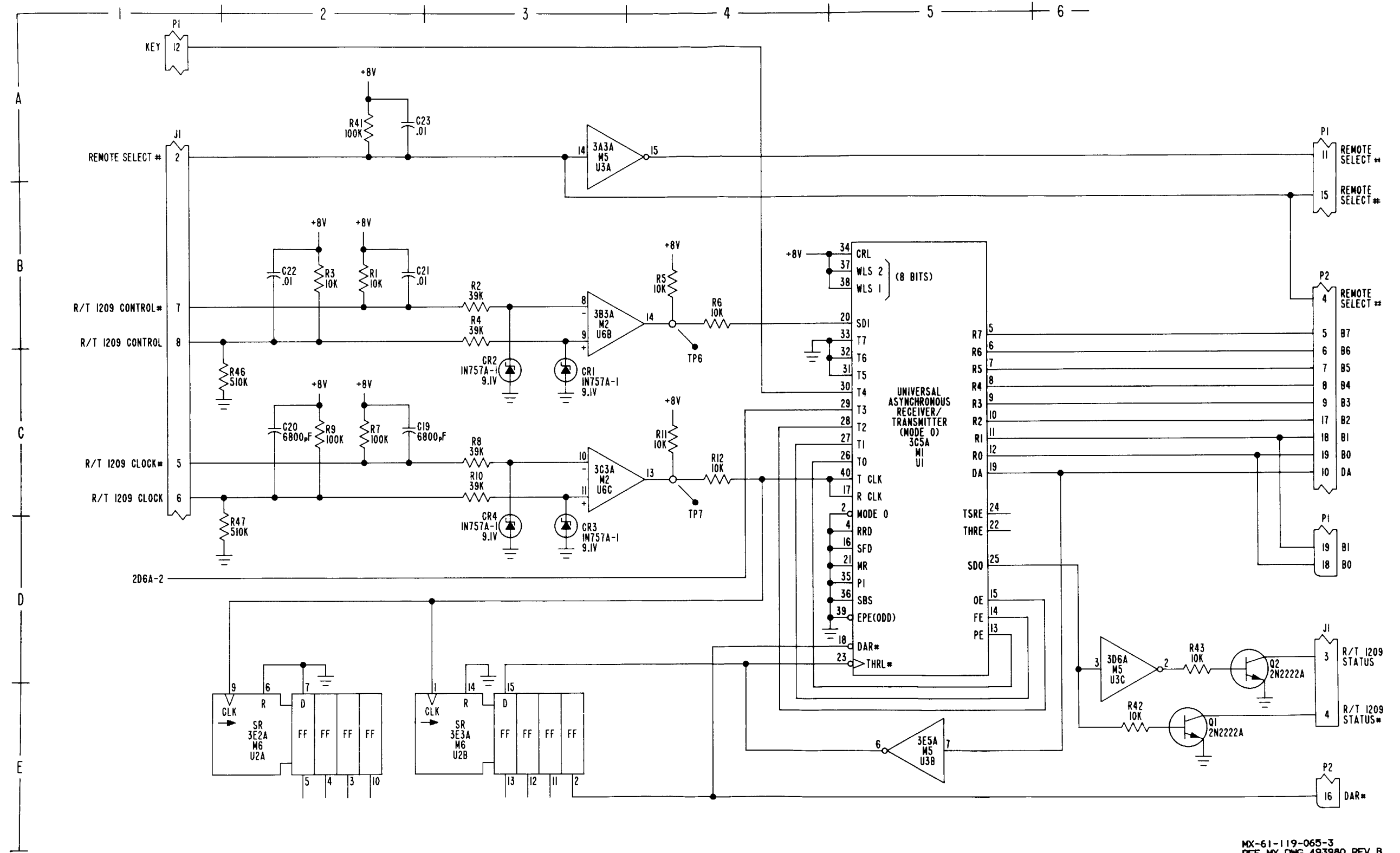

MX-61-119-065-3  
REF MX DWG 493980 REV B

FO-19. SDU Interface Schematic Diagram (Sheet 3 of 3)

FO-167/(FO-168 blank)





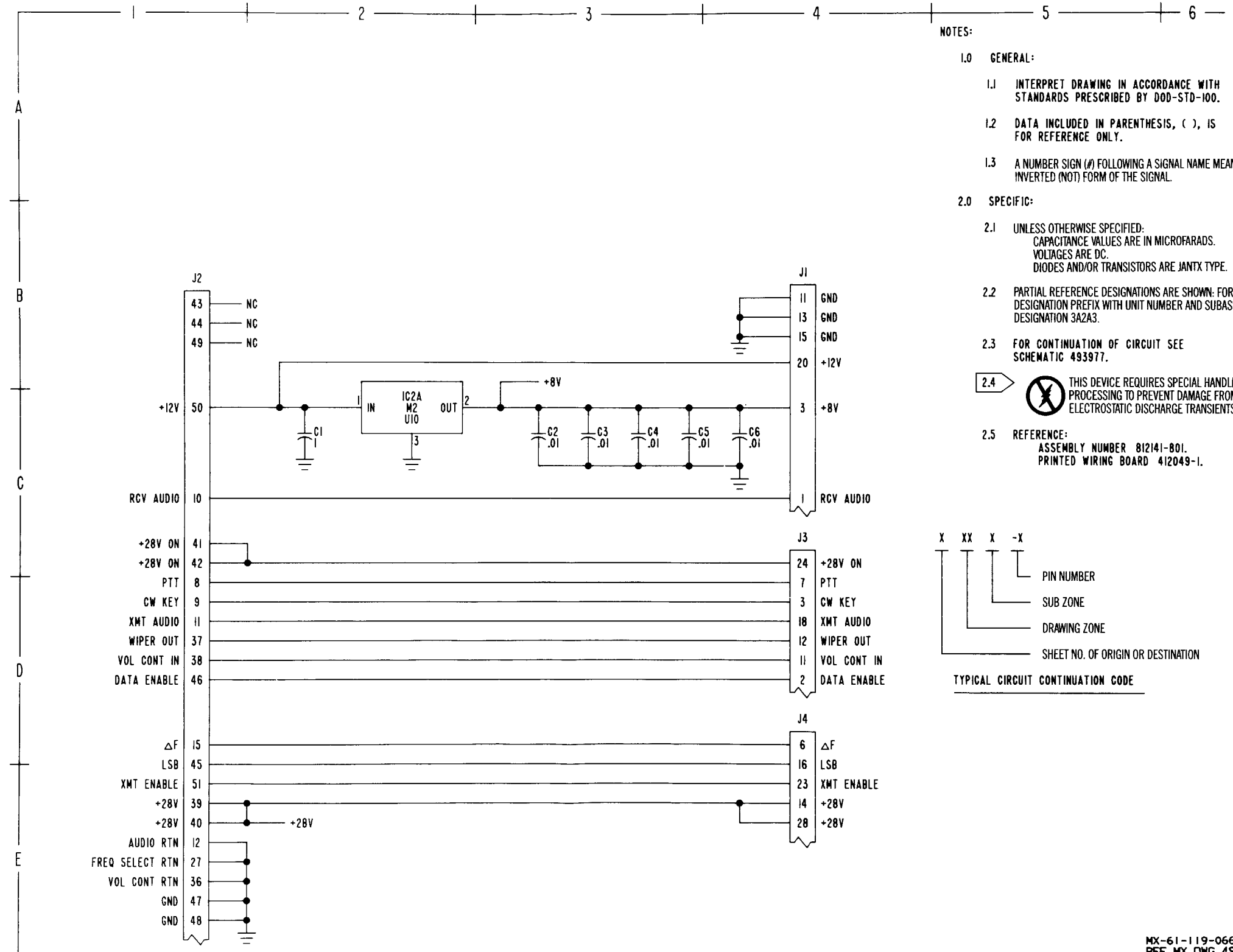

- NOTES:
- 1.0 GENERAL:
    - 1.1 INTERPRET DRAWING IN ACCORDANCE WITH STANDARDS PRESCRIBED BY DOD-STD-100.
    - 1.2 DATA INCLUDED IN PARENTHESIS, ( ), IS FOR REFERENCE ONLY.
    - 1.3 A NUMBER SIGN (#) FOLLOWING A SIGNAL NAME MEANS THE INVERTED (NOT) FORM OF THE SIGNAL.
  - 2.0 SPECIFIC:
    - 2.1 UNLESS OTHERWISE SPECIFIED: CAPACITANCE VALUES ARE IN MICROFARADS. VOLTAGES ARE DC. DIODES AND/OR TRANSISTORS ARE JANIX TYPE.
    - 2.2 PARTIAL REFERENCE DESIGNATIONS ARE SHOWN: FOR COMPLETE DESIGNATION PREFIX WITH UNIT NUMBER AND SUBASSEMBLY DESIGNATION 3A2A3.
    - 2.3 FOR CONTINUATION OF CIRCUIT SEE SCHEMATIC 493977.
    - 2.4  THIS DEVICE REQUIRES SPECIAL HANDLING AND PROCESSING TO PREVENT DAMAGE FROM ELECTROSTATIC DISCHARGE TRANSIENTS.
    - 2.5 REFERENCE: ASSEMBLY NUMBER 812141-801. PRINTED WIRING BOARD 412049-1.

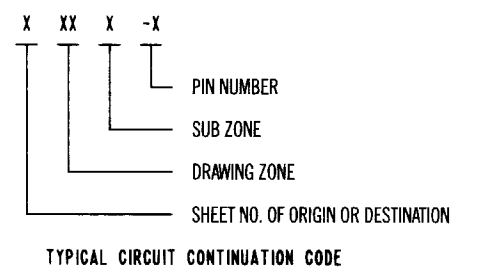

MX-61-119-066-1  
REF MX DWG 493981 REV B

FO-20. RT Interface Schematic  
Diagram (Sheet 1 of 3)

FO-169/(FO-170 blank)



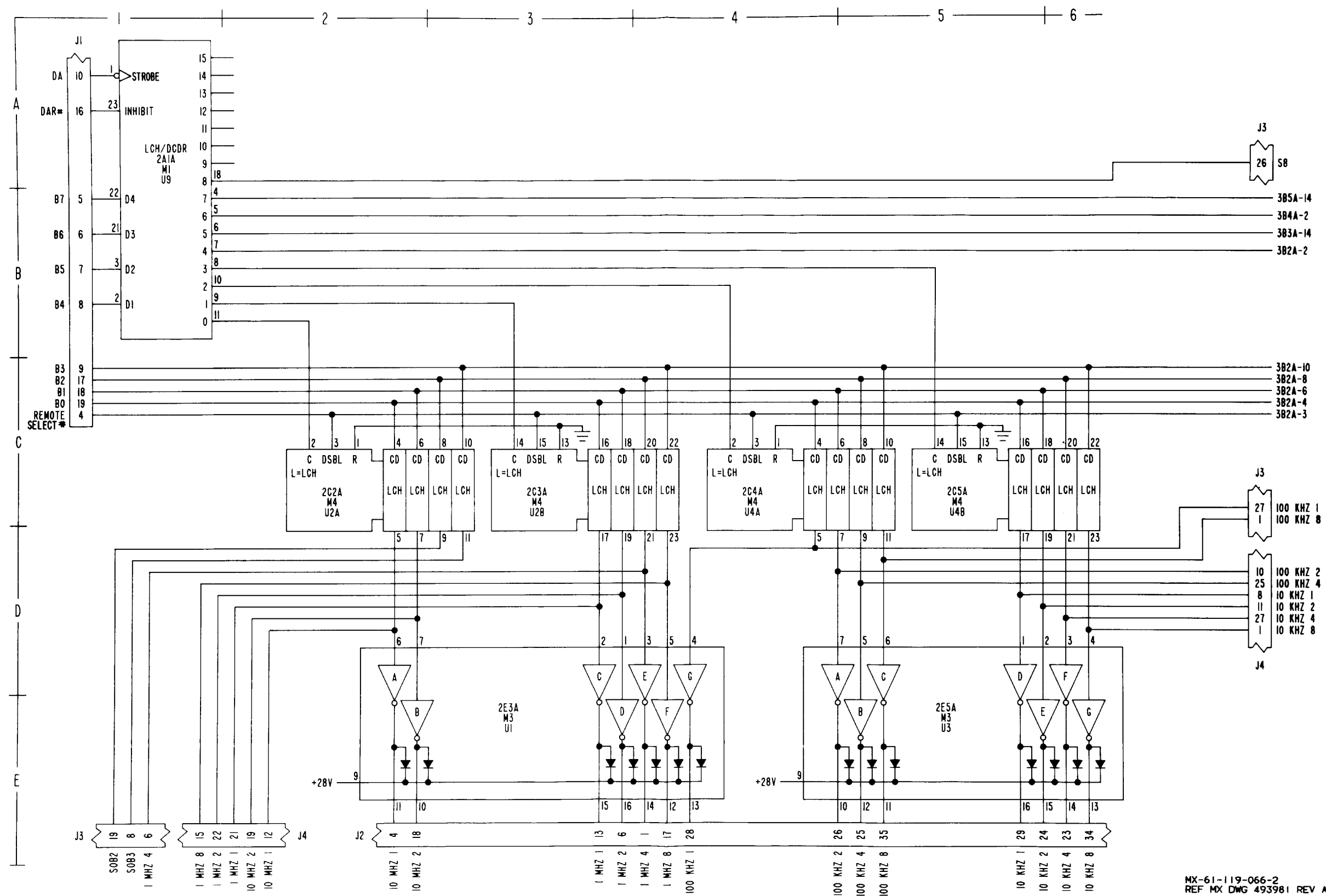

MX-61-119-066-2  
REF MX DWG 493981 REV A

FO-20. RT Interface Schematic  
Diagram (Sheet 2 of 3)

FO-171/(FO-172 blank)



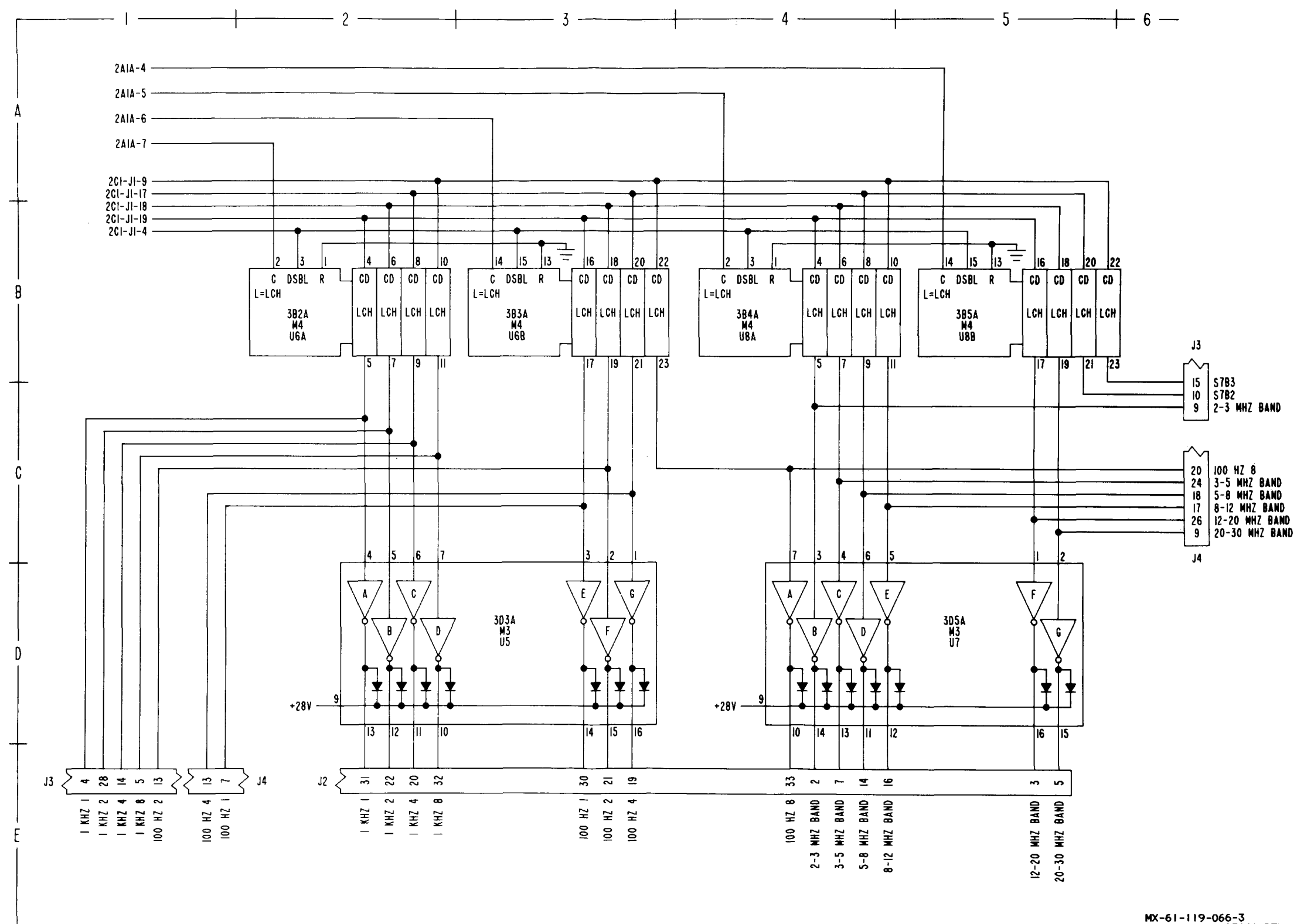

MX-61-119-066-3  
REF MX DWG 493981 REV -

FO-20. RT Interface Schematic  
Diagram (Sheet 3 of 3)

FO-173/(FO-174 blank)

